

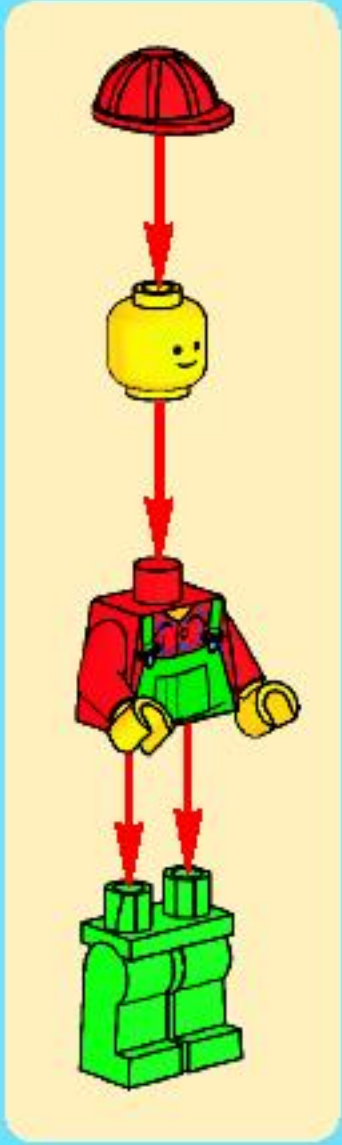

# GRAND EMPORIUM LE GRAND MAGASIN

10211

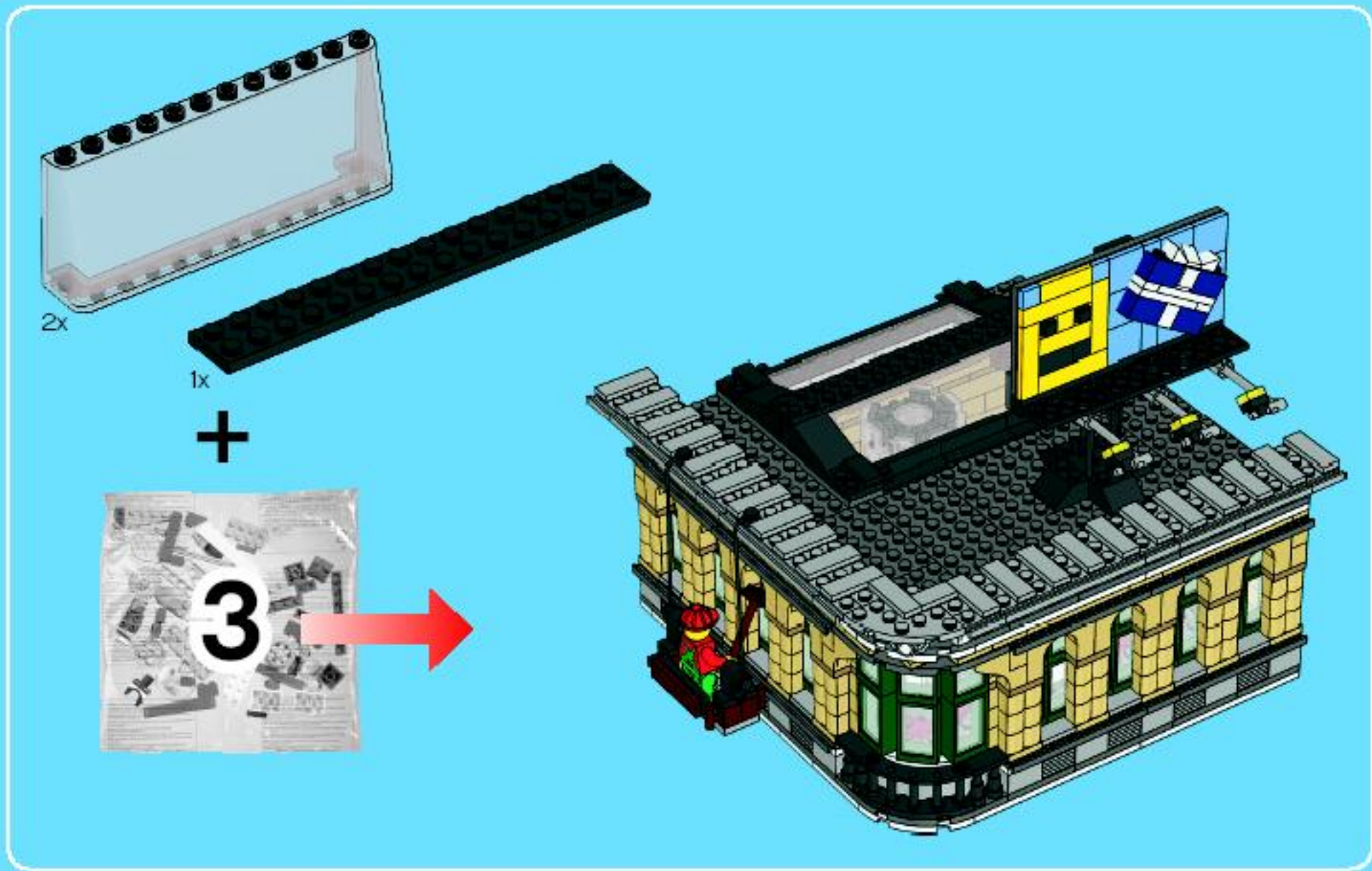



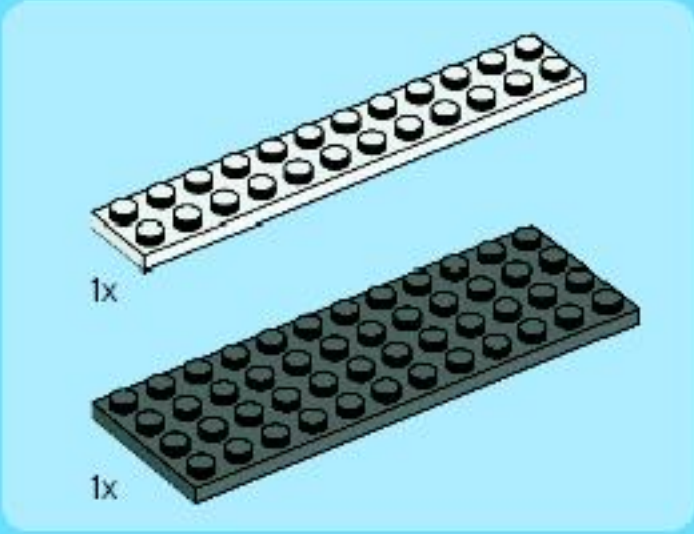
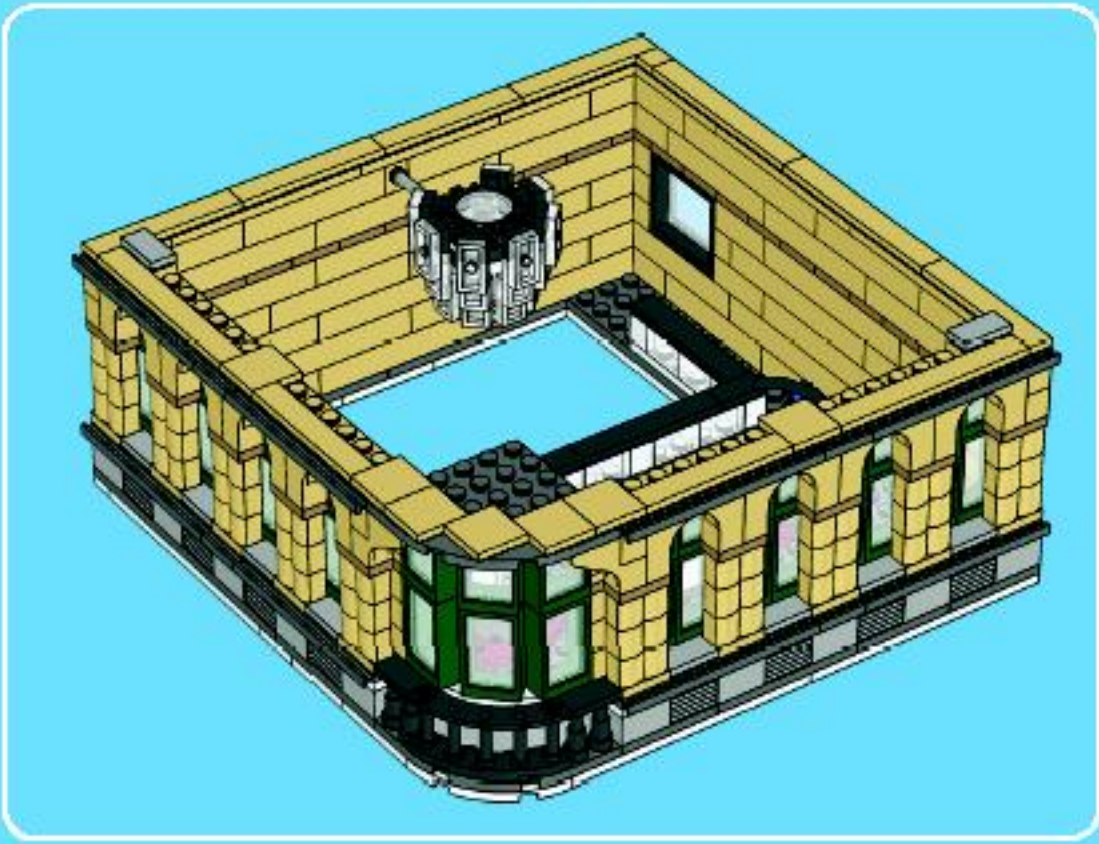

1

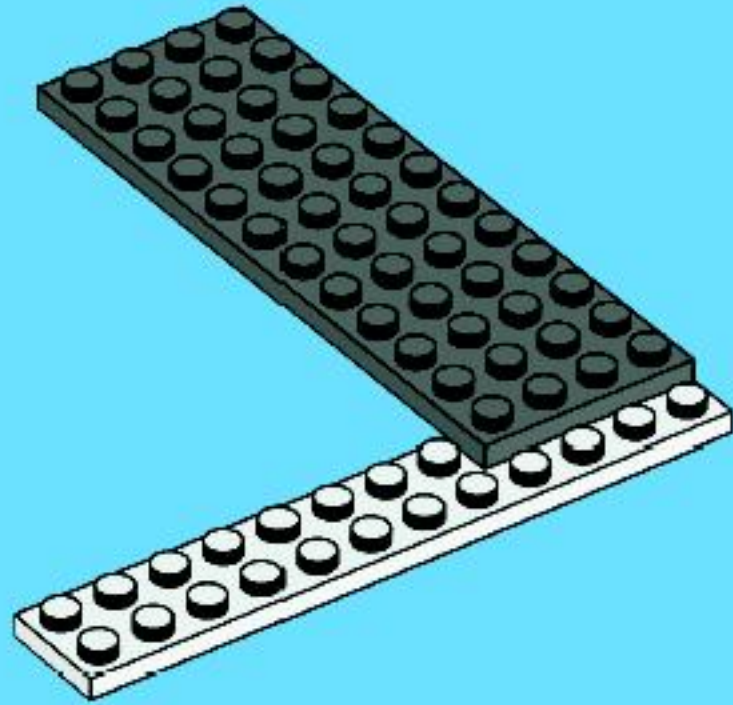

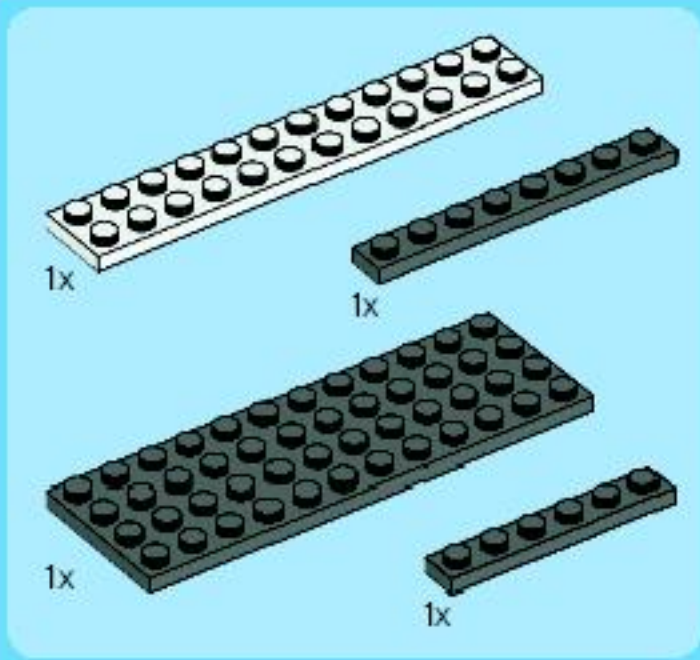

2

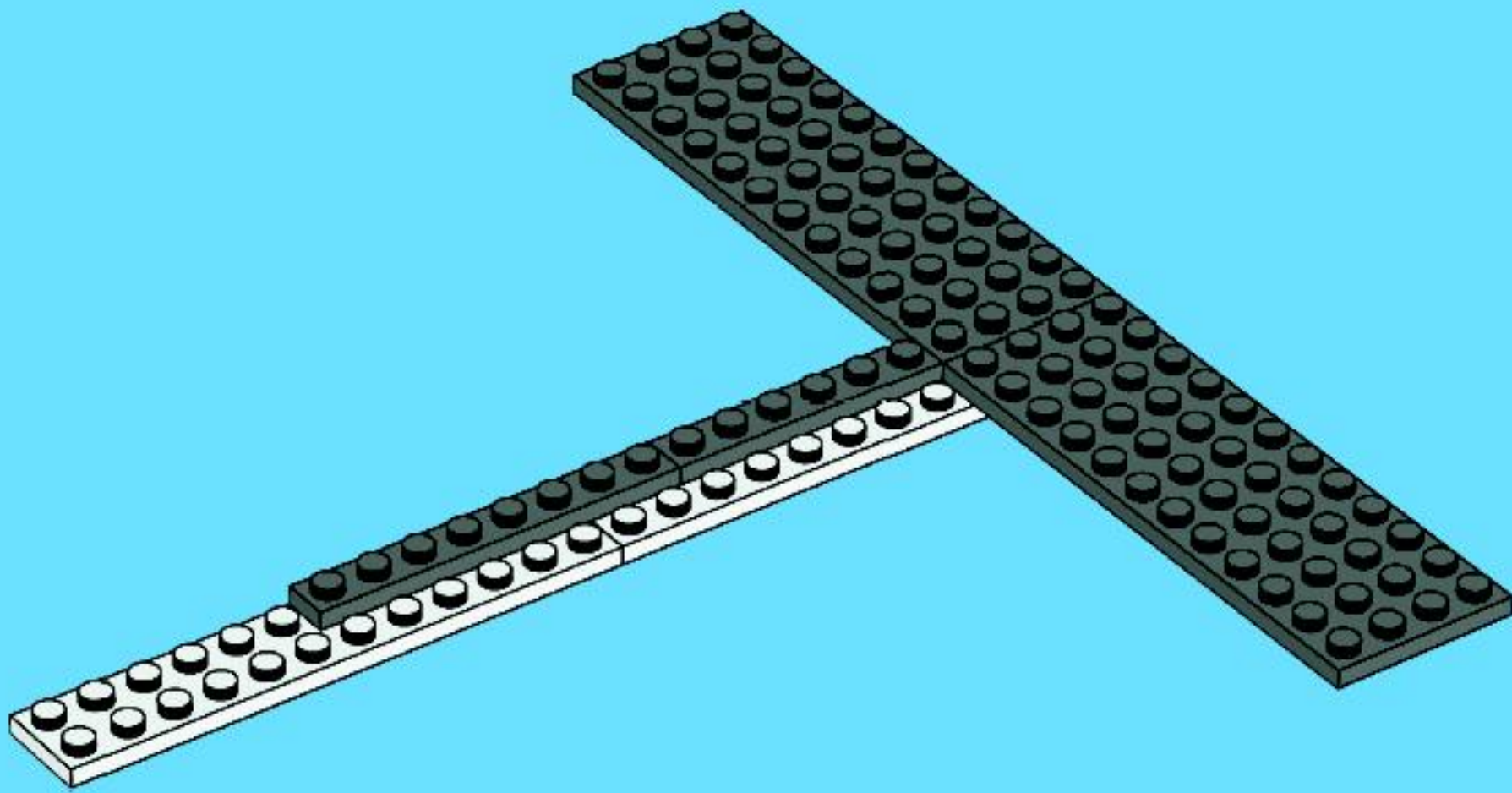

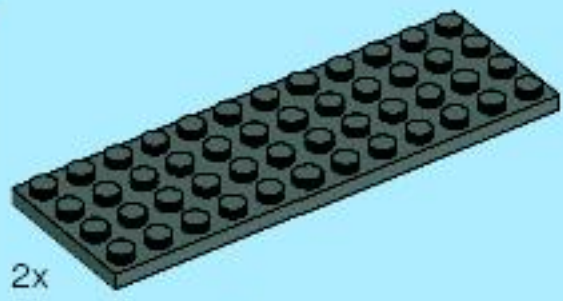

2x



1x

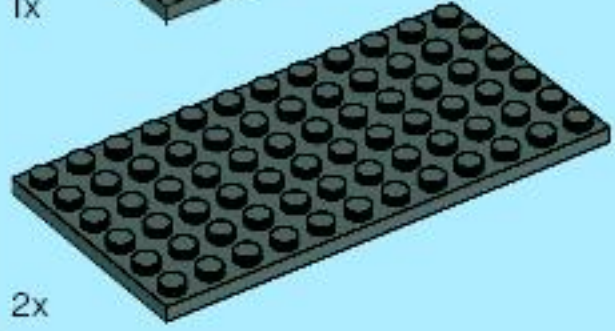

2x

# 3

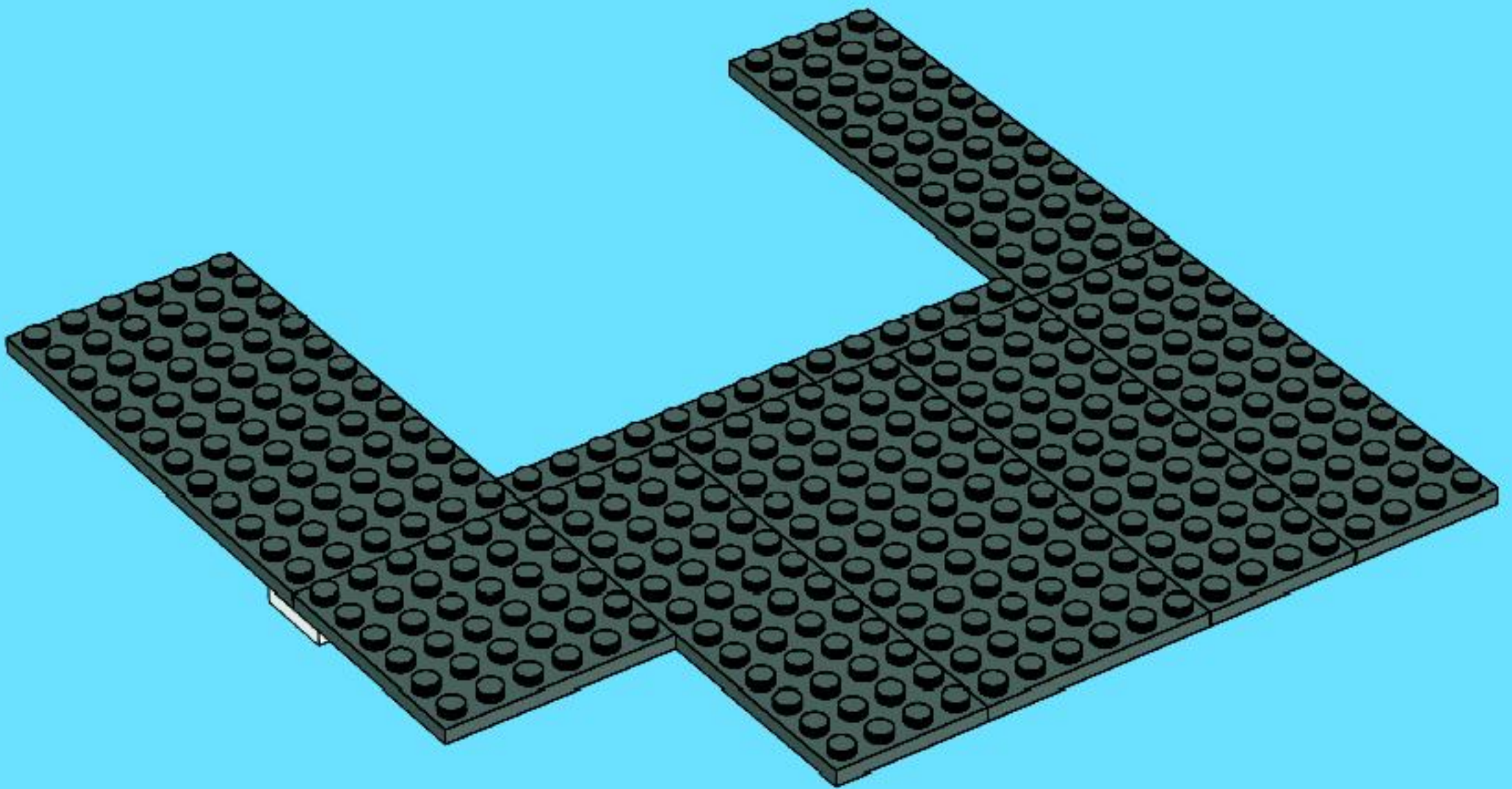

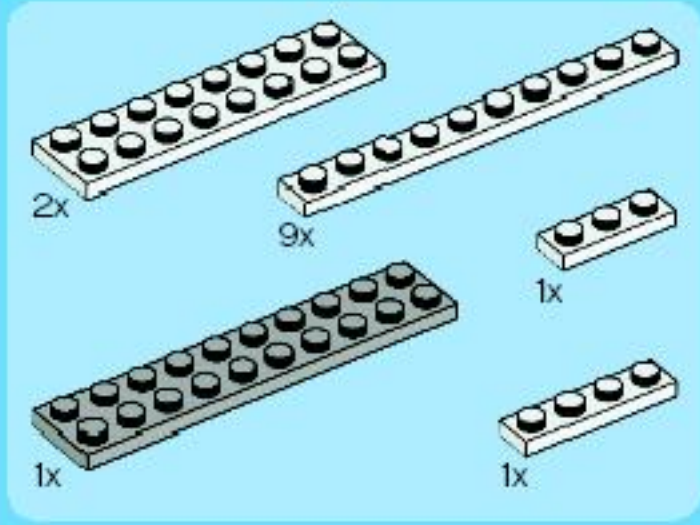

4

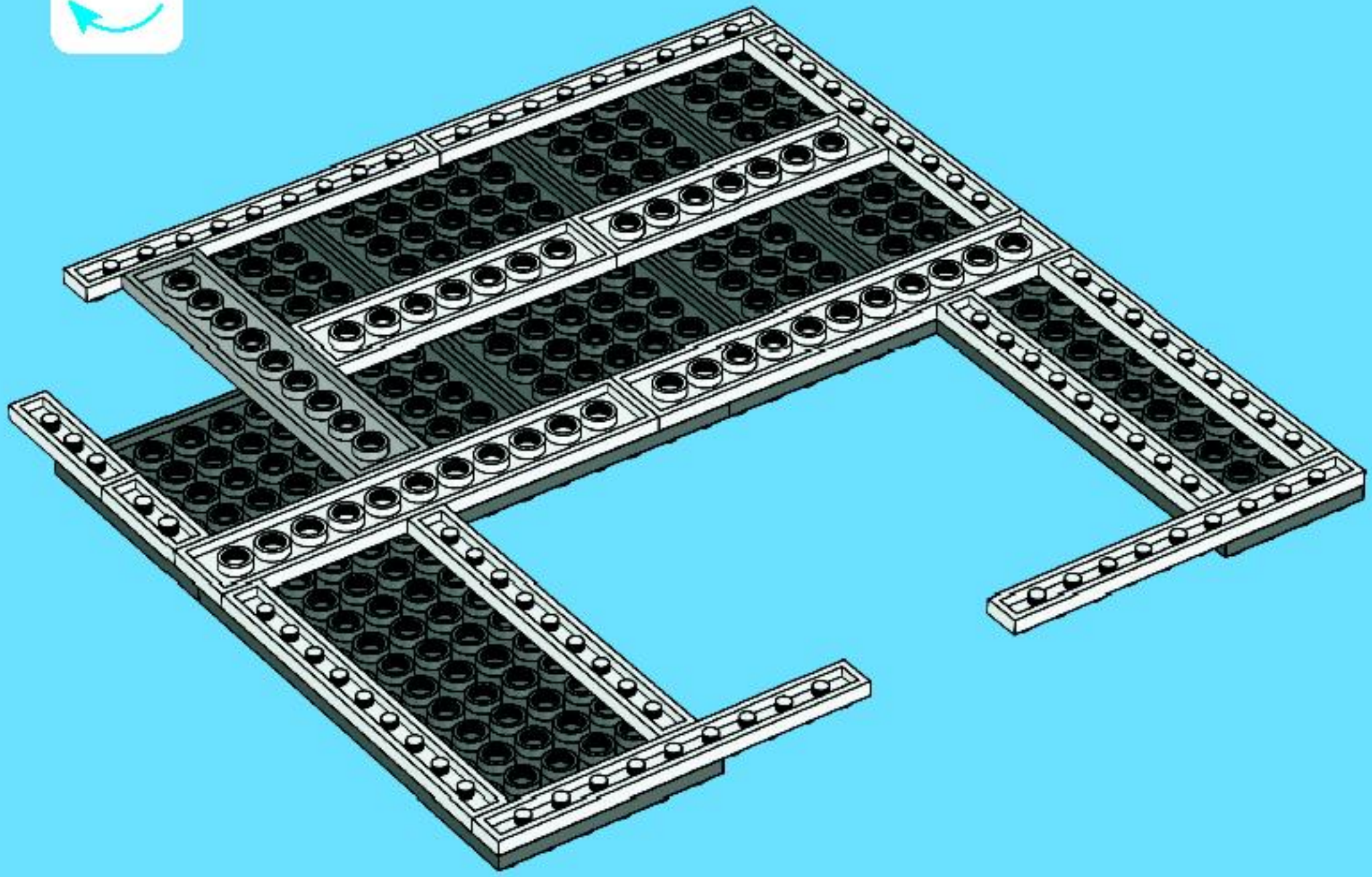

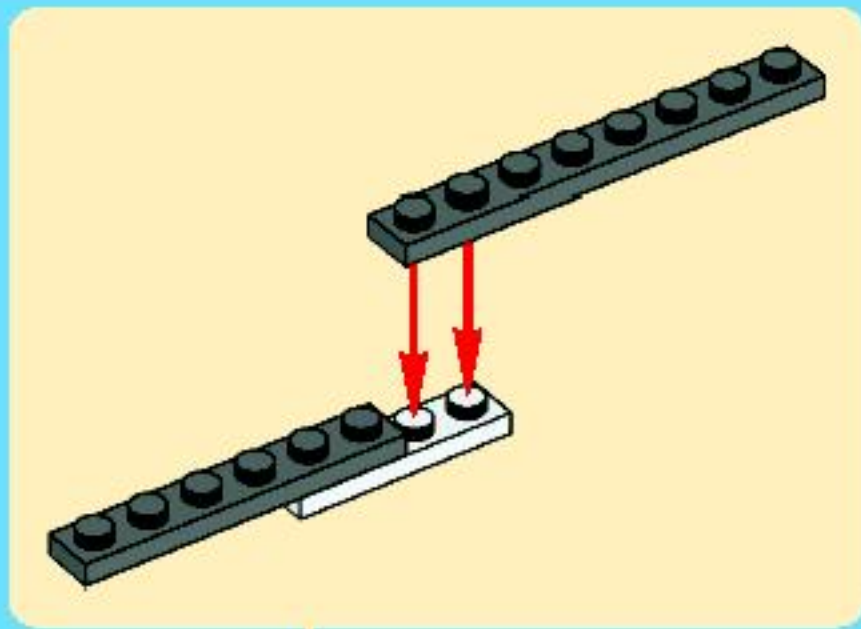
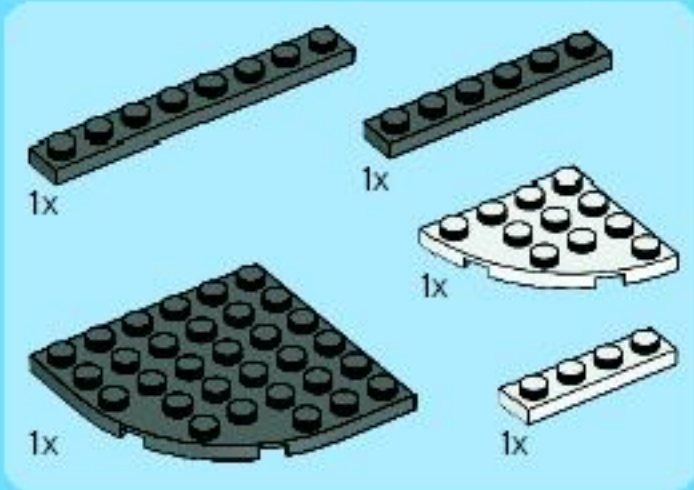

5

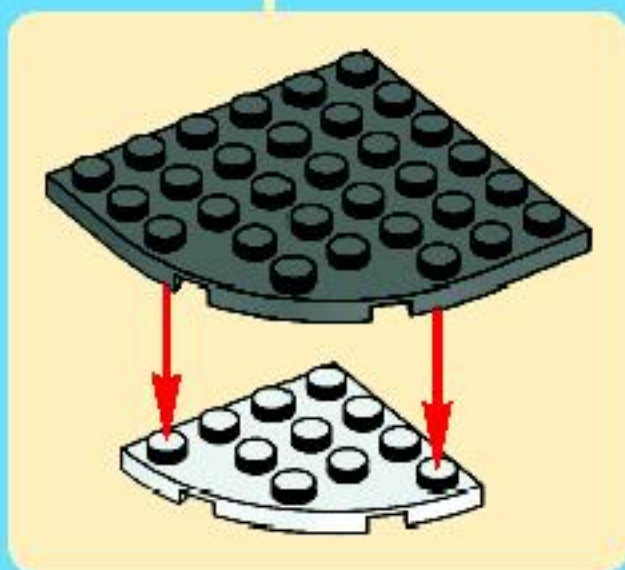
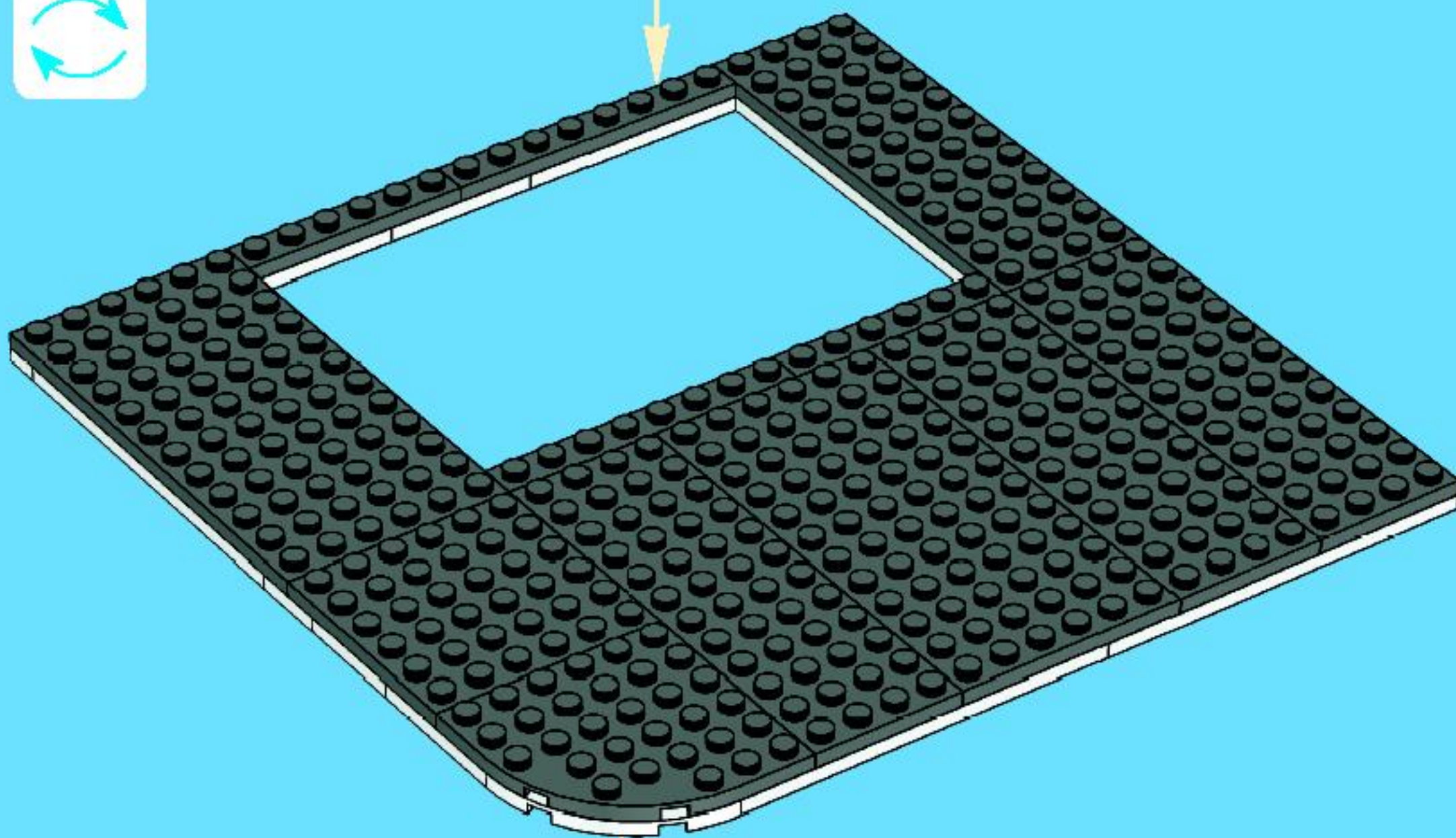

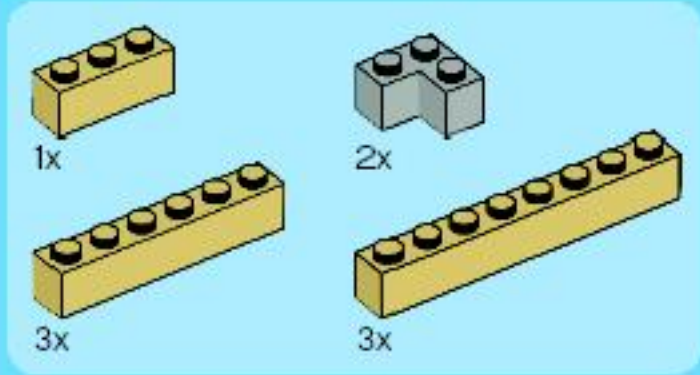

6

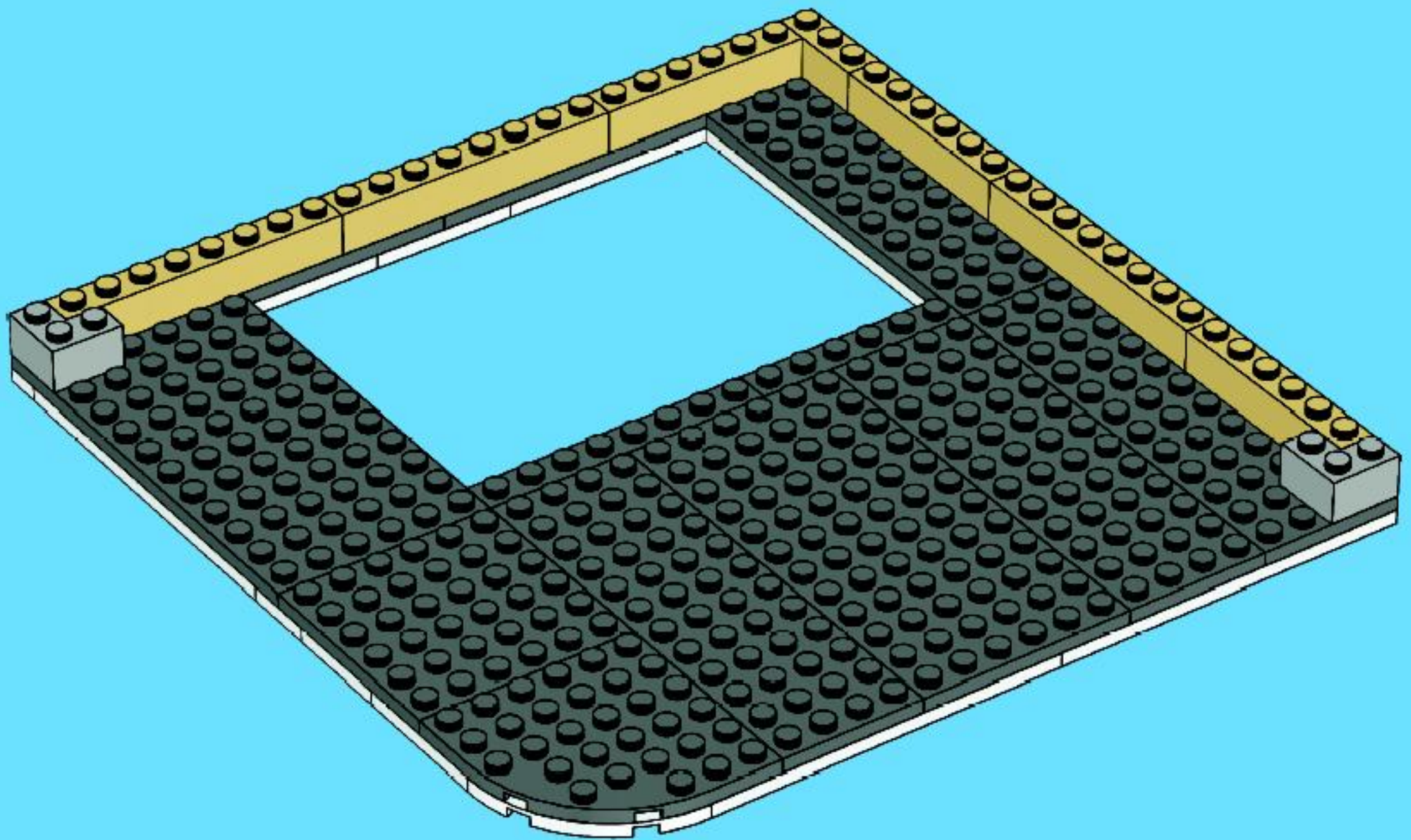



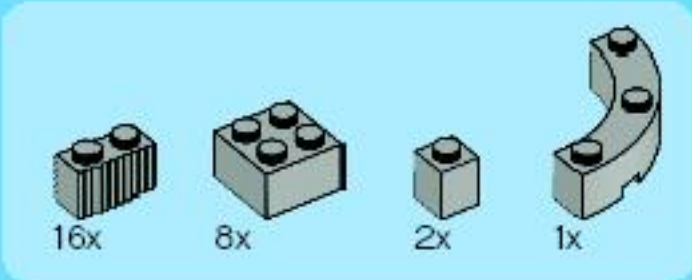

7

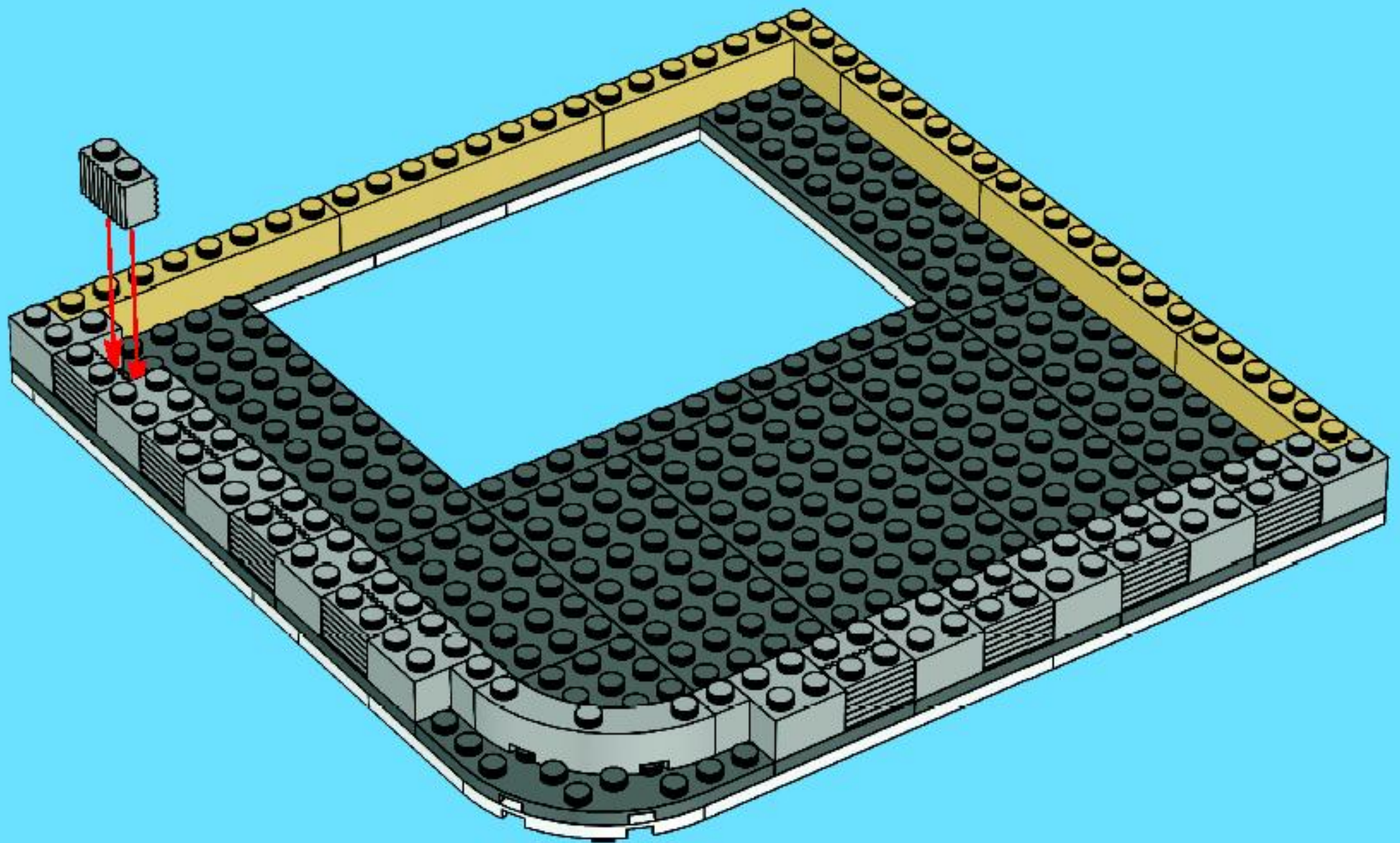

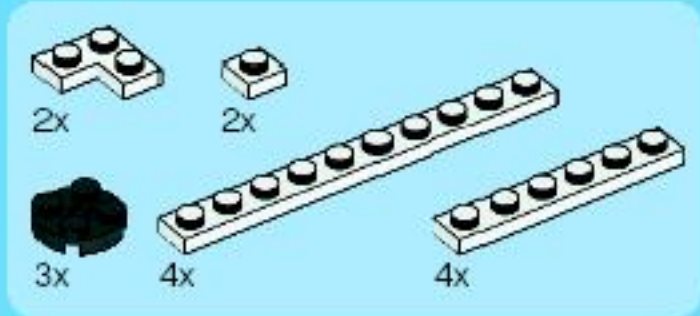

8

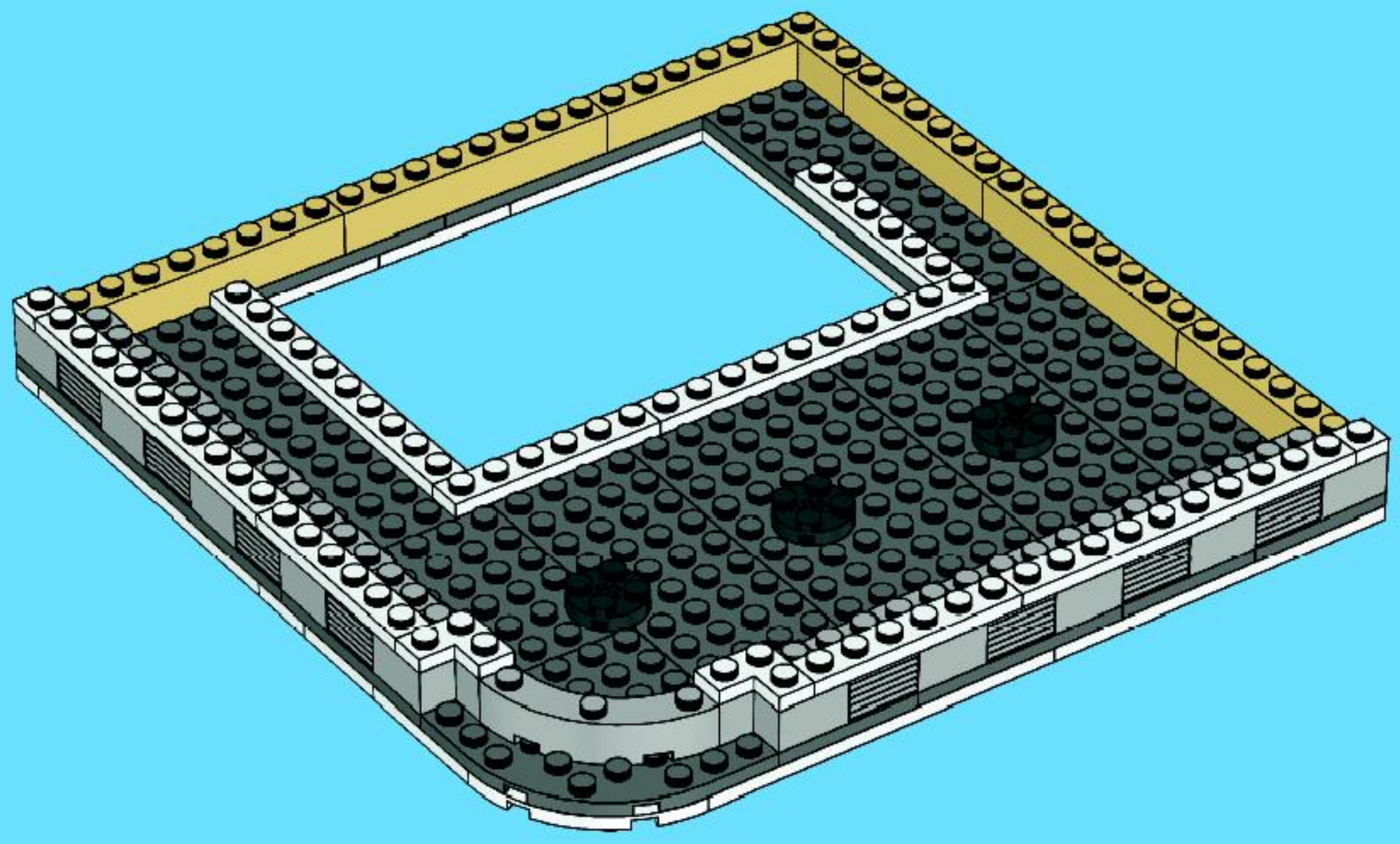

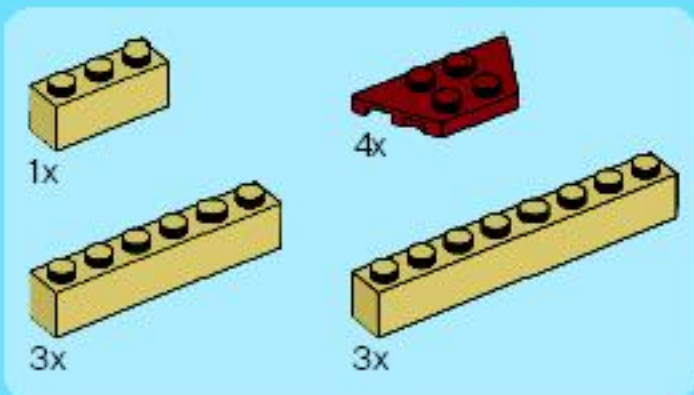

9

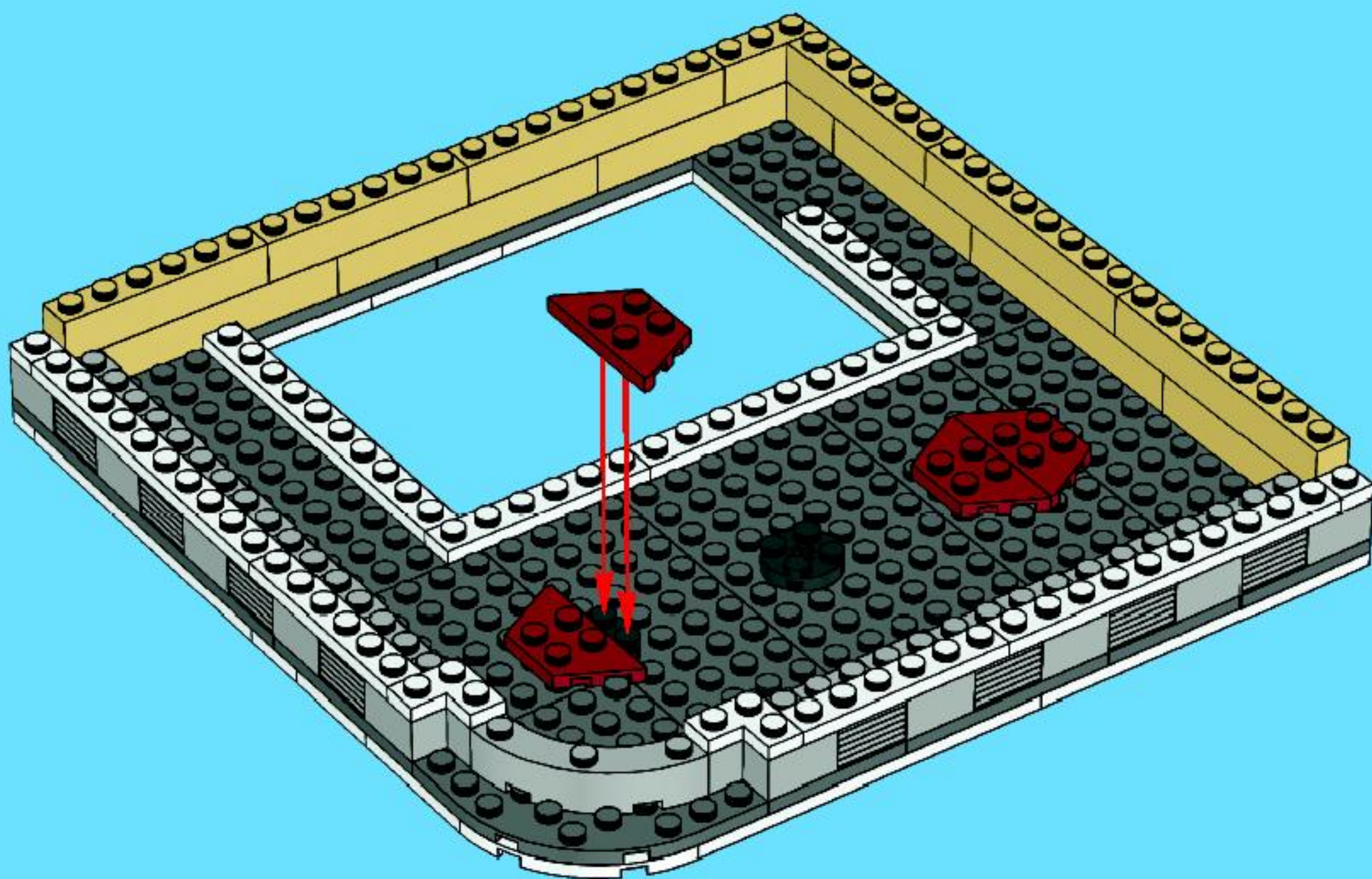

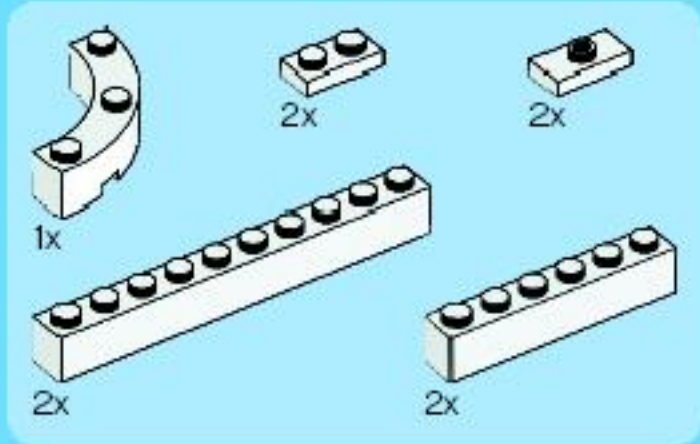

10

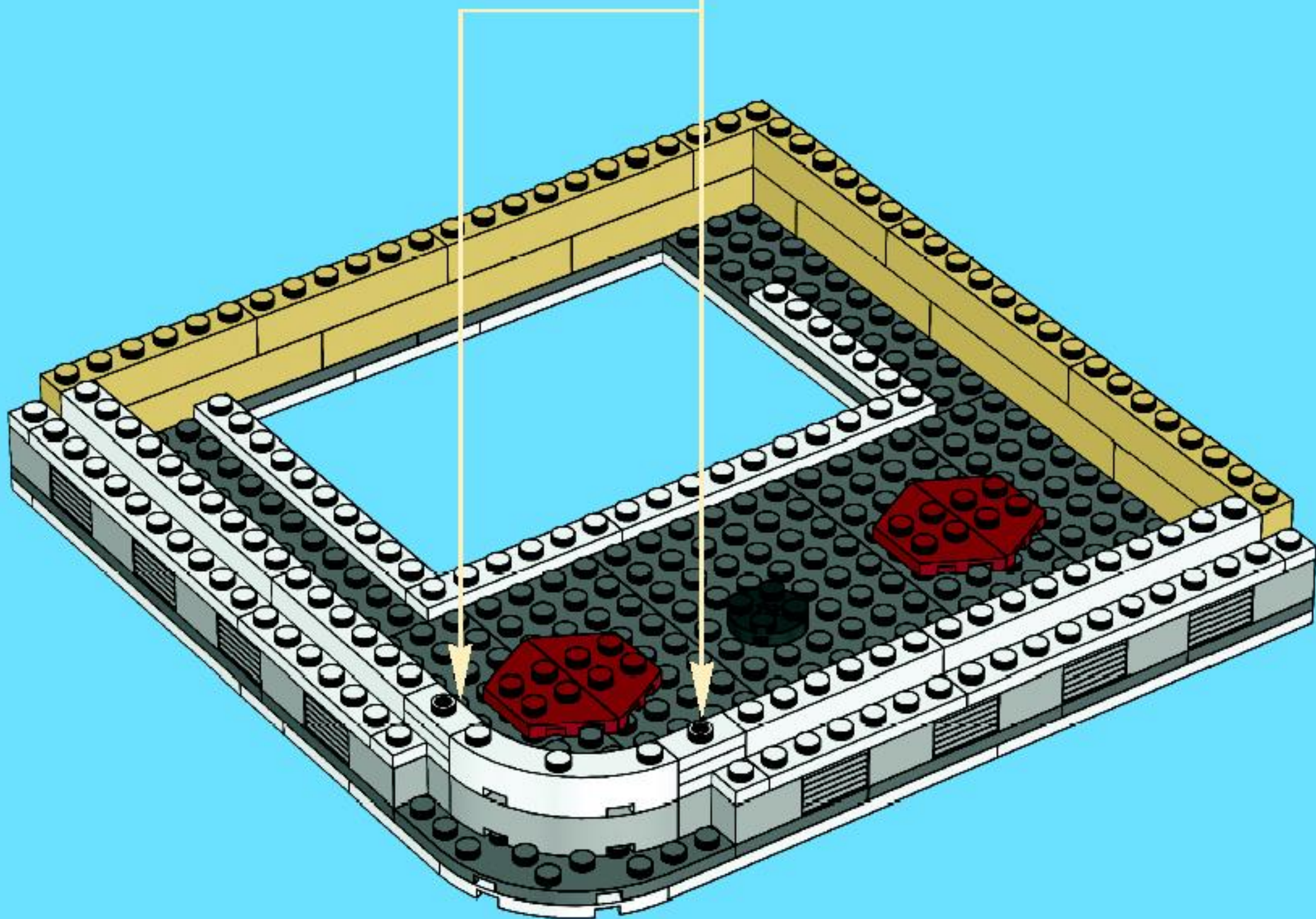
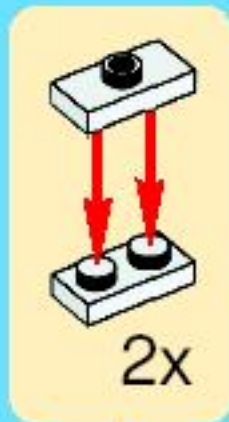



2x



4x



12x



2x

# 11

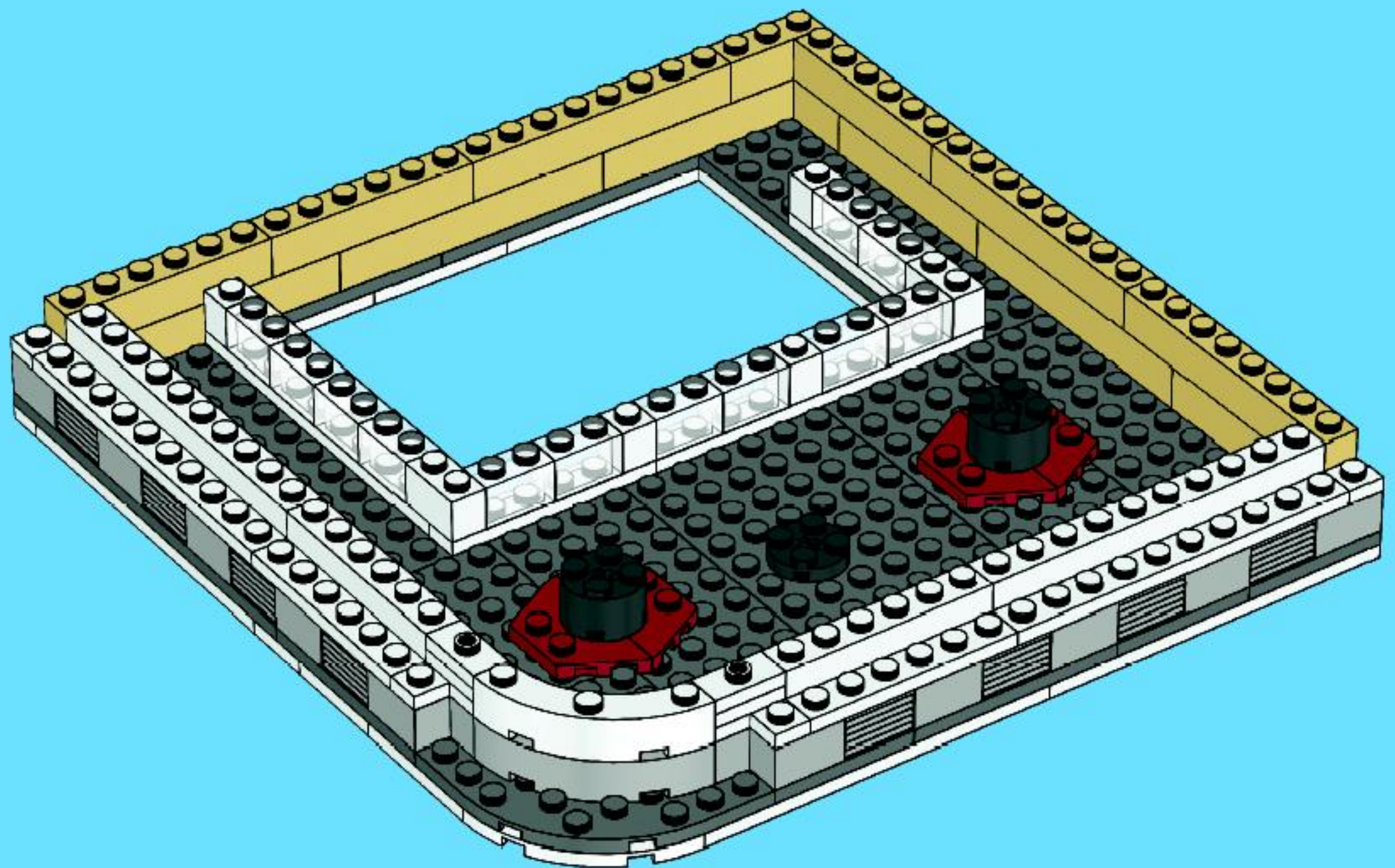

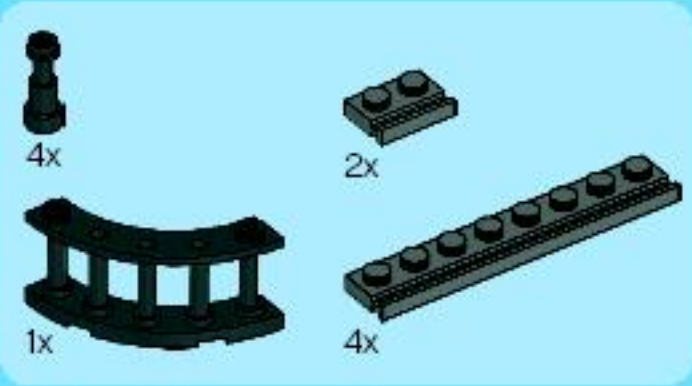

12

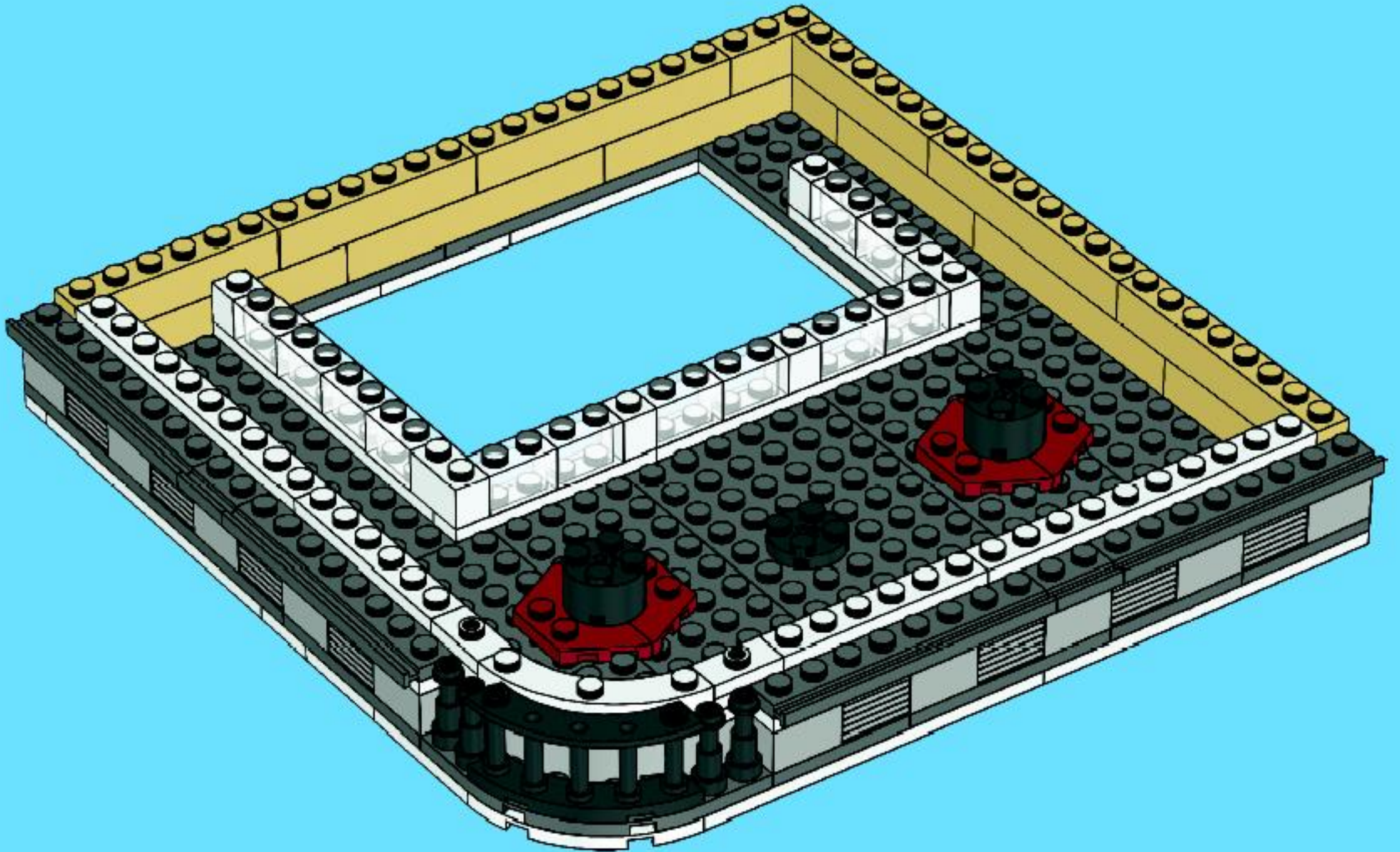

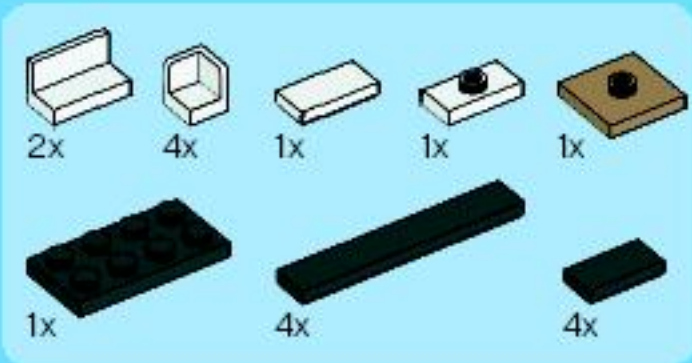

13

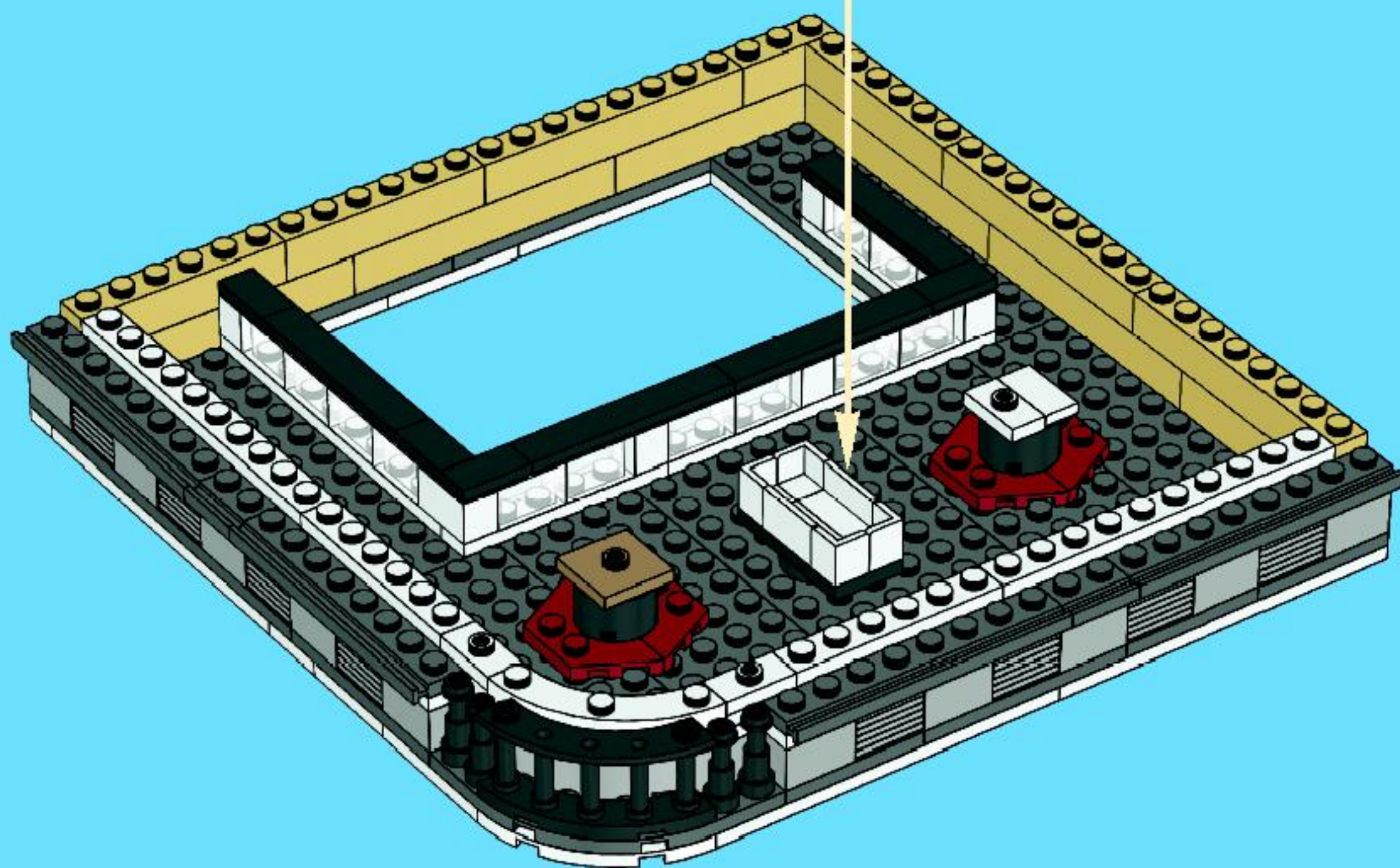
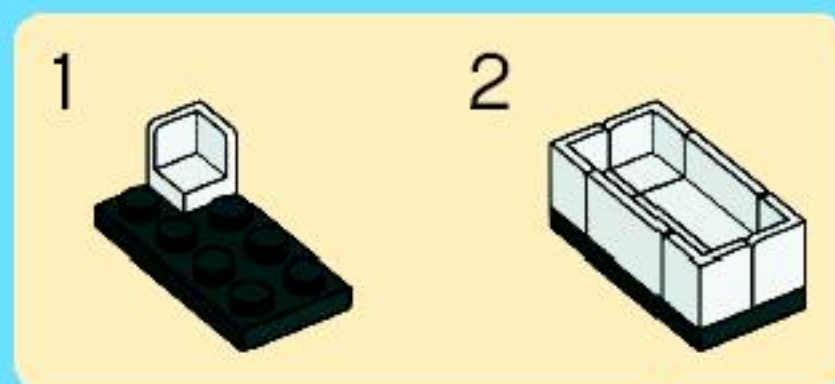



2x



10x



8x

# 14

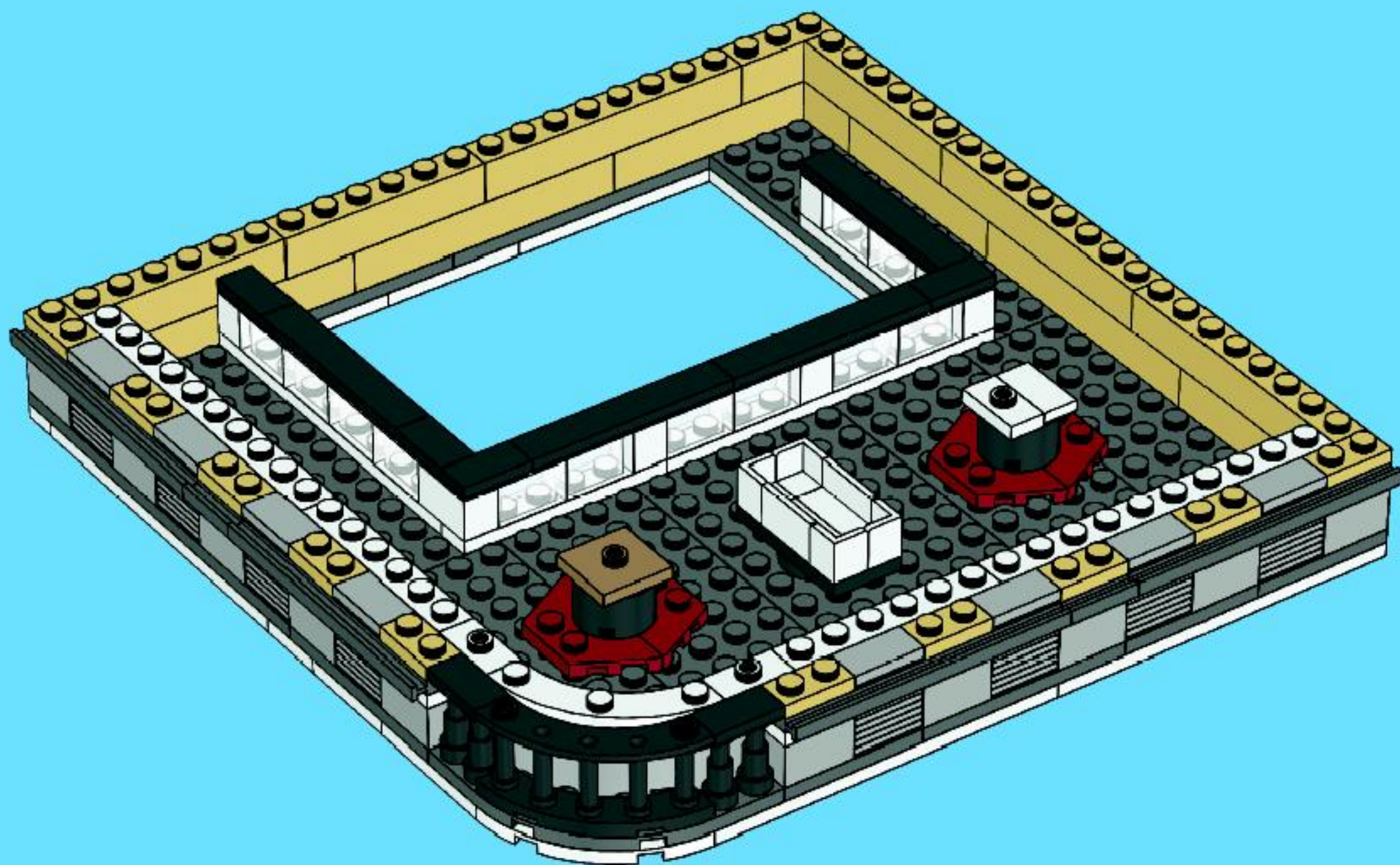



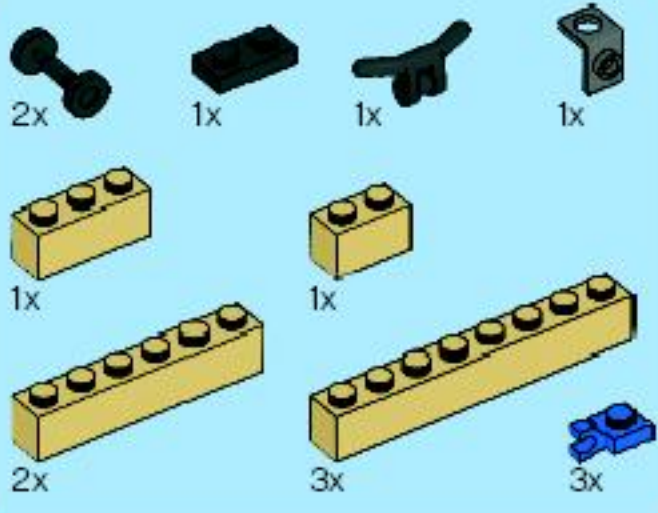

15

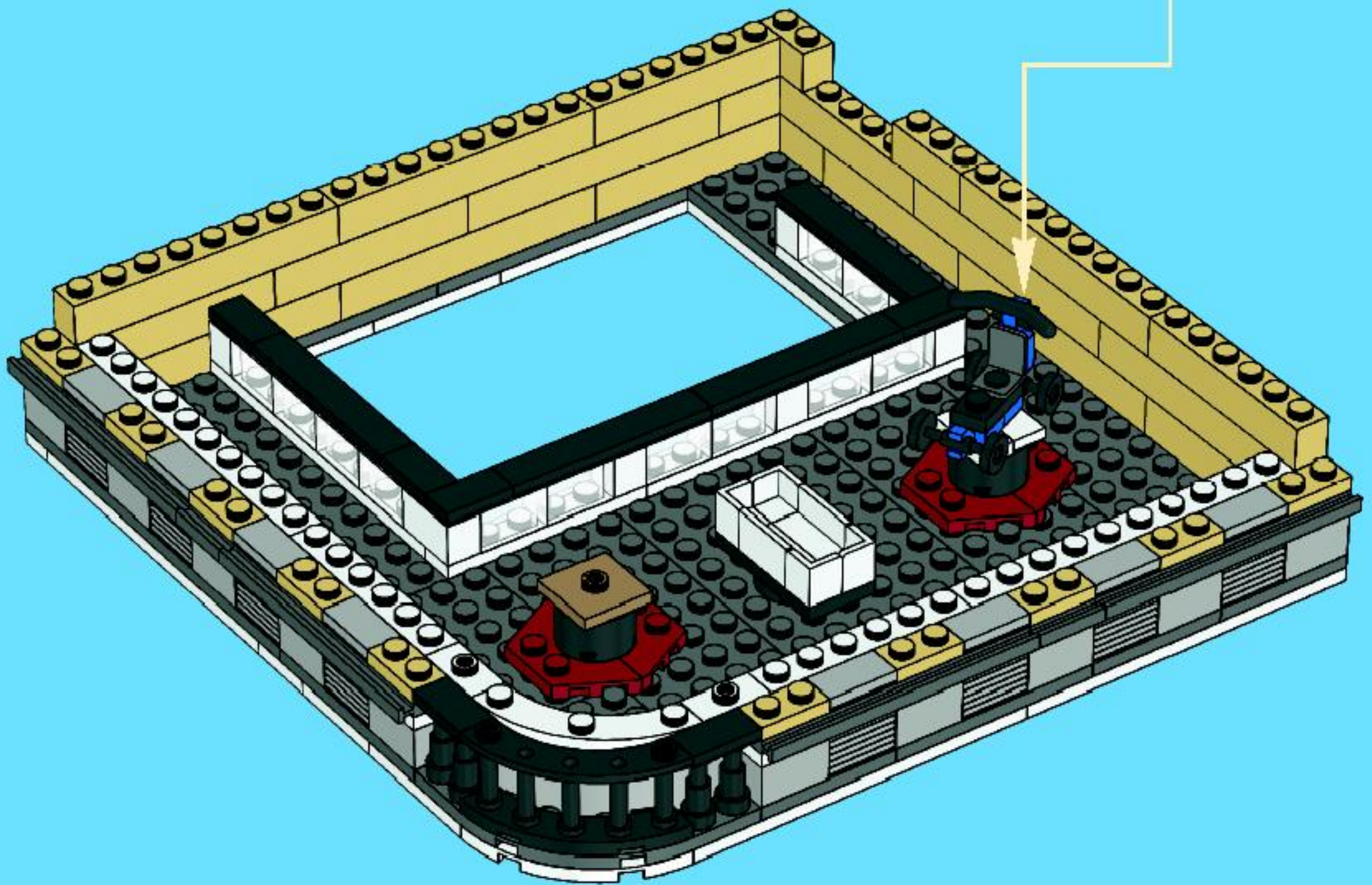
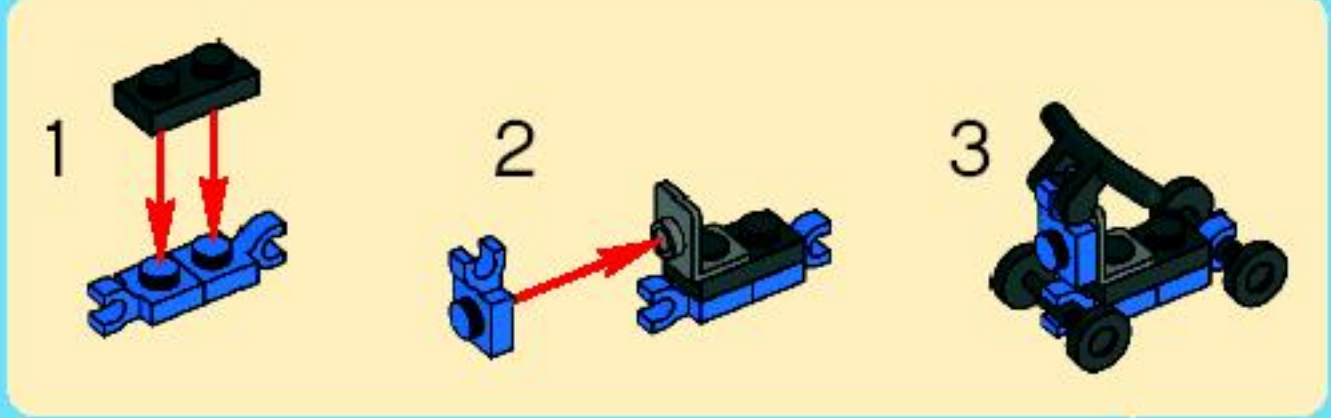

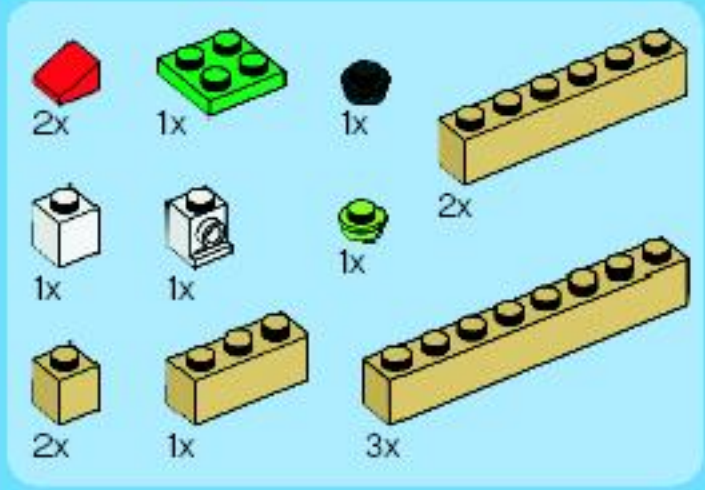

16

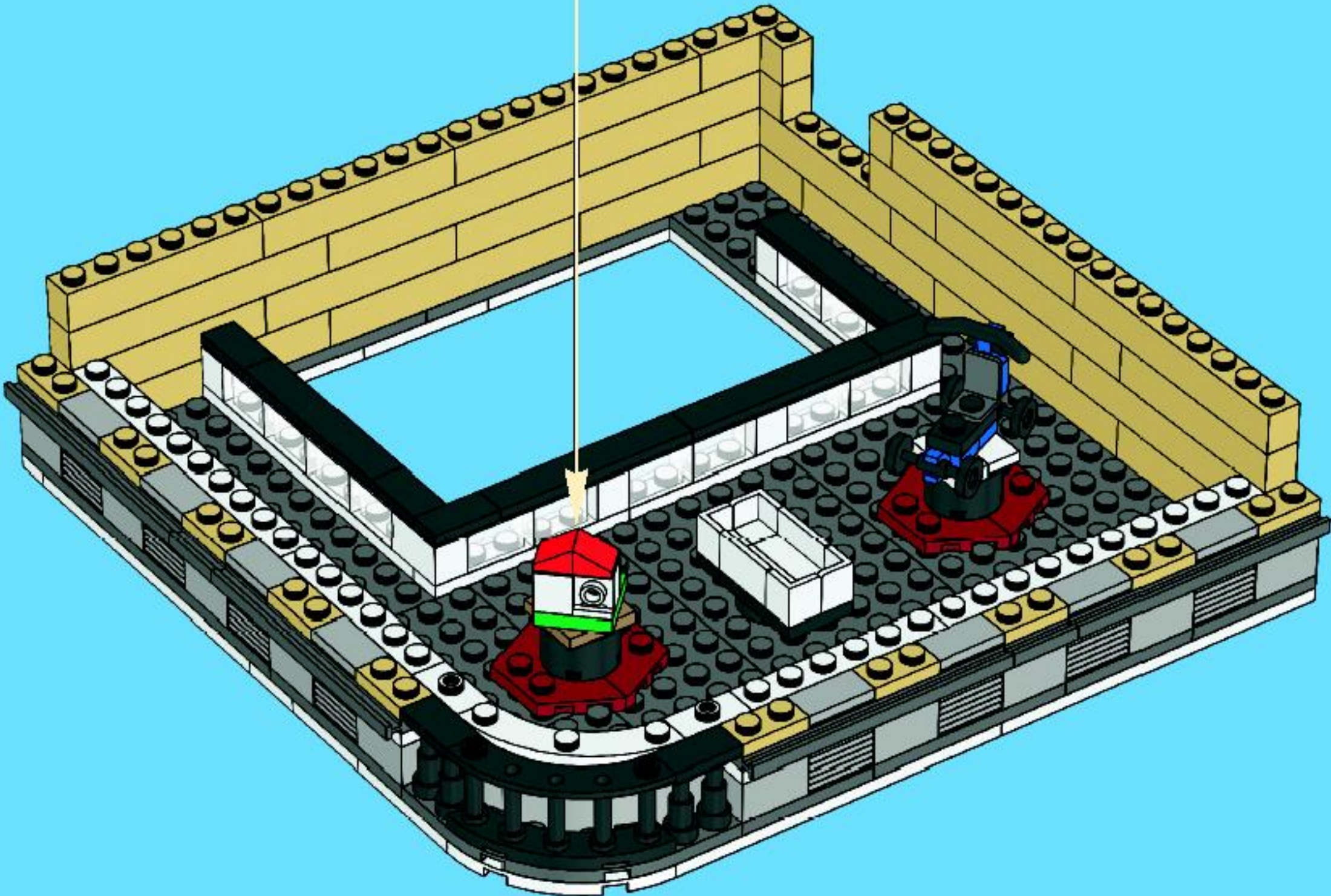
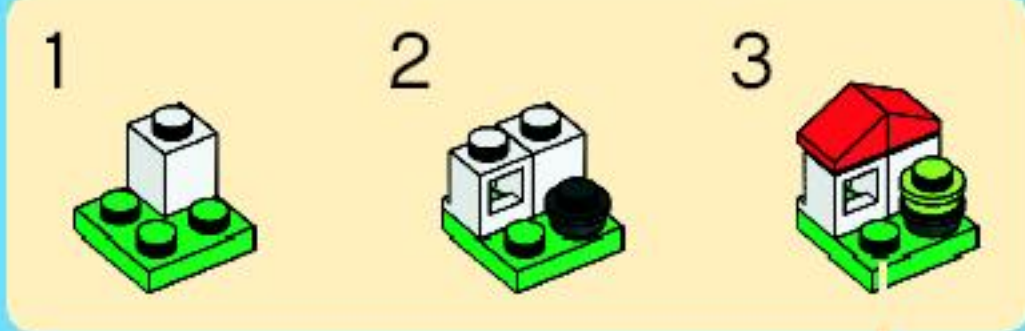

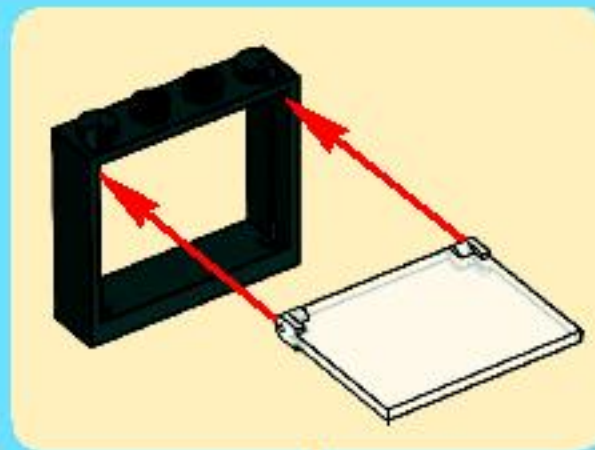
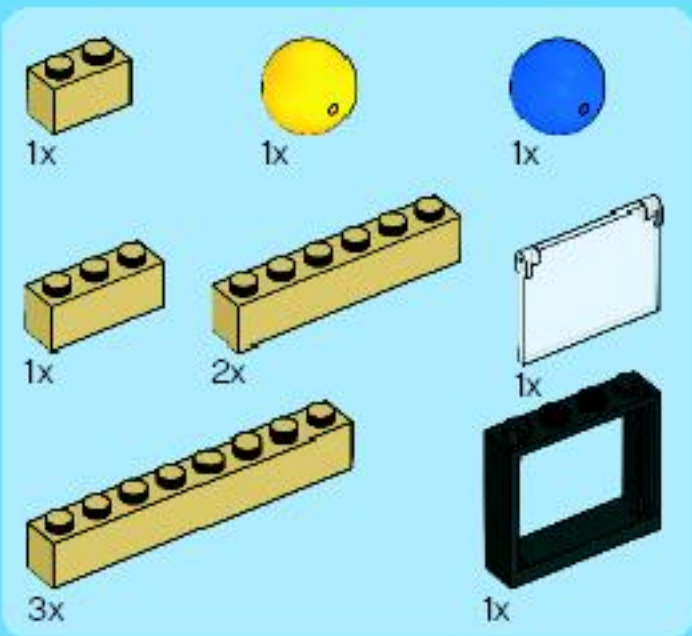

17

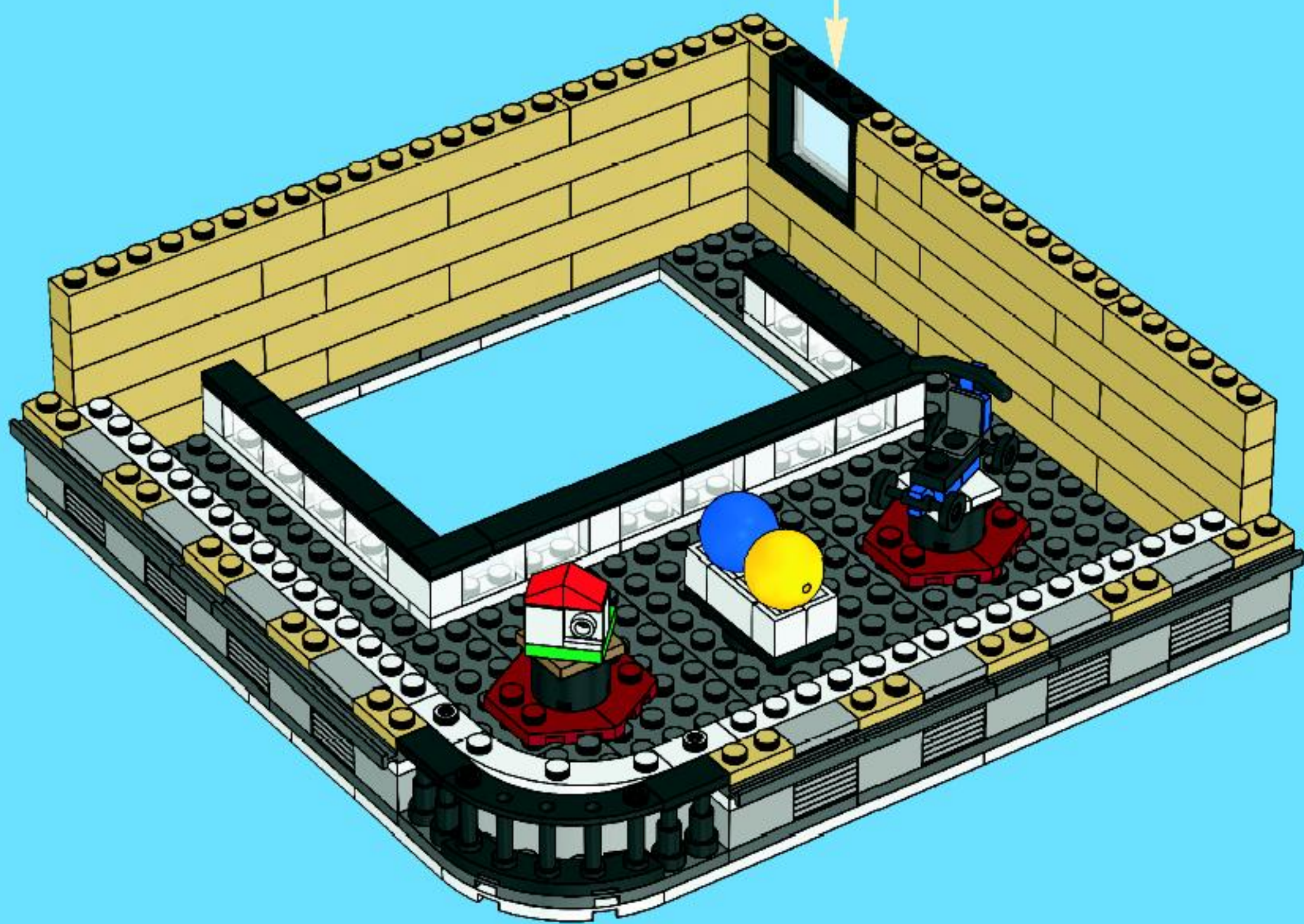



30x

# 18

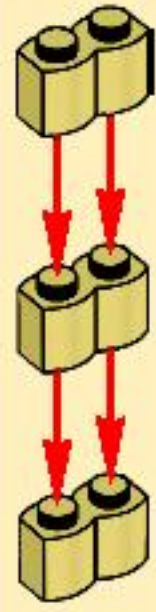

10x

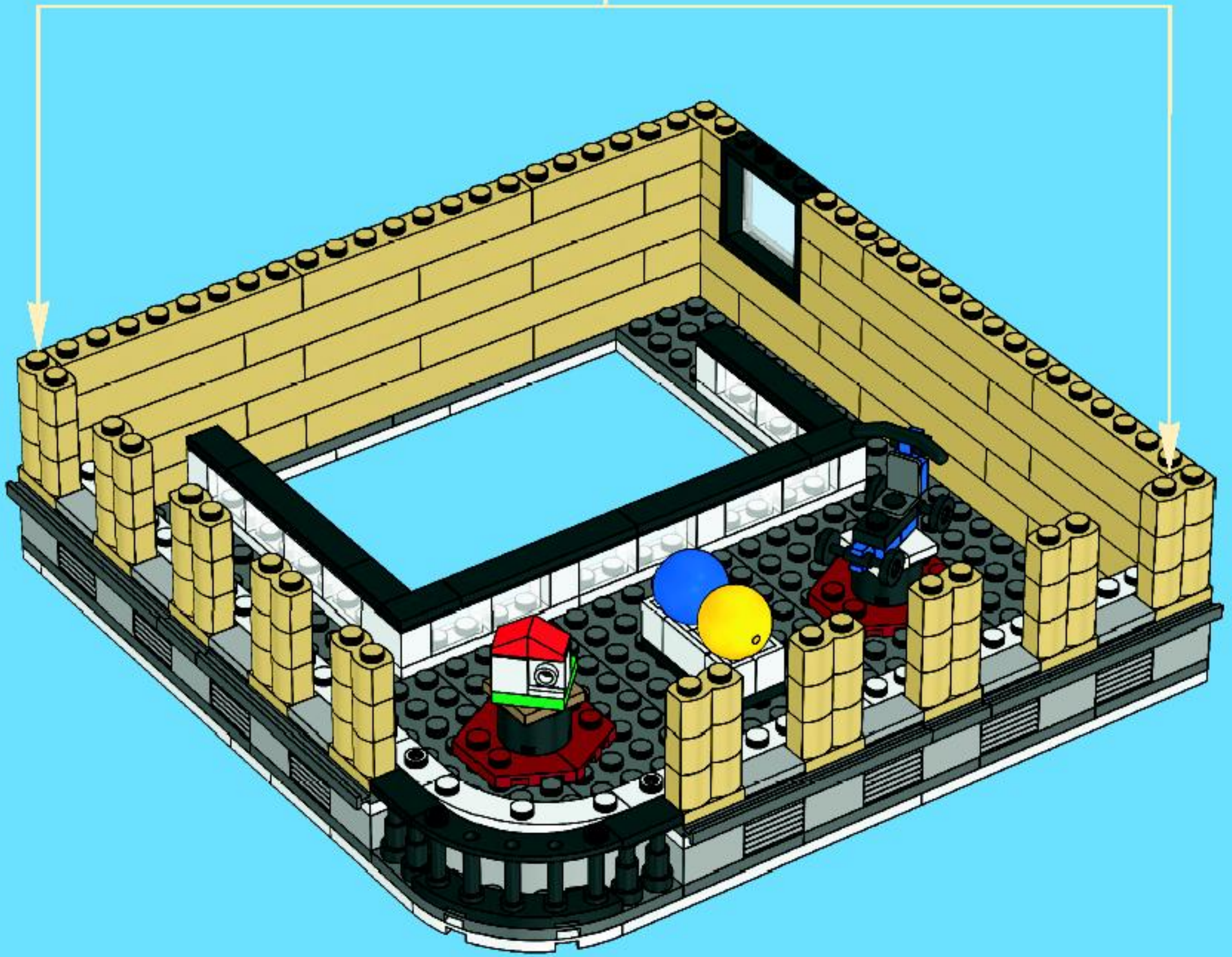



28x



3x

# 19

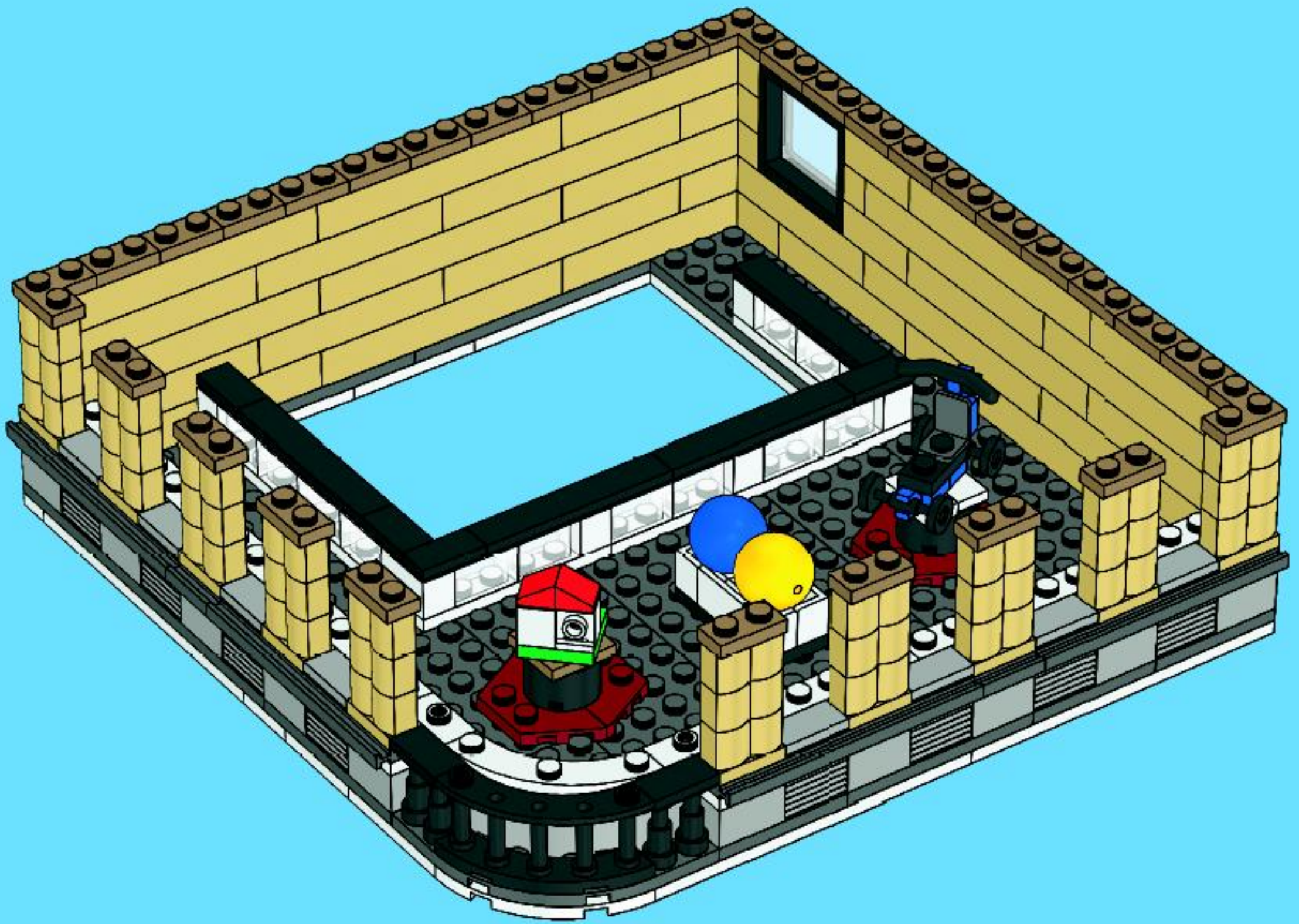

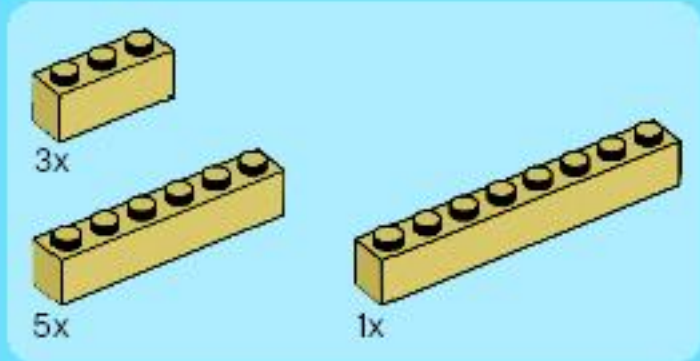

20

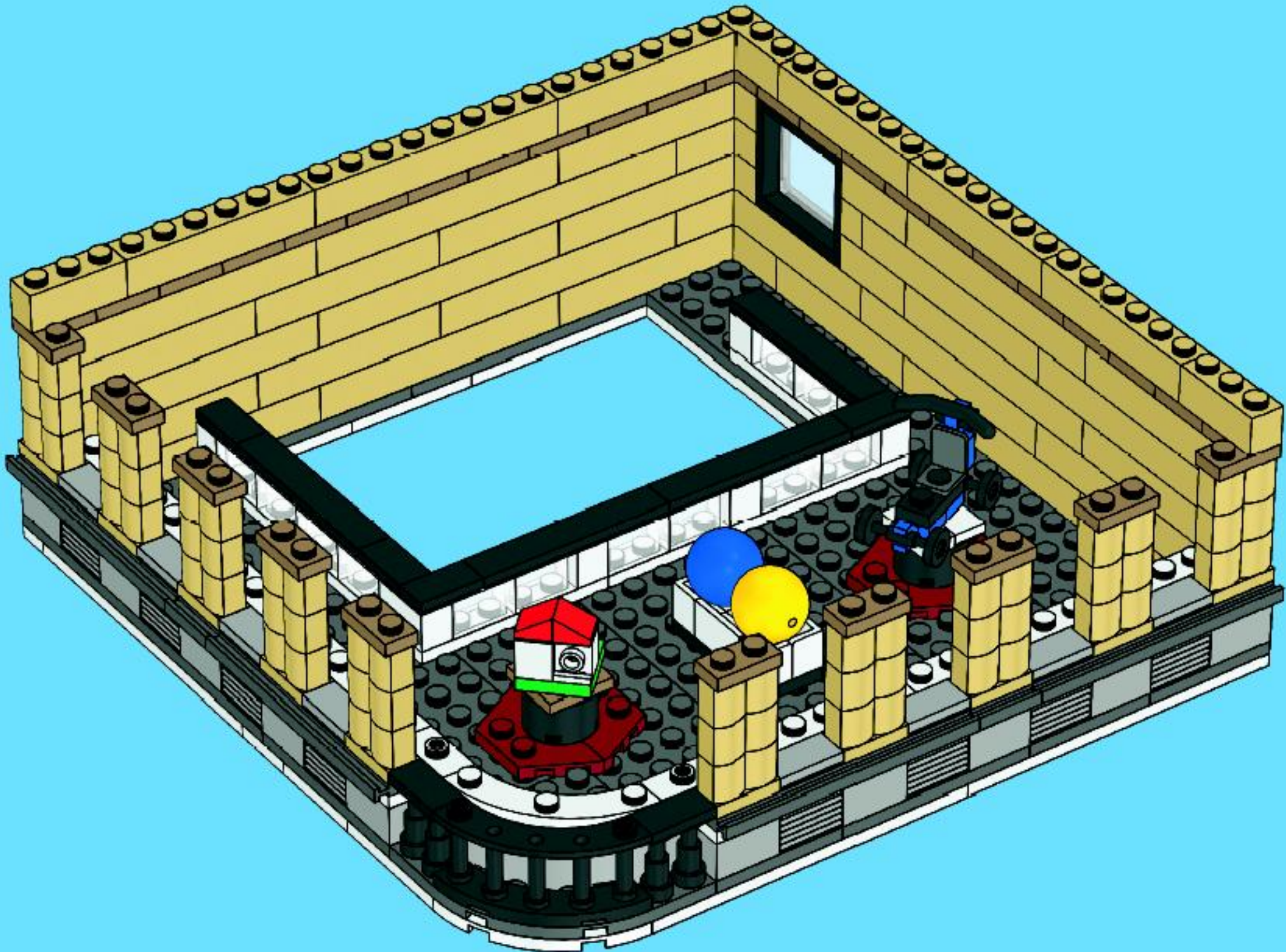

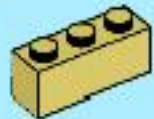

2x

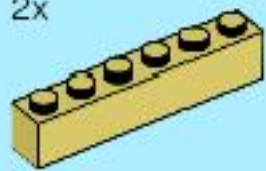

4x

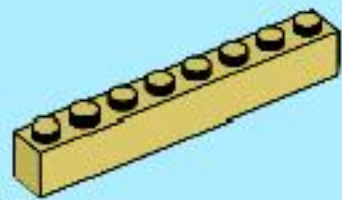

2x

# 21

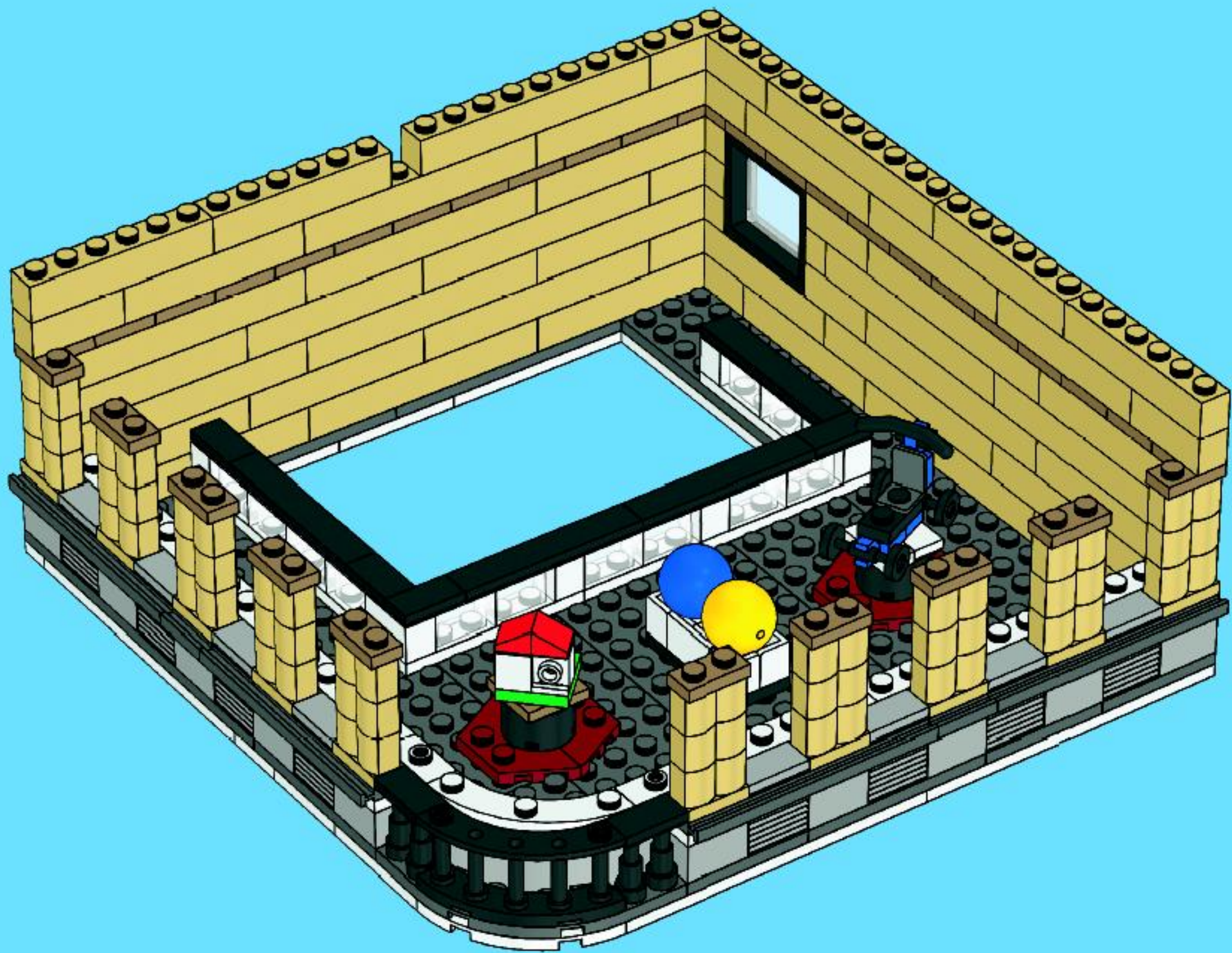

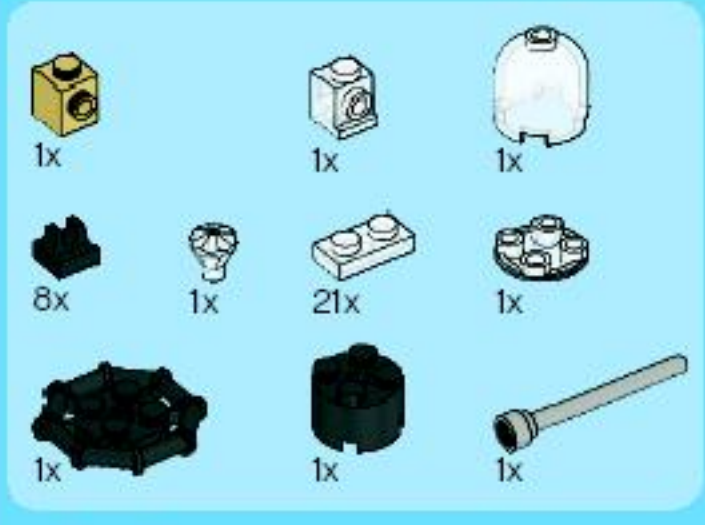

# 22

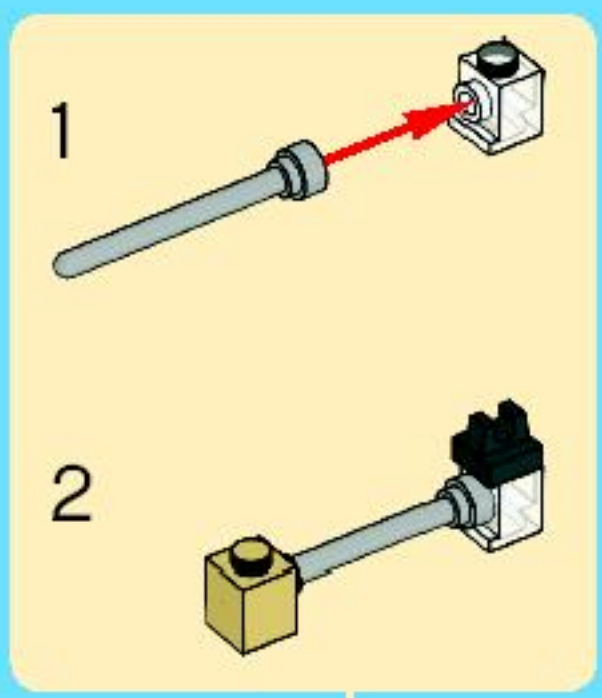
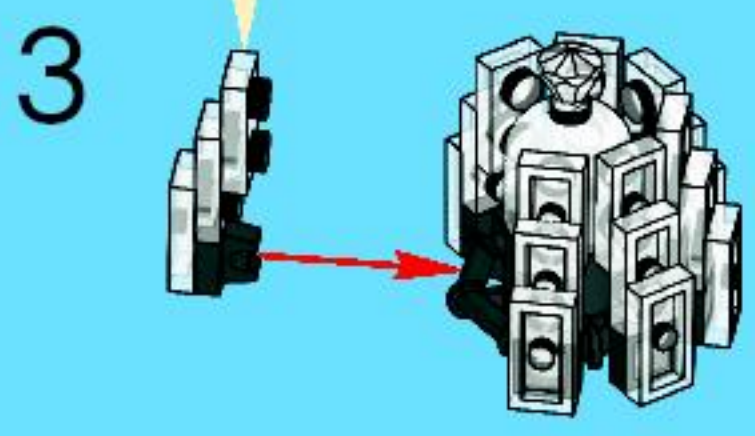
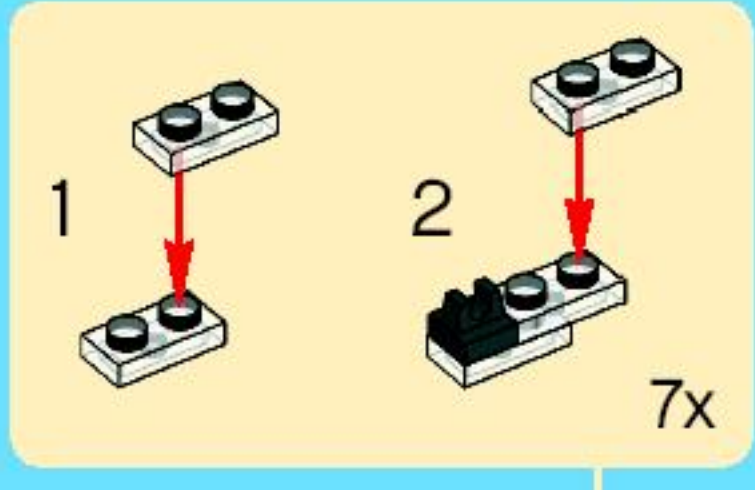
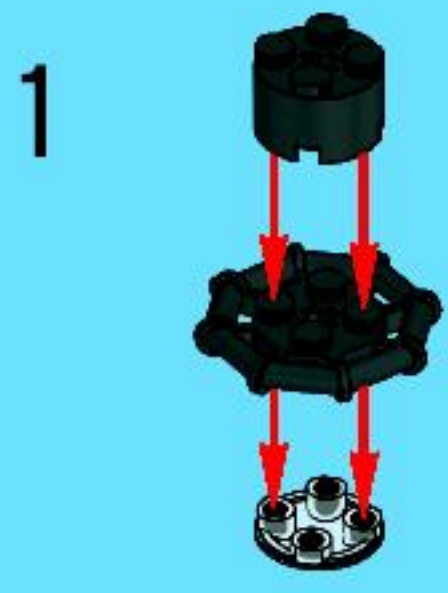



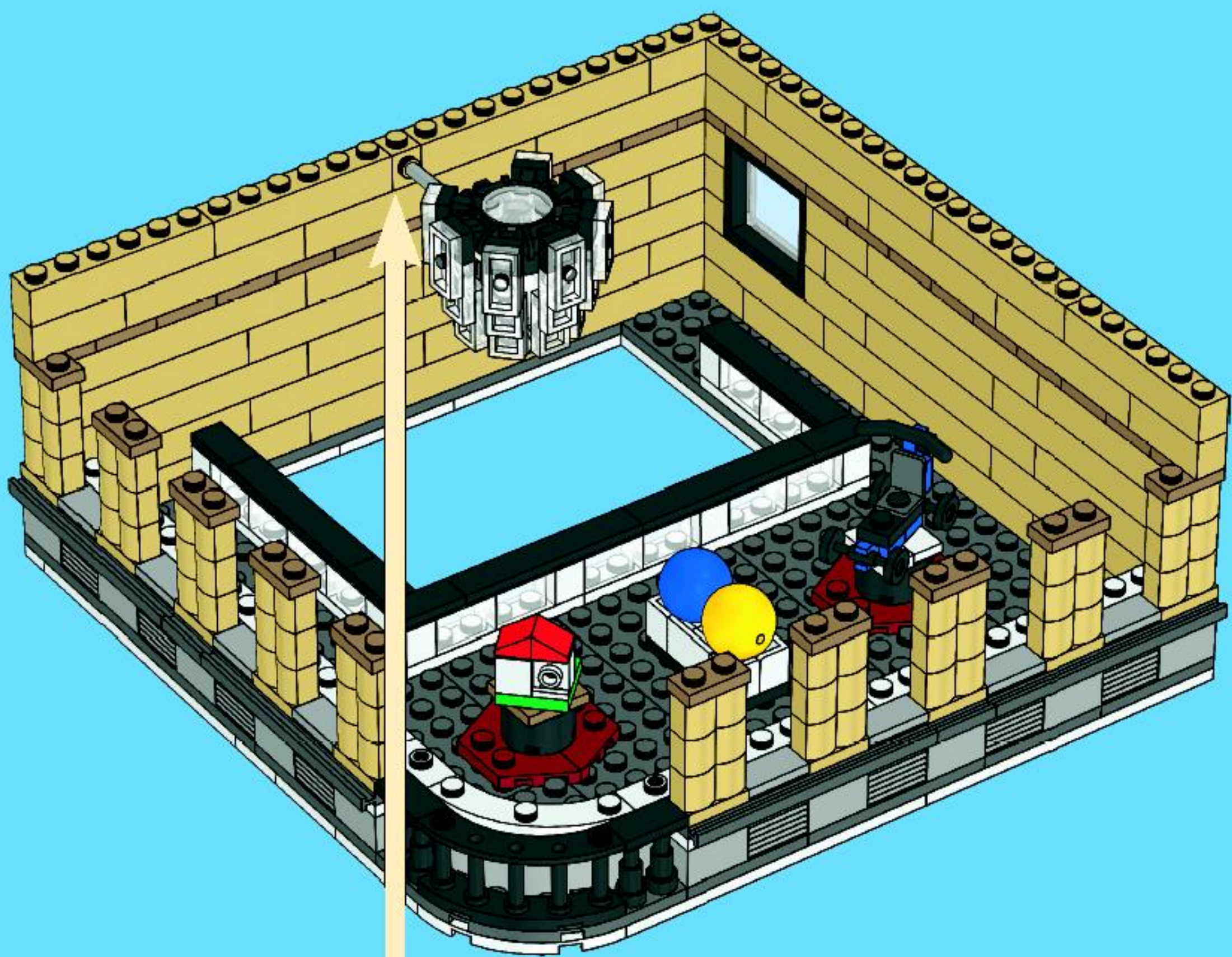



23

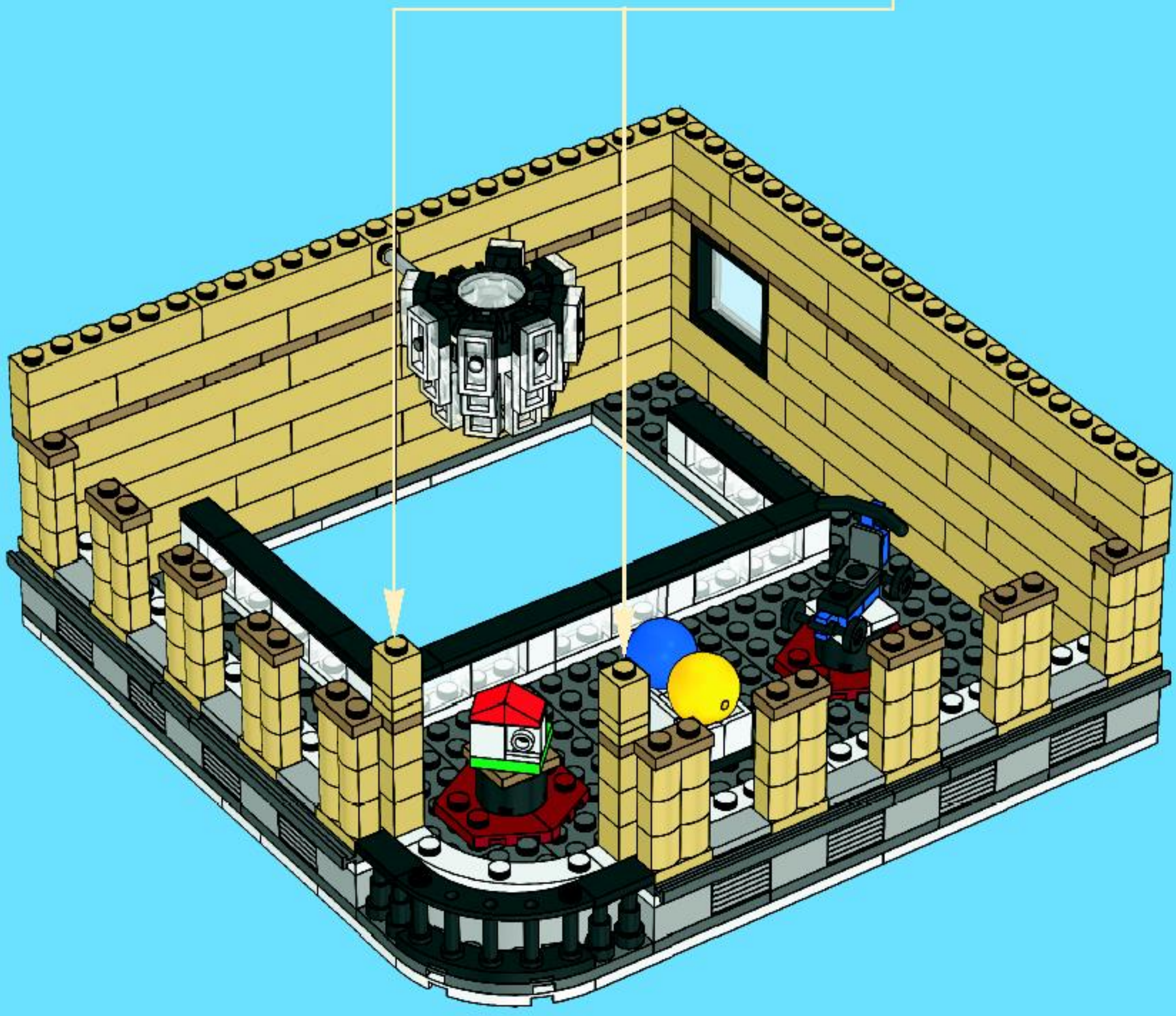
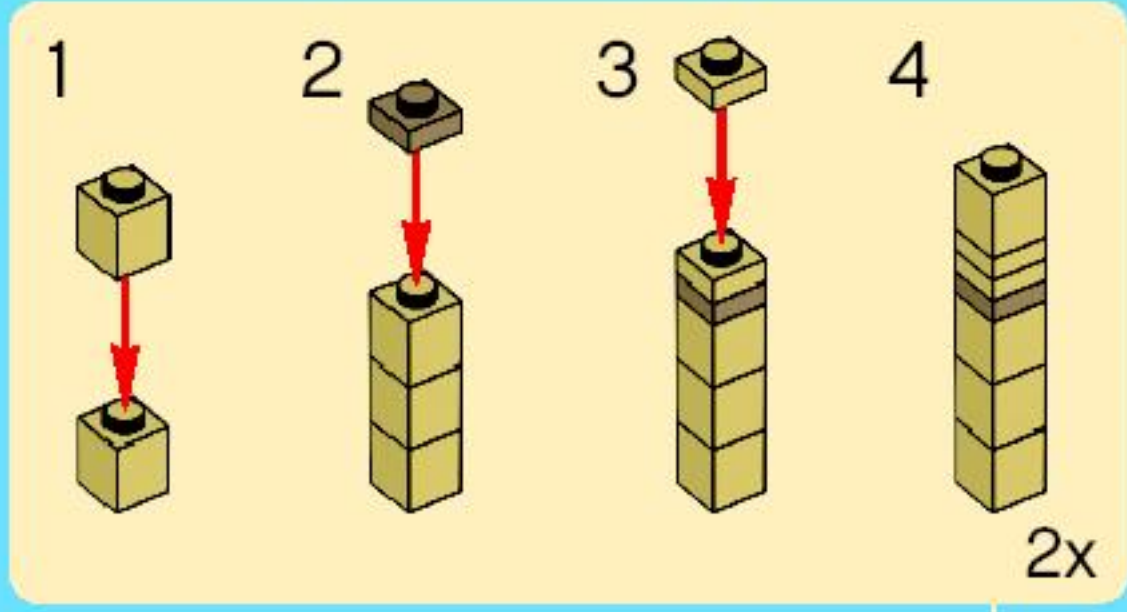



19x



19x

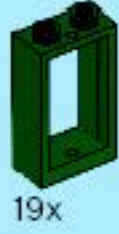

19x



19x

# 24

1

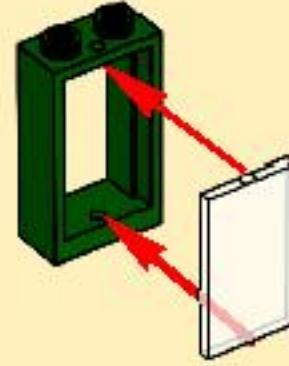

2

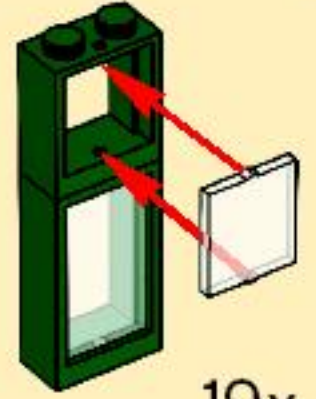

19x

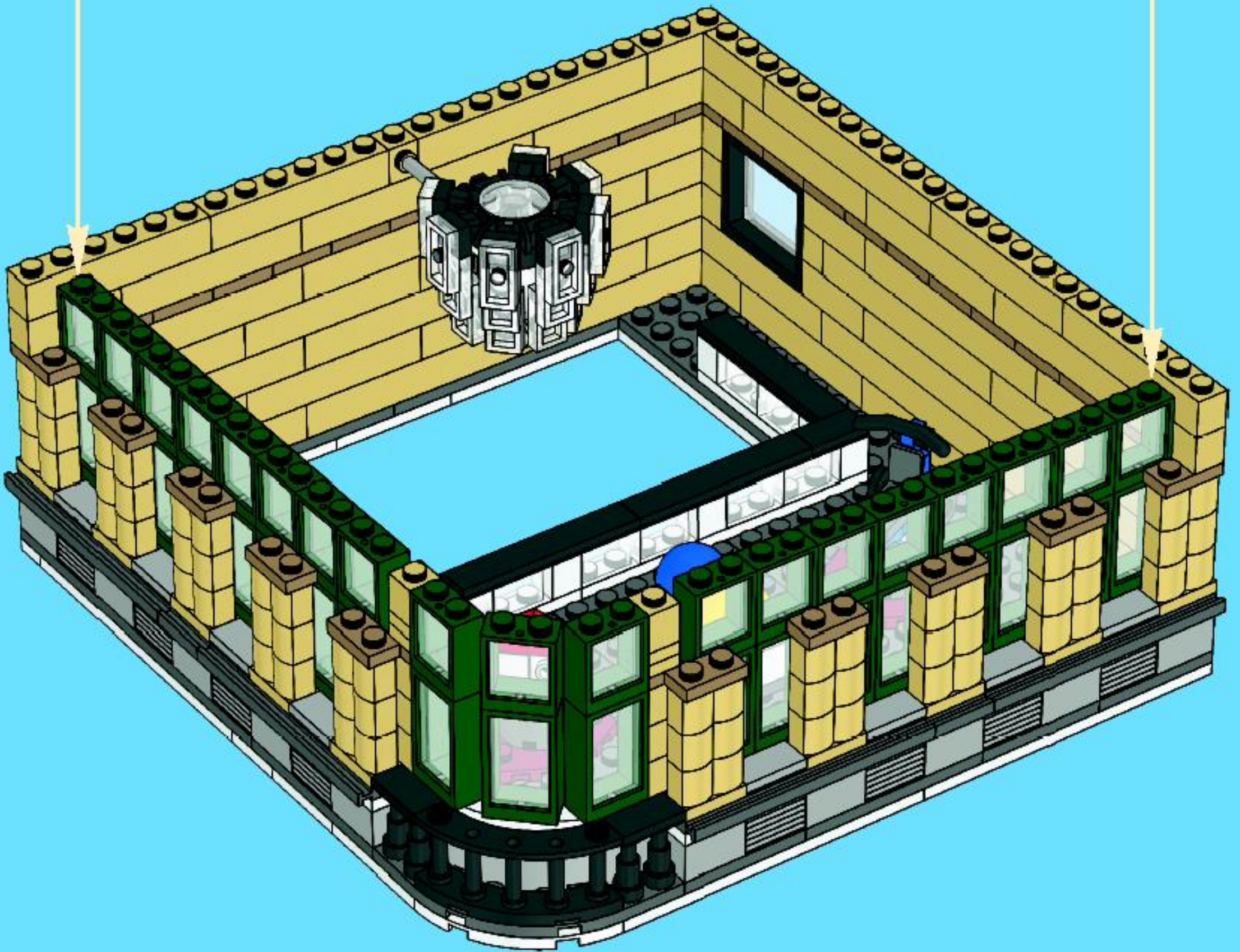

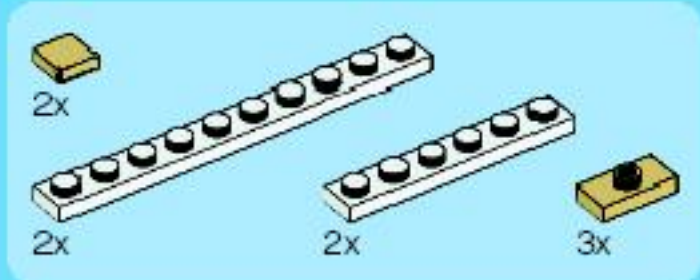

25

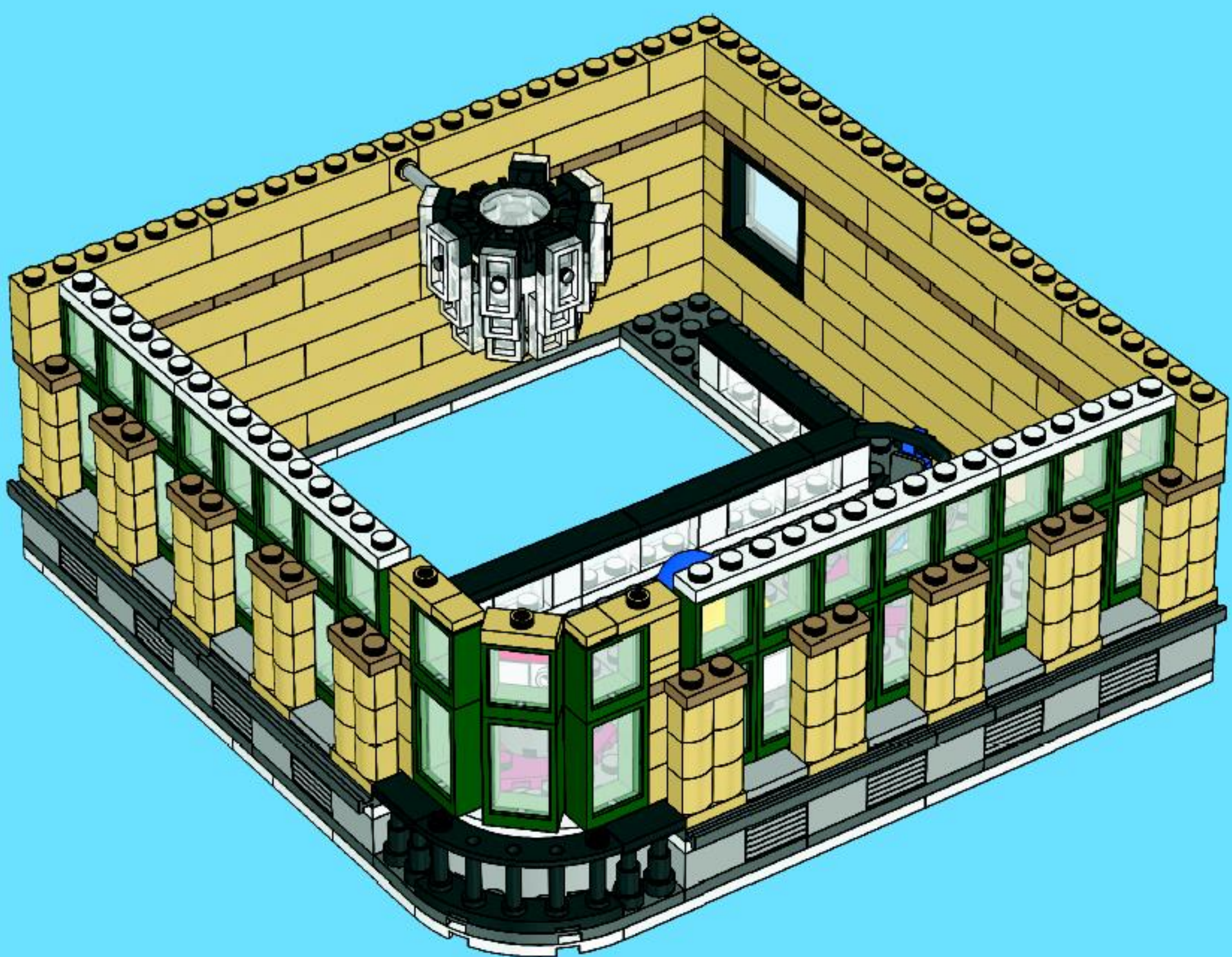

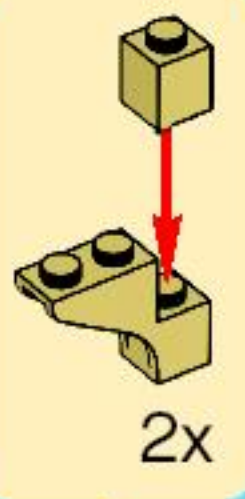
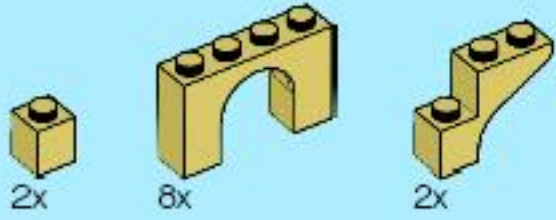

26

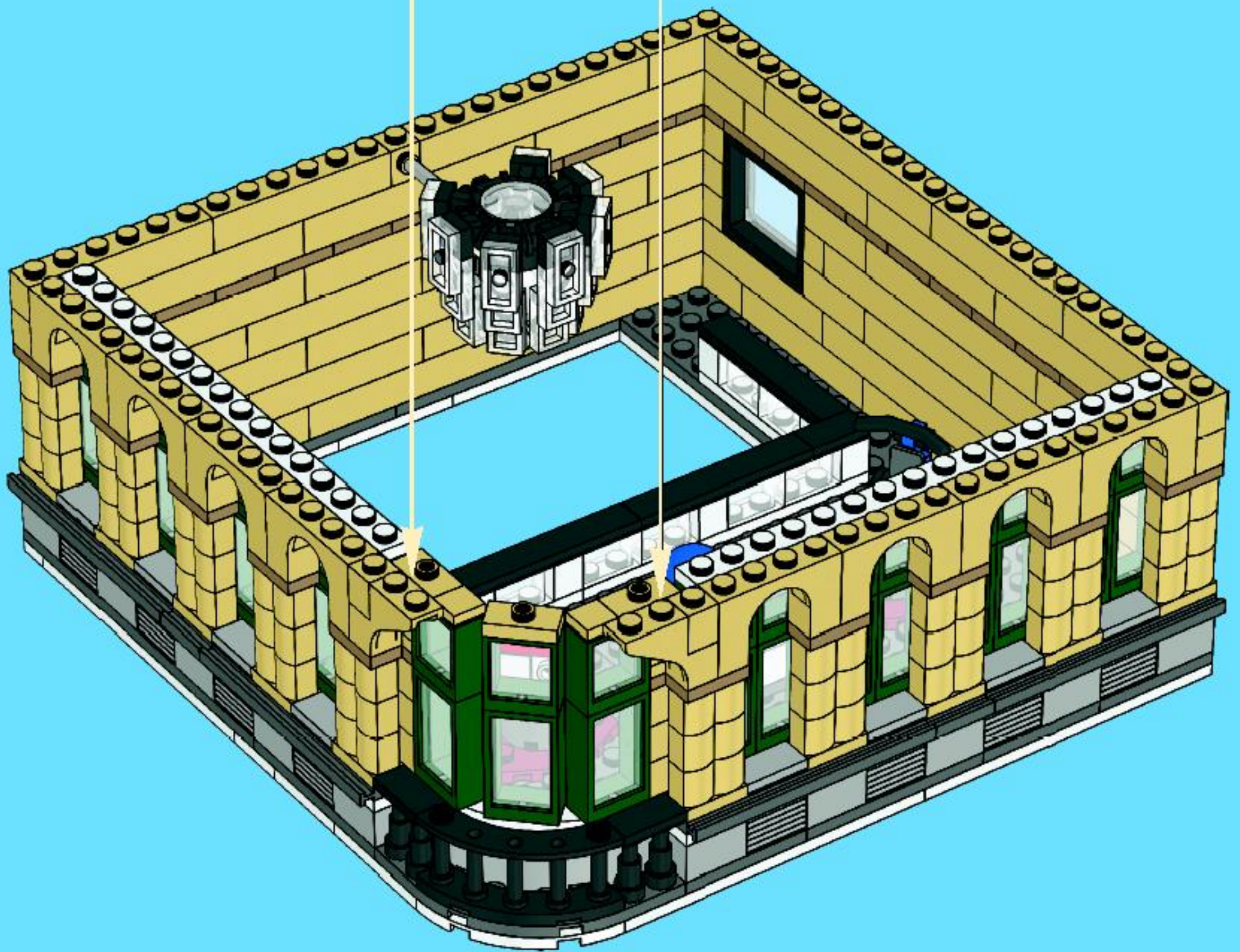

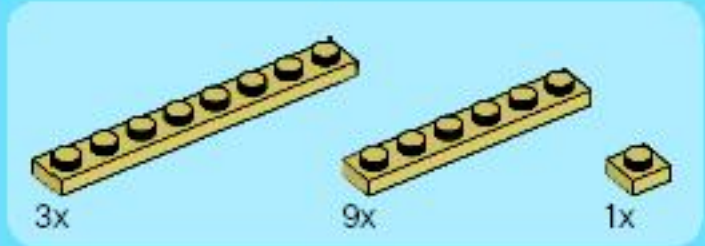

27

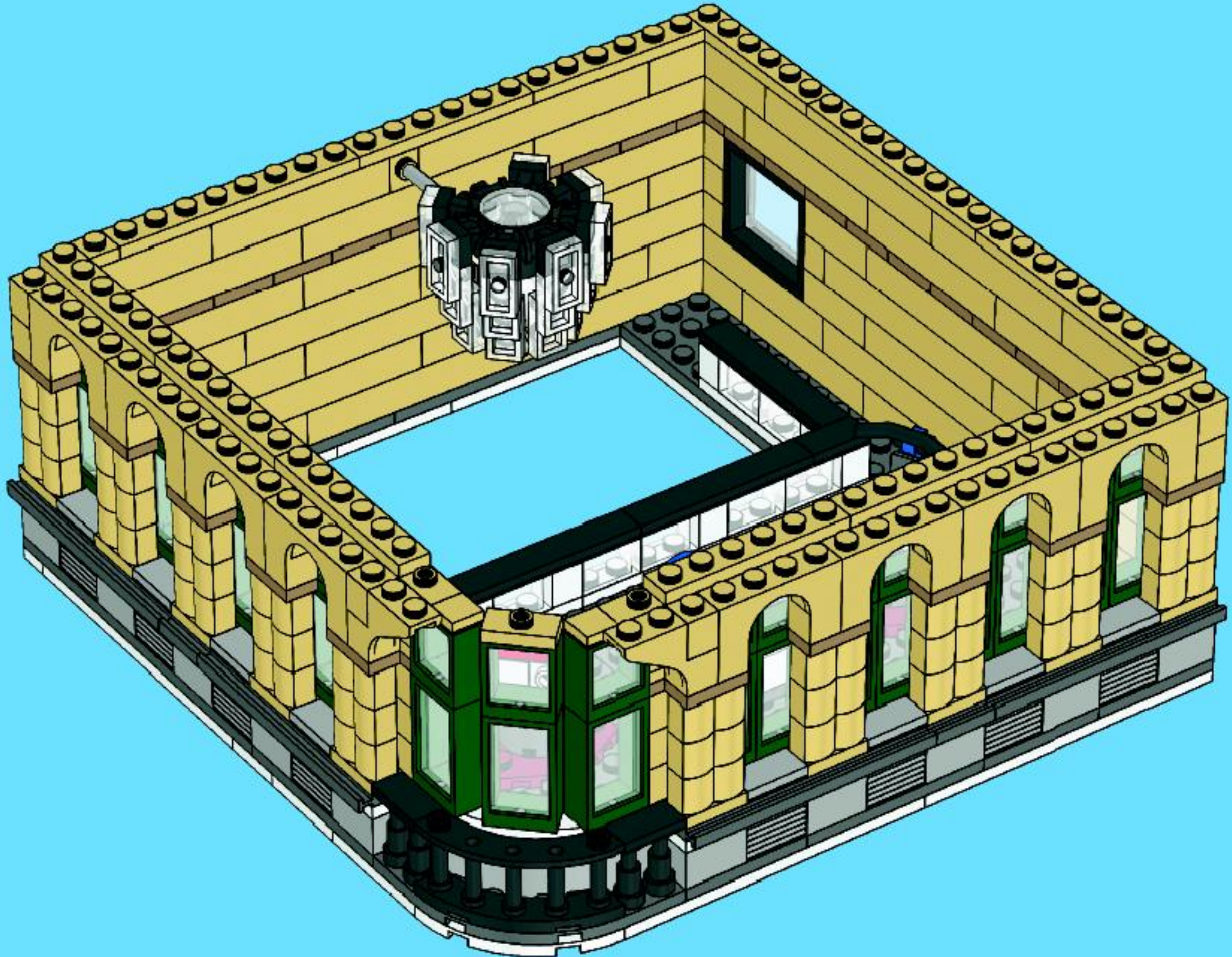

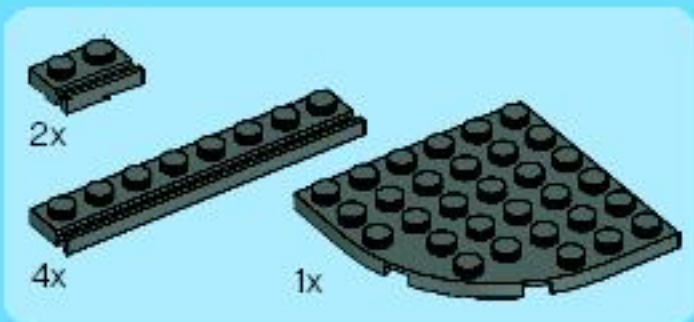

28

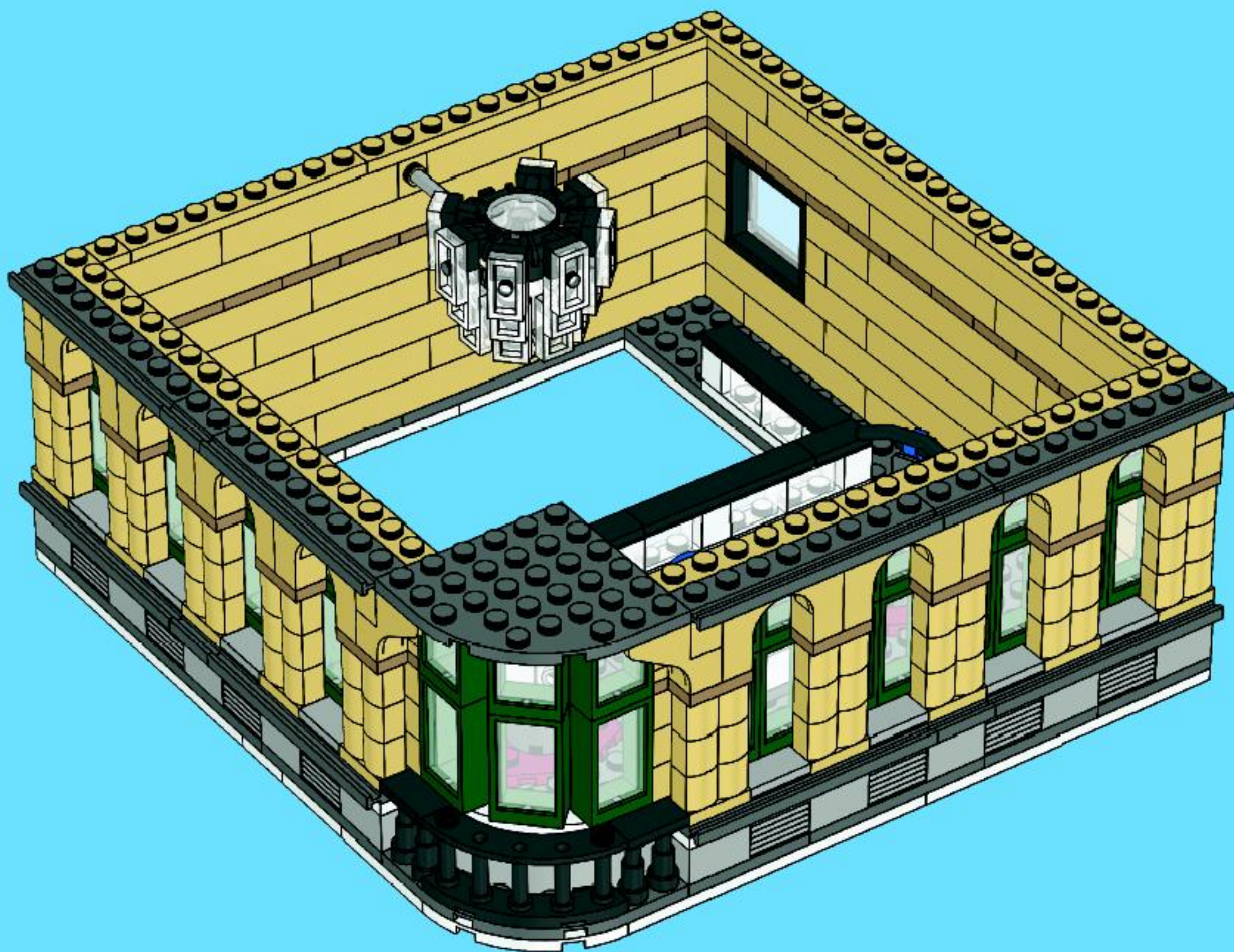

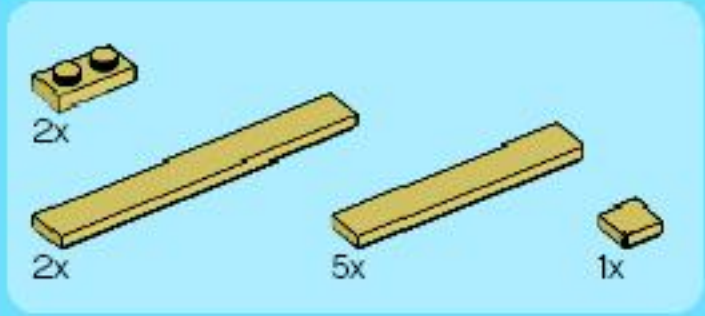

# 29

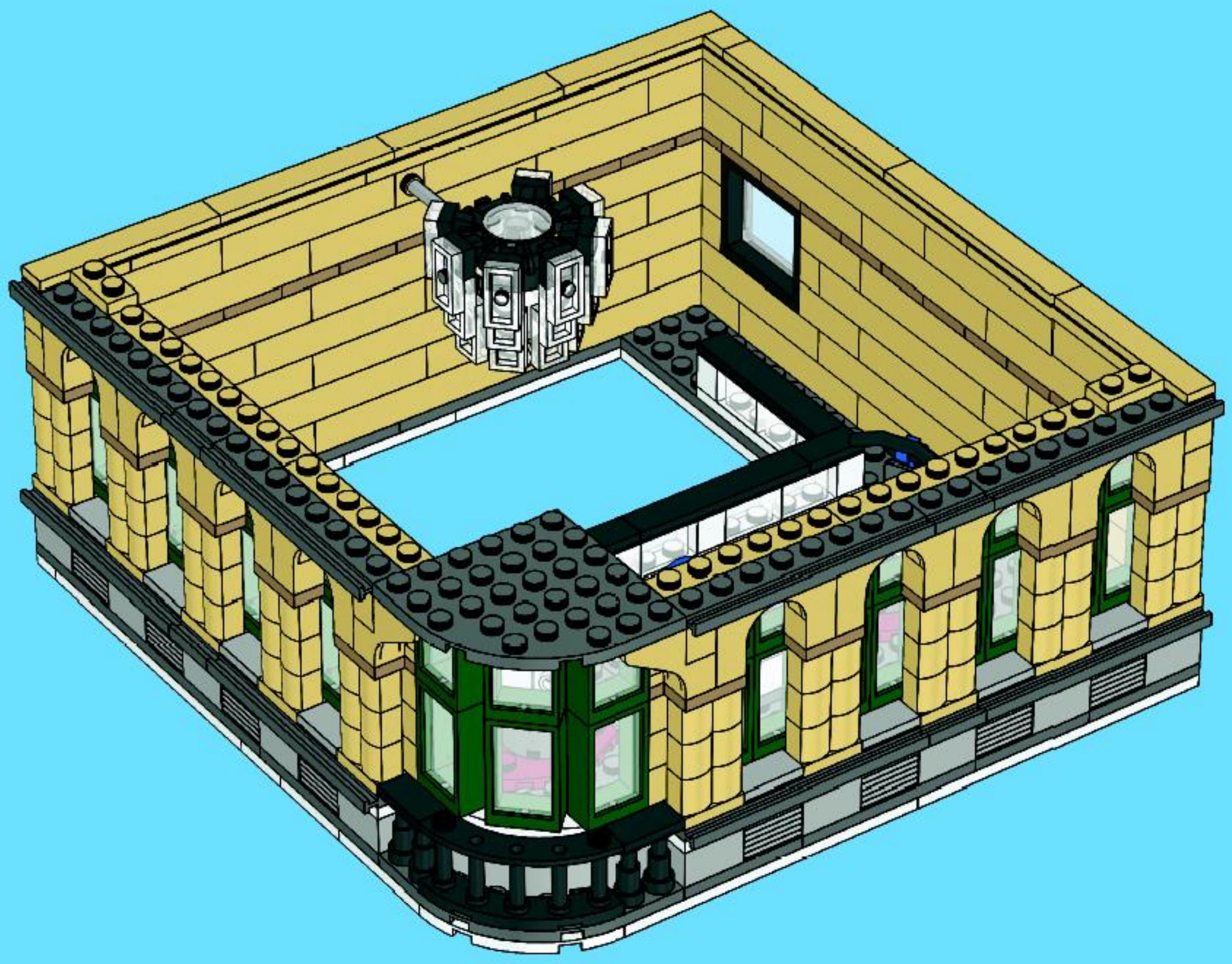



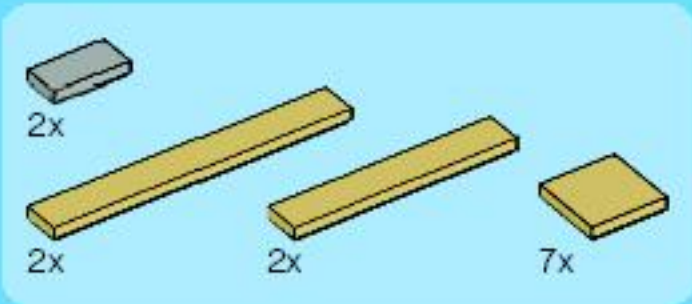

30

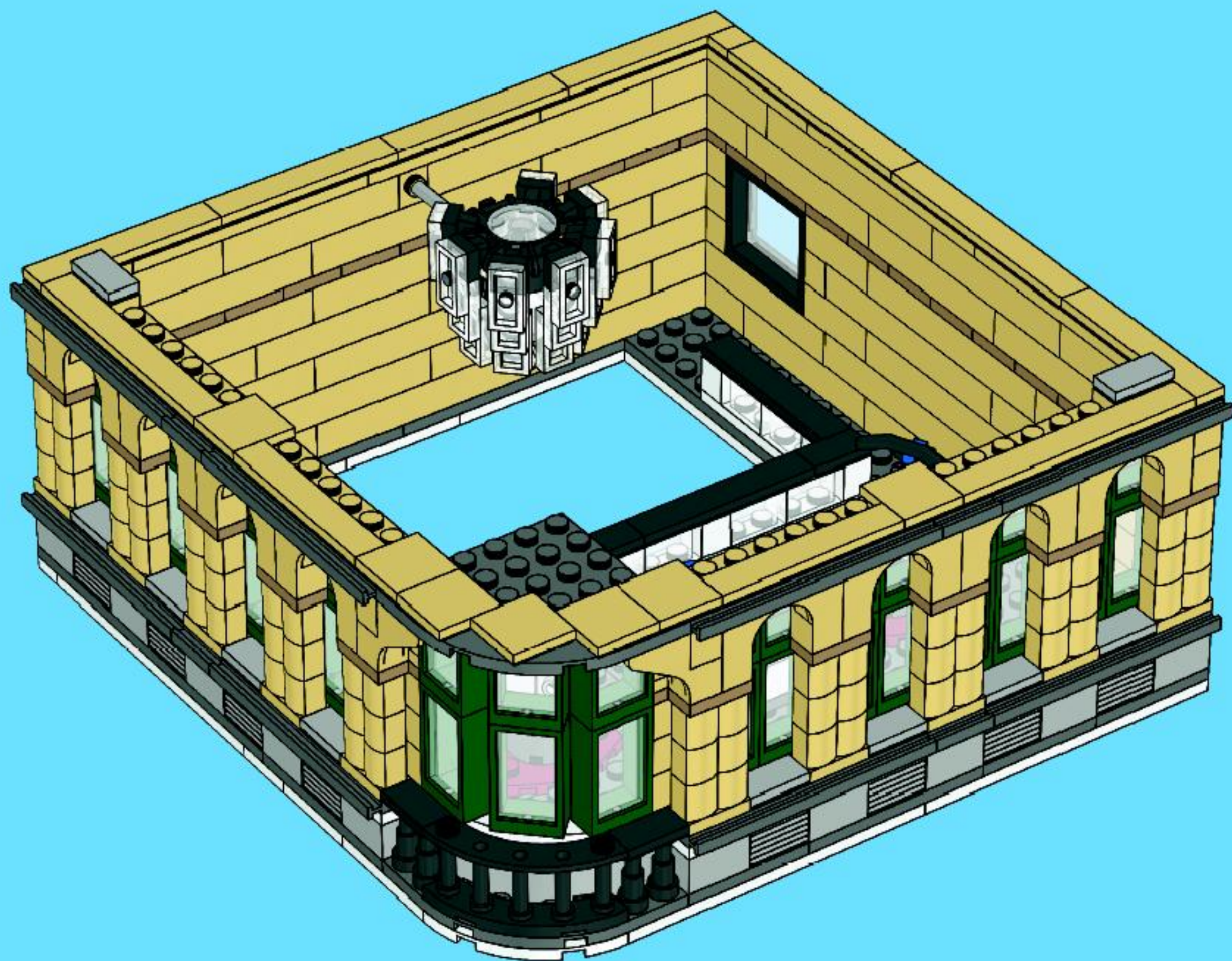

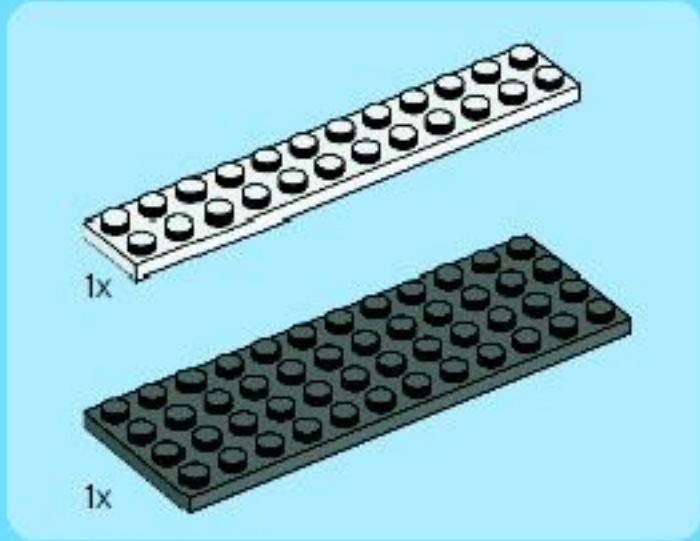
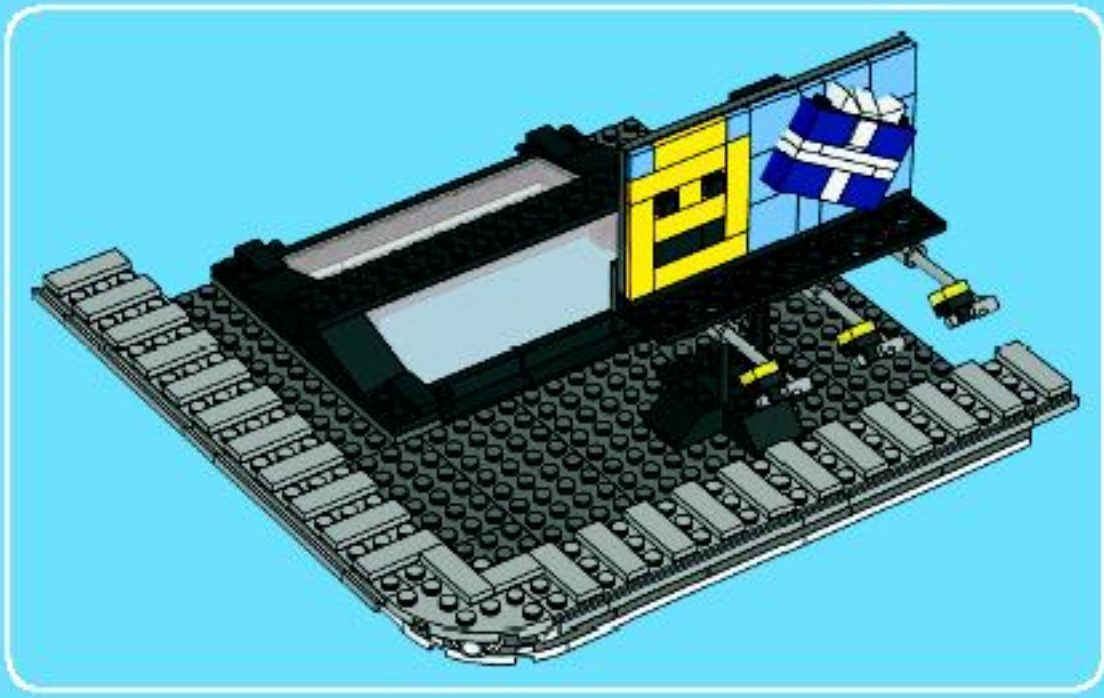

1

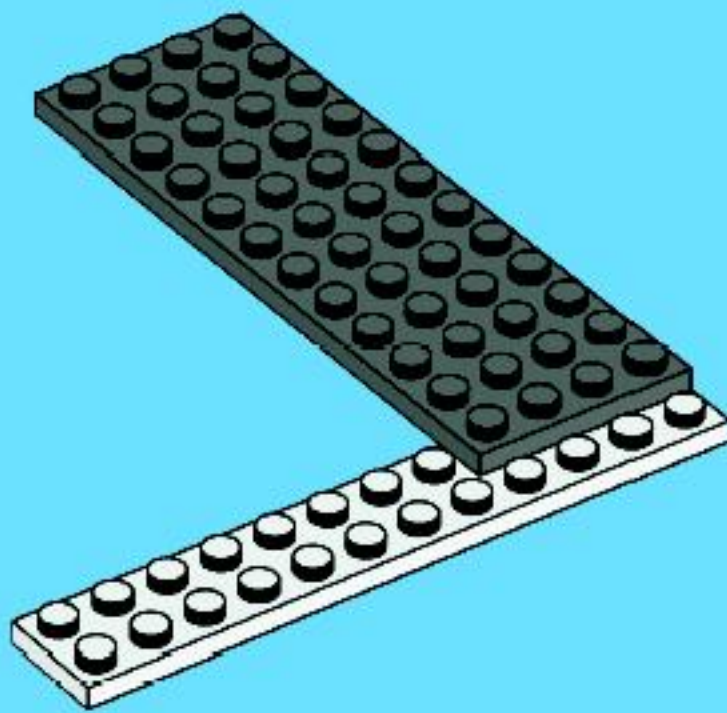

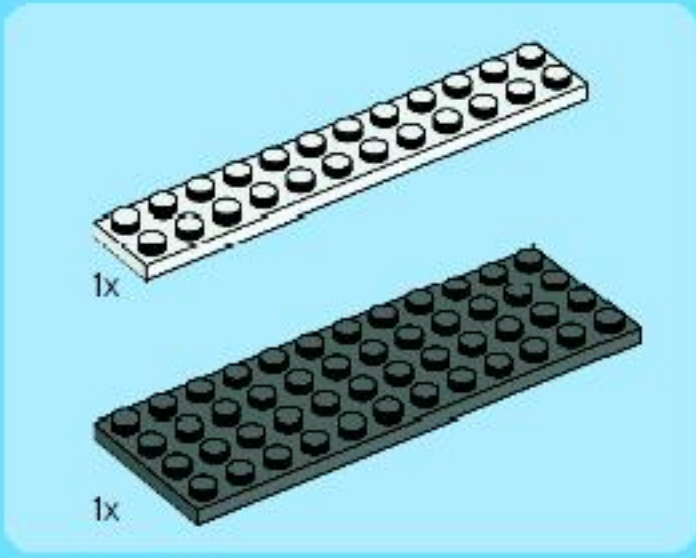

2

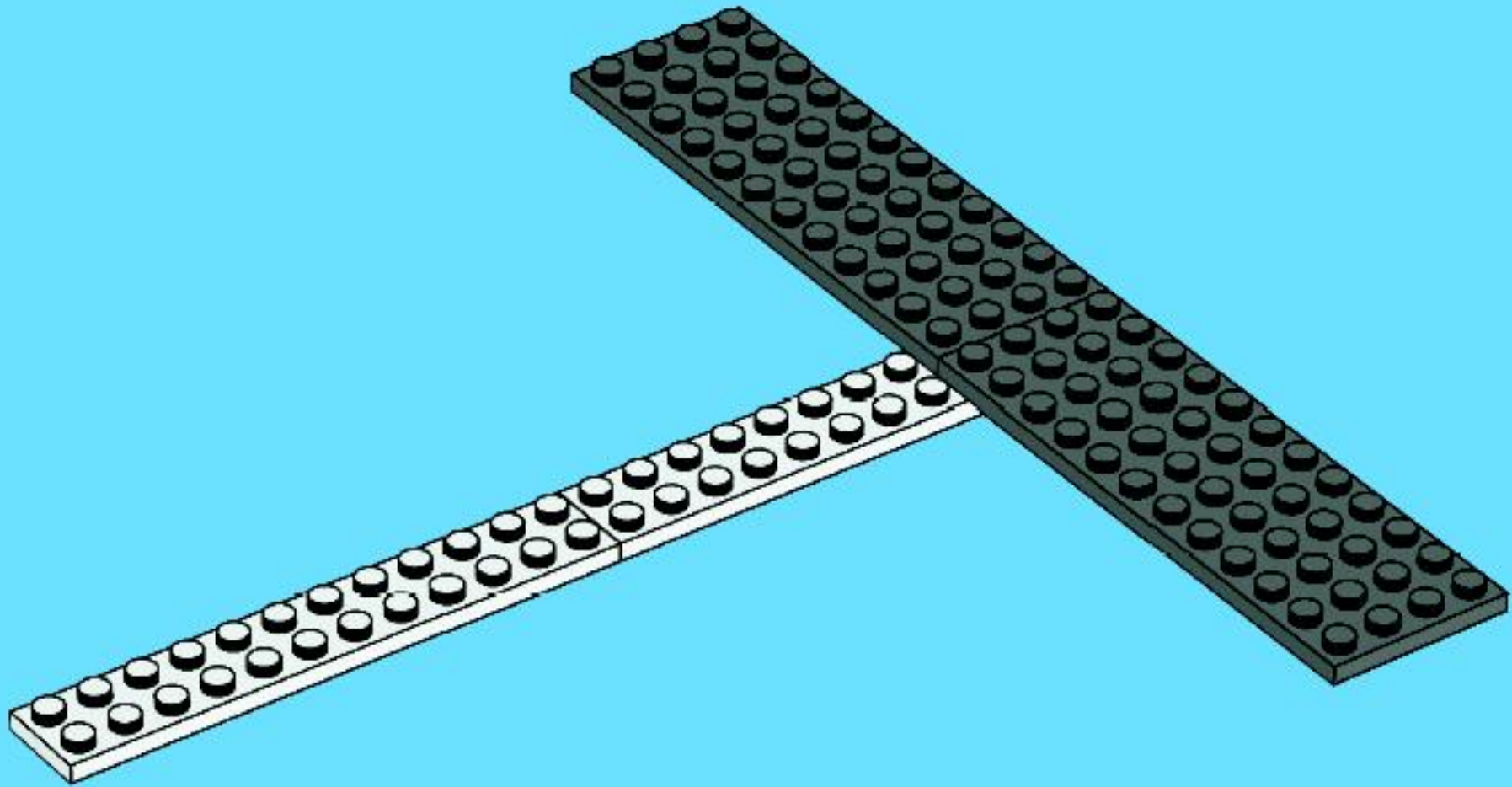

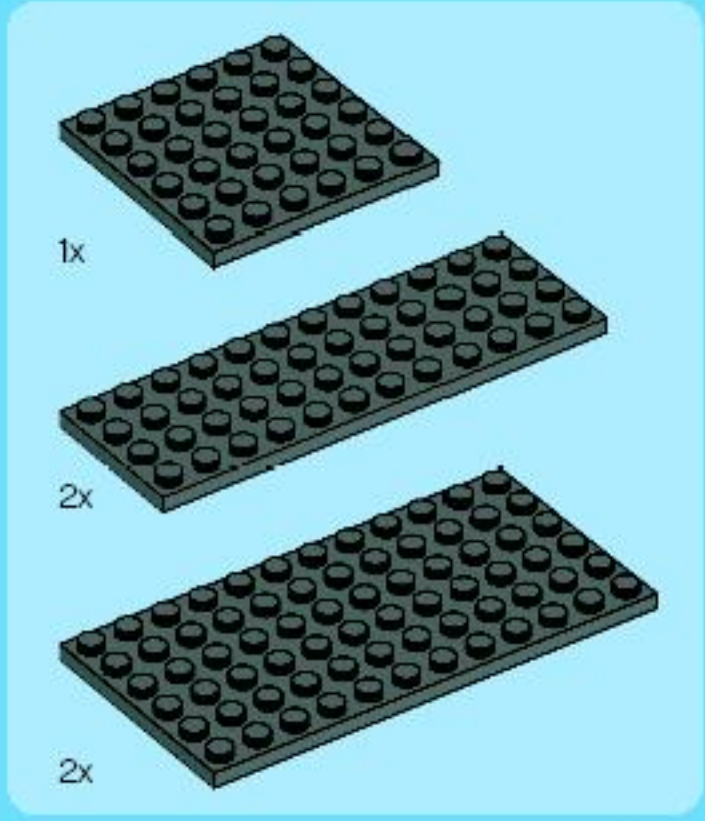

3

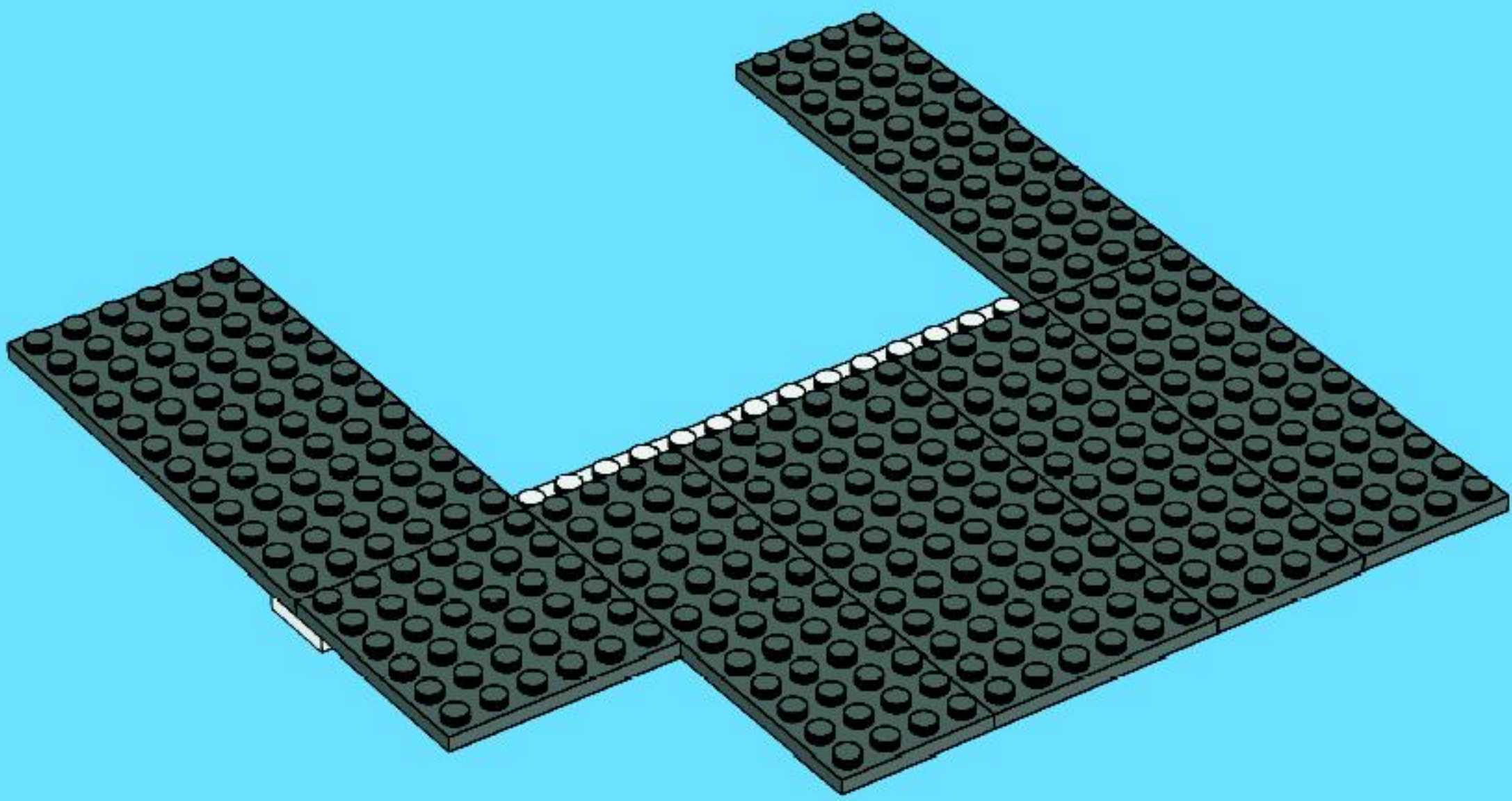

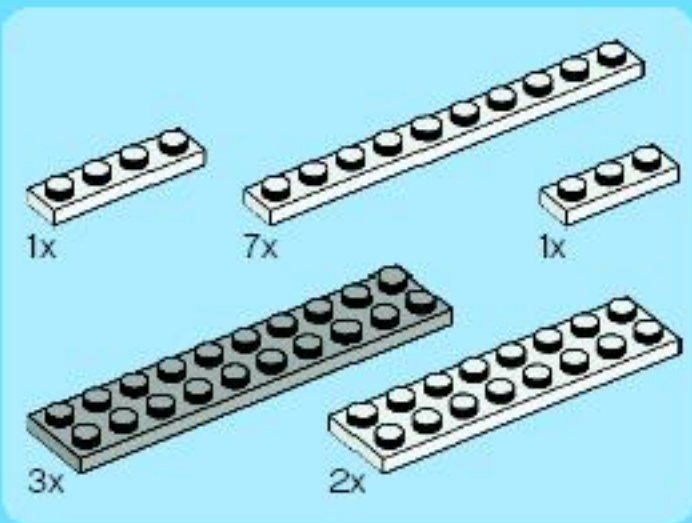

4

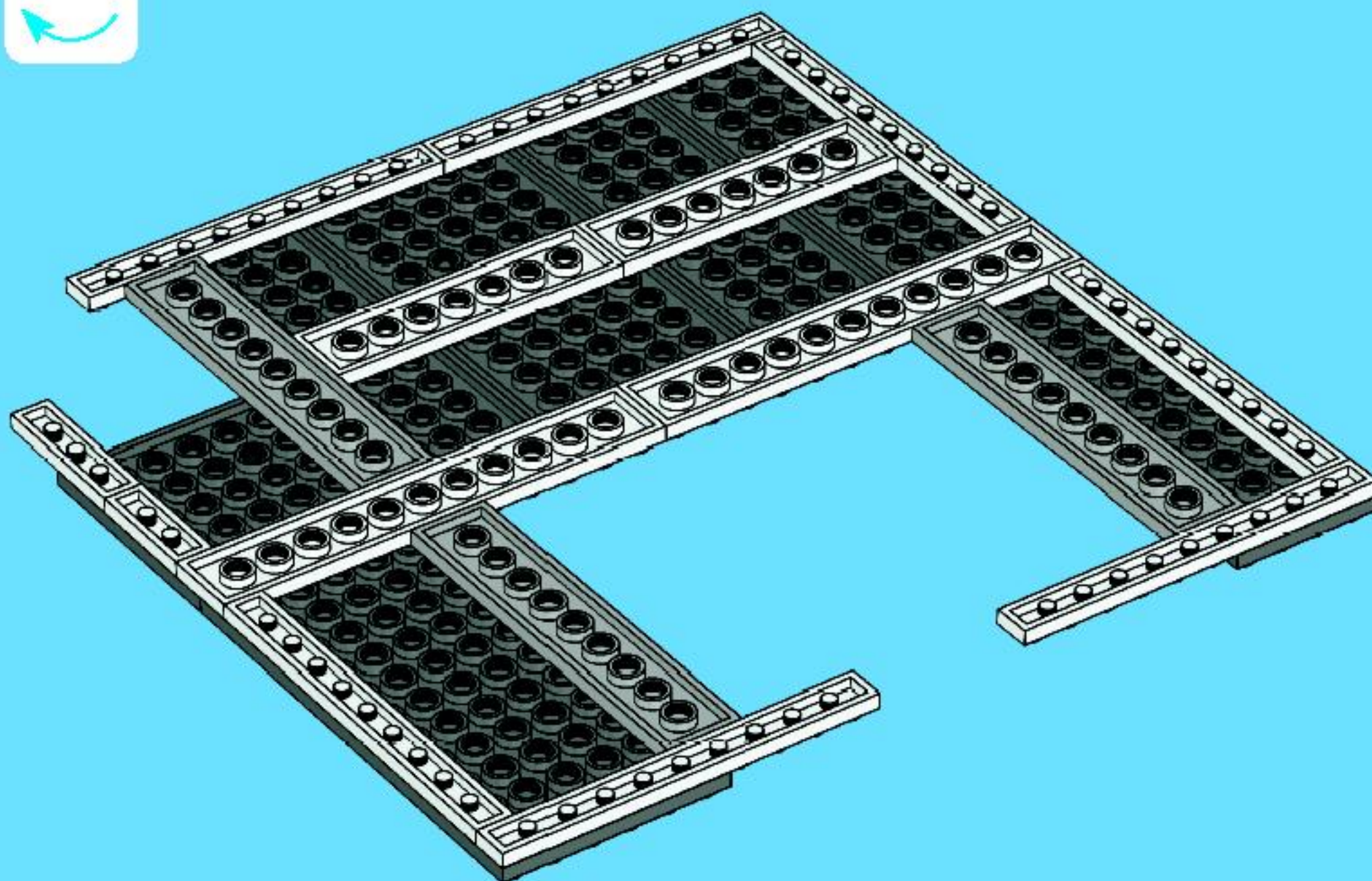

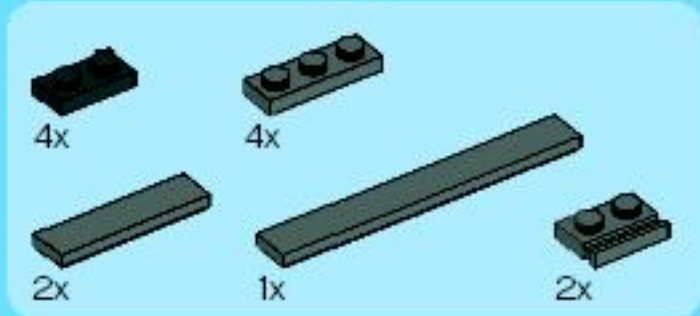

5

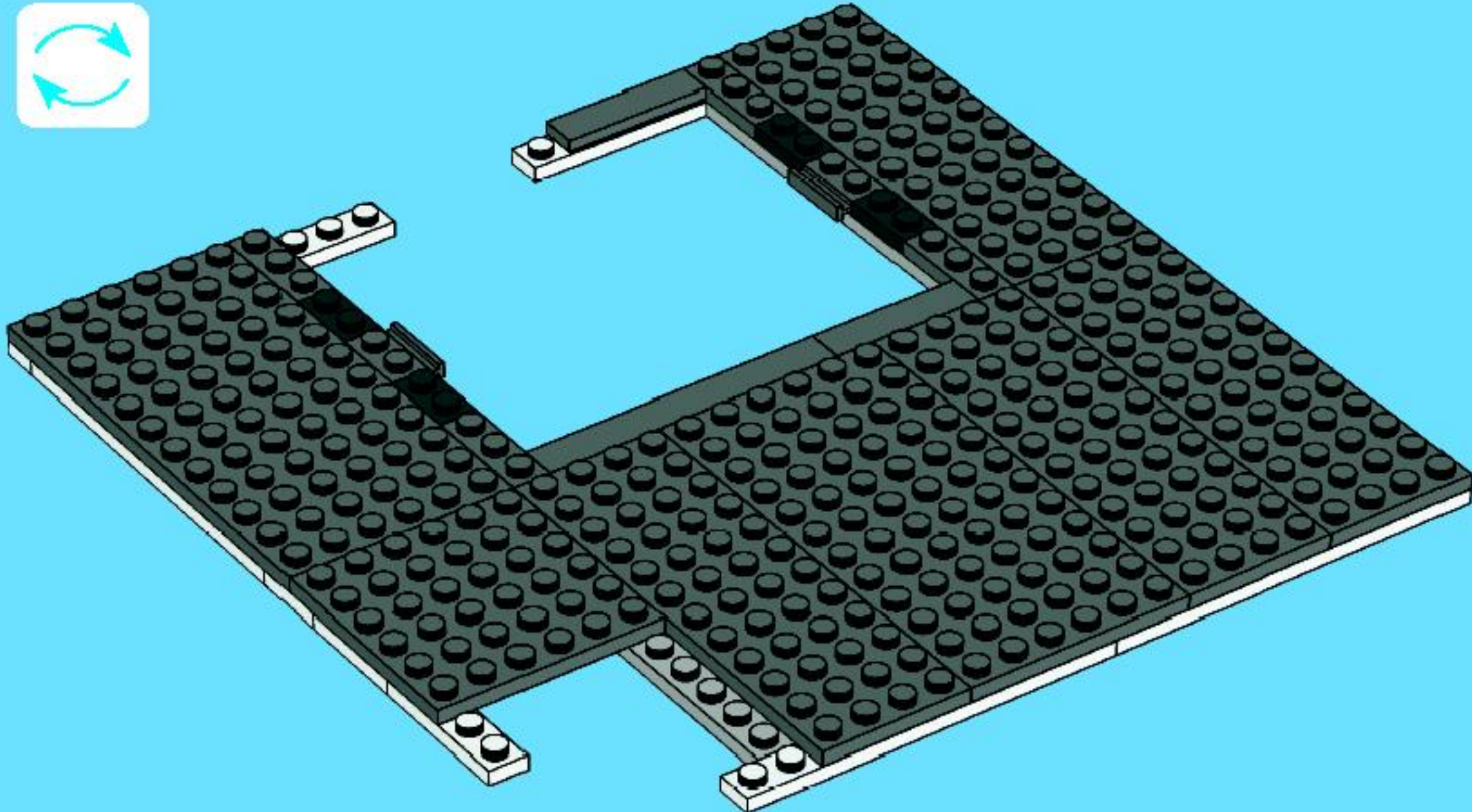

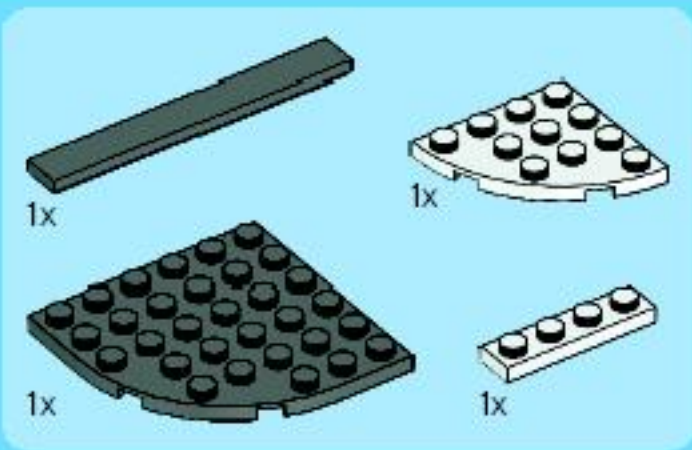

6

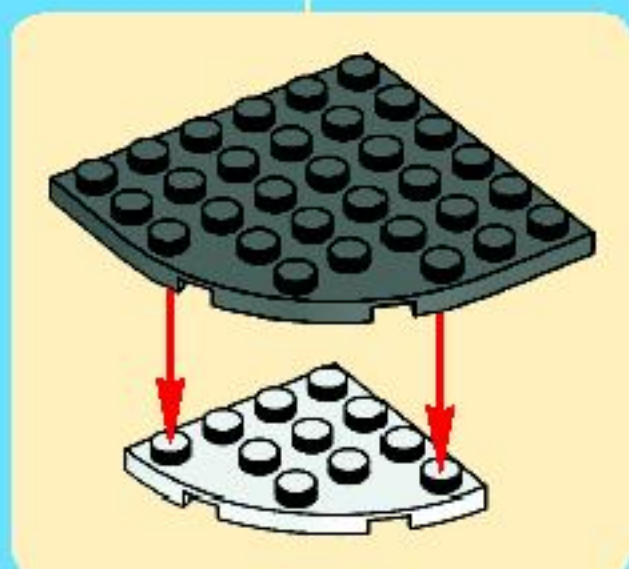
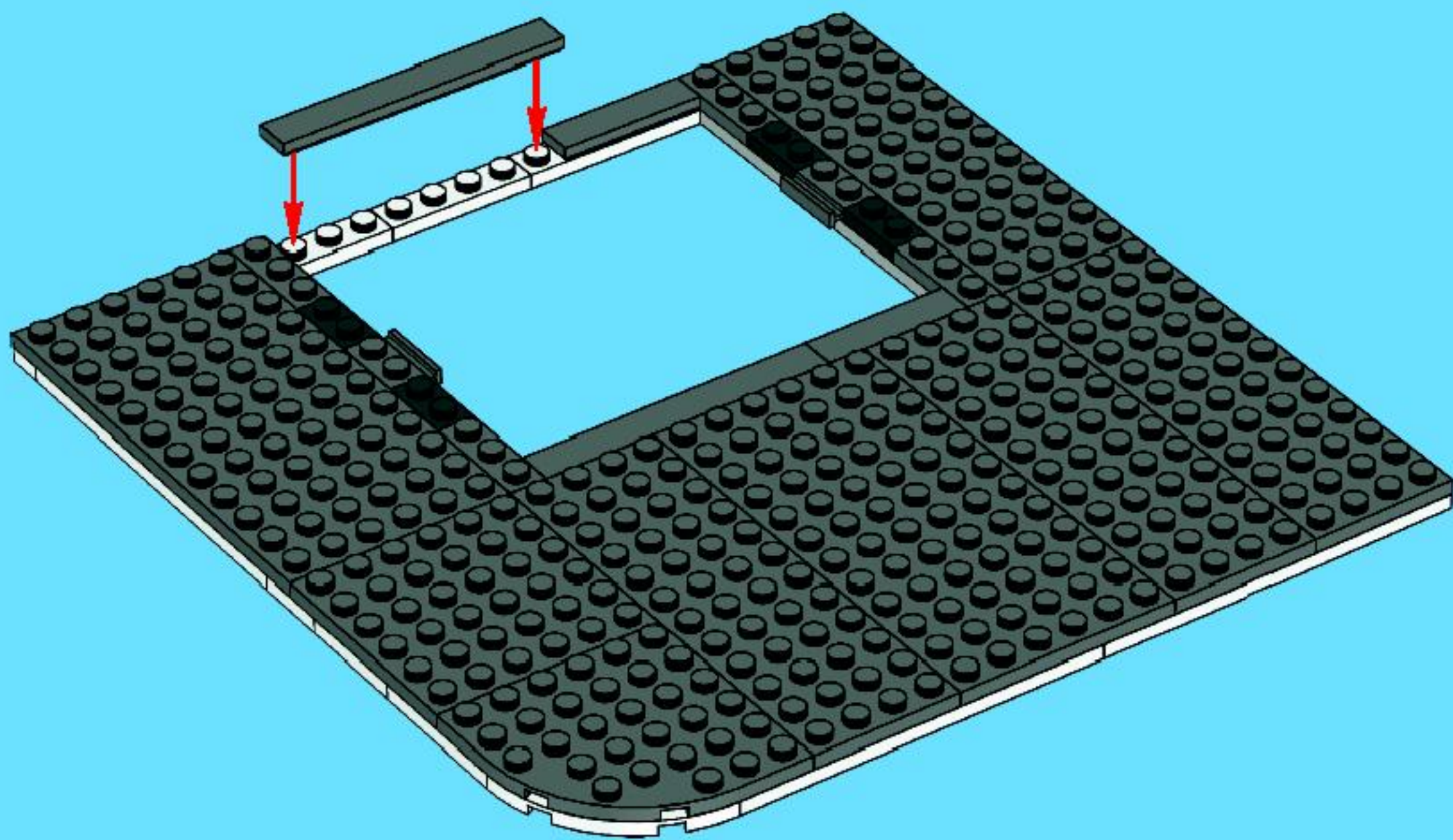

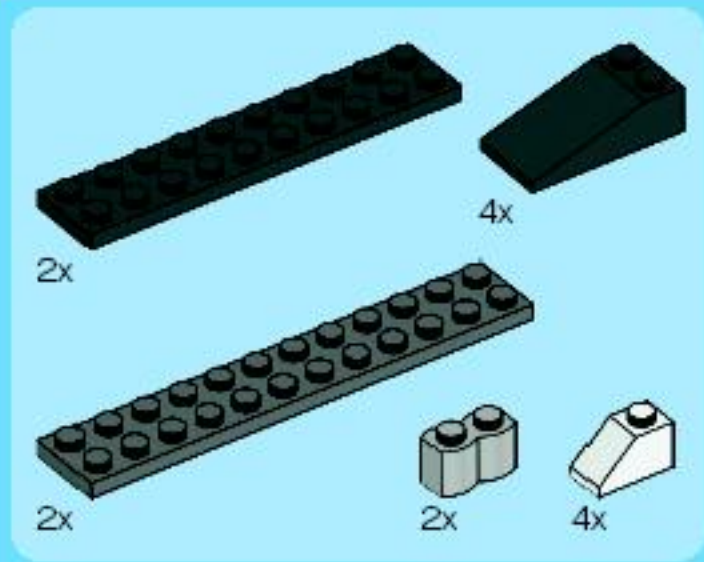

7

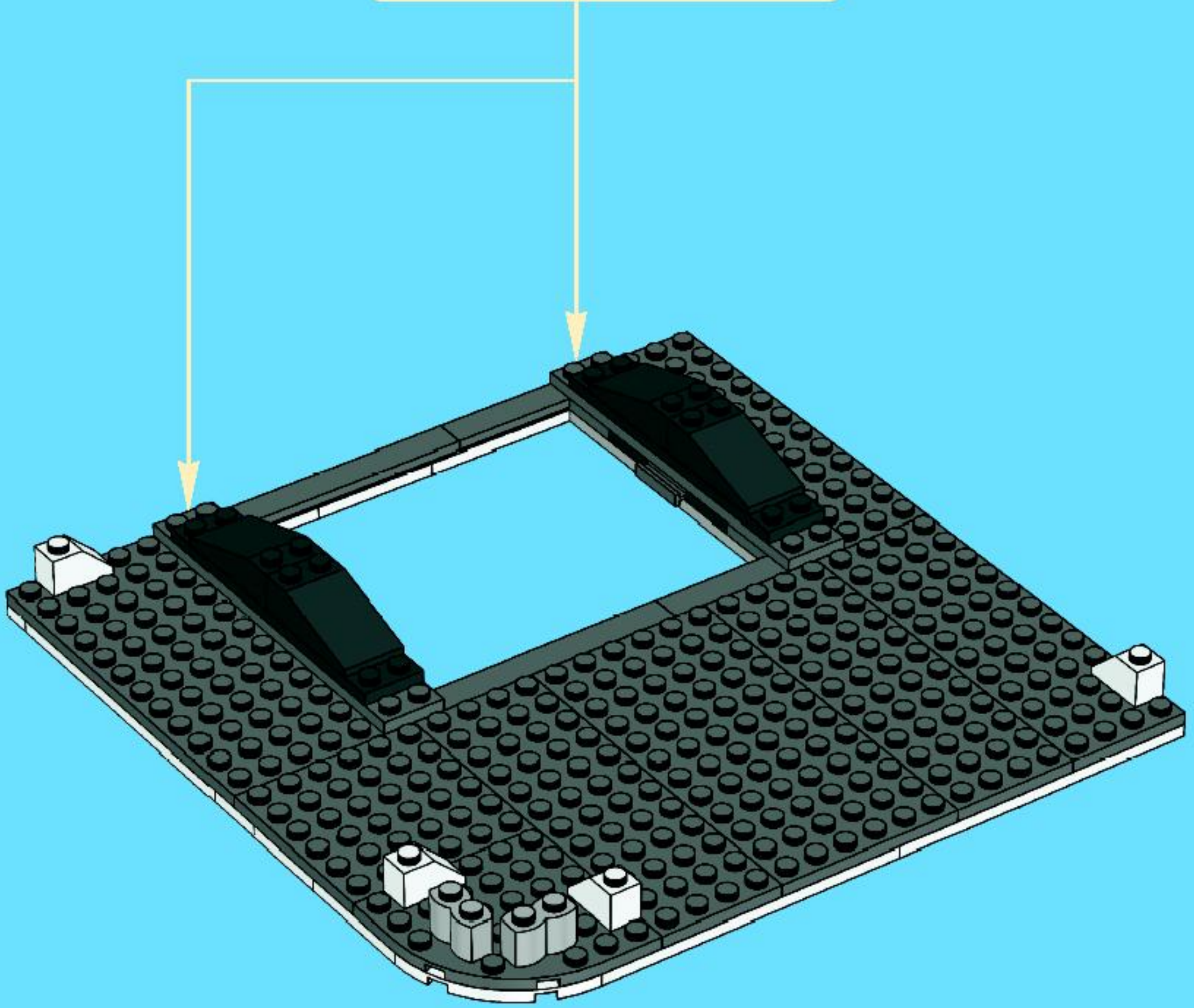
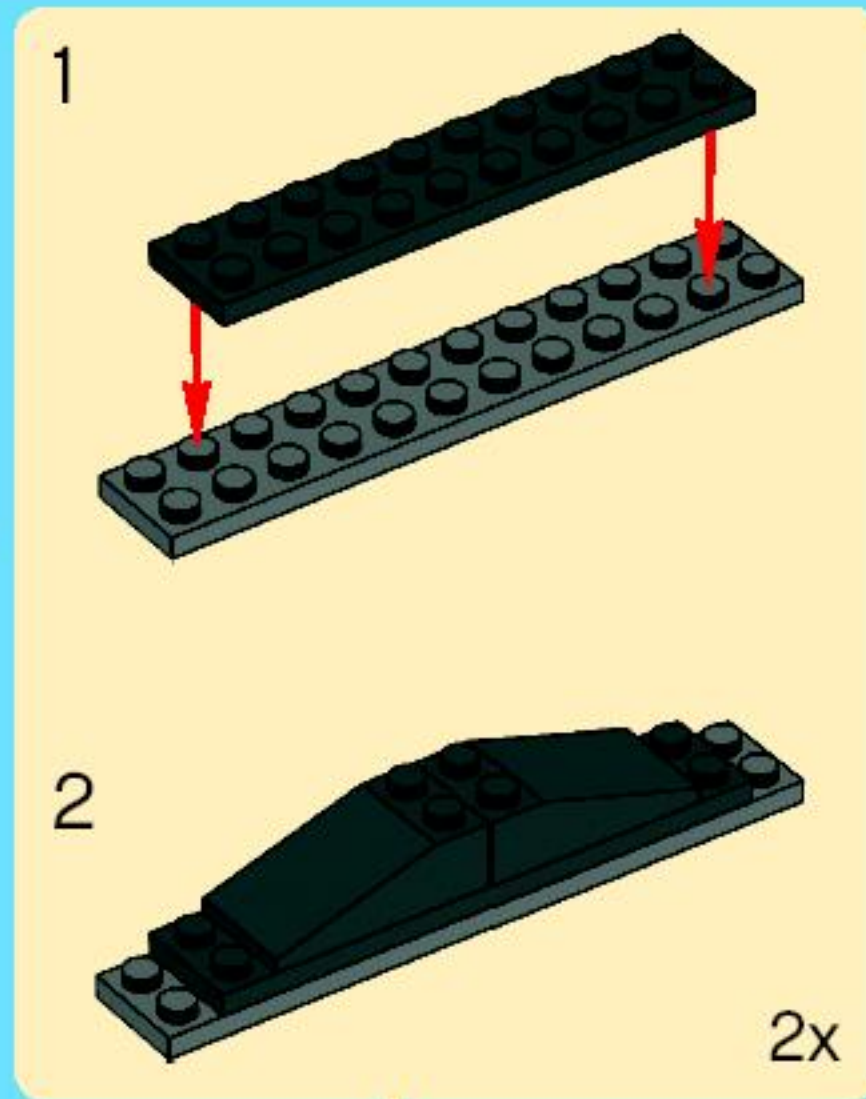



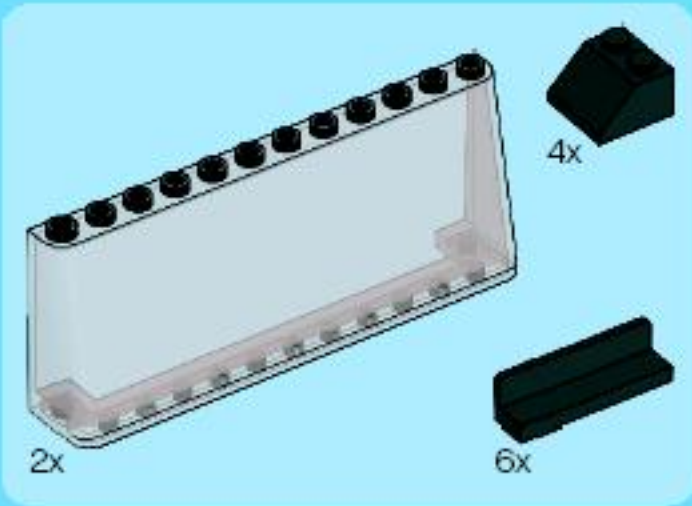

8

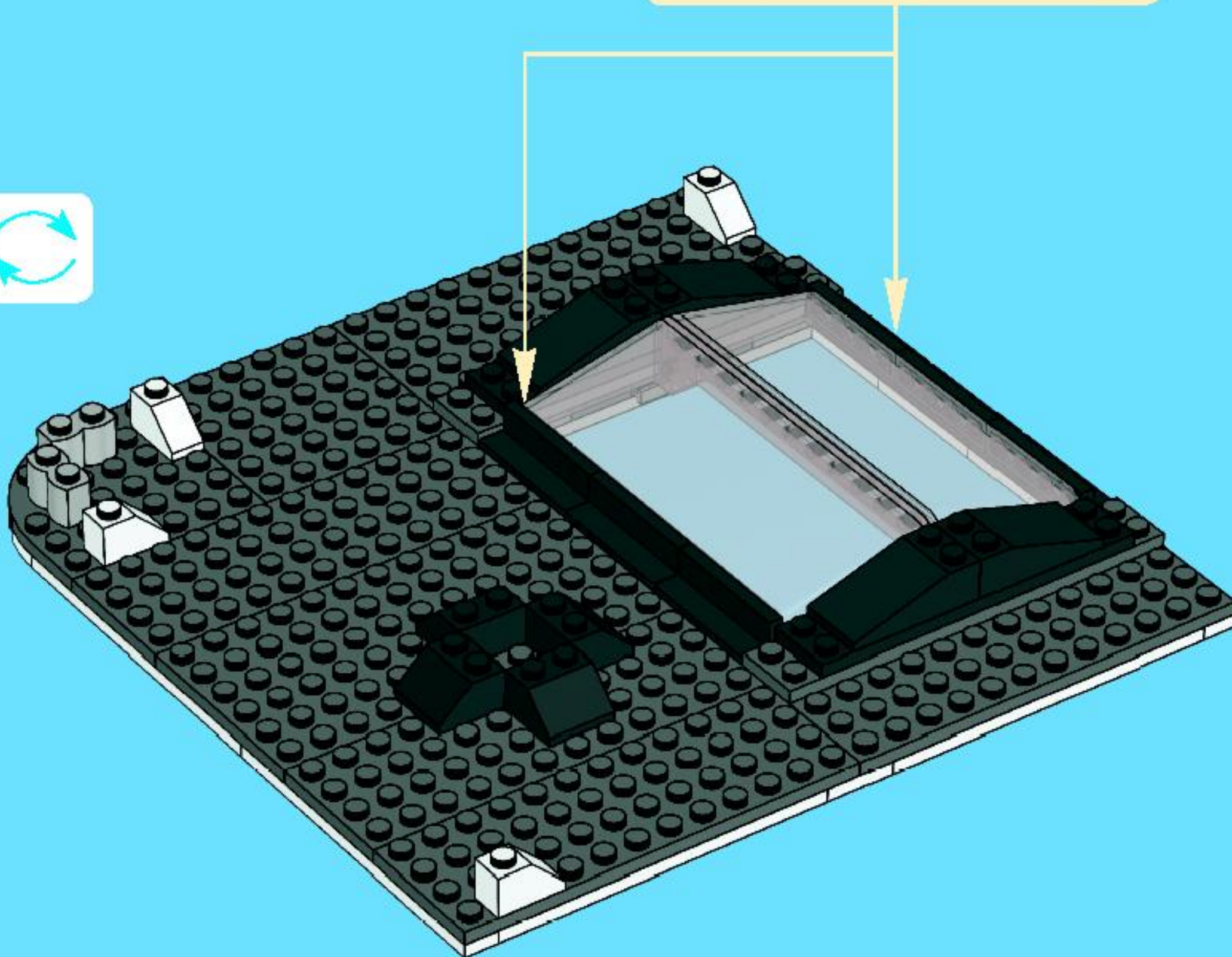
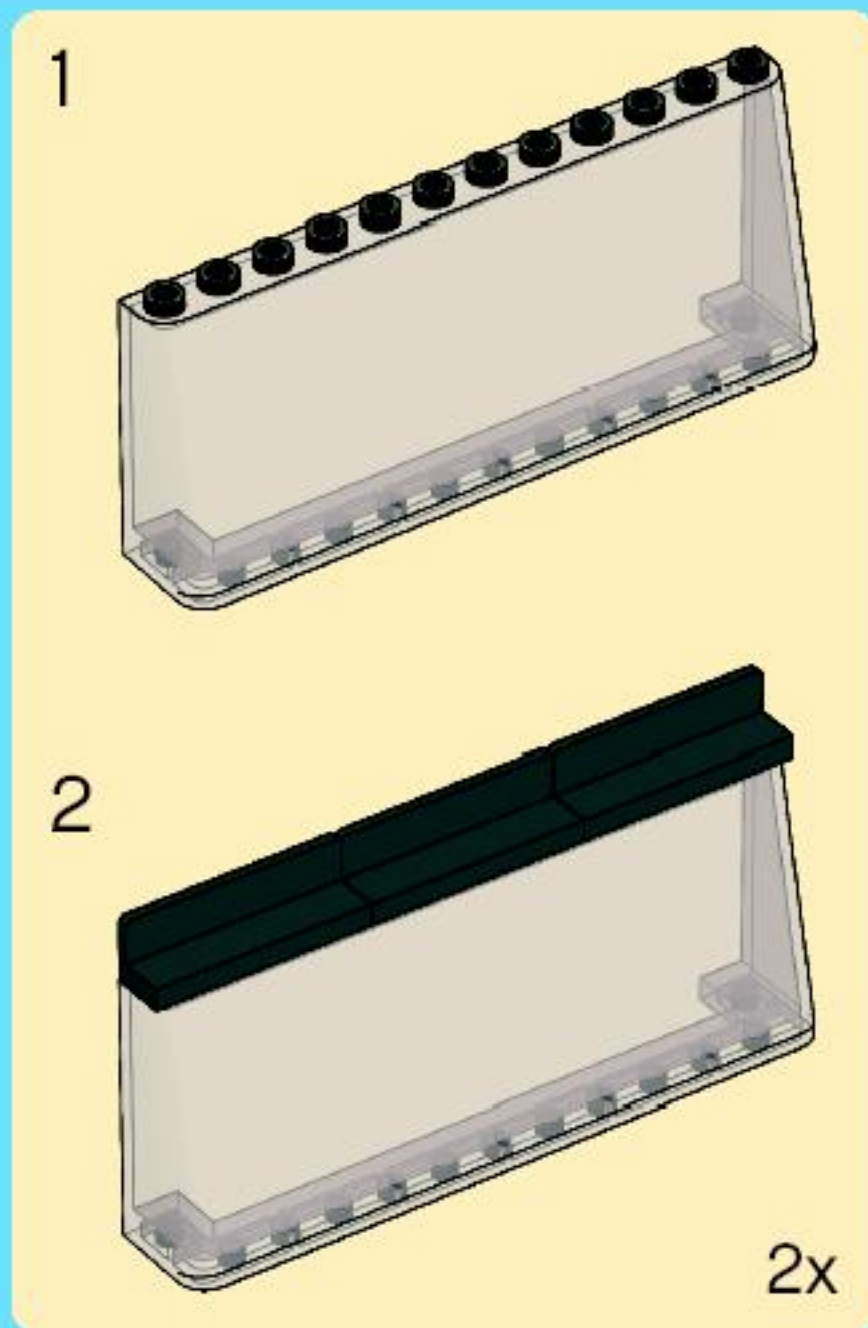



1x



1x



20x



4x

9

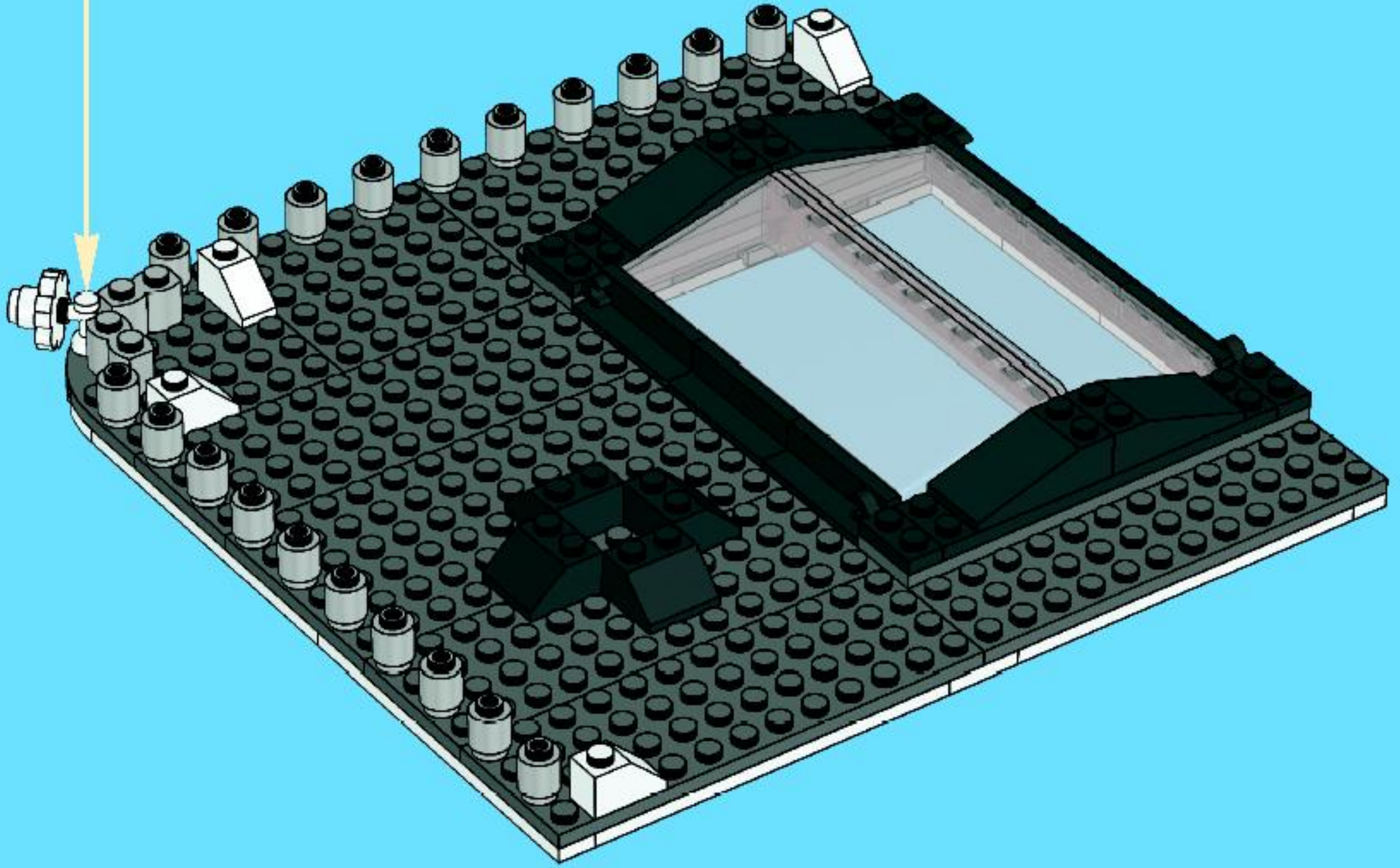
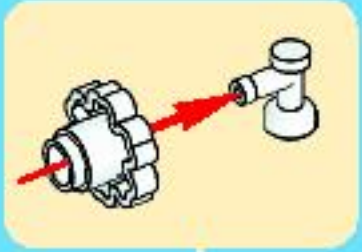



10

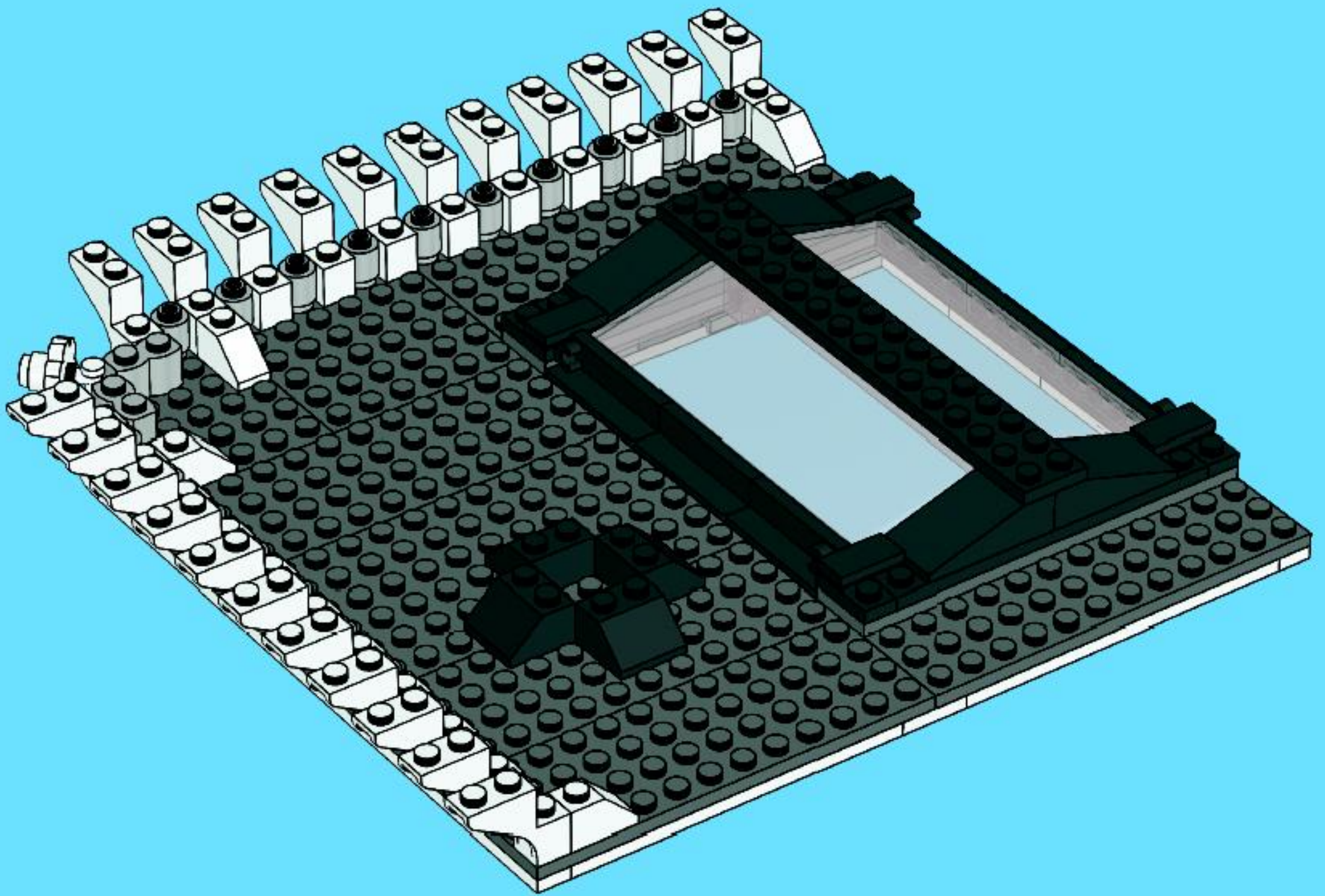



11

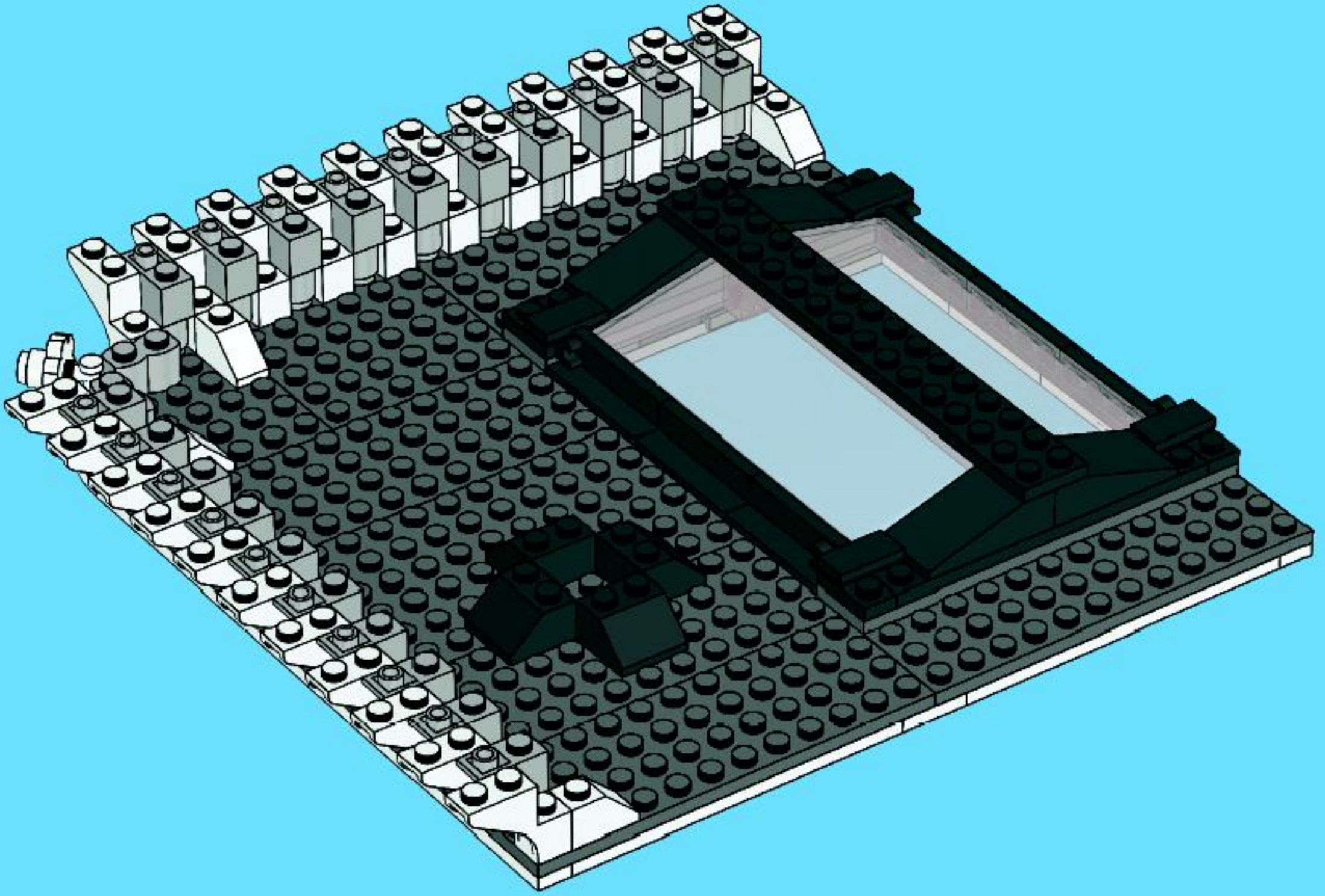



4x



1x

12

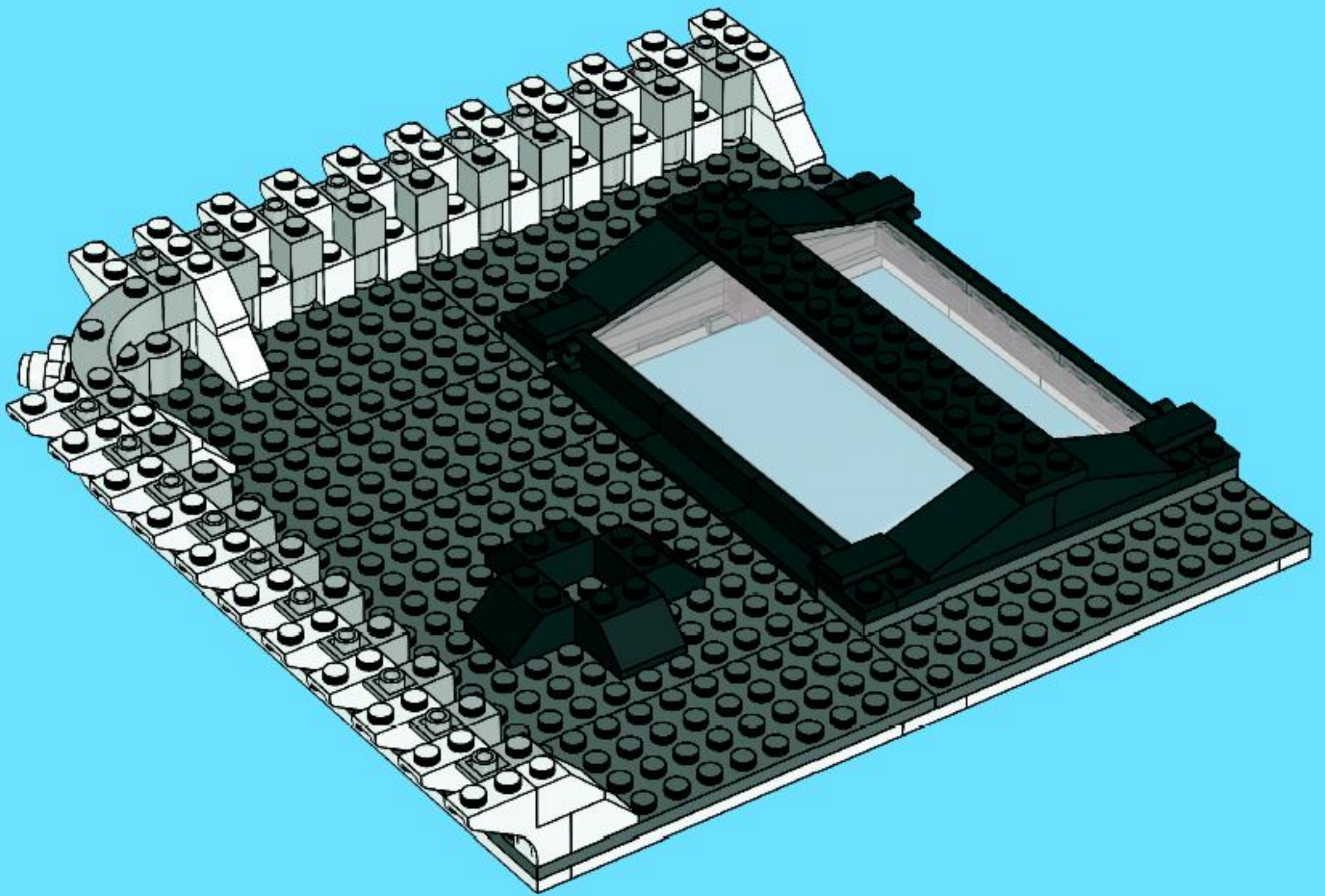



16x

13

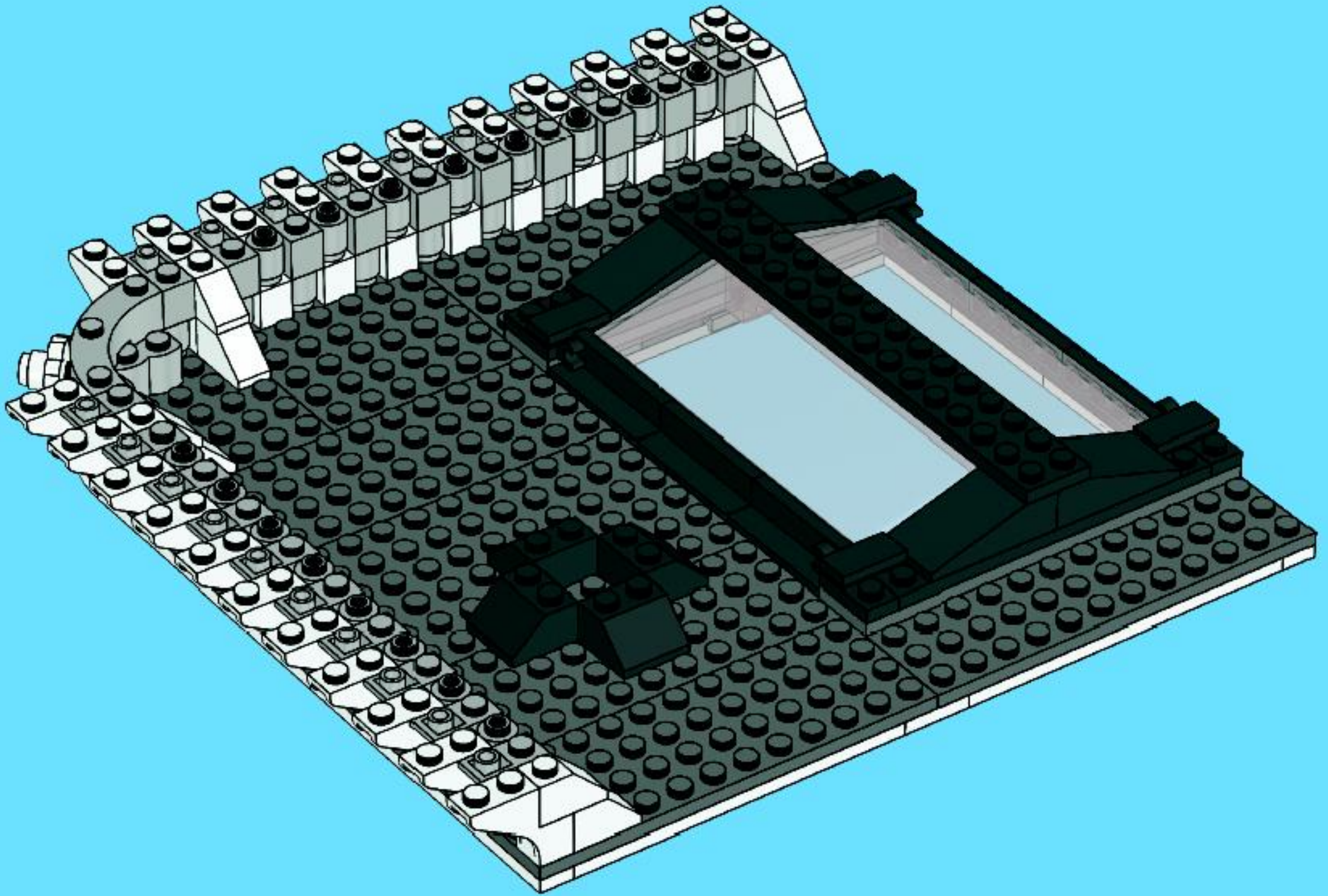

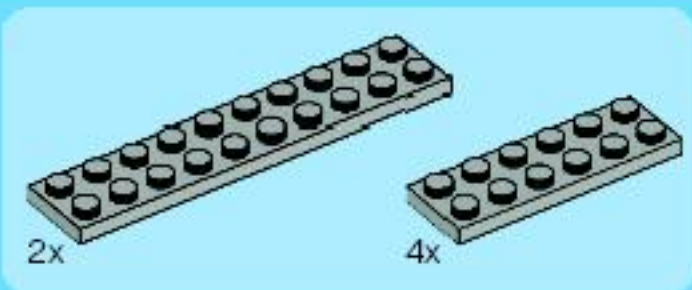

14

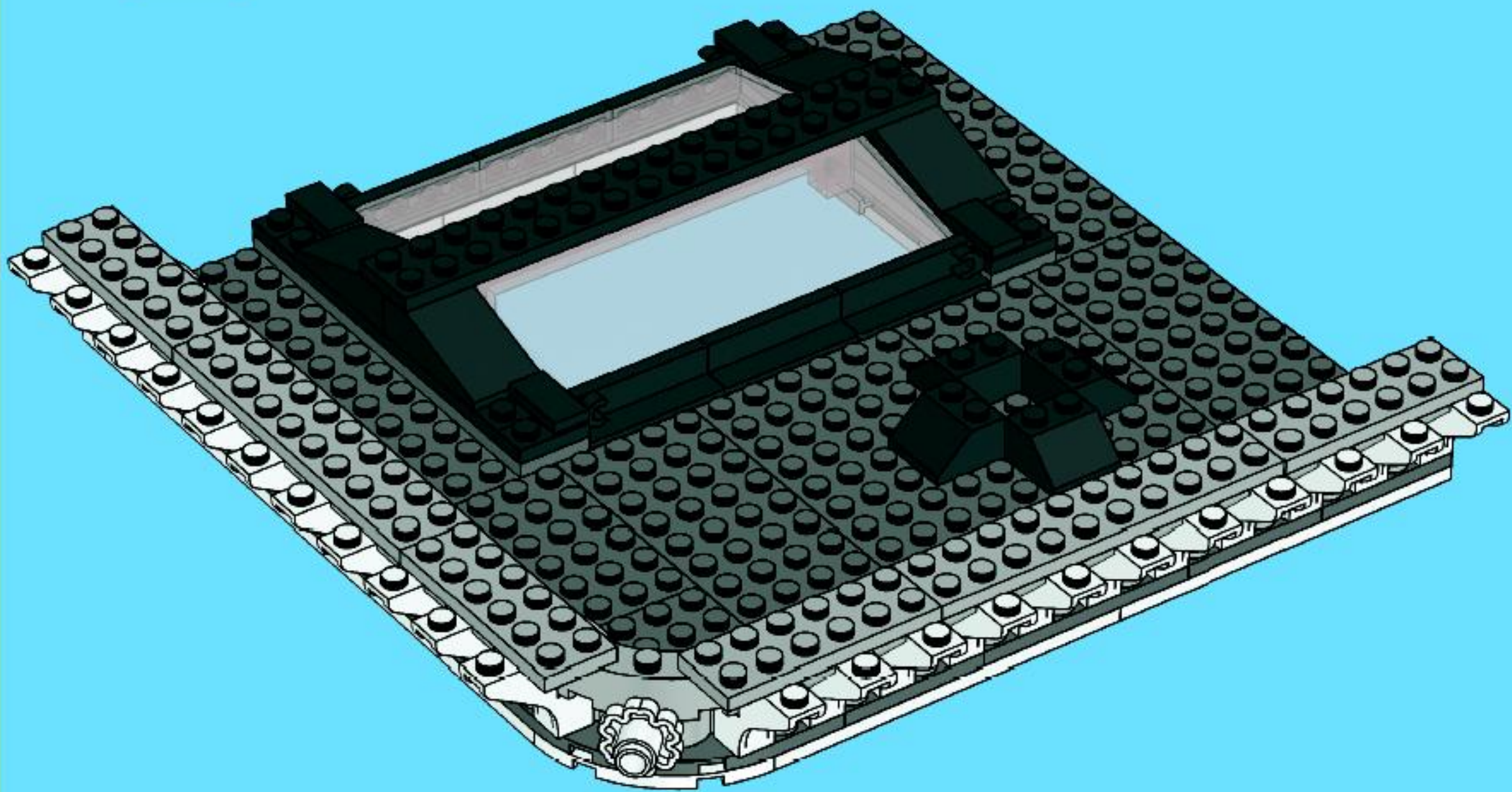

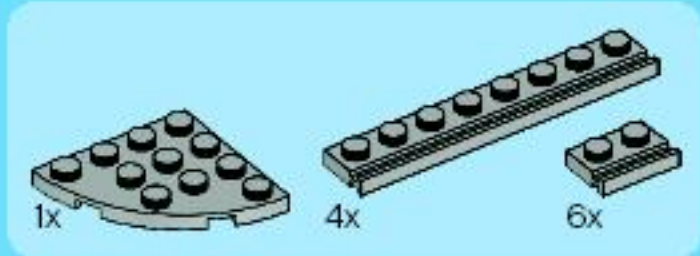

15

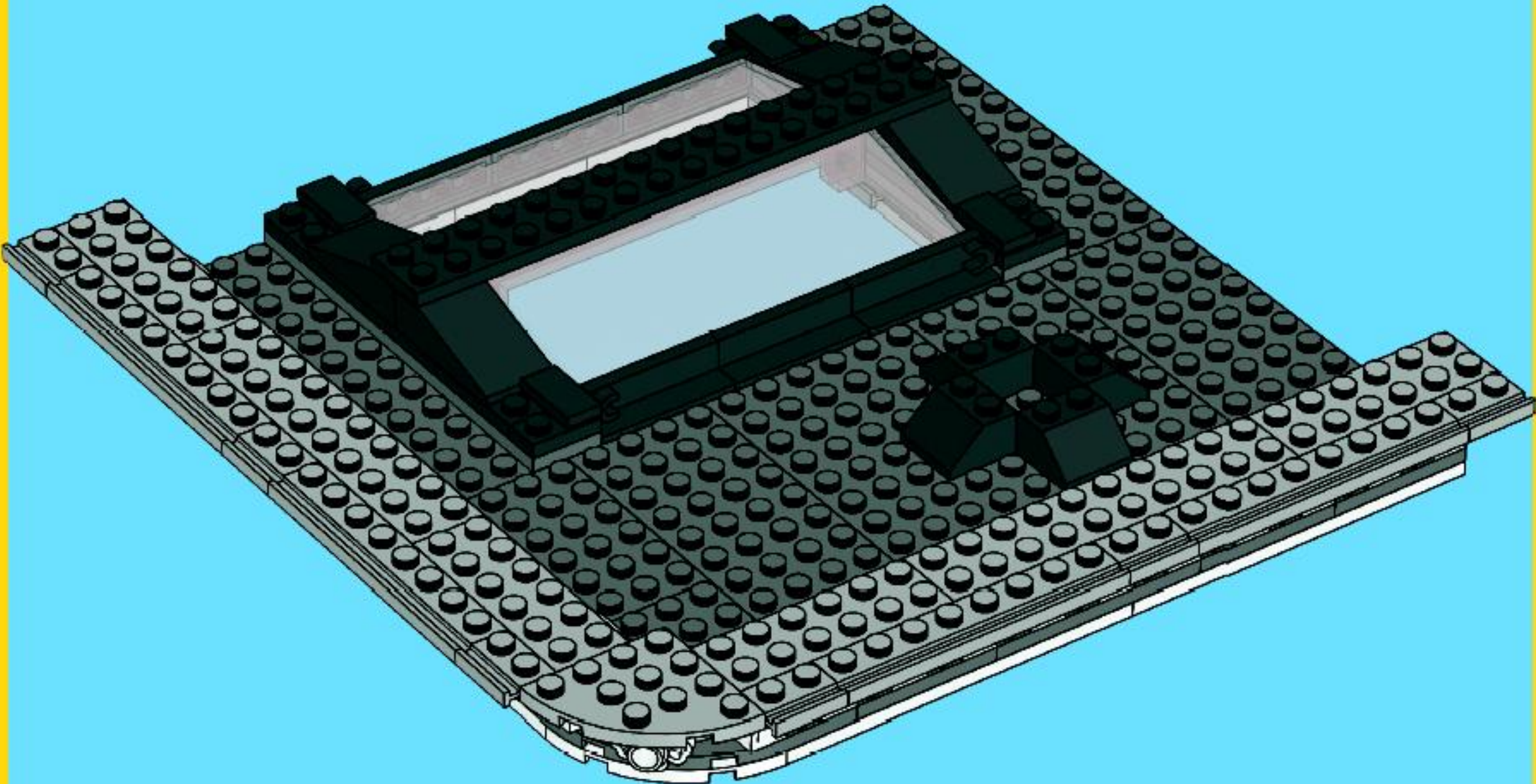



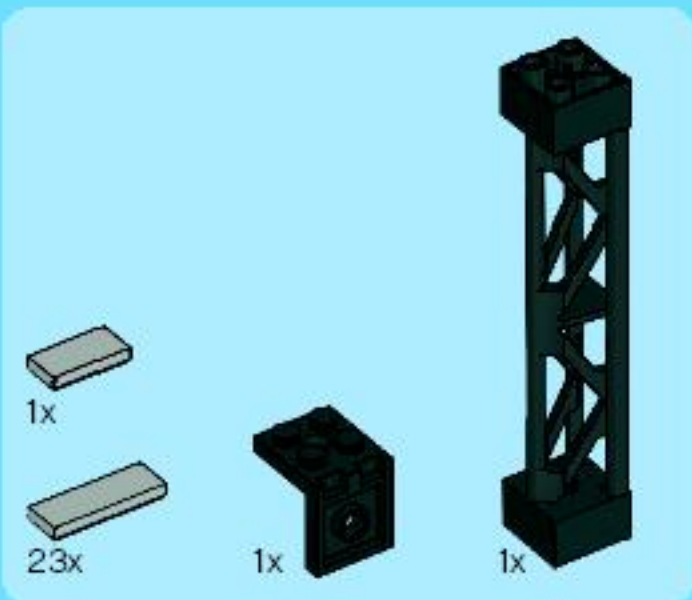

16

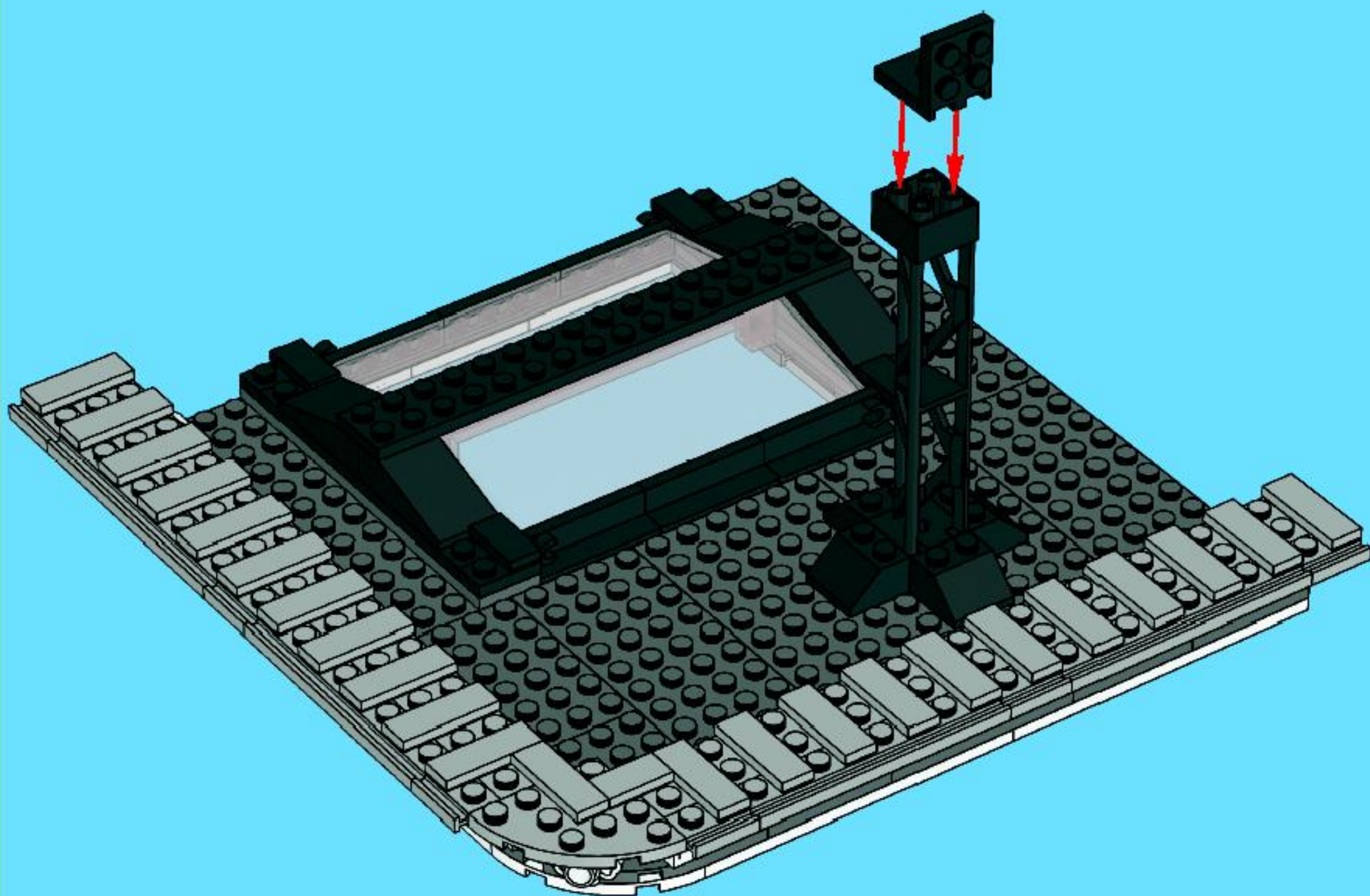

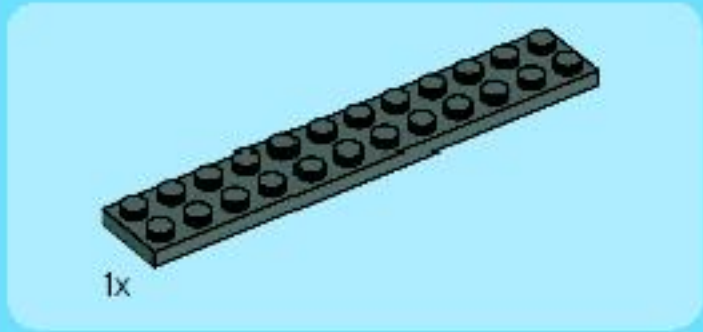
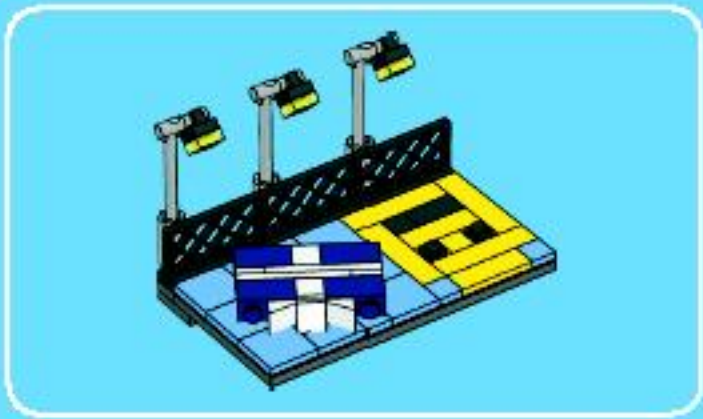

1

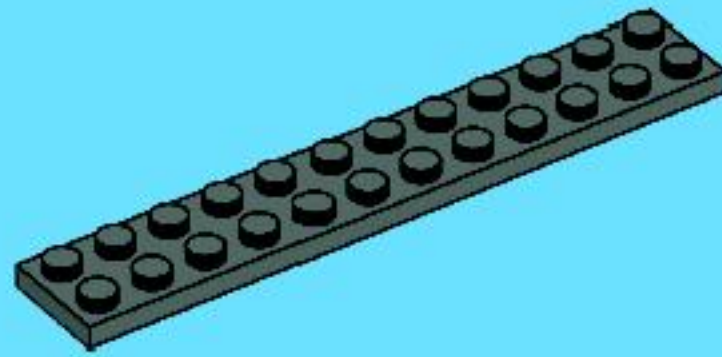

2

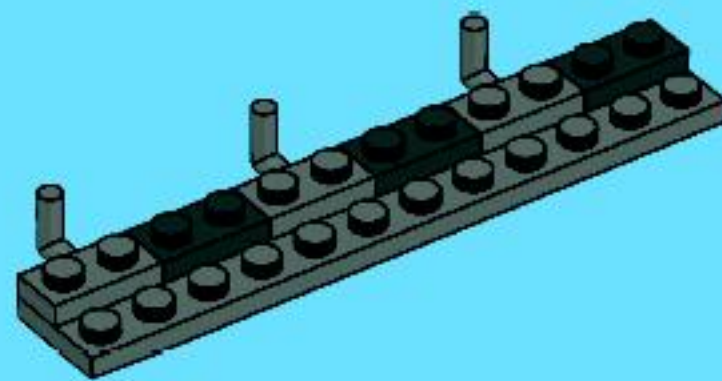



3x

3

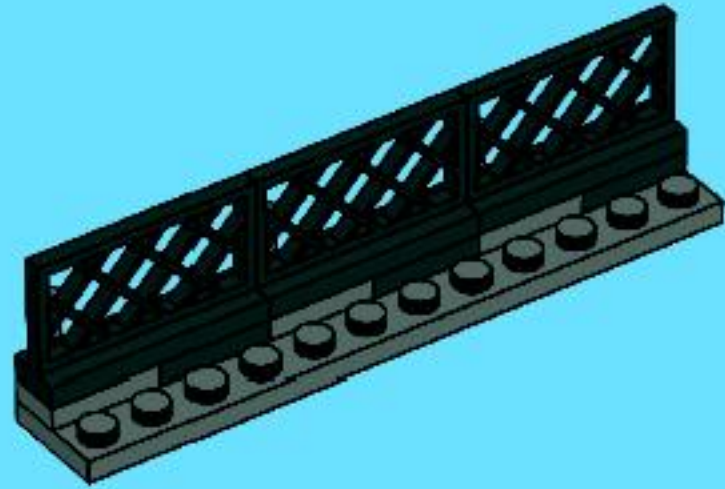

3x



3x



3x



3x

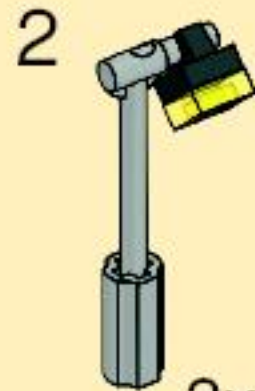
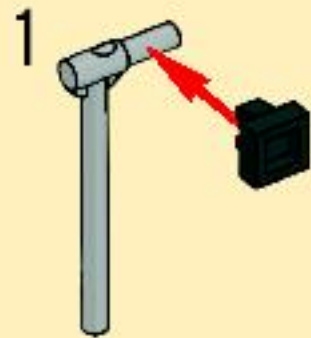

3x

4

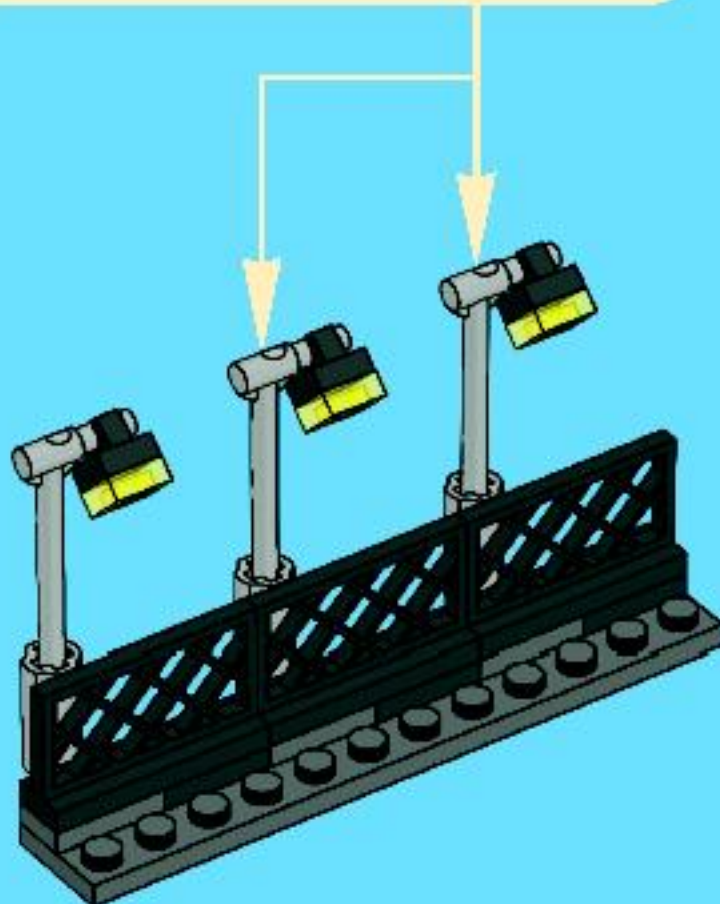

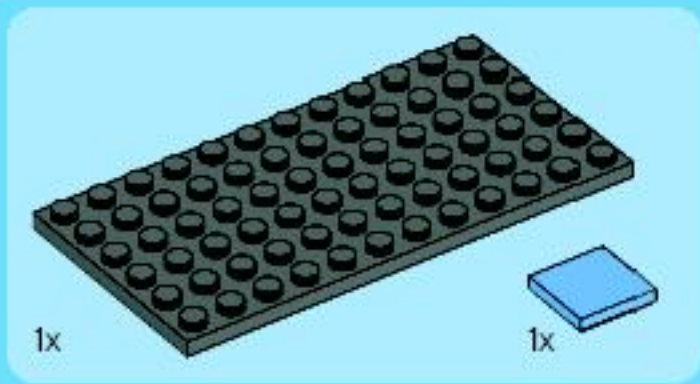

1

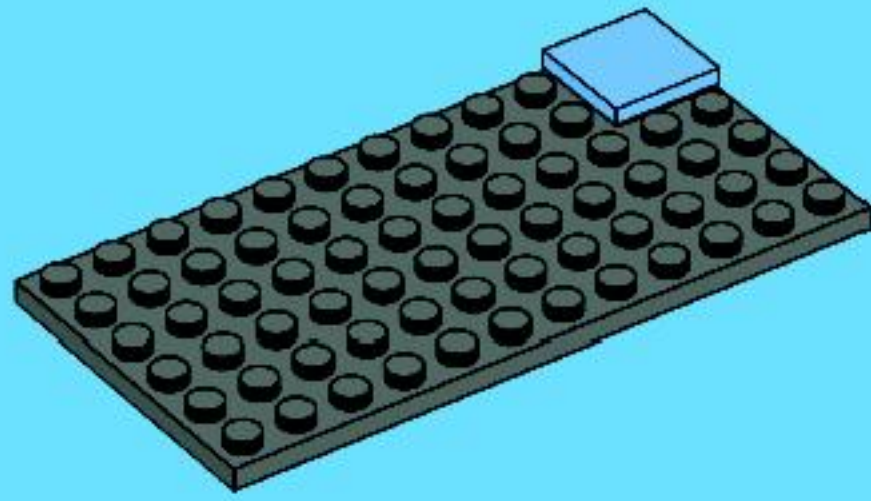

2

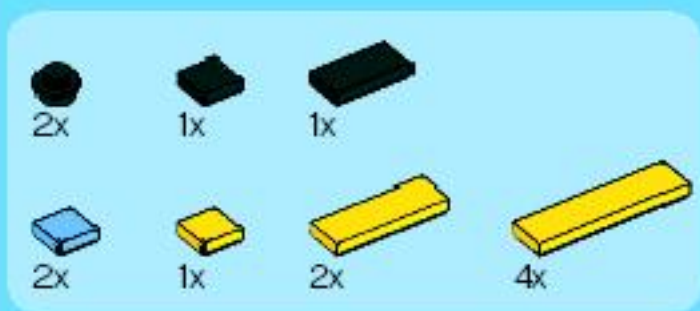
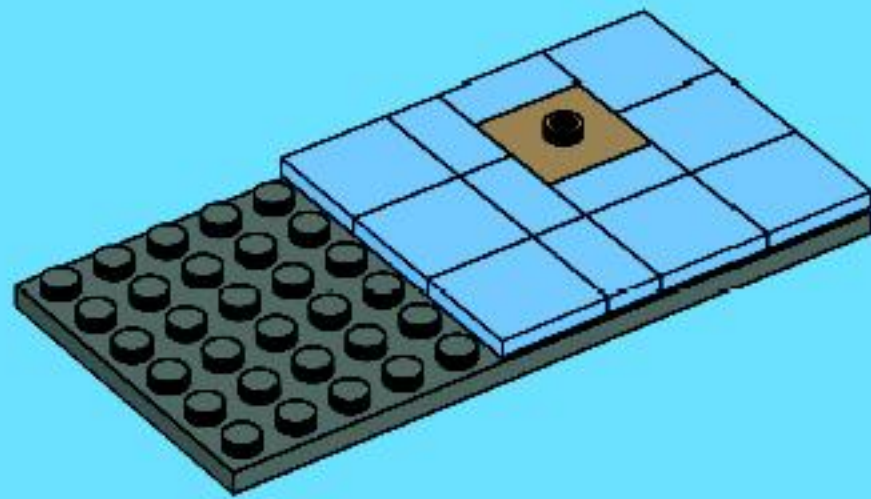

3

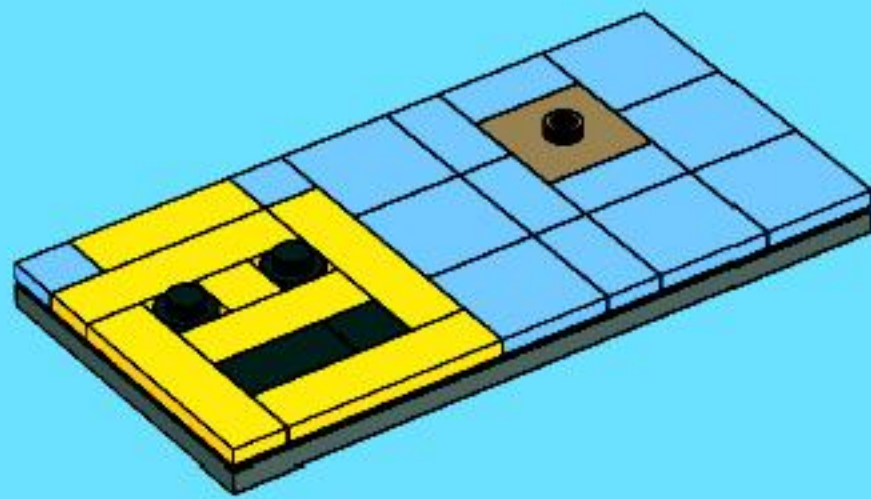

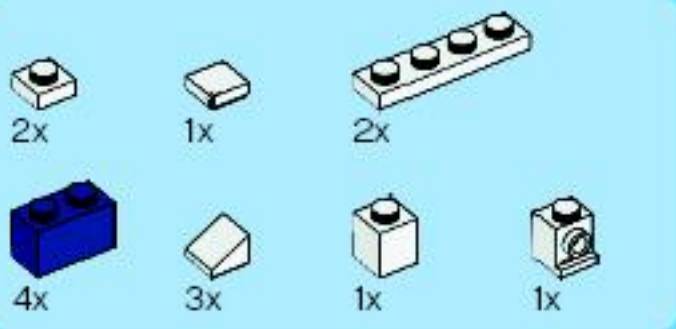

4

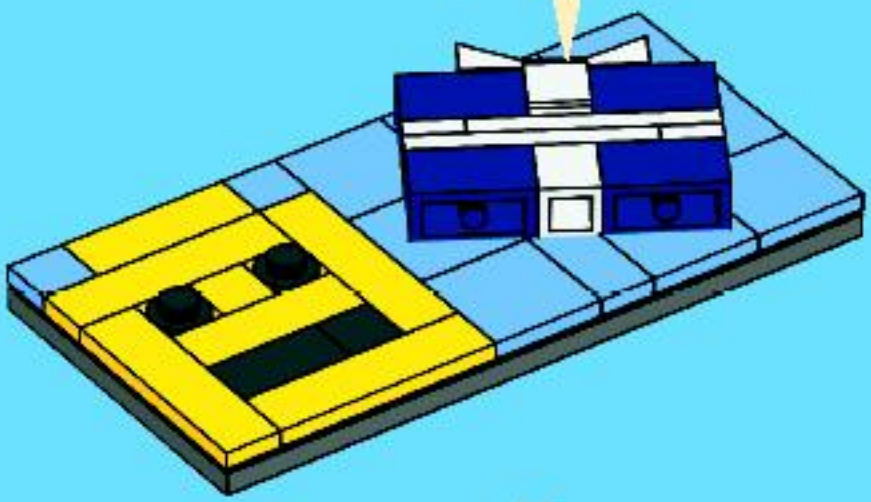
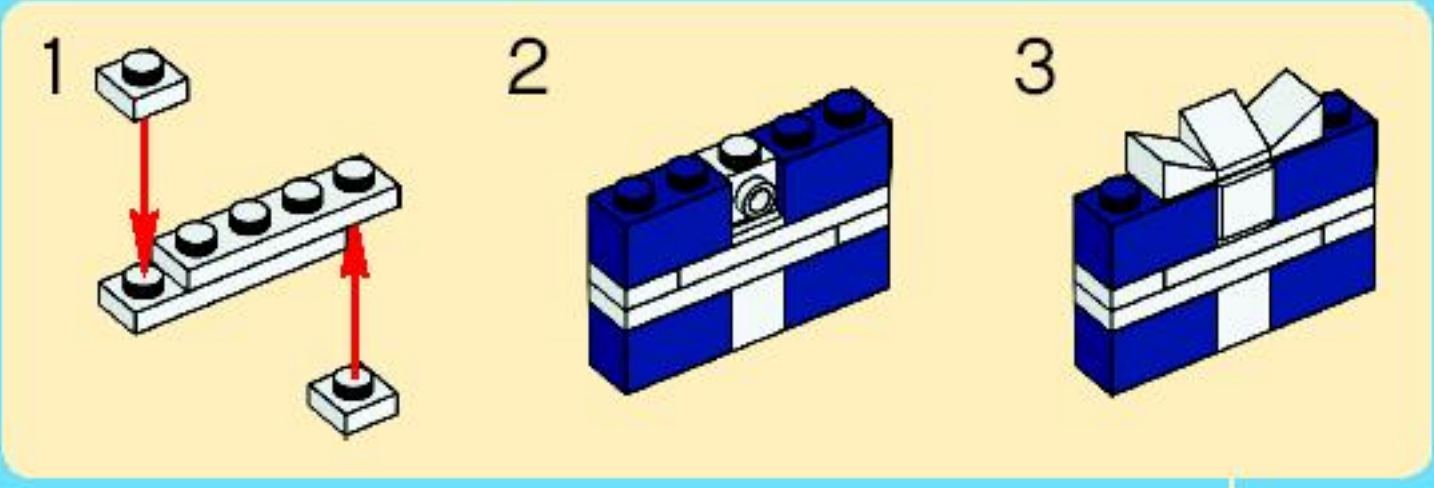

5

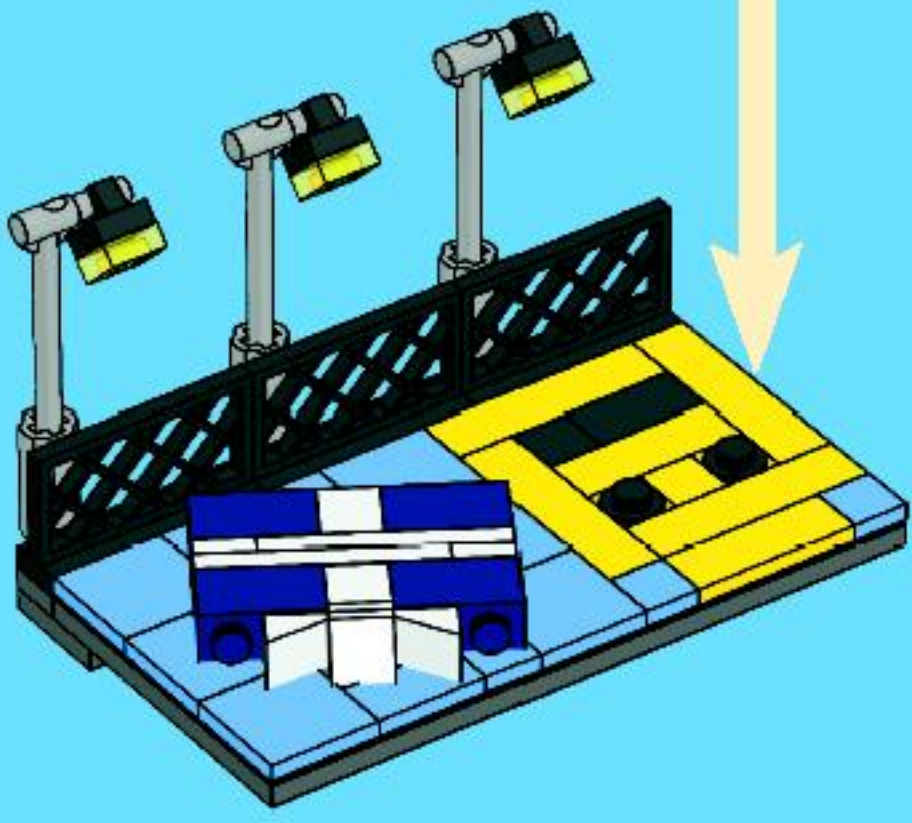

17

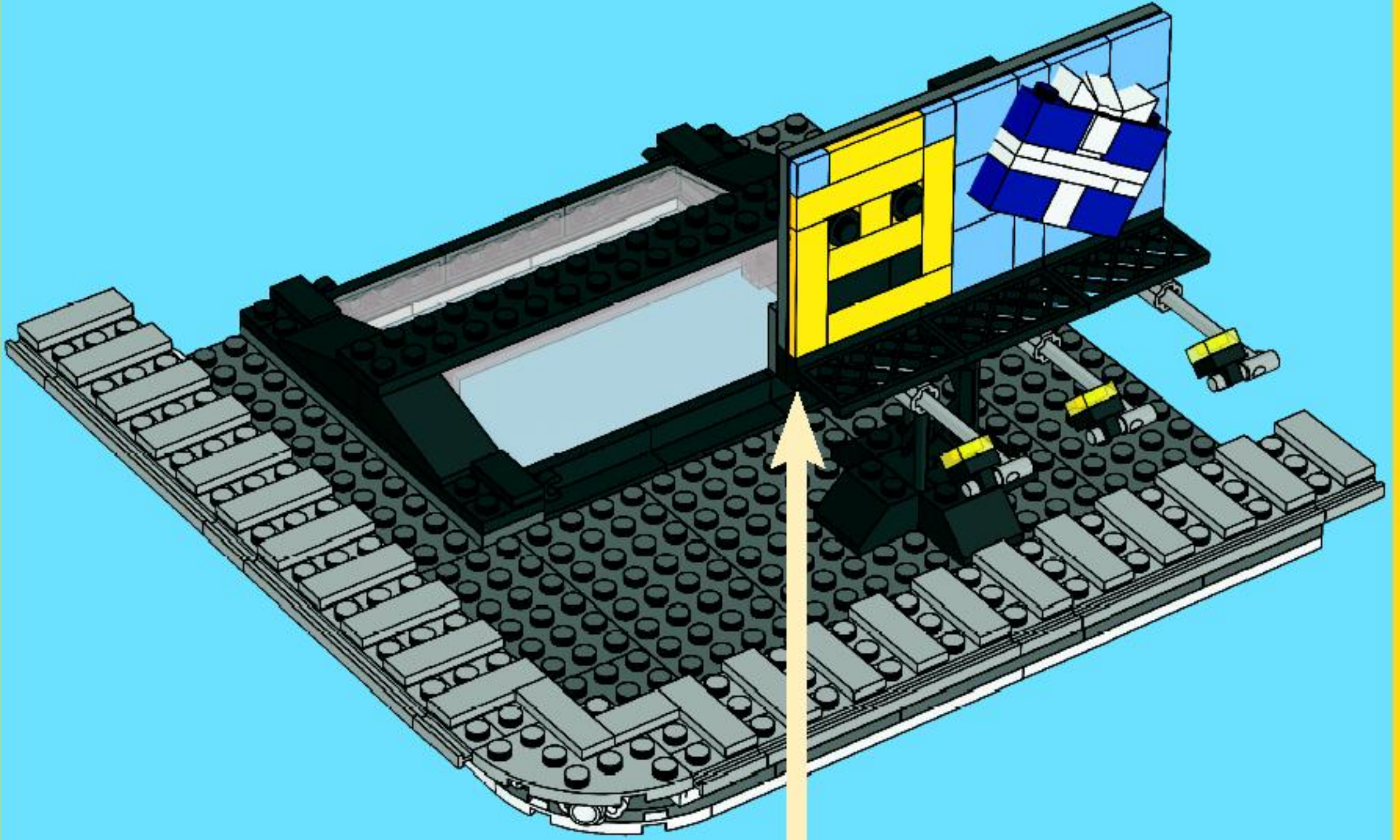

31

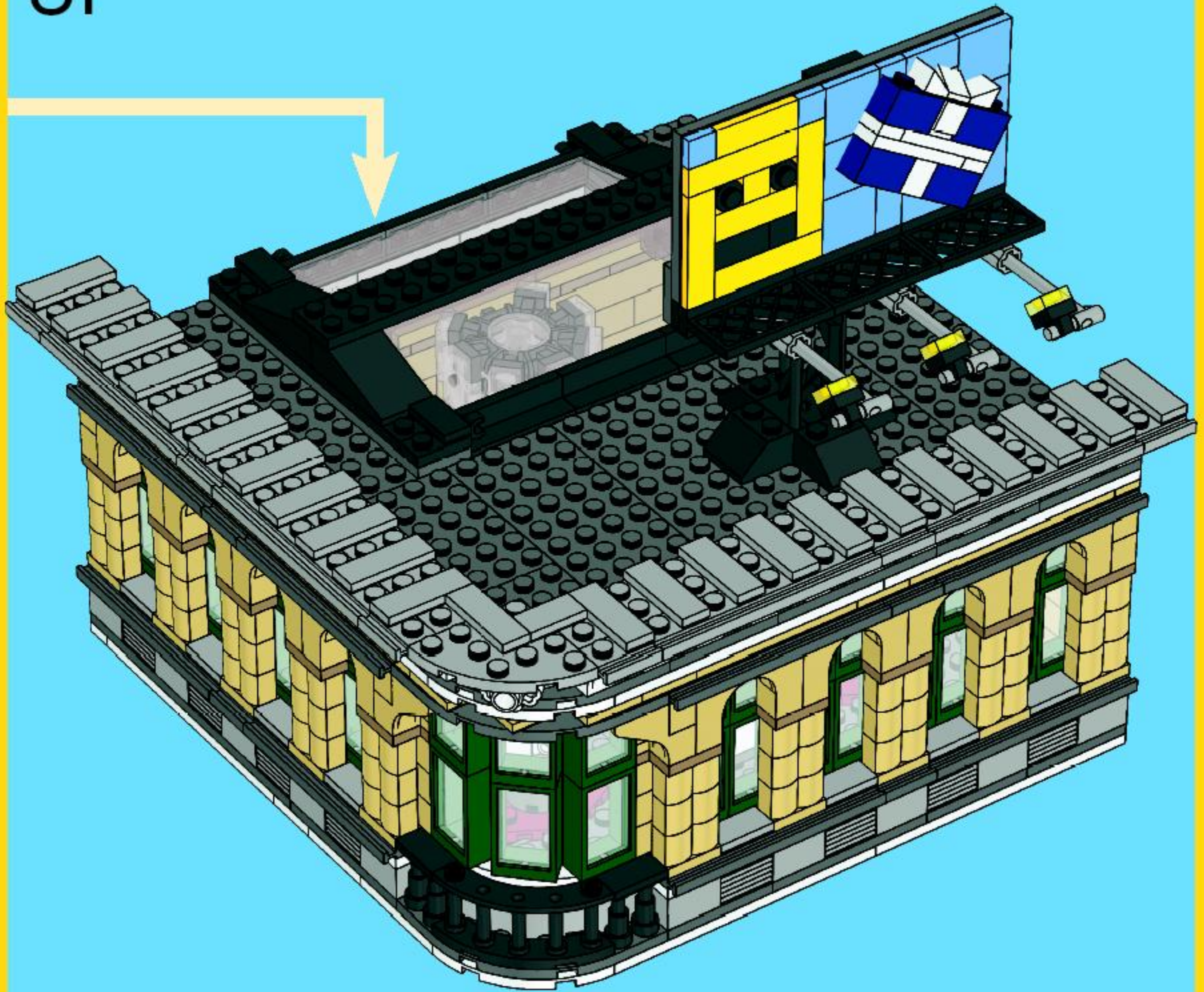

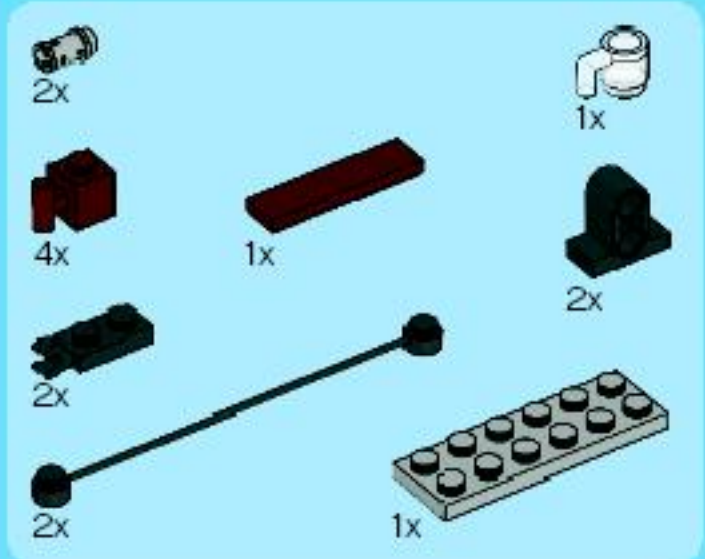

# 32

1

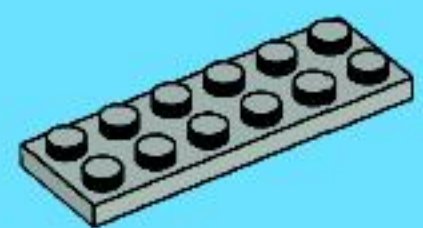

2

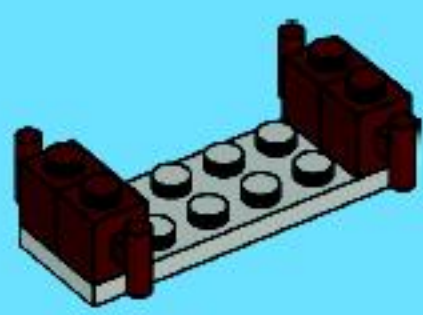

3

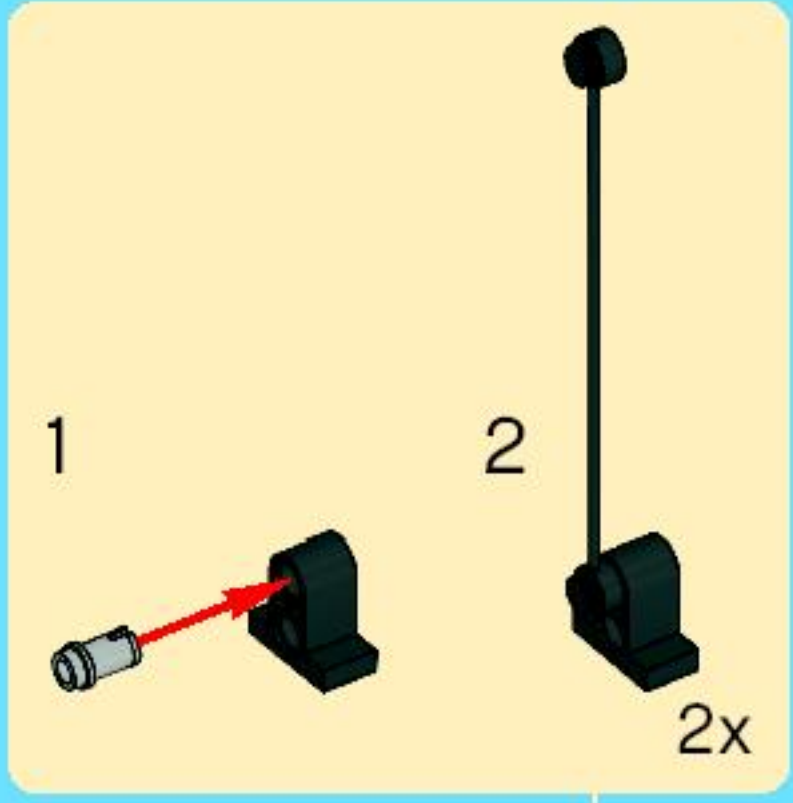

4

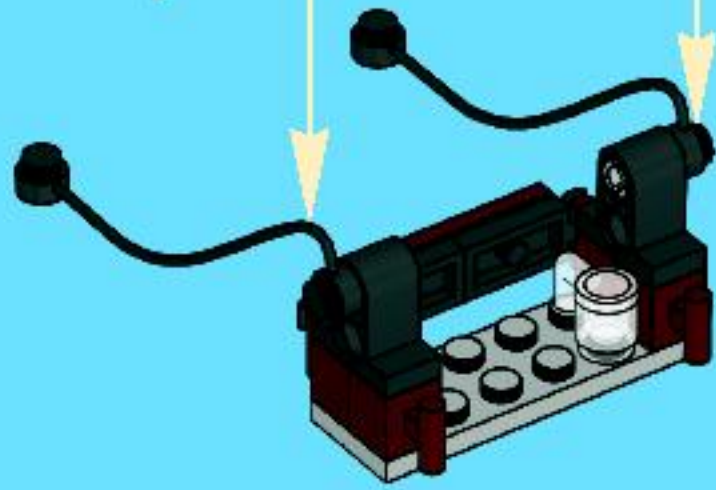

5





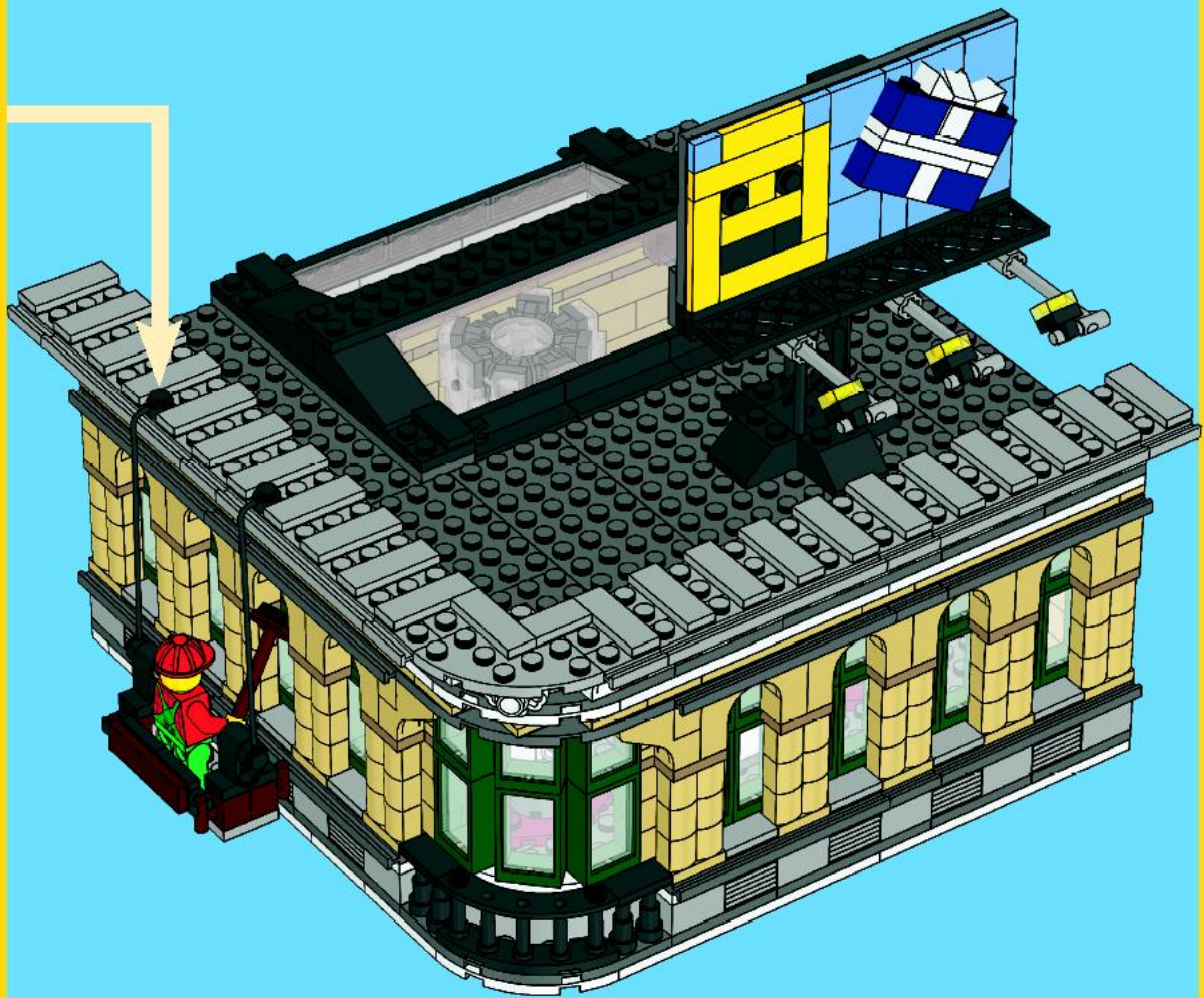



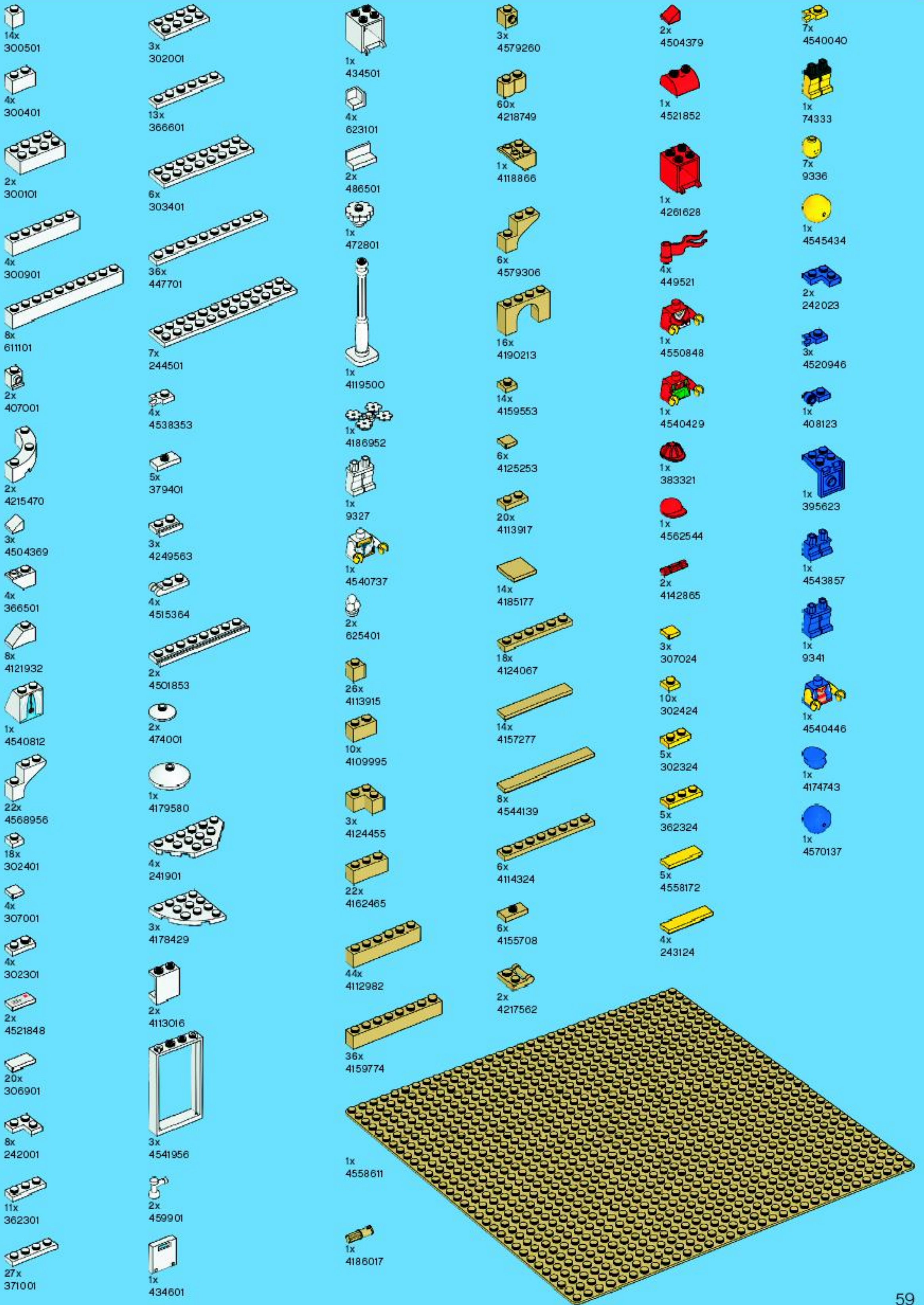

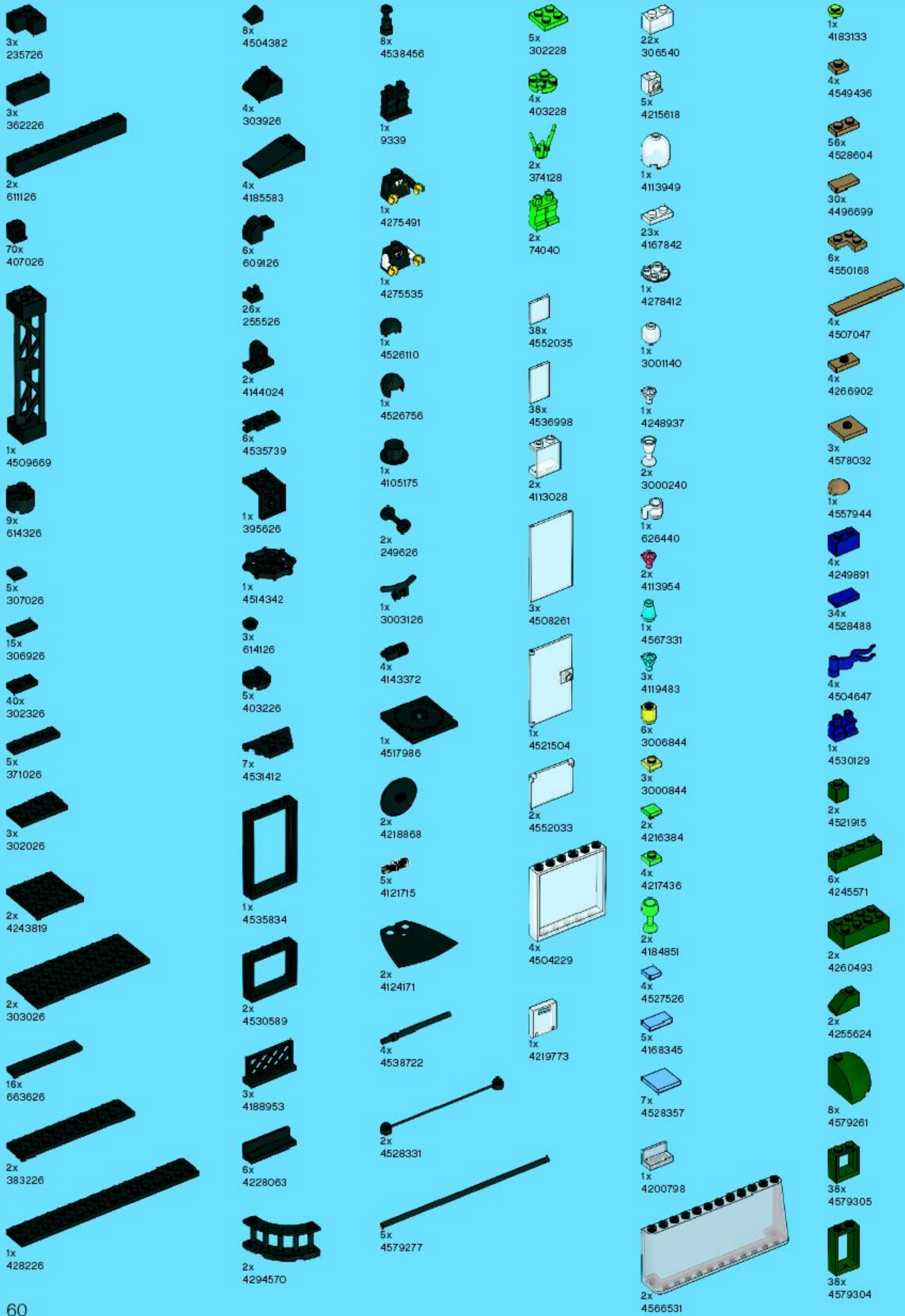

4x 4225823  
 4x 4211252  
 1x 4211194  
 3x 4211159  
 2x 4520638  
 1x 4550736  
 1x 4211157  
 2x 4504277  
 11x 4211389  
 11x 4211388  
 2x 4550325  
 16x 4211387  
 9x 4211349  
 15x 4211428  
 8x 4211394  
 19x 4211393  
 12x 4211392  
 2x 4211390

32x 4211383  
 4x 4258455  
 3x 4215472  
 36x 4211412  
 18x 4521921  
 16x 4568637  
 20x 4211437  
 2x 4211436  
 64x 4211519  
 2x 4519930  
 6x 4211415  
 6x 4211398  
 30x 4211414  
 4x 4211397  
 7x 4211413  
 4x 4211353  
 32x 4558169  
 2x 4277927

6x 4211568  
 3x 4211429  
 3x 4211395  
 33x 4211549  
 2x 4211438  
 12x 4211452  
 7x 4211462  
 4x 4211498  
 1x 4262978  
 1x 4515351  
 1x 4579294  
 1x 4221775  
 3x 4565433  
 2x 4211473  
 1x 4494222  
 2x 4211483  
 1x 4211375  
 3x 4512360  
 4x 4526985  
 1x 4514192

6x 4550169  
 4x 4539114  
 11x 4541544  
 2x 4211053  
 4x 4211056  
 4x 4210998  
 16x 4210967  
 2x 4211008  
 3x 4211134  
 6x 4211067  
 12x 4210706  
 7x 4256149  
 5x 4500517  
 1x 4547222  
 2x 4558955  
 4x 4210848  
 36x 4211052

34x 4211055  
 2x 4211094  
 4x 4211133  
 2x 4211043  
 3x 4260885  
 4x 4210726  
 16x 4210631  
 10x 4543086  
 1x 4570666  
 1x 4210469  
 1x 4216375  
 1x 4490082  
 10x 4523159  
 2x 4505990  
 2x 4287800  
 1x 4527065  
 10x 4249040

Customer Service  
 Kundenservice  
 Service Consommateurs  
 Servicio Al Consumidor

[www.lego.com/service](http://www.lego.com/service) or dial

 : 00800 5346 5555  
 : 1-800-422-5346



10185

10197

10211

**FREE! GRATIS! GRATUIT!**



**club**  
MAGAZINE™

**www.LEGOclub.com**



**00800 5346 5555\***



**1-866-534-6258 • 1-877-518-5346**

US & Canada only

Canada seulement

\* FreePhone. Mobile charges may apply. \*\* Numéros sans Frais. Les Frais peuvent s'appliquer avec les téléphones cellulaires. \*\*\* Gebührenfrei. Kosten für Anrufe aus Mobilfunknetzen können anfallen. \*\*\*\* Gratiskaldetallnummerynúmeri. \*\*\*\*\* Inzeriellgratiskaldetallnummerynúmeri. \*\* Det är gratis, när du ringer Primes Postcode Box. \*\*\* Det är gratis, när du ringer Primes Postcode Box.



**VISIT THE WORLD'S  
BIGGEST LEGO® SHOP!**

**www.LEGOshop.com**



# WIN!

Go to [www.nielsen.com/LEGO](http://www.nielsen.com/LEGO) to fill out a survey for a chance to win a cool LEGO® Product. No purchase necessary. Open to all residents where not prohibited.



## [www.nielsen.com/LEGO](http://www.nielsen.com/LEGO)

### GEWINNE!

Nimm an der Umfrage auf [www.nielsen.com/LEGO](http://www.nielsen.com/LEGO) teil und hab die Chance ein cooles LEGO® Produkt zu gewinnen!  
Die Teilnahme am Gewinnspiel führt zu keinerlei Kaufverpflichtungen. Teilnahme in allen nicht ausgeschlossenen Ländern möglich.

### WIN!

Ga naar [www.nielsen.com/LEGO](http://www.nielsen.com/LEGO), vul een enquêteformulier in en maak kans op een cool LEGO® product.  
Geen aankoopverplichting. Iedereen mag deelnemen. Uitgezonderd ingezetenden van landen waar een enquêteverbod geldt.

### GAGNE!

Visite [www.nielsen.com/LEGO](http://www.nielsen.com/LEGO) pour répondre à un questionnaire et avoir une chance de gagner un produit LEGO® très cool!  
Aucune obligation d'achat. Ouvert à tous les résidents des pays autorisés.

### 当てよう!

[www.nielsen.com/LEGO](http://www.nielsen.com/LEGO)にアクセスして、アンケートにご記入ください。当選者にはレゴ製品を差し上げます。  
お買い上げの必要はありません。競止されていない限り、すべての皆様にご利用いただけます。