

---

# LE TITANIC

LIVRET 1

→ Une carte postale de la White Star Line montrant le *Titanic*.

---

# LE ROI DES OCÉANS

Lorsque le RMS *Titanic* quitte le port de Southampton en Angleterre, le 10 avril 1912, pour son voyage inaugural à destination de New York, il est non seulement le plus grand navire à flot de l'époque, mais aussi le plus luxueux. C'est le second d'une série de trois paquebots ultramodernes de la classe Olympic commandés par la White Star Line dans le but de permettre à l'entreprise de conserver sa position dominante sur la ligne transatlantique, très concurrentielle. Les constructeurs du chantier naval Harland and Wolff, basé à Belfast, reçoivent l'autorisation de dépenser ce qu'il faut pour procurer au *Titanic* un niveau de confort et de luxe jamais vu auparavant.





↑ Le RMS Titanic au départ de Southamton le 10 avril 1912.

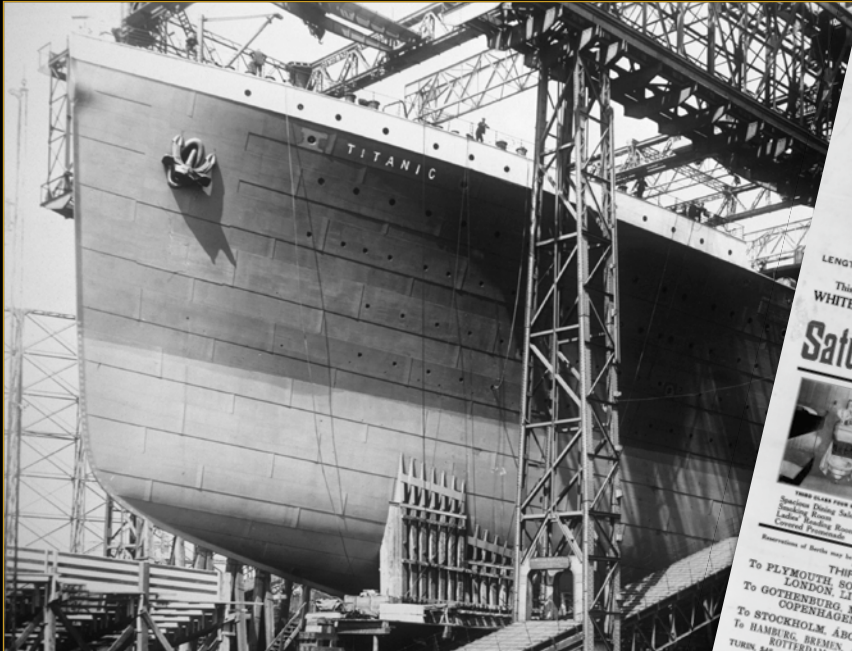

↑ La proue du Titanic lors de sa construction au chantier naval de Harland and Wolff à Belfast, en Irlande.

**WHITE STAR LINE**  
 ROYAL & UNITED STATES MAIL STEAMERS  
 FIRST SAILING OF THE LATEST ADDITION TO THE WHITE STAR FLEET  
 The Queen of the Ocean  
**TITANIC**

LENGTH 682 FT. OVER 45,000 TONS TRIPLE-SCREWS BEAM 92 FT.  
 This, the Latest, Largest and Finest Steamer Afloat, will sail from  
**WHITE STAR LINE, PIER 59 (North River), NEW YORK**

**Saturday, April 20th** At 12 Noon

THIRD CLASS CABIN DECK FROM  
 Smoking Saloon Saloons  
 Ladies' Smoking Room  
 General Promenade

All passengers booked in closed rooms  
 containing 2, 4, or 6 berths, a large room  
 bar equipped with wait-staff, etc.

THIRD CLASS RATES ARE:

To PLYMOUTH SOUTHAMPTON LONDON LIVERPOOL and GLASGOW.	\$36.25
To GOTHENBURG MALMO CHRISTIANIA, COPENHAGEN, ESBJERG, Etc.	41.50
To STOCKHOLM, ABO, HANGO, HELSINGFORS, HAMBURG, BREMEN, ANTWERP, AMSTERDAM, ROTTERDAM, HAVRE, CHERBOURG, NAPLES, BRINDISI, PIRAEUS, ETC.	44.50
DO NOT DELAY. <small>Passage and other charges through the White Star Line Agents in direct from</small> WHITE STAR LINE, 9 Broadway, New York	45.00

**TICKETS FOR SALE HERE**

← 1912 : une publicité pour le paquebot de luxe Titanic, annonçant l'heure du départ du voyage inaugural du navire. Les prix des billets et la description des couchettes y sont indiqués.



→ Le RMS Titanic et le RMS Olympic, deux paquebots de la White Star Line, sont vus ensemble pour la dernière fois le 3 février 1912.

---

# LE PAQUEBOT À TROIS HÉLICES DE LA CLASSE OLYMPIC

Le *Titanic* est propulsé par trois puissants moteurs, chacun actionnant sa propre hélice. Les deux machines à vapeur extérieures mesurent 19 mètres de long, pèsent 720 tonnes et produisent une puissance combinée de 30 000 ch. La turbine centrale à basse pression ajoute 16 000 ch supplémentaires. Il faut 29 chaudières, 484,5 tonnes d'eau et 600 tonnes de charbon par jour pour alimenter les machines à vapeur. Les trois moteurs sont reliés directement aux hélices via de longs conduits. Le diamètre des deux hélices extérieures est impressionnant puisqu'il mesure 7,2 m, tandis que celui de la plus petite au centre est de 5,2 m. Grâce à une telle puissance, le *Titanic* atteint une vitesse de pointe de plus de 23 nœuds (42 km/h).

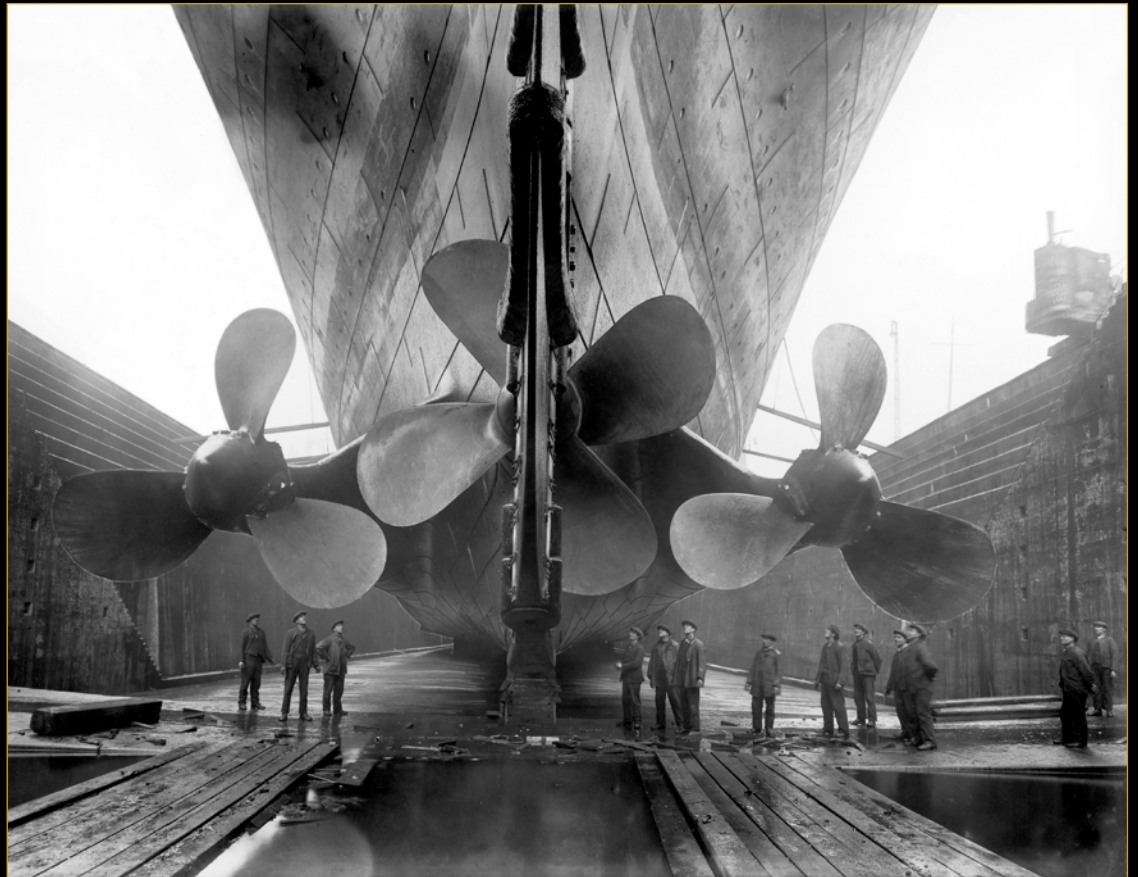

↑ Les énormes hélices du RMS Titanic, alors que le navire est immobilisé en cale sèche.



[LEGO.com/brickseparator](https://LEGO.com/brickseparator)

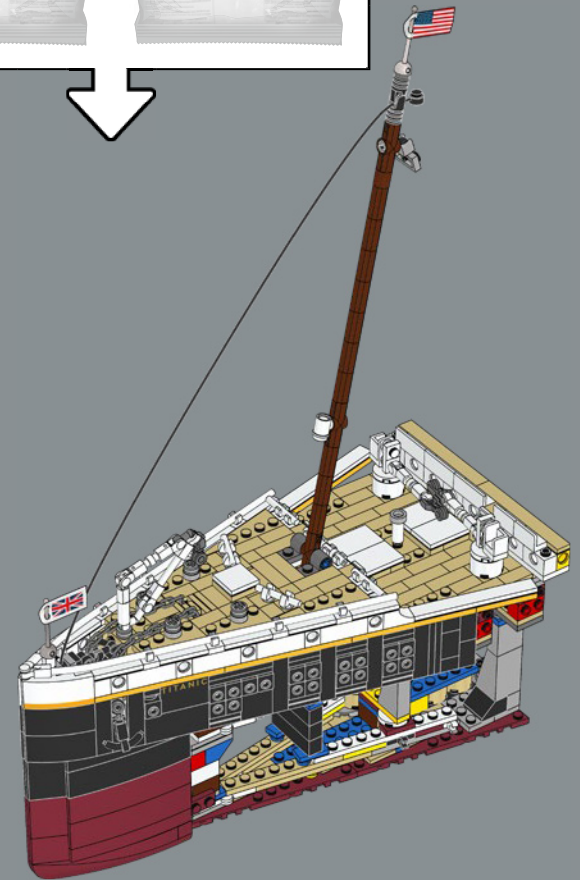
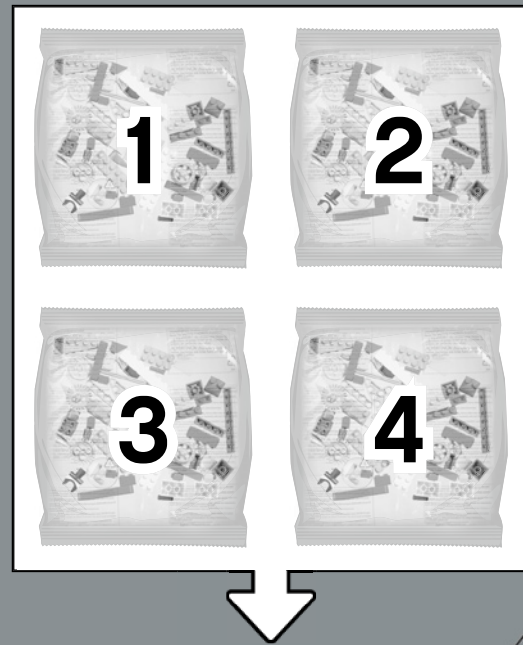

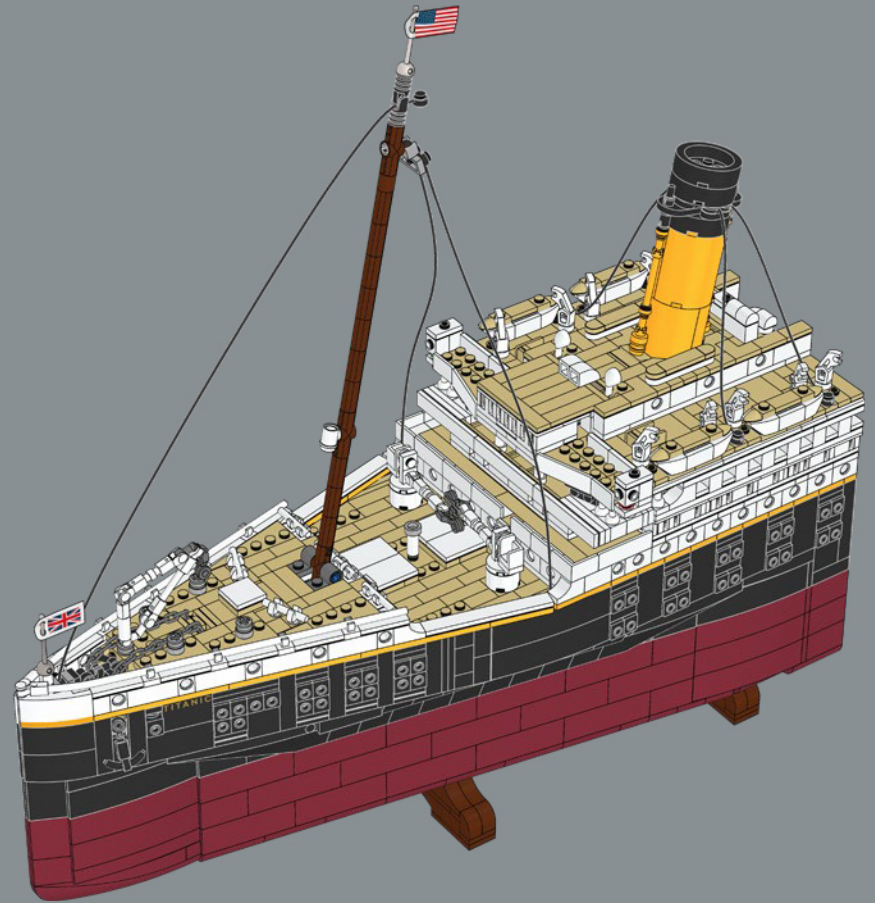
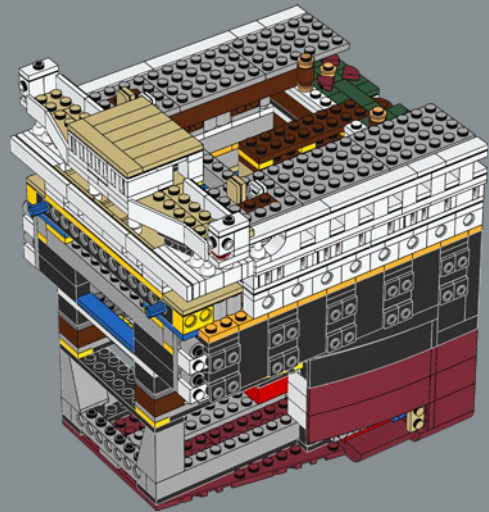

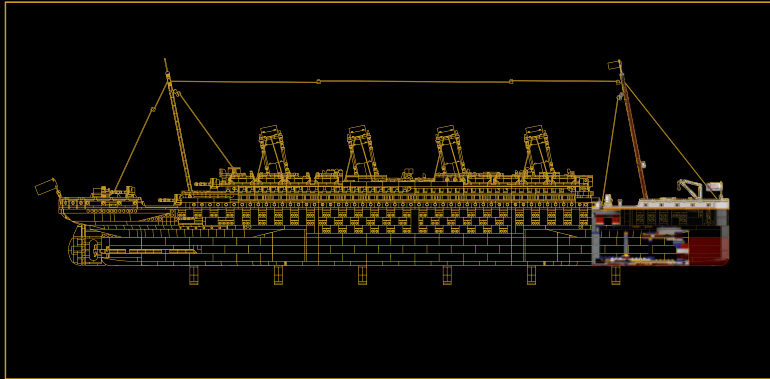

## SECTION 1:

# PROUE ET COFFRE

Dans cette section, vous allez construire la proue du navire avec les ancres, le nom du navire, le coffre, les trappes et grues de chargement, la grue d'ancre avec la 3<sup>e</sup> ancre et le mât avant. À l'intérieur du navire, les structures qui vont supporter la coque avant inclinée vont également être construites. Celles-ci seront raccordées aux supports des sections suivantes pour compléter la coque avant du modèle.

↓ La brique à trois arcs 2x10x2 est utilisée pour former l'avant de la quille du modèle.





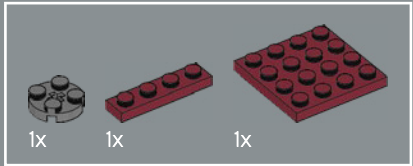
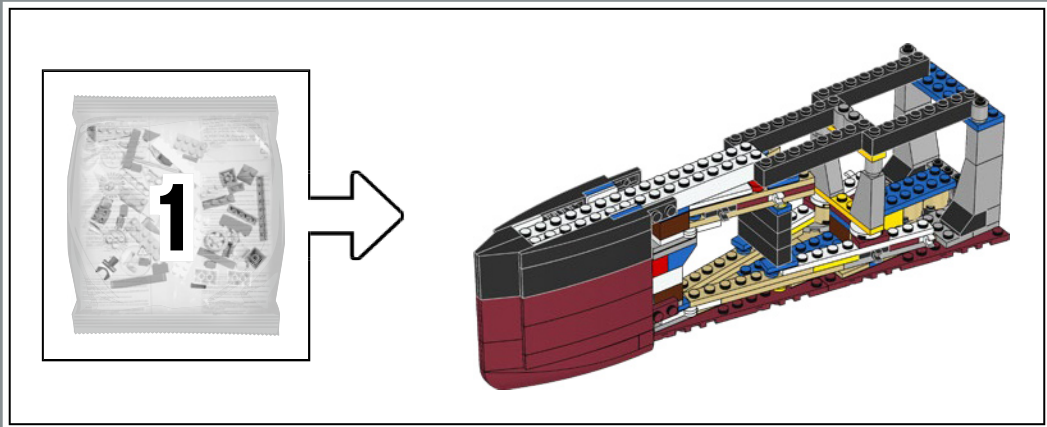

2

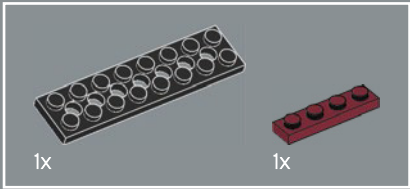

1

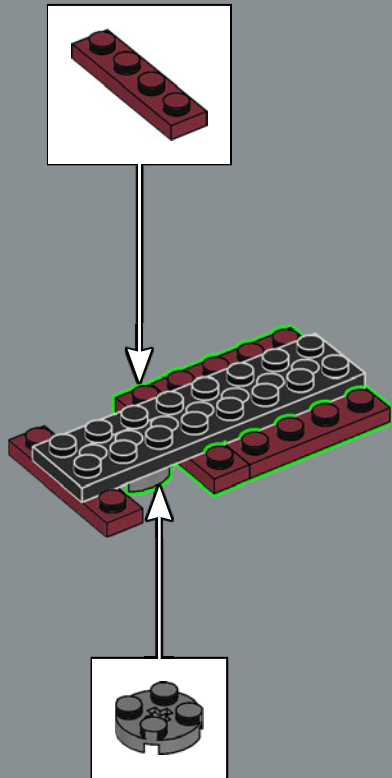
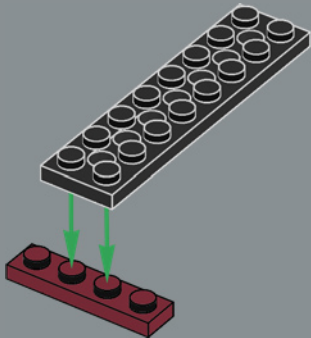

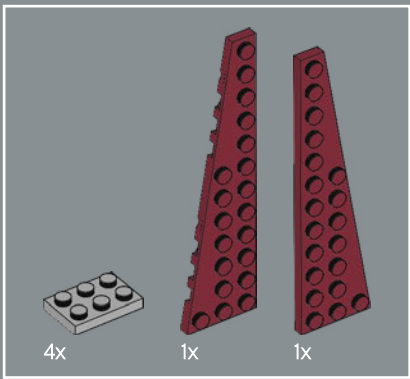

3

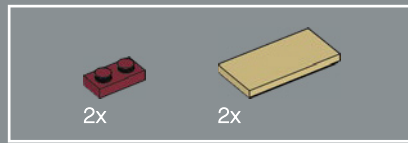
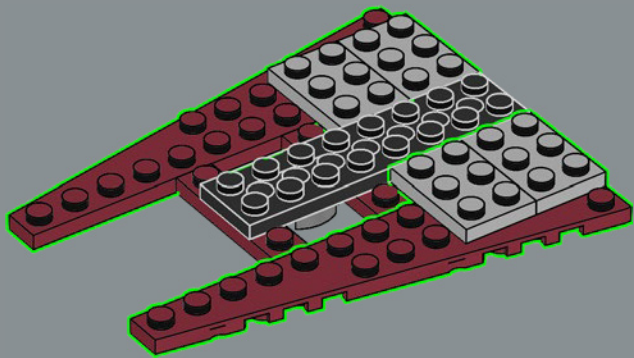

4

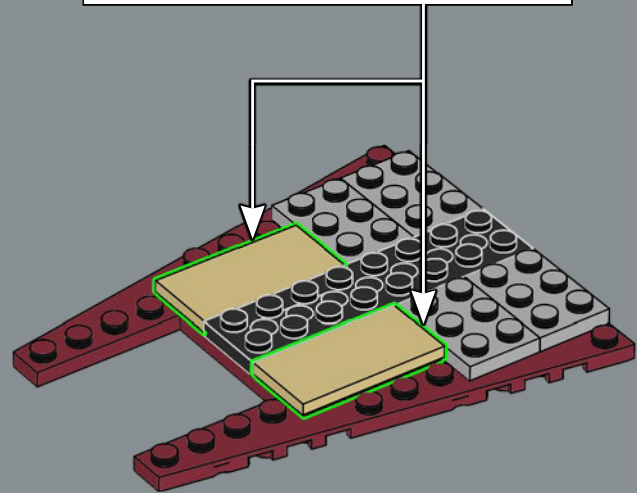
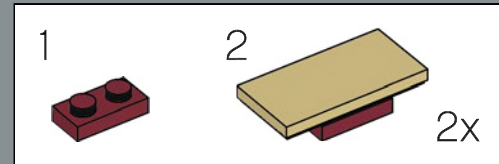

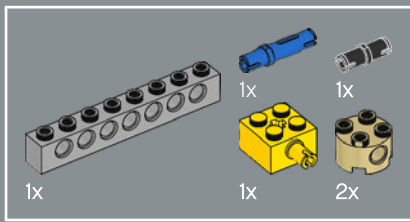

5

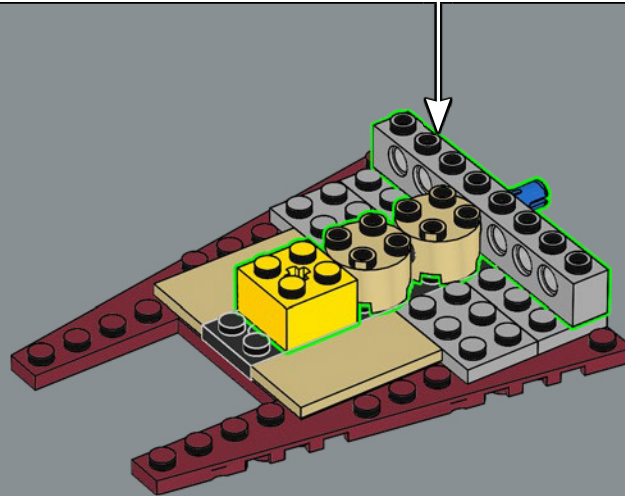
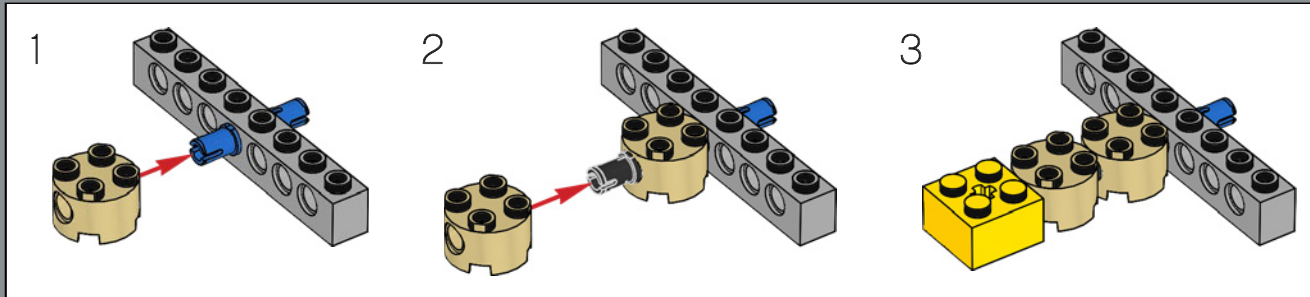

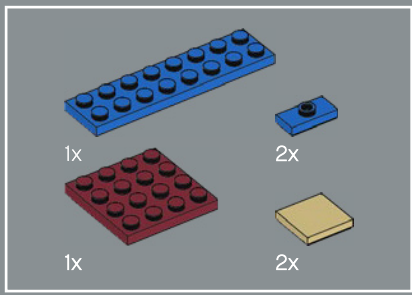

6

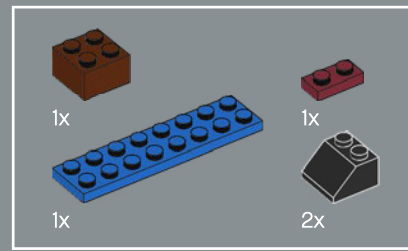
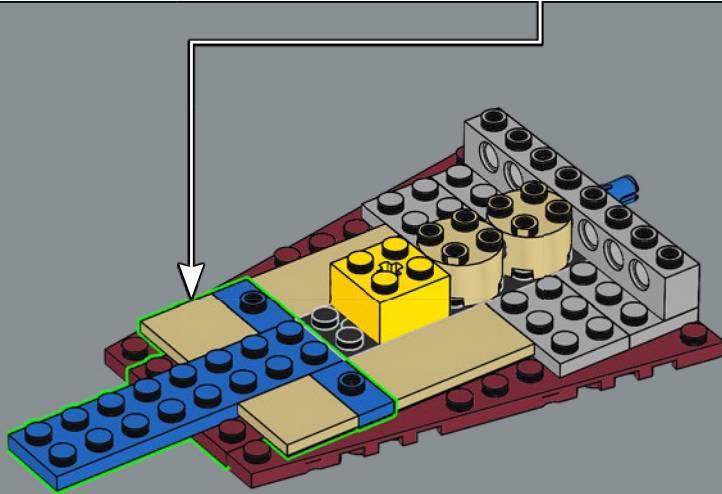
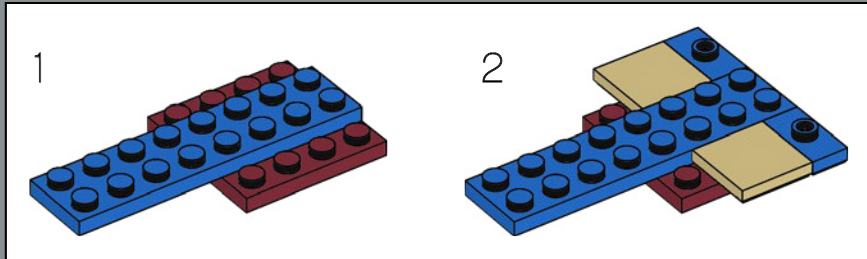

7

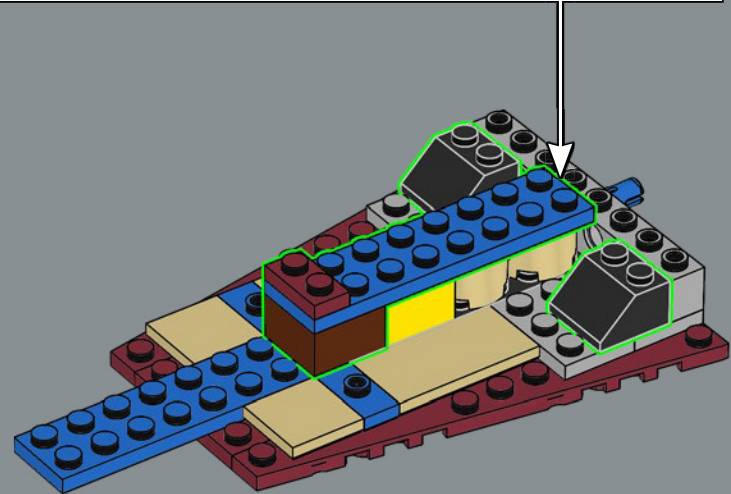
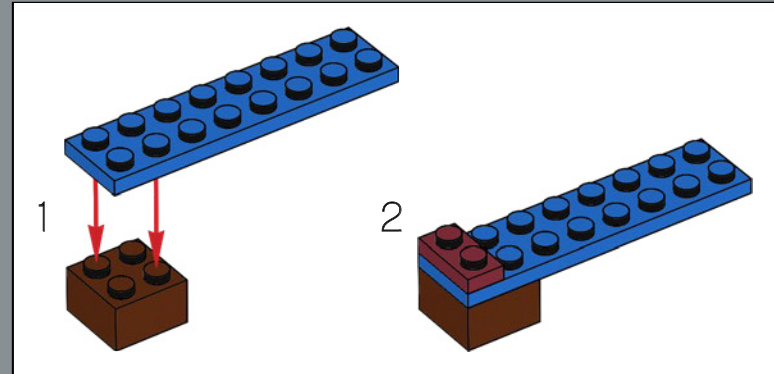

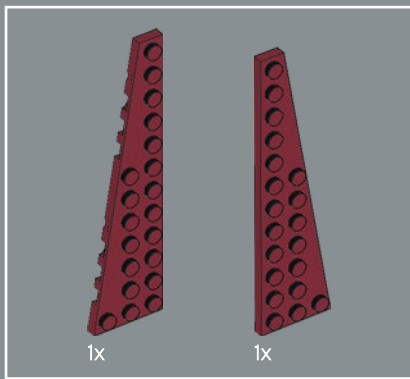

8

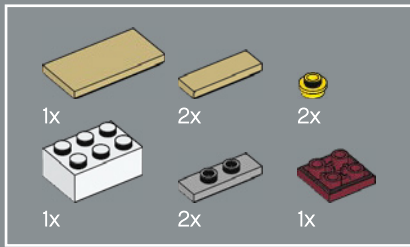
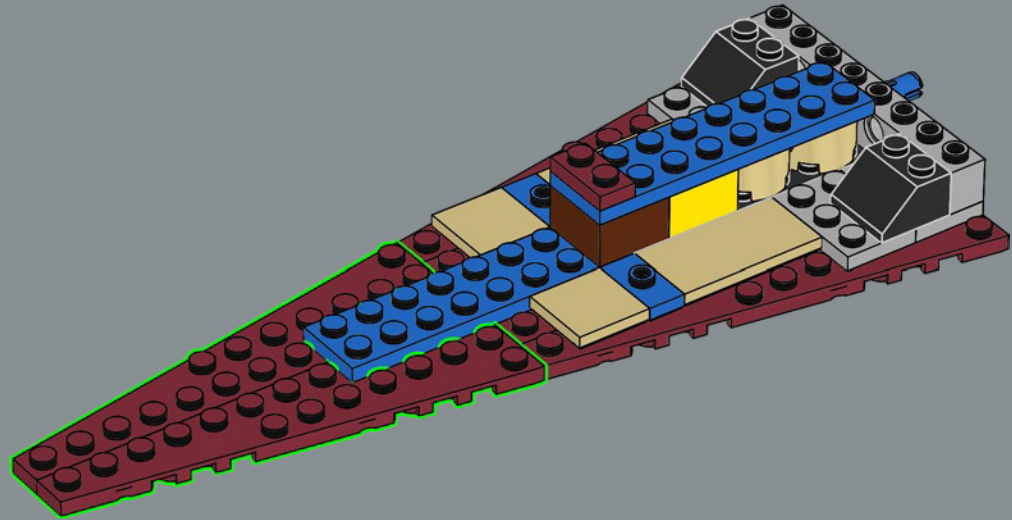

9

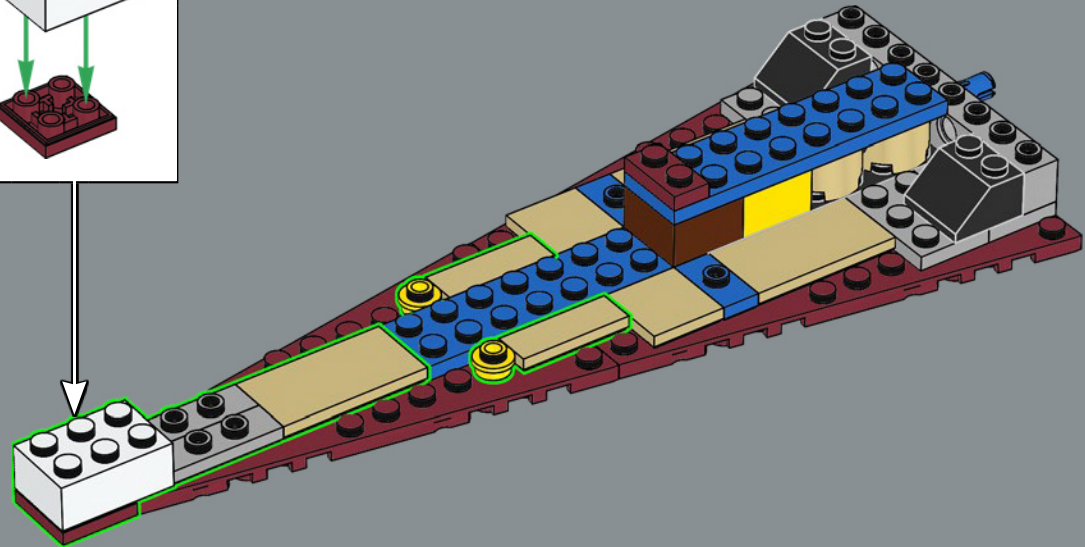
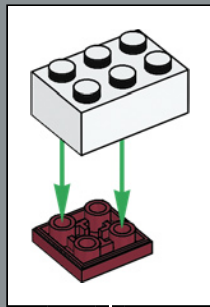

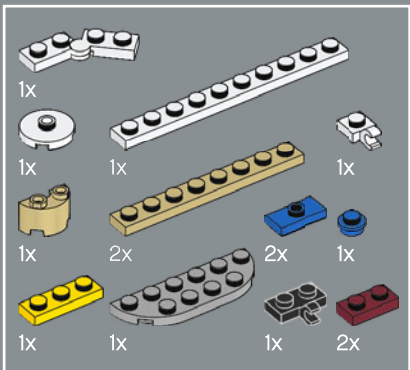

10

1

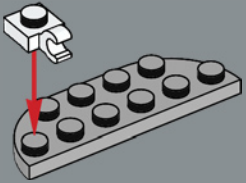

2

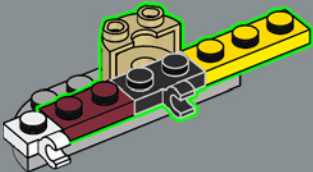

3

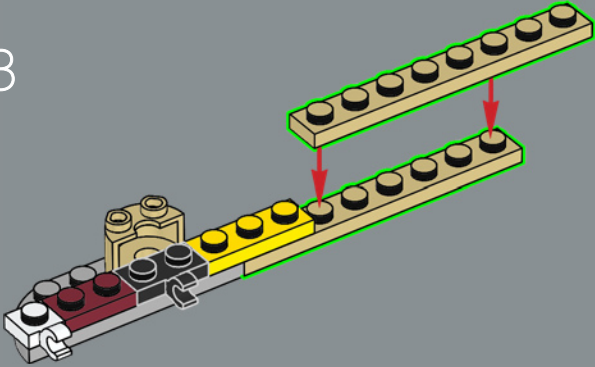

4

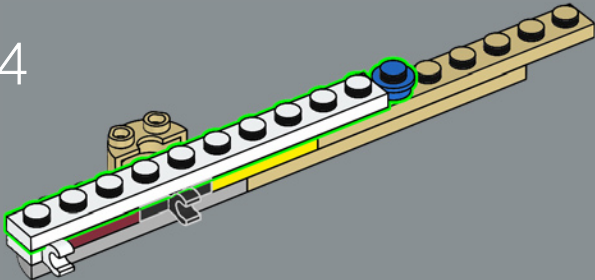

5

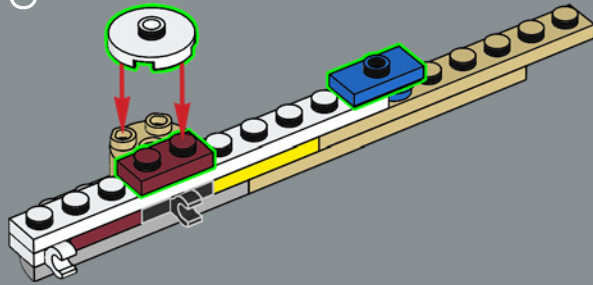

6

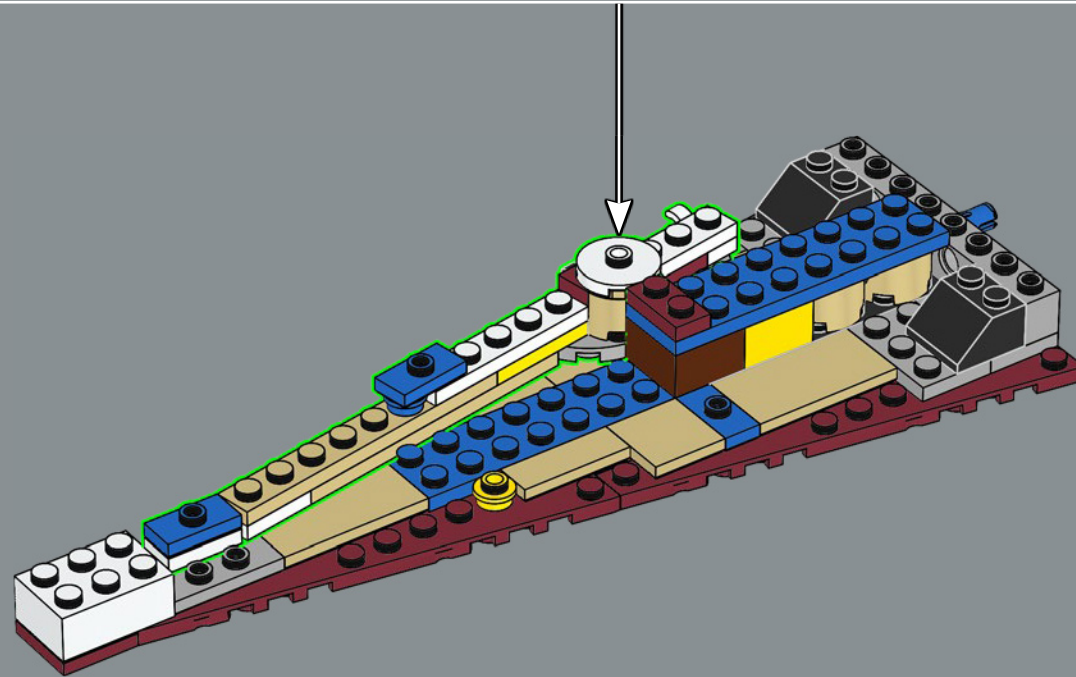
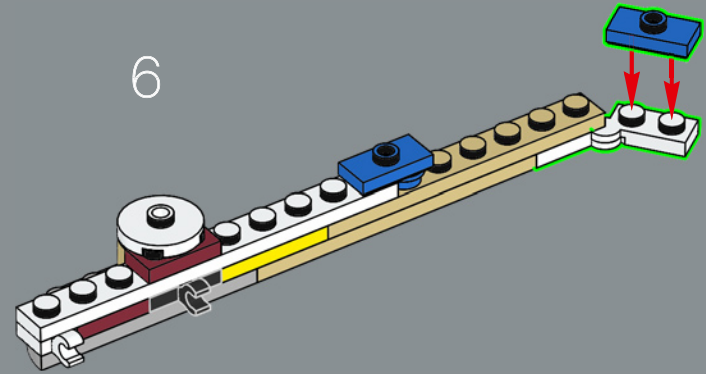





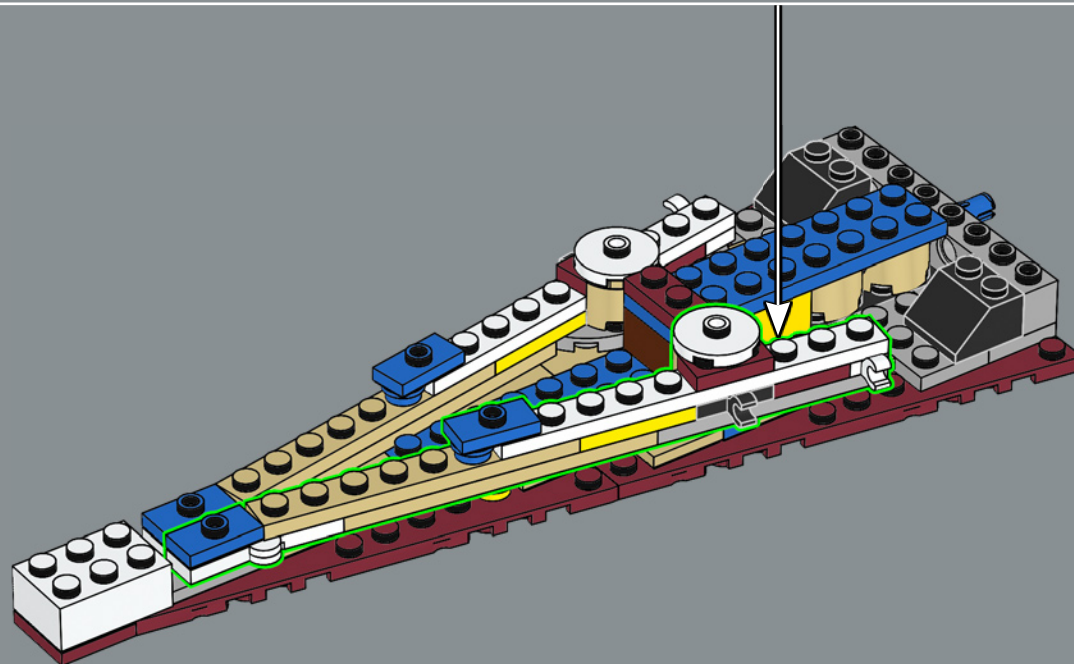
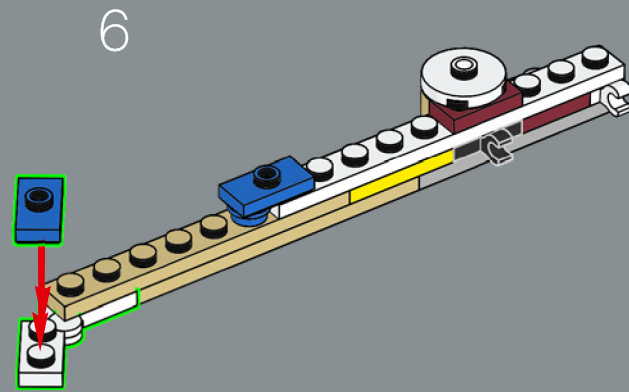
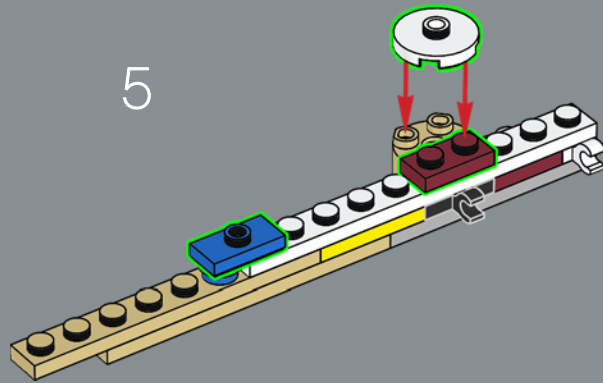

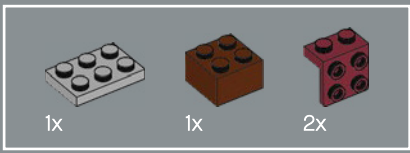

12

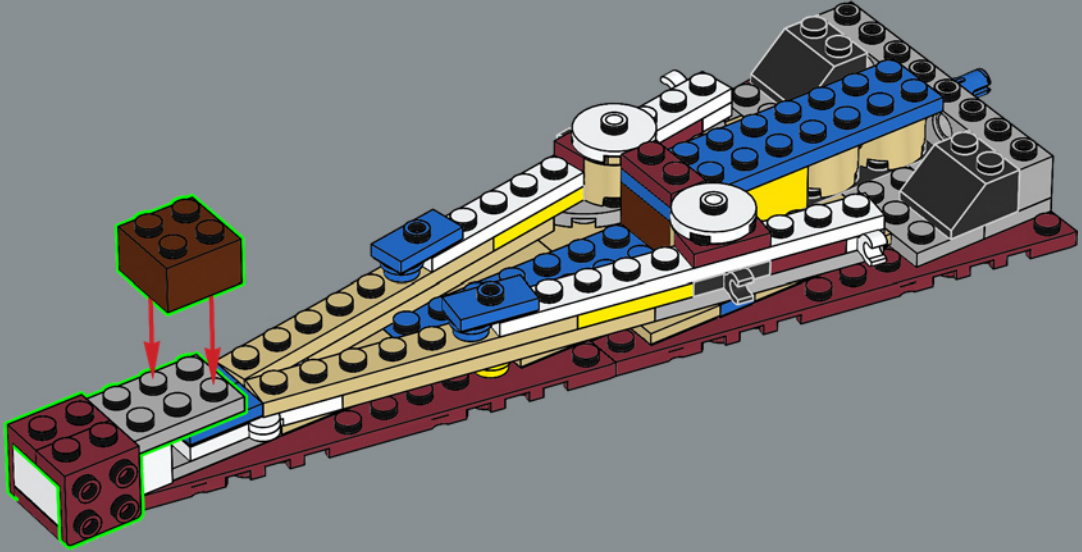

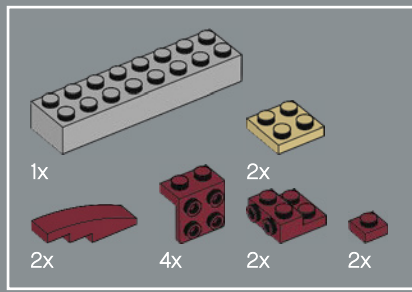

13

1

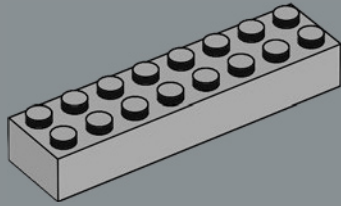

2

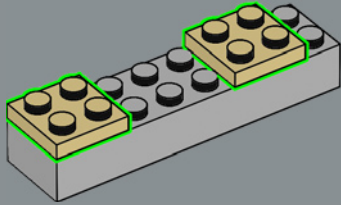

3

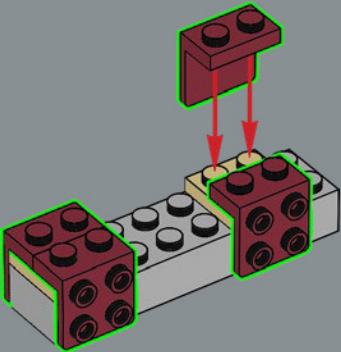

4

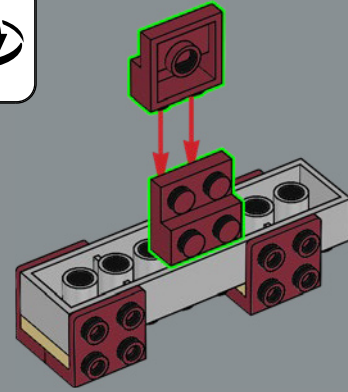

5

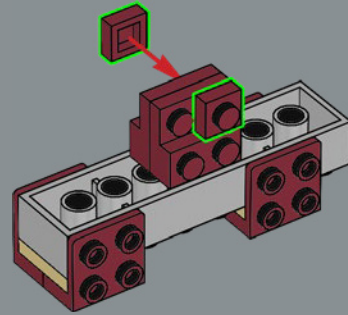

6

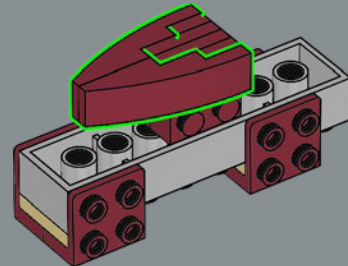

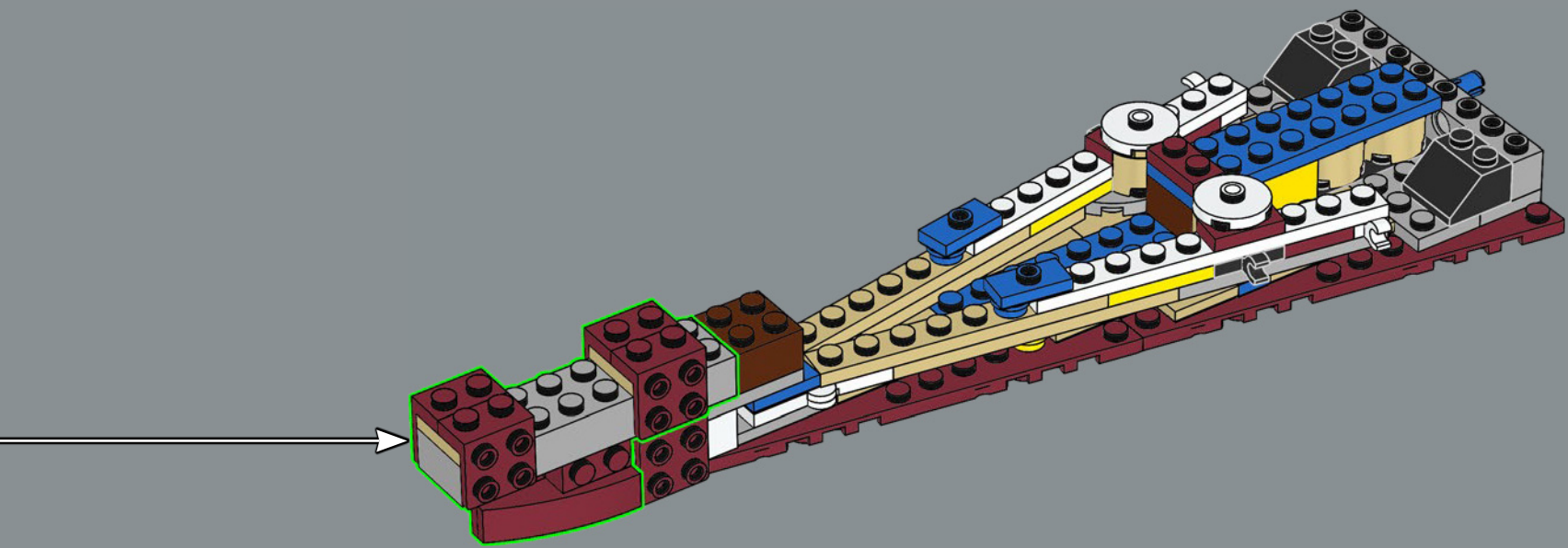

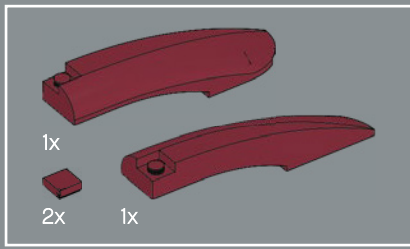

14

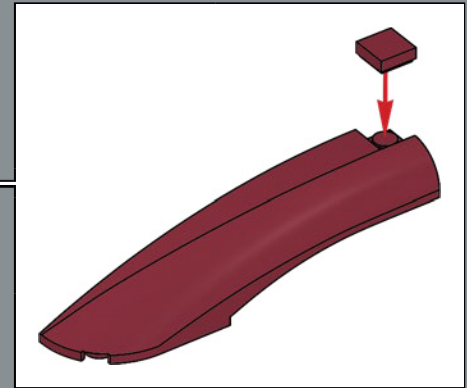
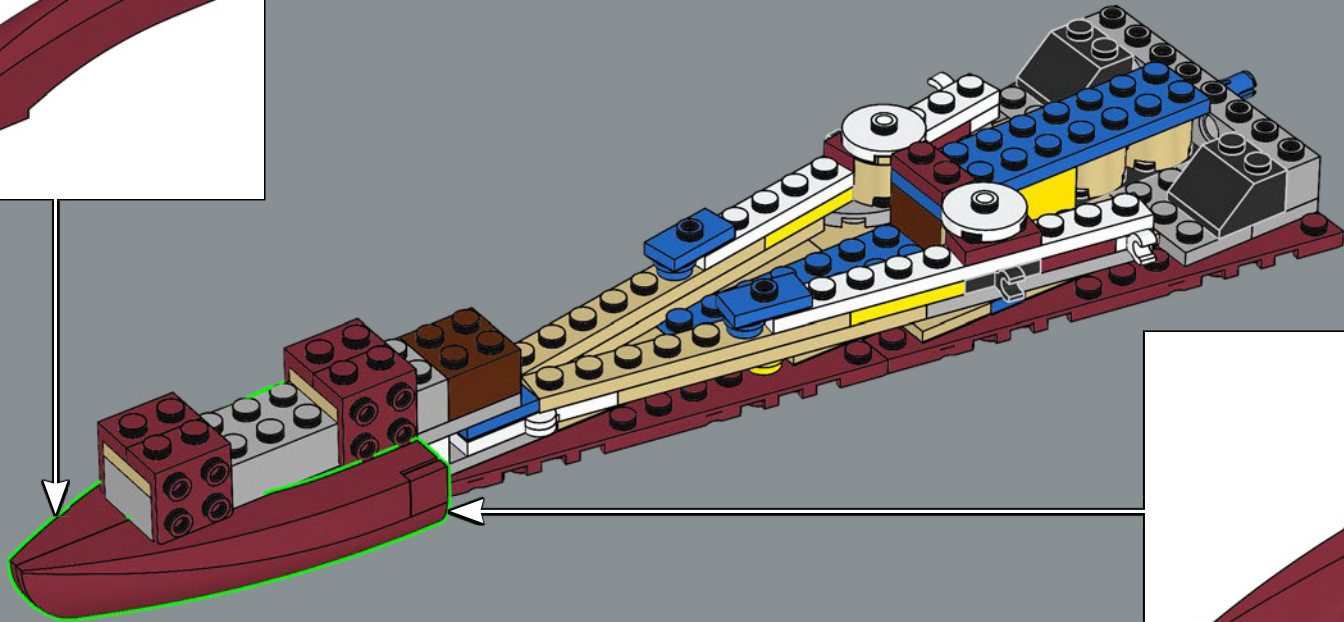
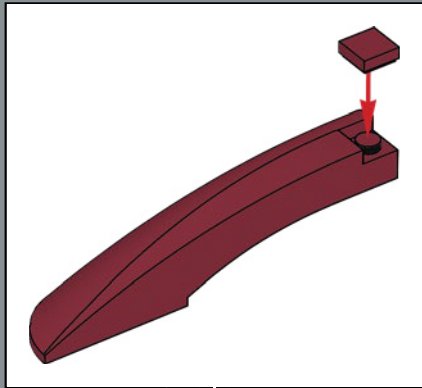

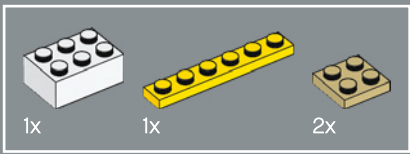

15

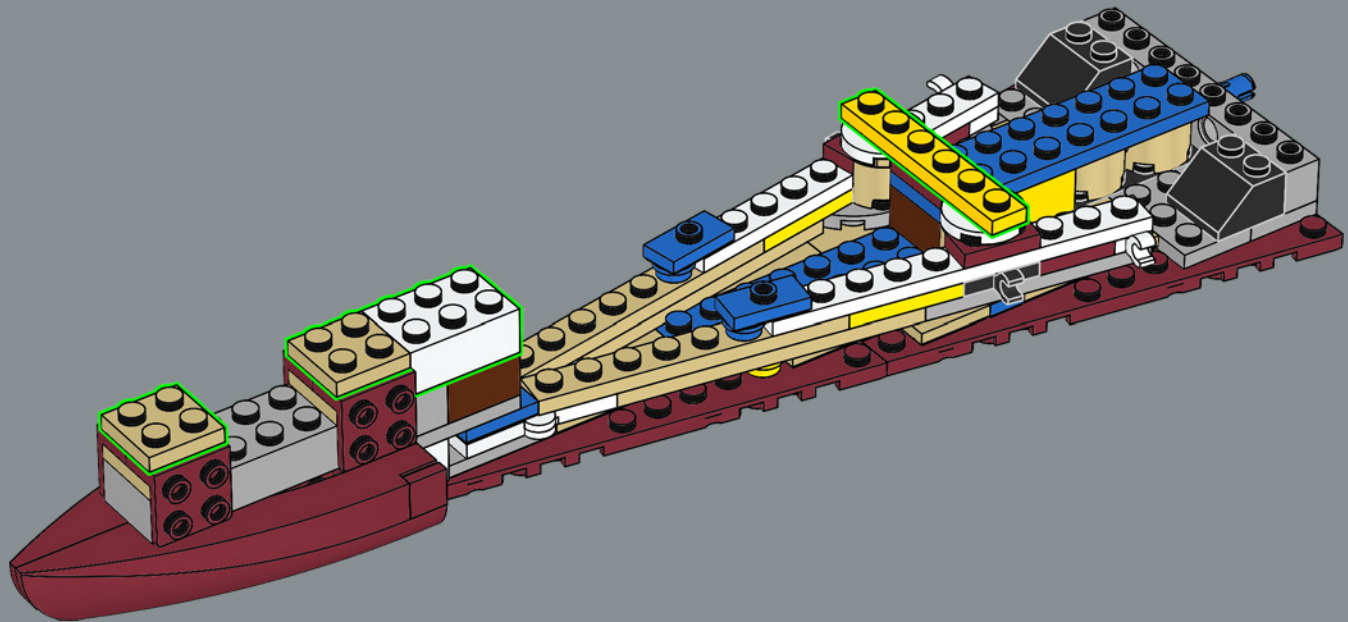

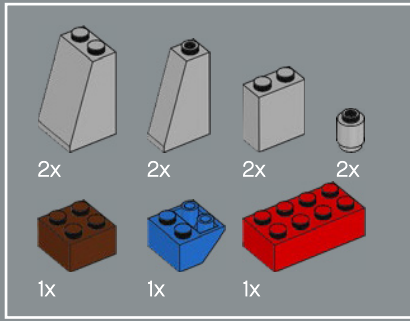

16

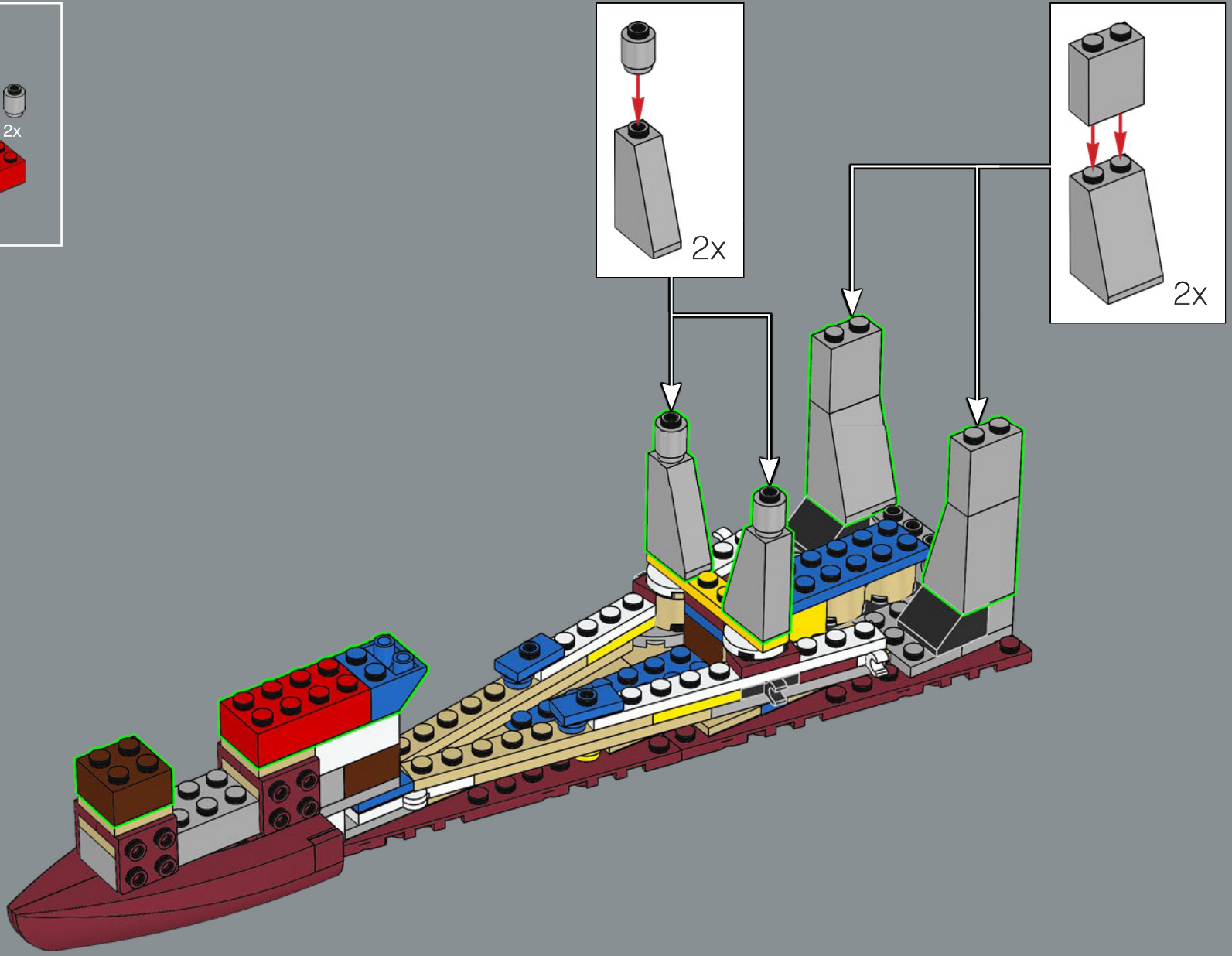

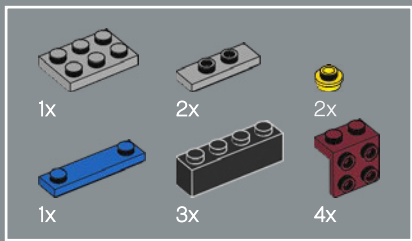

17

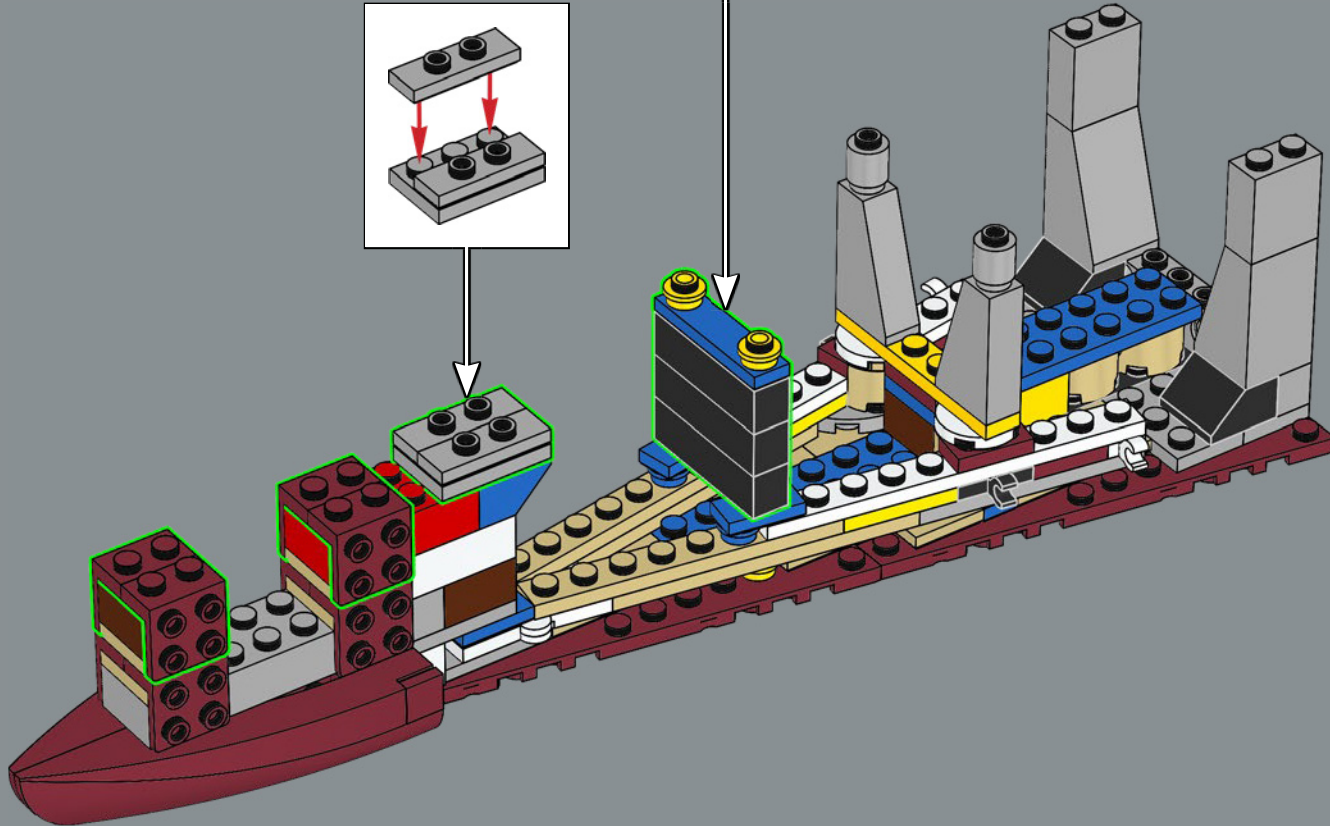
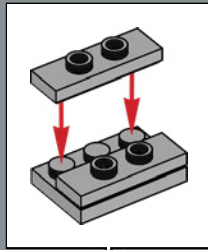
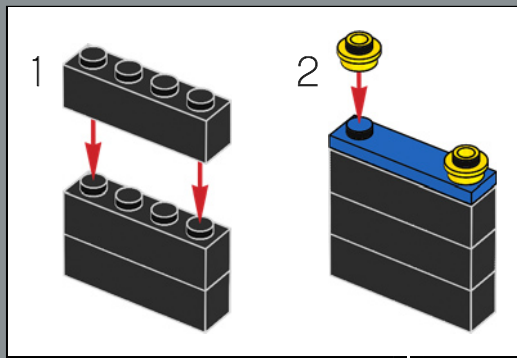



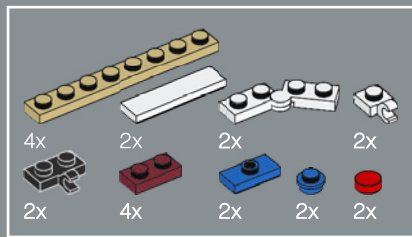

18

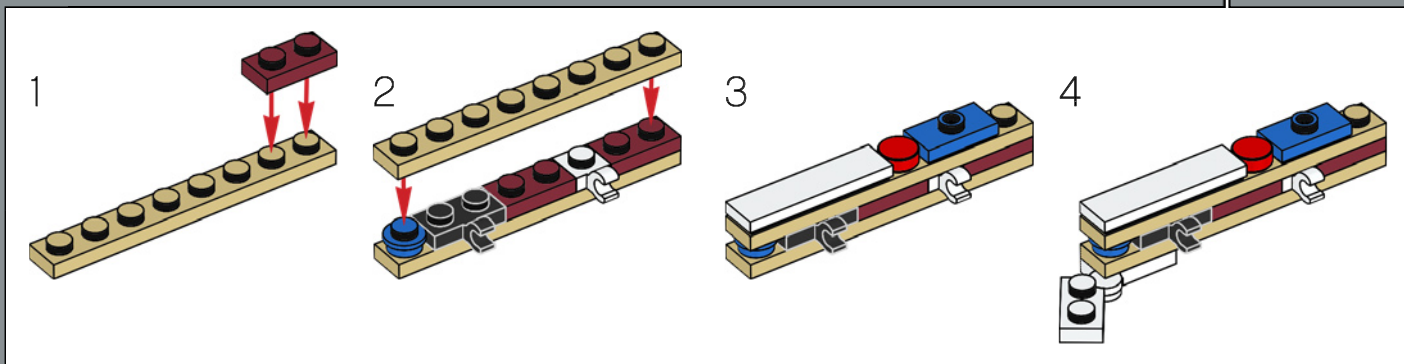
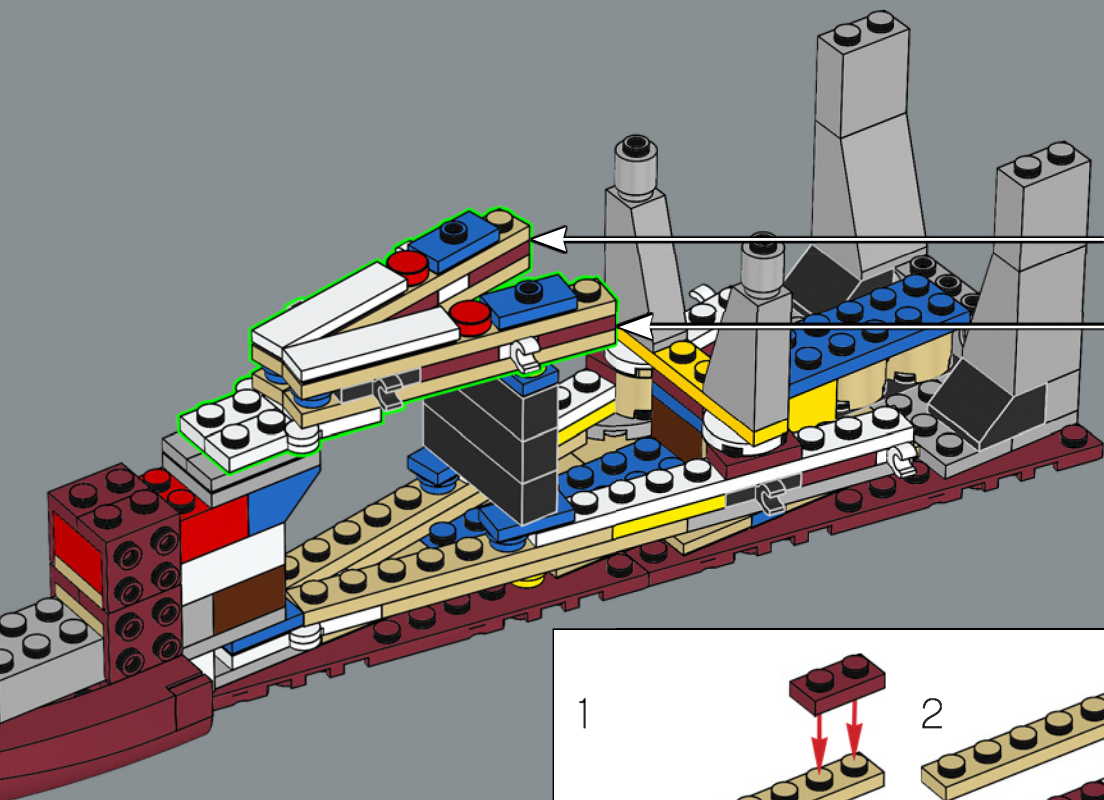
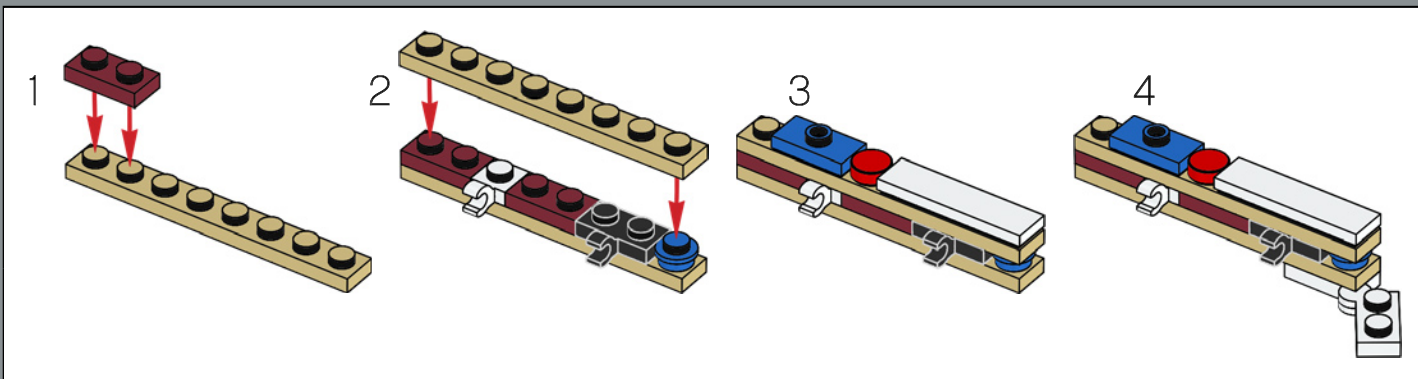

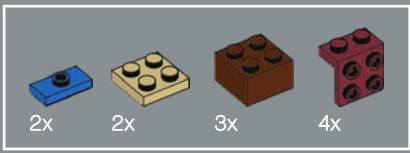

19

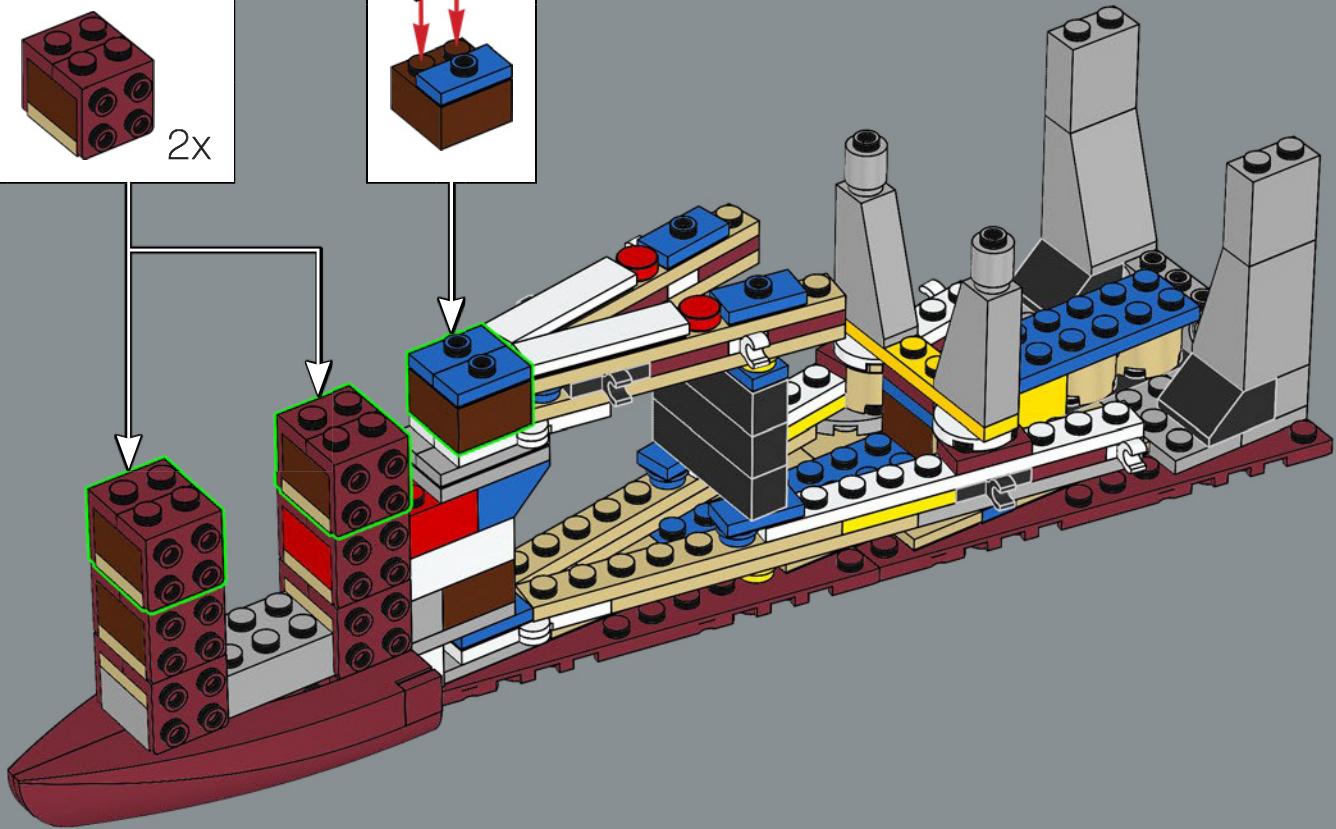
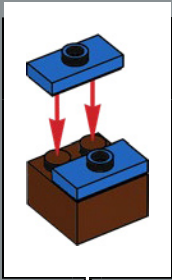
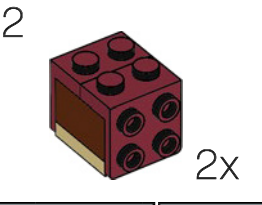
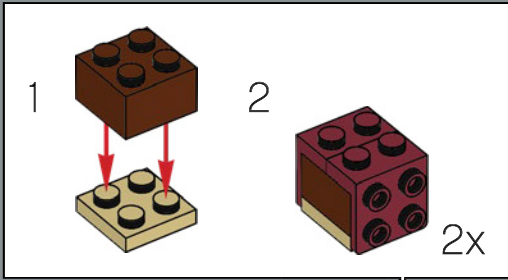

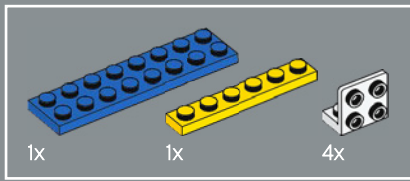

20

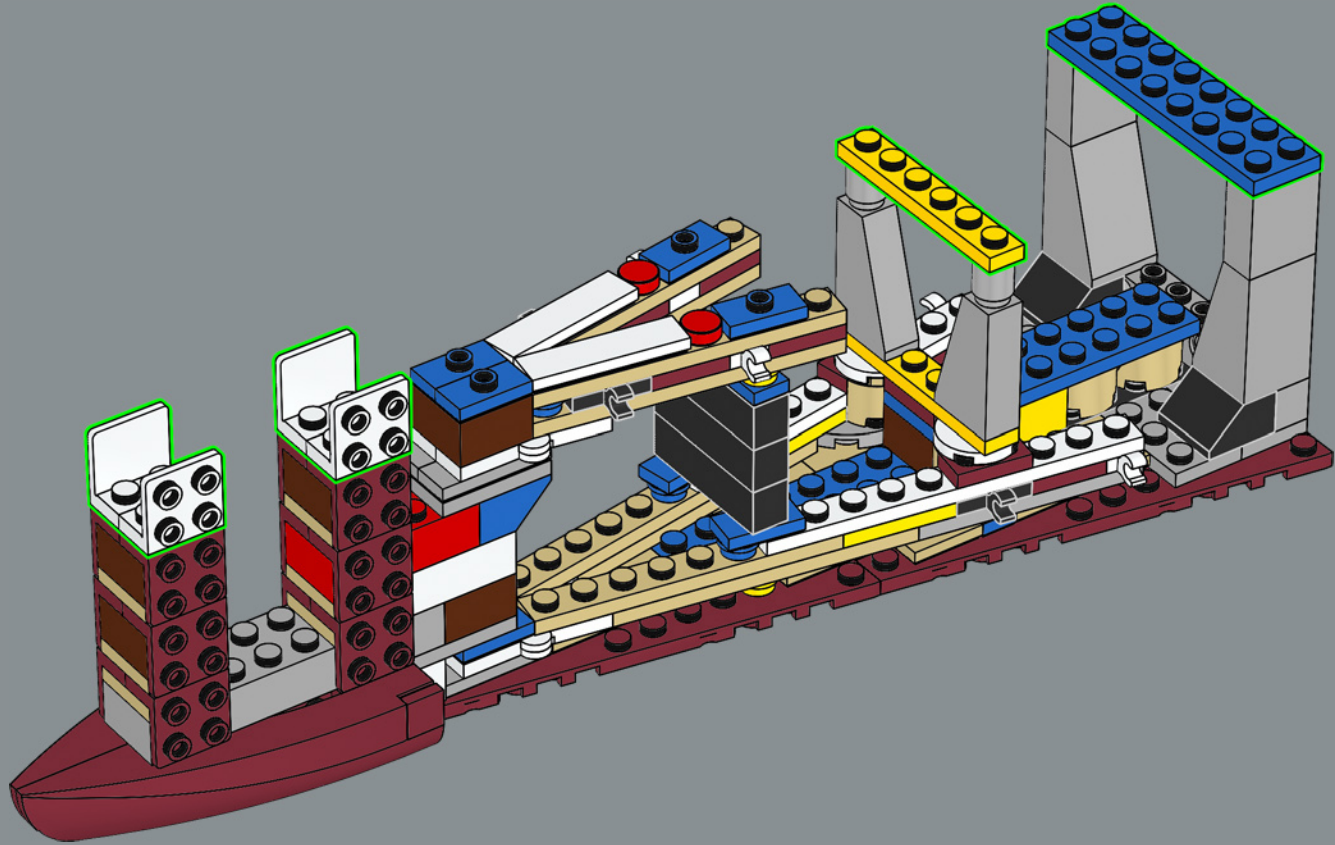

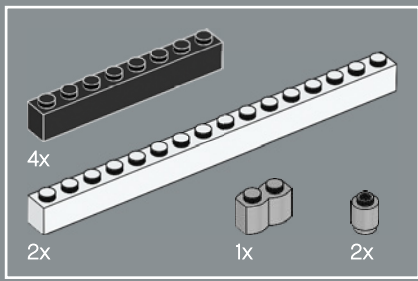

21

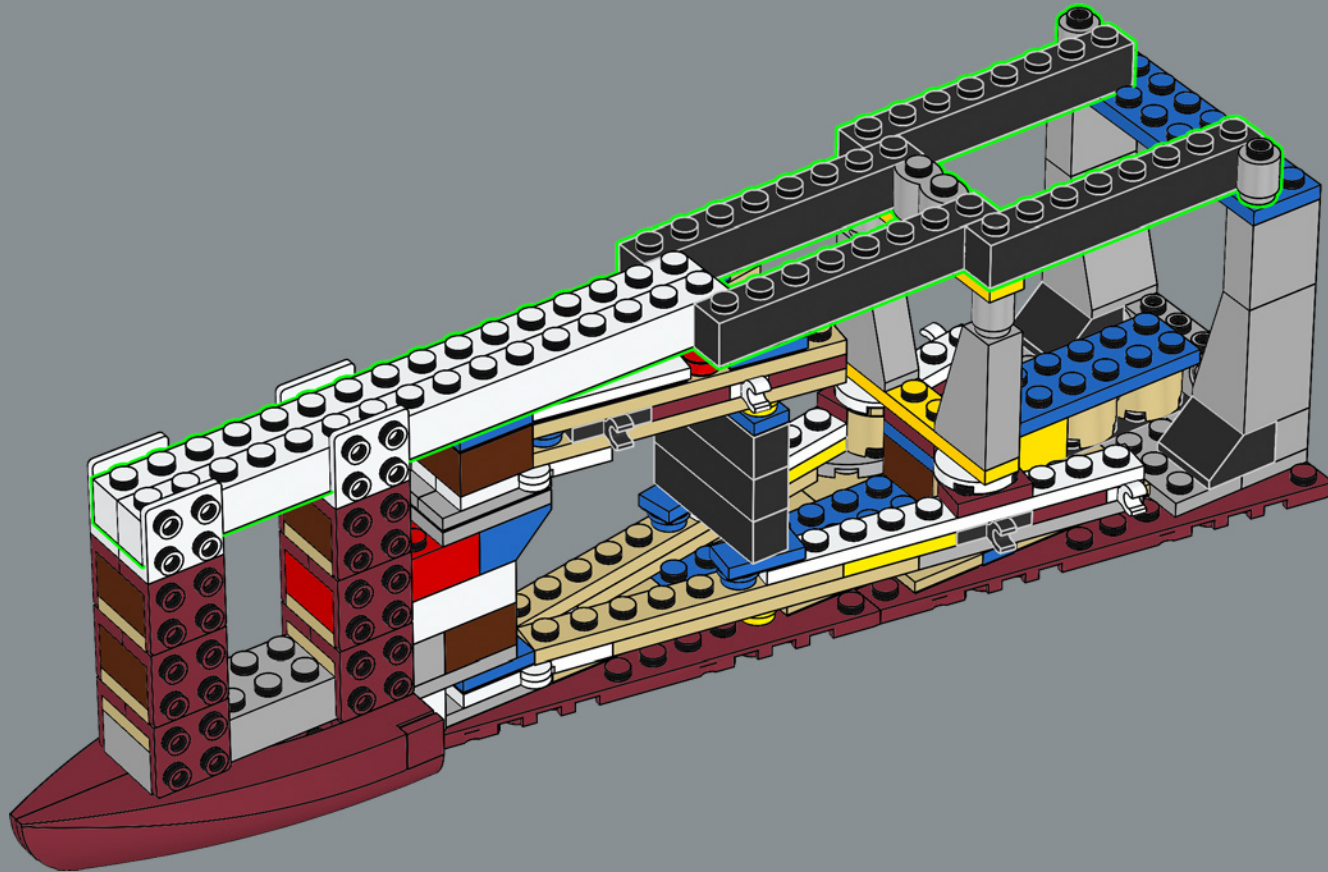

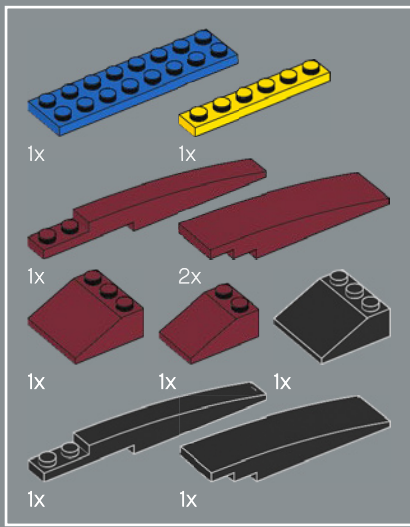

22

1

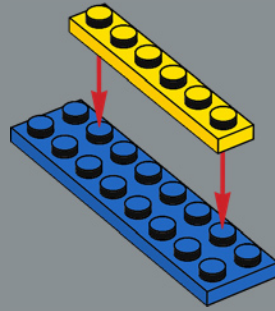

2

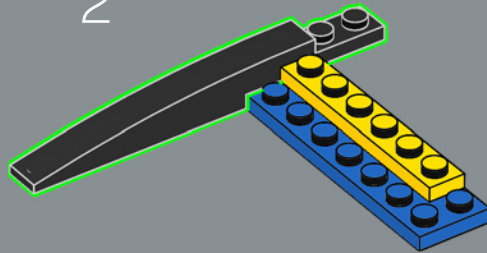

3

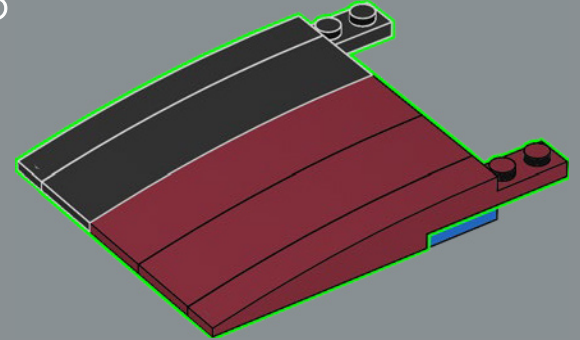

4

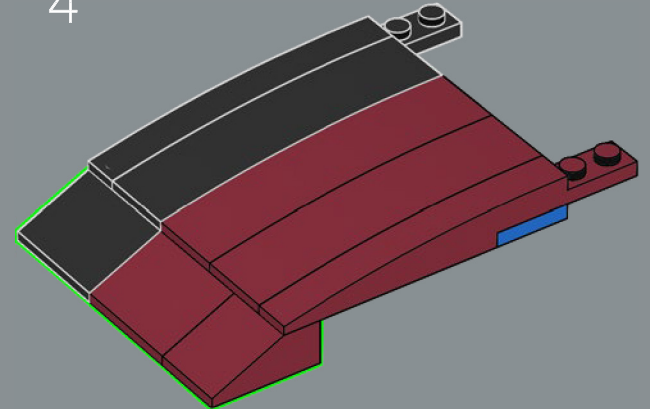

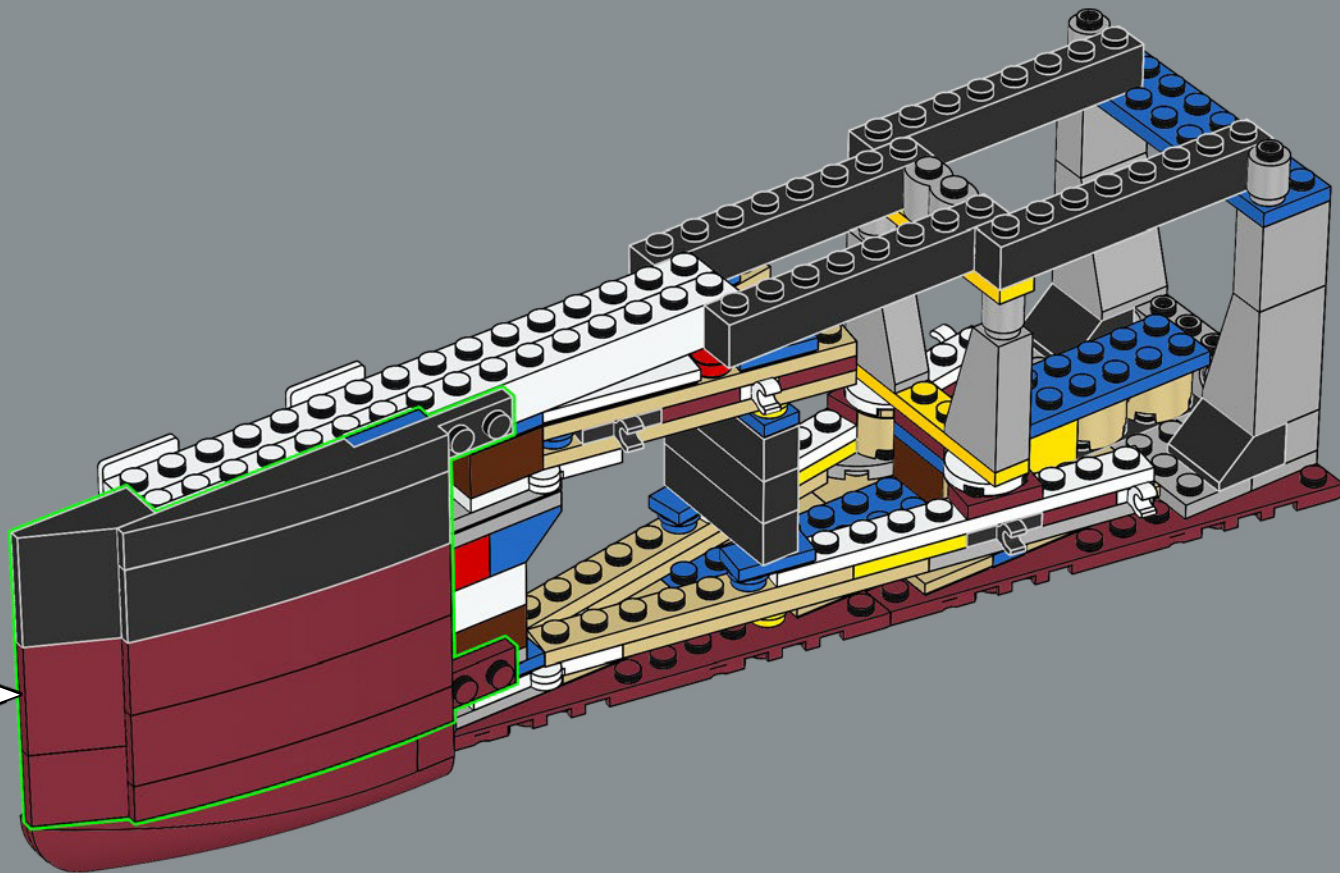

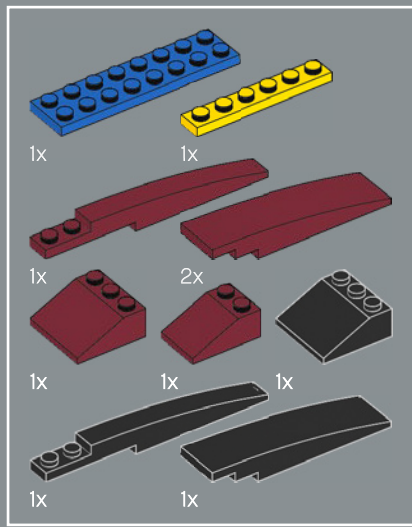

23

1

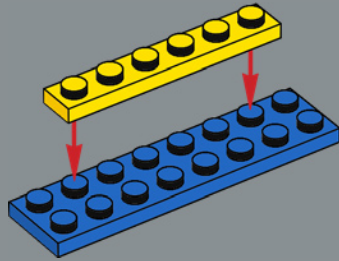

2

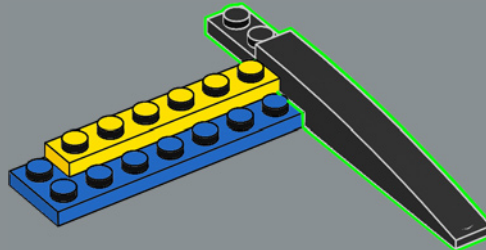

3

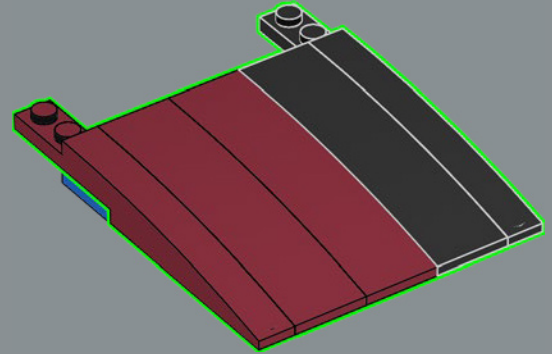

4

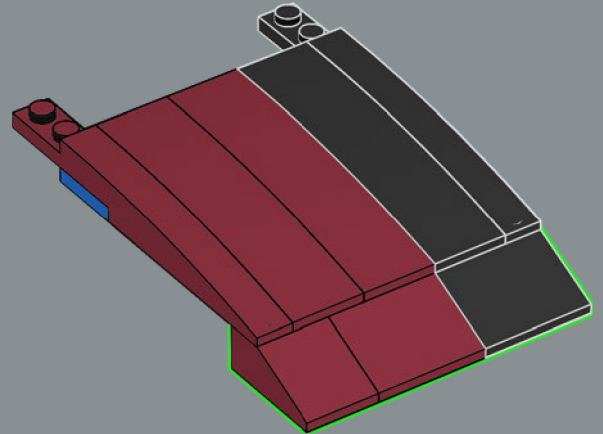

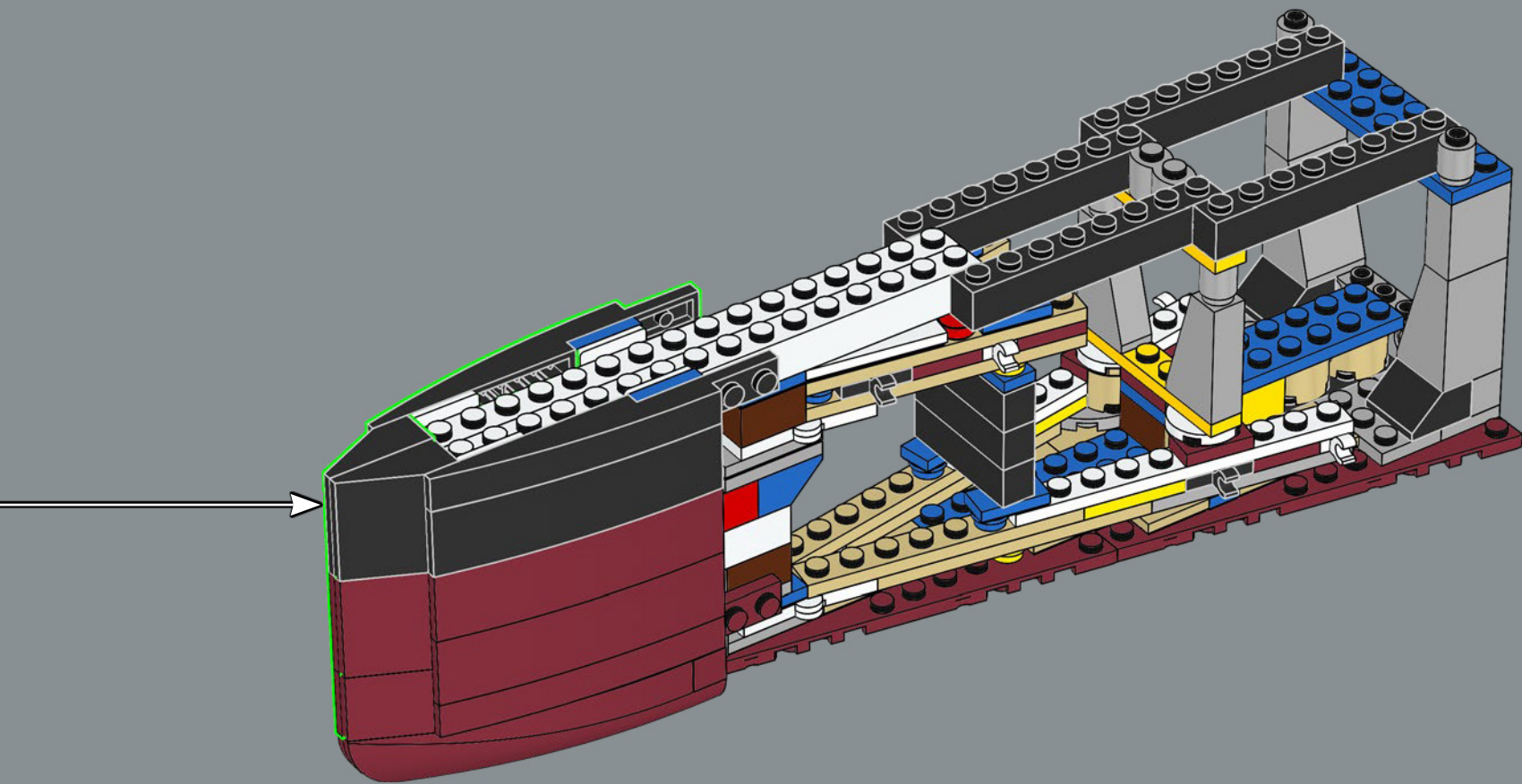



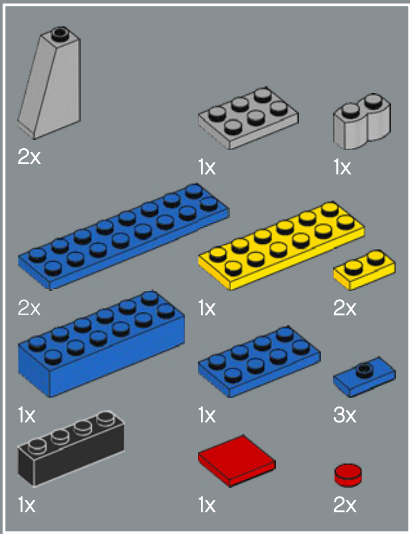
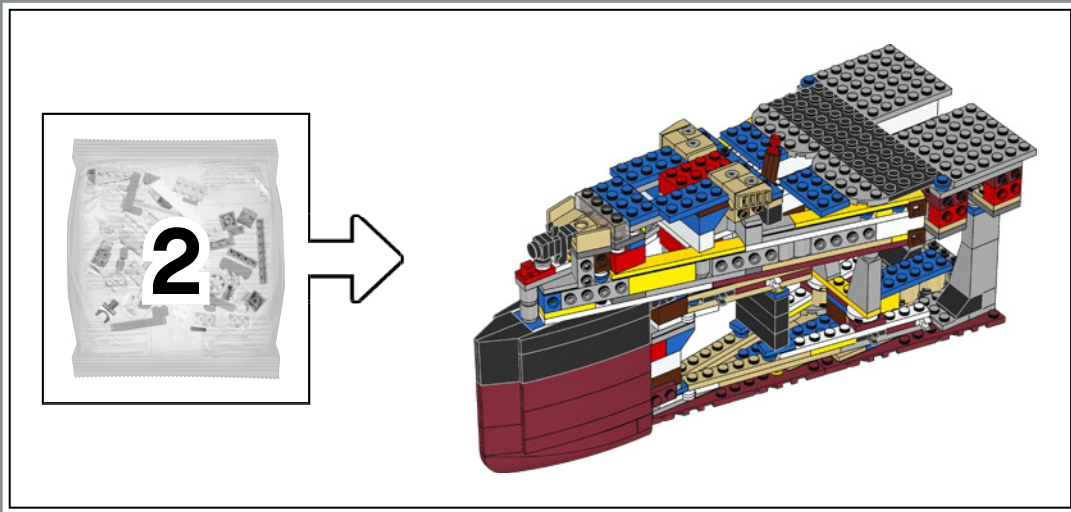

24

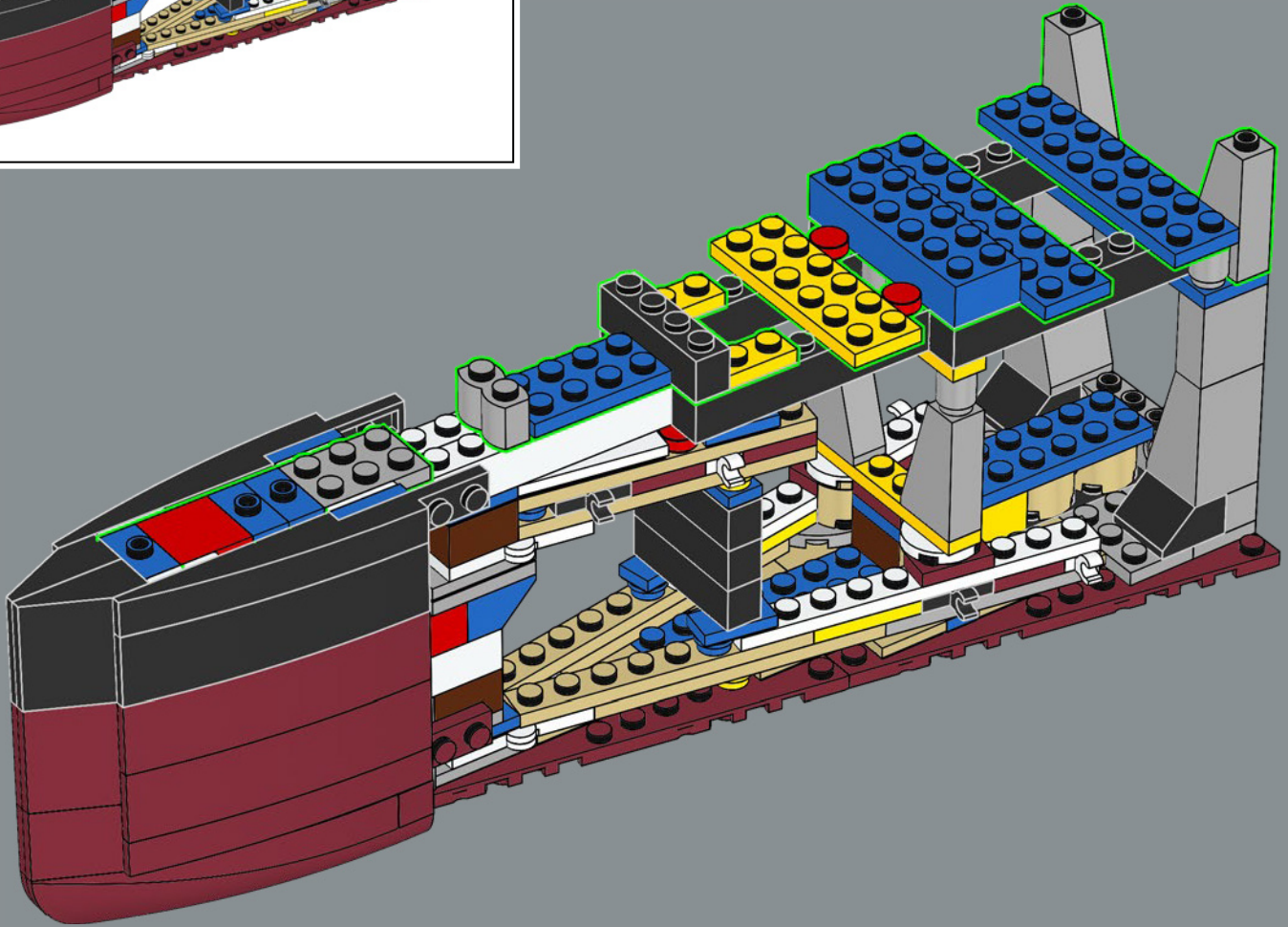

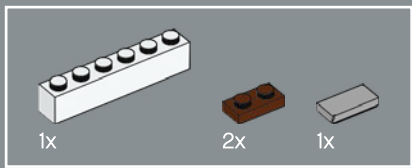

25

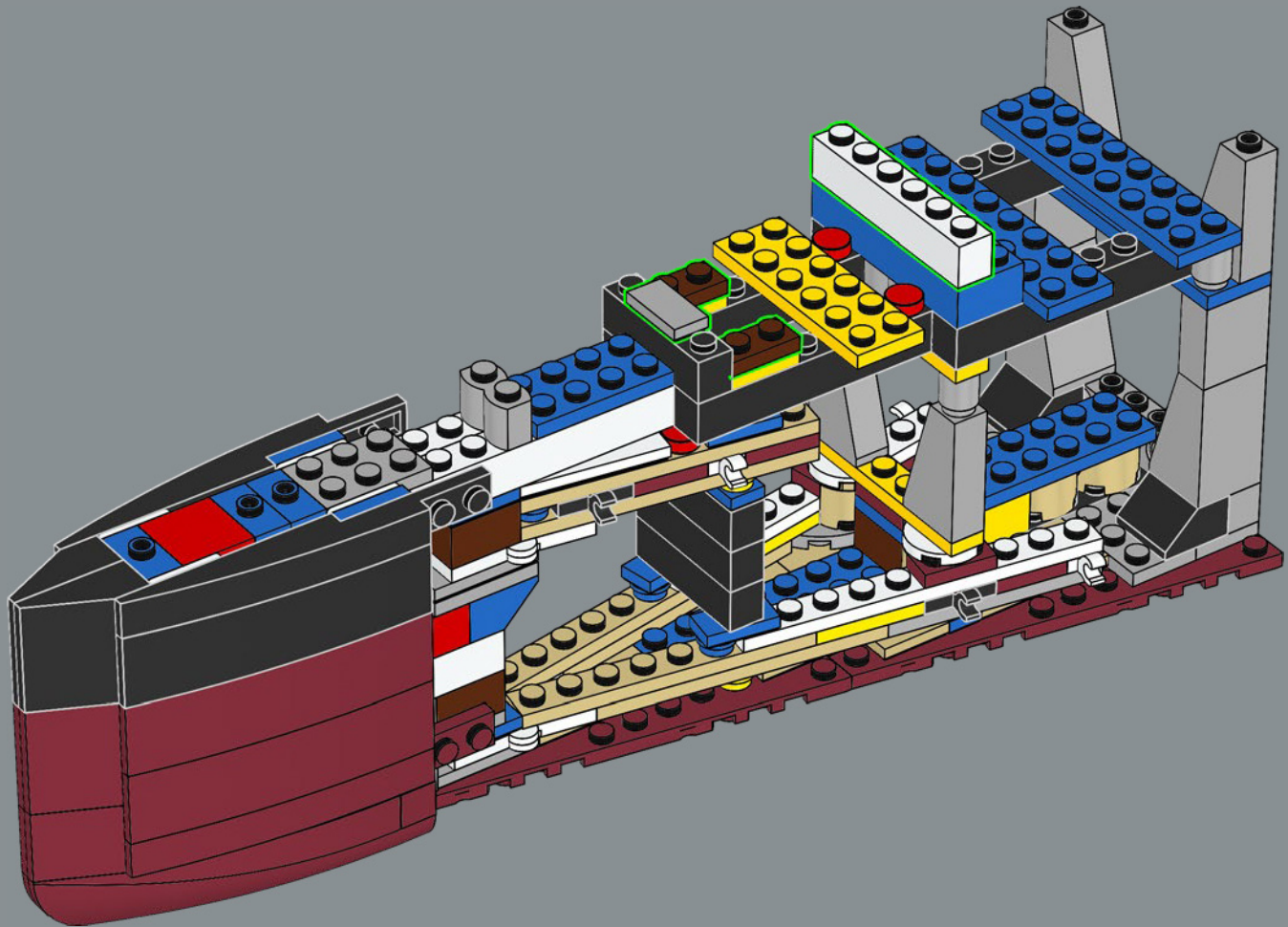

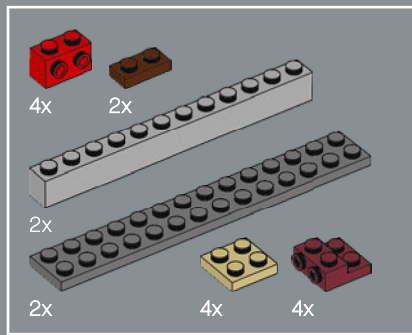

26

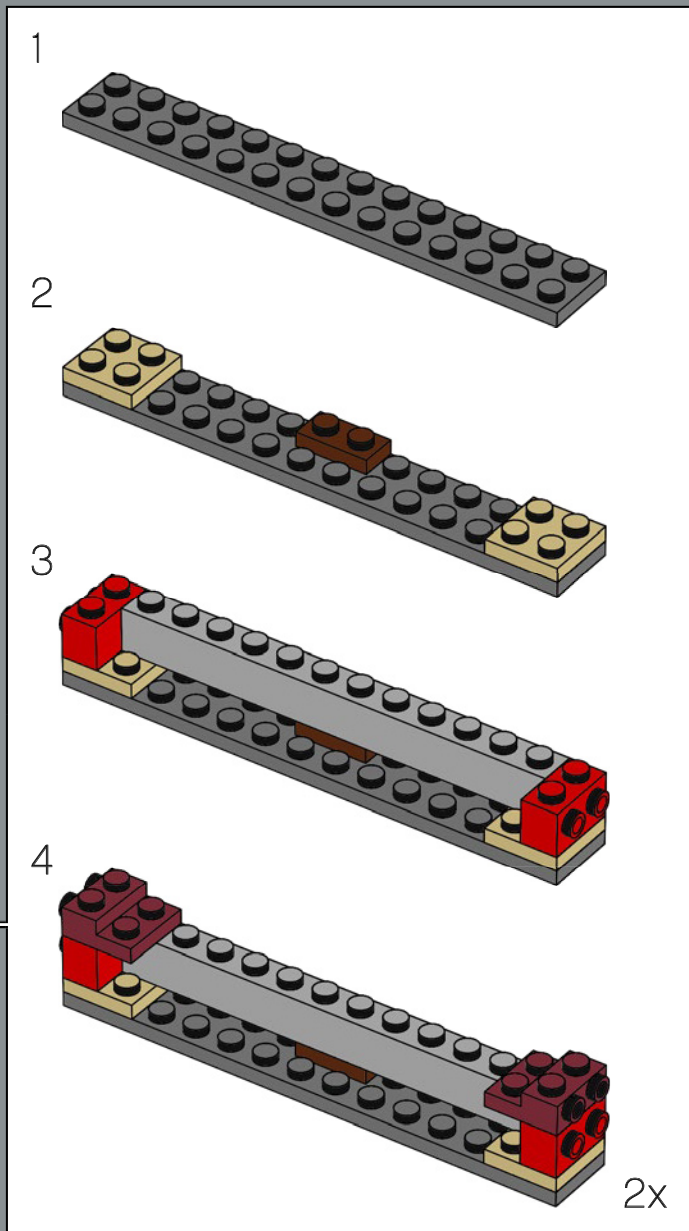
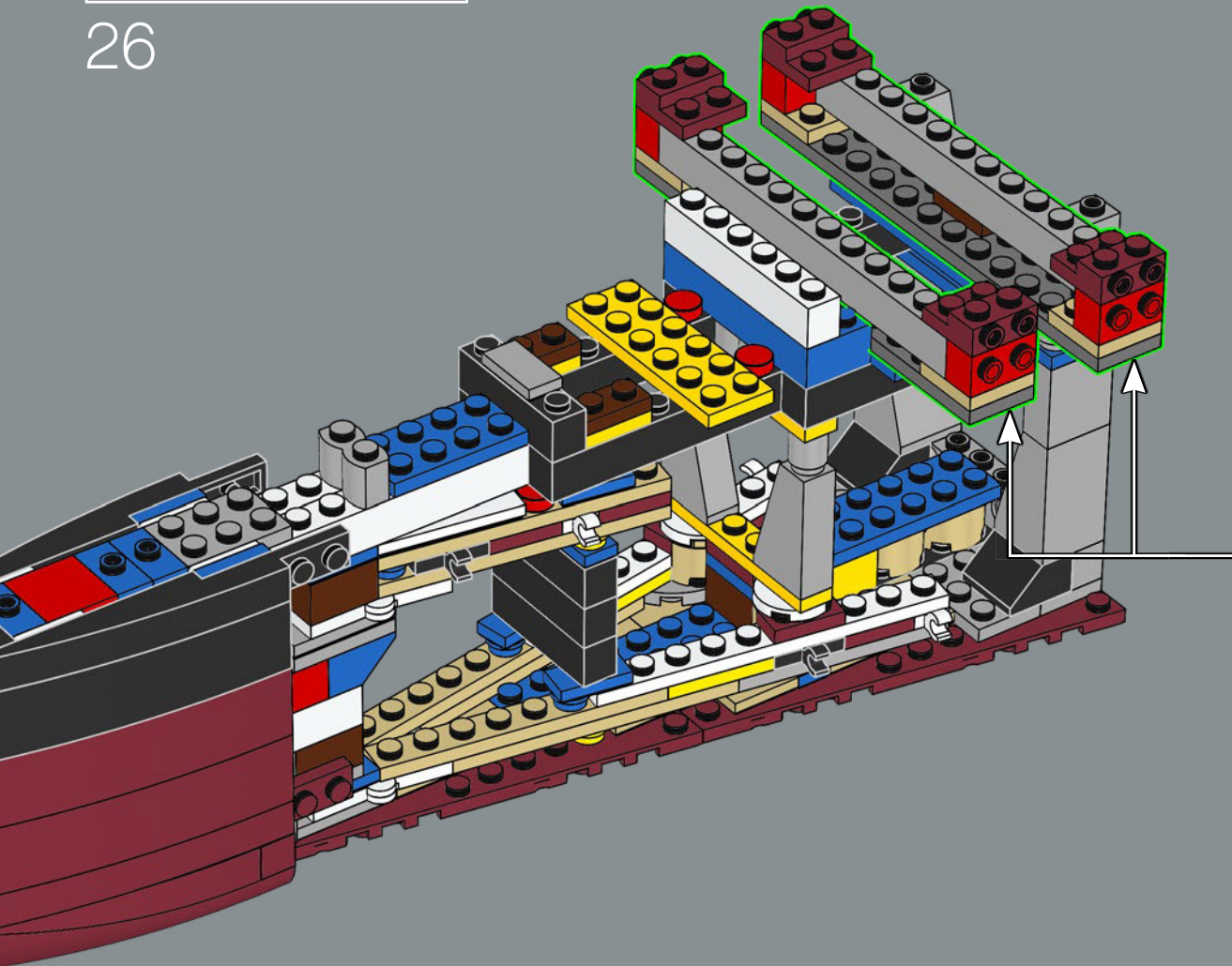

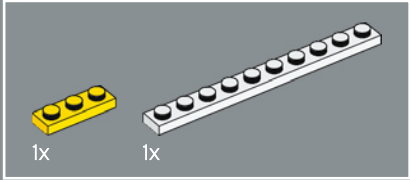
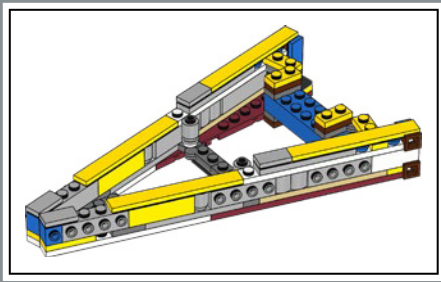

27

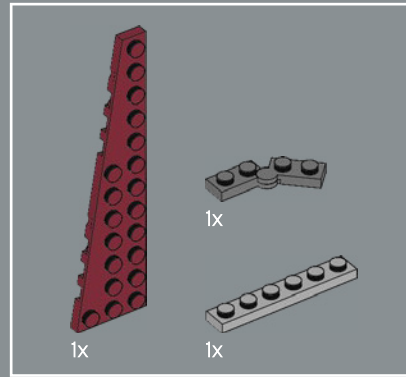
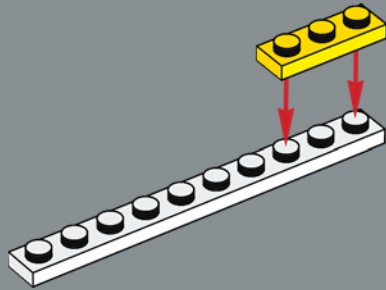

28

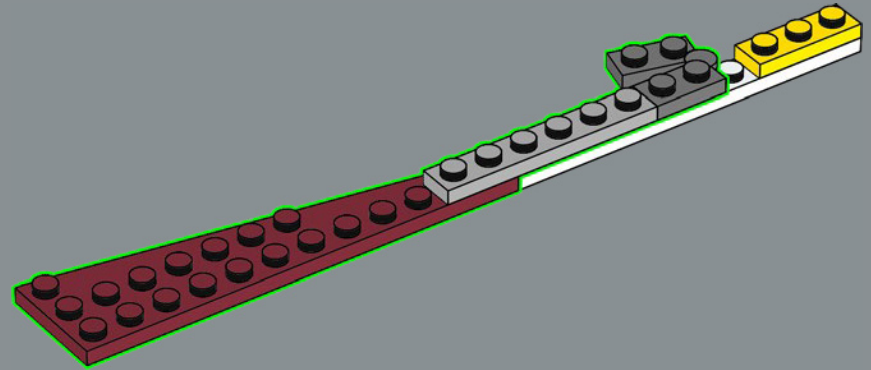

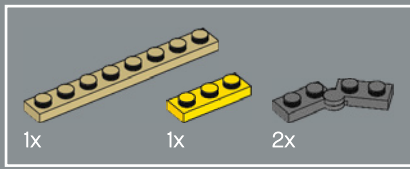

29

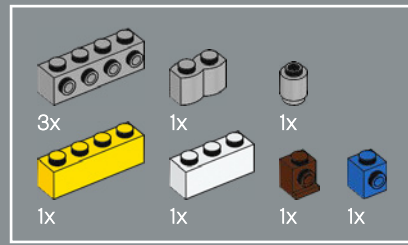
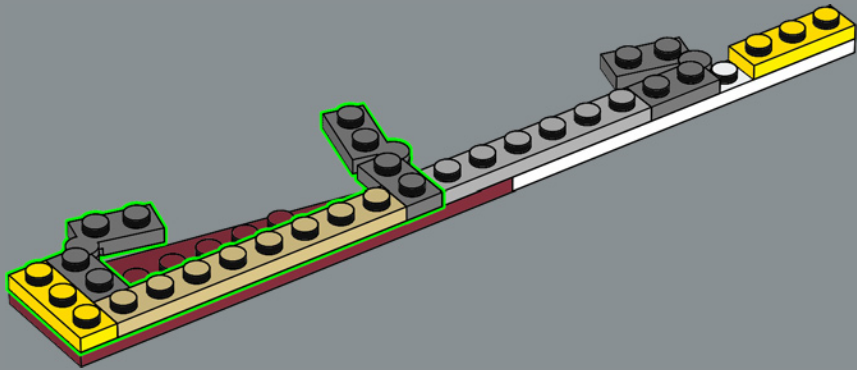

30

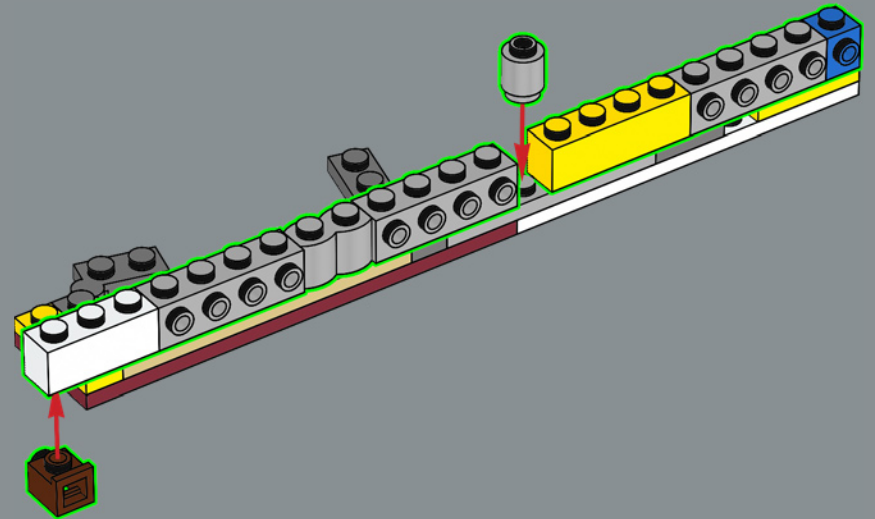

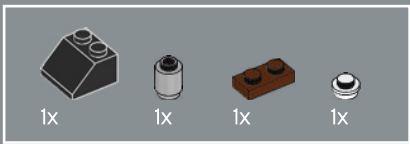

31

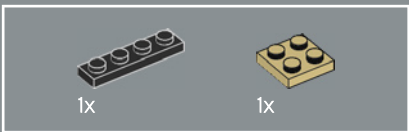
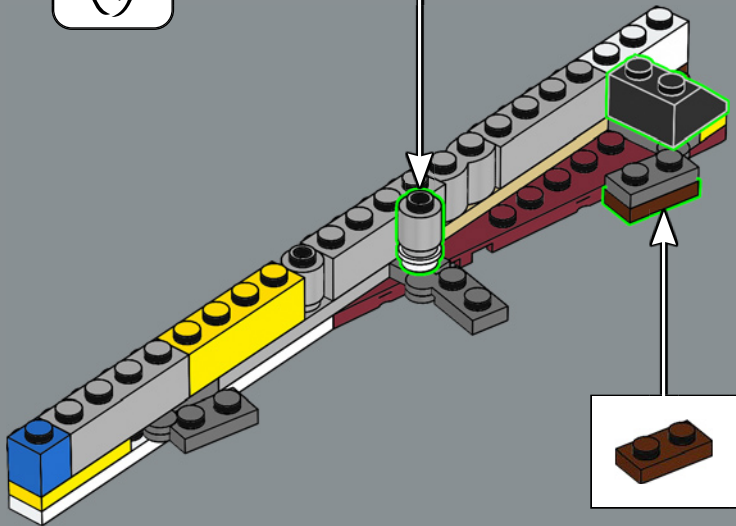
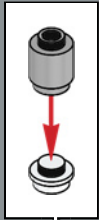

32

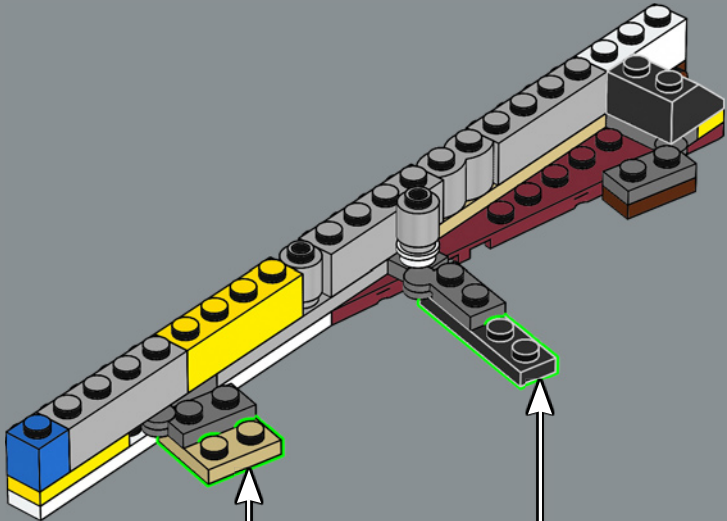

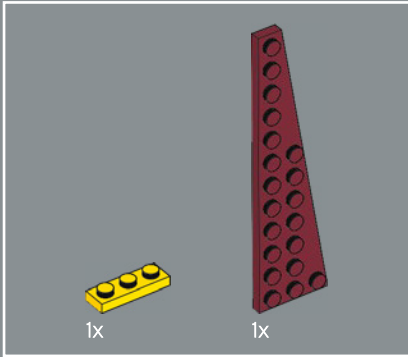
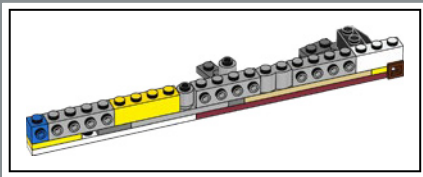

33

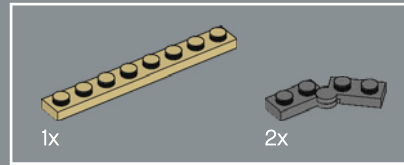
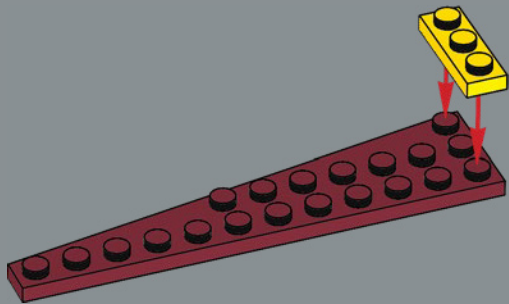

34

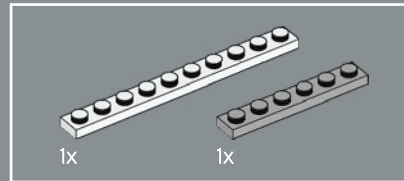
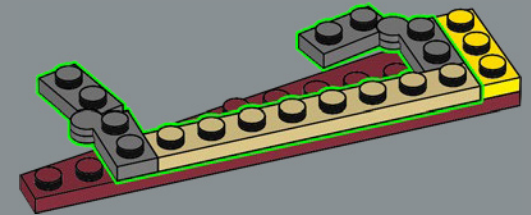

35

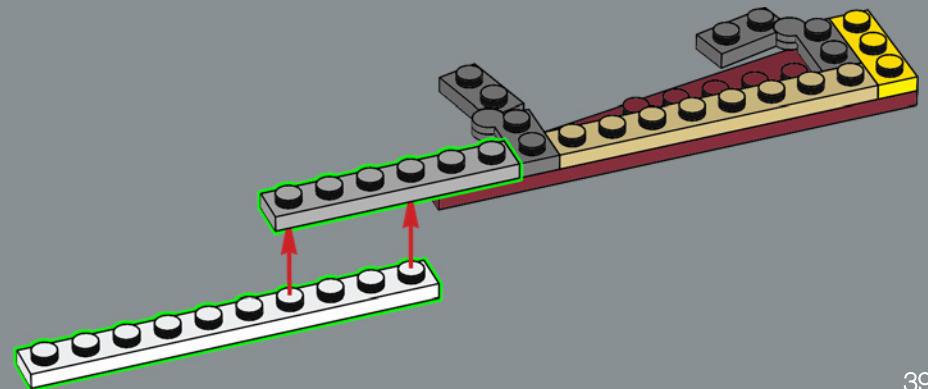

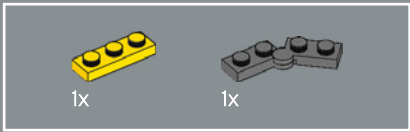

36

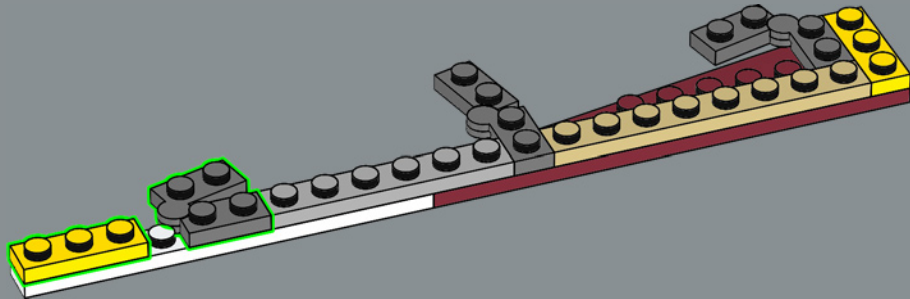

37

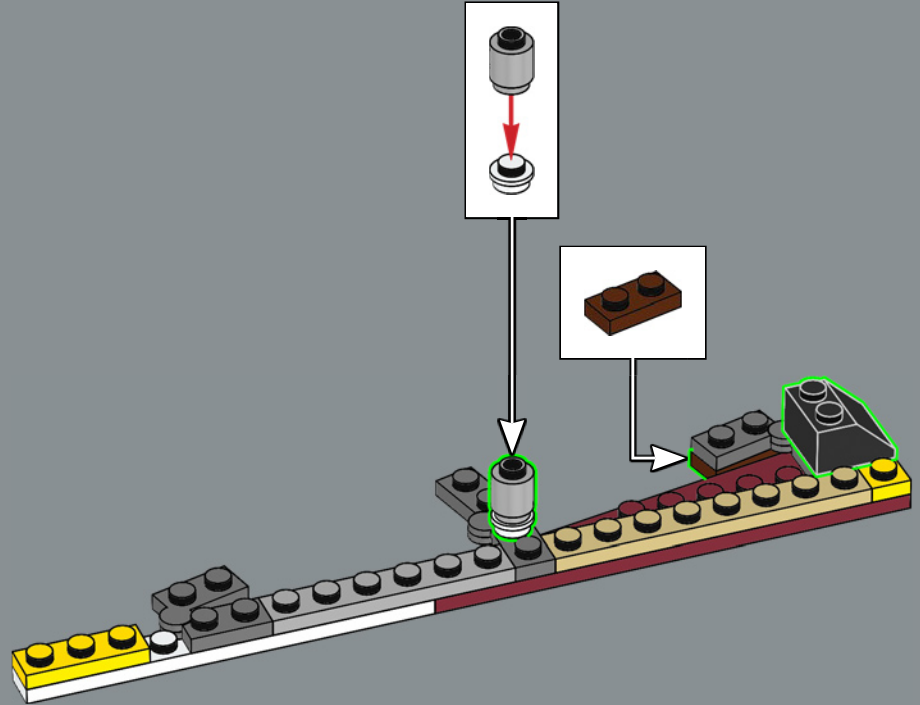



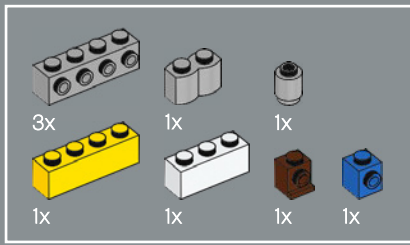

38

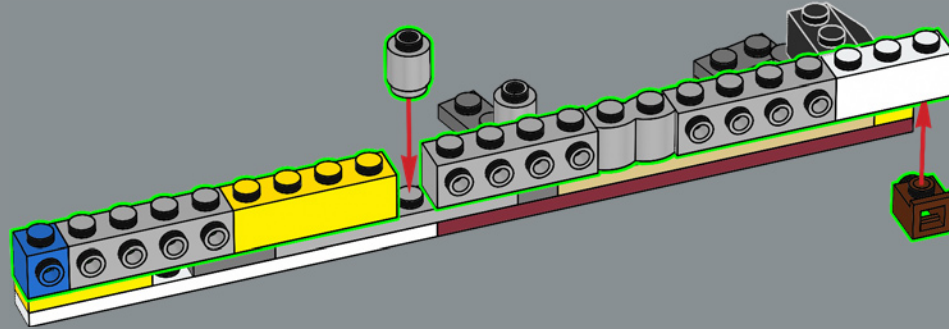

39

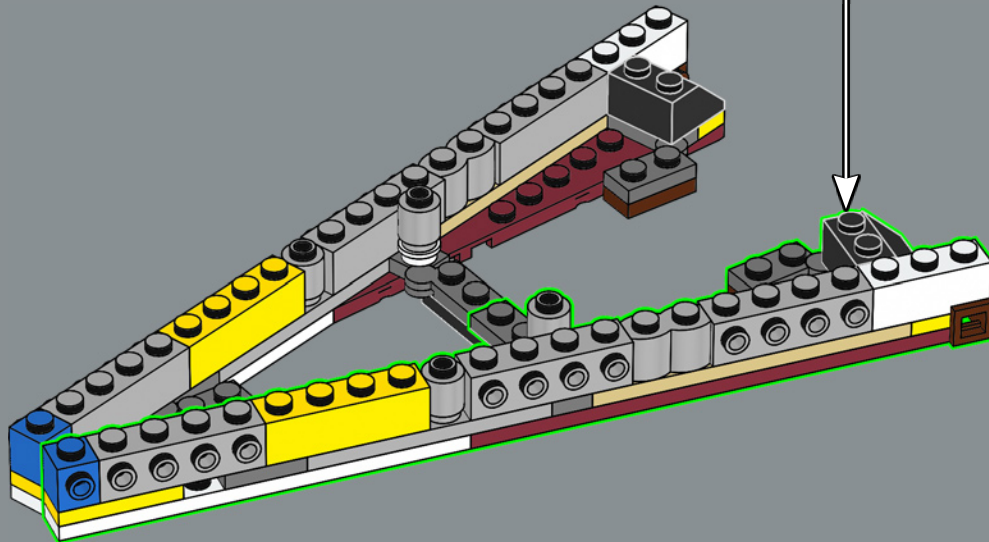

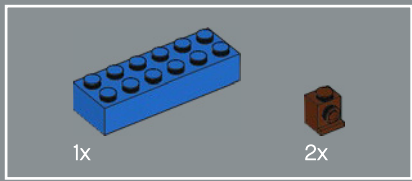

40

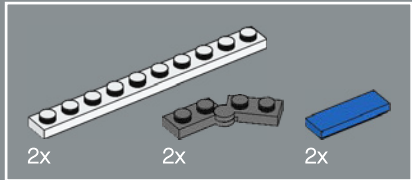
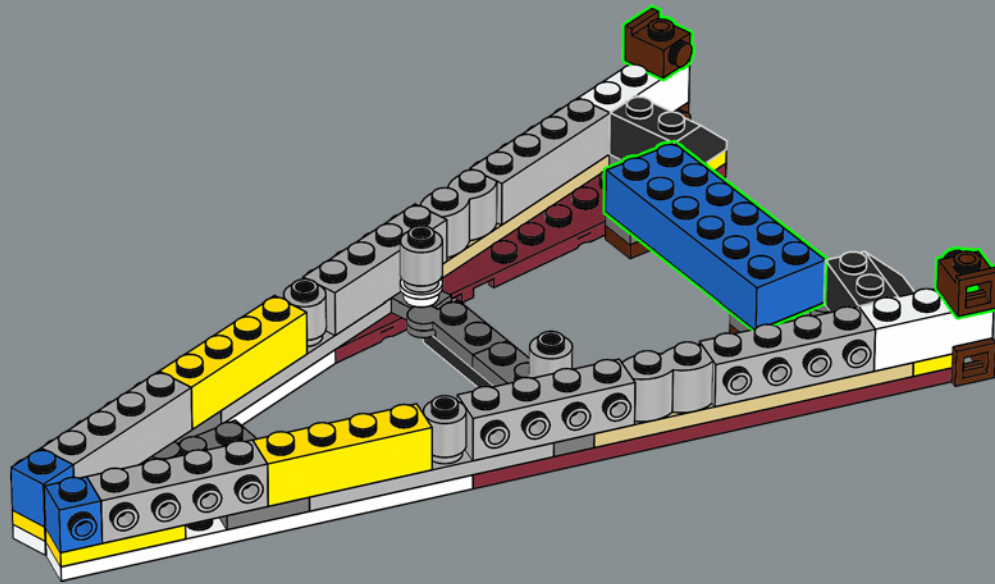

41

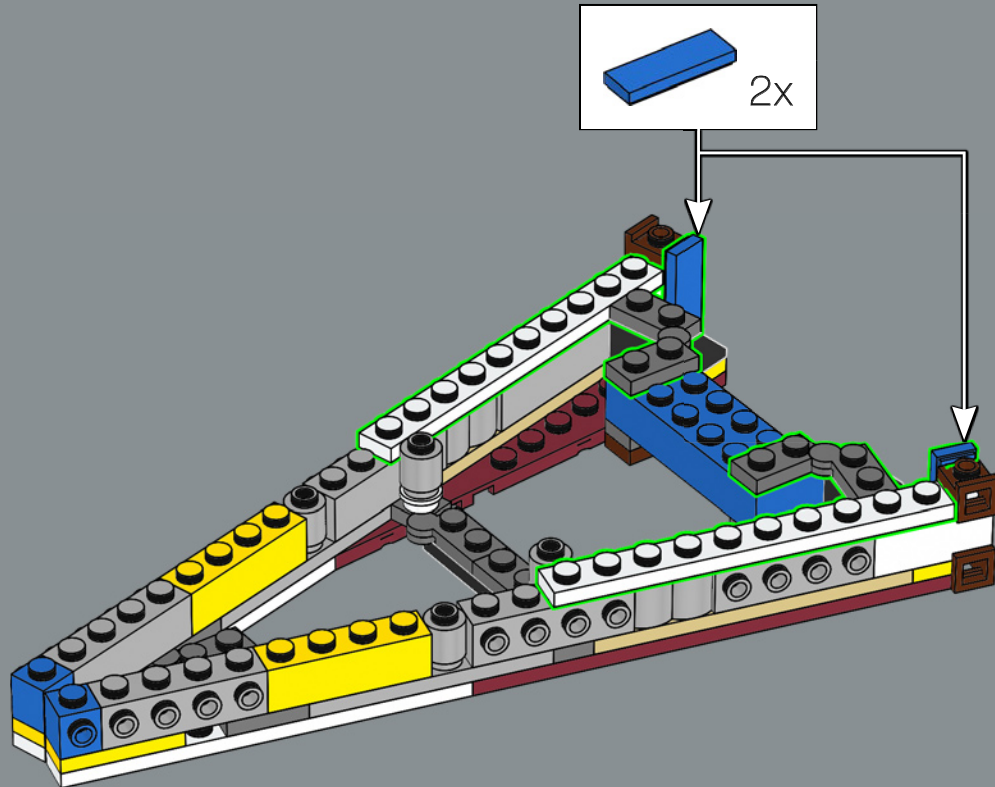
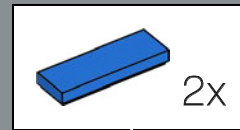

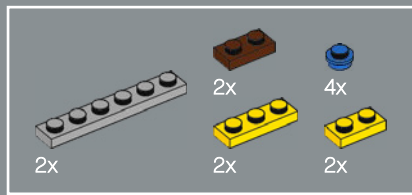

42

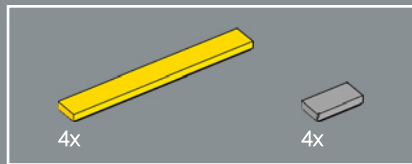
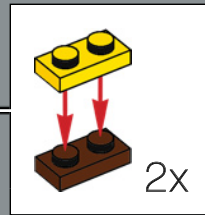
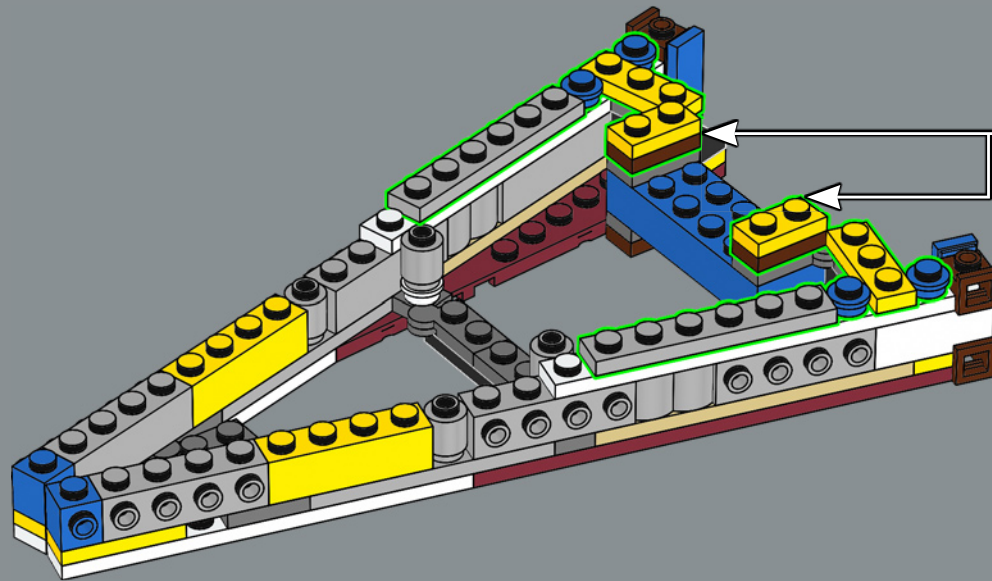

43

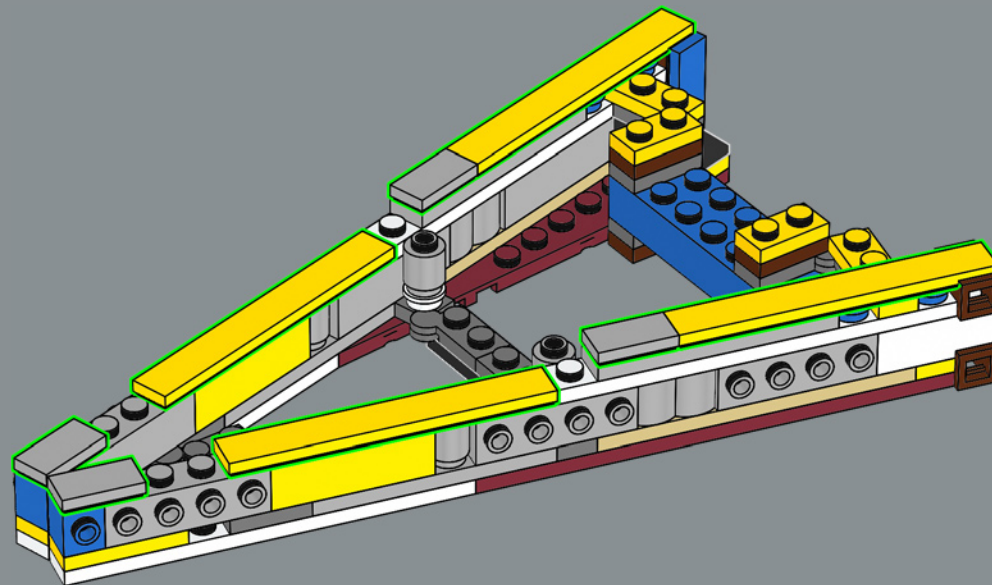

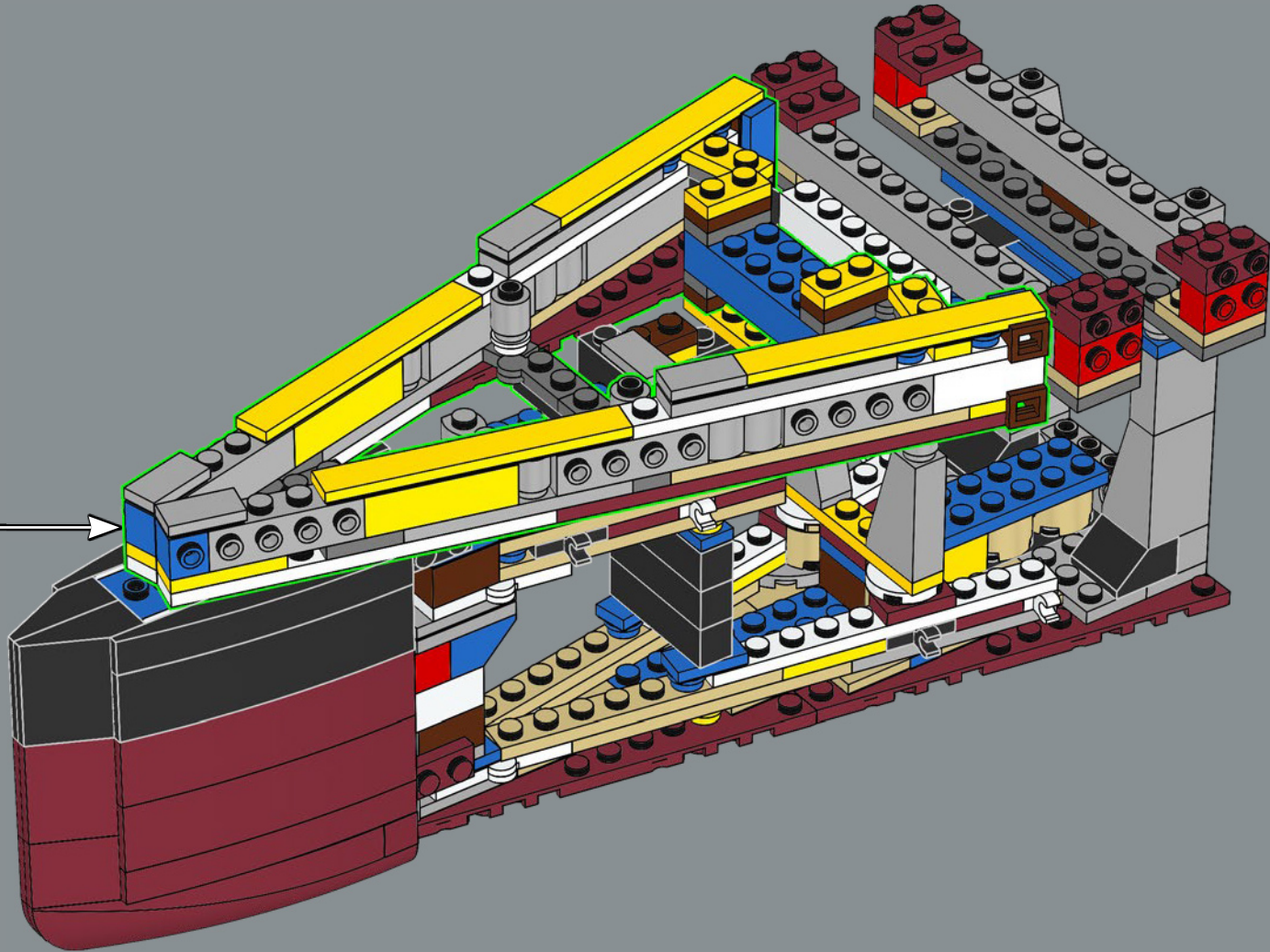

---

La construction de l'Olympic et du Titanic  
s'est déroulée quasiment en parallèle.  
La construction des deux navires a duré  
26 mois.

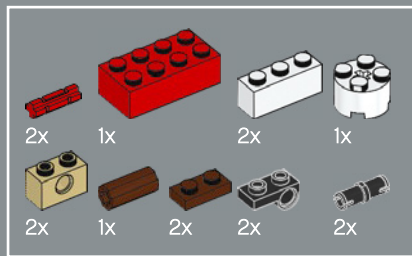

45

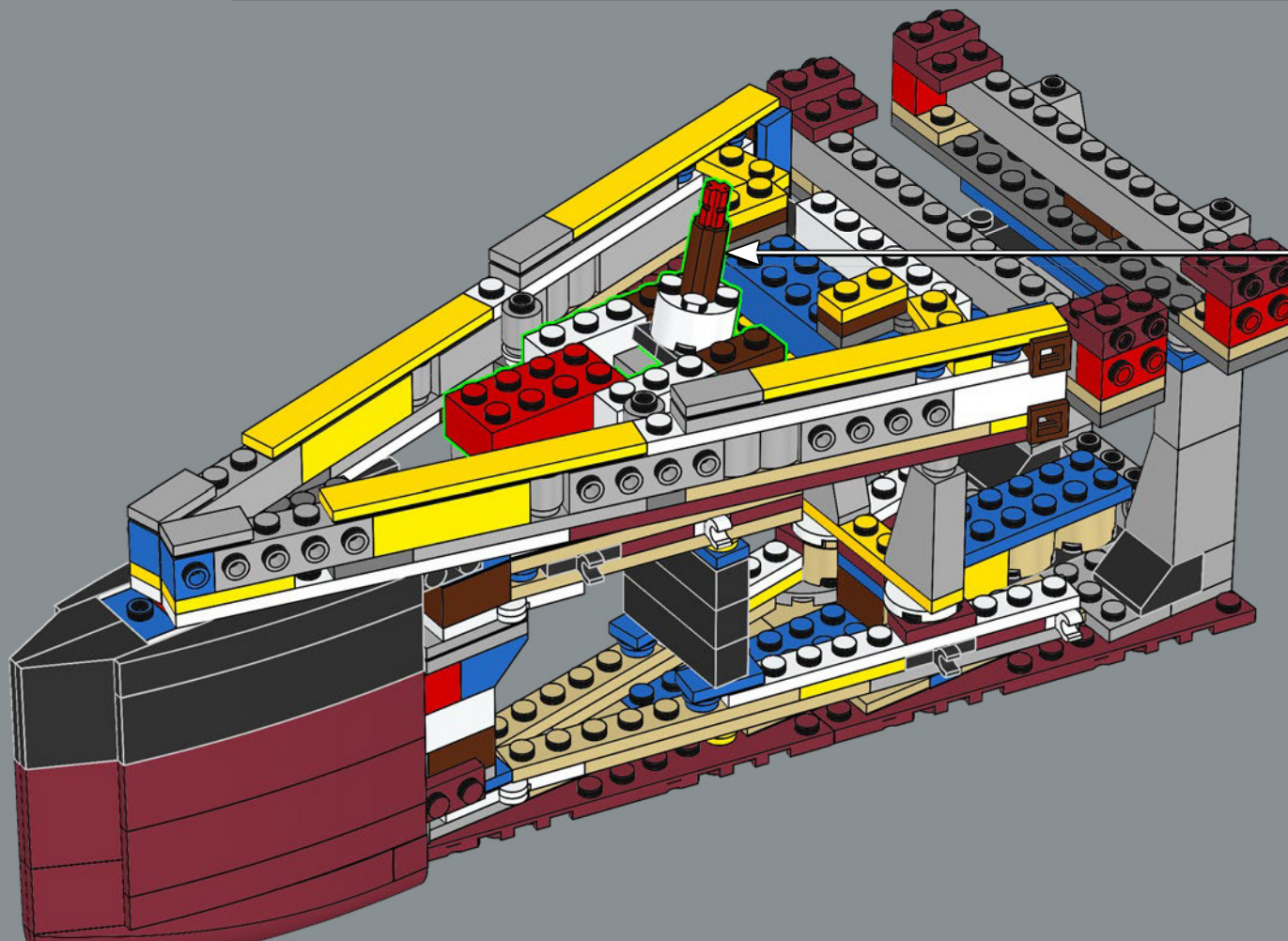
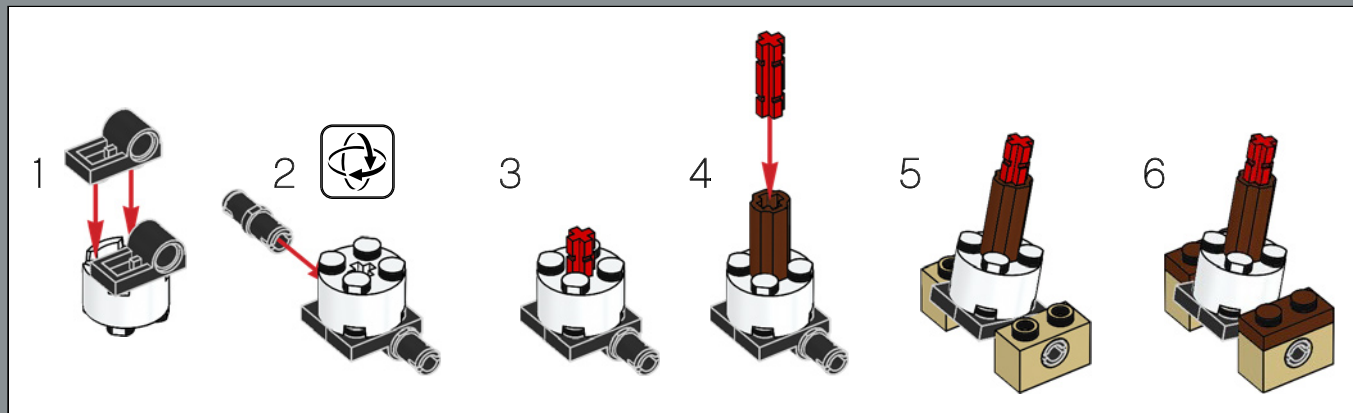

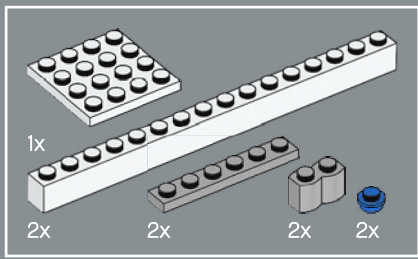

46

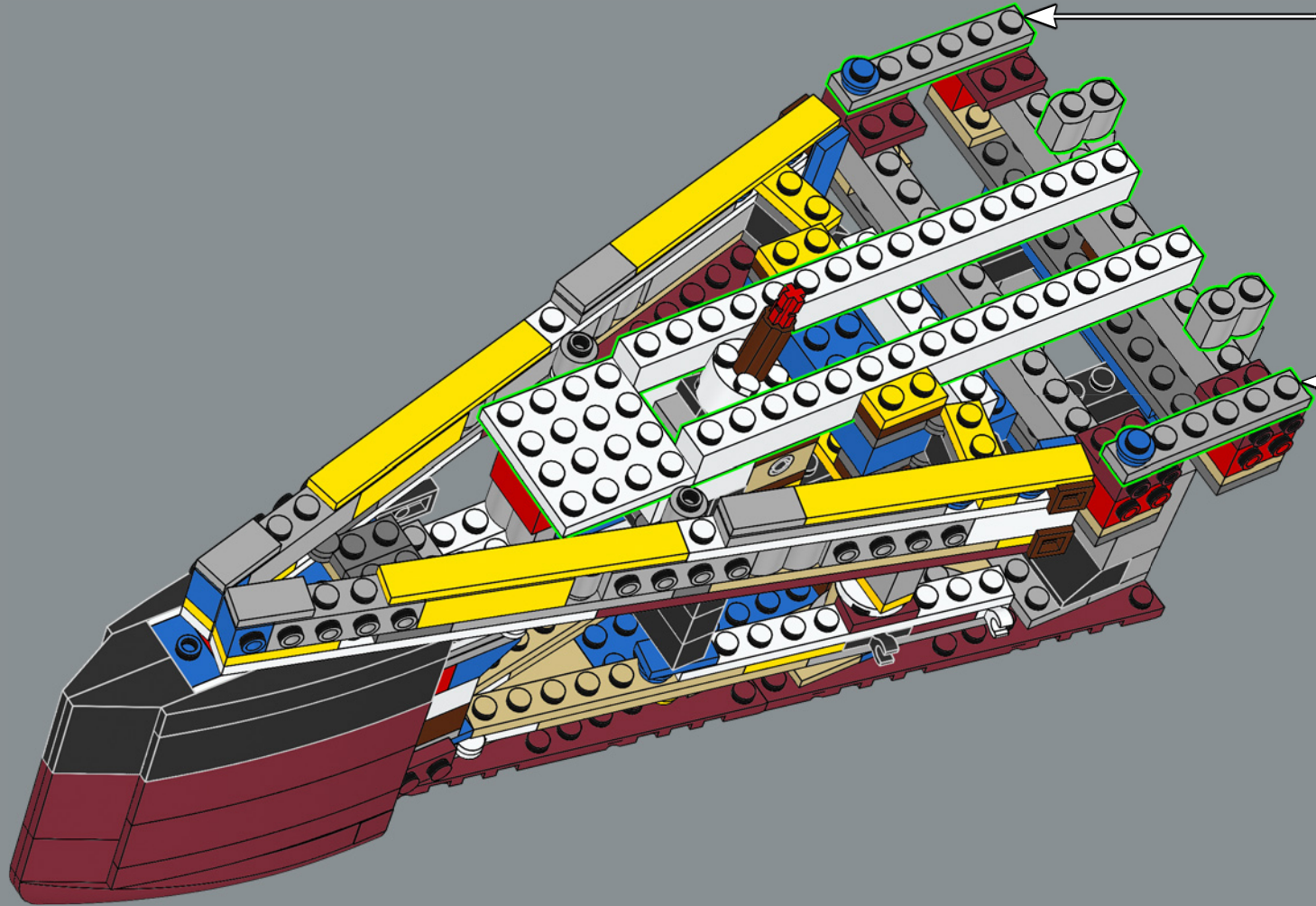
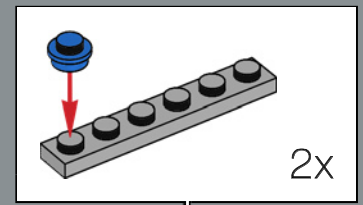

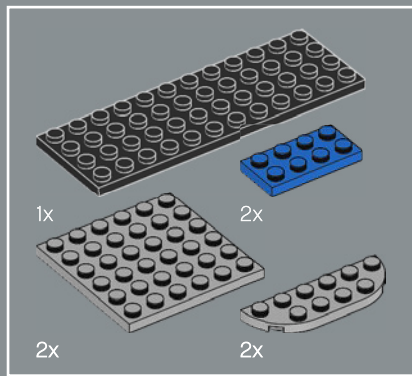

47

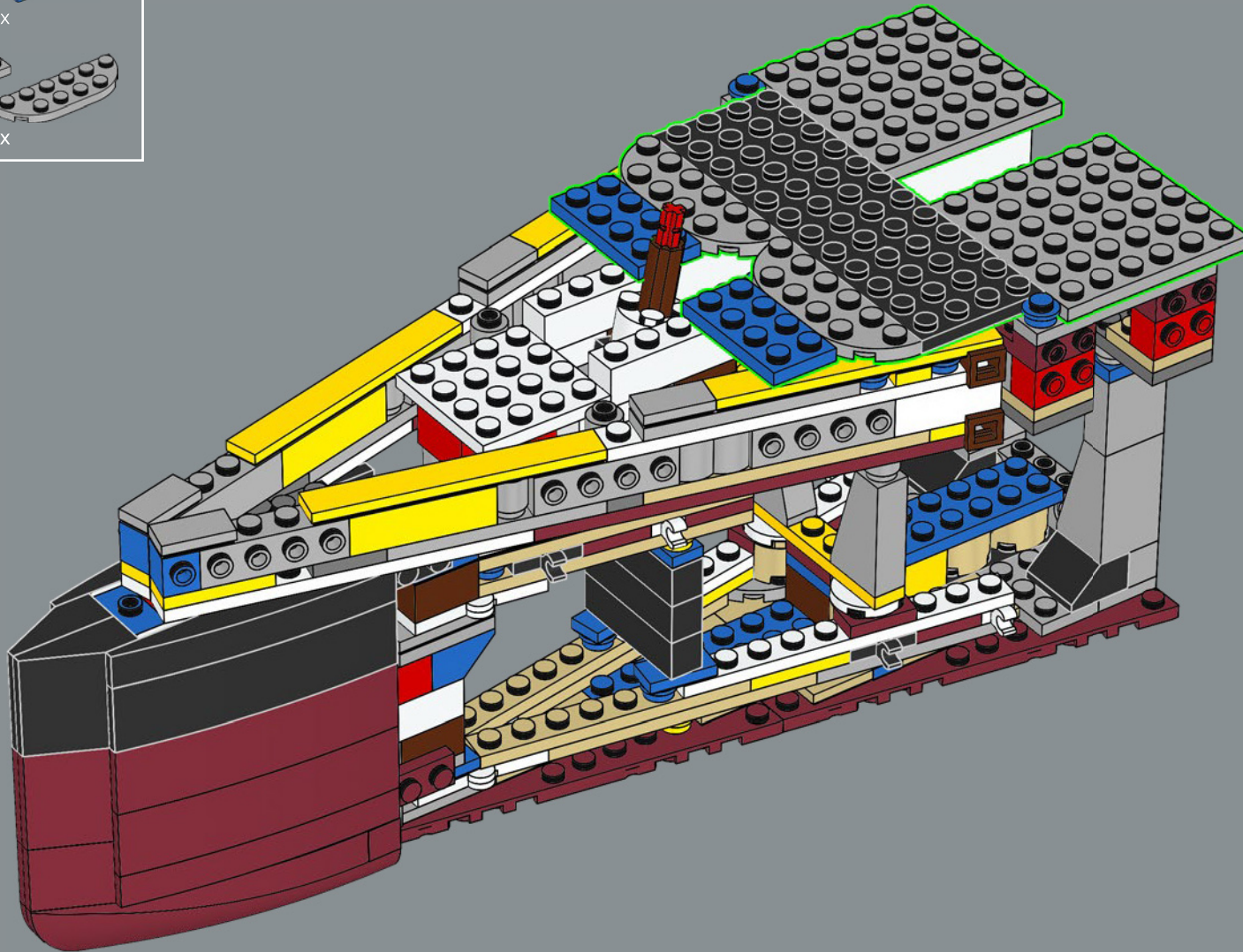

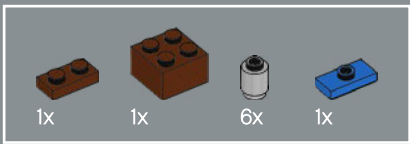

48

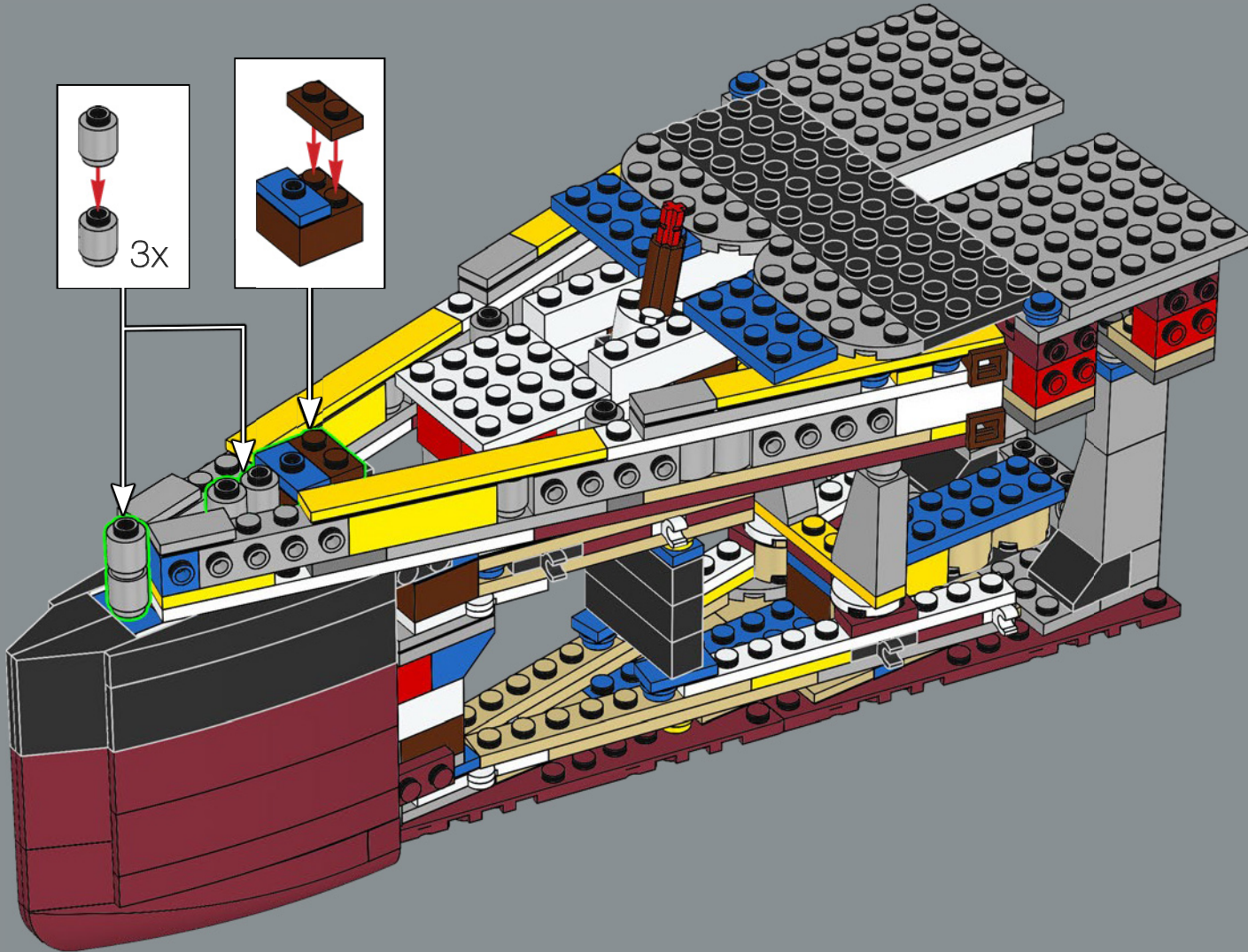



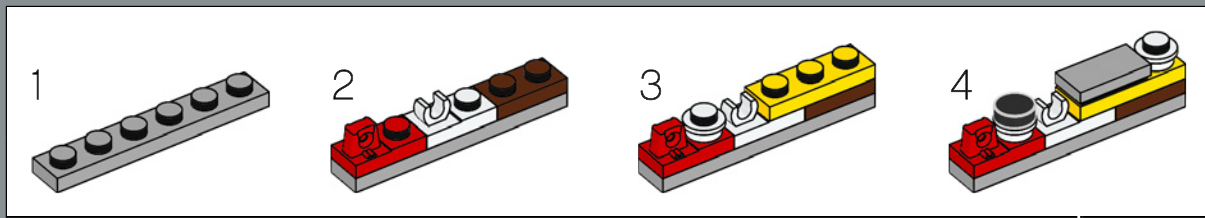
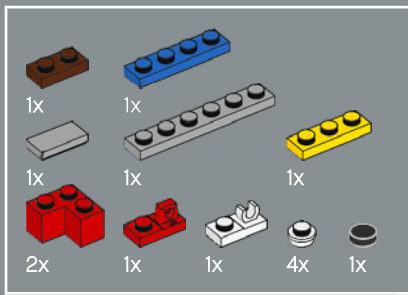

49

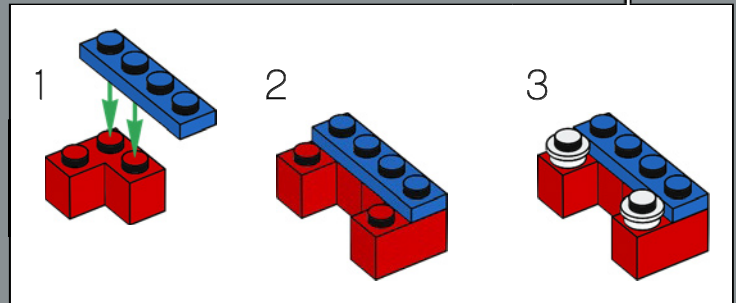
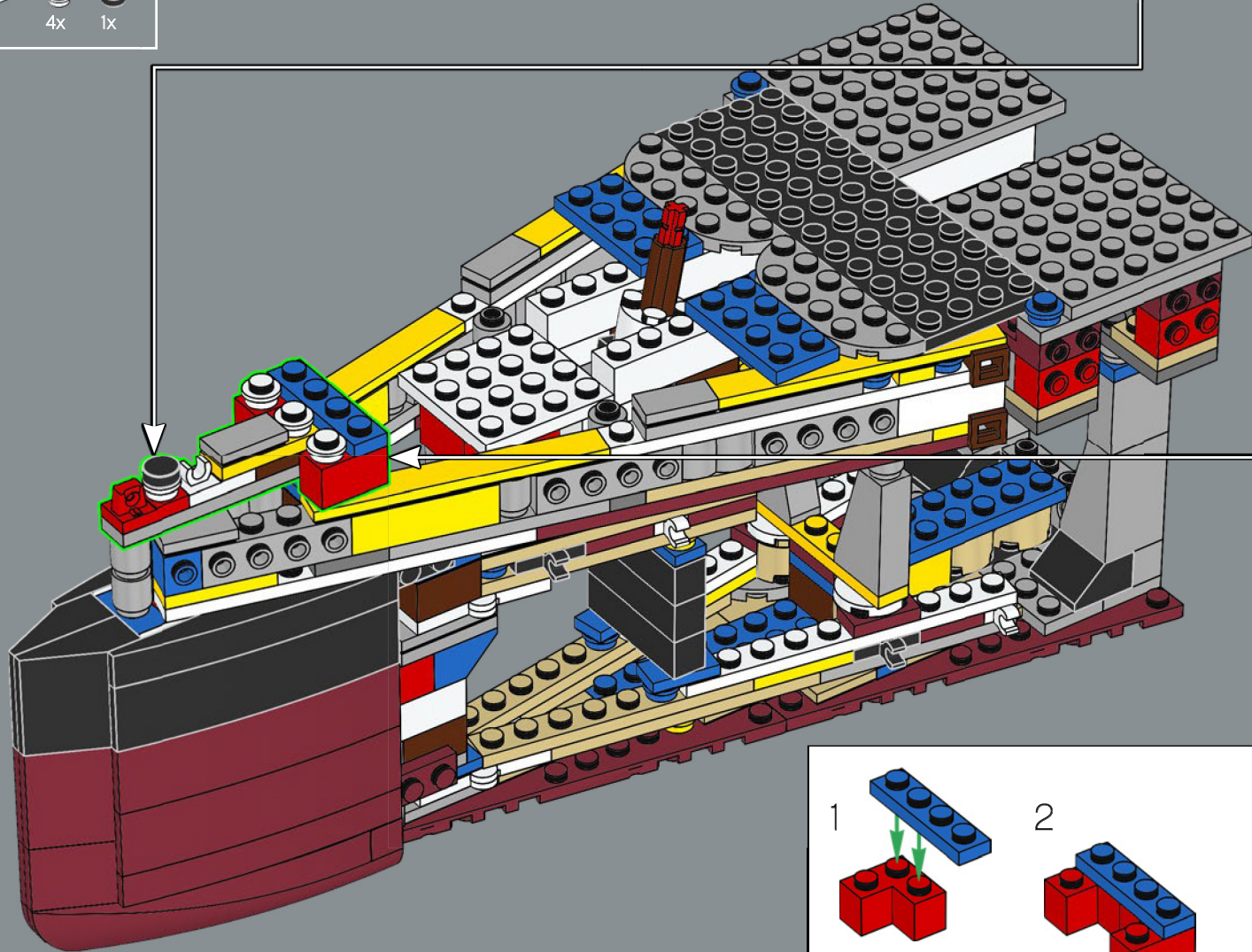

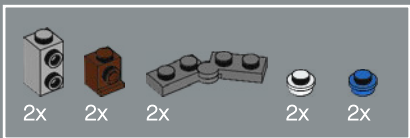

50

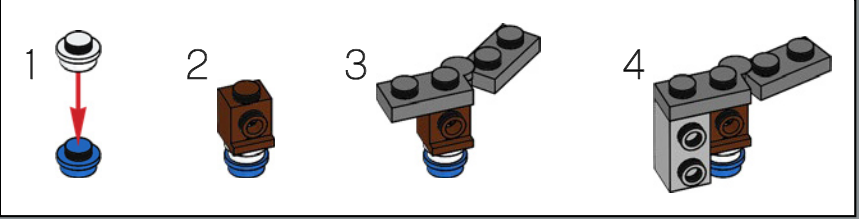
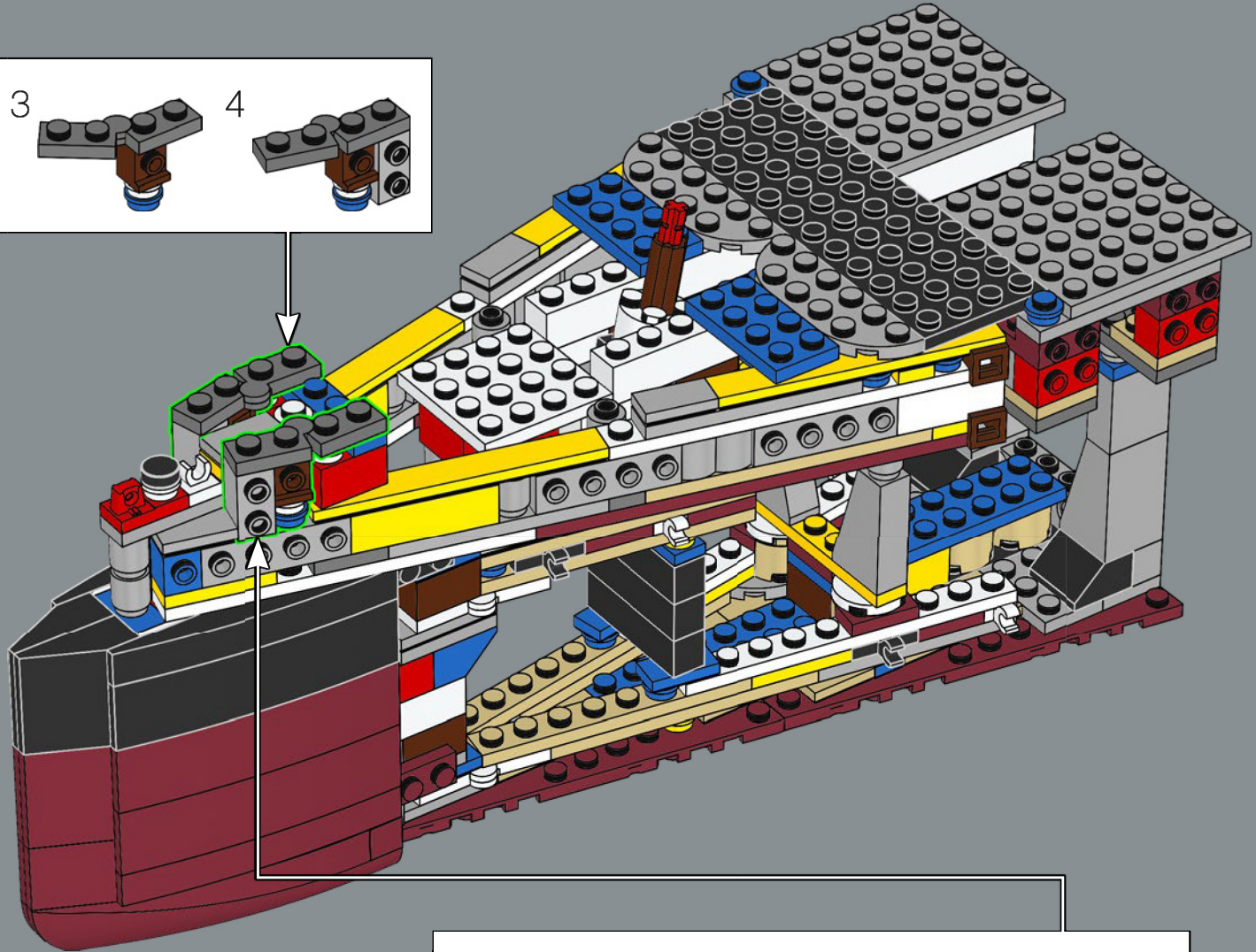
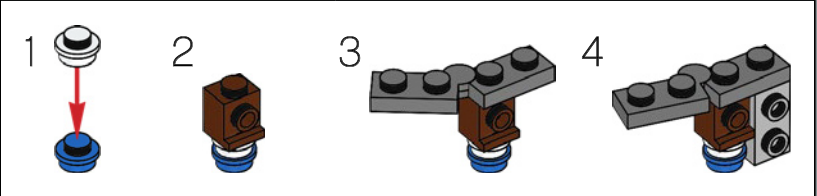

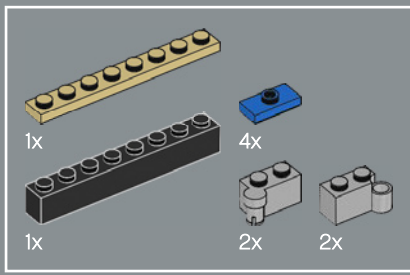

51

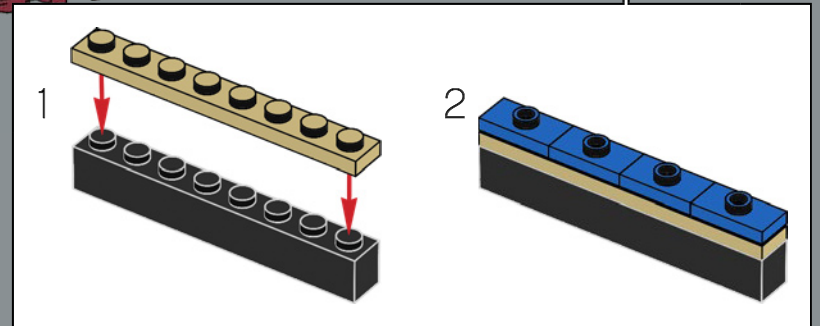
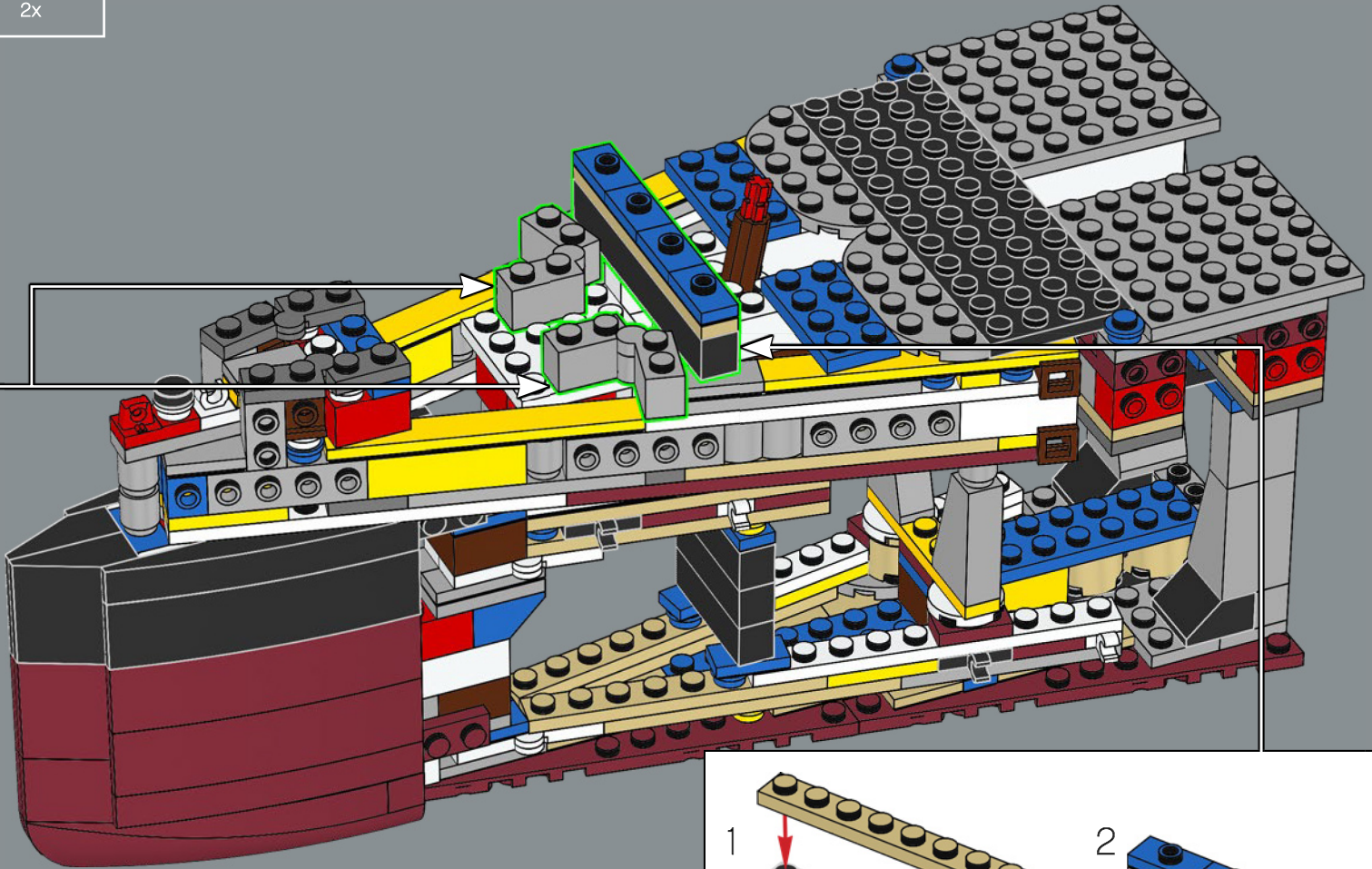
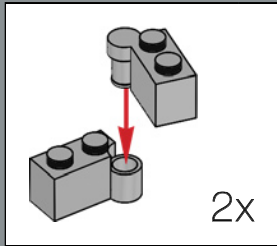

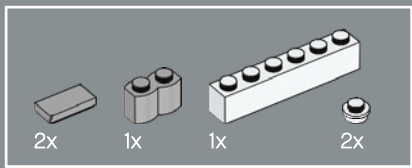

52

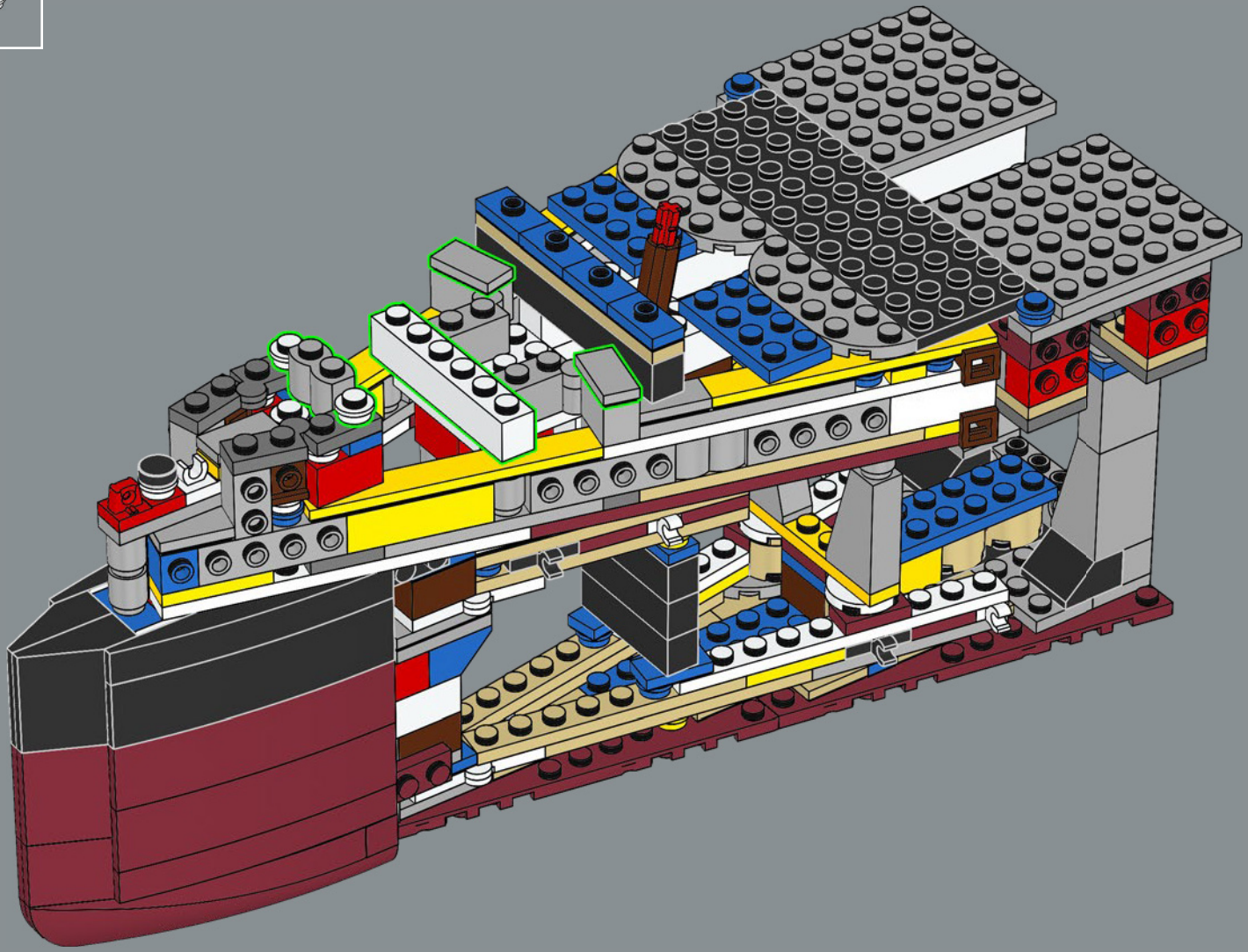

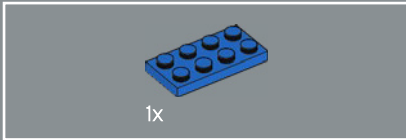
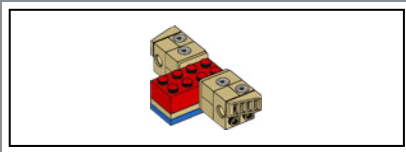

1x

53

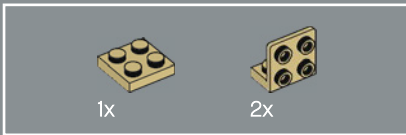
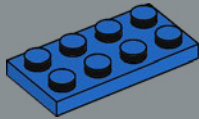

1x

2x

54

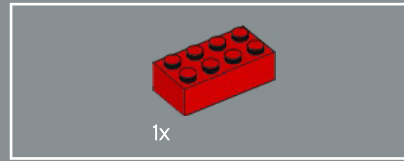
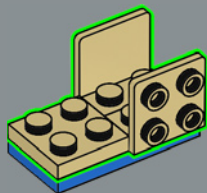

1x

55

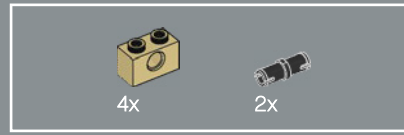
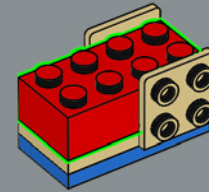

4x

2x

56

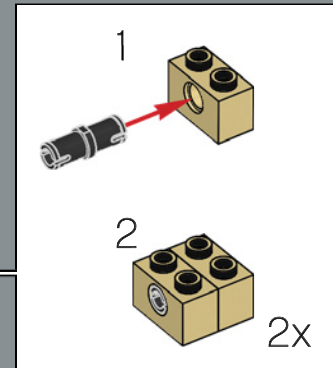

1

2

2x

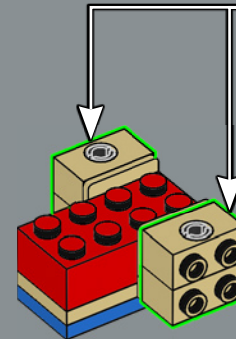

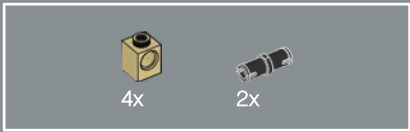

57

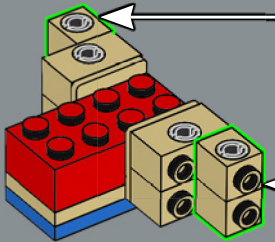
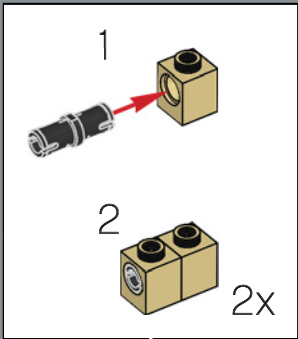

59

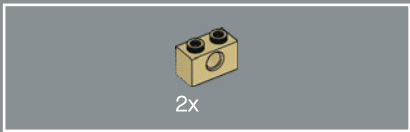
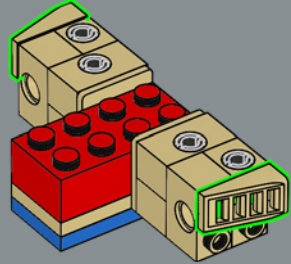

58

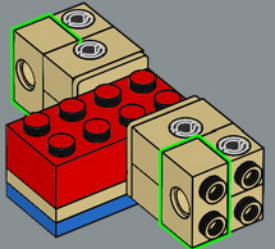

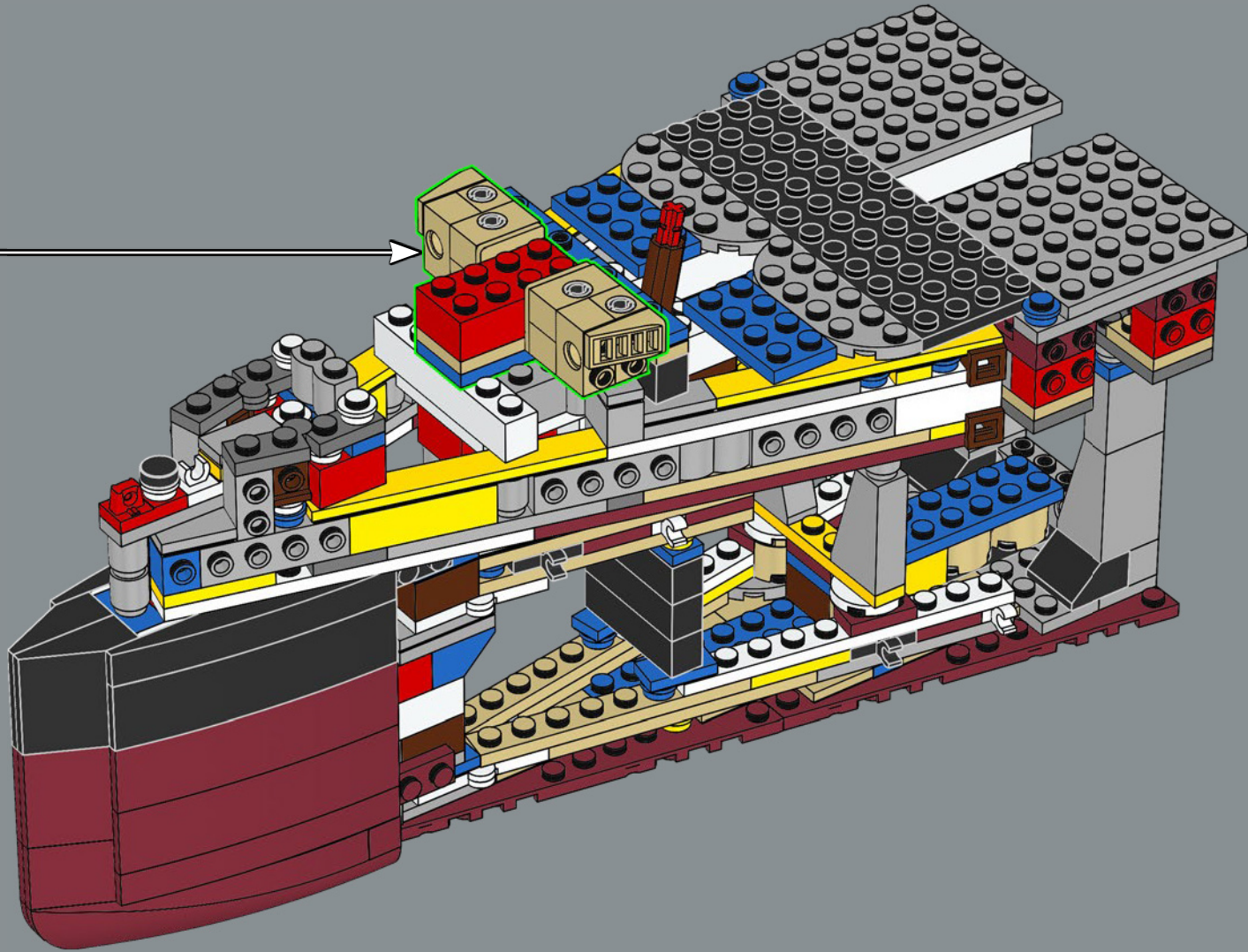

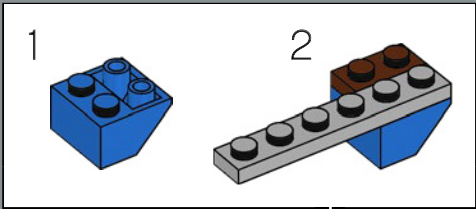
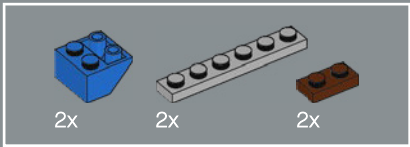

61

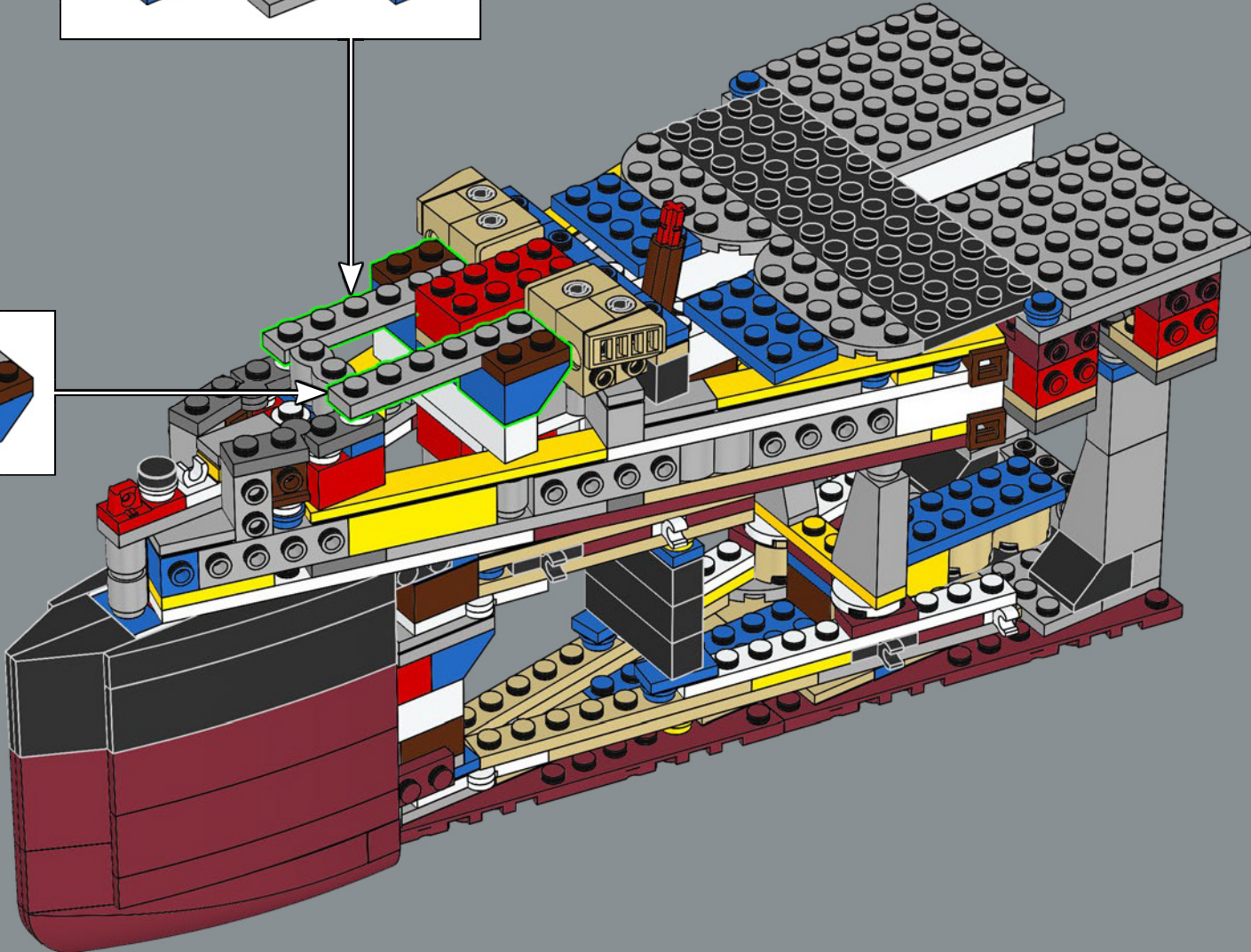
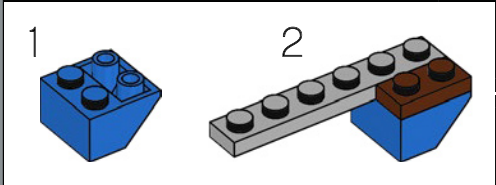



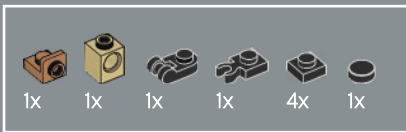

62

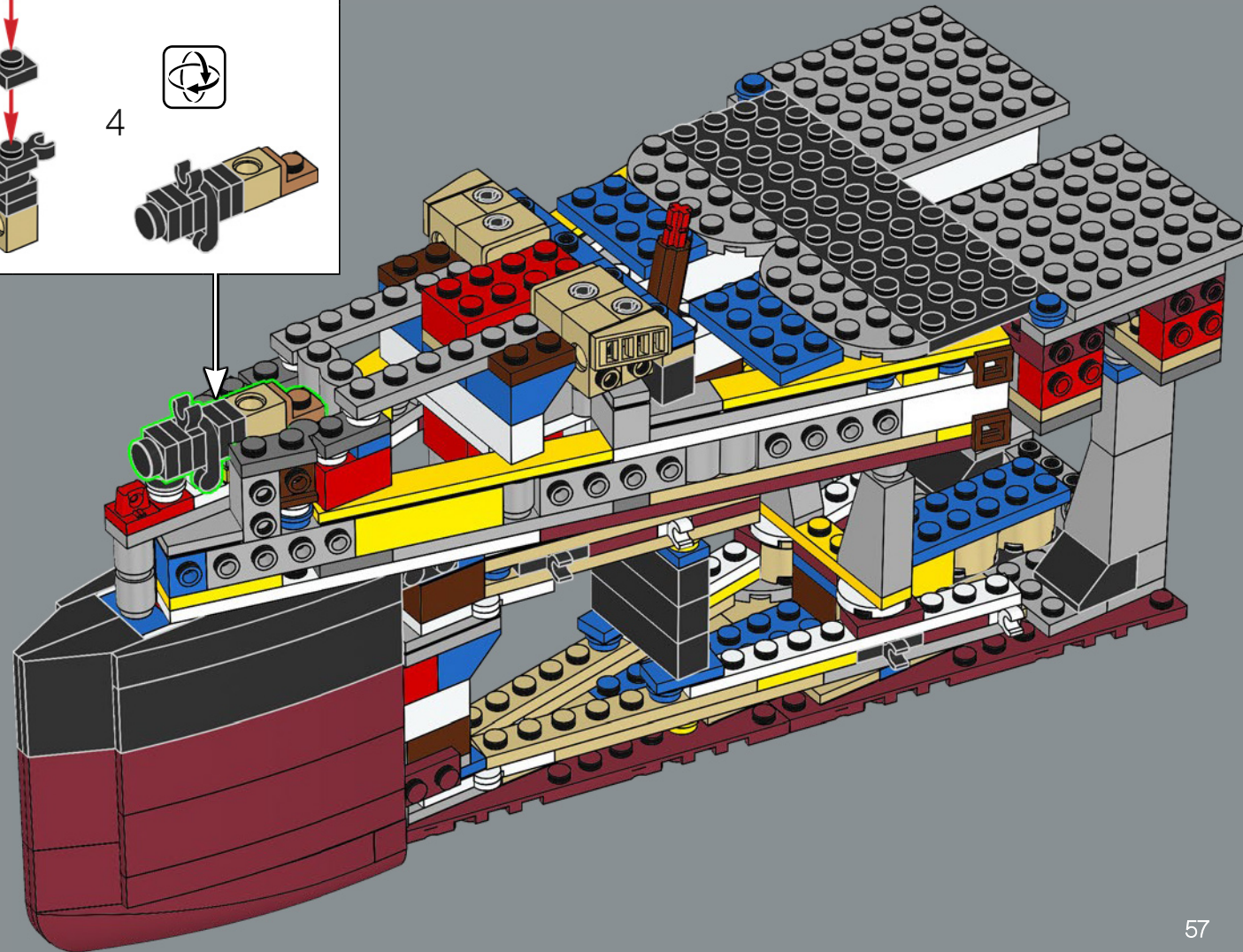
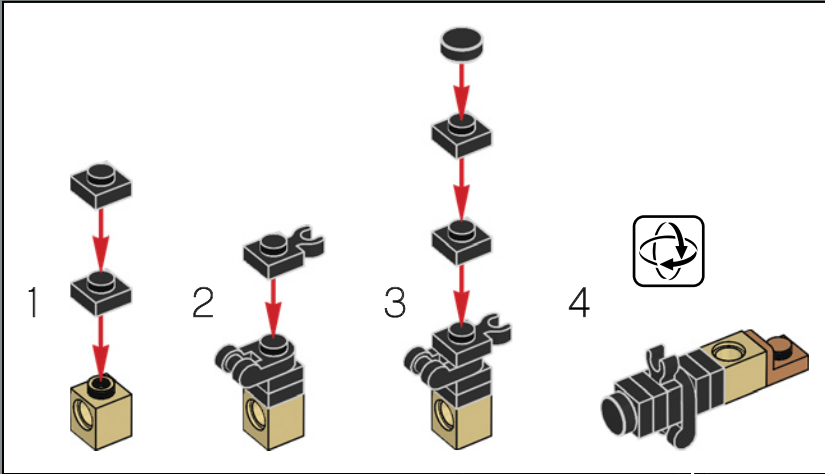

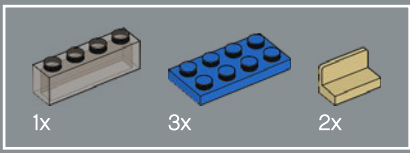

63

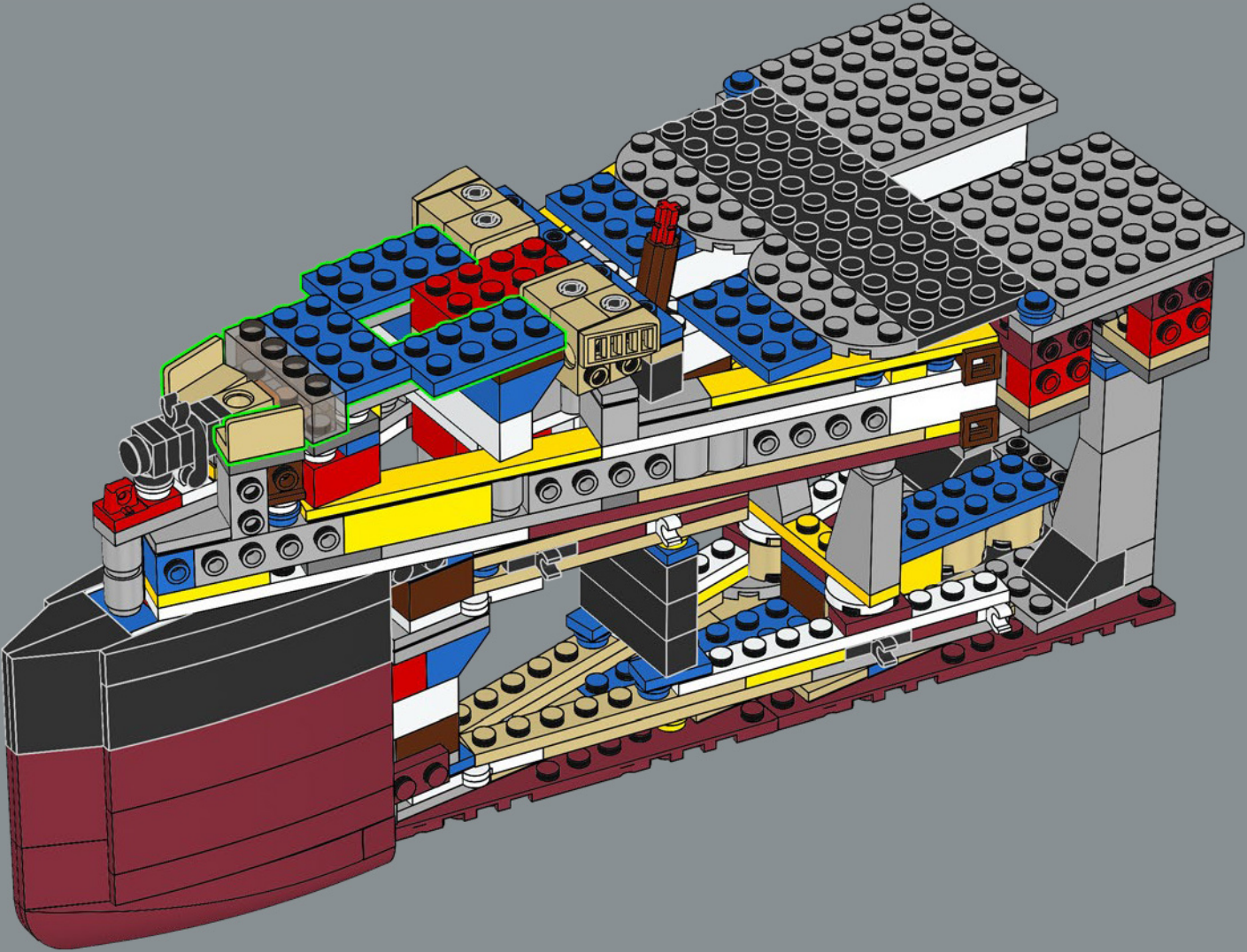

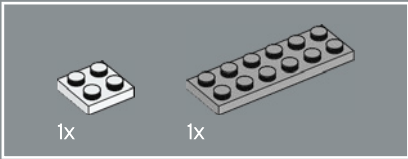
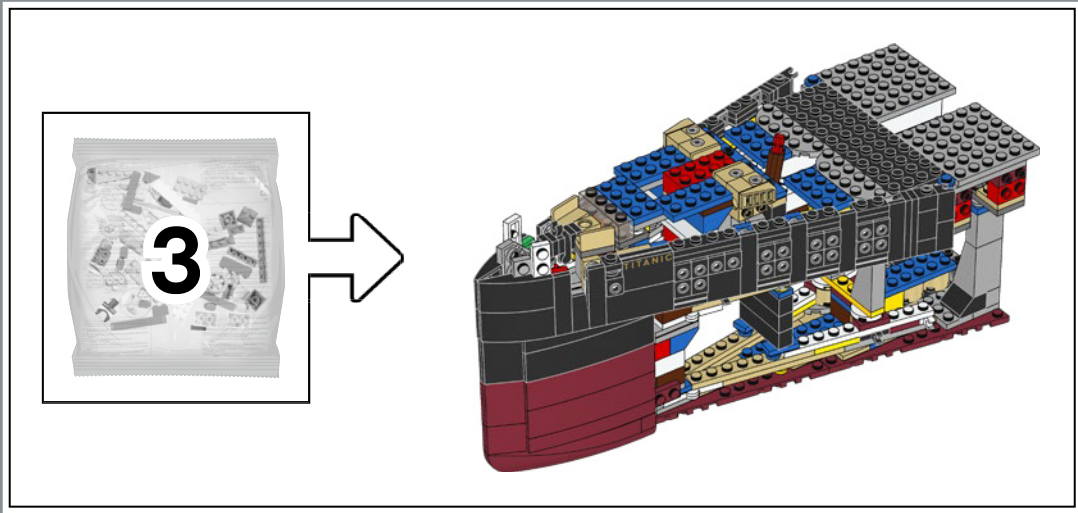

65

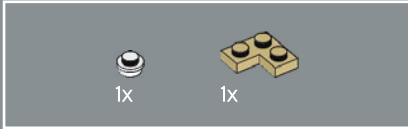
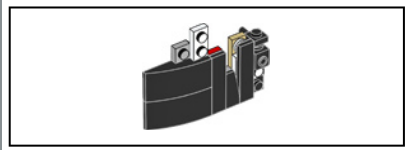

64

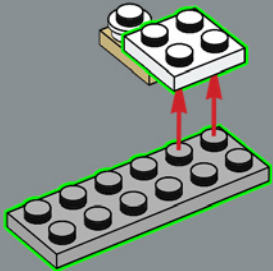
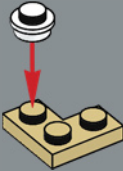

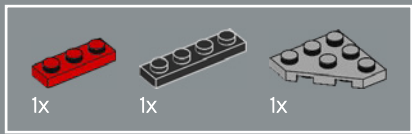

66

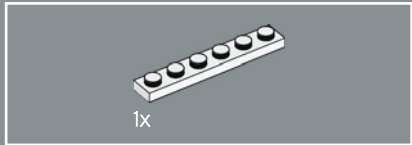
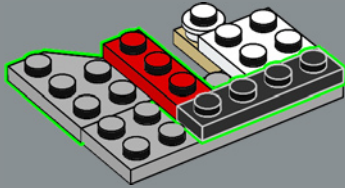

67

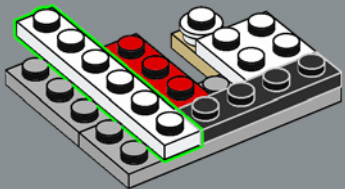

68

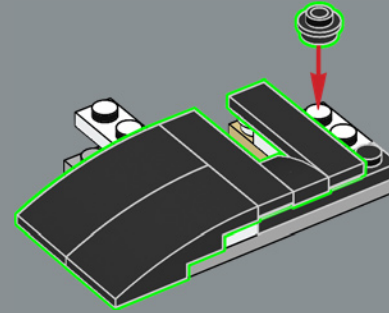

69

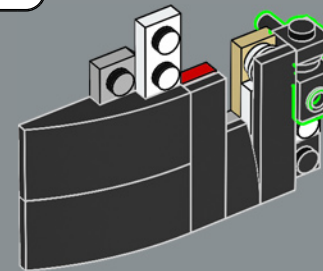
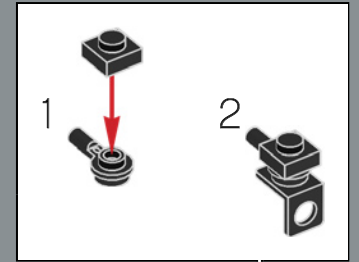

70

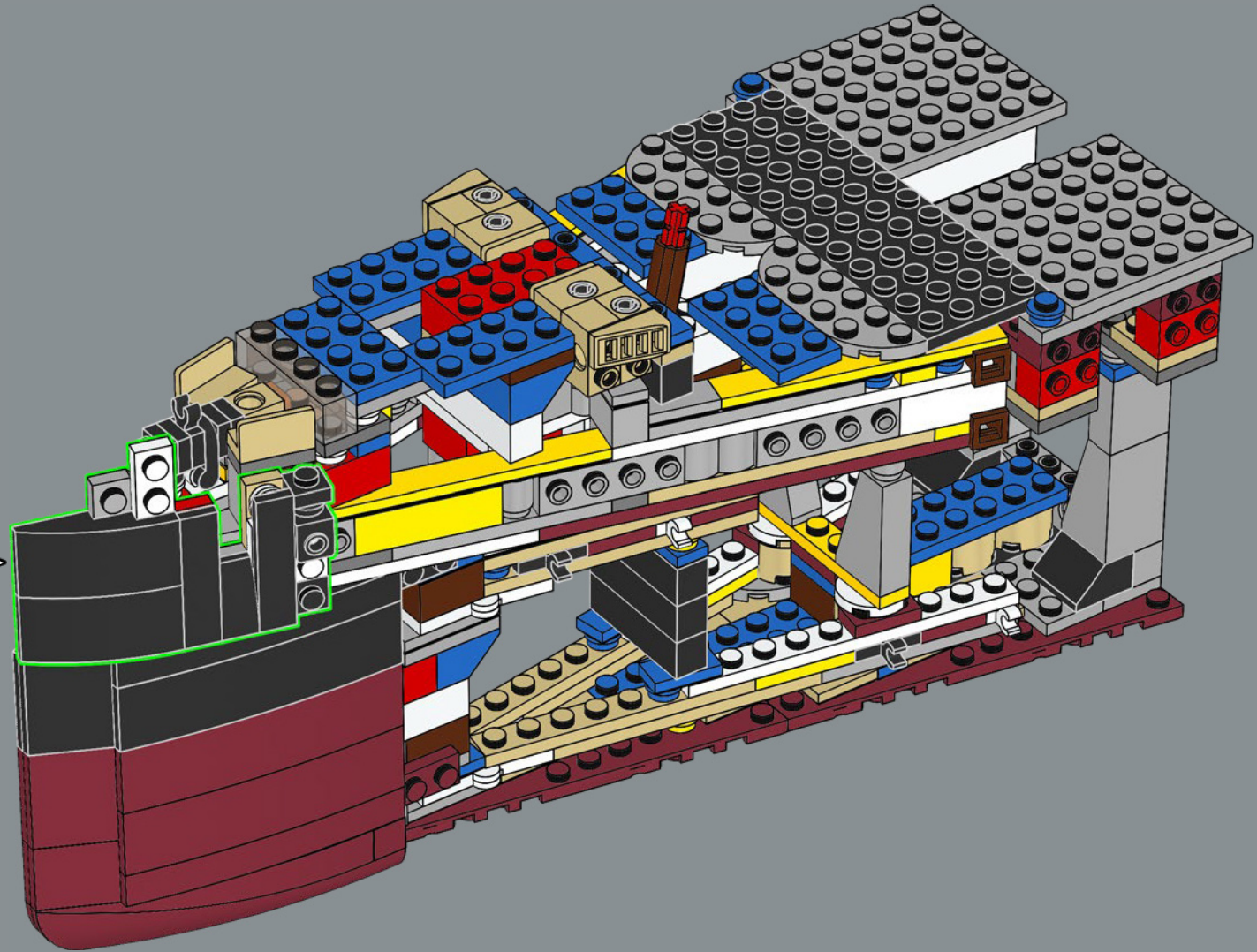

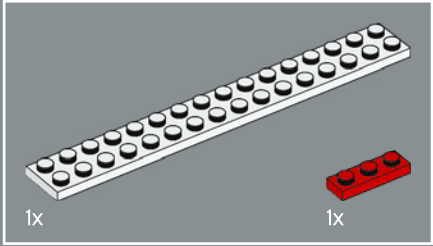
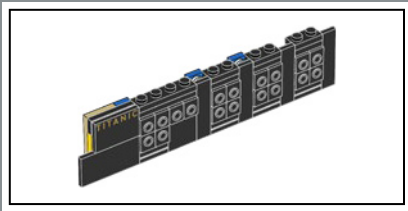

71

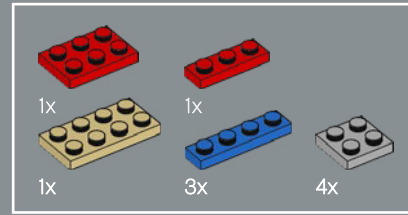
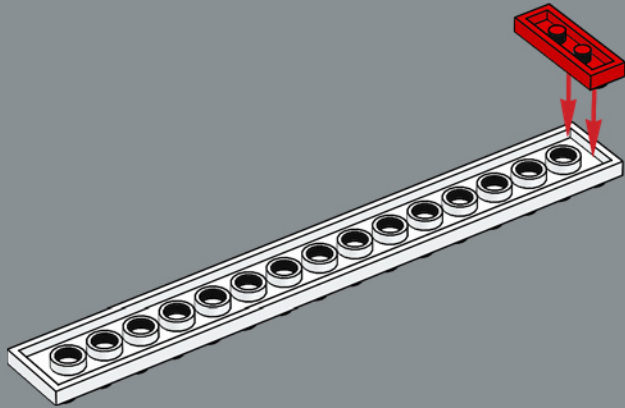

72

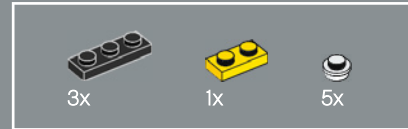
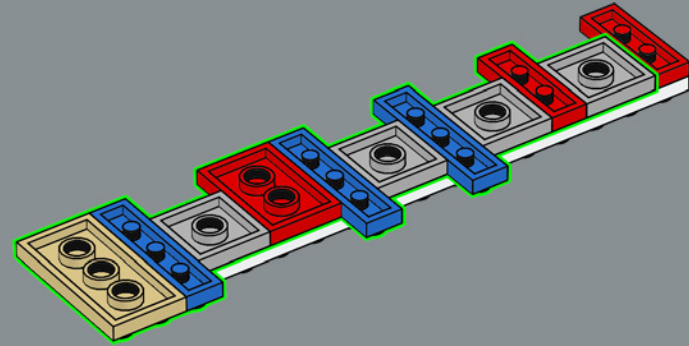

73

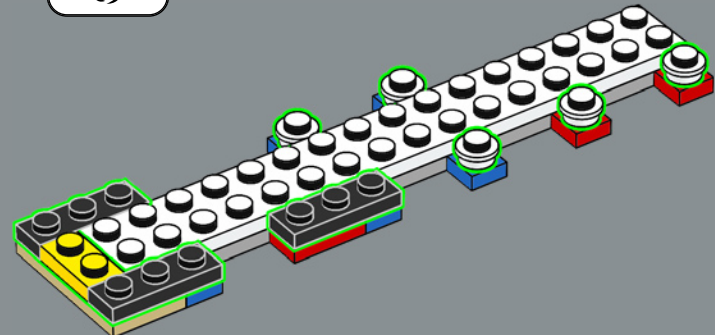

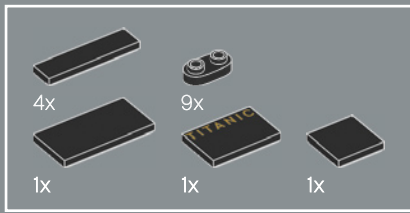

74

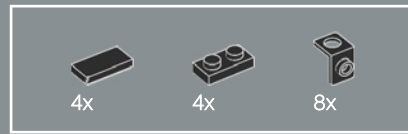
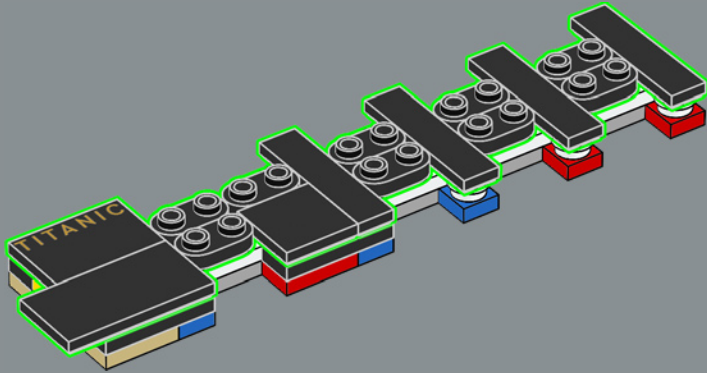

75

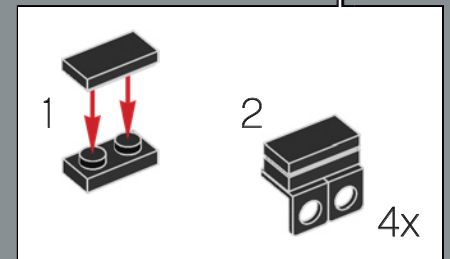
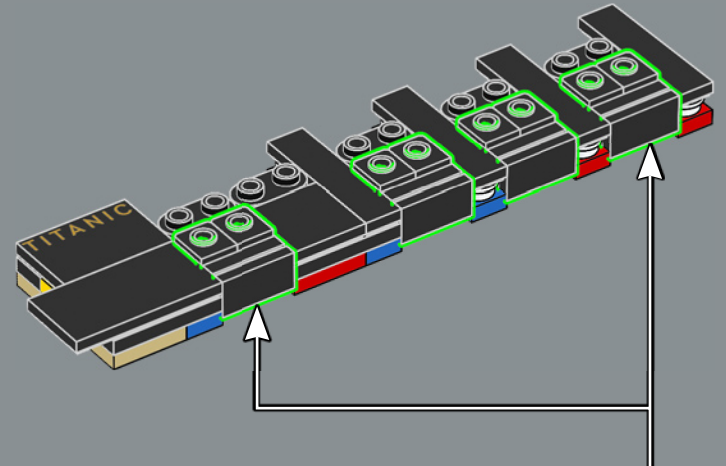

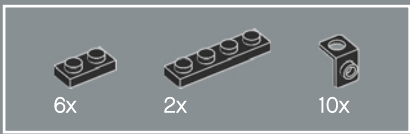

76

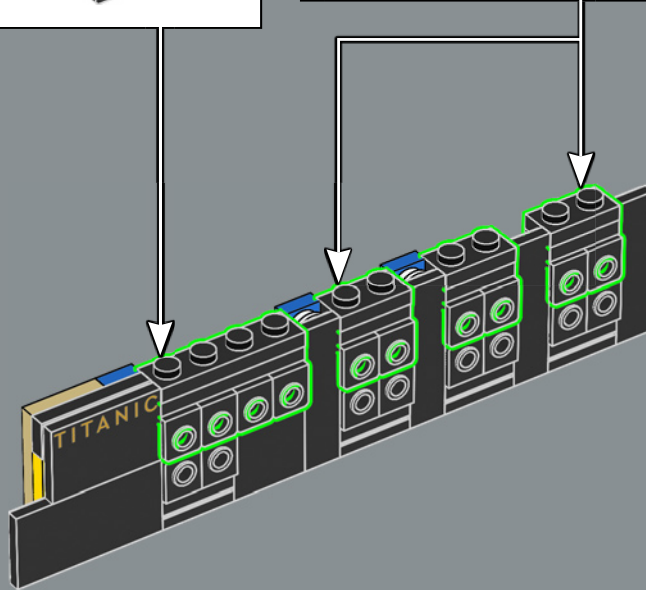
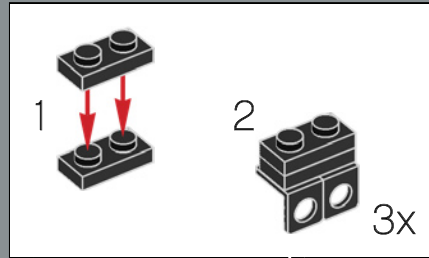
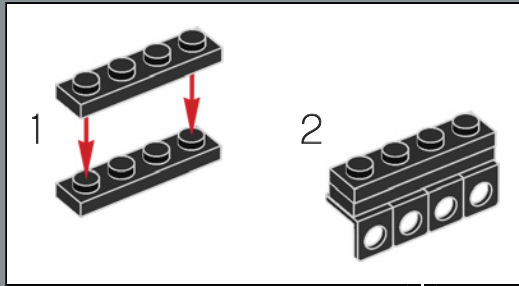



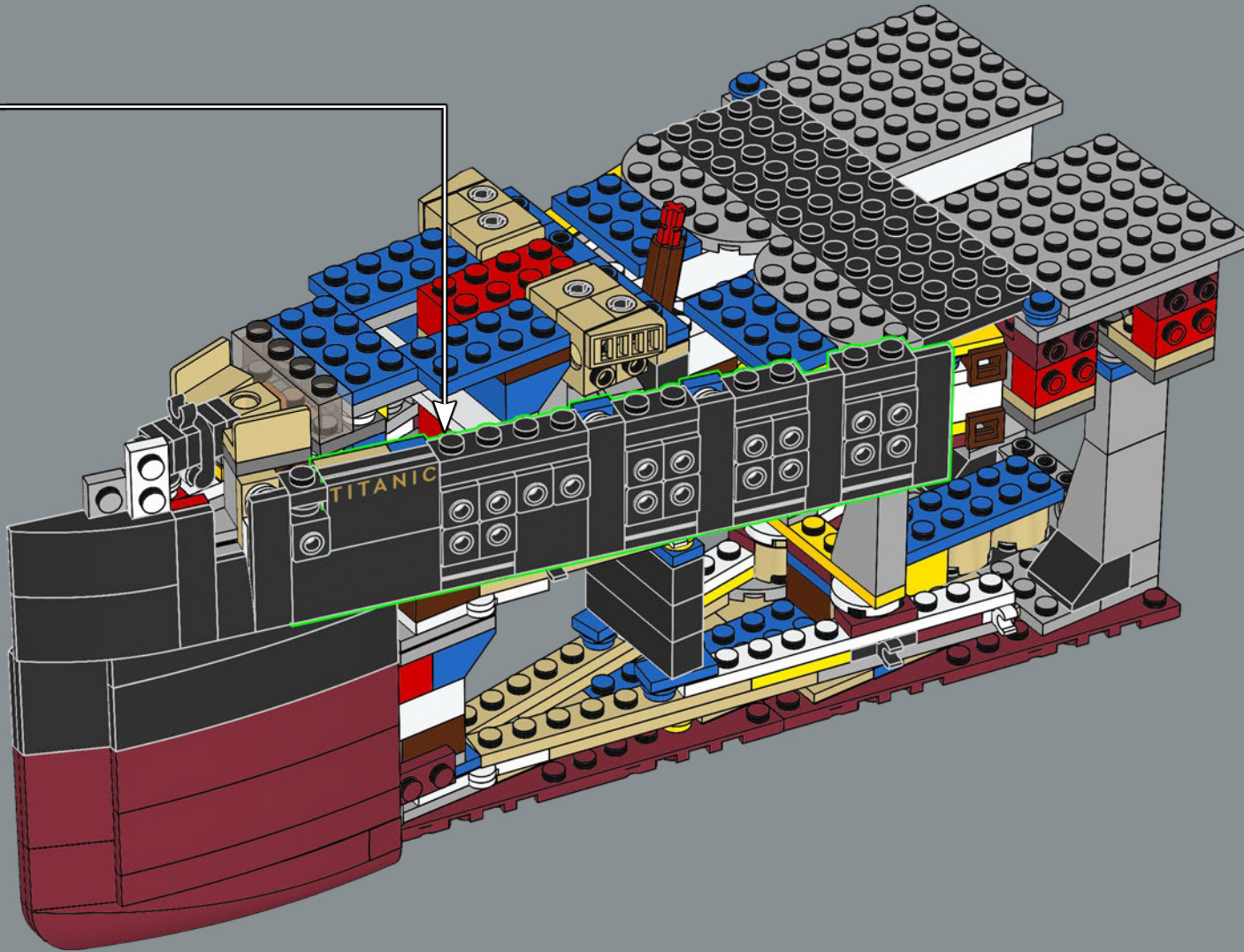

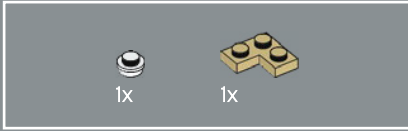
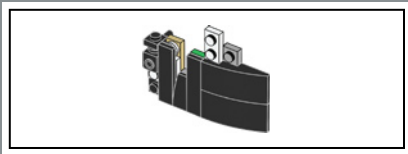

78

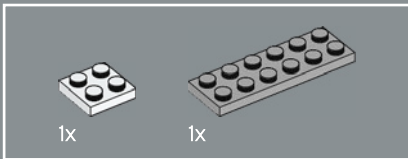
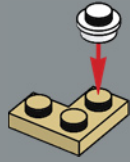

79

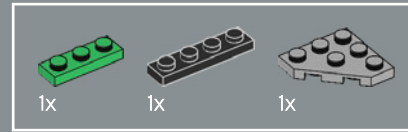
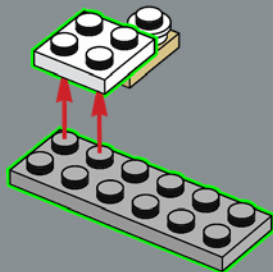

80

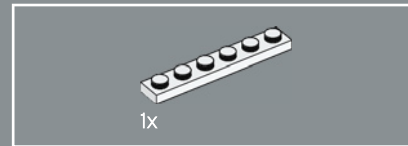
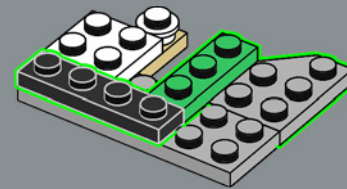

81

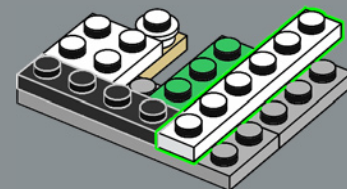



82

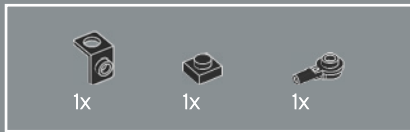
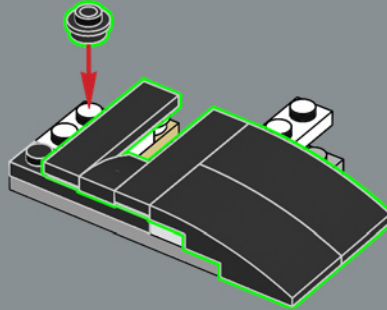

83

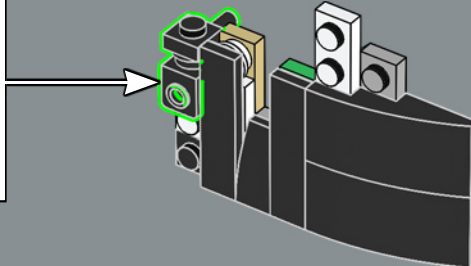
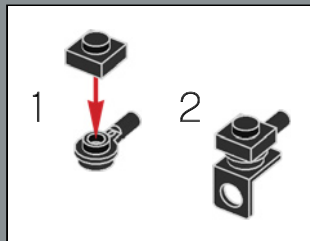

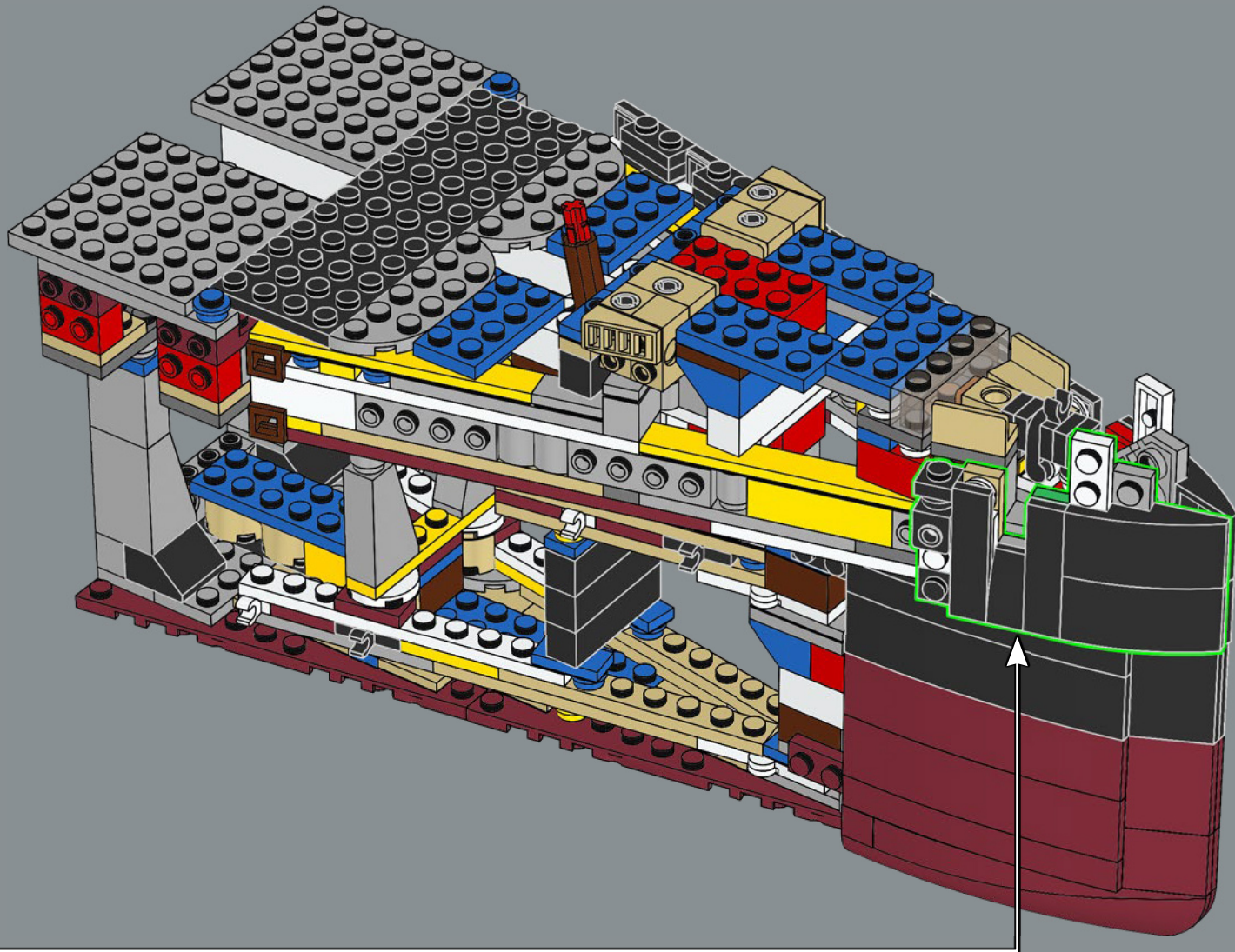

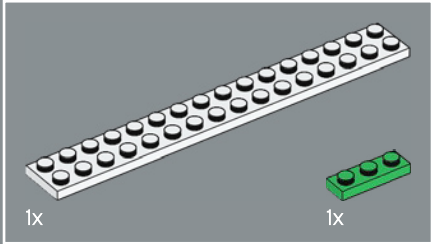
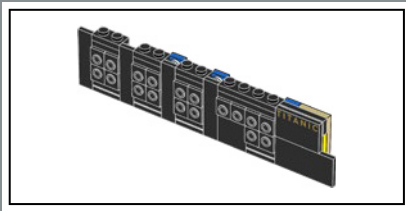

85

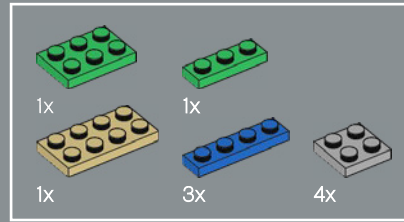
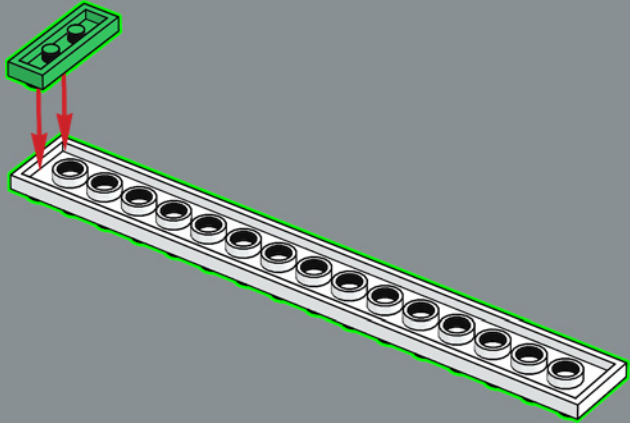

86

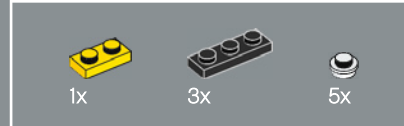
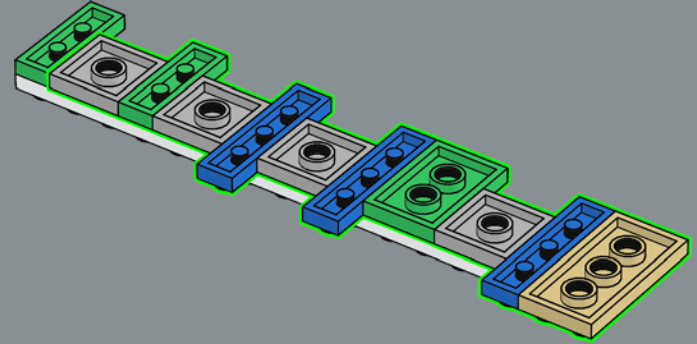

87

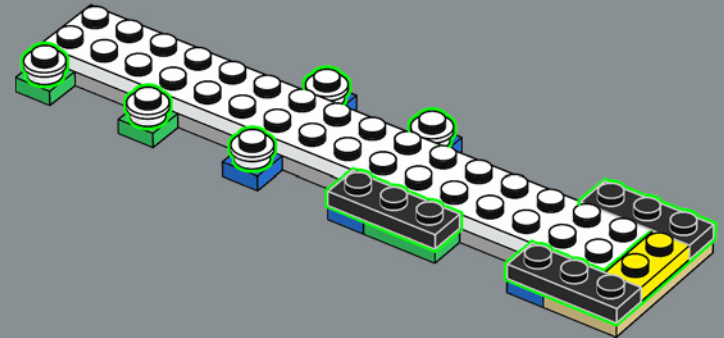

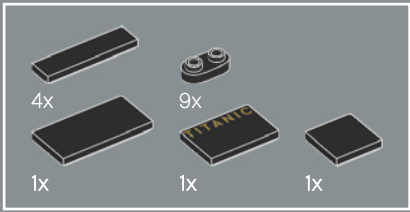

88

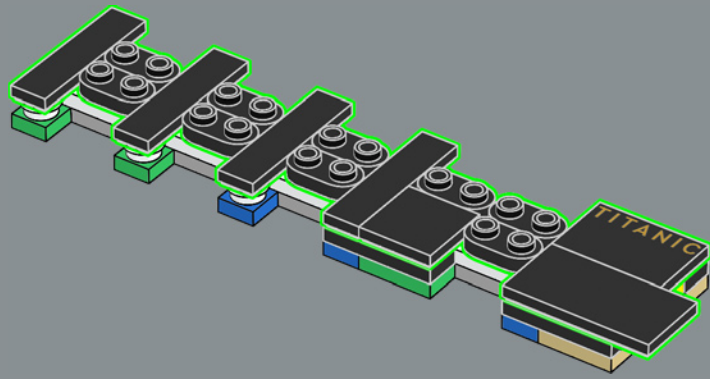

89

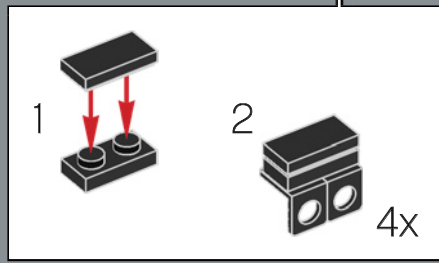
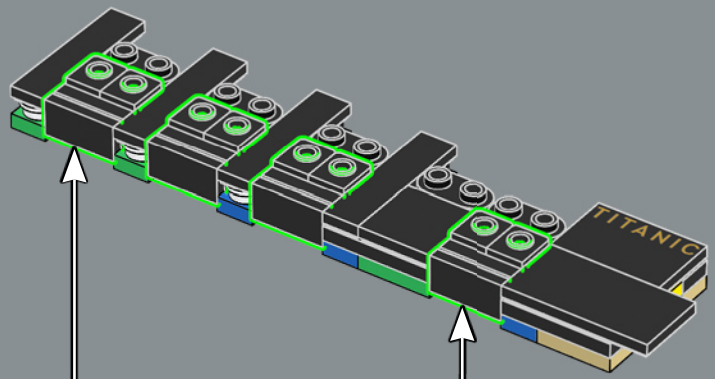

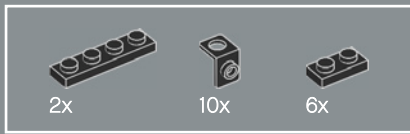

90

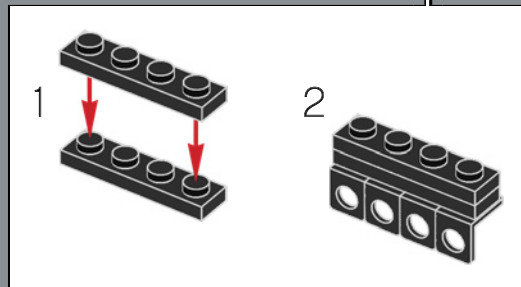
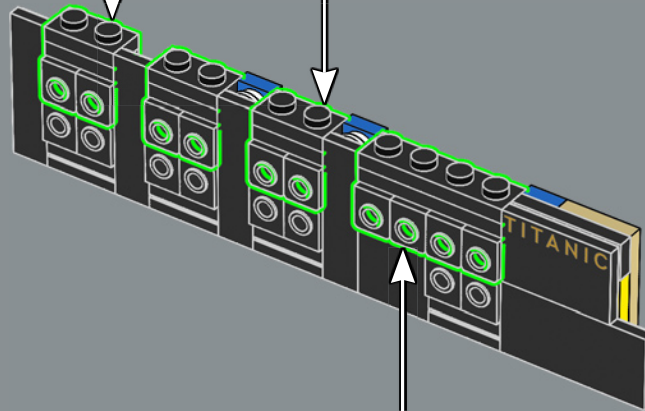
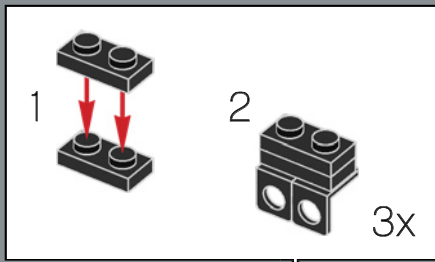

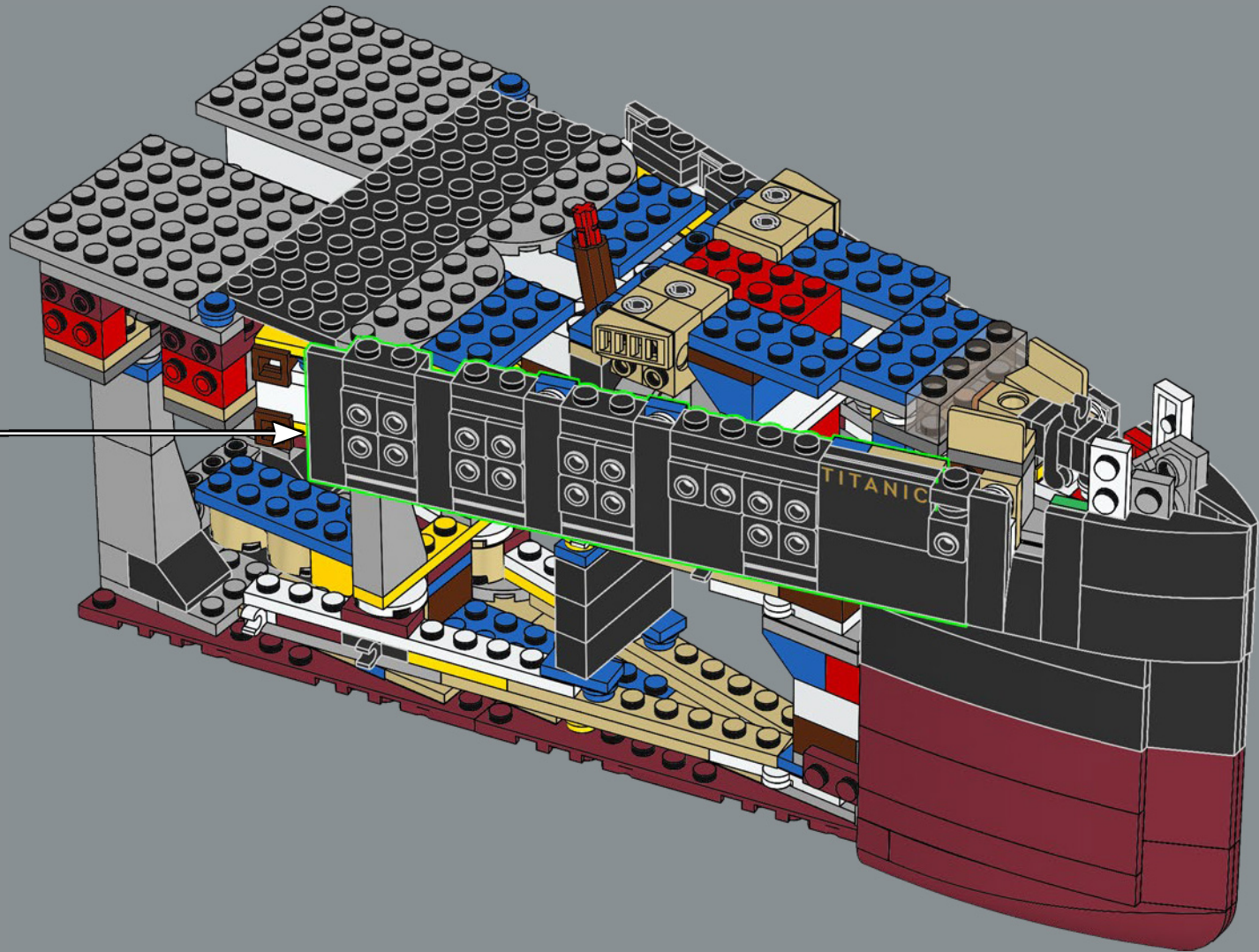



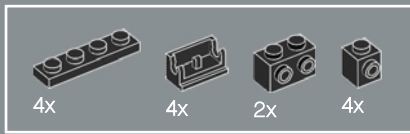

92

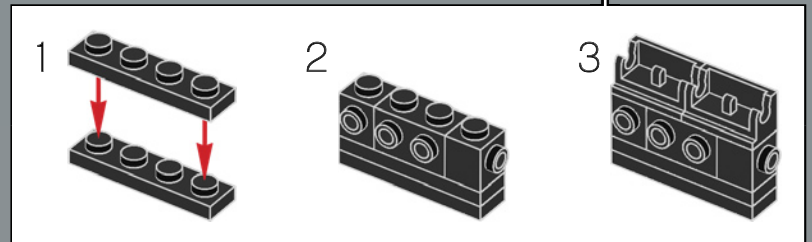
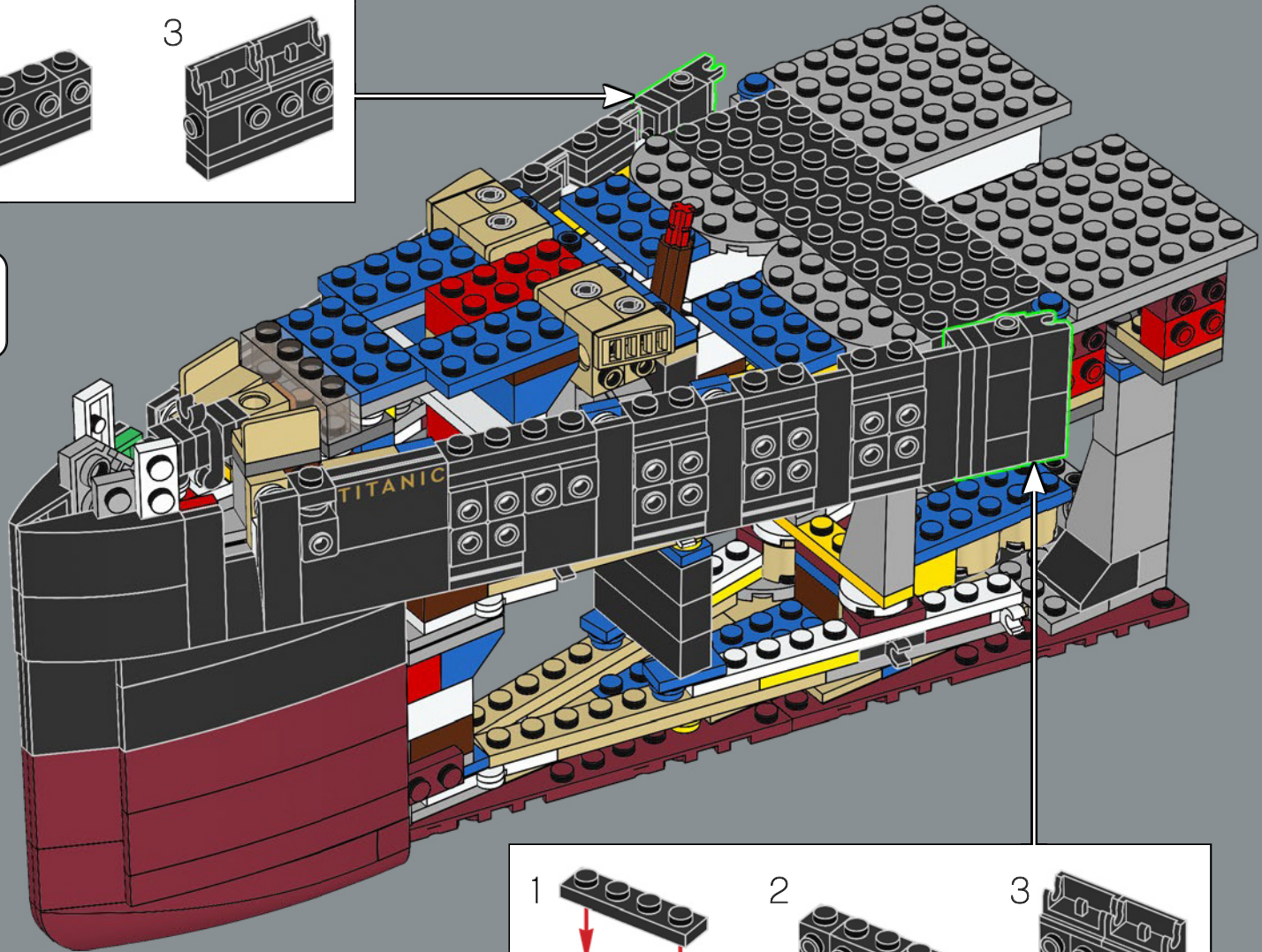
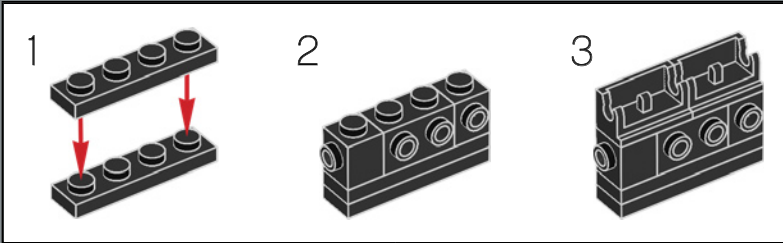

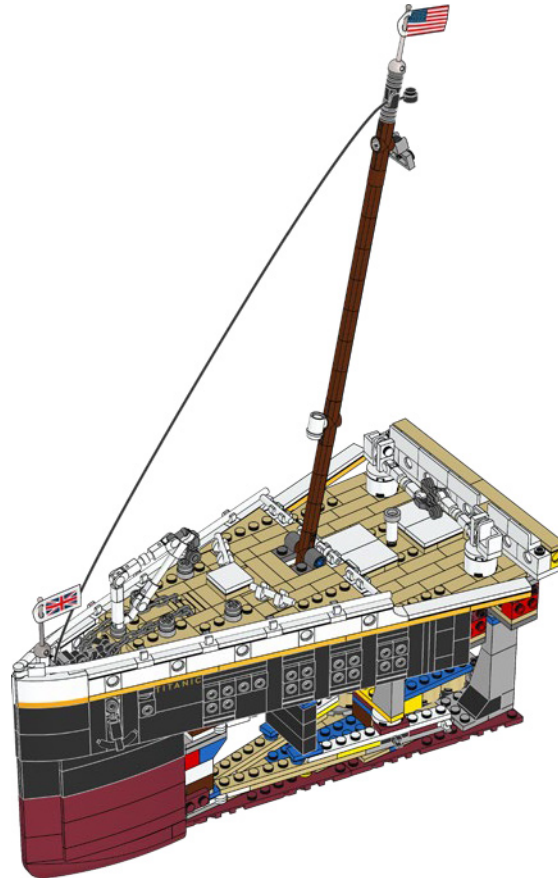

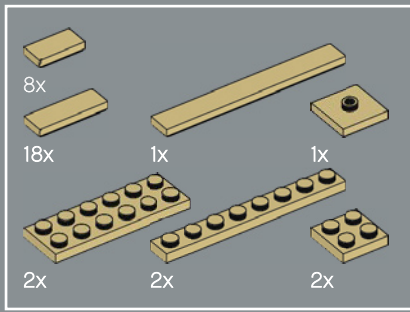

93

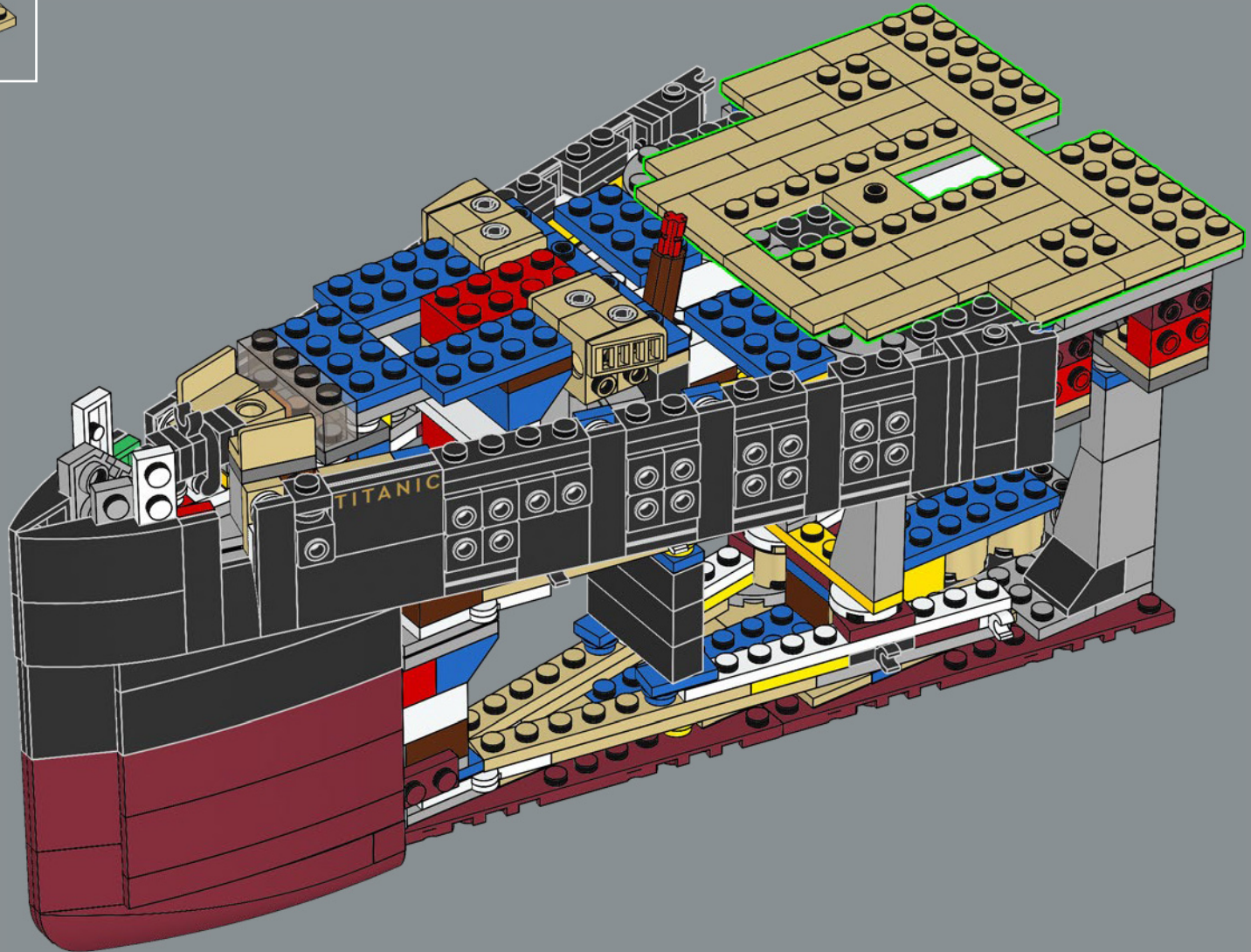

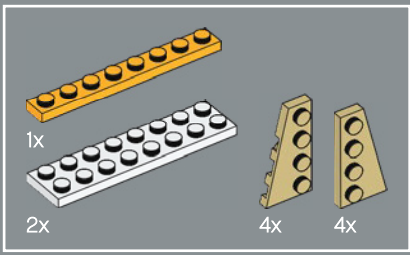

94

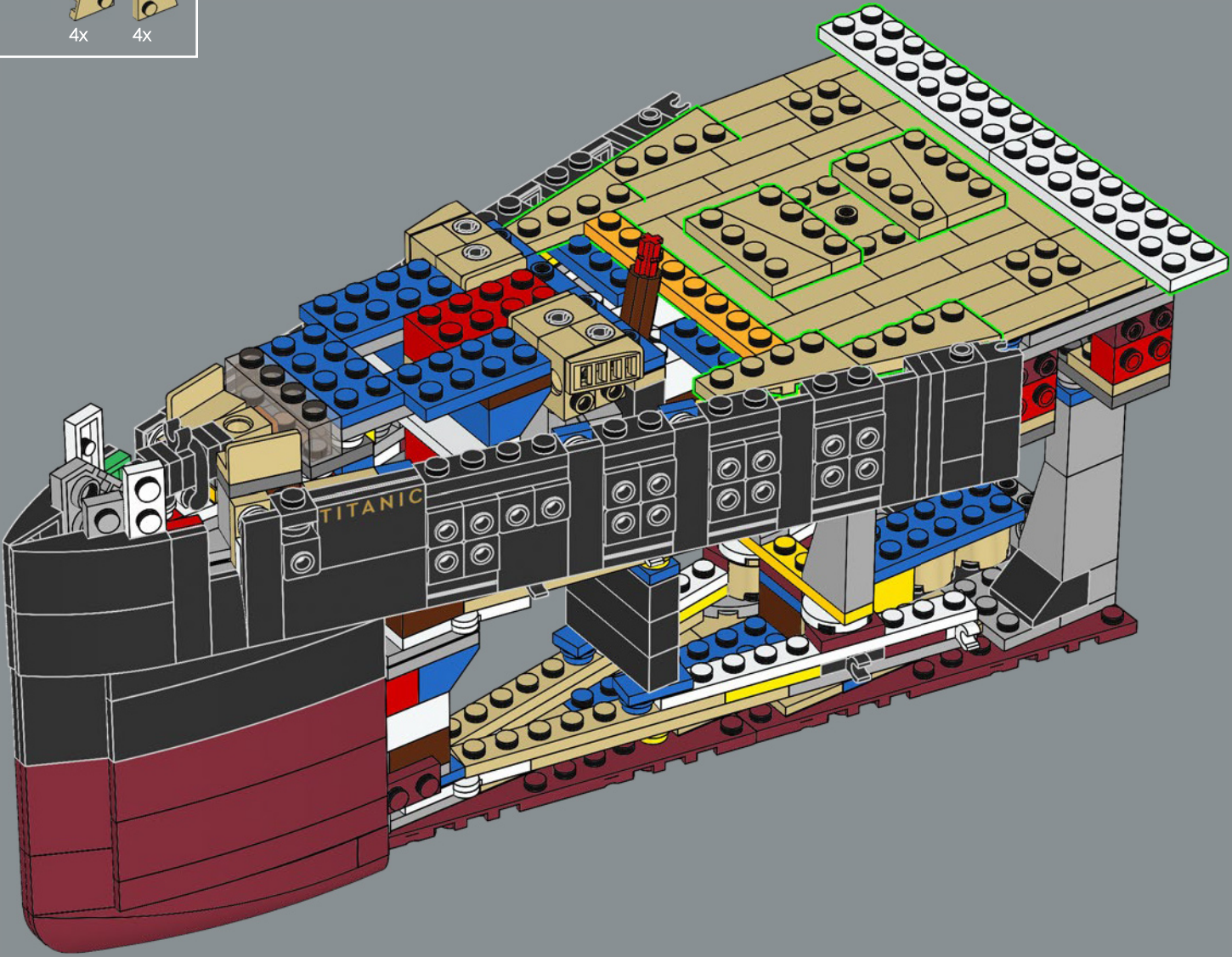

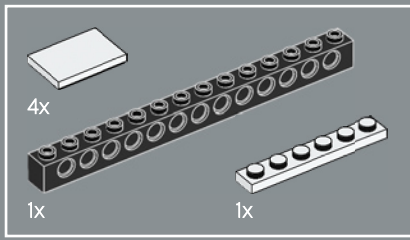

95

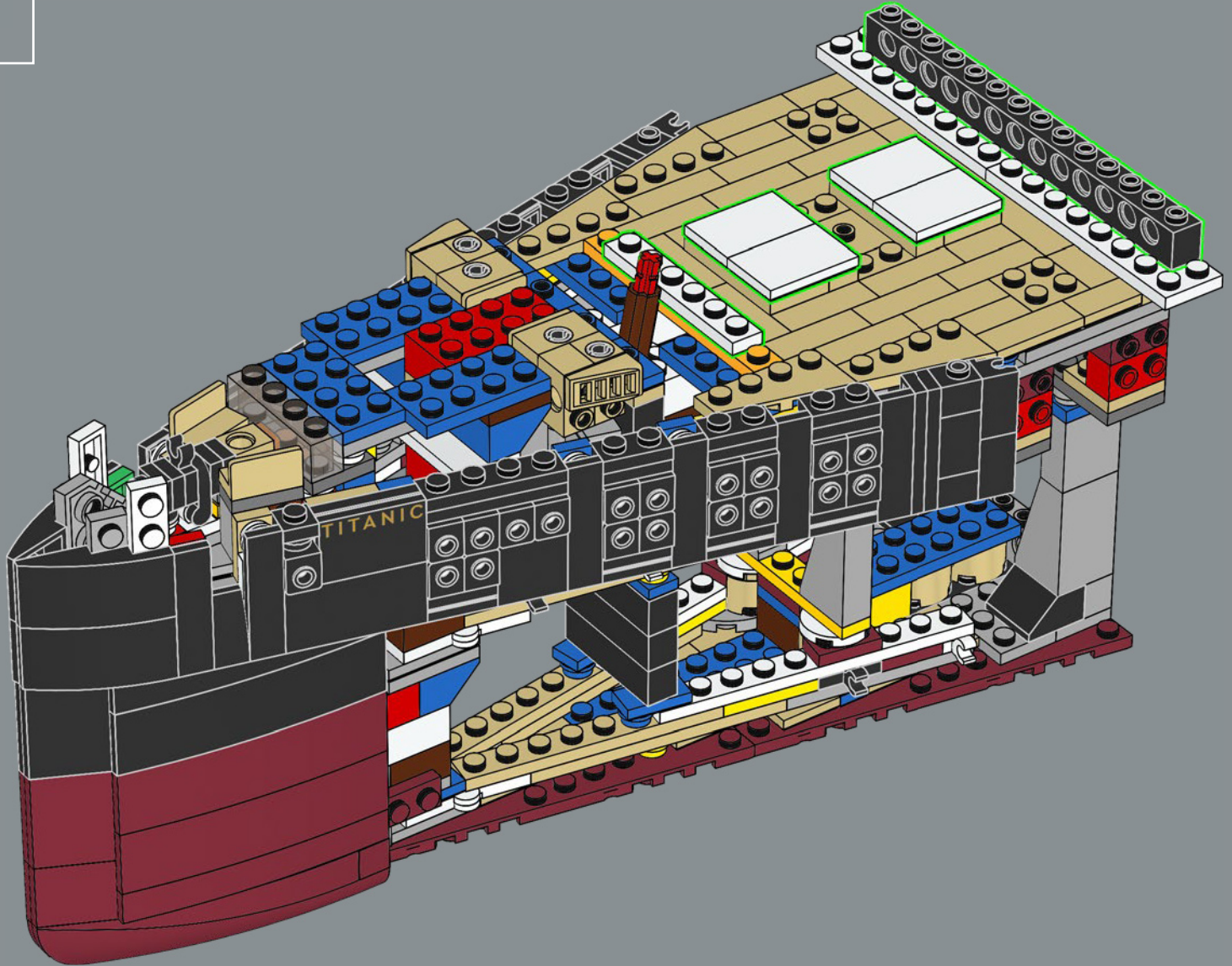

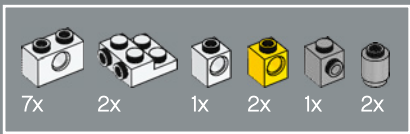

96

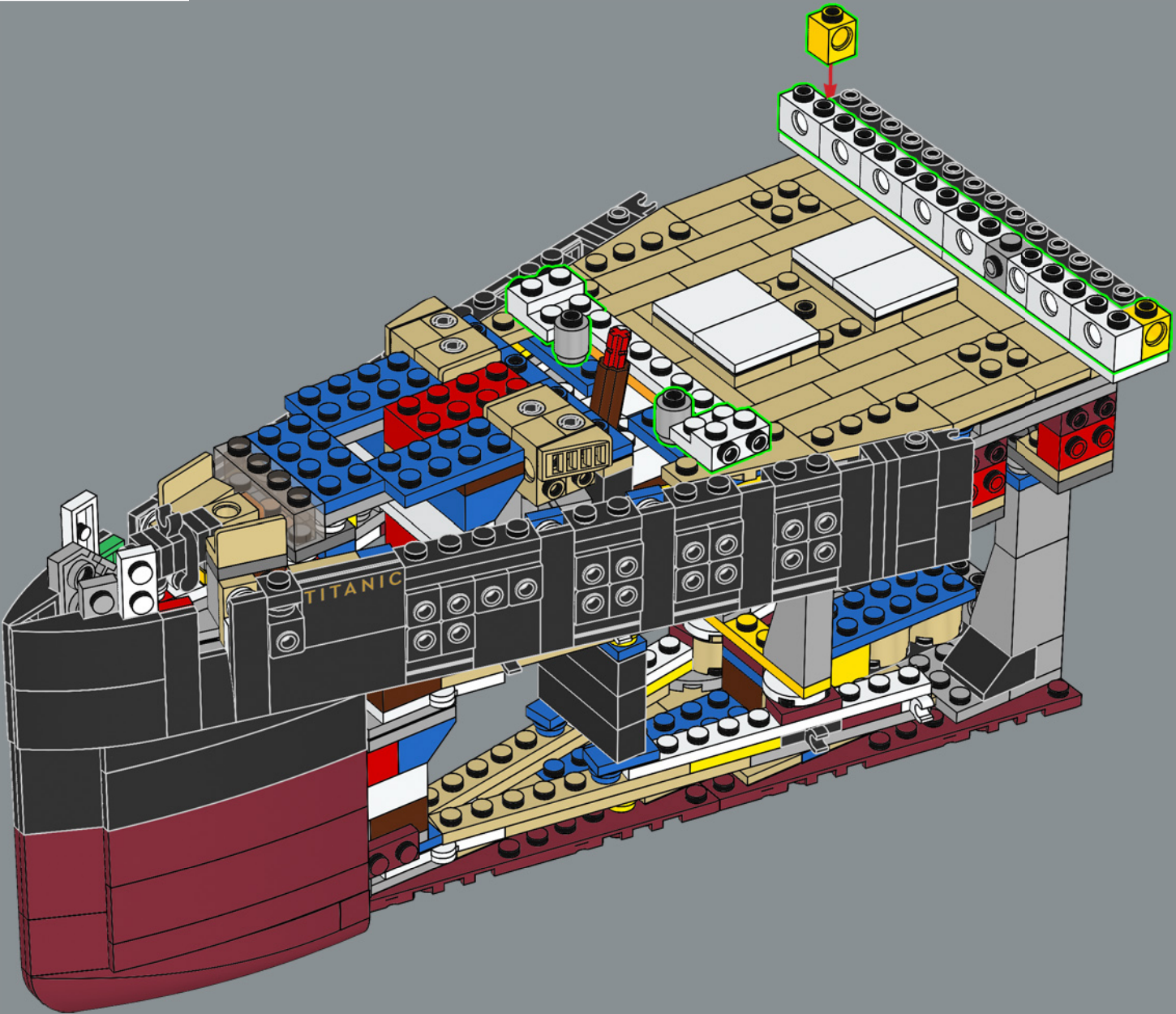

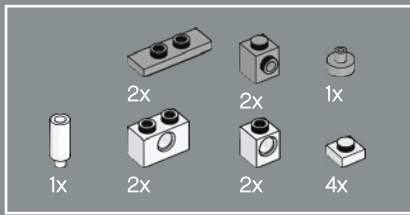

97

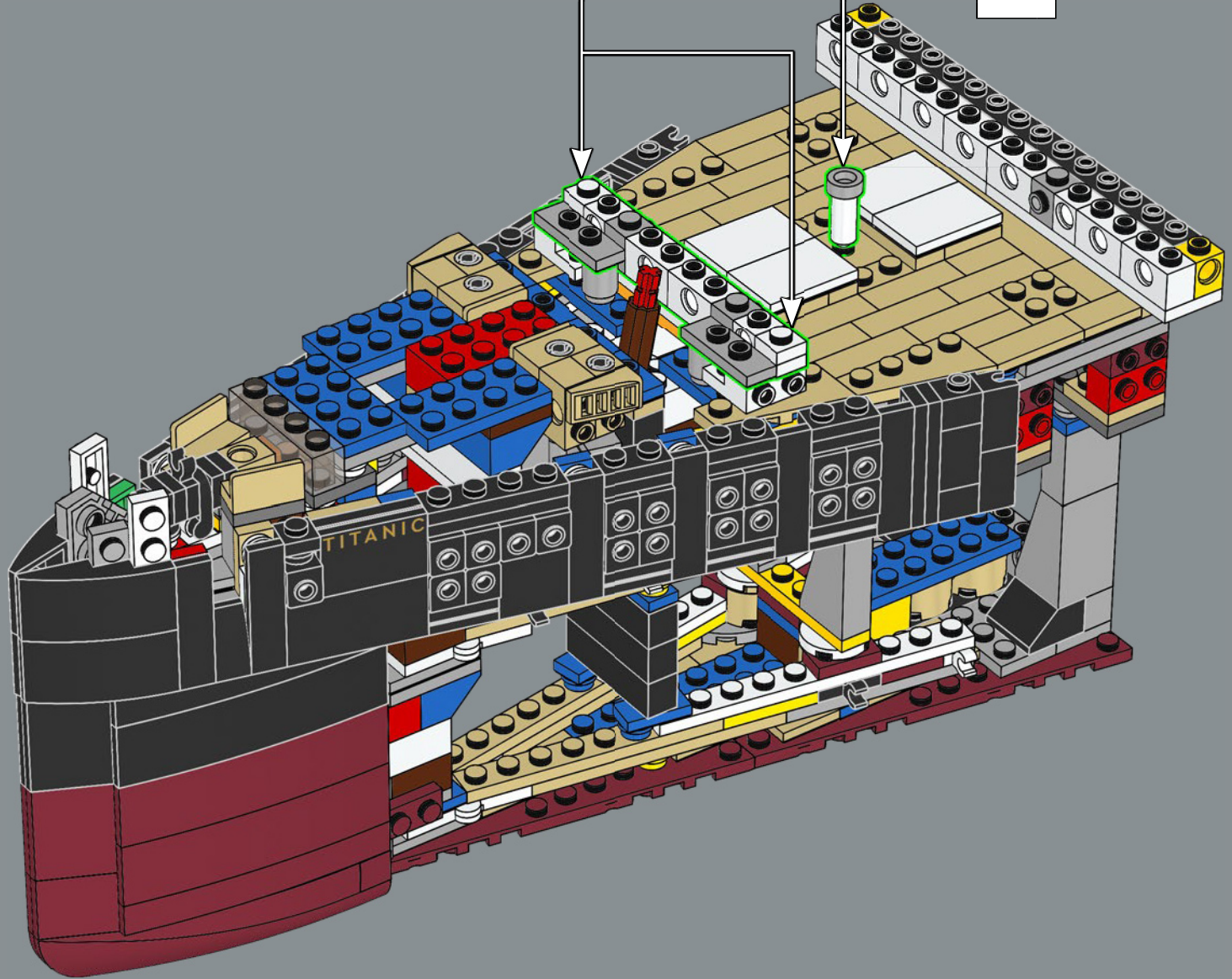
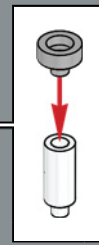
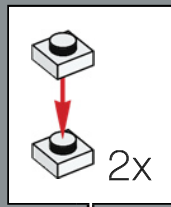

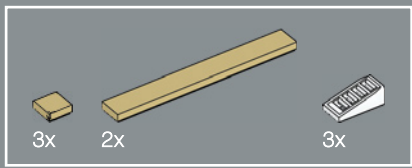

98

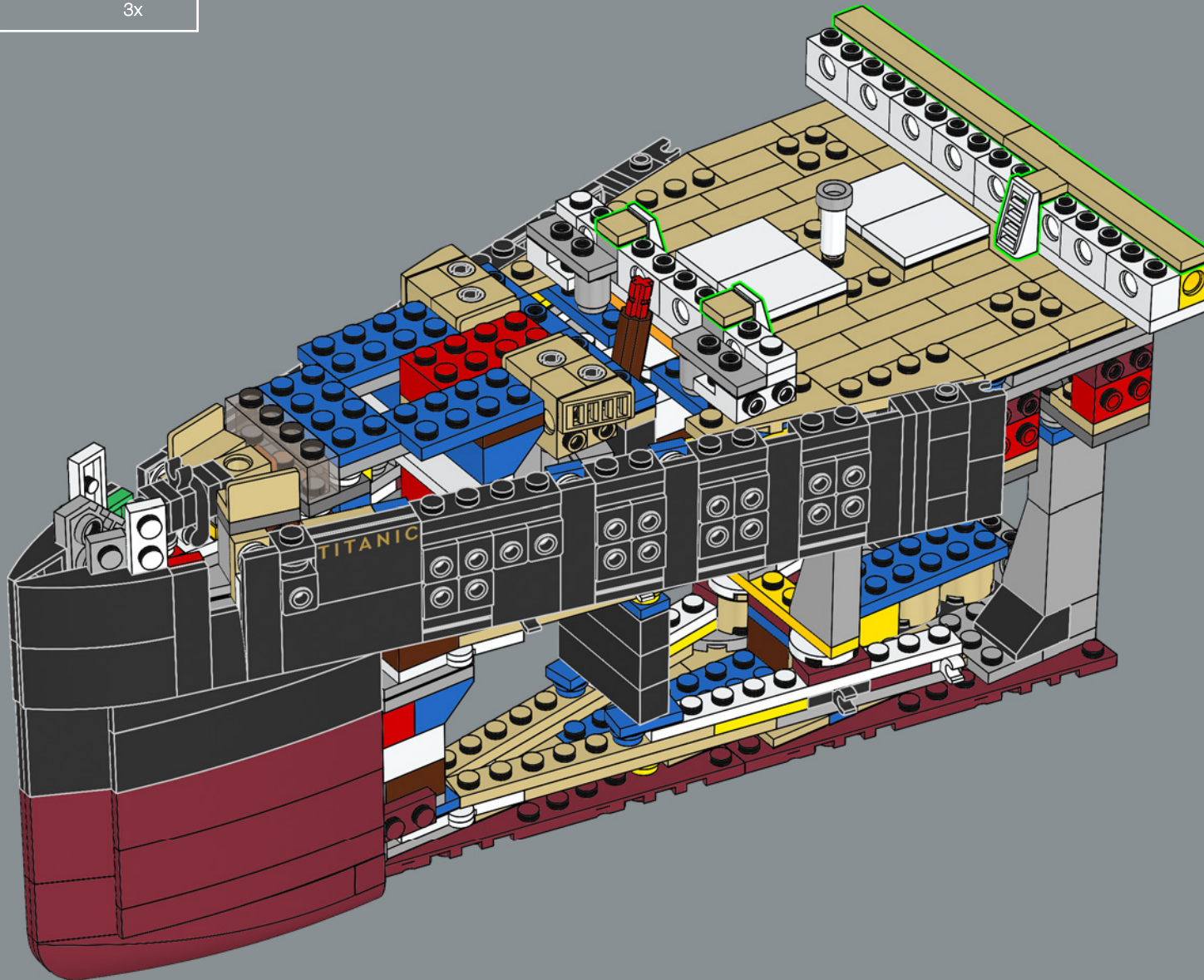



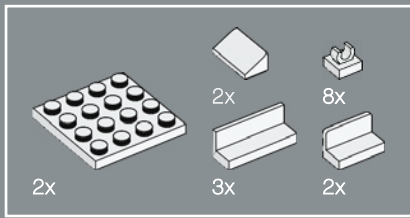

99

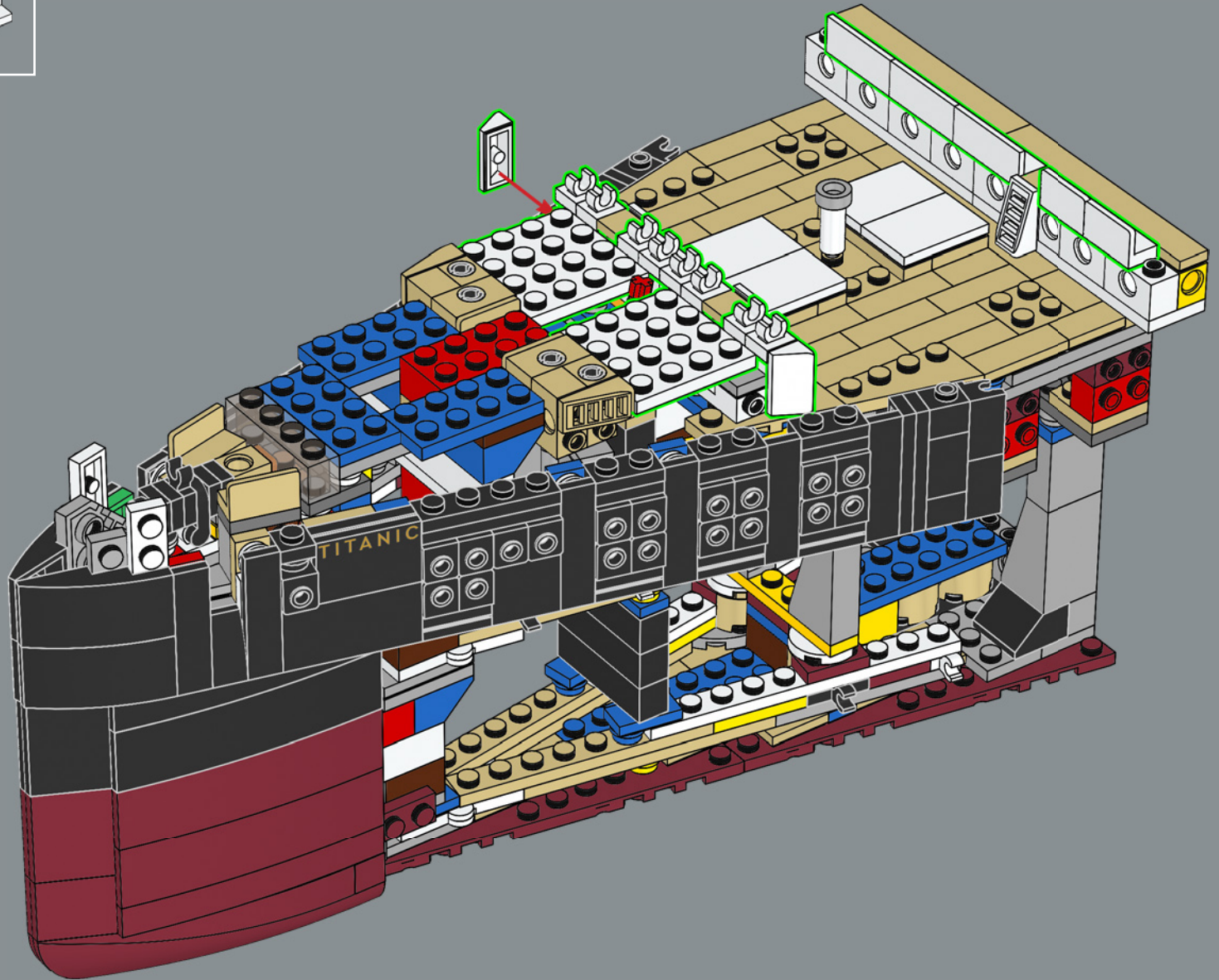

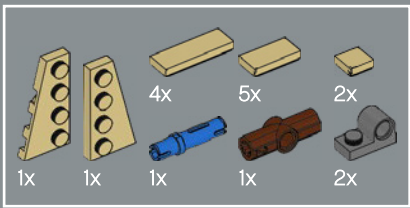

100

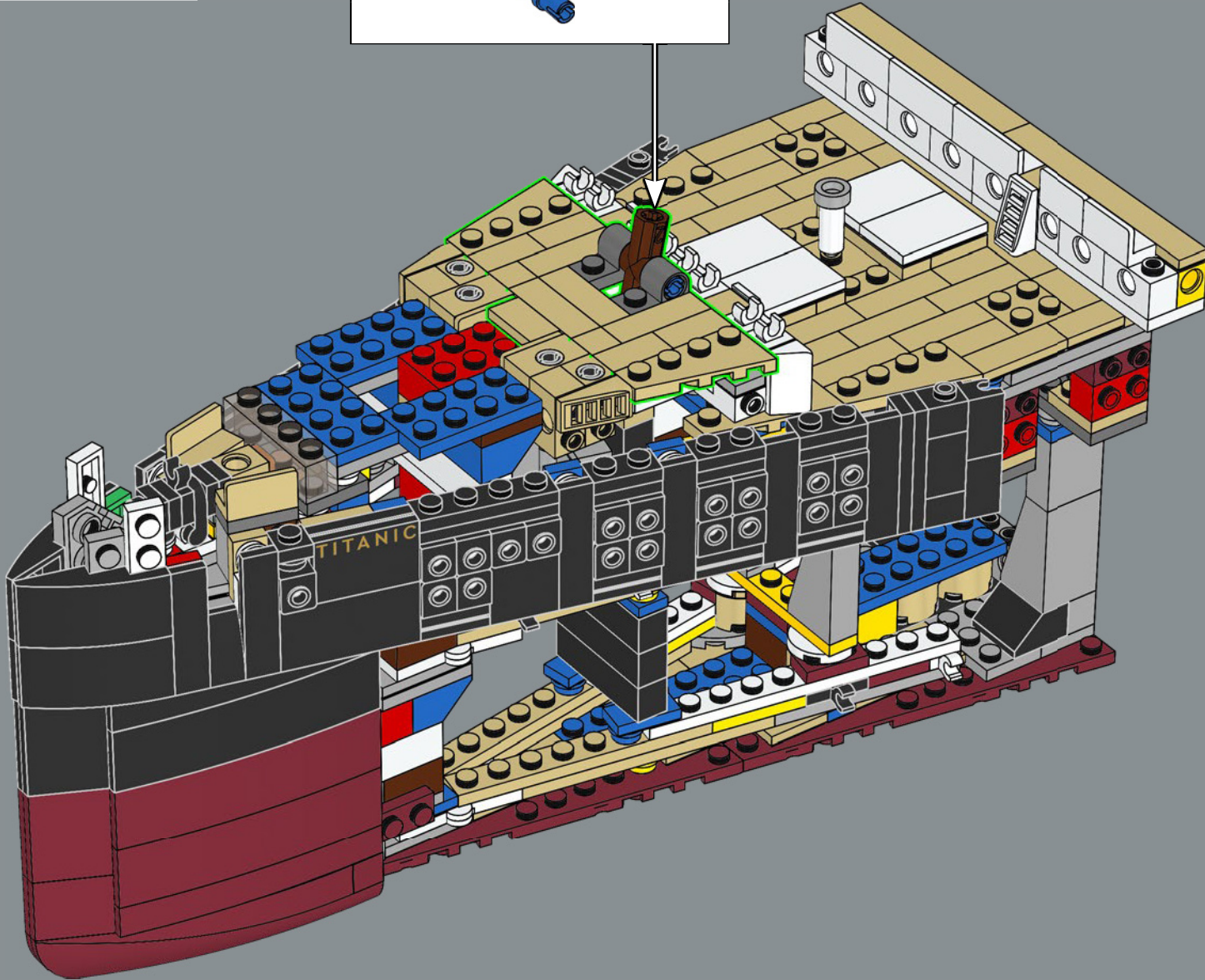
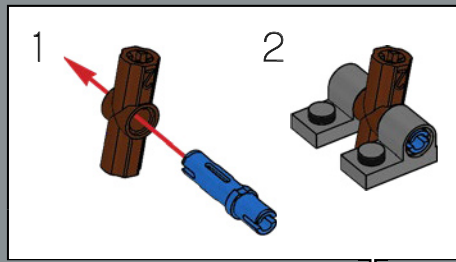

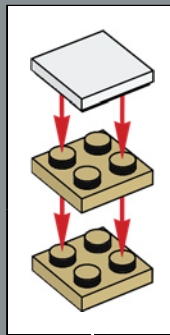
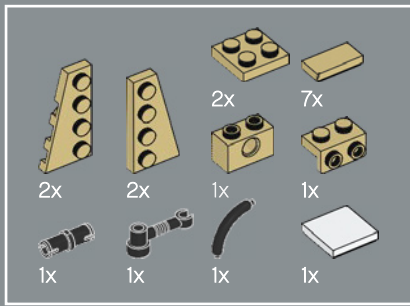

101

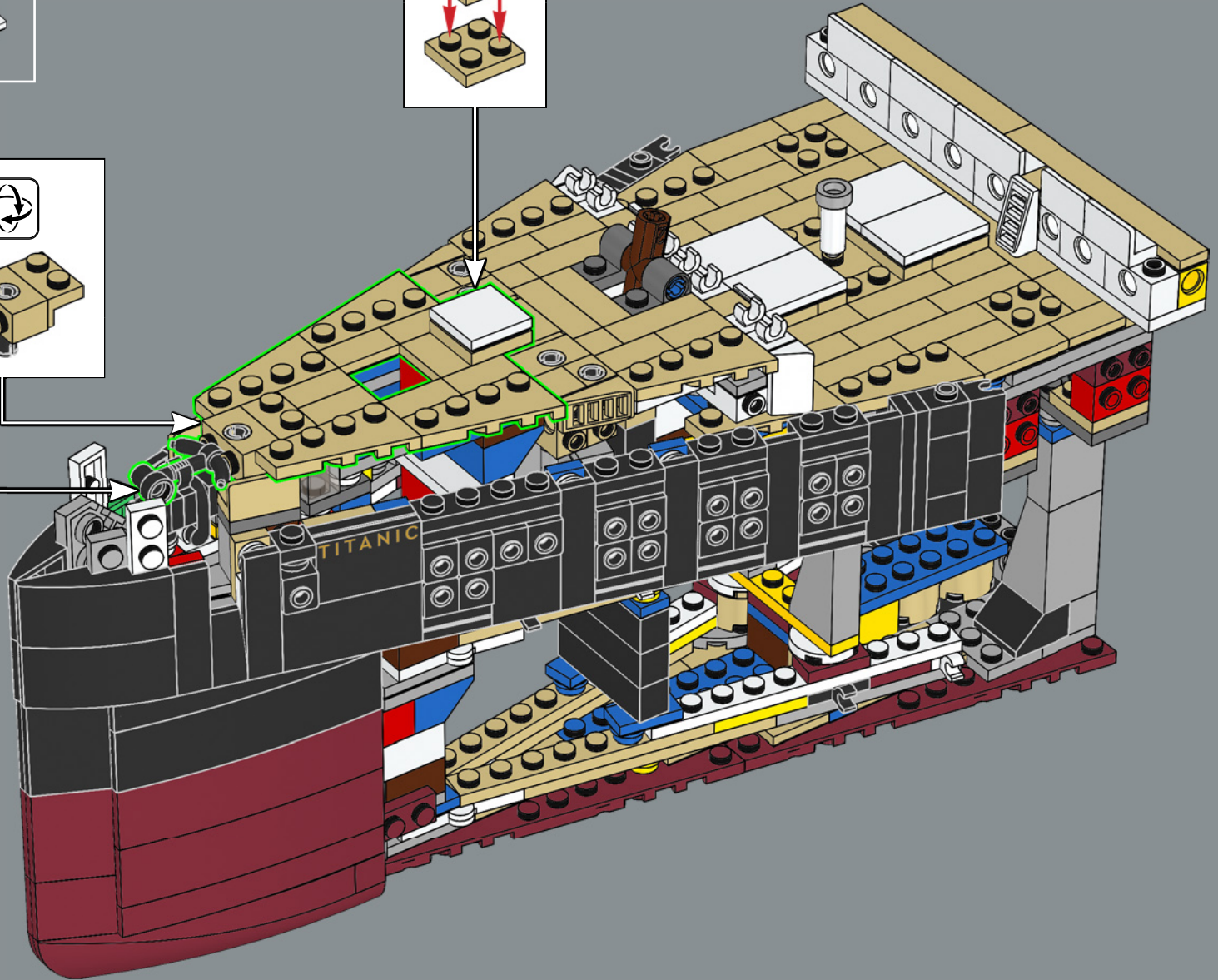
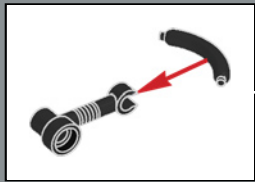
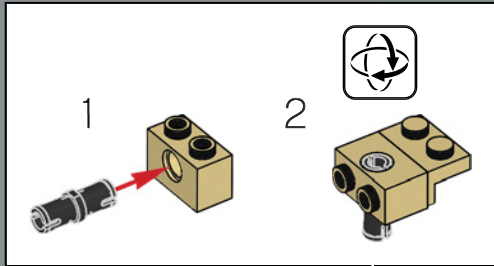

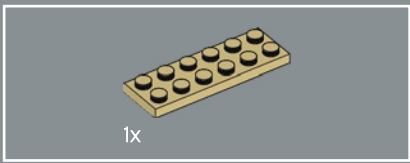

102

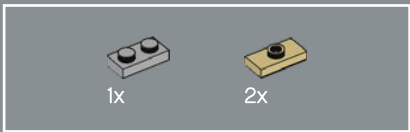
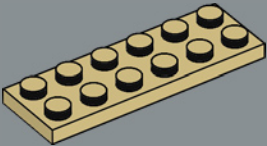

103

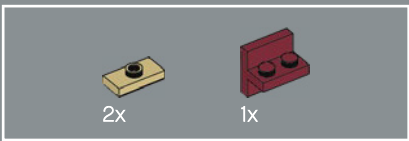
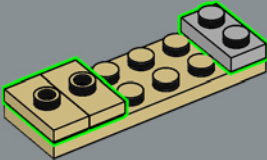

104

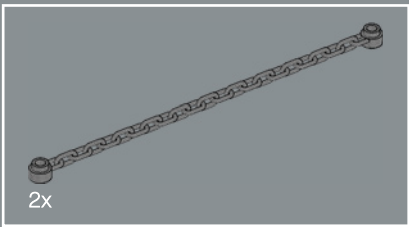
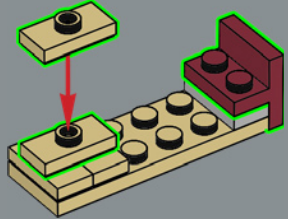

105

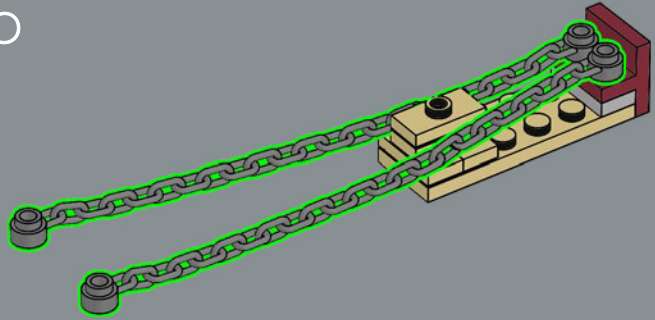

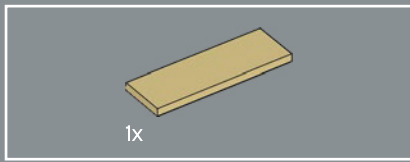

106

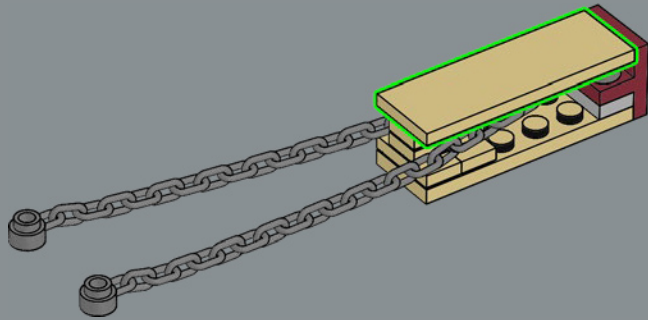

107

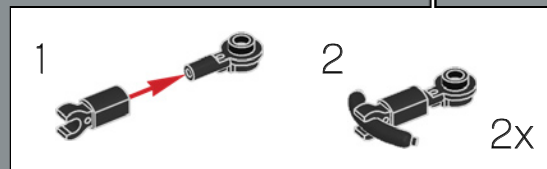
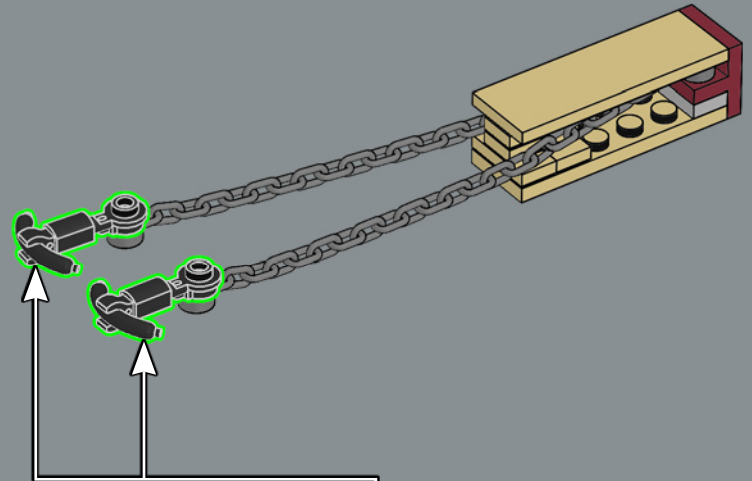

Le Titanic possède trois ancrés :  
une de chaque côté et la plus lourde au centre.

108

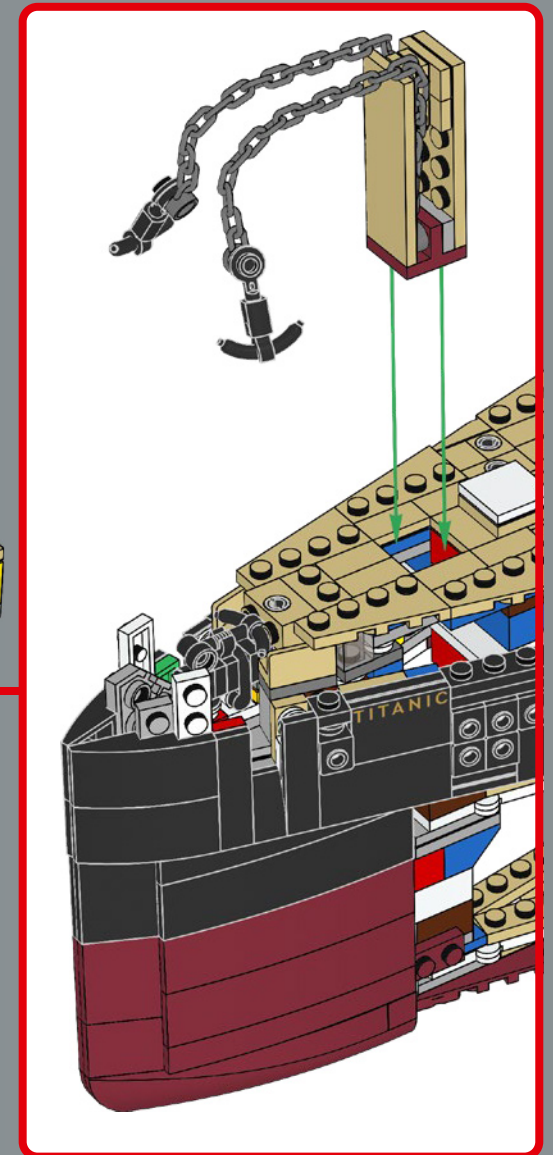
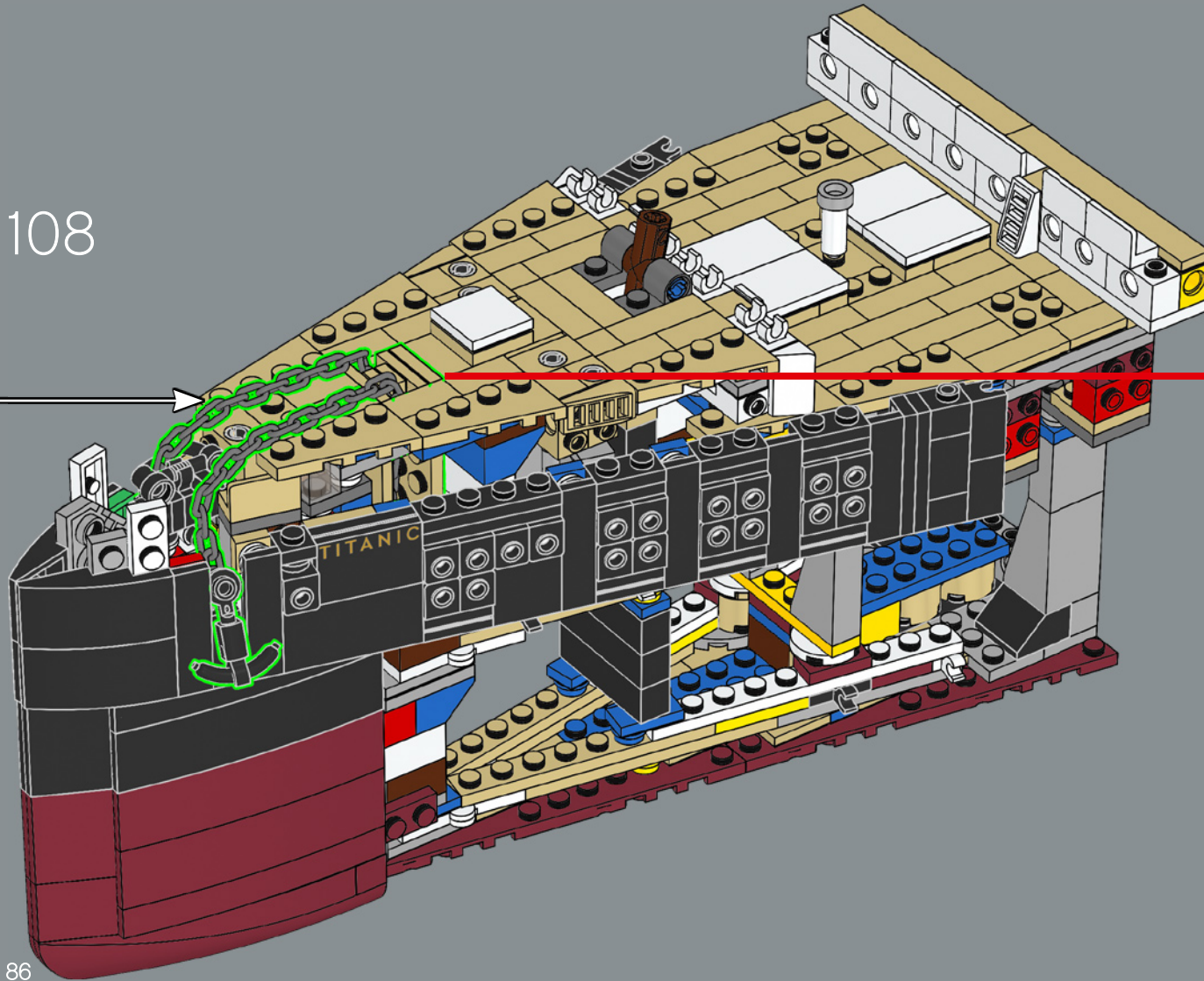

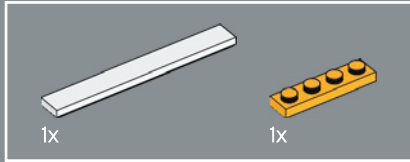
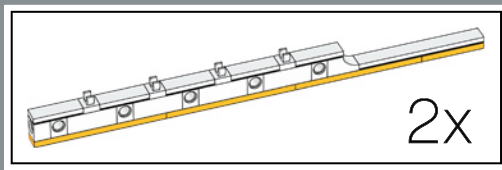

109

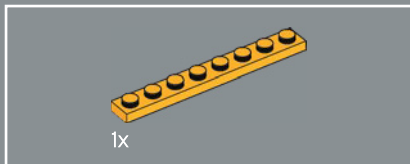
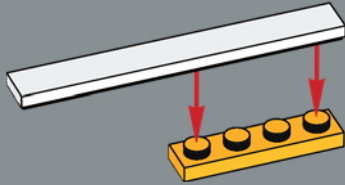

110

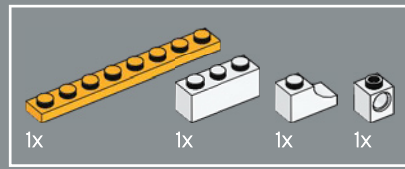
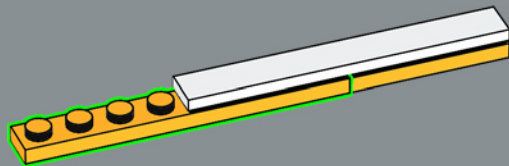

111

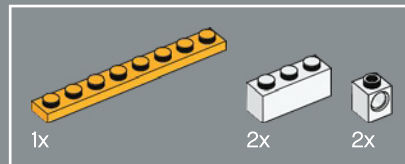
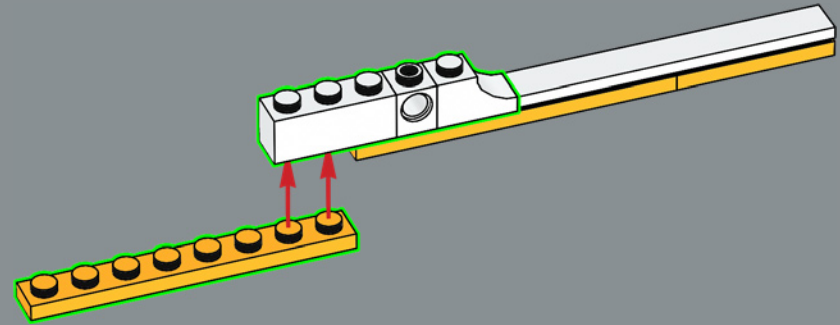

112

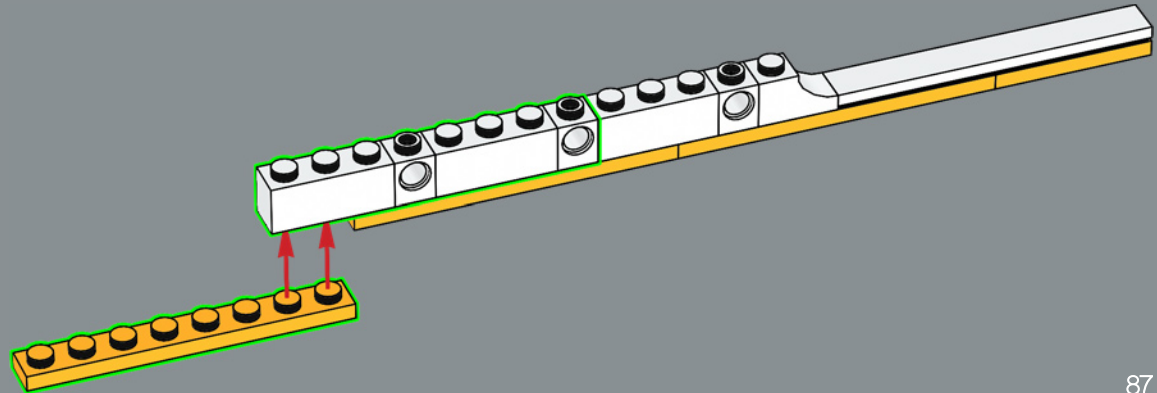

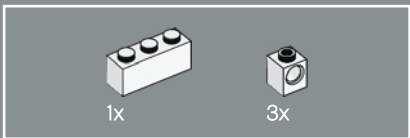

113

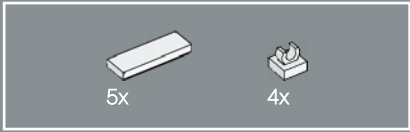
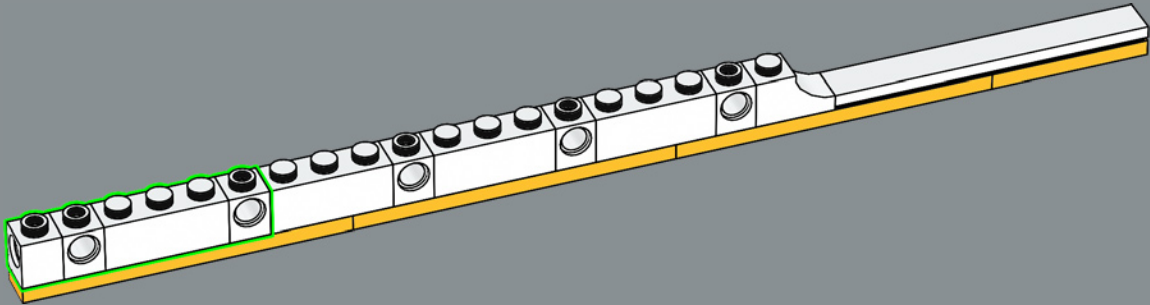

114

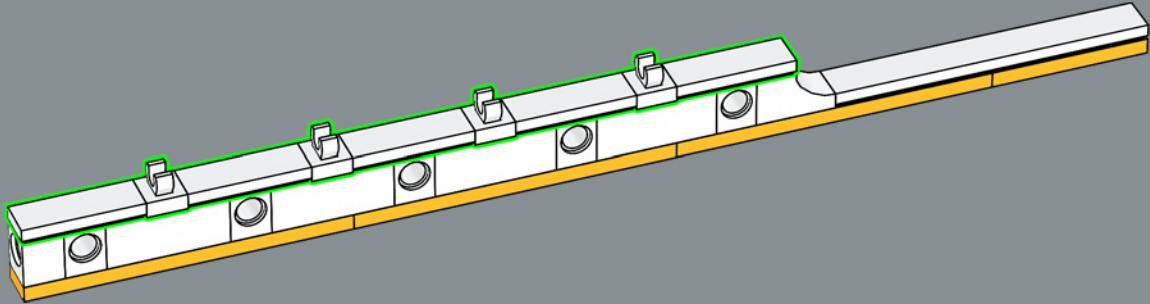

2x



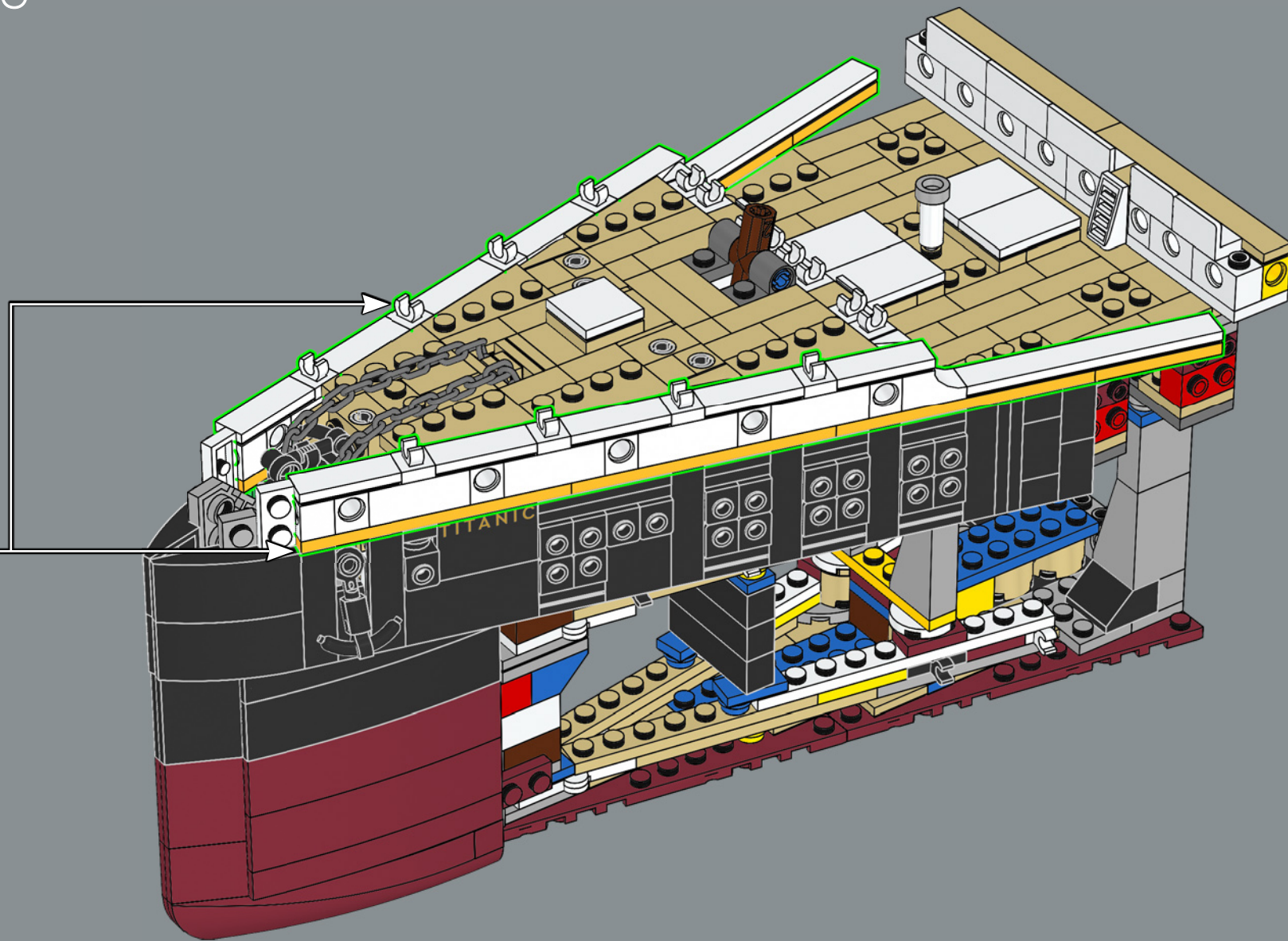

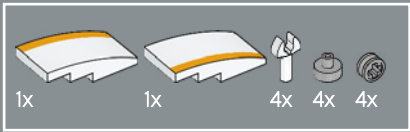

116

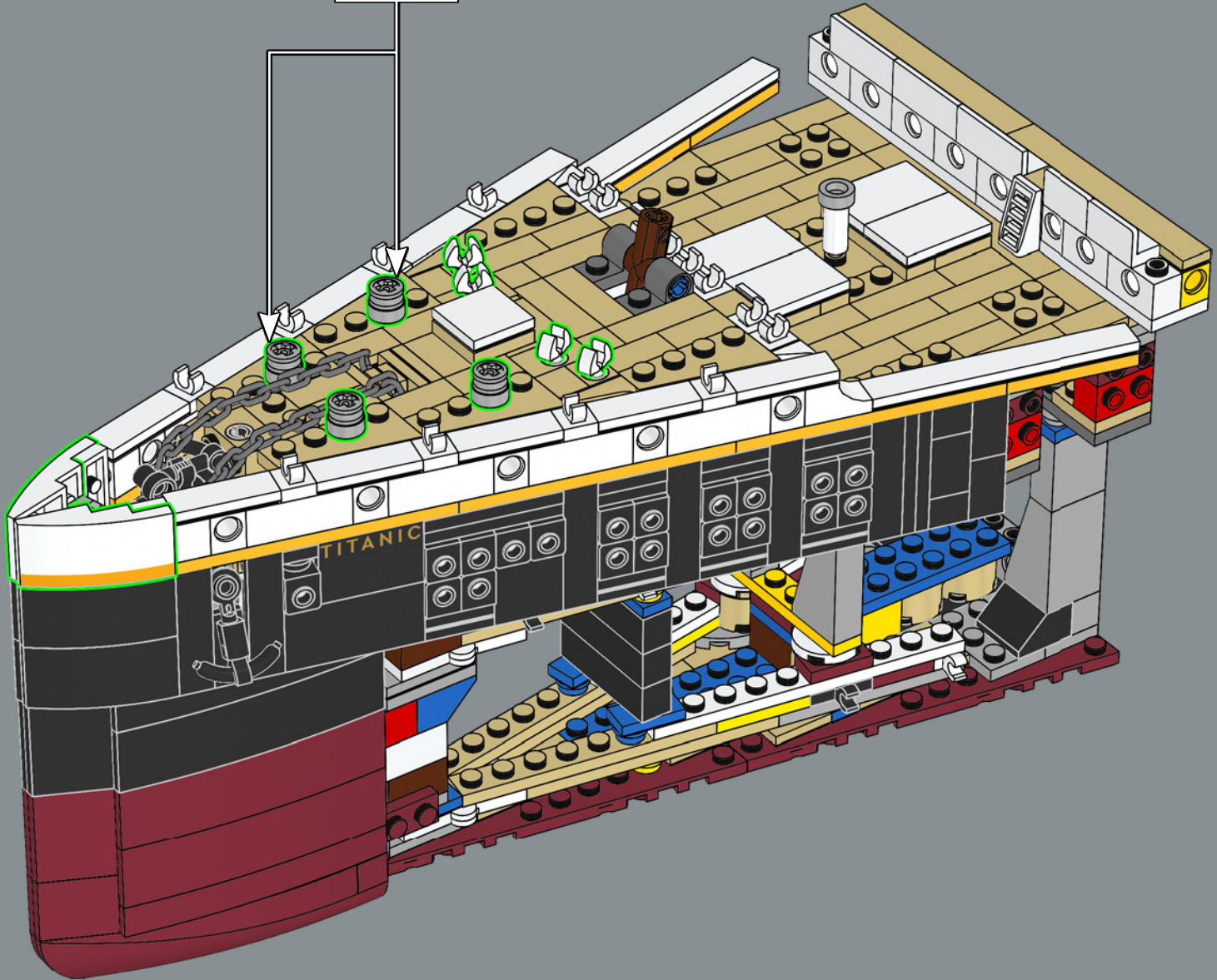
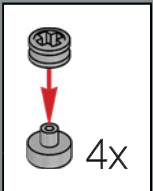

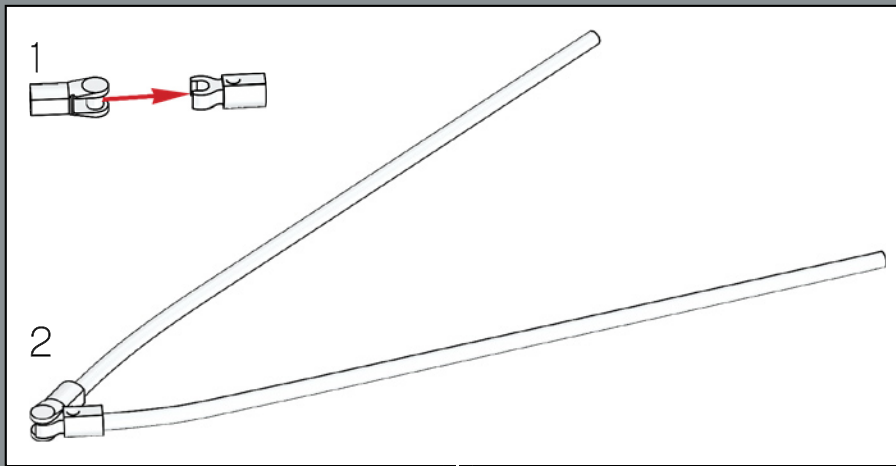
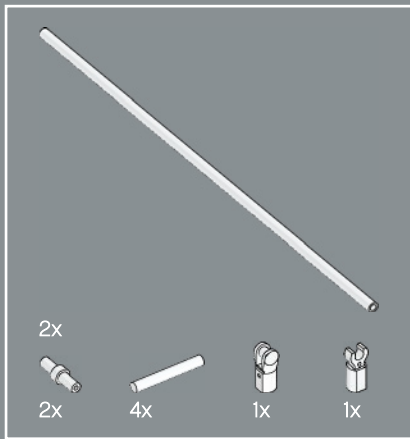

117

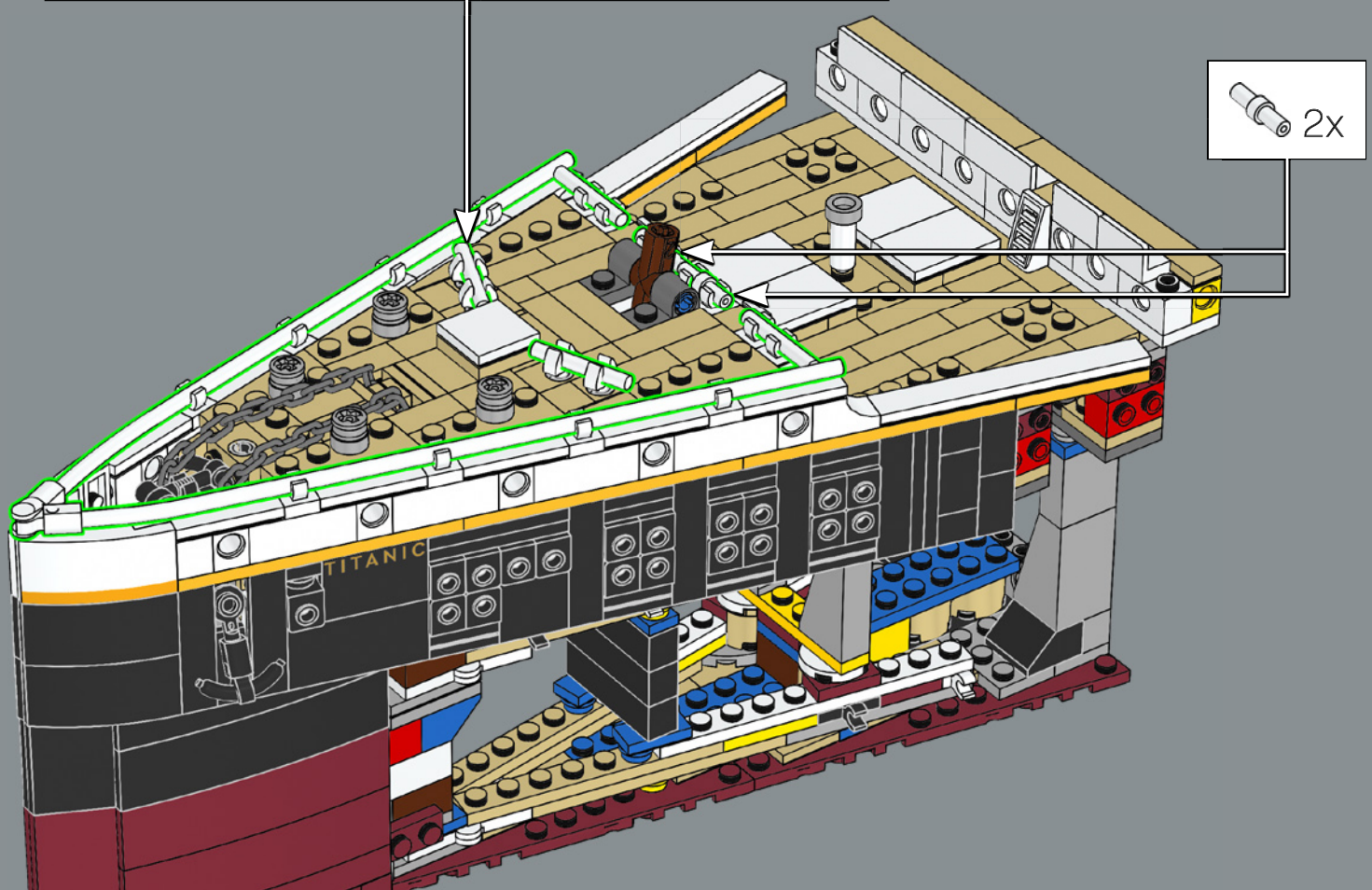
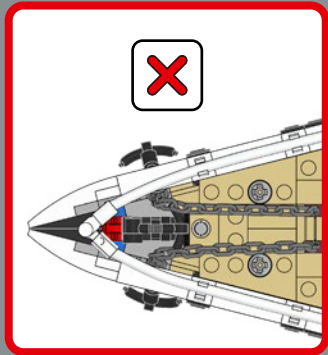
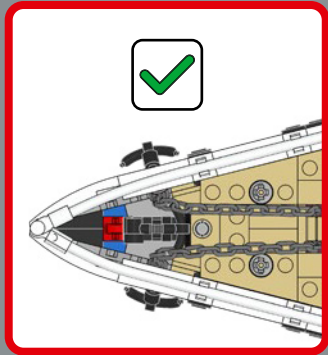



118

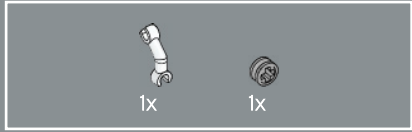

119



120

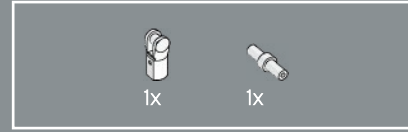
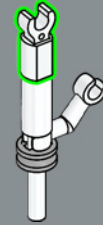

121

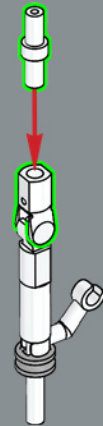



122

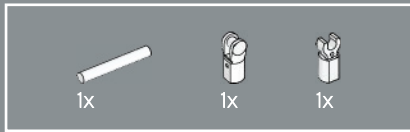
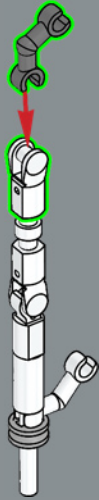

123

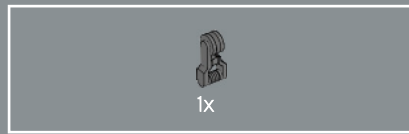
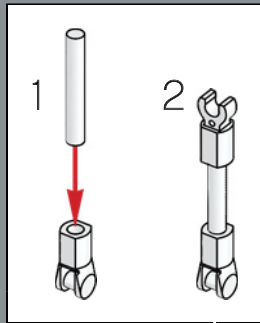
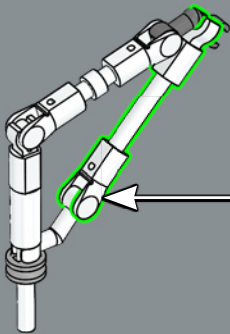

124

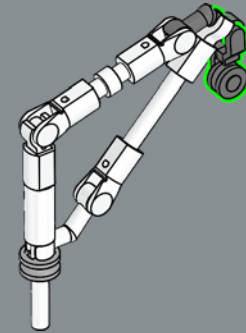

125

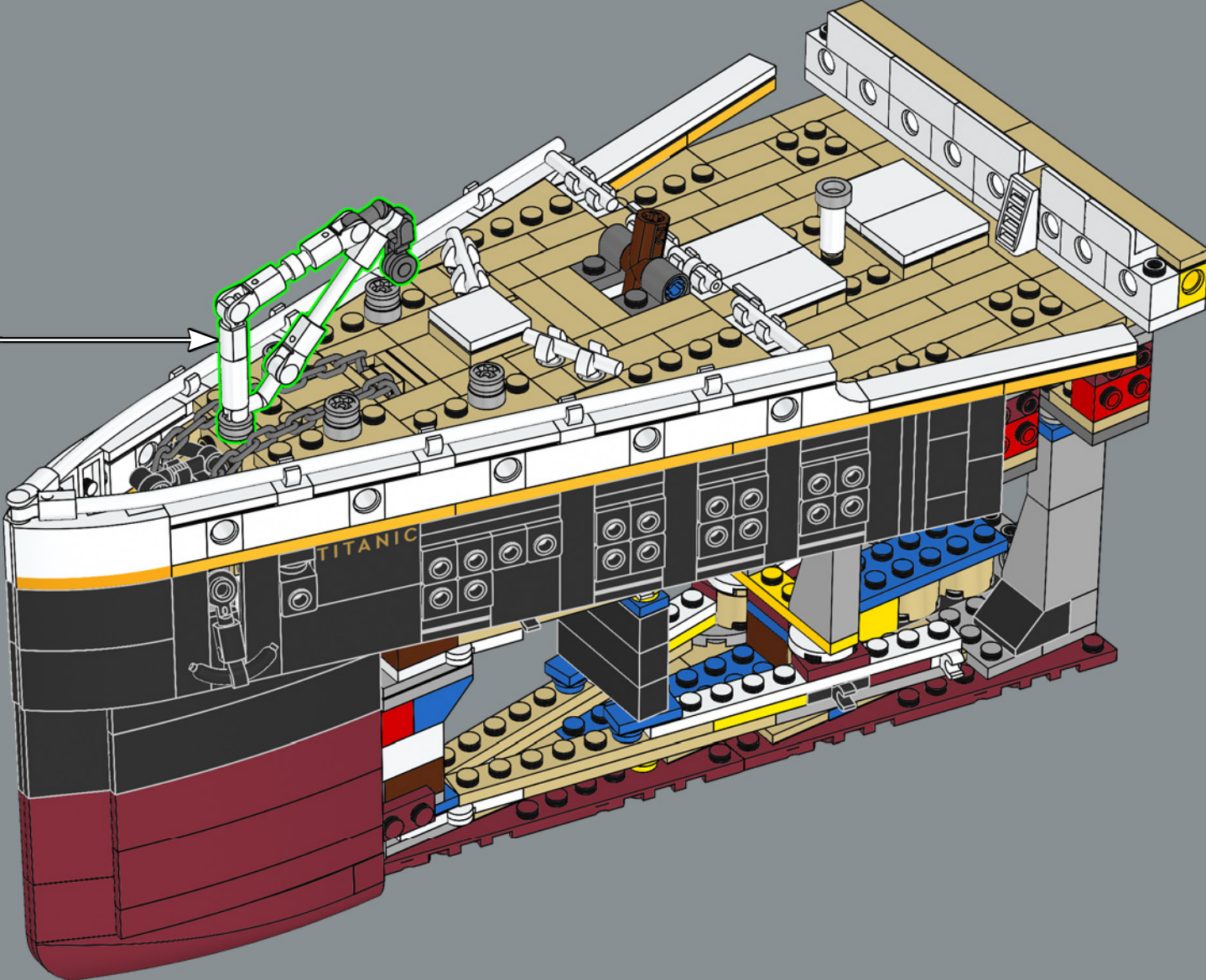

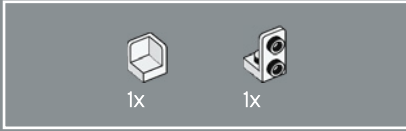
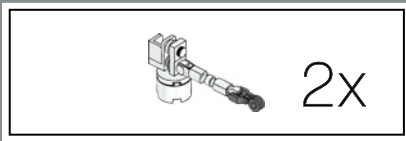

126

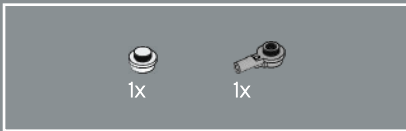

127

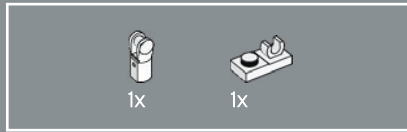
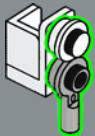

128

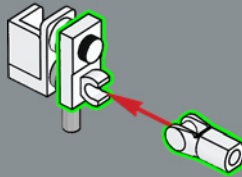

129

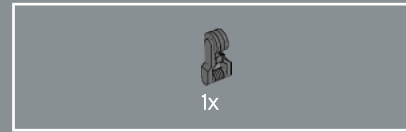
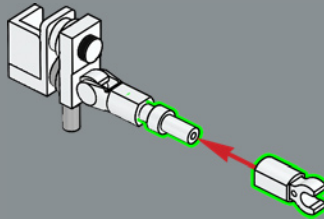

130

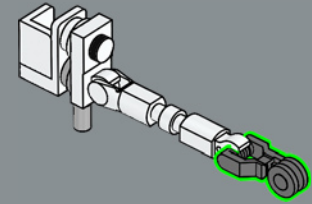

131

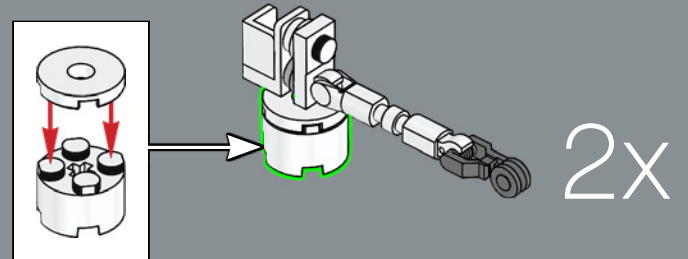

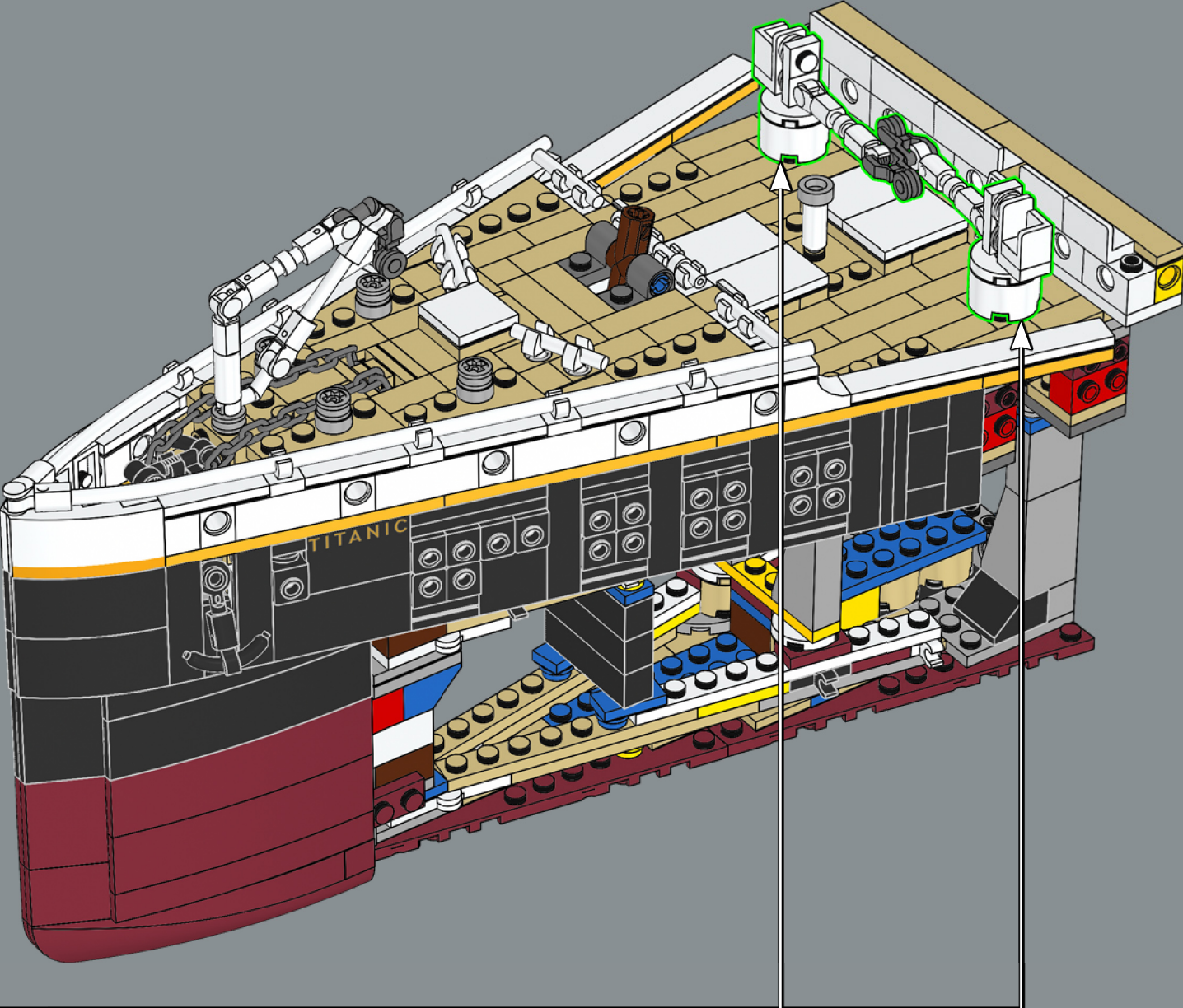



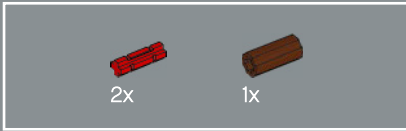
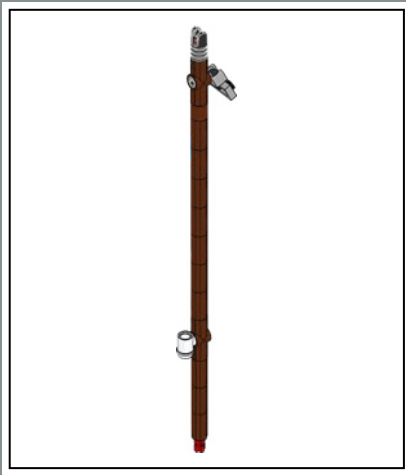

133

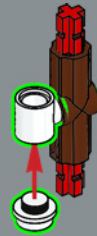
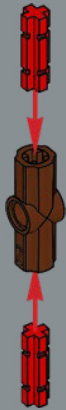

134



135

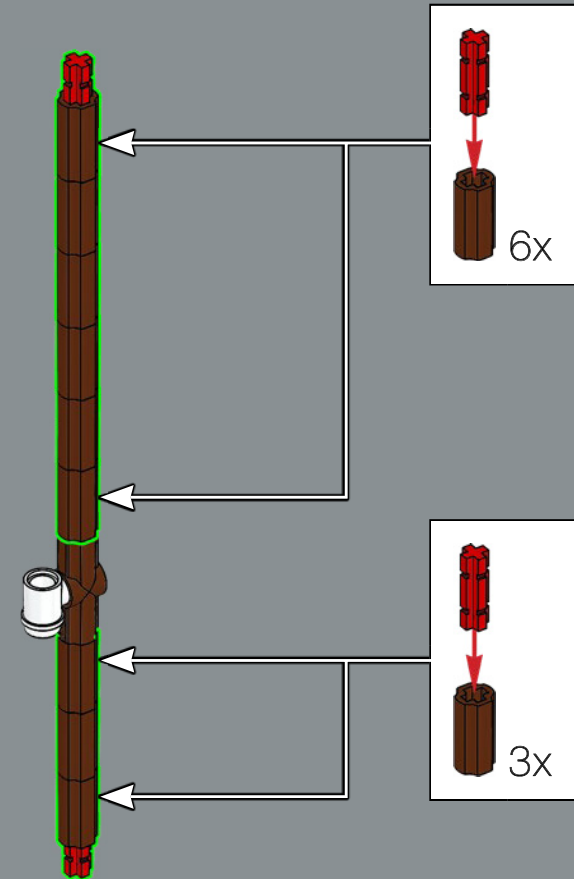

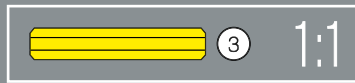
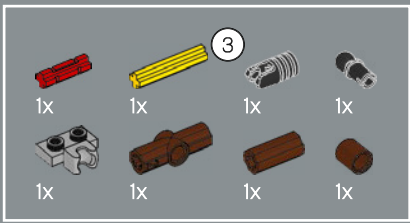

136

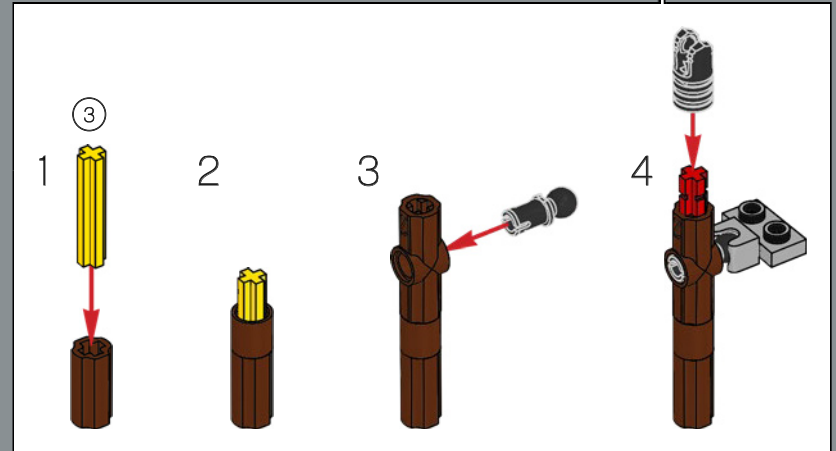

137

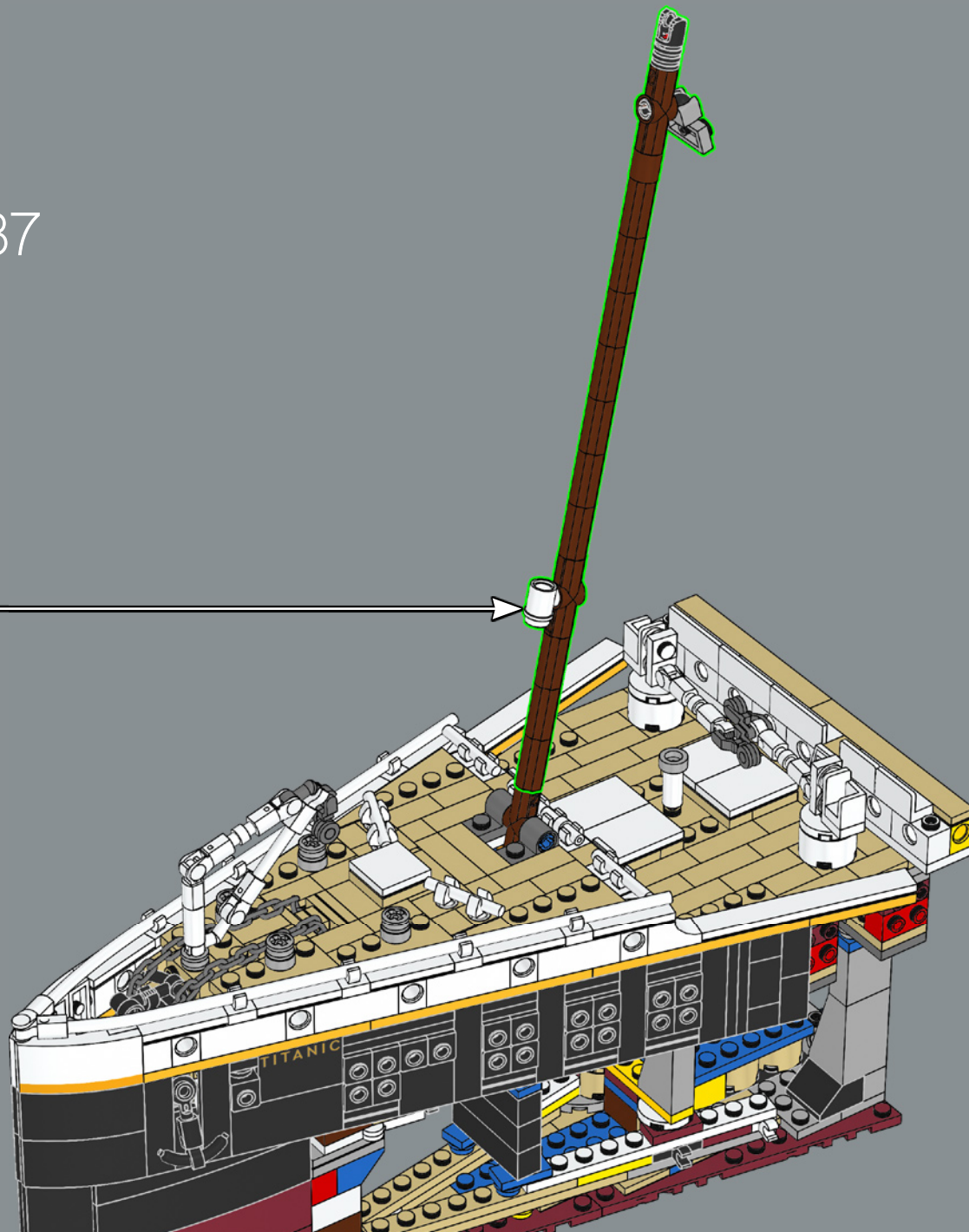

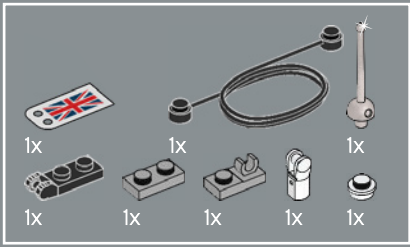

138

1

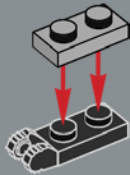

2

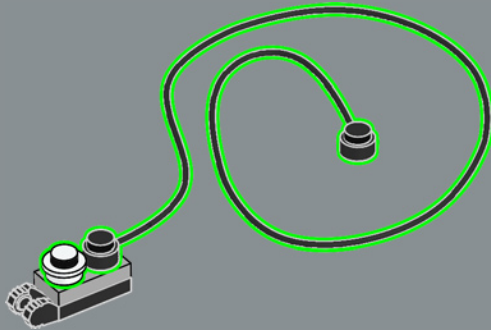

3

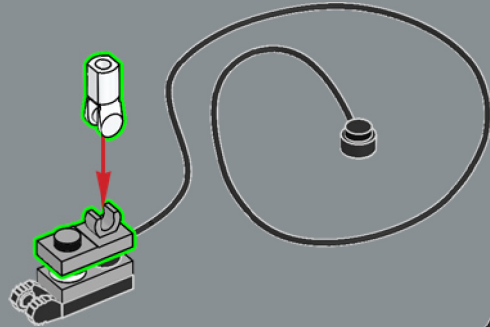

4

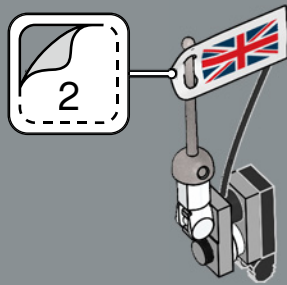

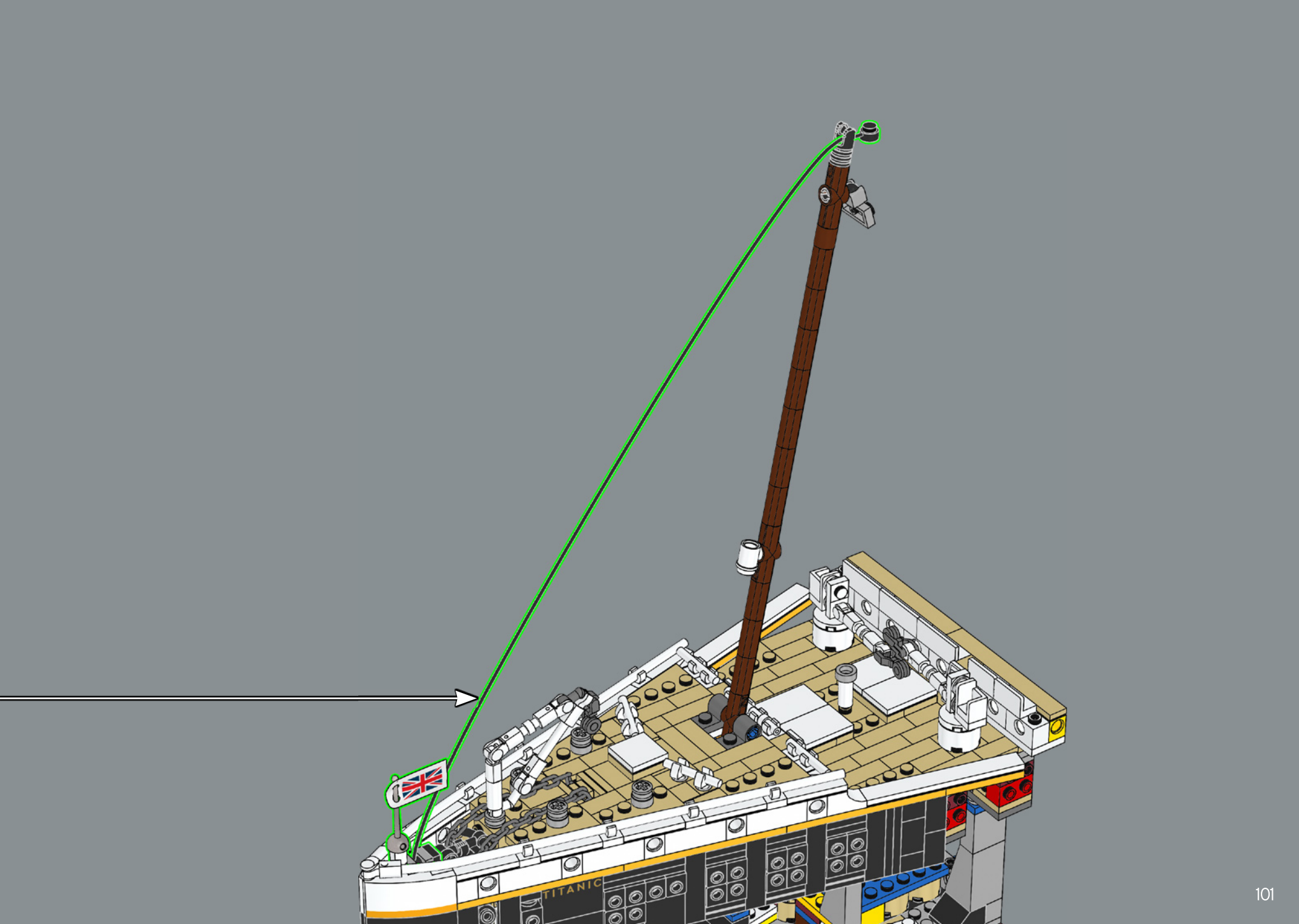

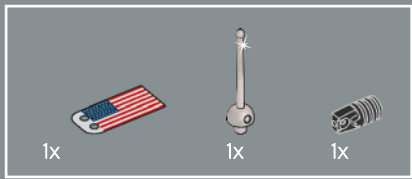

139

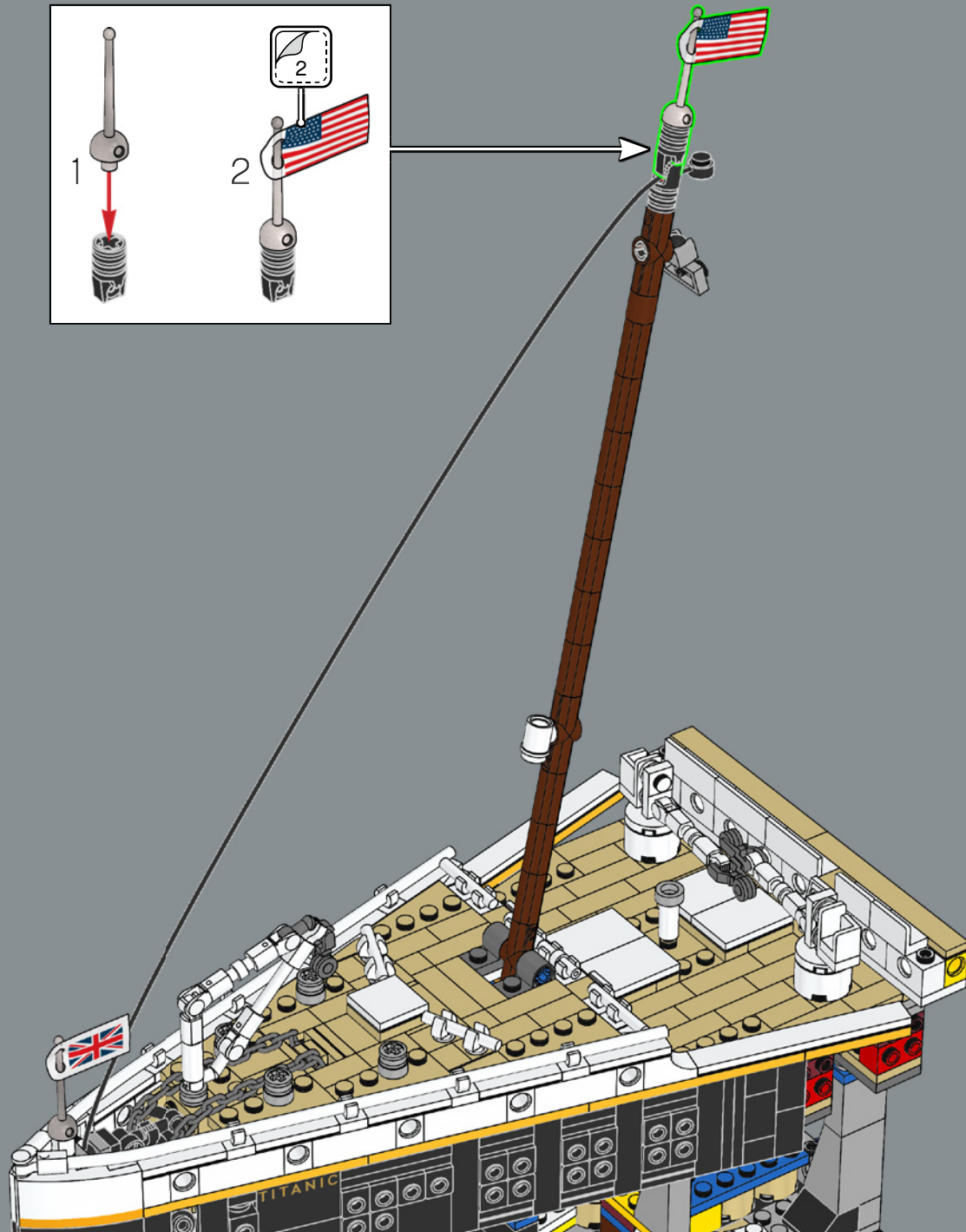
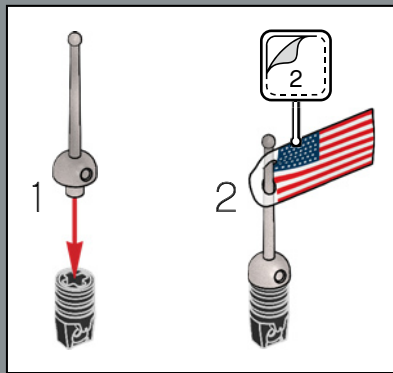

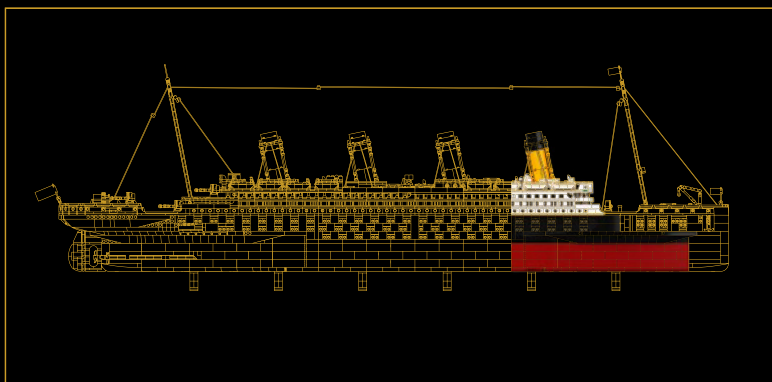

## SECTION 2:

# PONT ET CHEMINÉE

Dans cette deuxième section, la coque atteint sa largeur maximale, soit 18 modules ou environ 144 mm. À l'intérieur de la coque, vous commencerez à construire la section transversale du navire, dont une partie de la piscine, le grand escalier et l'une des chaufferies du *Titanic*. Vous construirez également le château emblématique et la première des quatre cheminées.

↓ Un mécanisme de verrouillage caché à l'intérieur du grand escalier permet d'assembler l'ensemble du navire en toute sécurité.



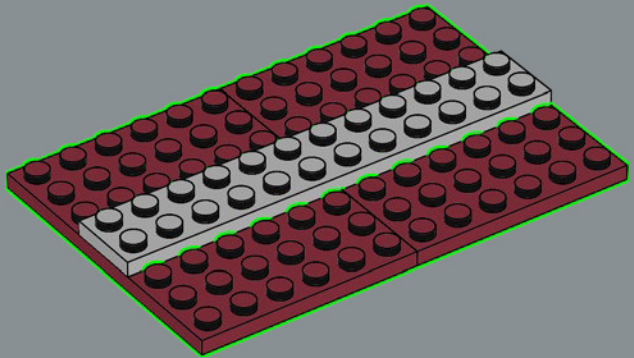
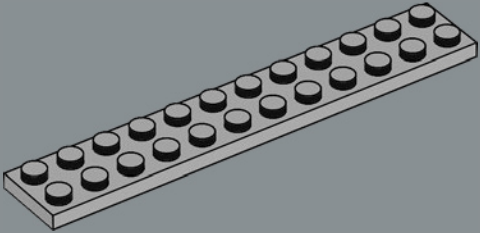
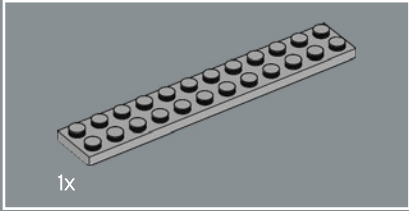
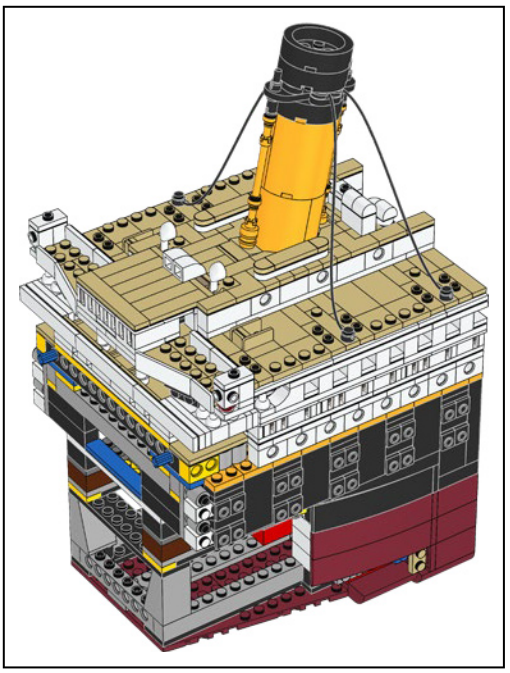
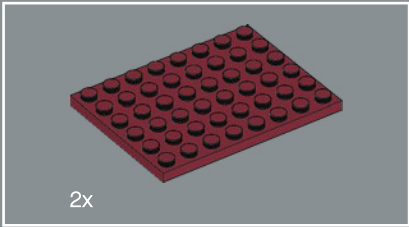
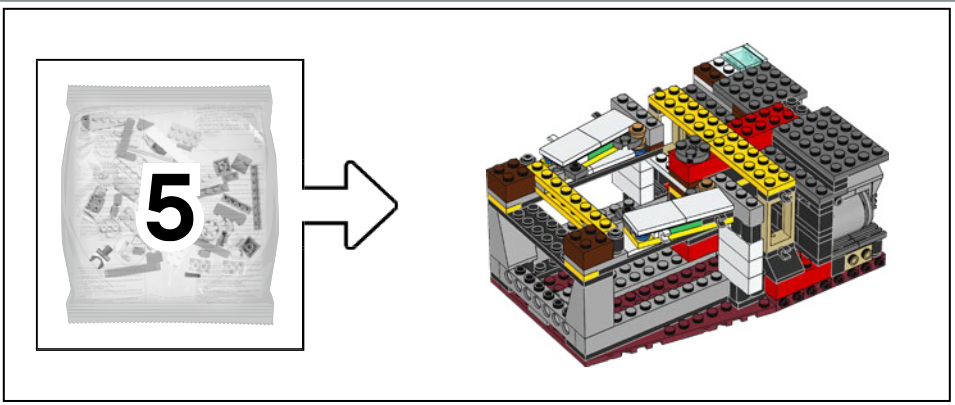



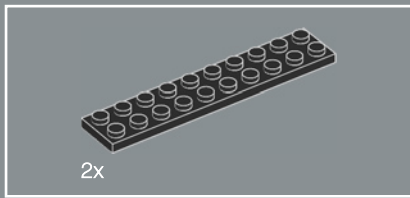

142

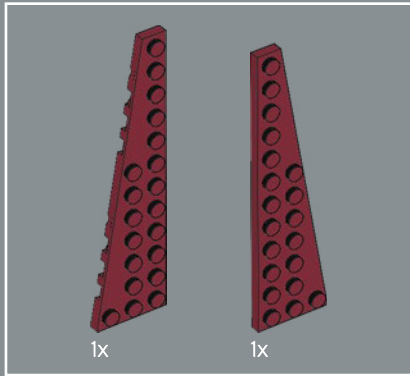
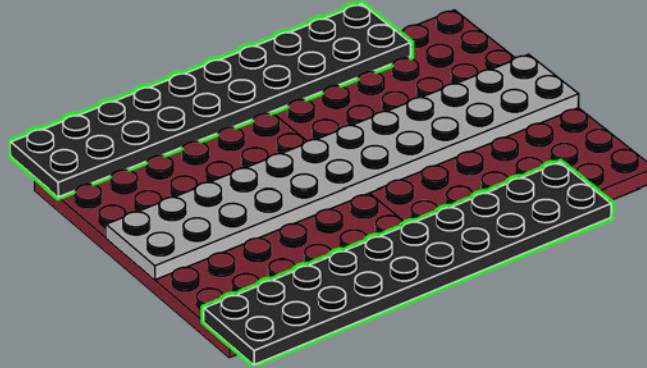

143

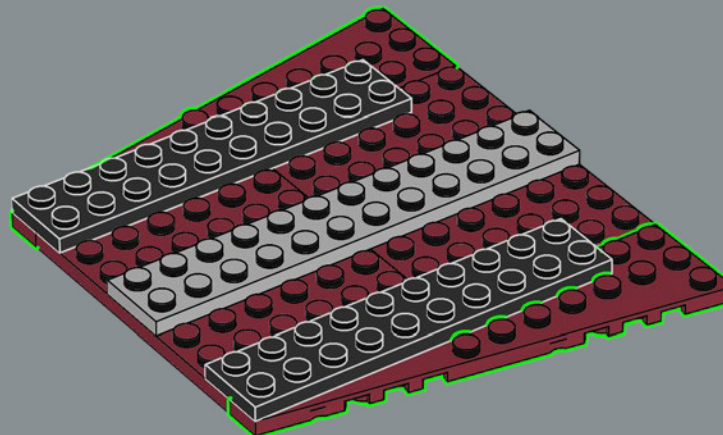

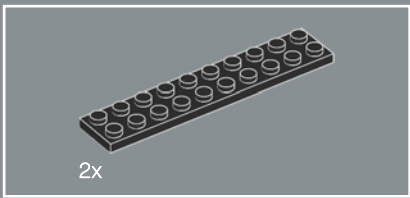

144

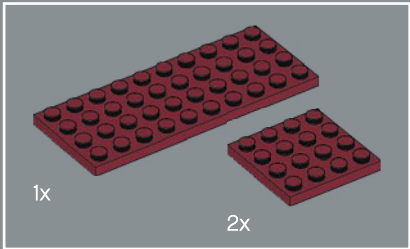
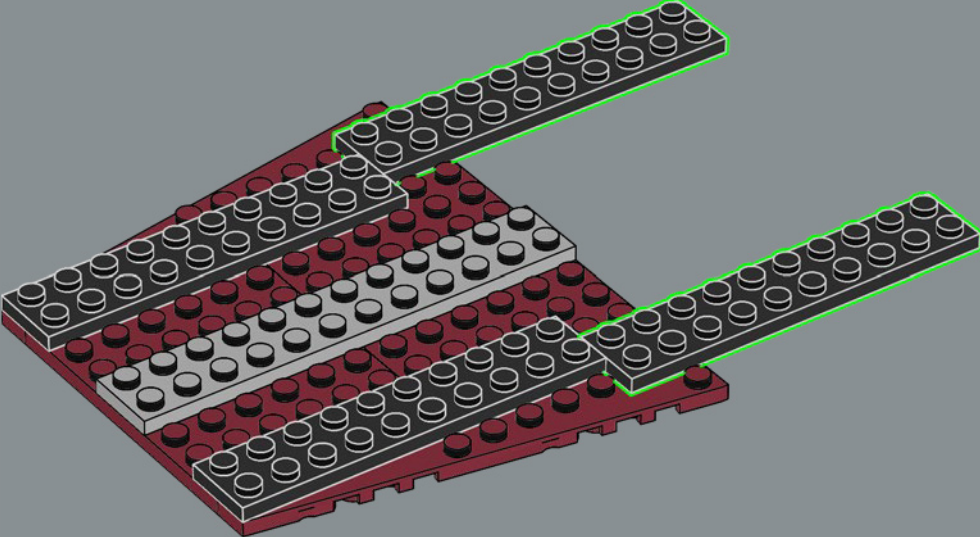

145

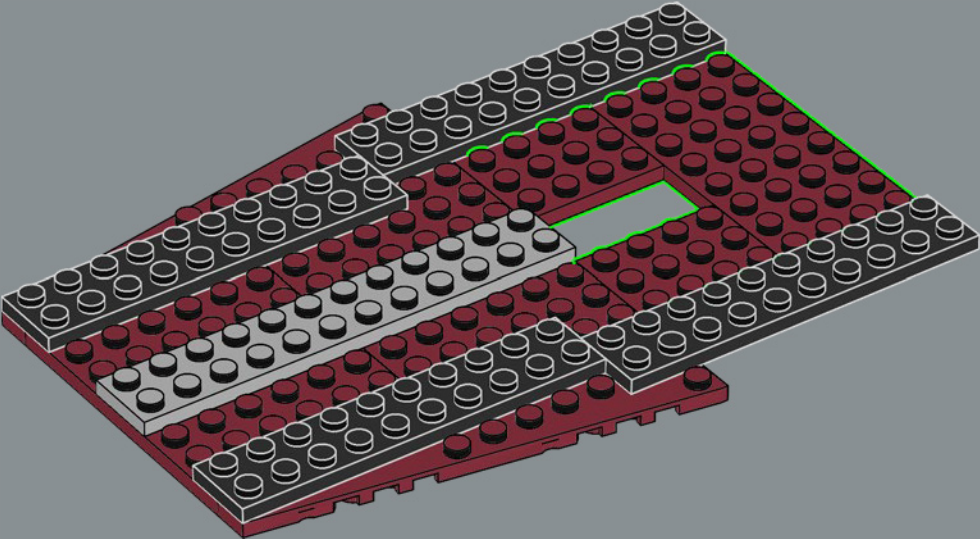

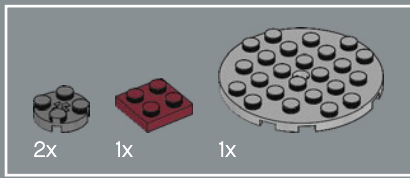

146

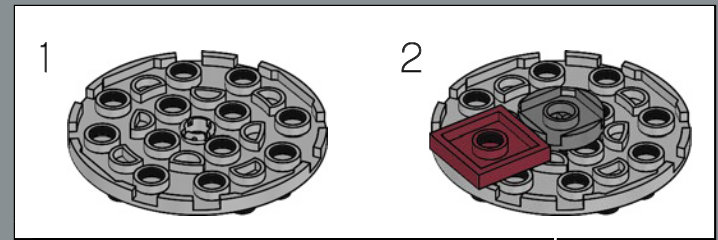
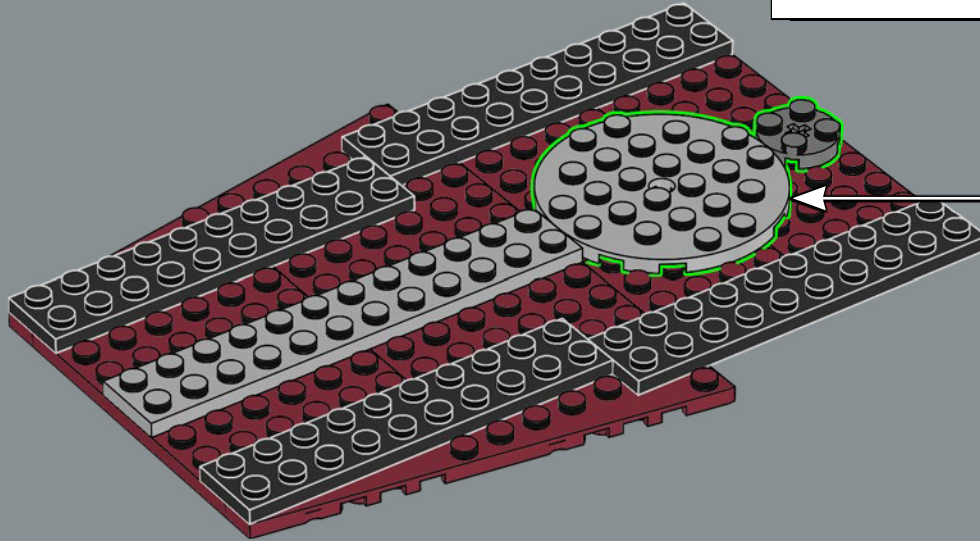

147

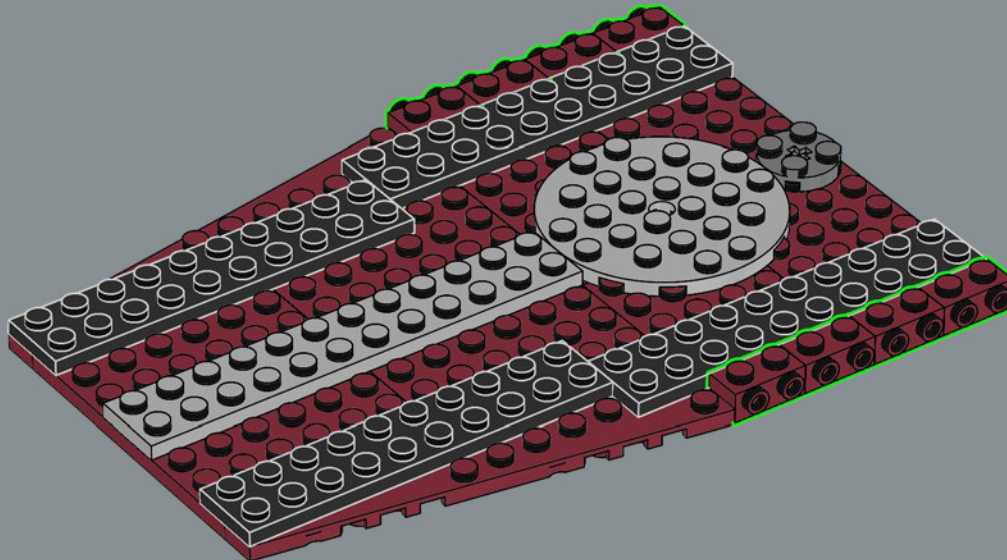

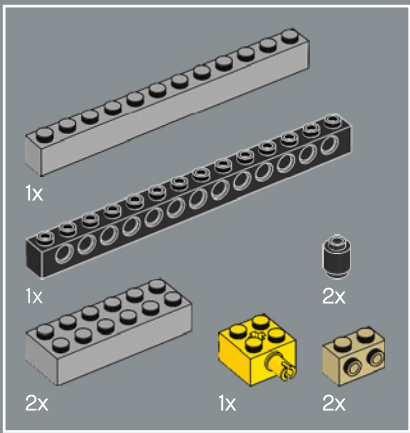

148

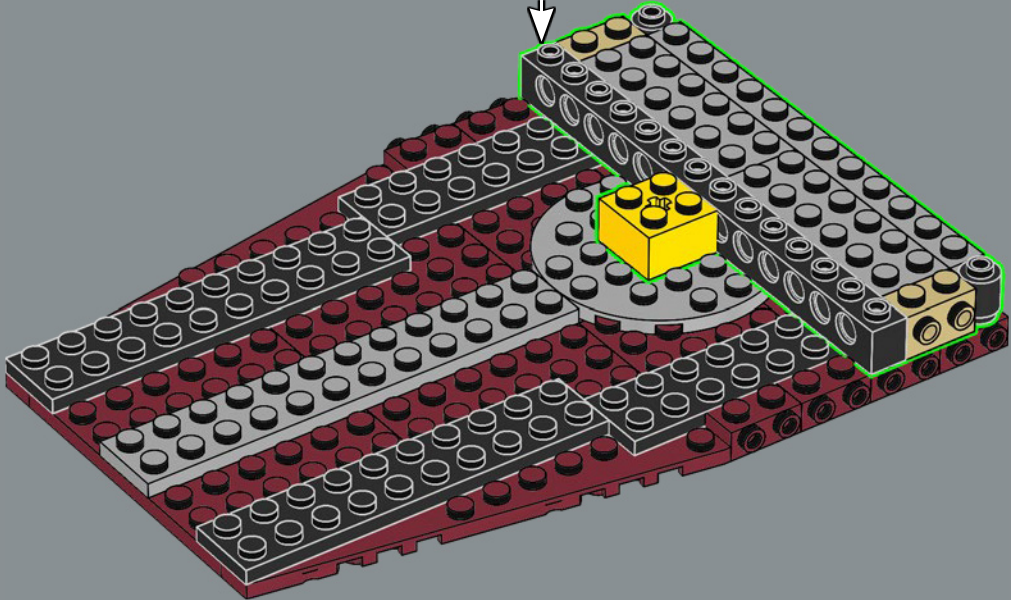
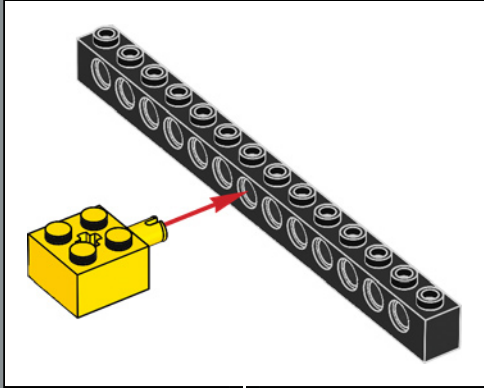

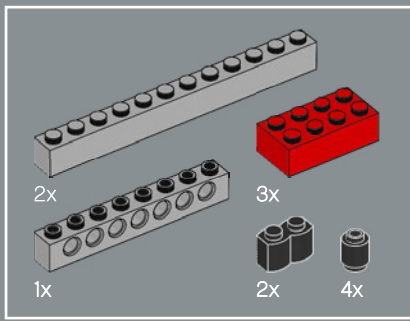

149

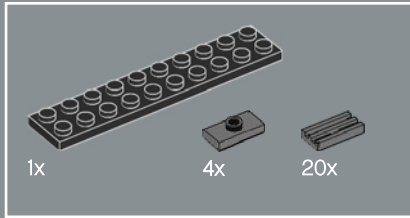
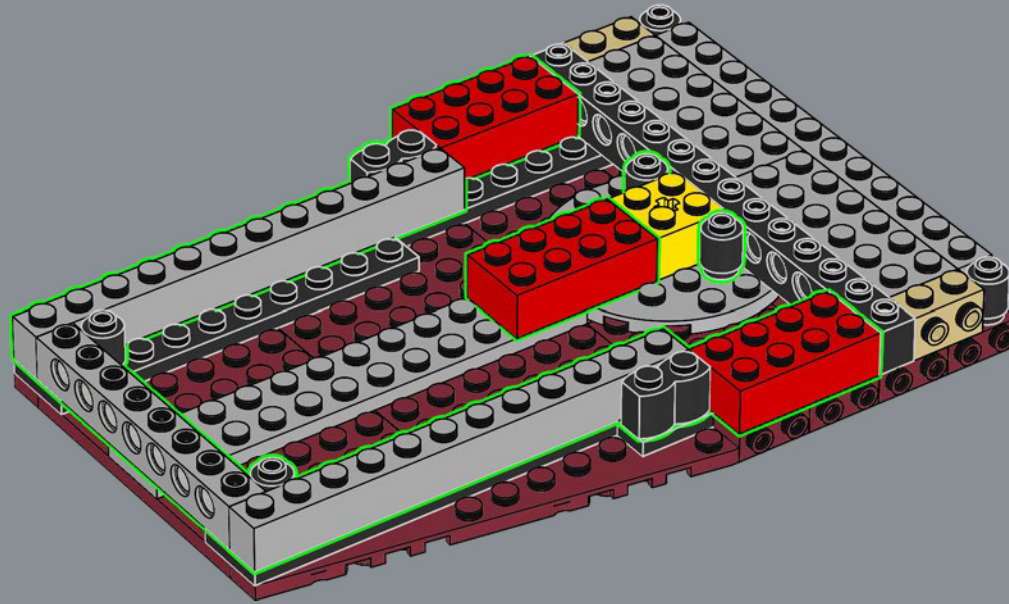

150

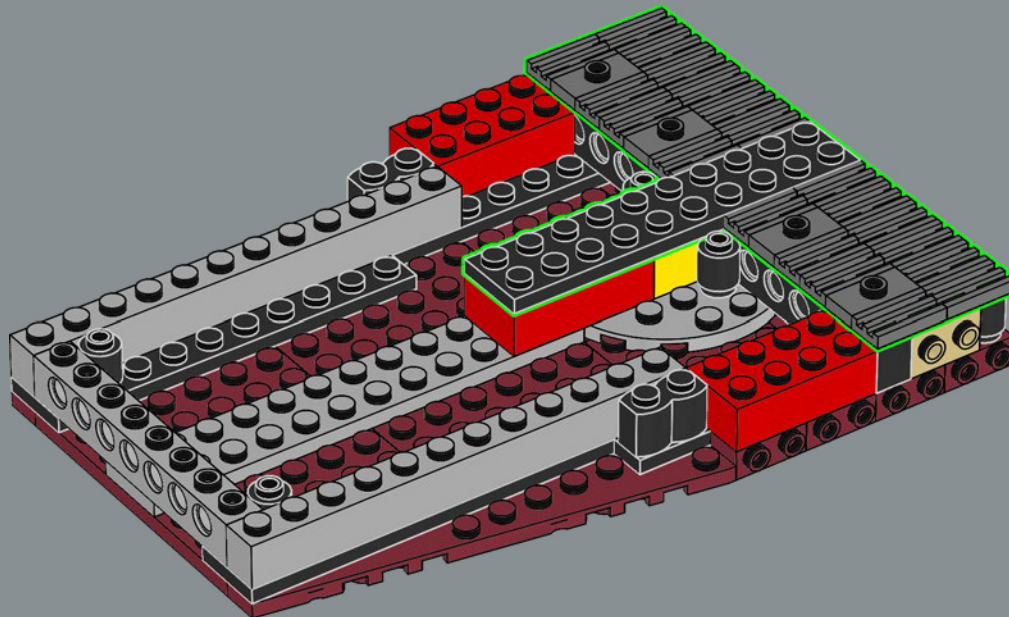

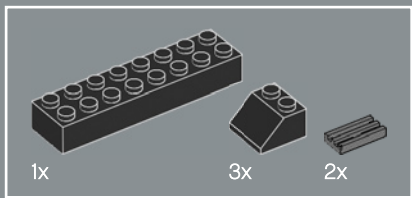

151

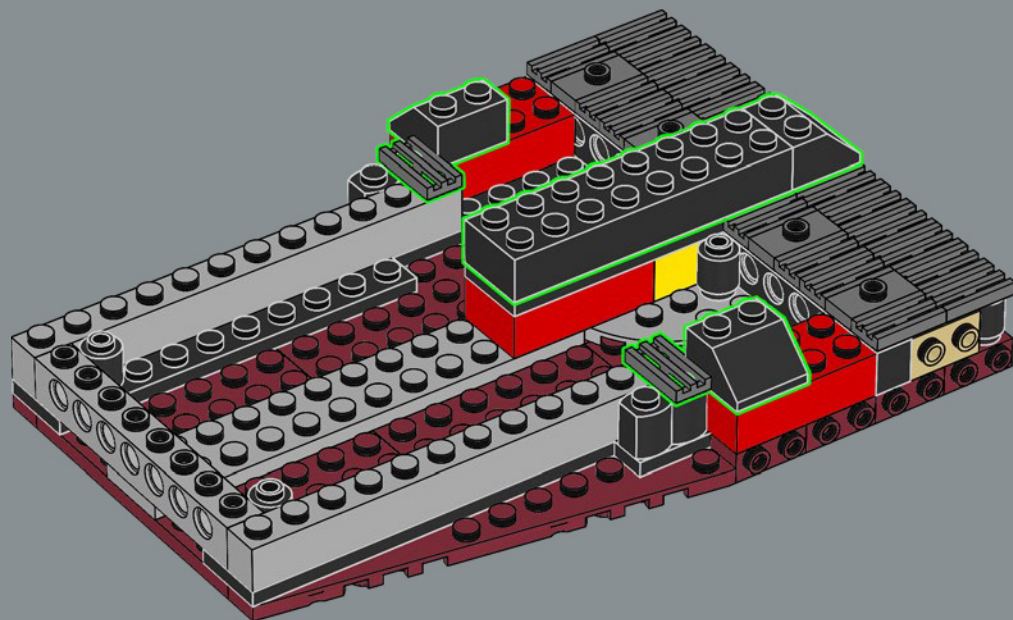

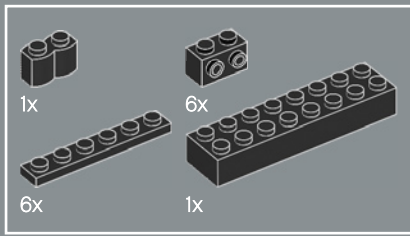

152

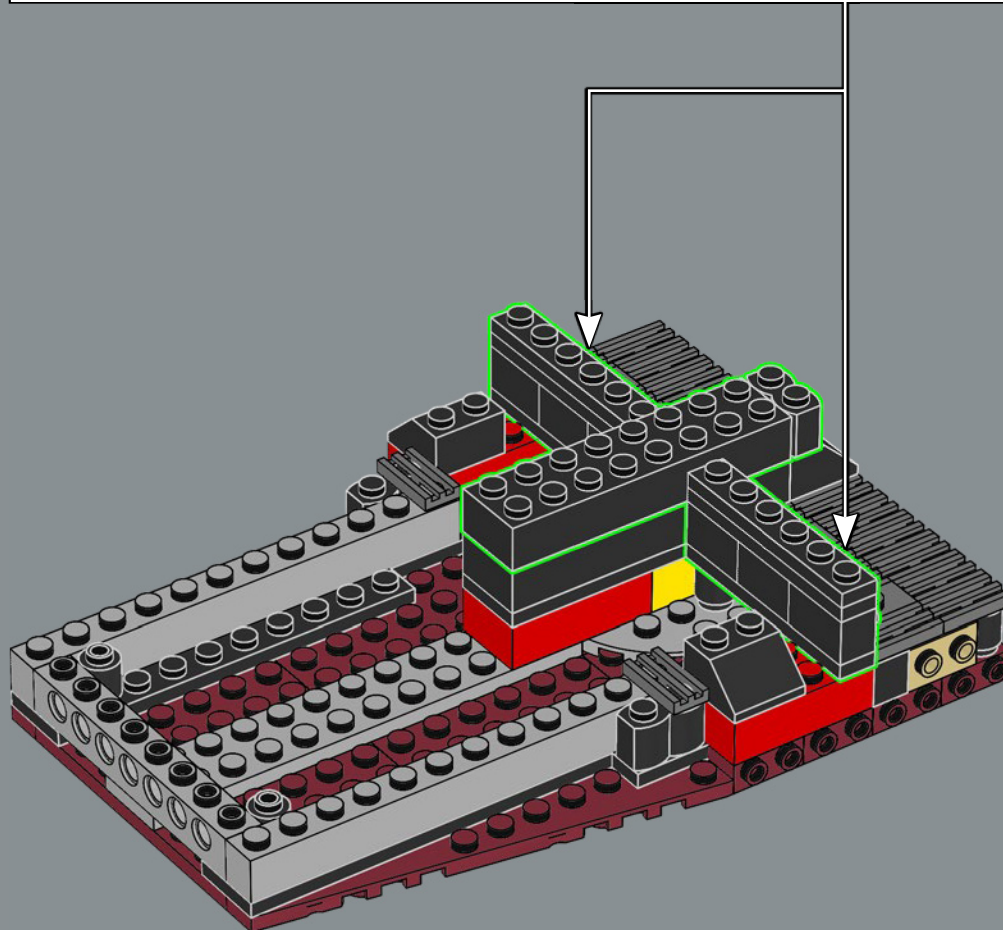
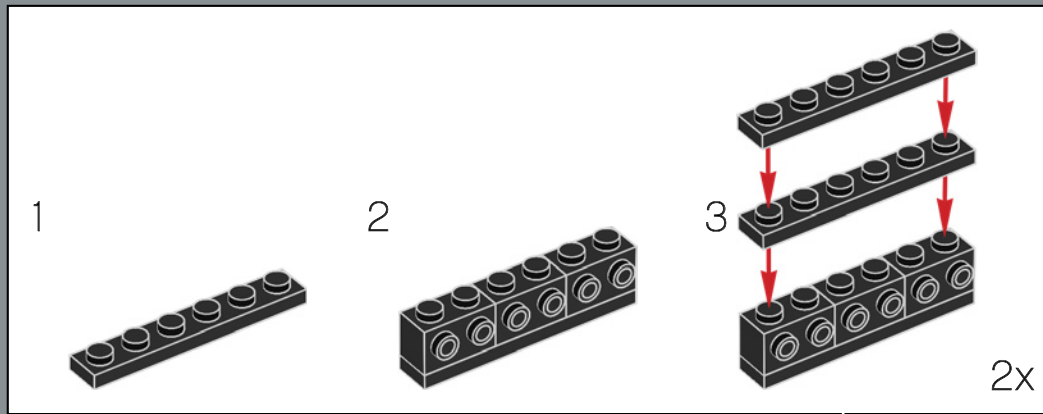

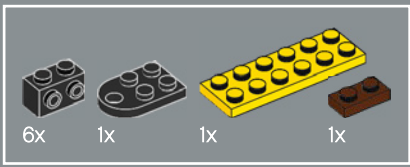

153

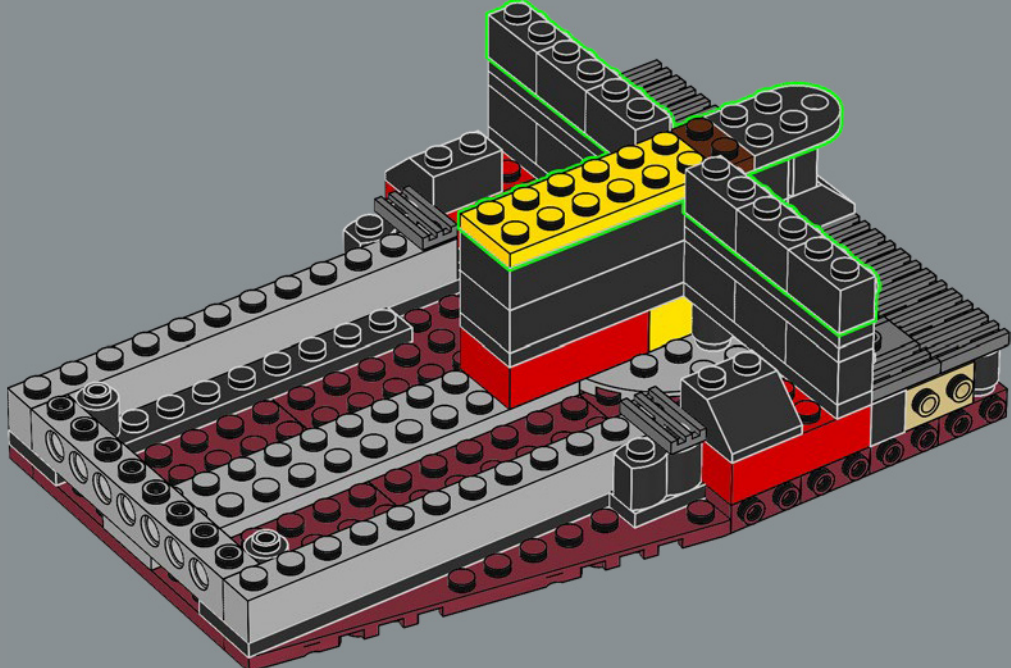



175 chauffeurs travaillent jour et nuit pour alimenter en charbon les chaudières des moteurs.

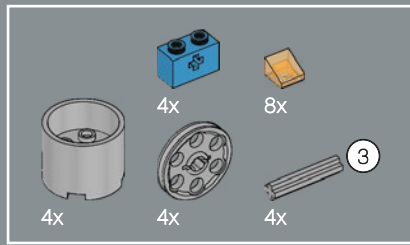

154

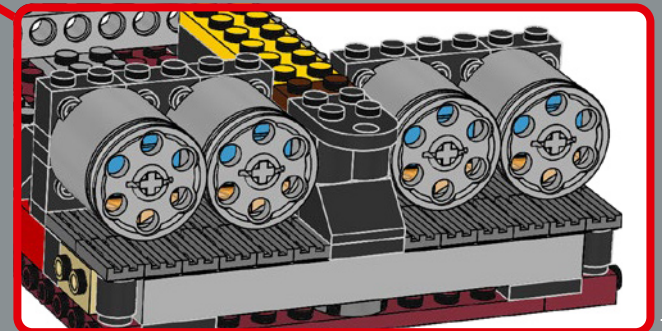
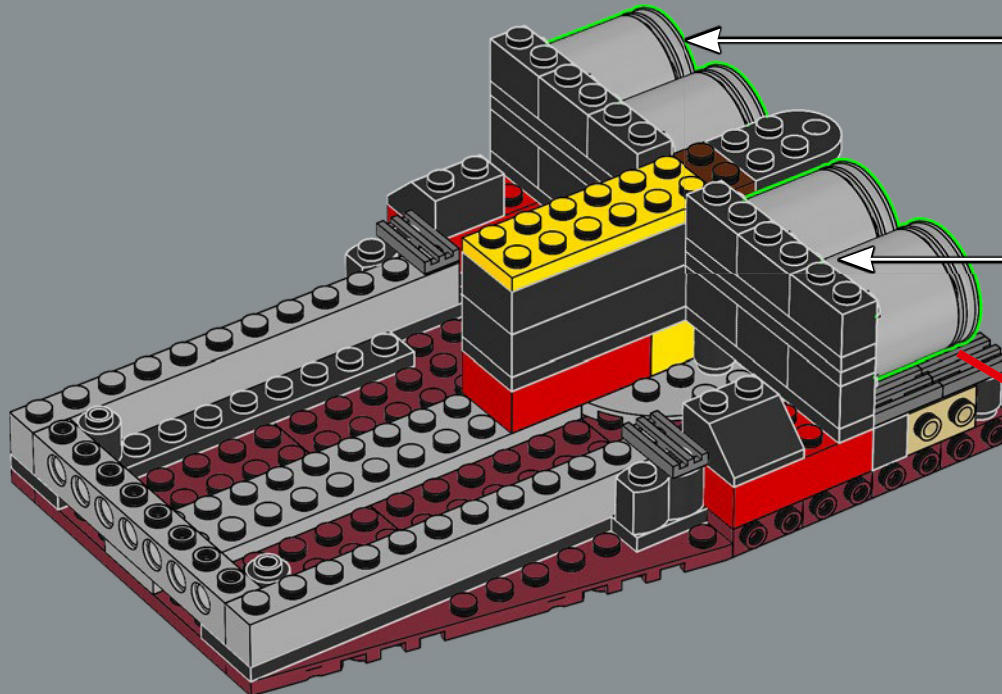
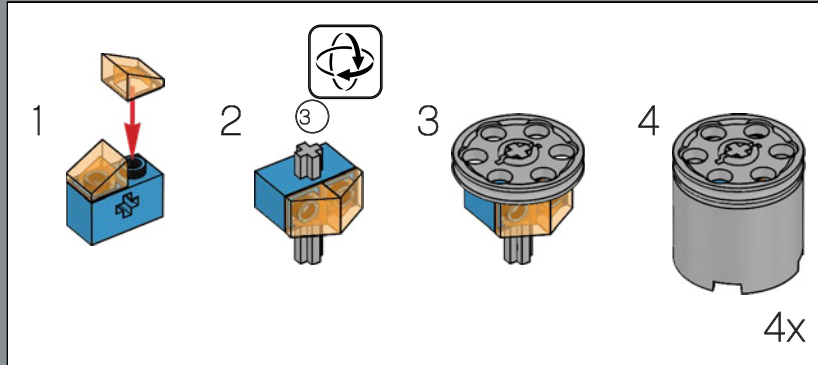

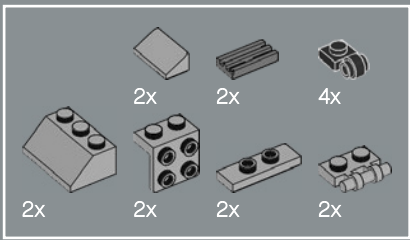

155

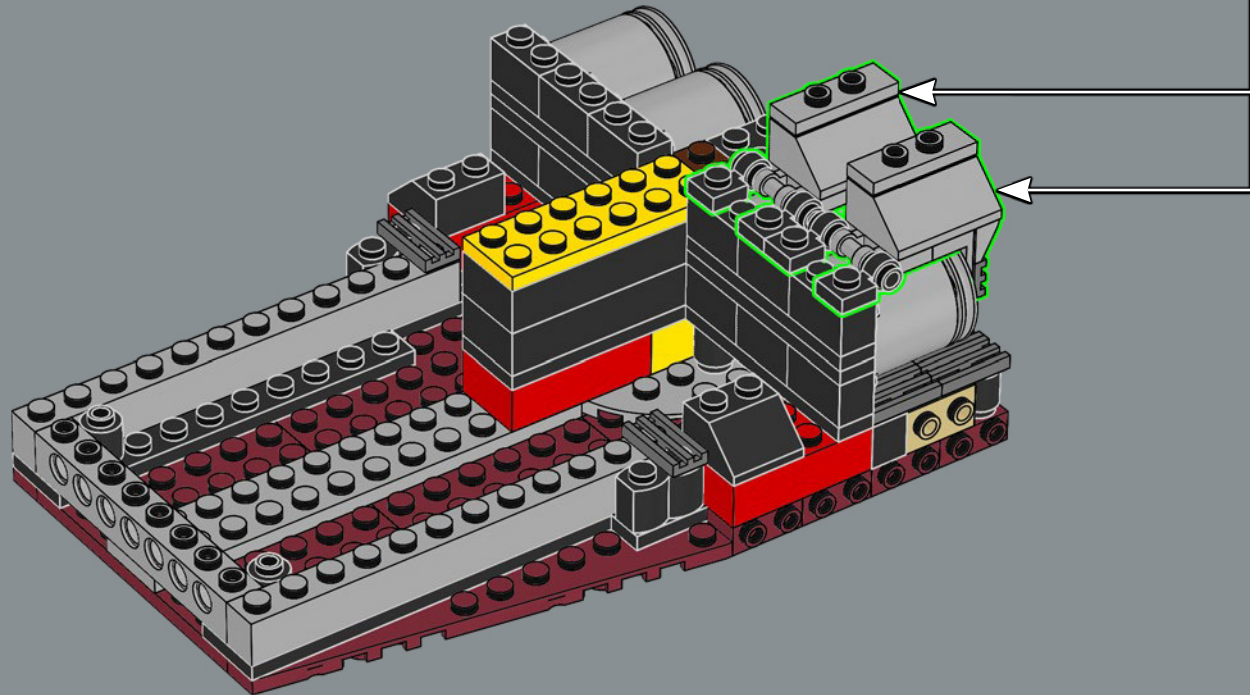
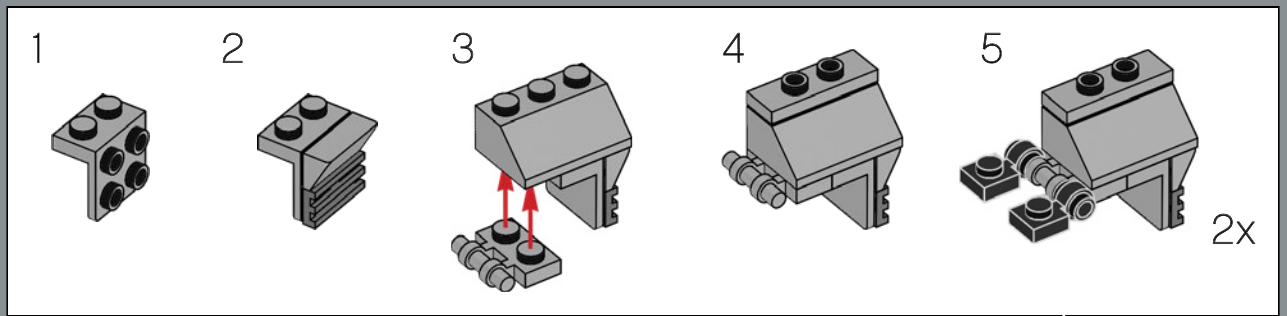

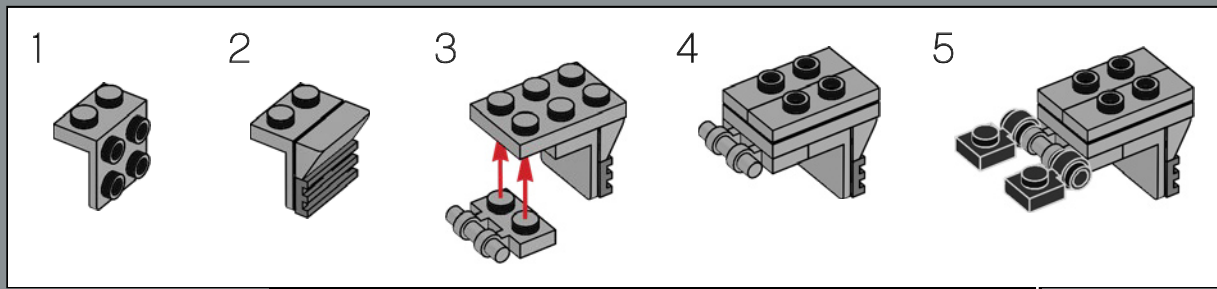
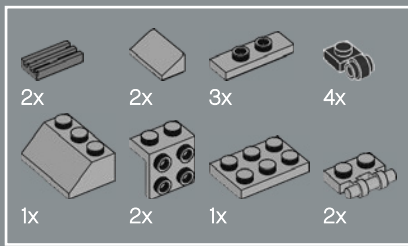

156

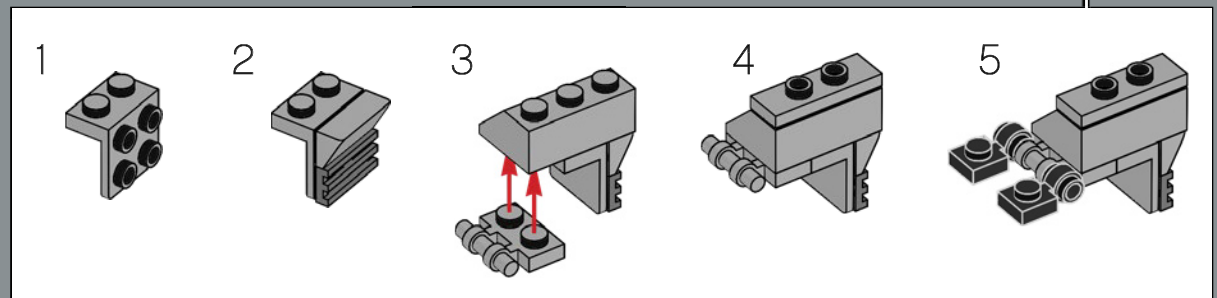
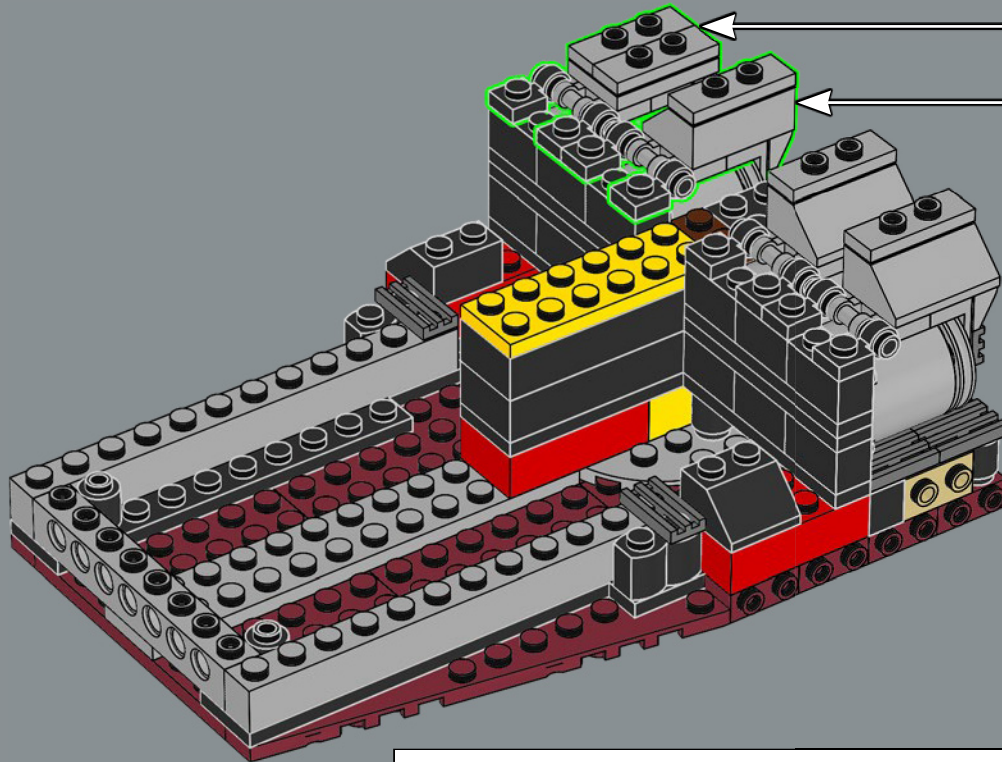

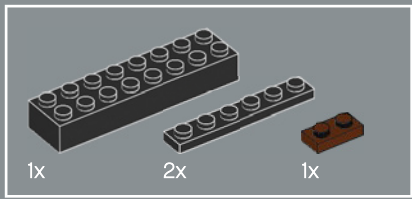

157

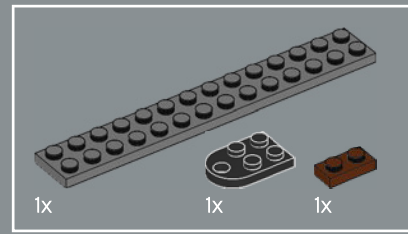
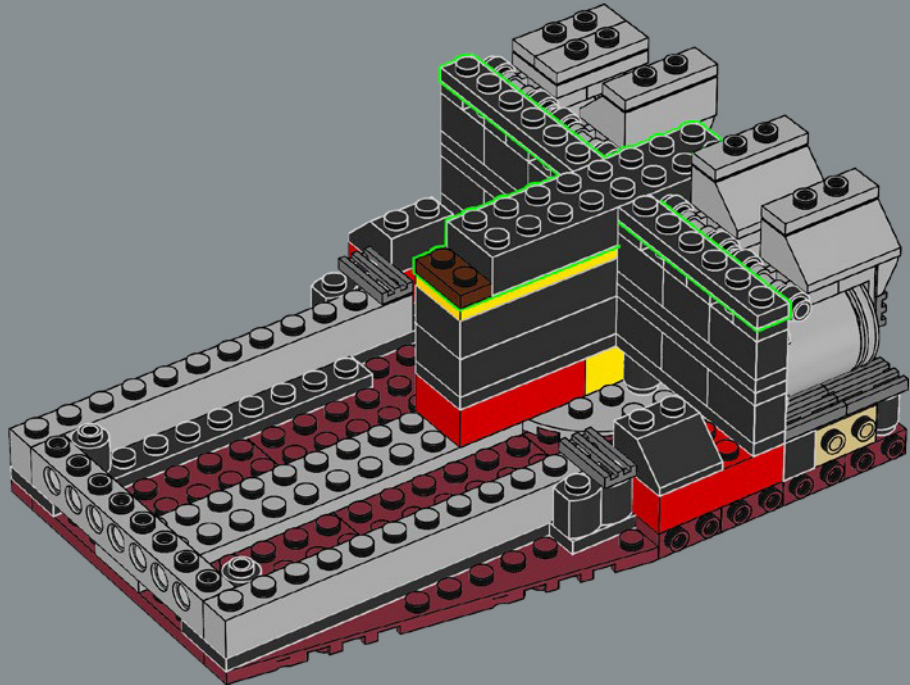

158

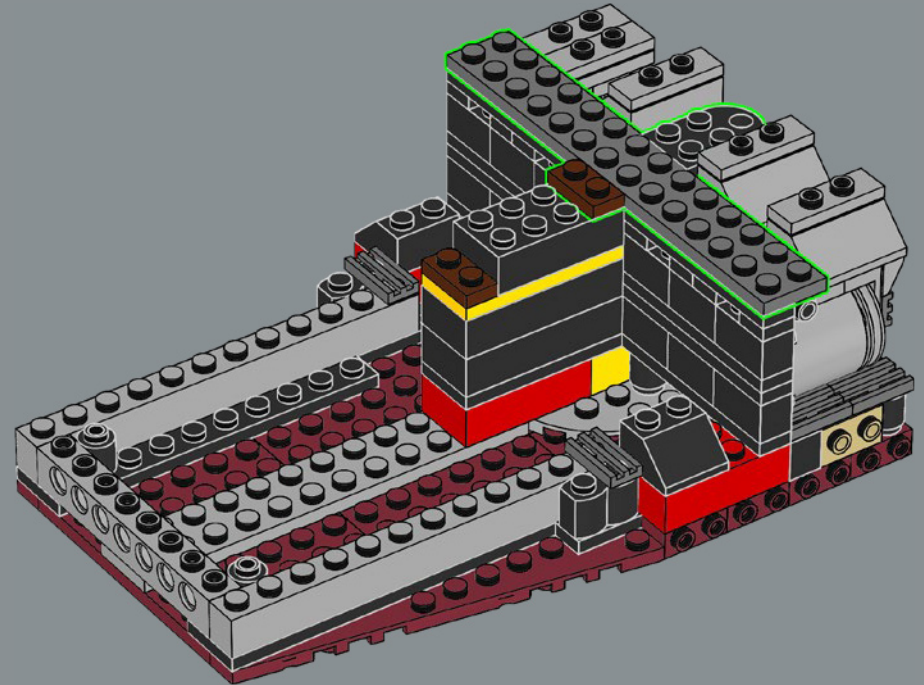

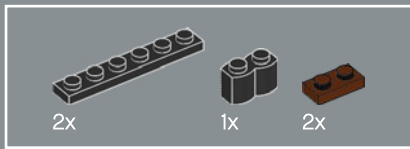

159

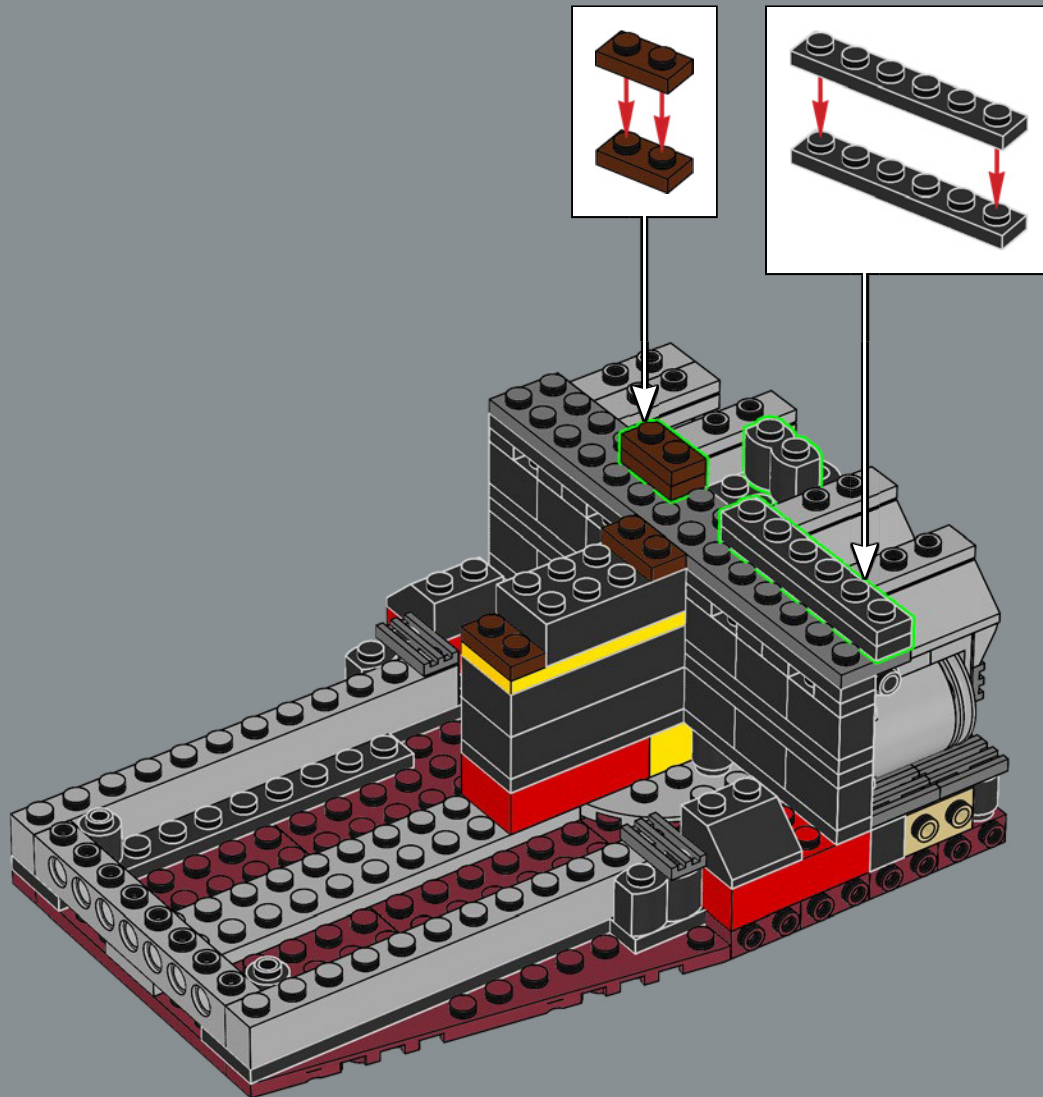

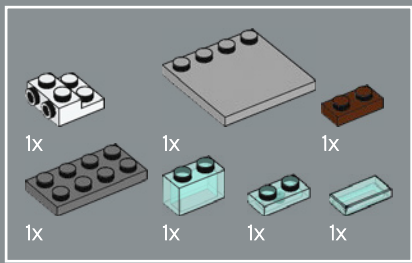

160

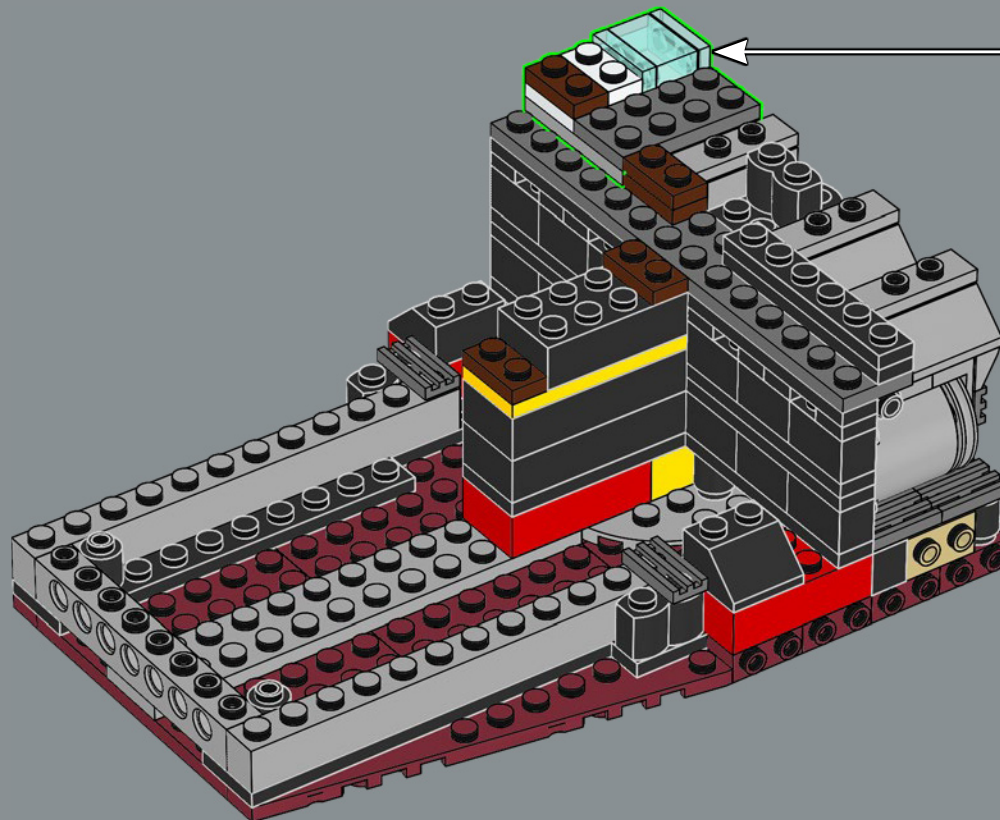
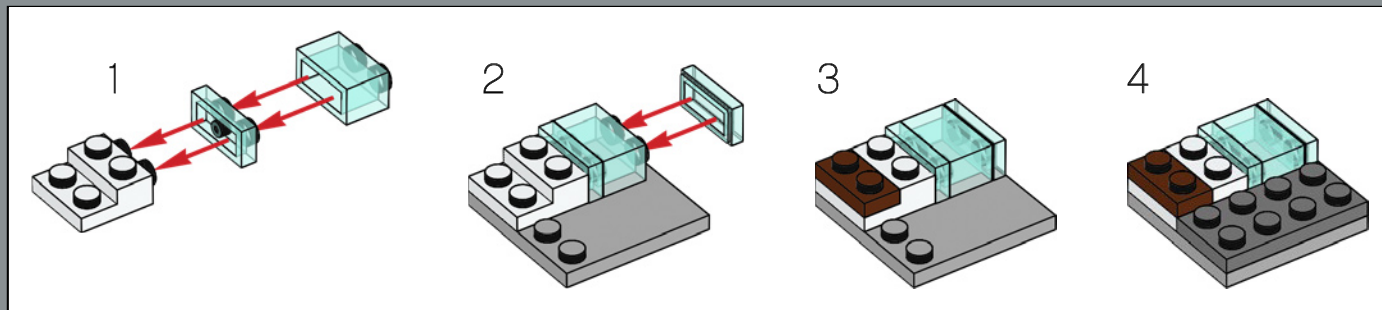

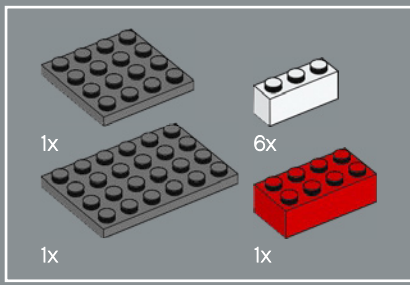

161

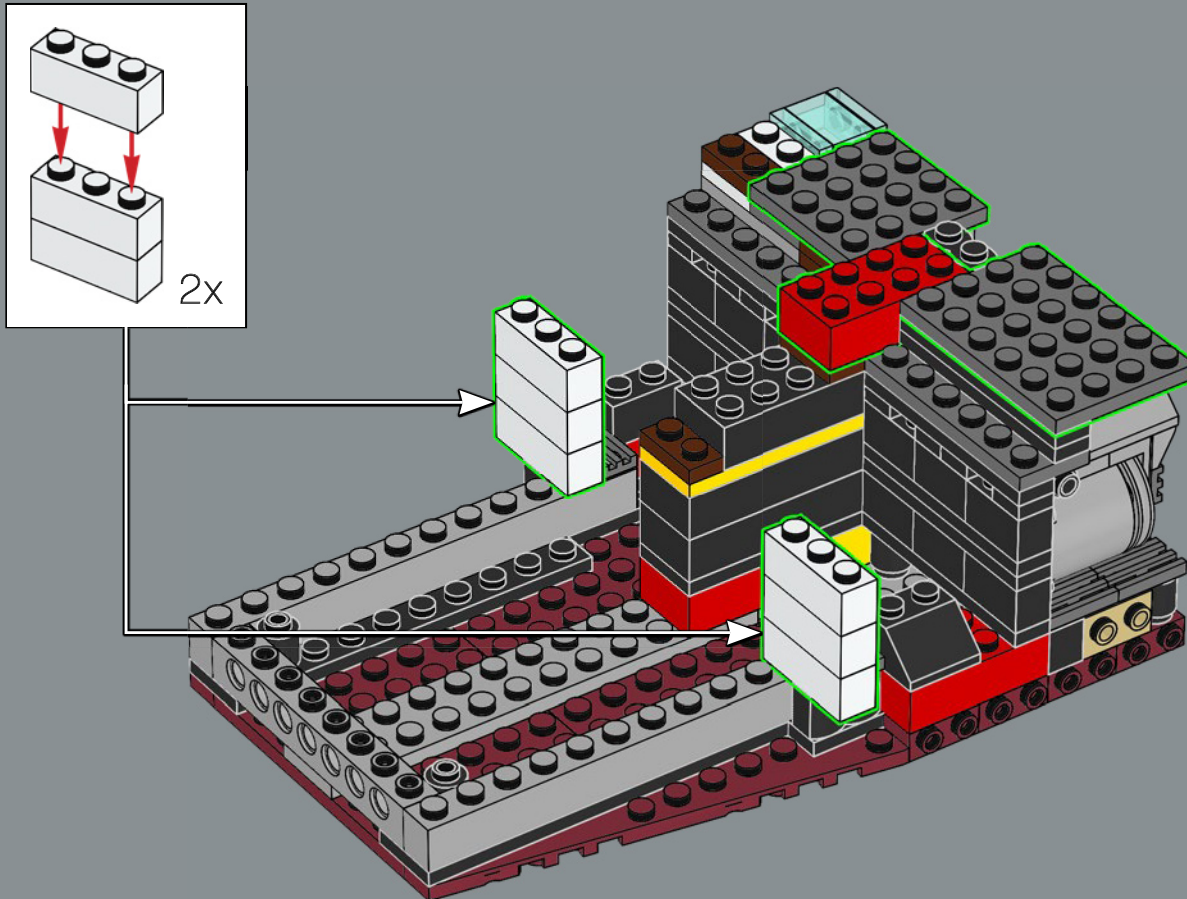

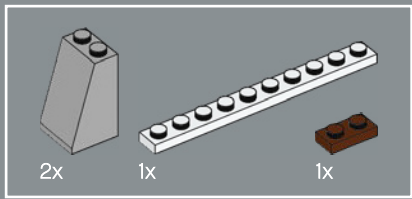

162

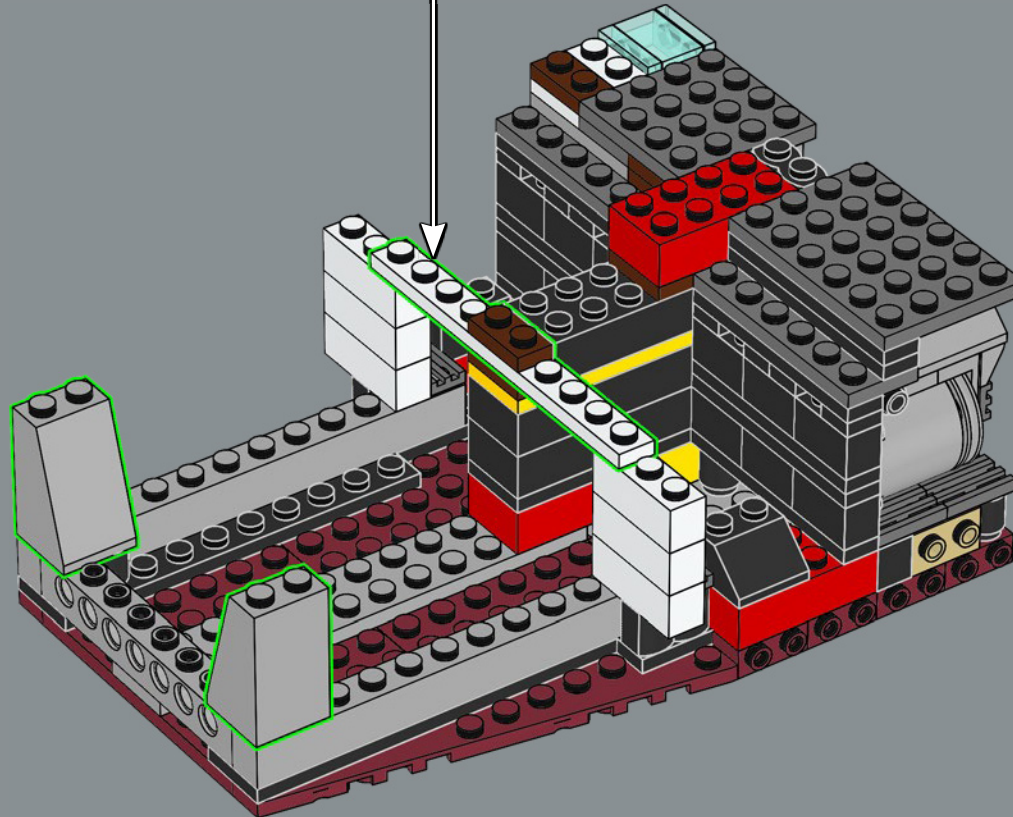
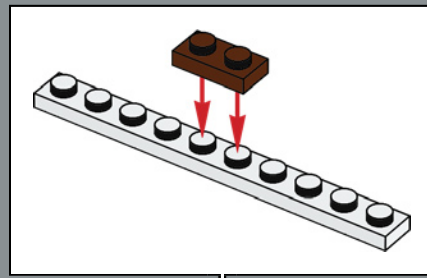



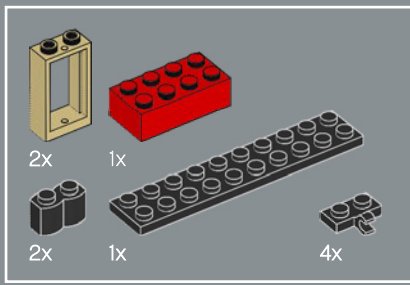

163

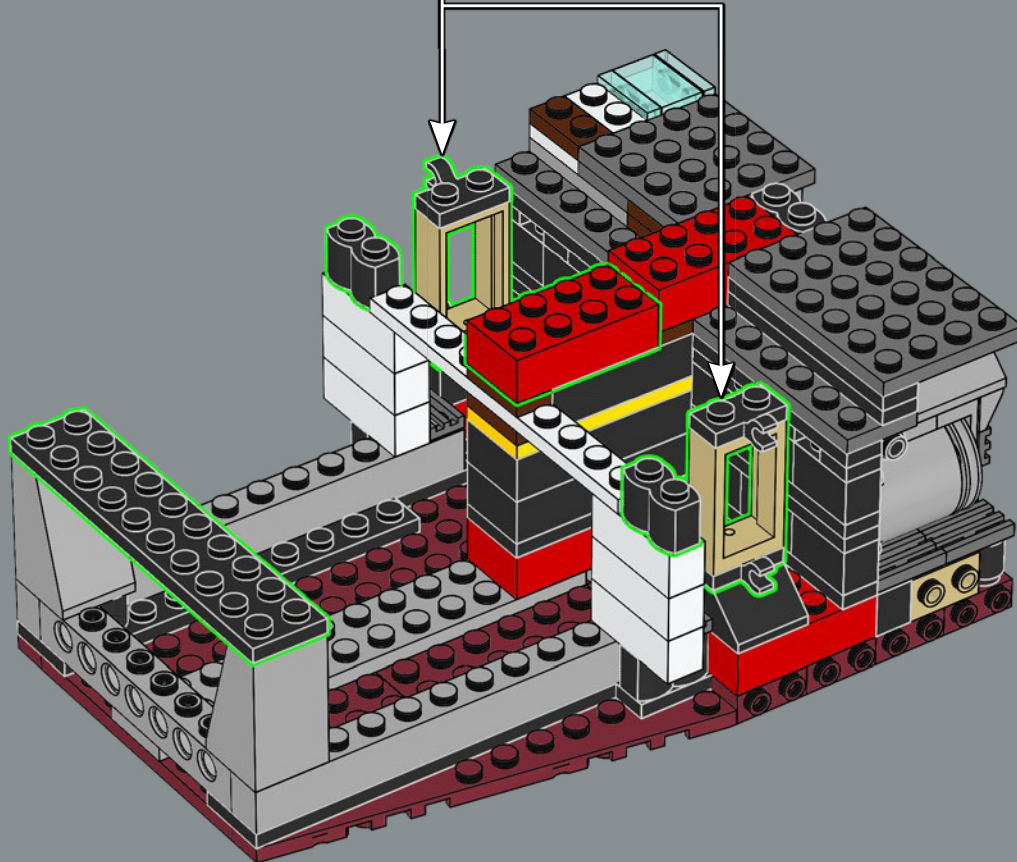
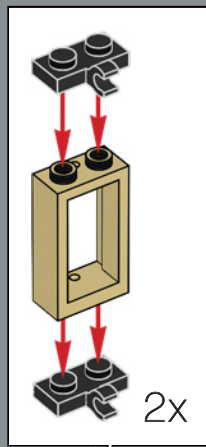

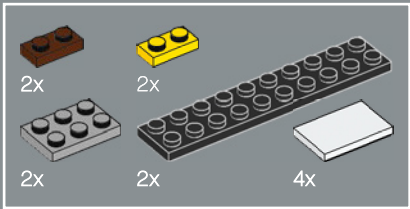

164

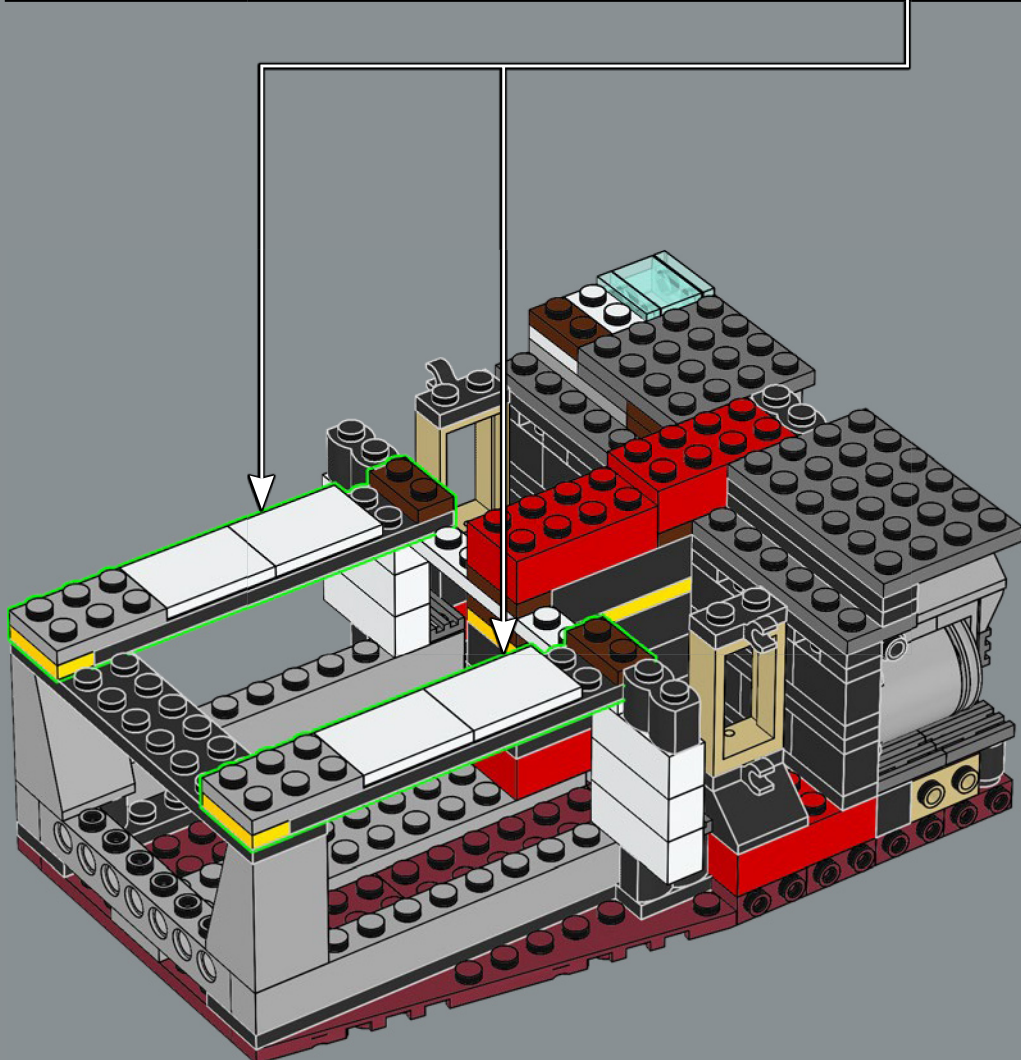
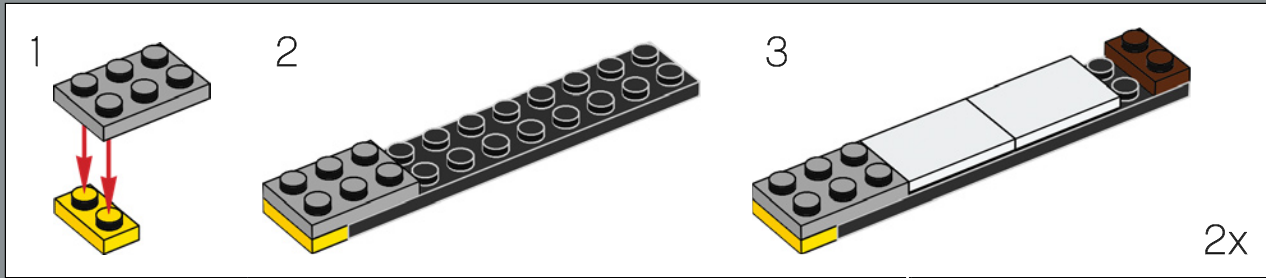

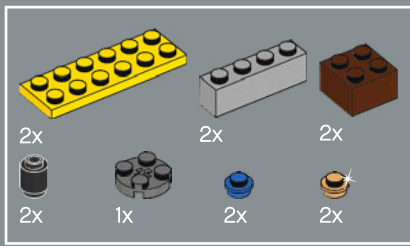

165

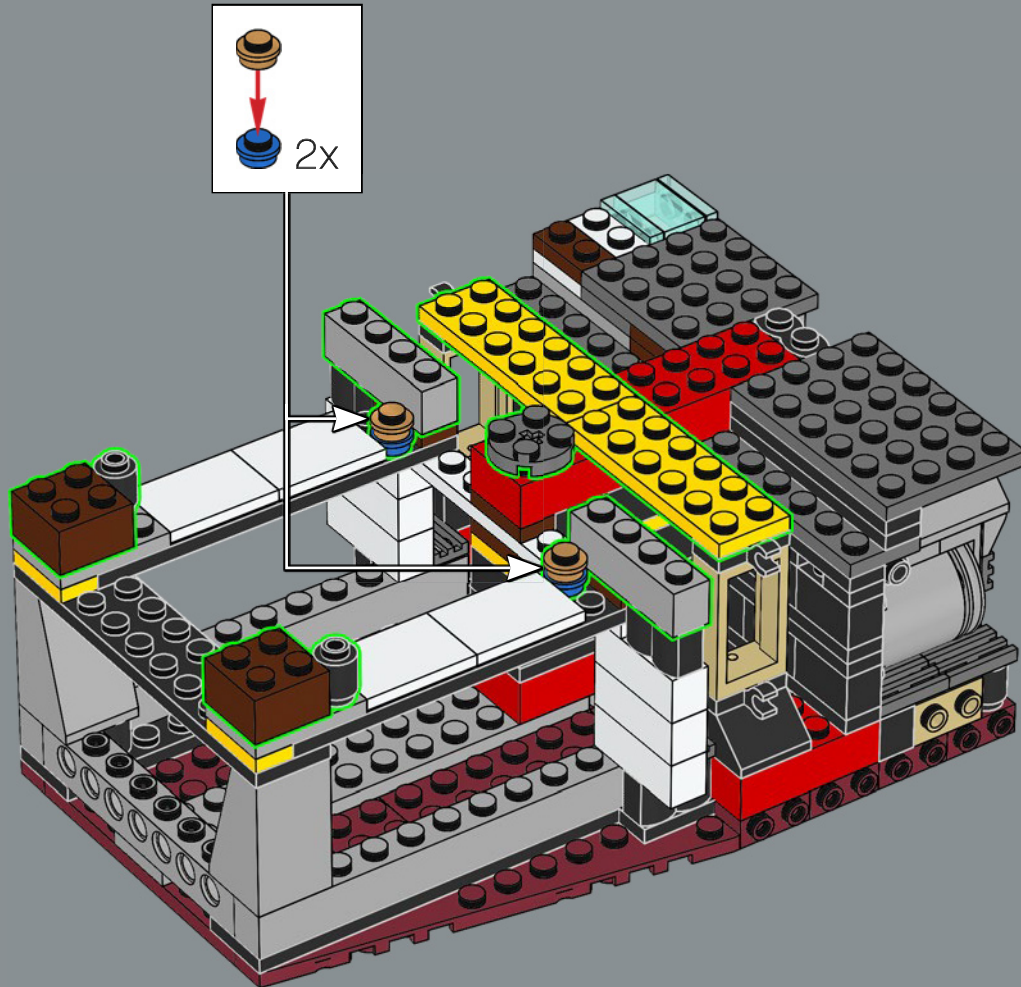

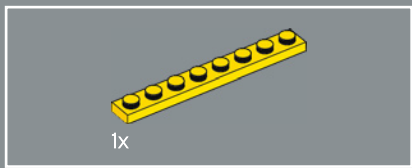

166

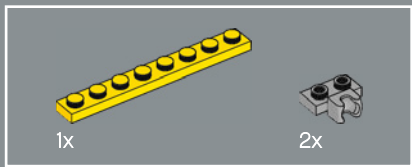
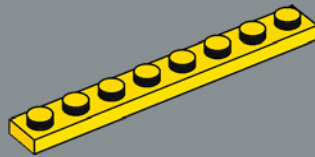

167

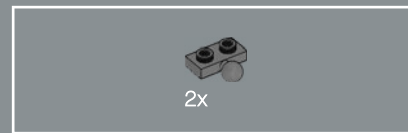
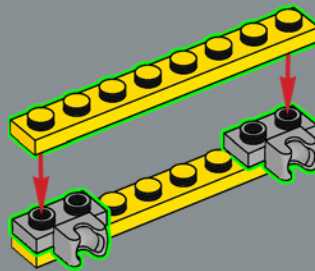

168

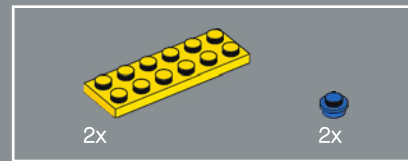
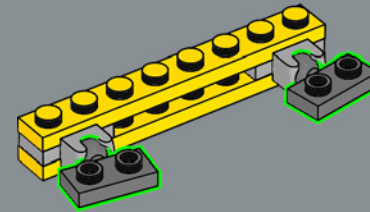

169

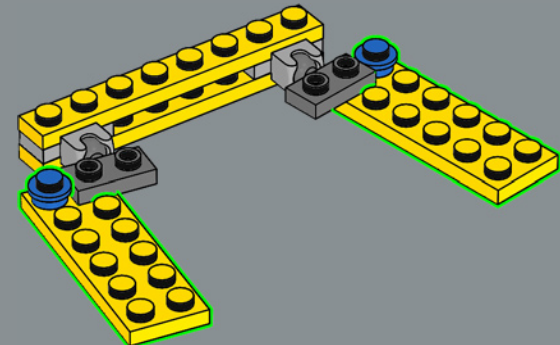

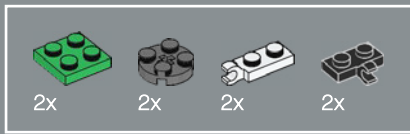

170

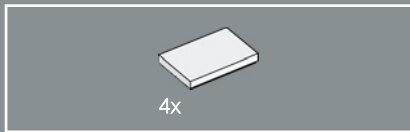
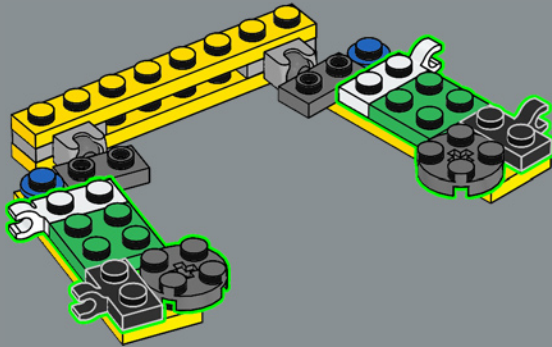

171

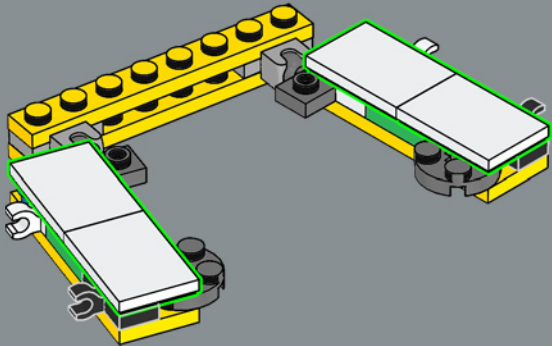

172

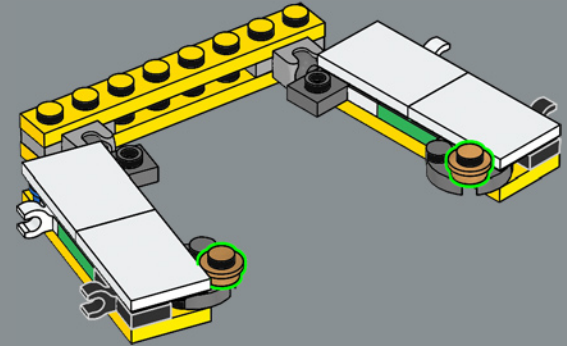

173

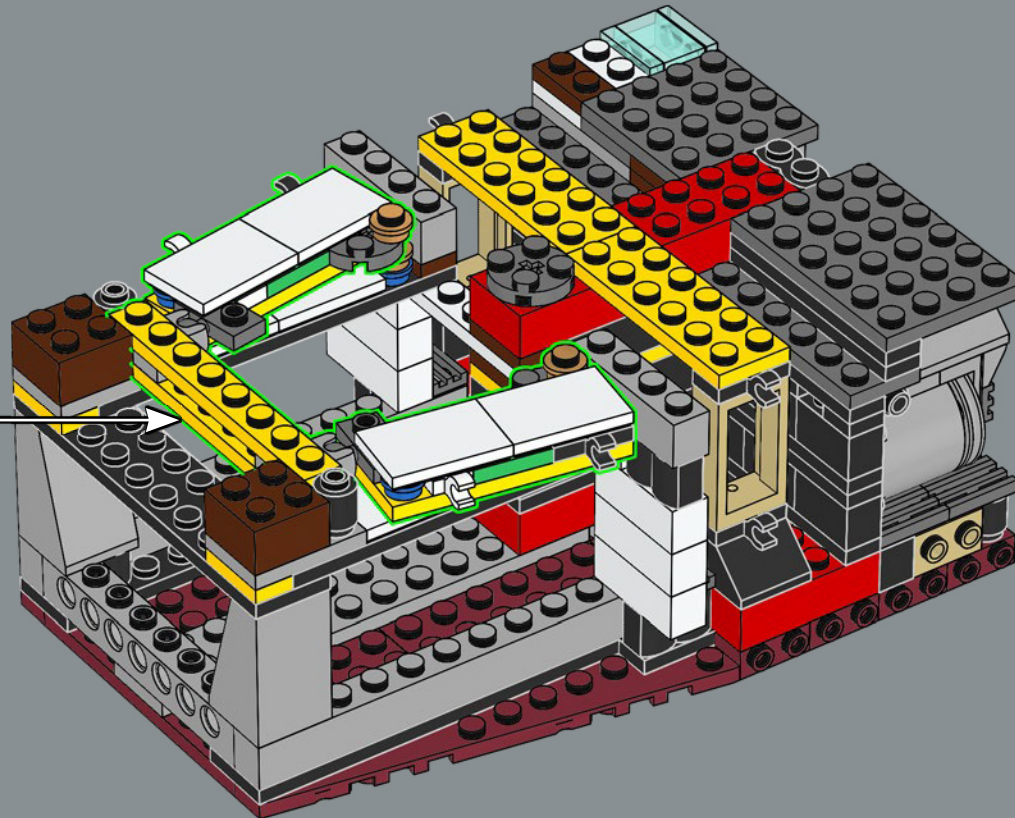

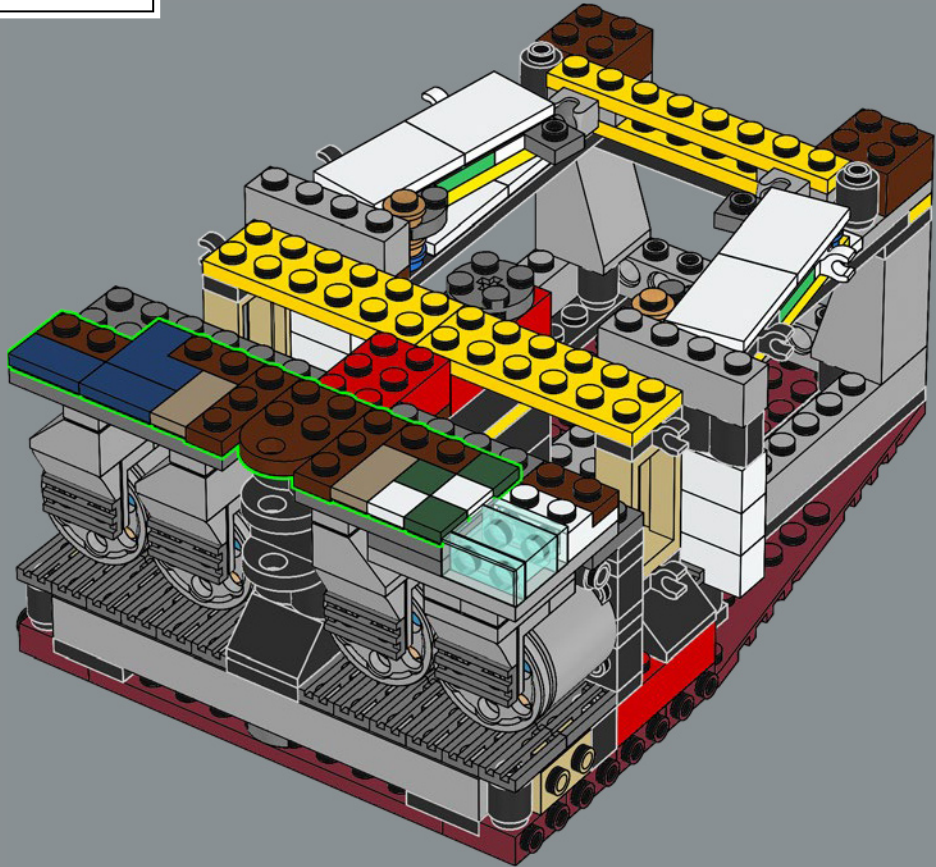
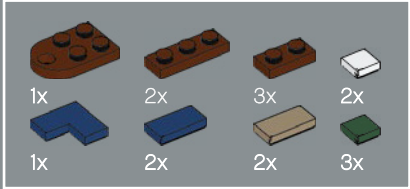
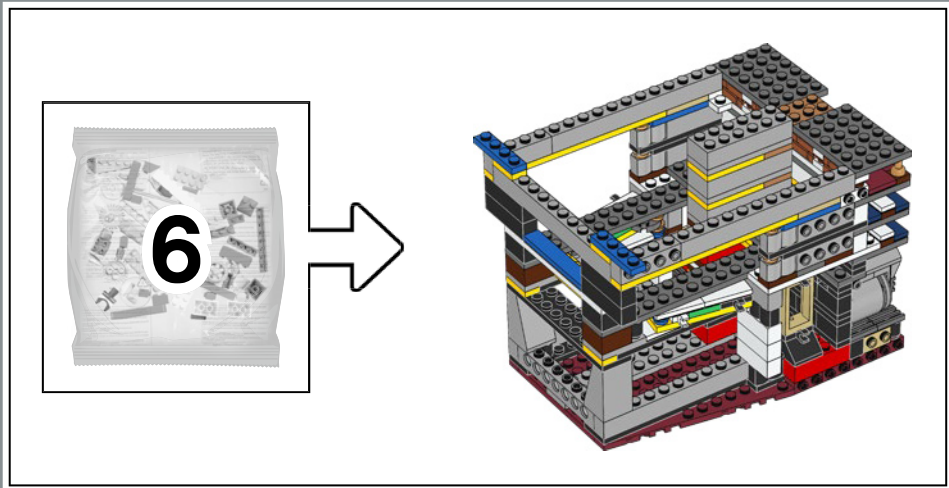

174

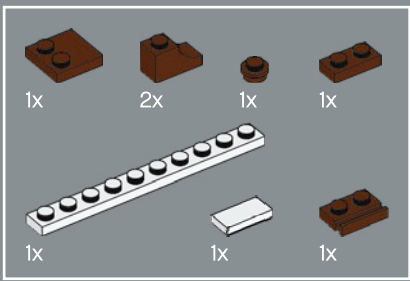

175

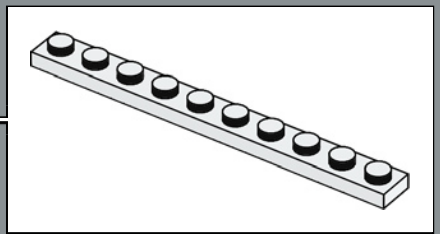
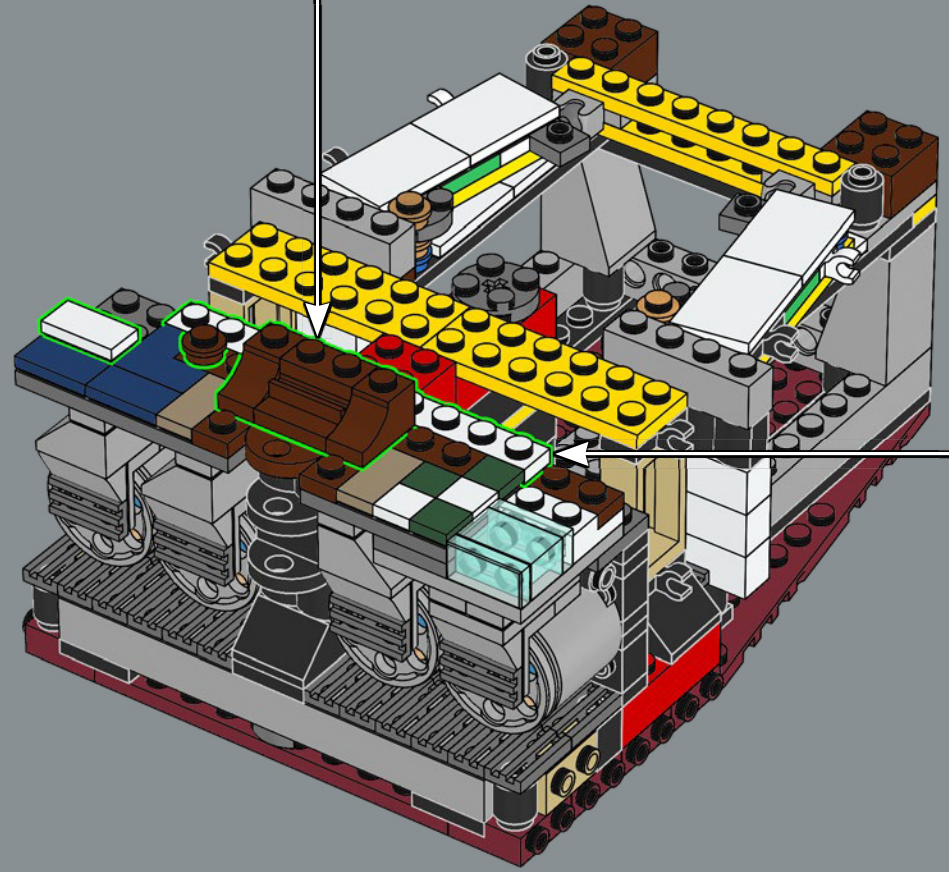
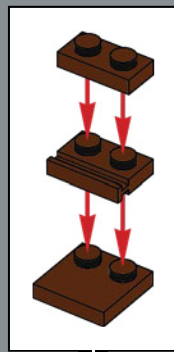





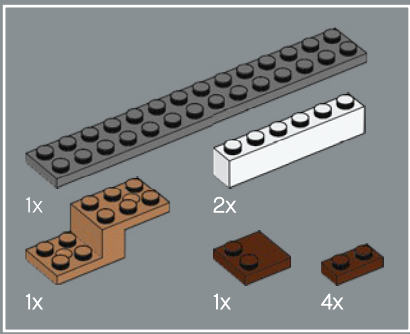

177

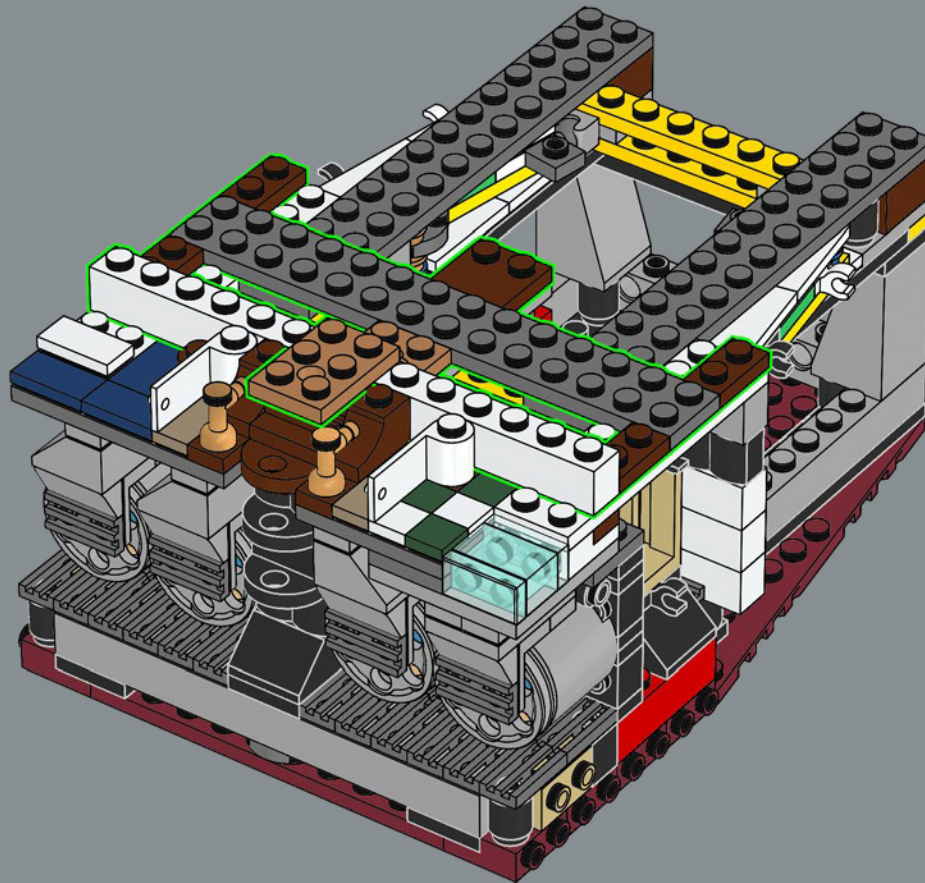

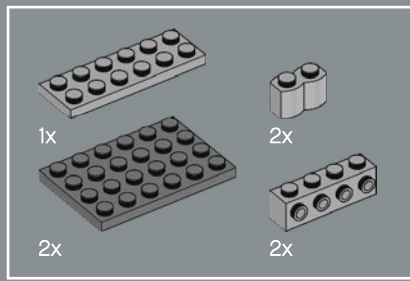

178

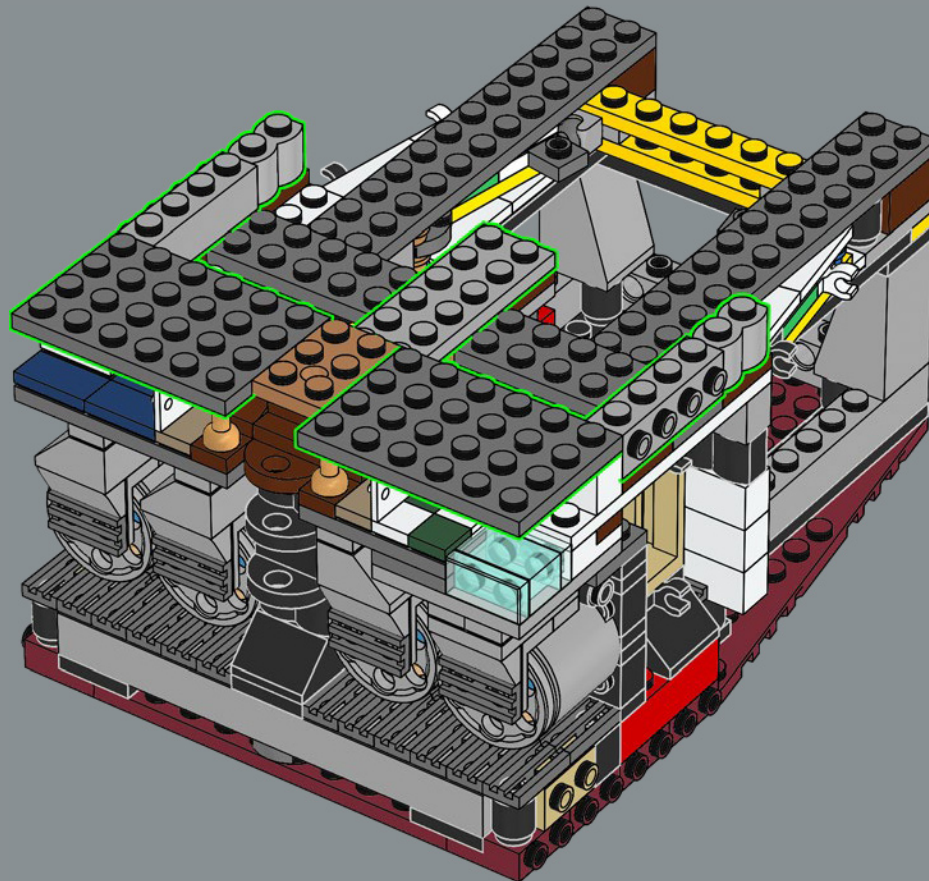

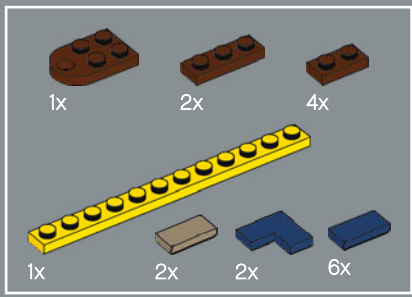

179

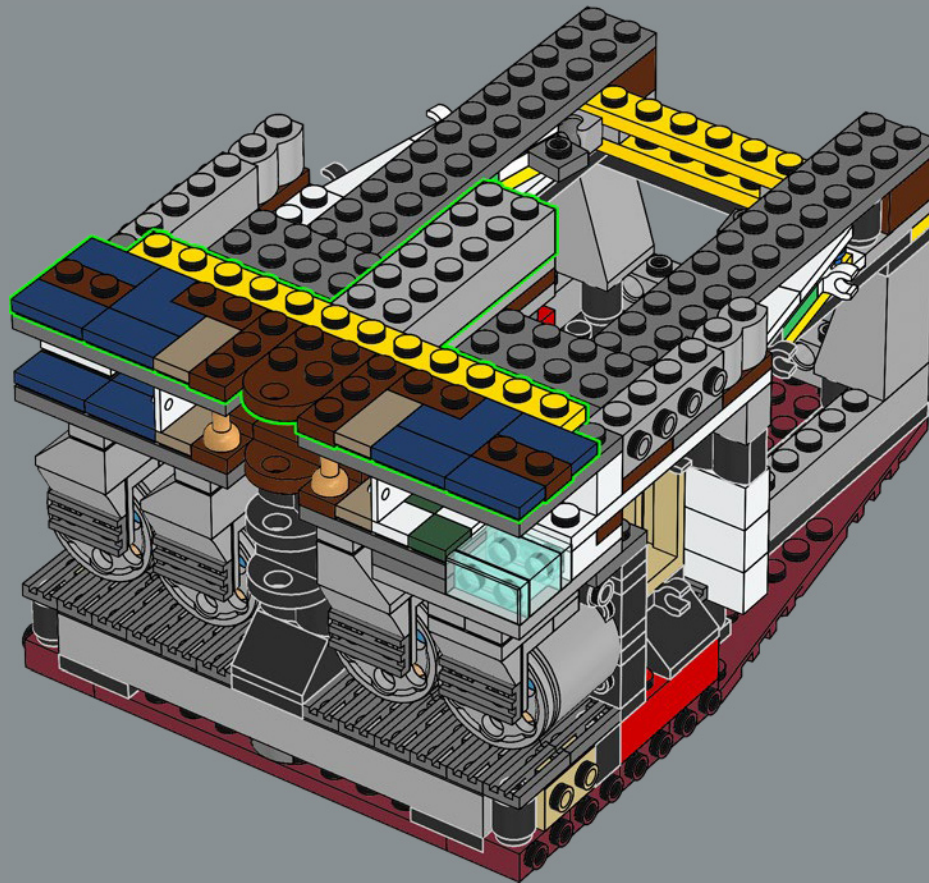



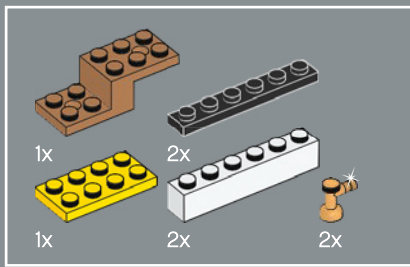

181

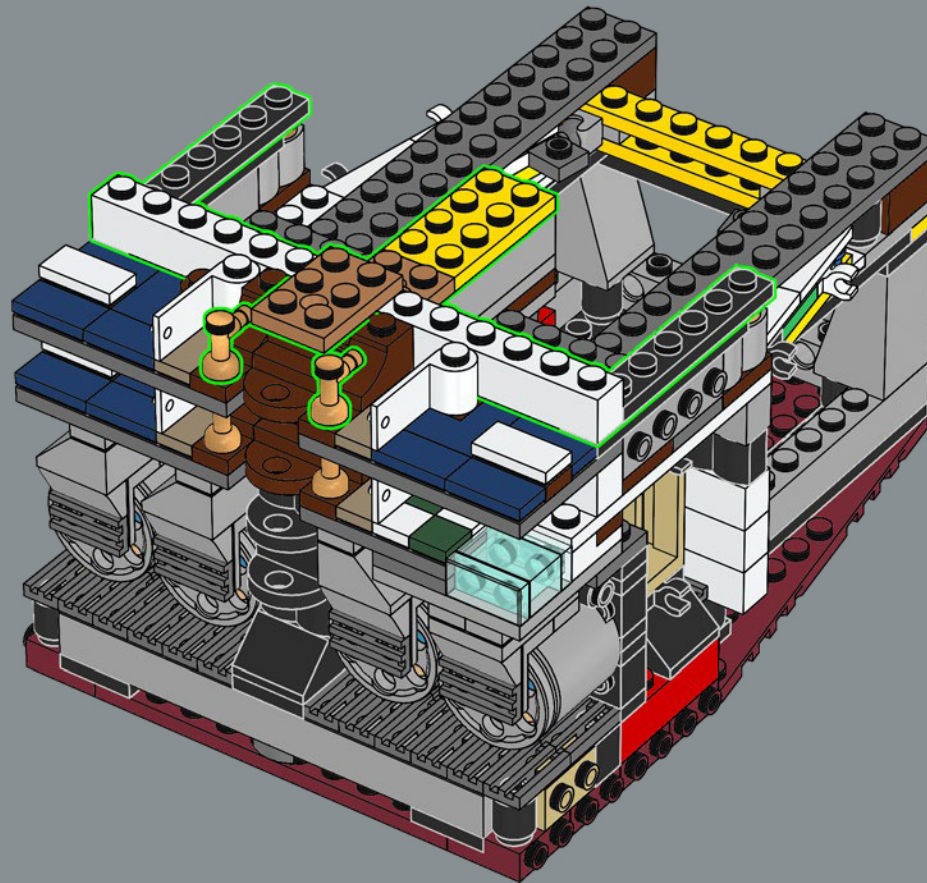

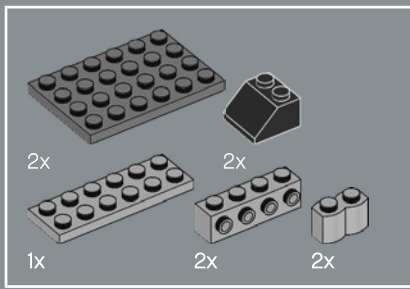

182

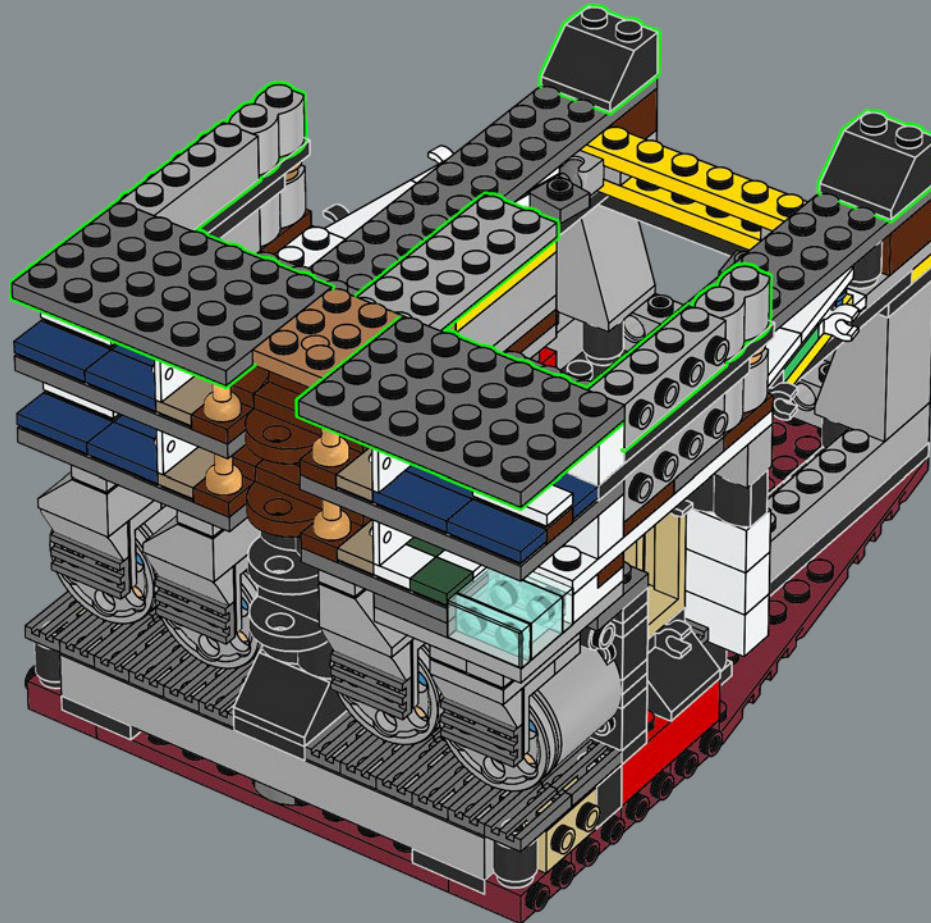

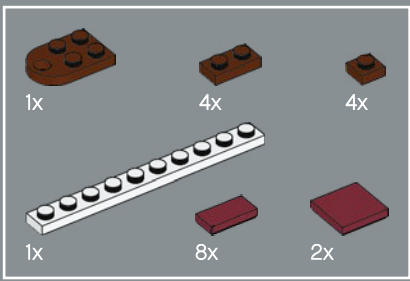

183

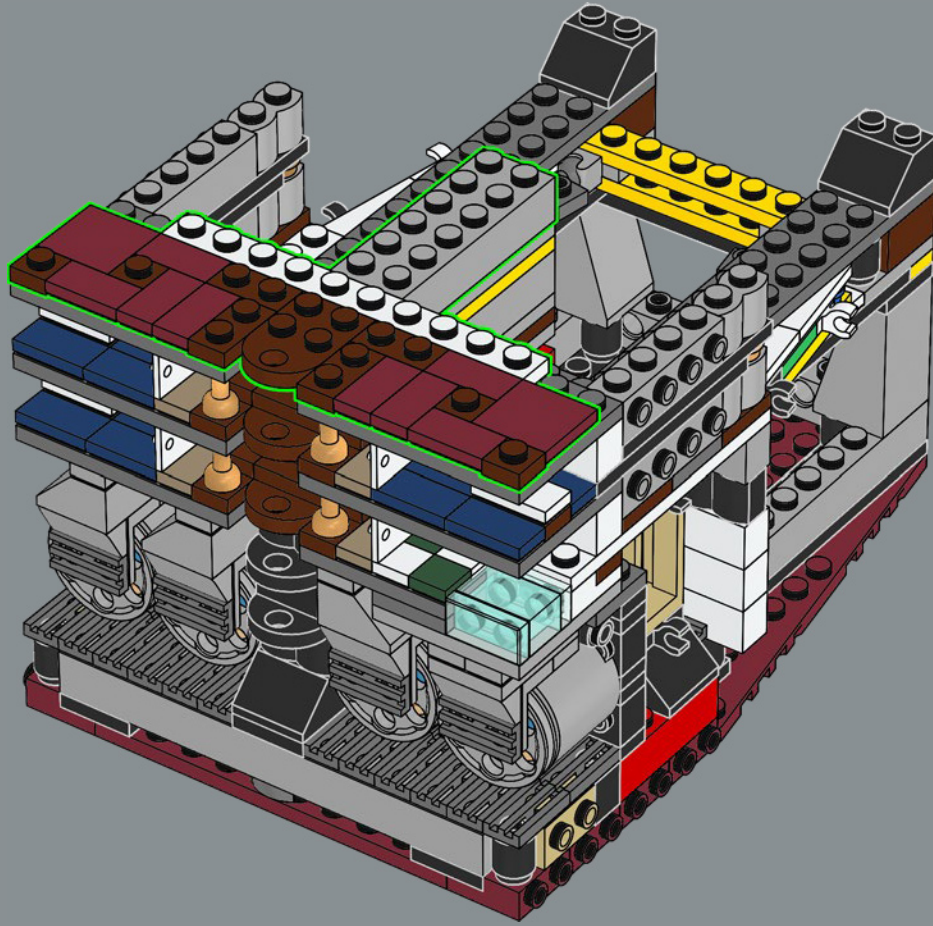



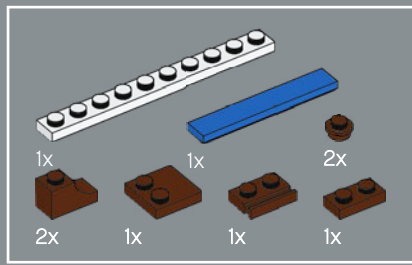

184

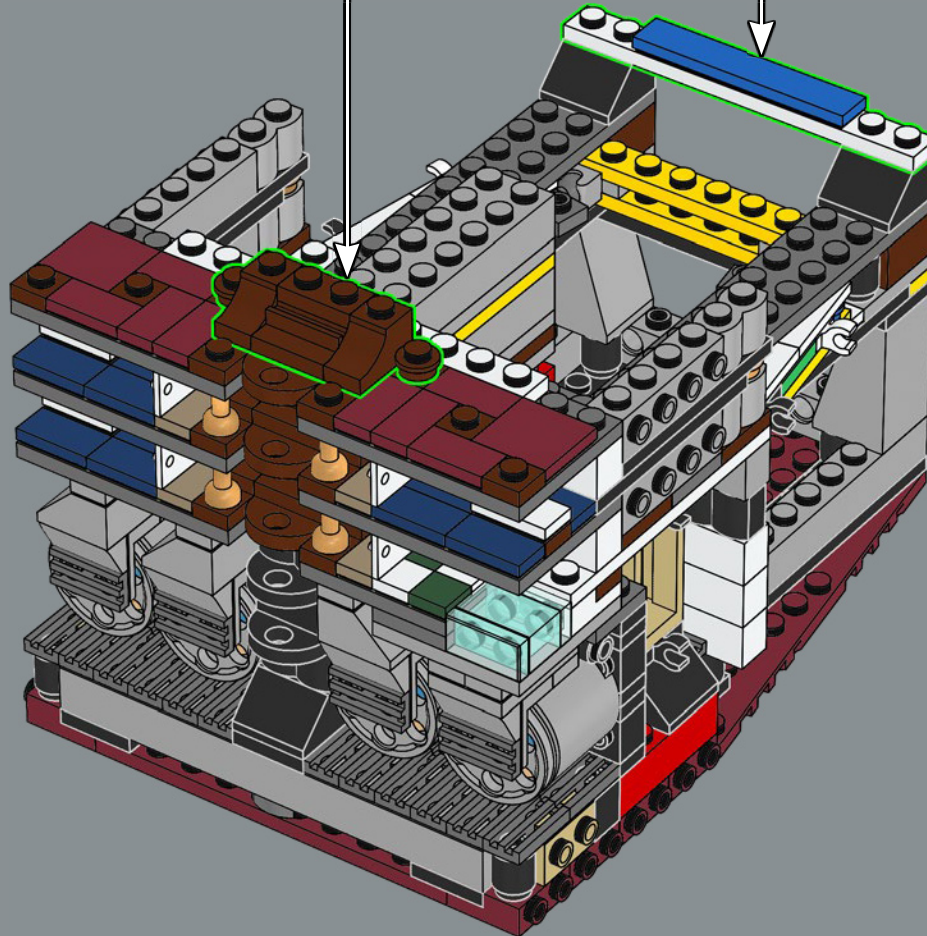
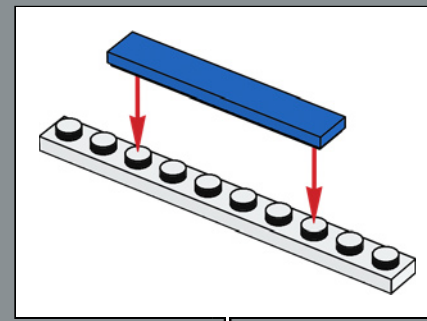
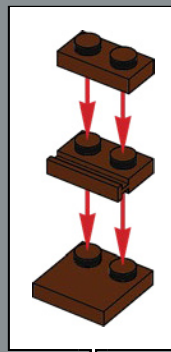

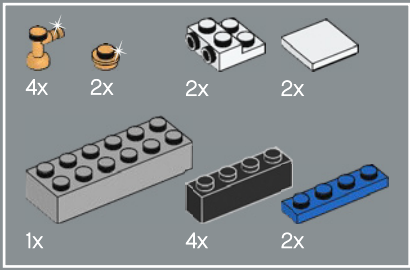

185

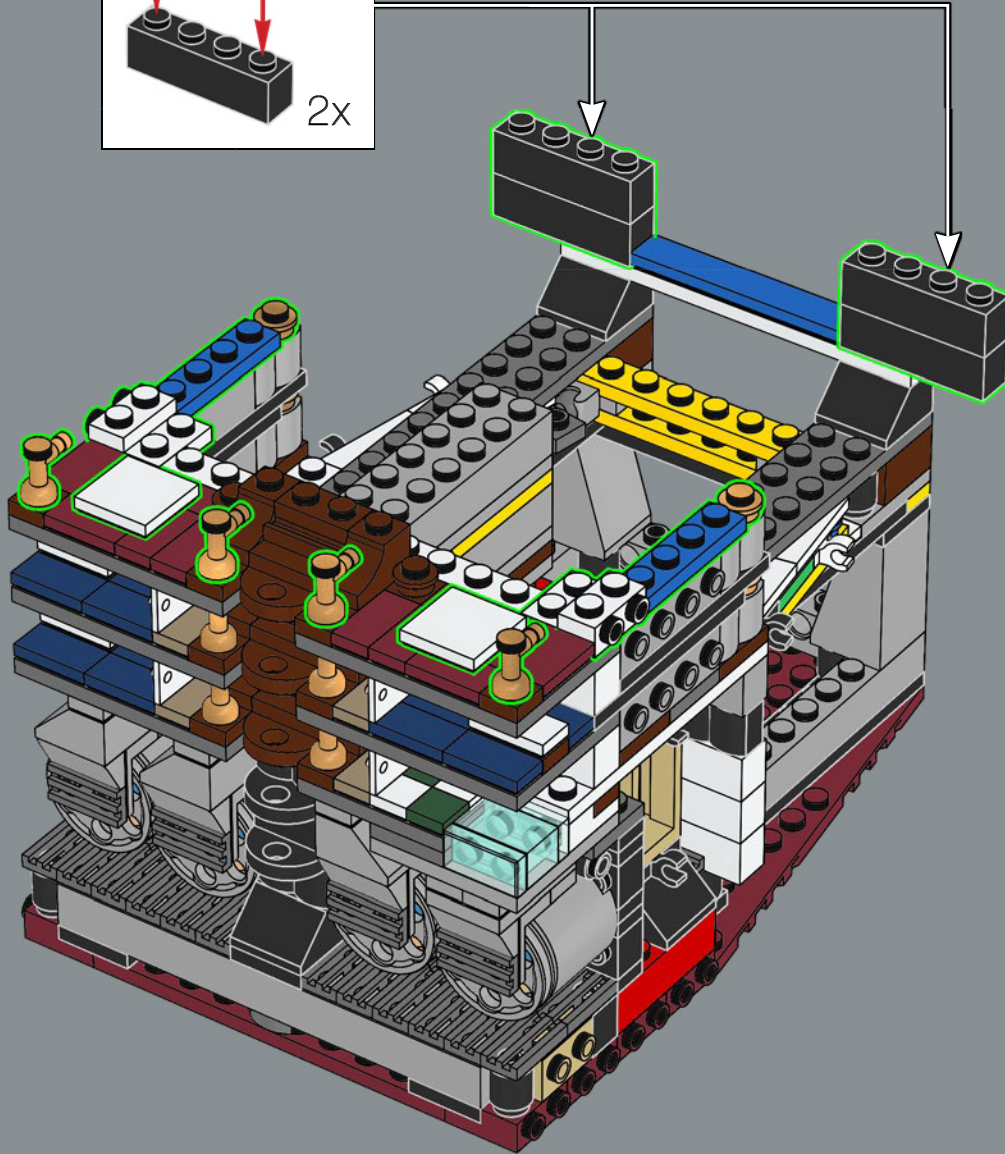
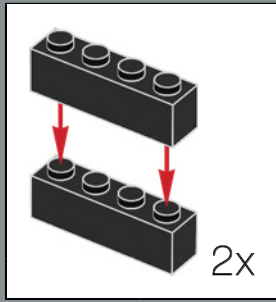

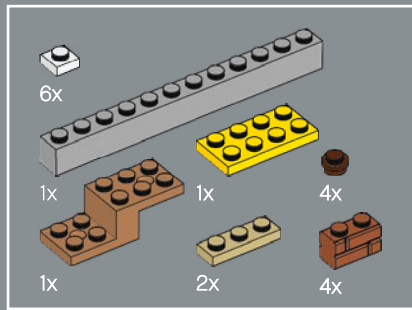

186

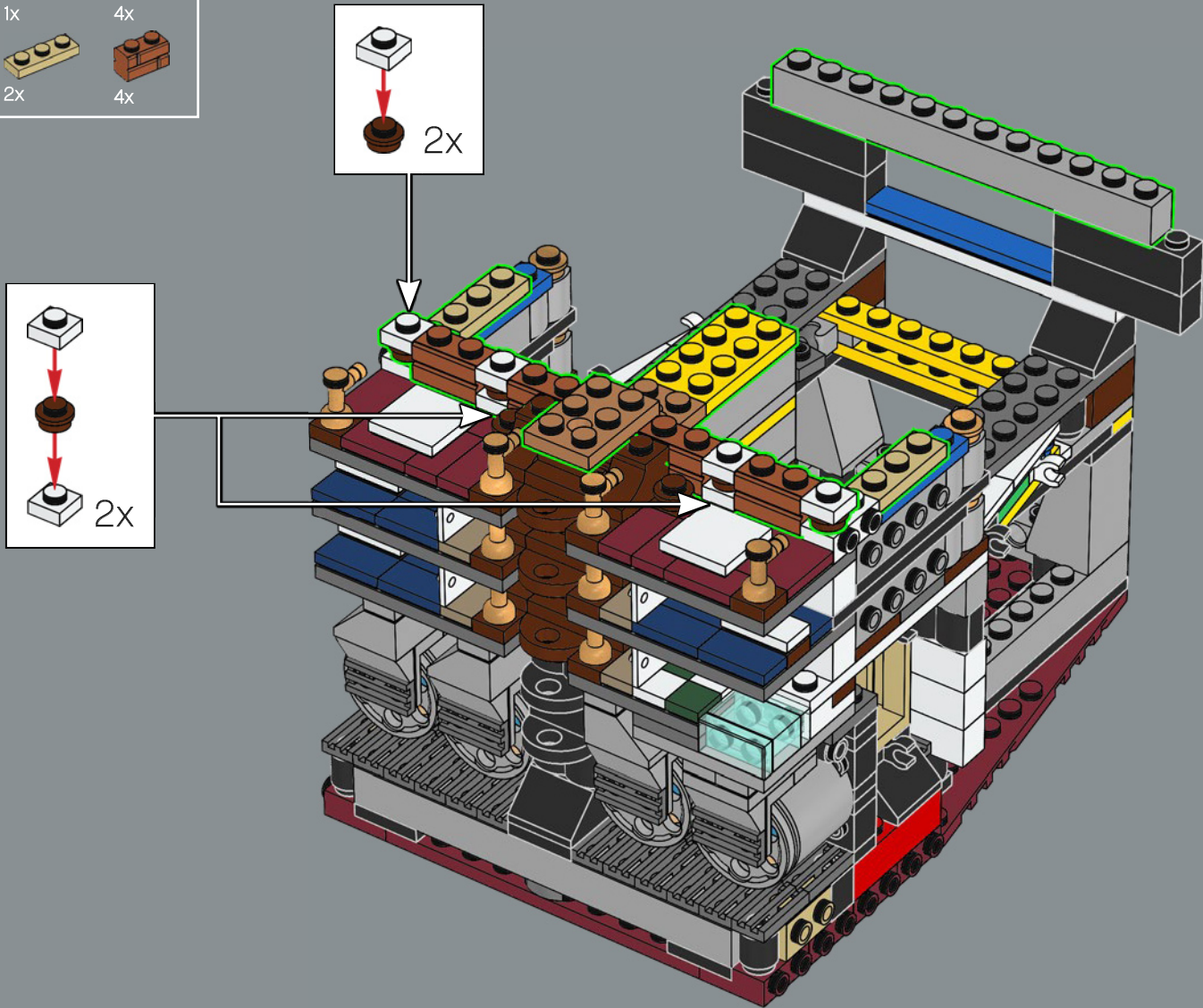

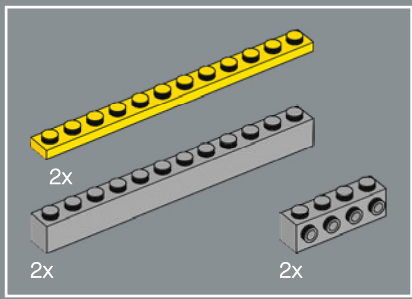

187

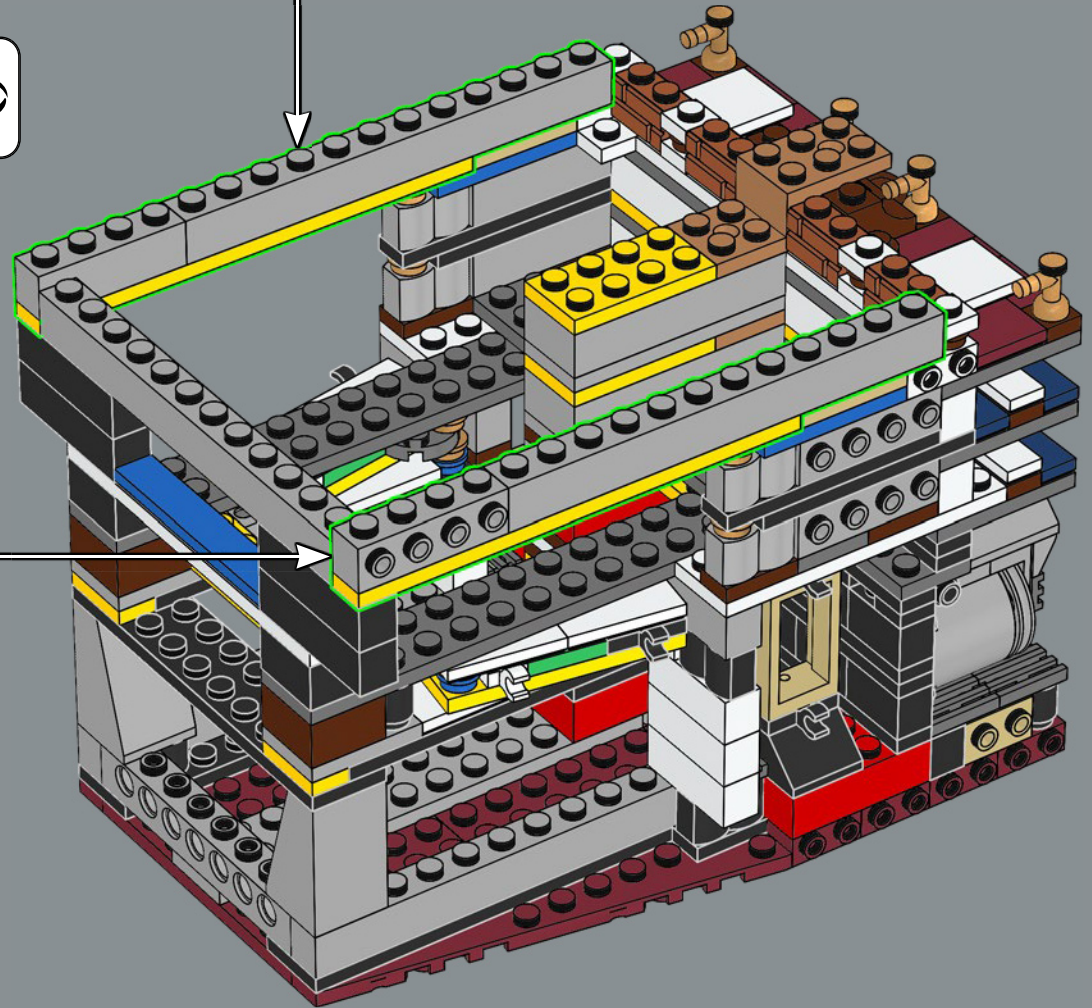
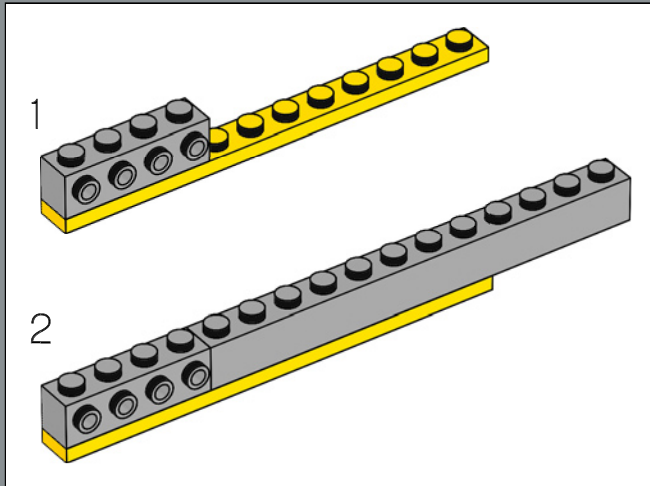
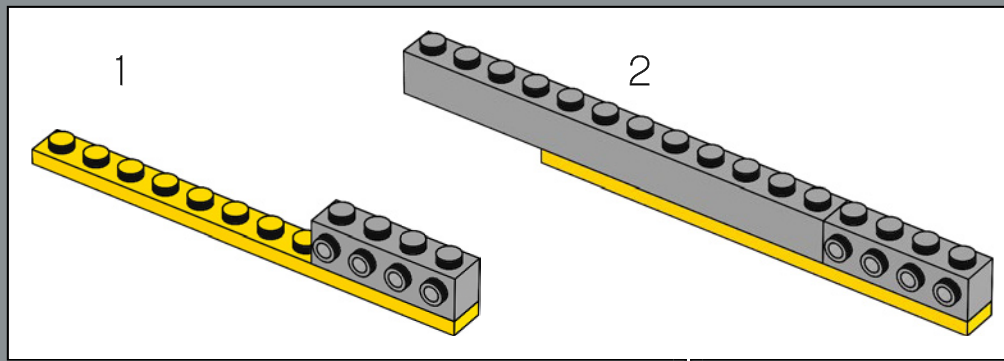

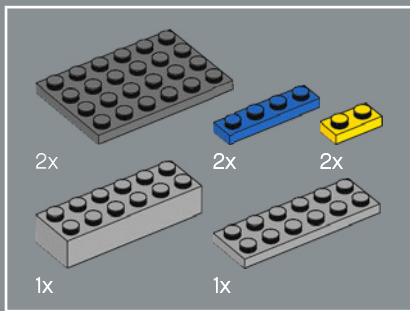

188

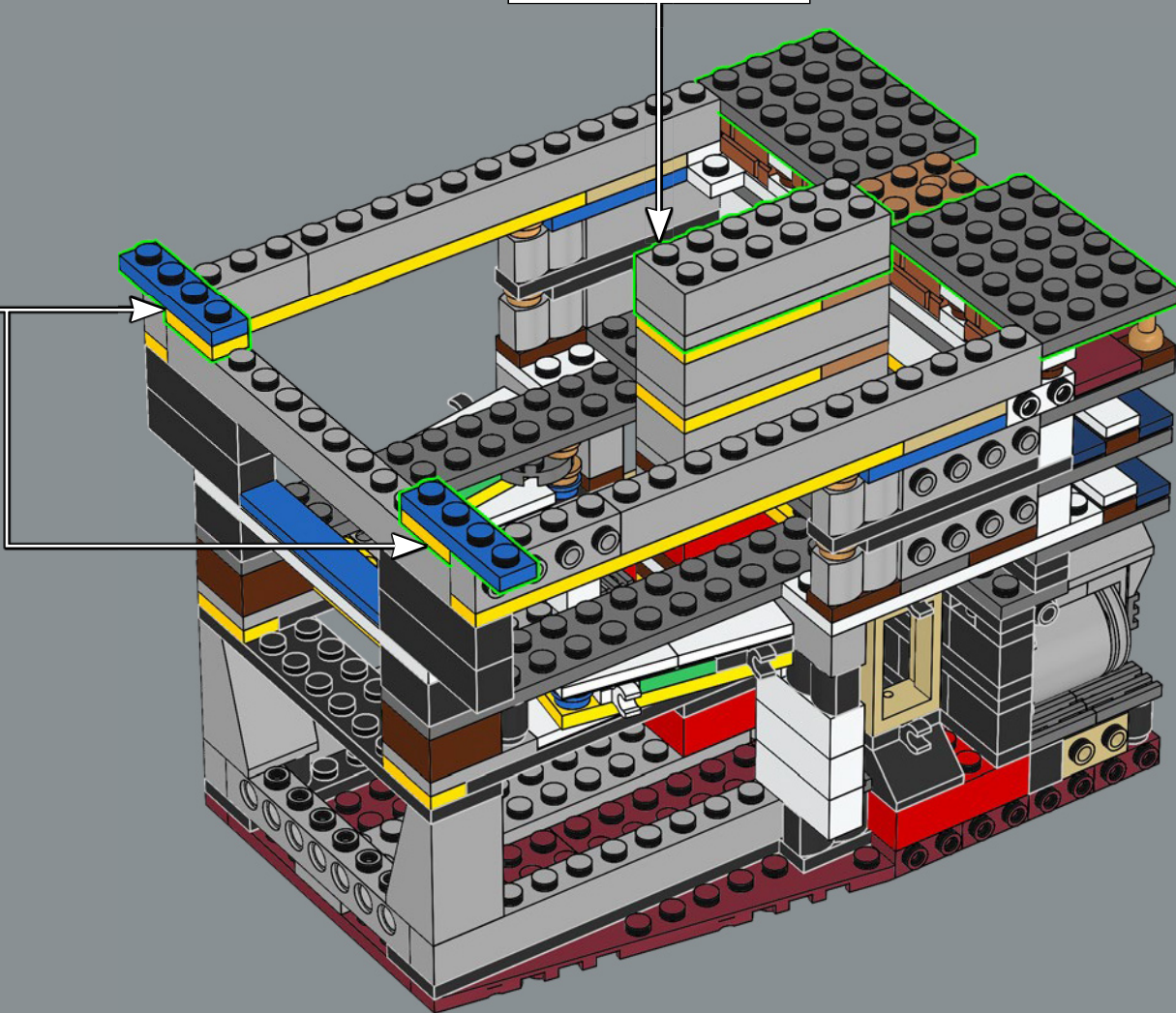
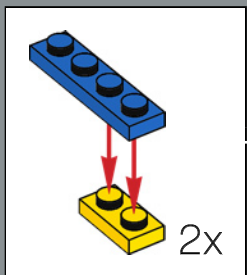
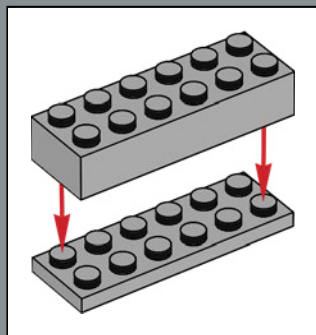

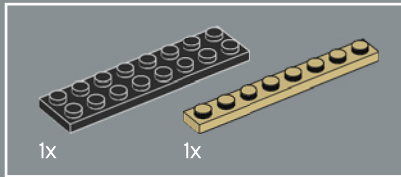
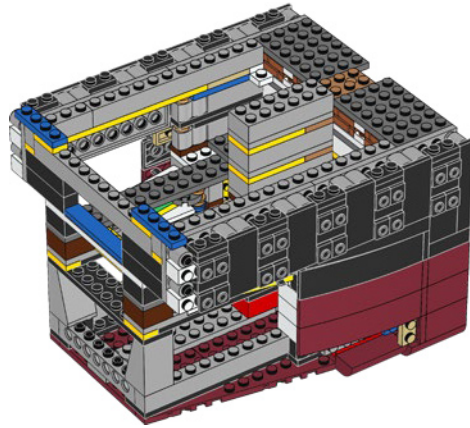
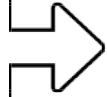

190

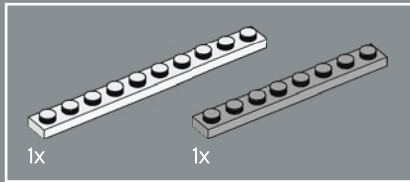
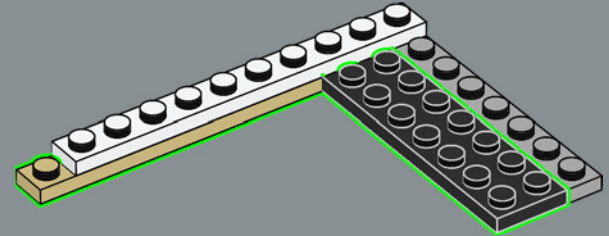

189

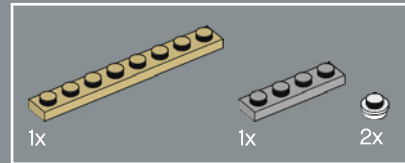
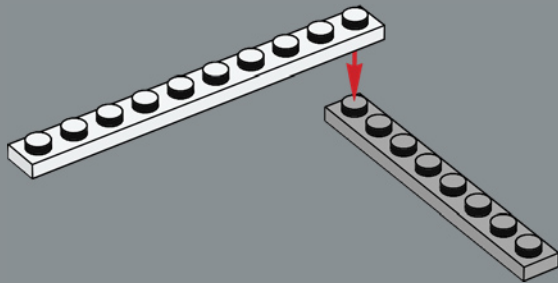

191

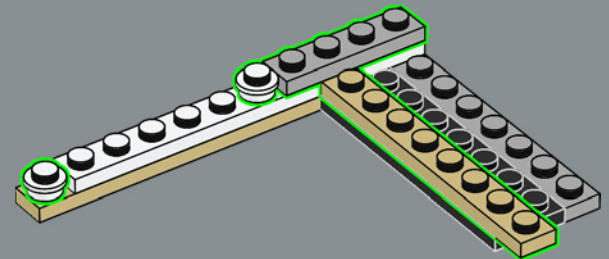

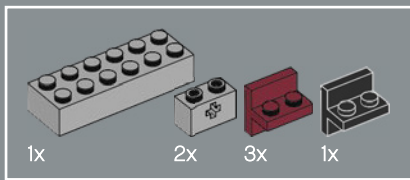

192

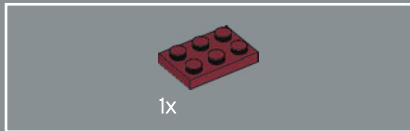
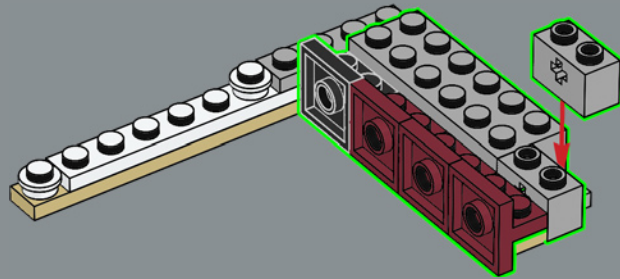

193

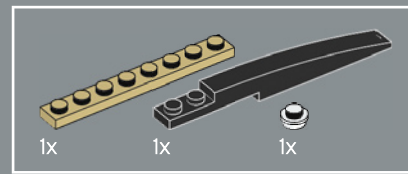
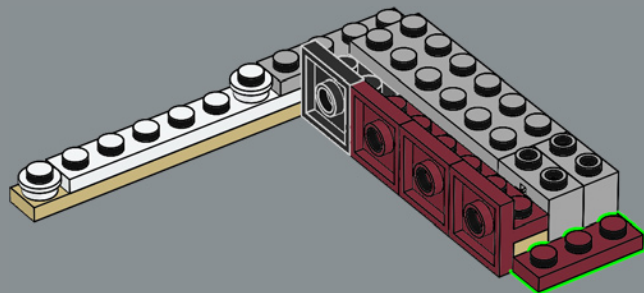

194

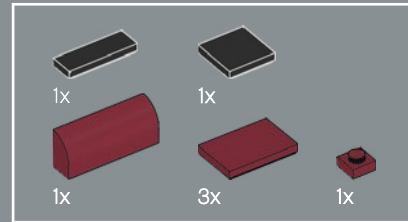
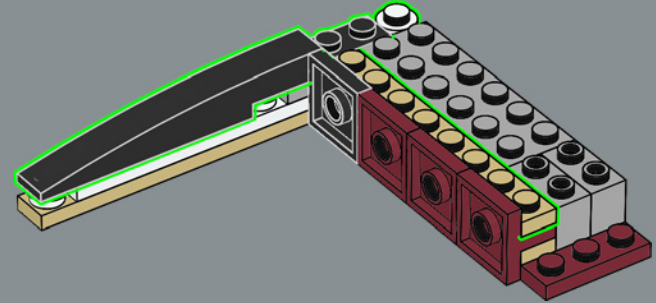

195

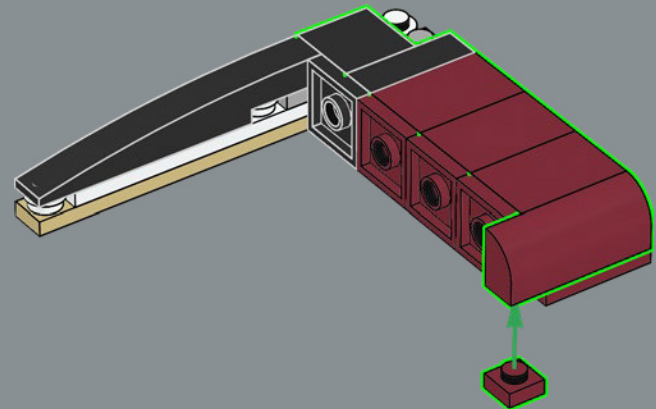

196

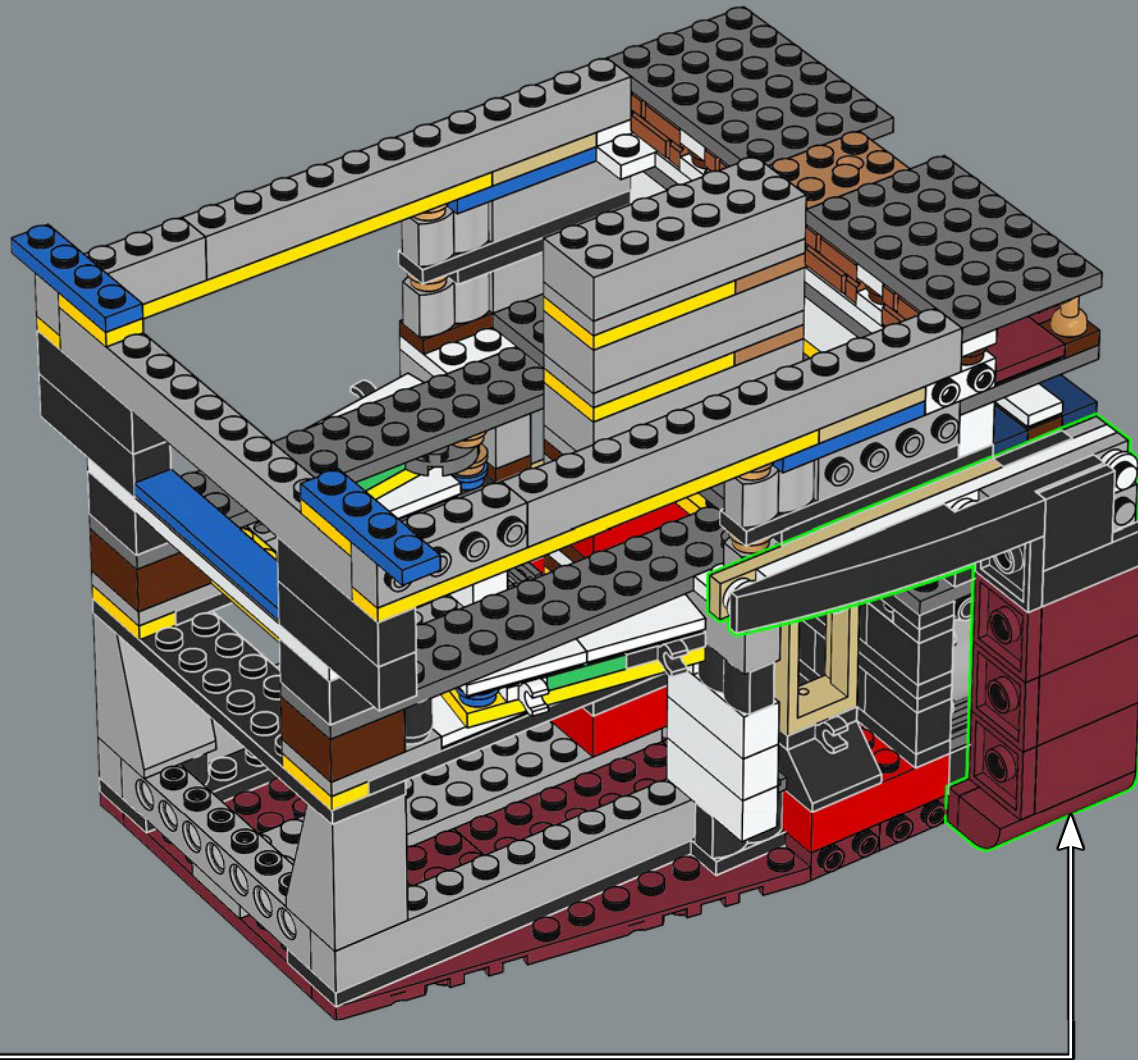



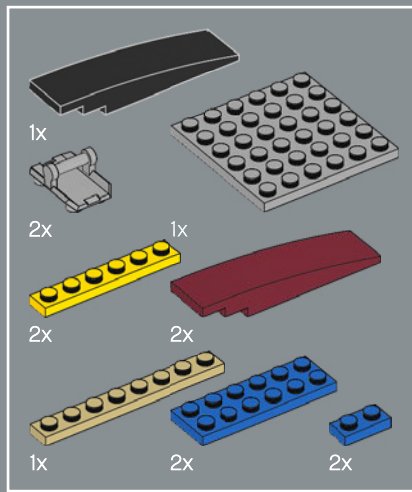

197

1

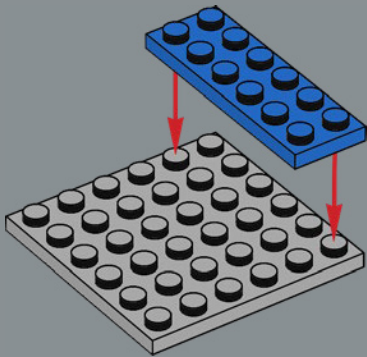

2

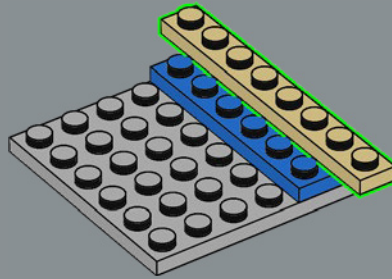

3

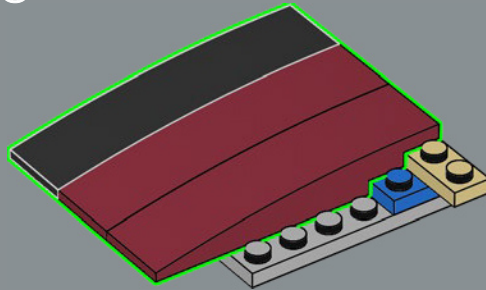

4

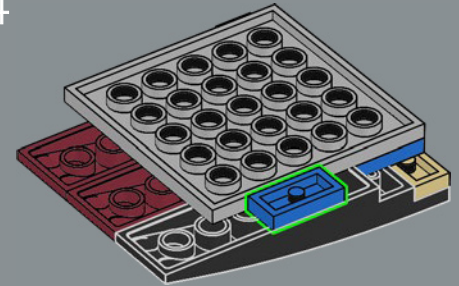

5

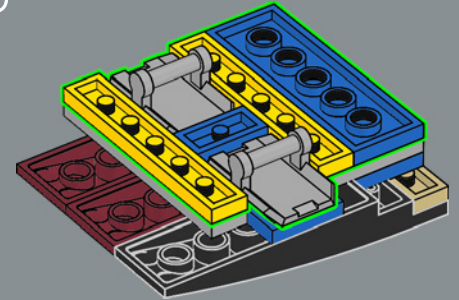

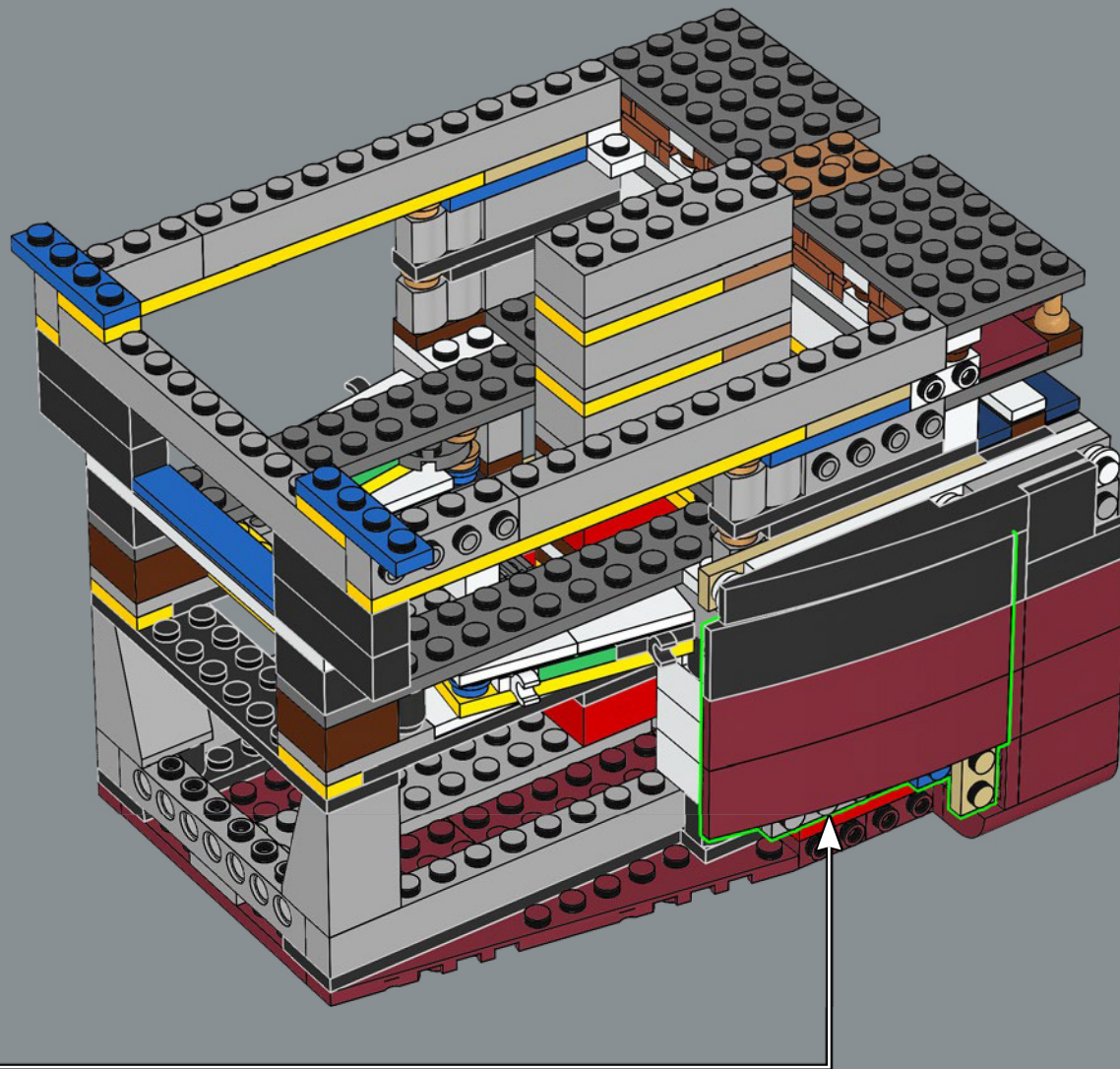

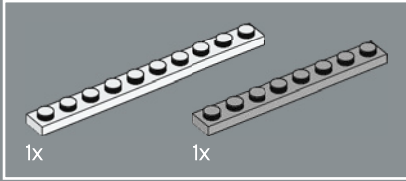
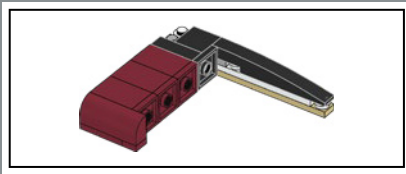

198

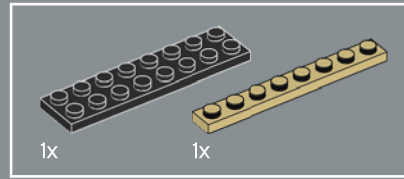
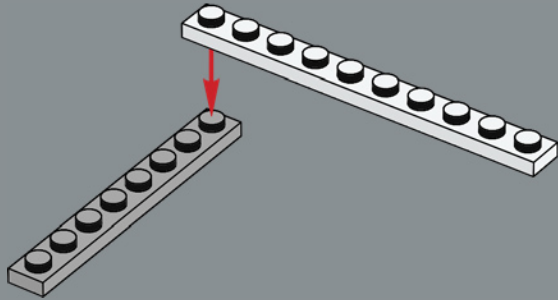

199

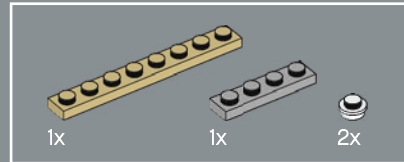
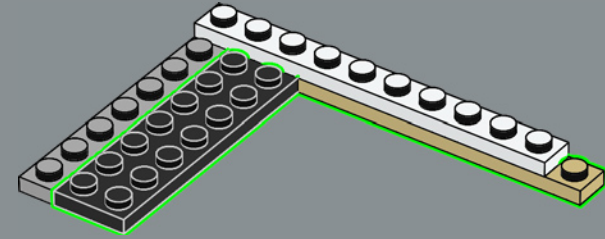

200

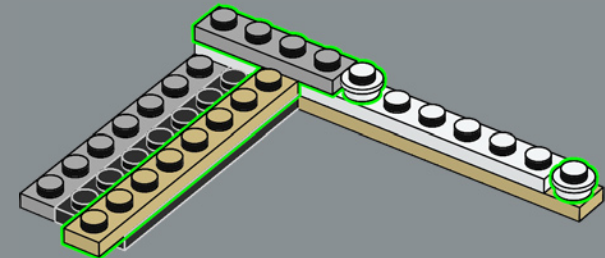

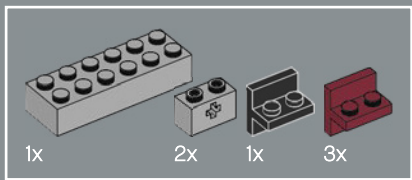

201

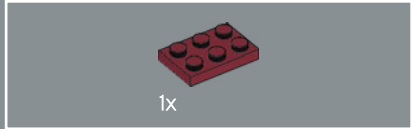
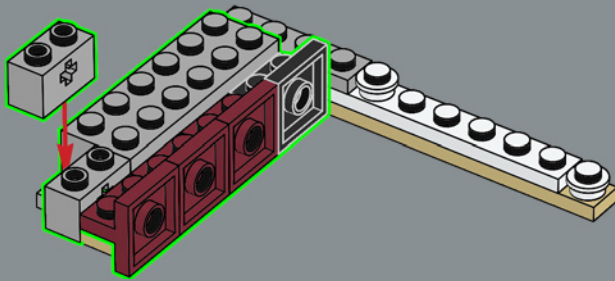

202

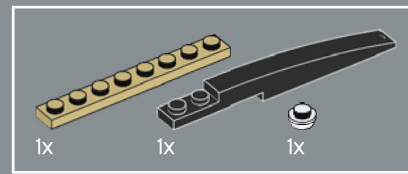
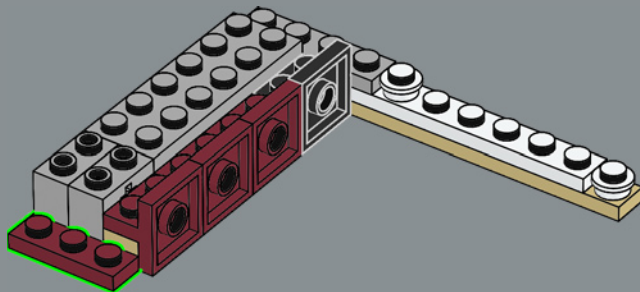

203

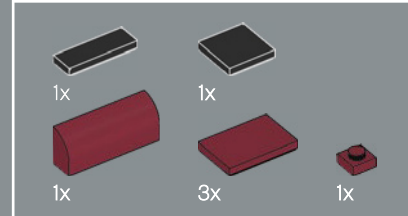
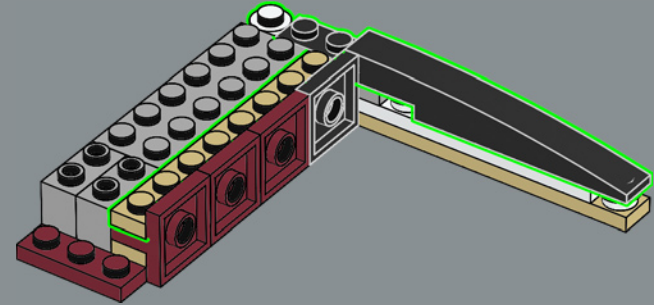

204

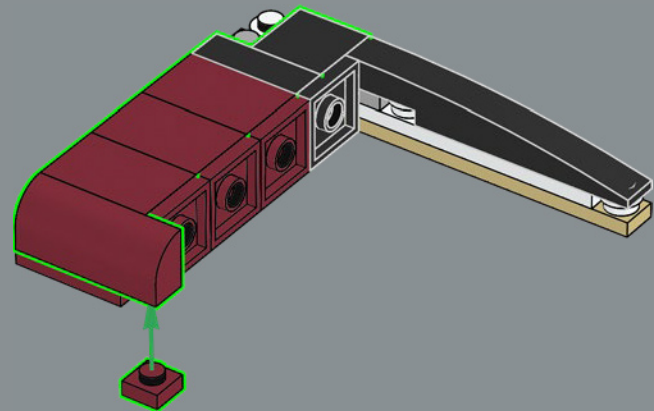

205

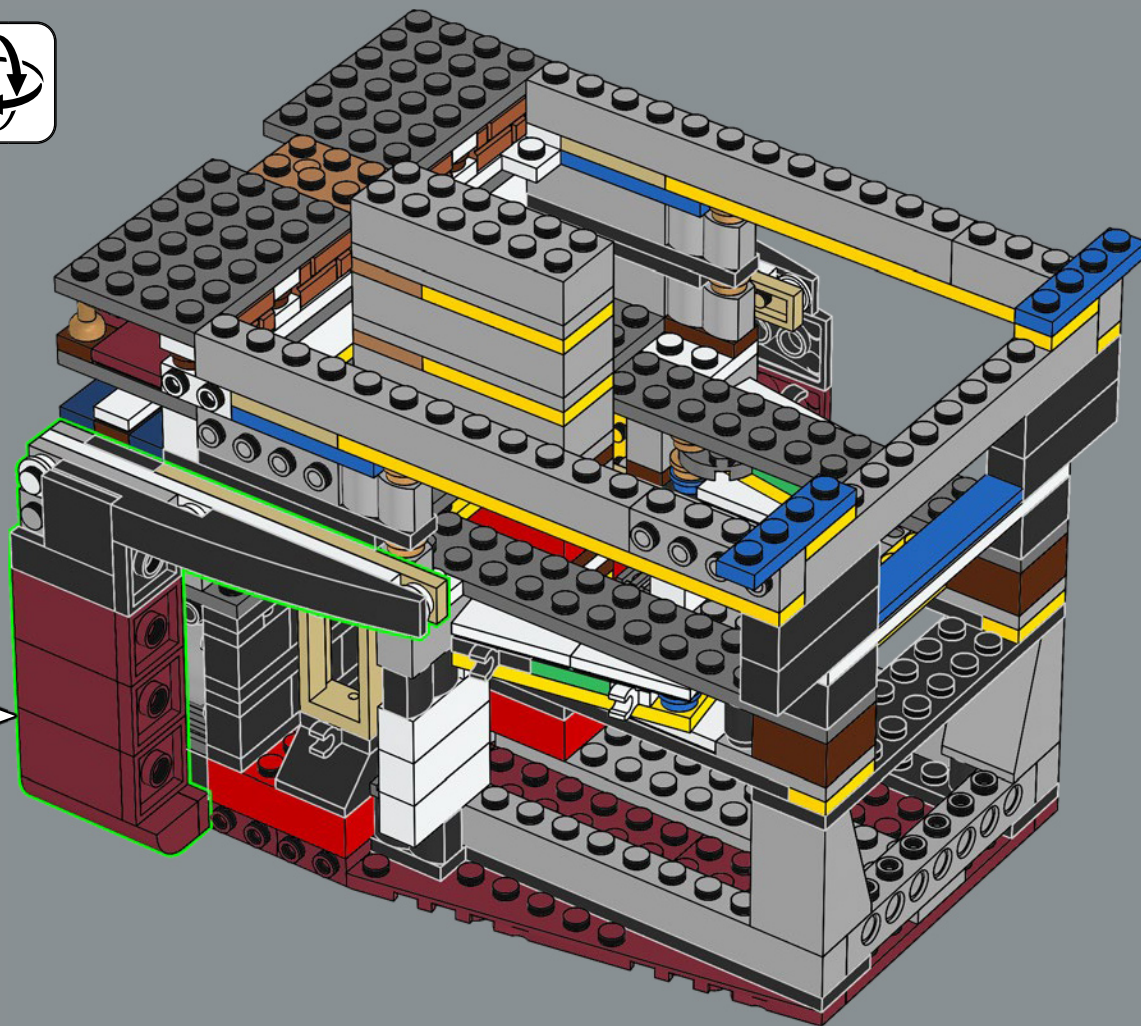

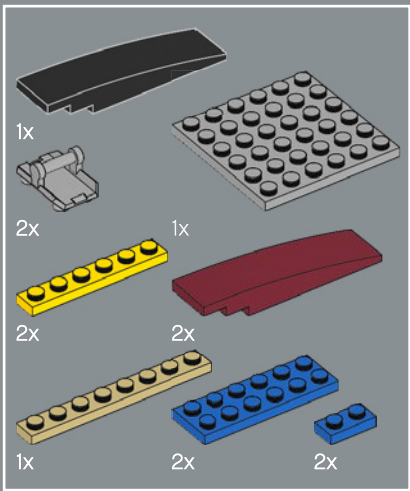

206

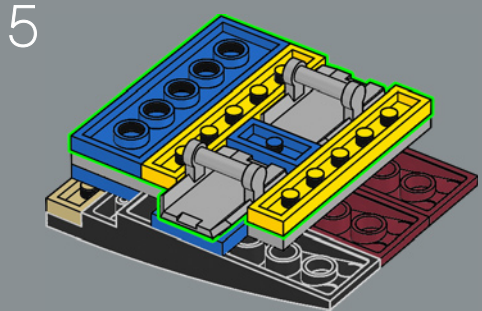
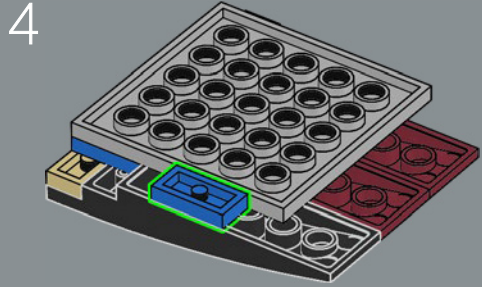
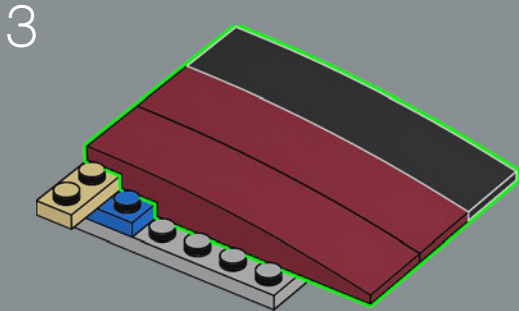
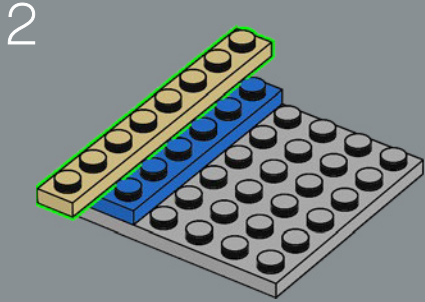
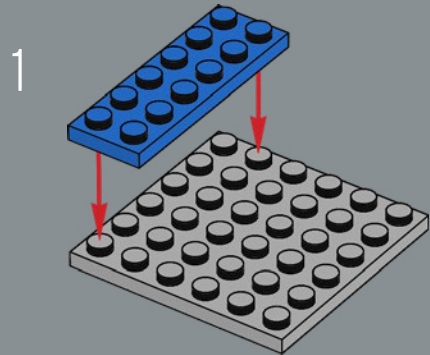

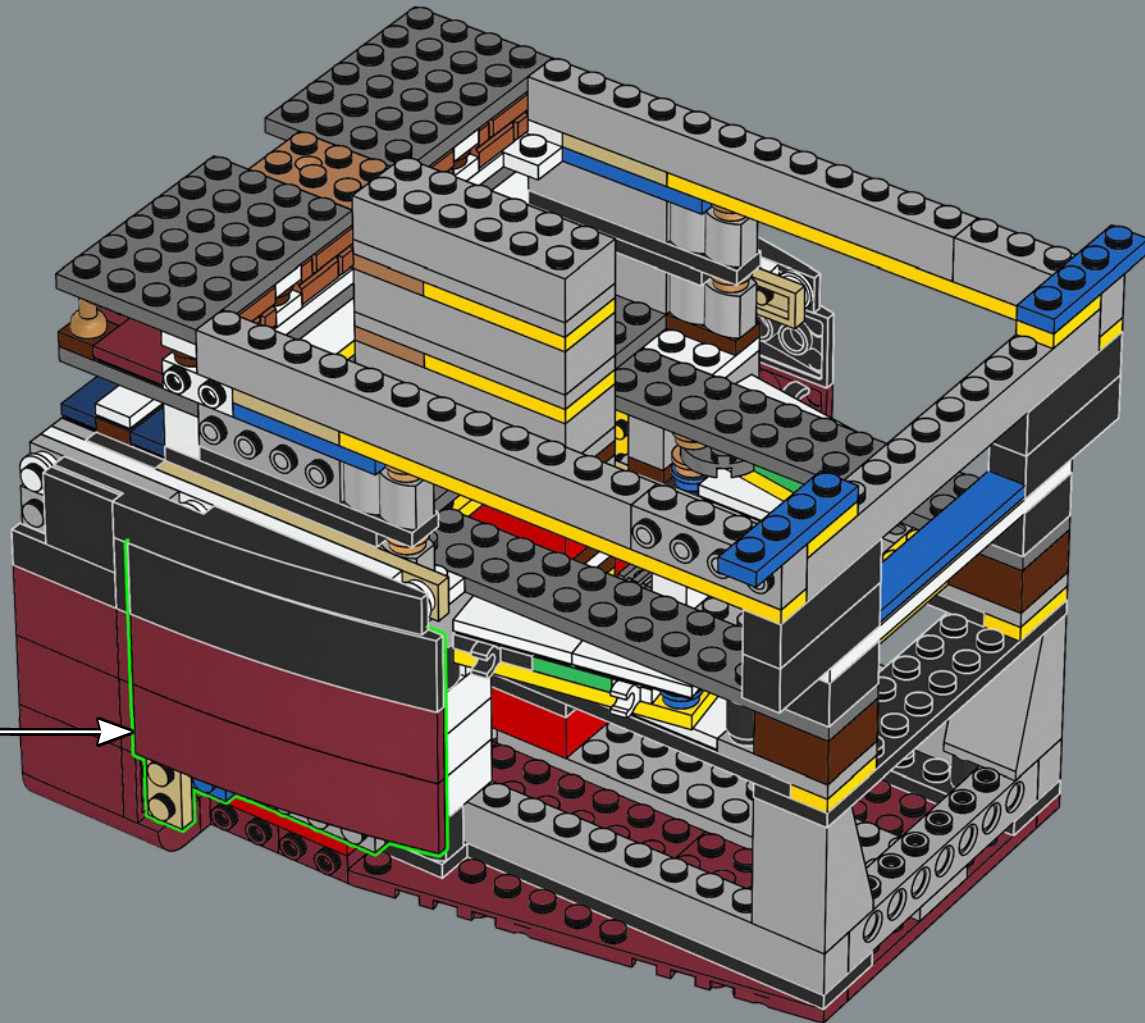

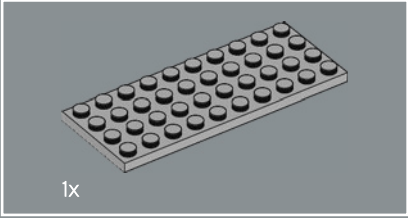
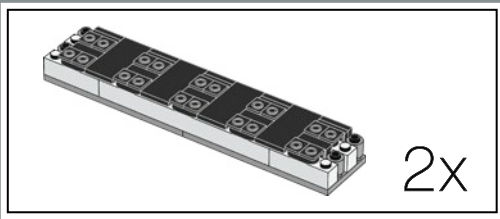

207

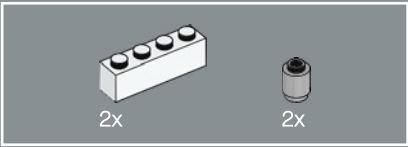
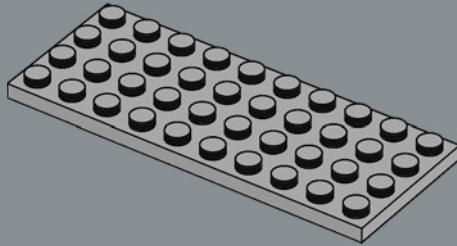

208

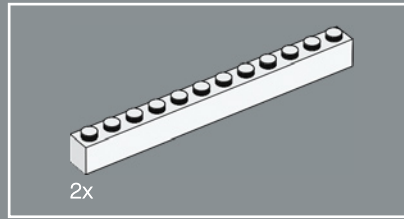
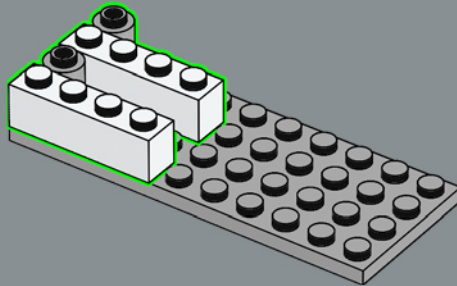

209

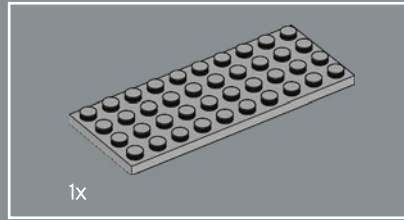
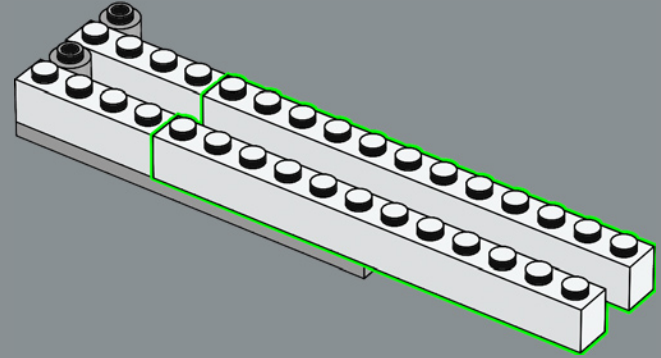

210

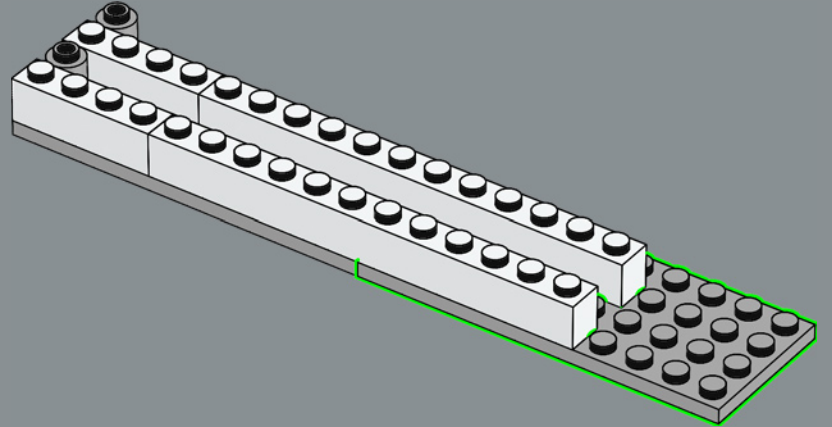



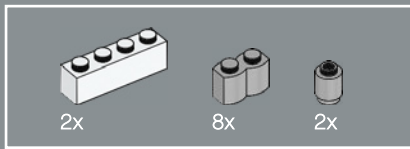

211

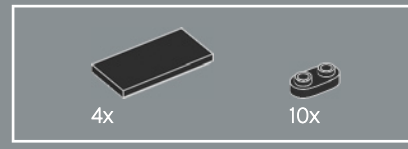
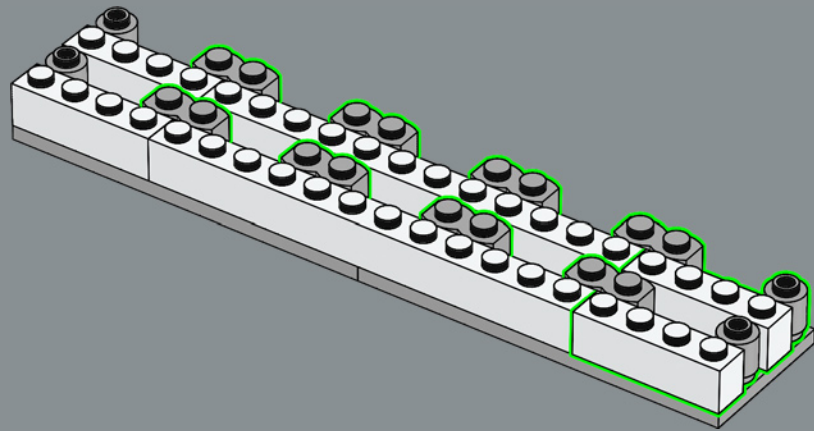

212

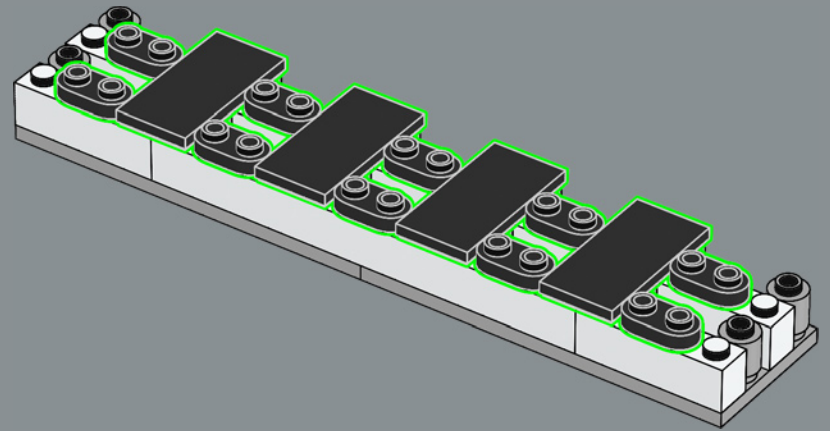

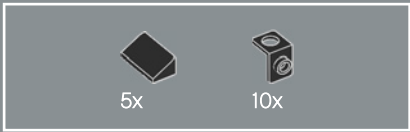

213

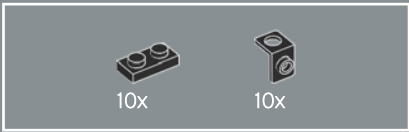
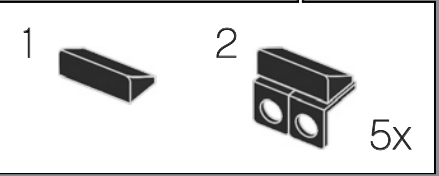
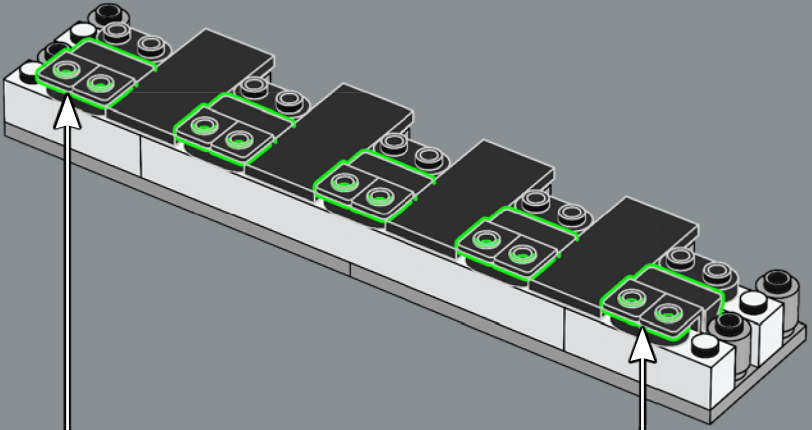

214

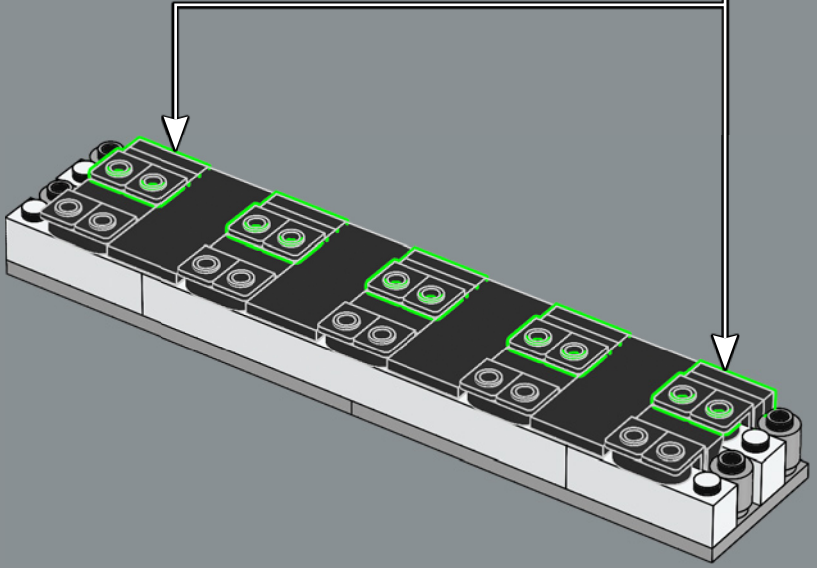
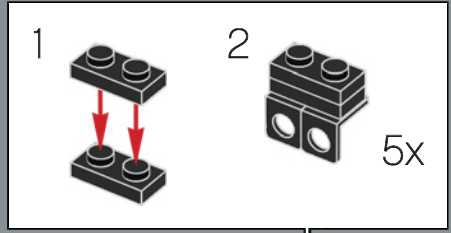

2x

215

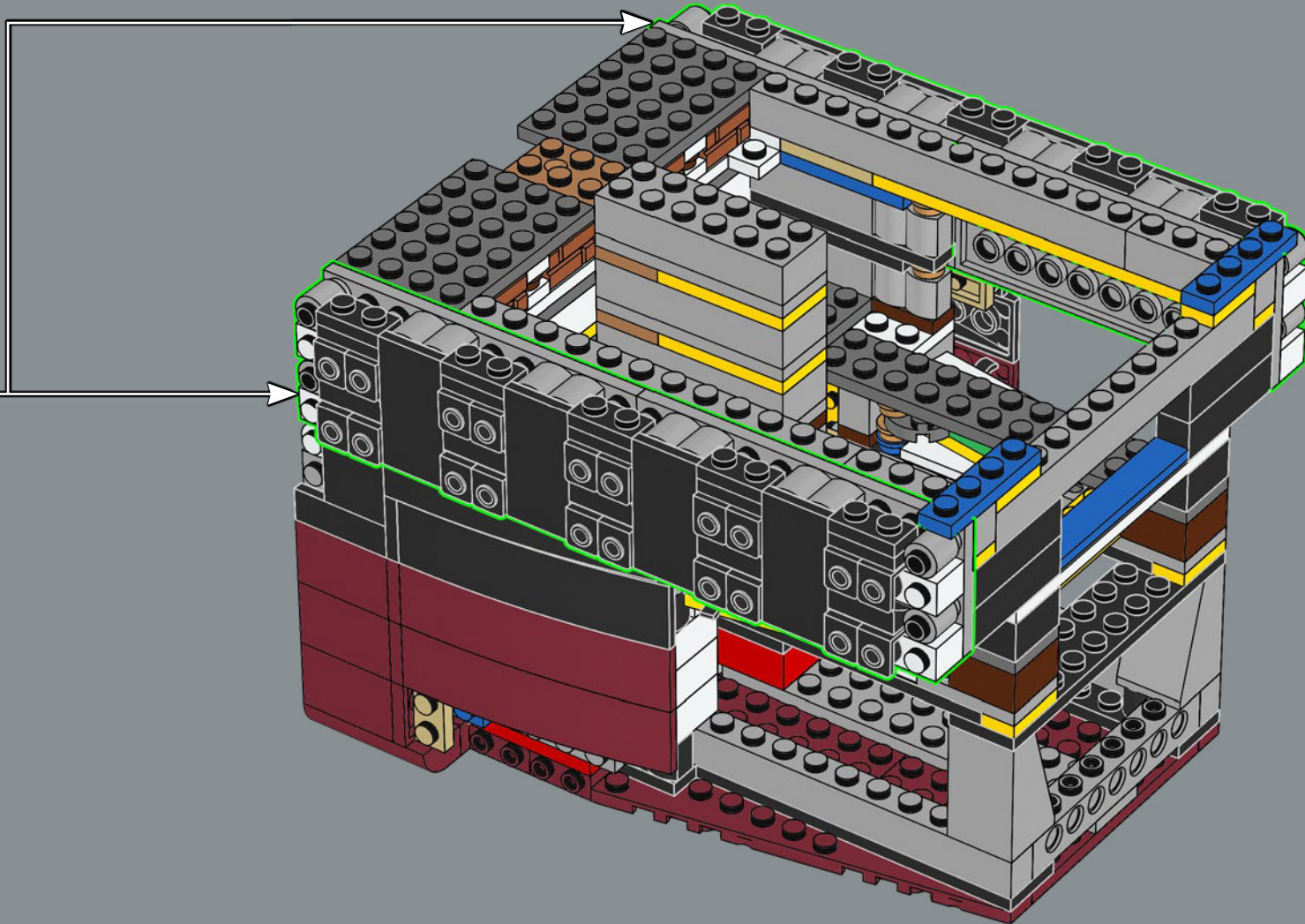

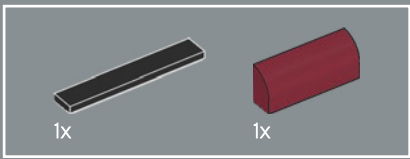

216

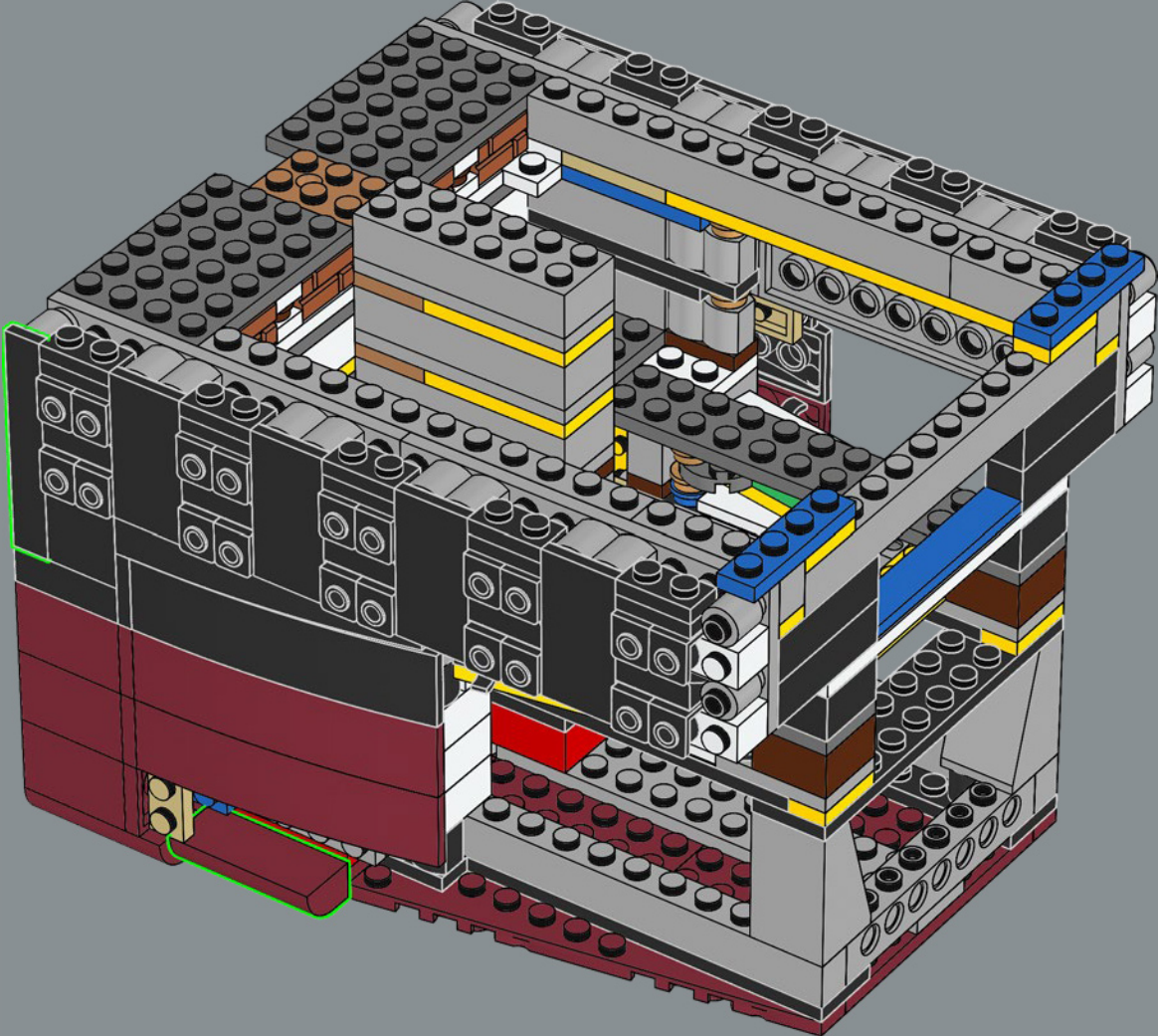

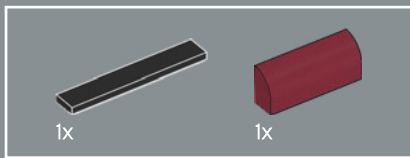

217

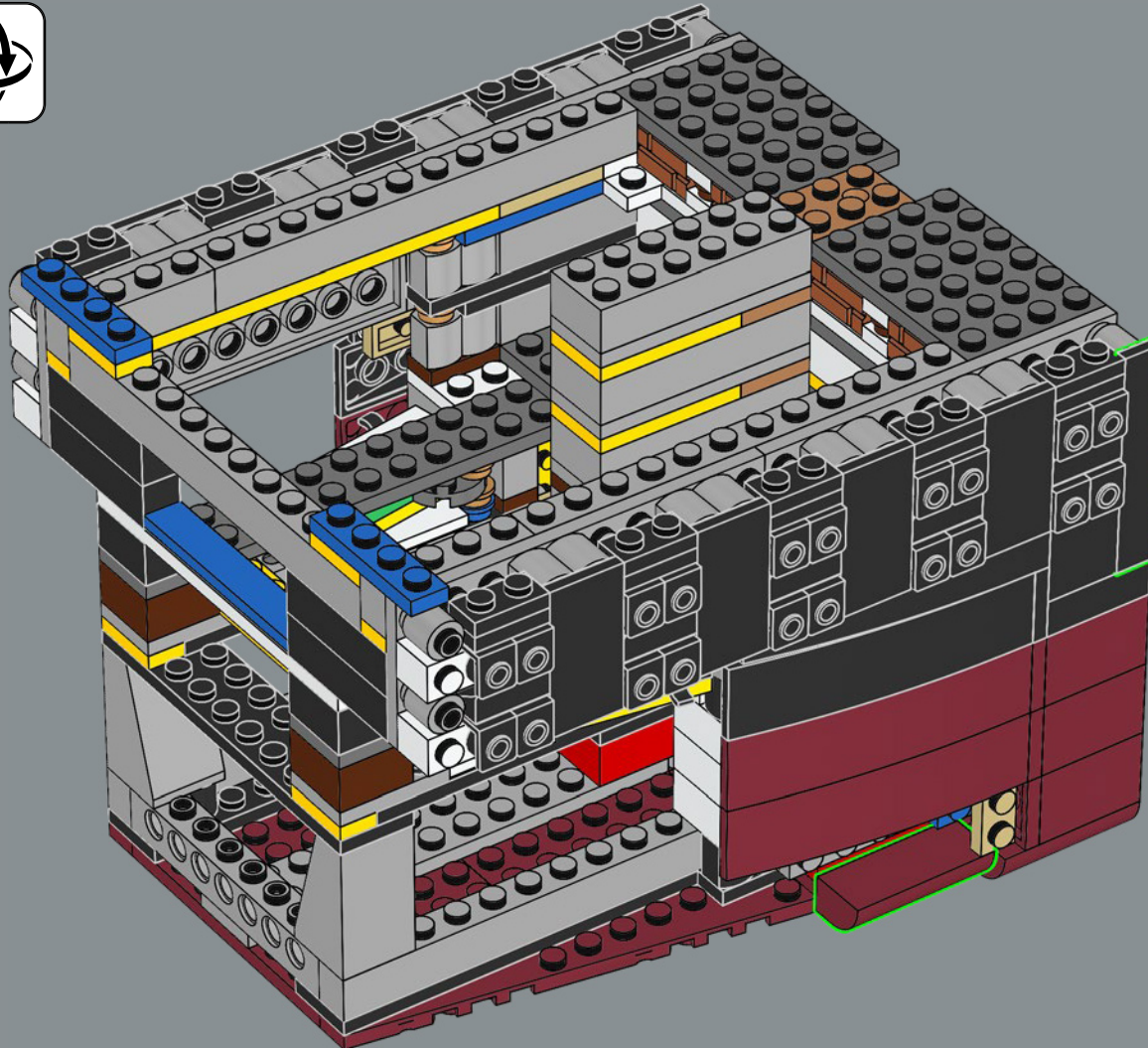

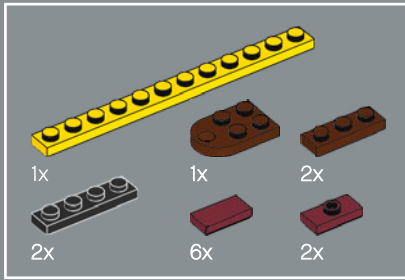
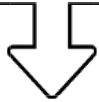

218

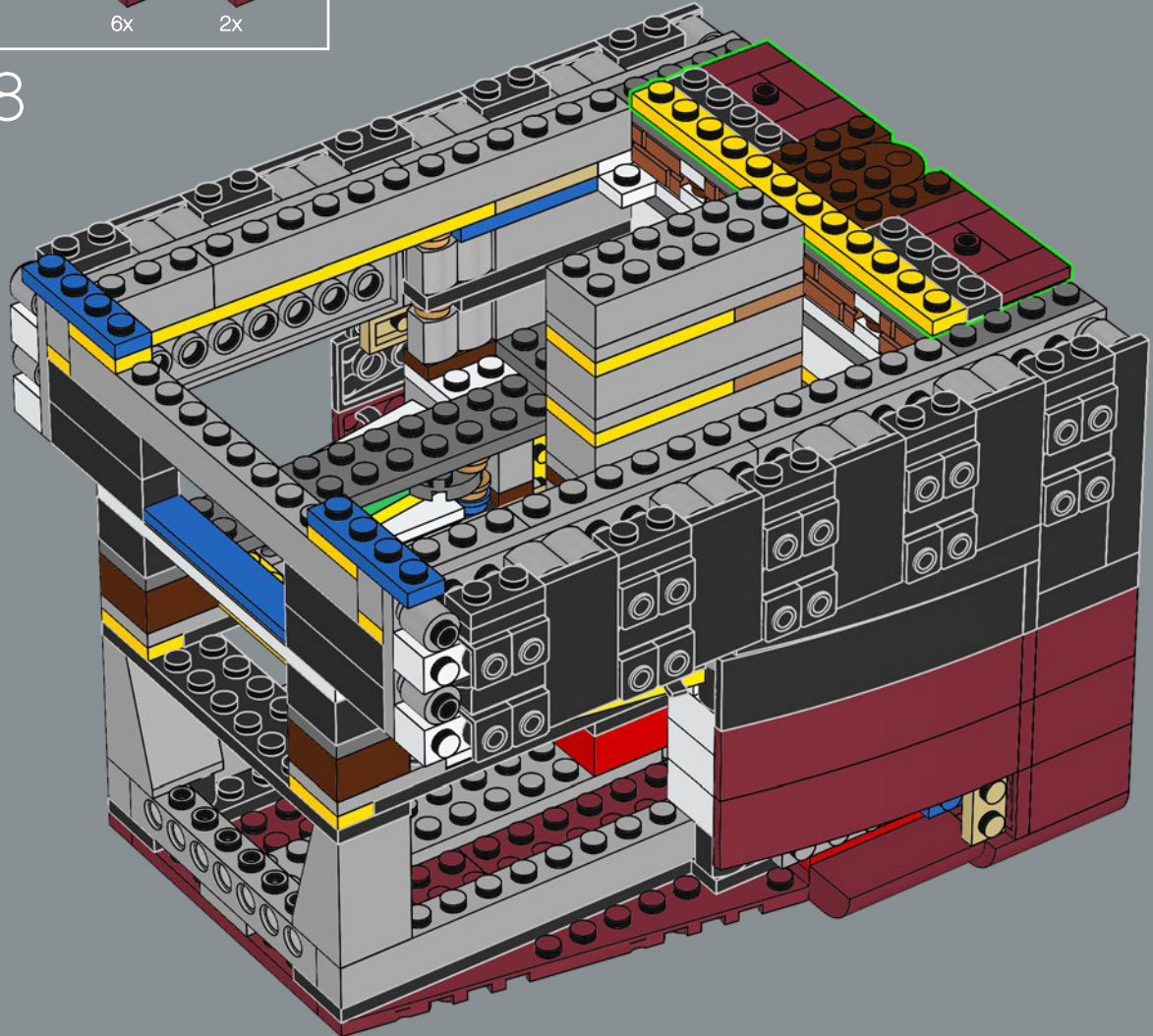



219

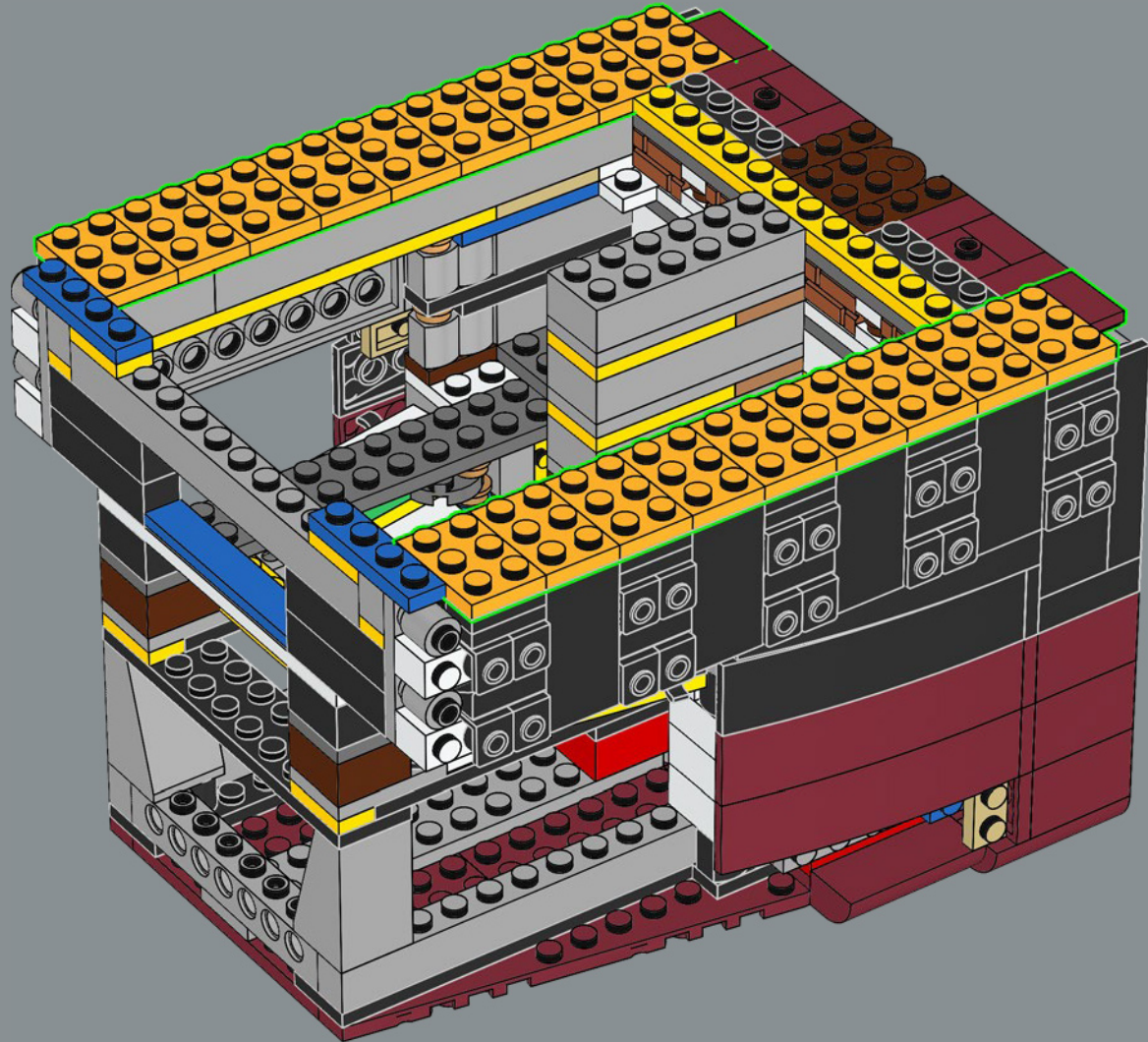

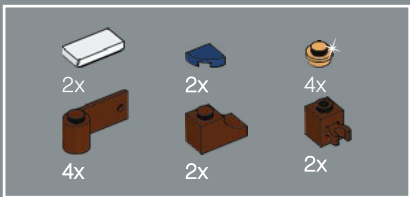

220

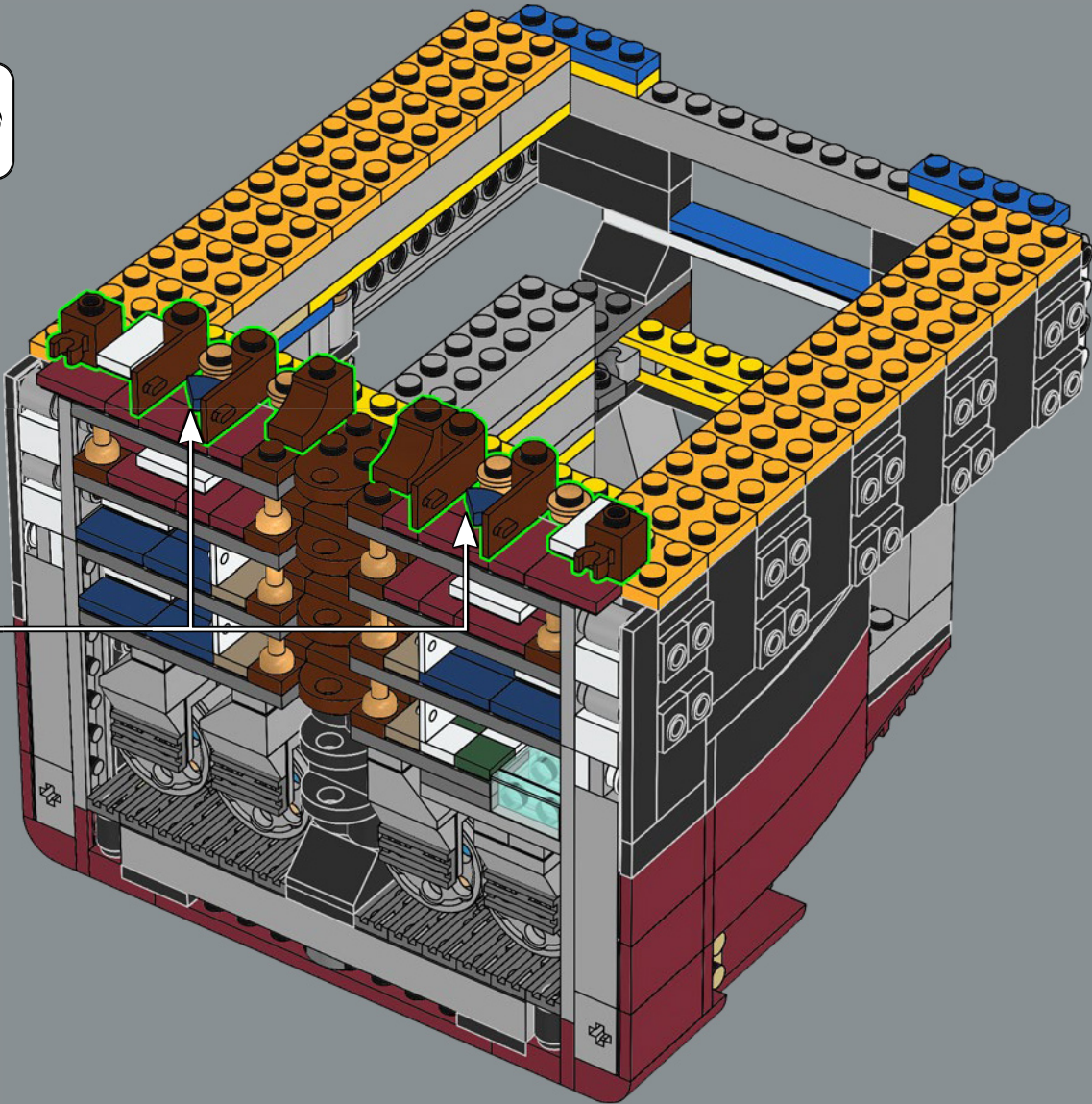





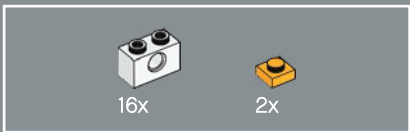

222

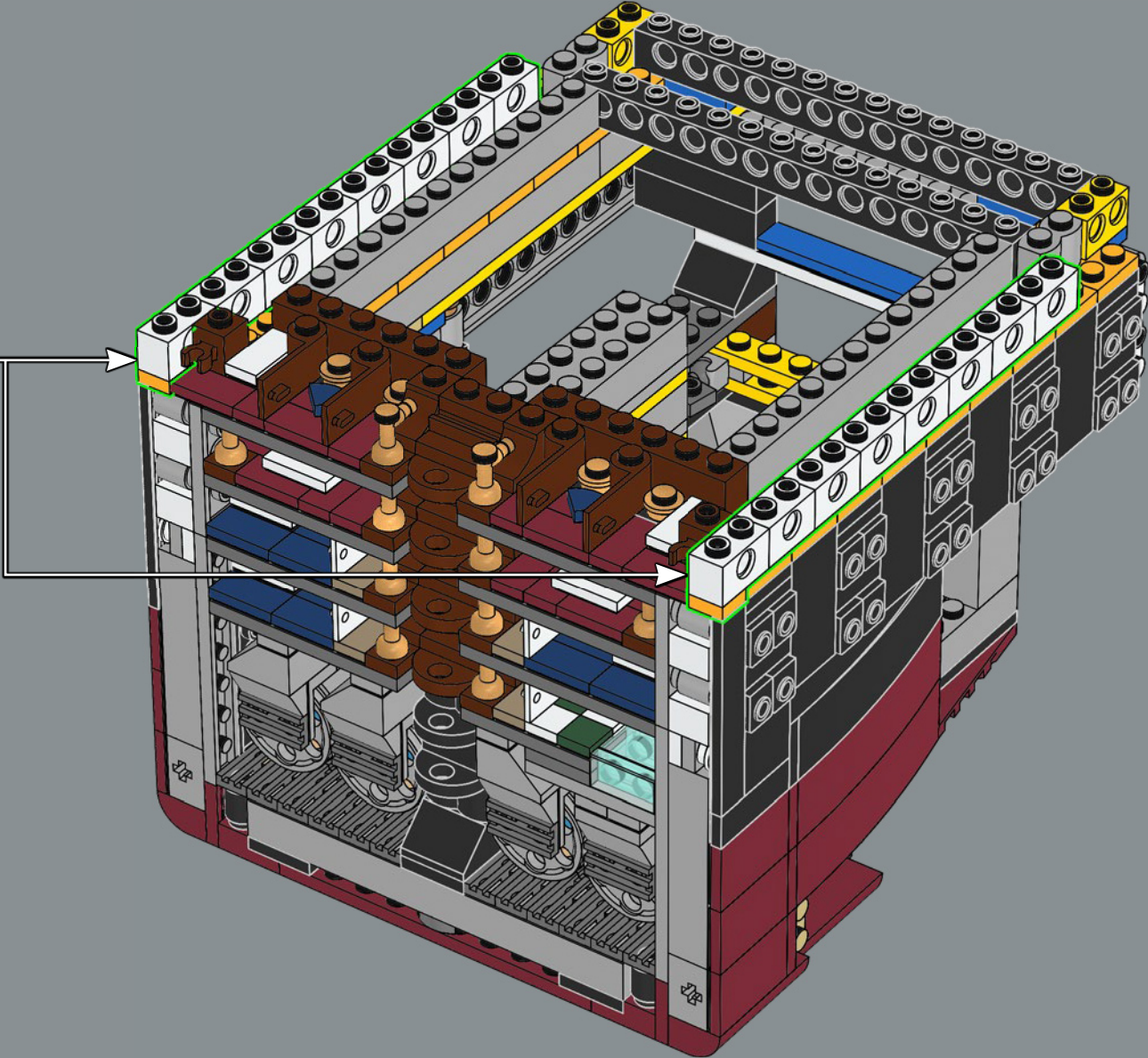
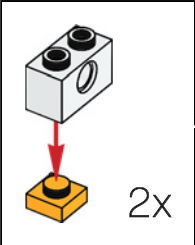

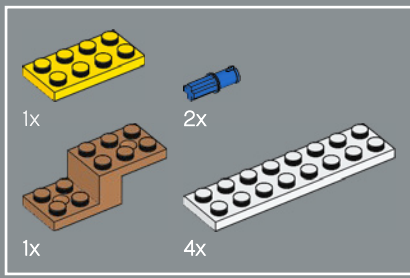

223

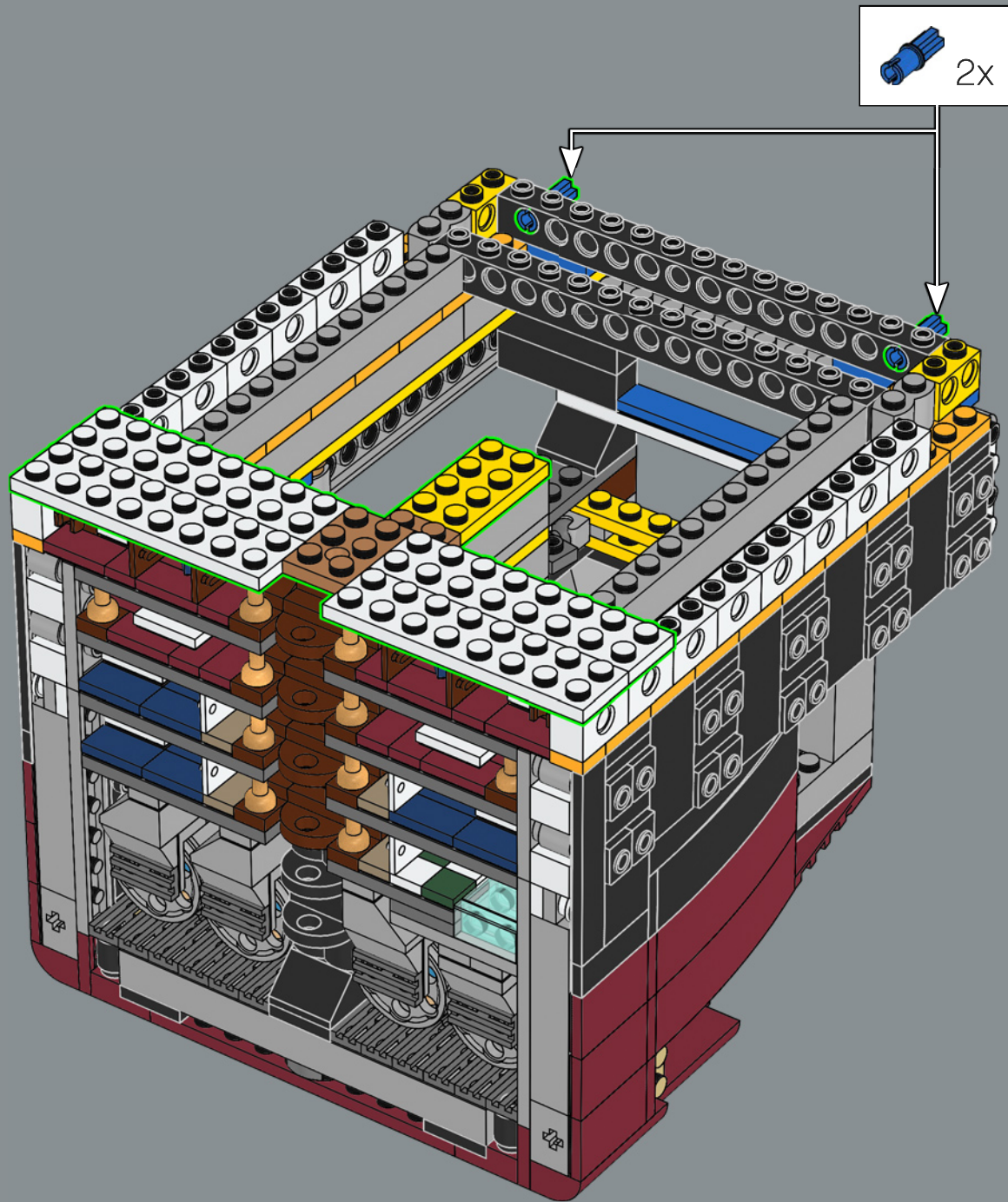

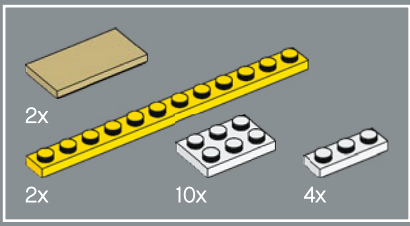

224

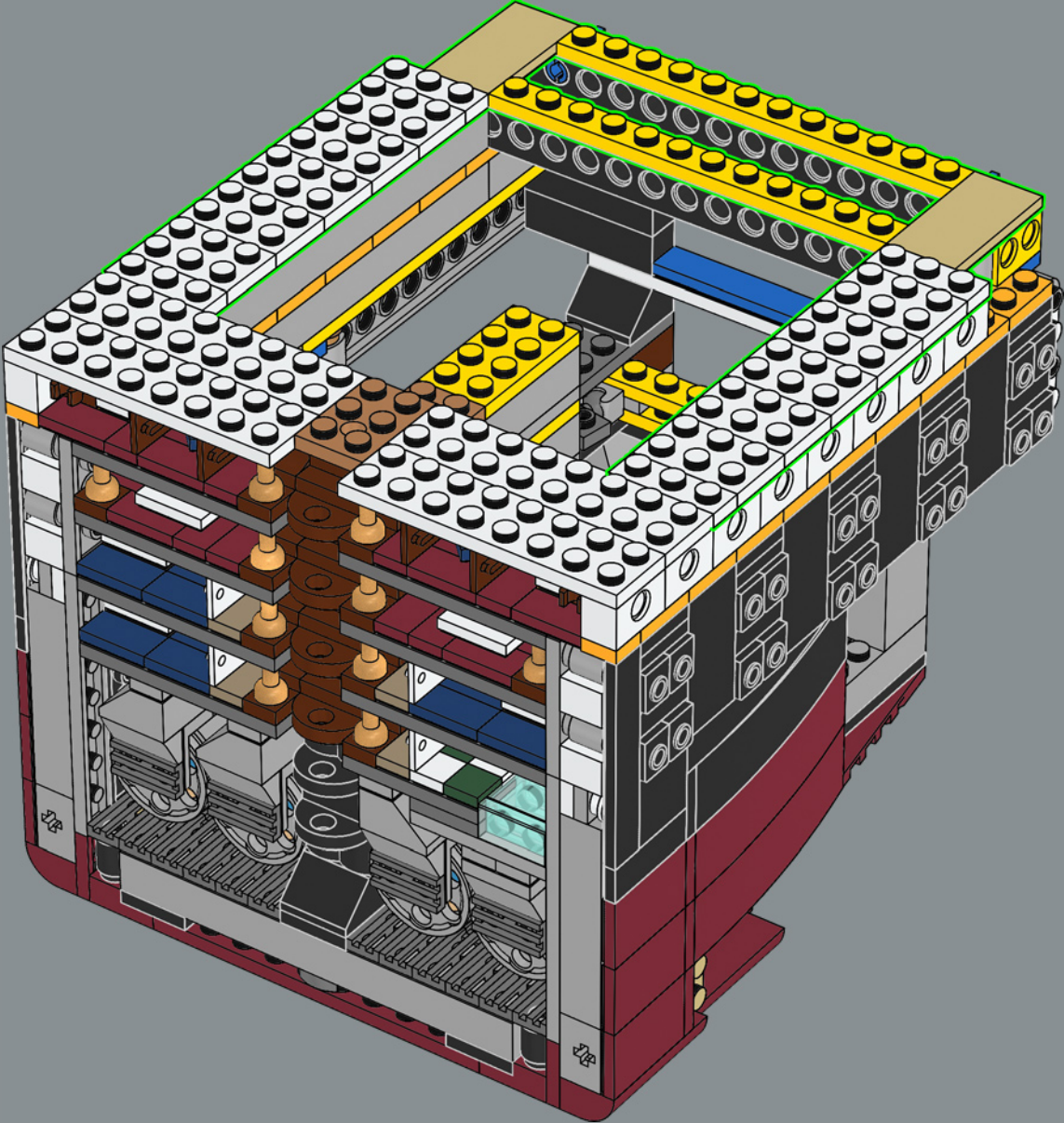

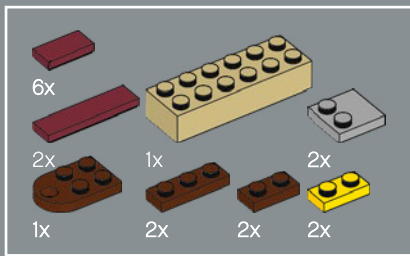

225

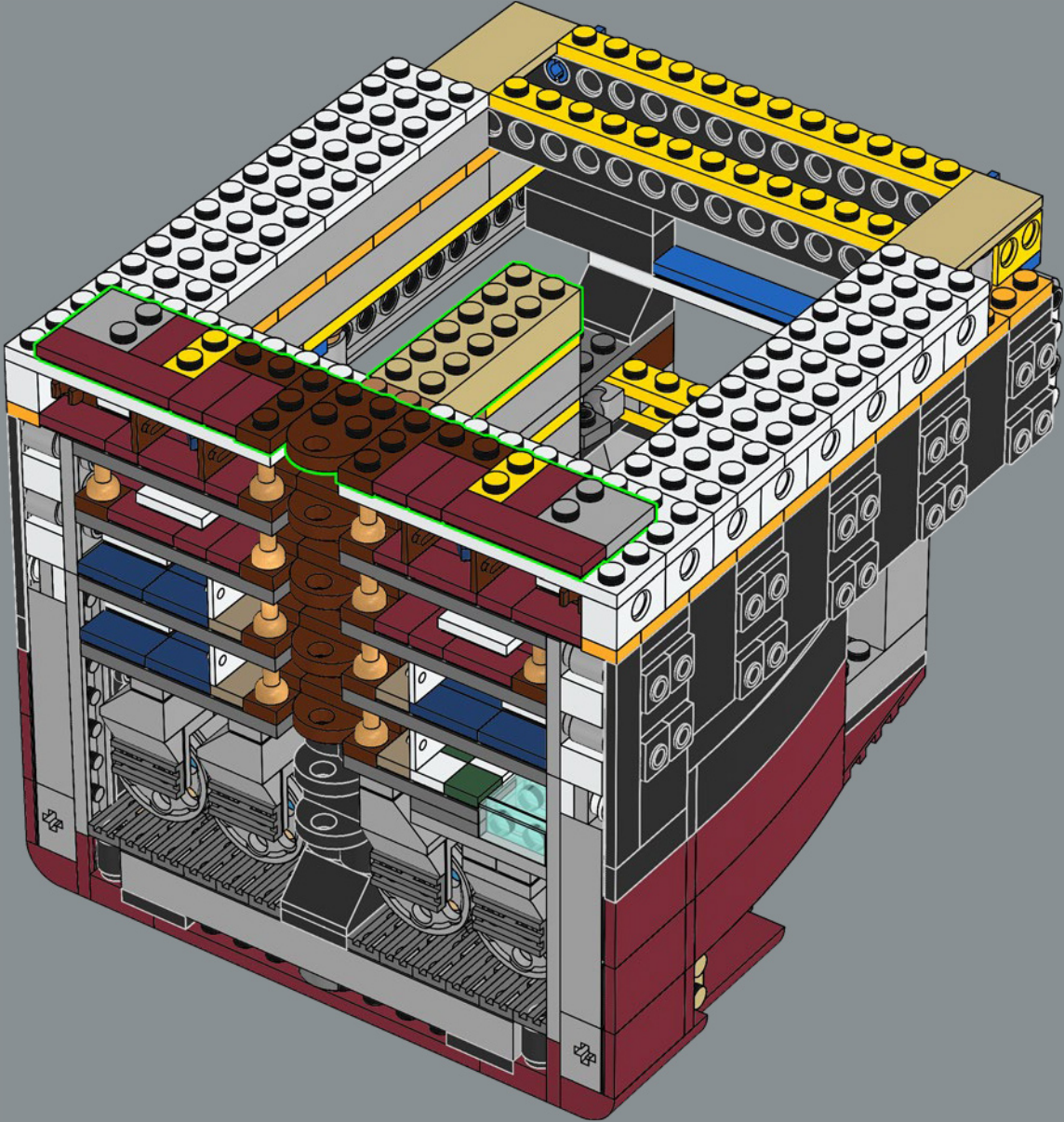

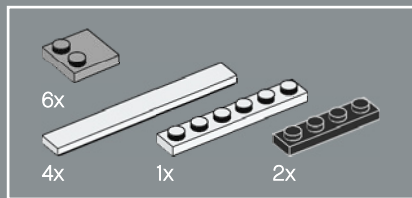

226

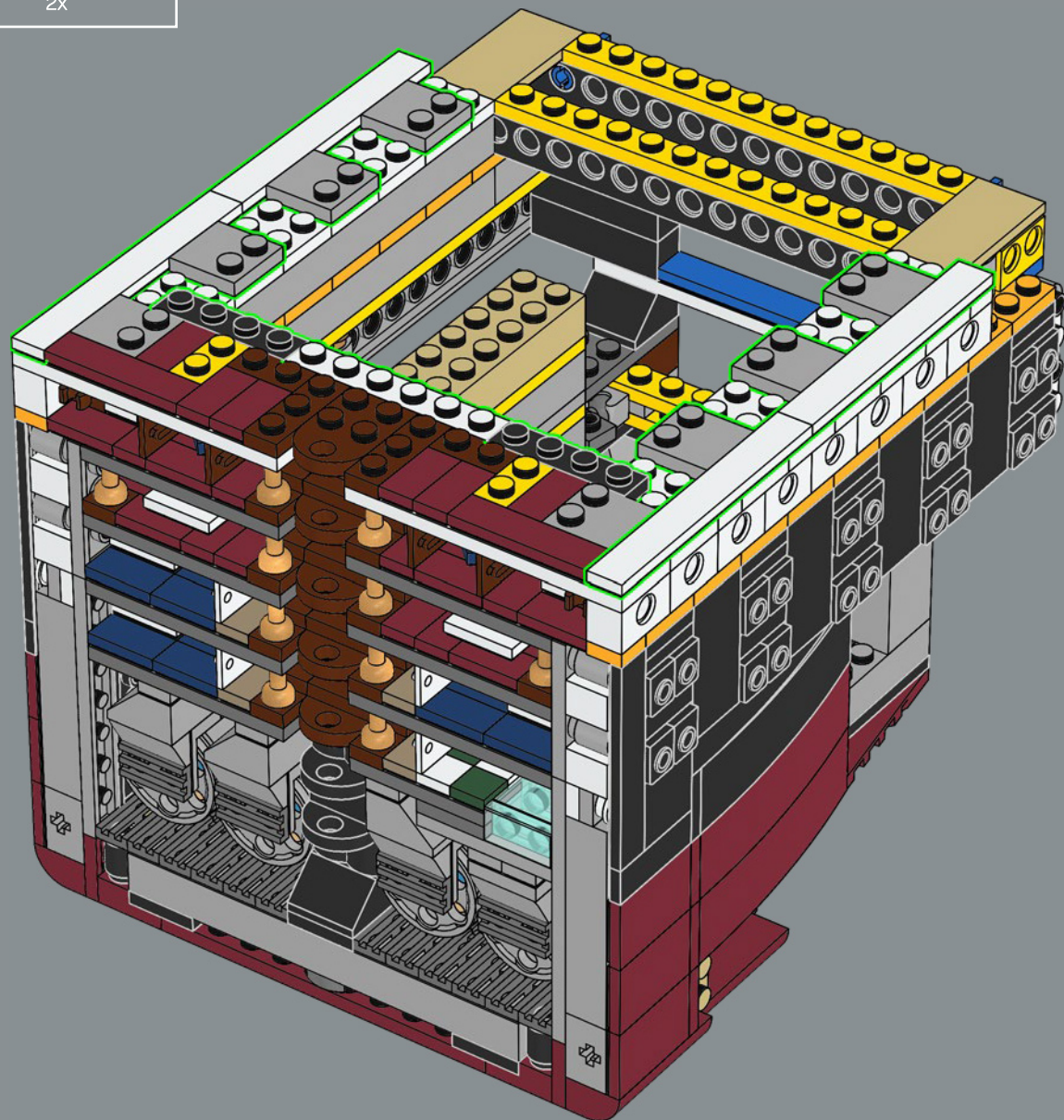

Le RMS Titanic transporte une grande quantité de marchandises pour le Royal Mail et le service postal américain, d'où les initiales RMS pour « Royal Mail Ship » (navire de la poste britannique).

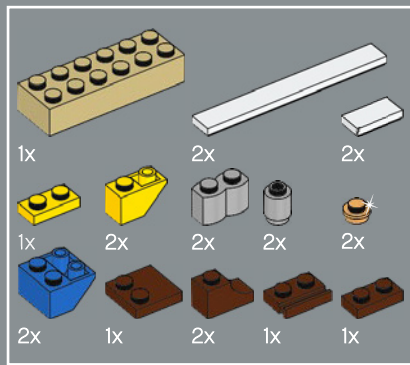

227

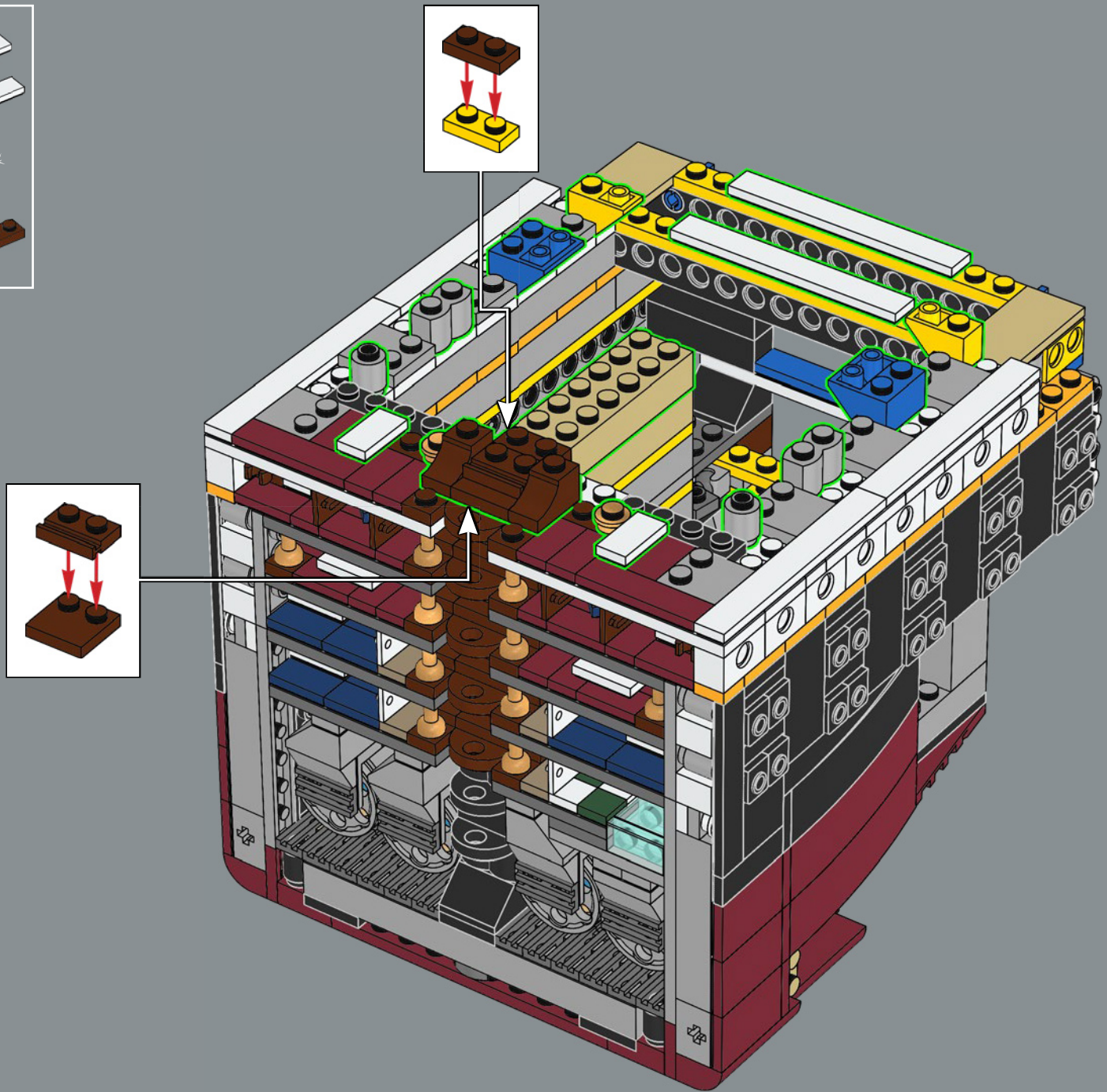

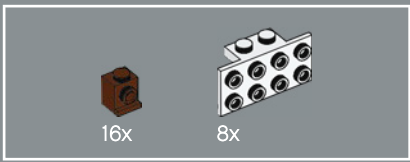

228

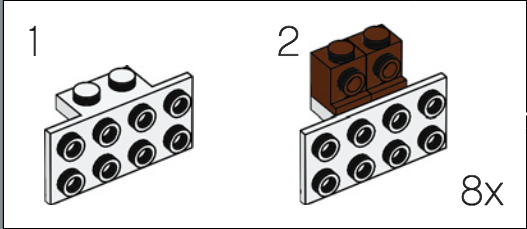
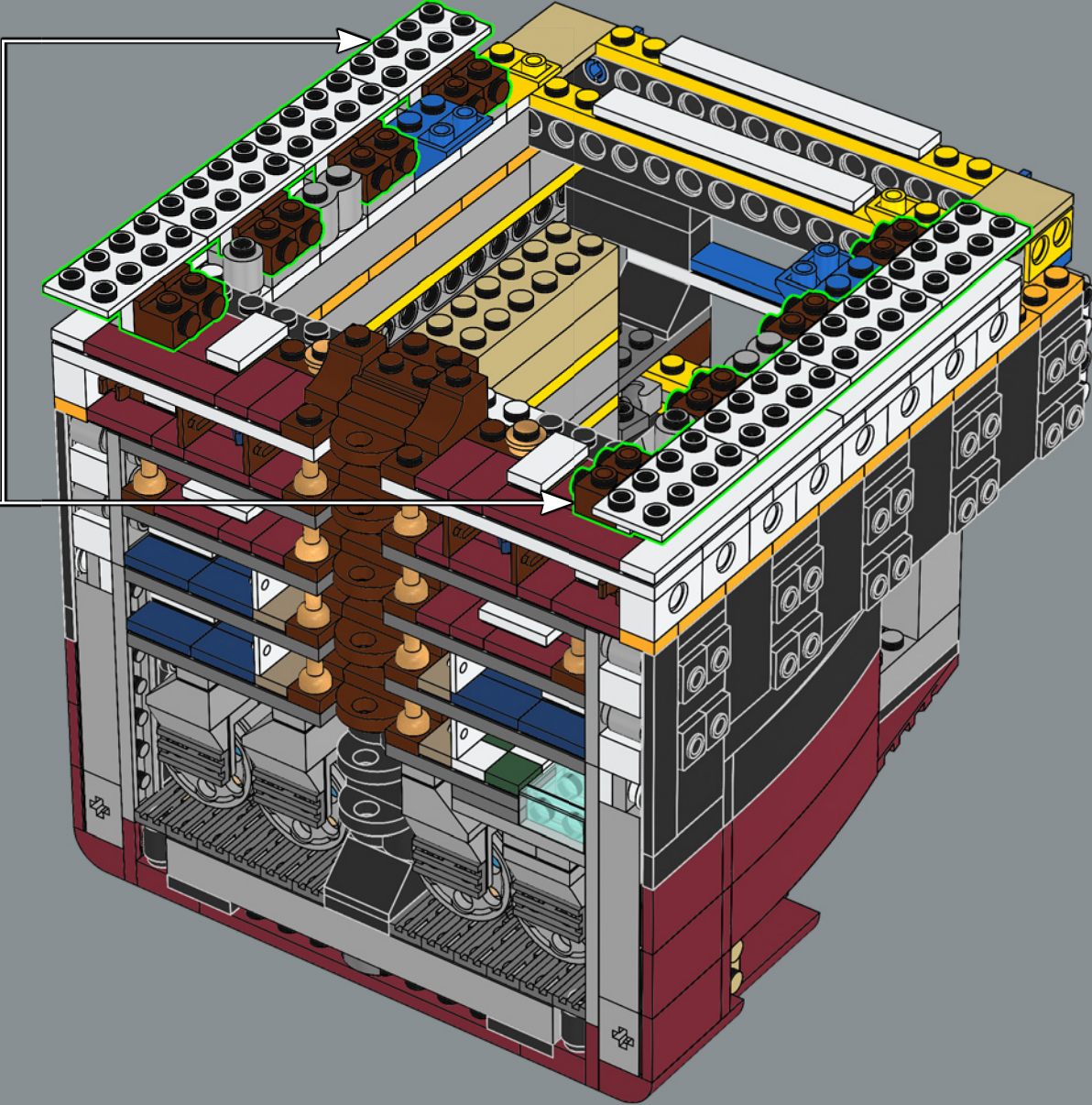



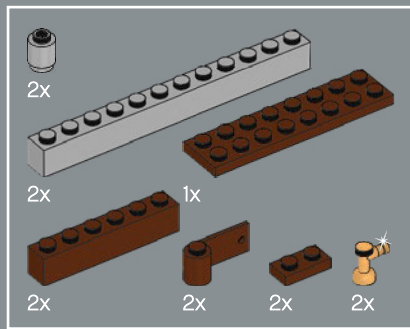

229

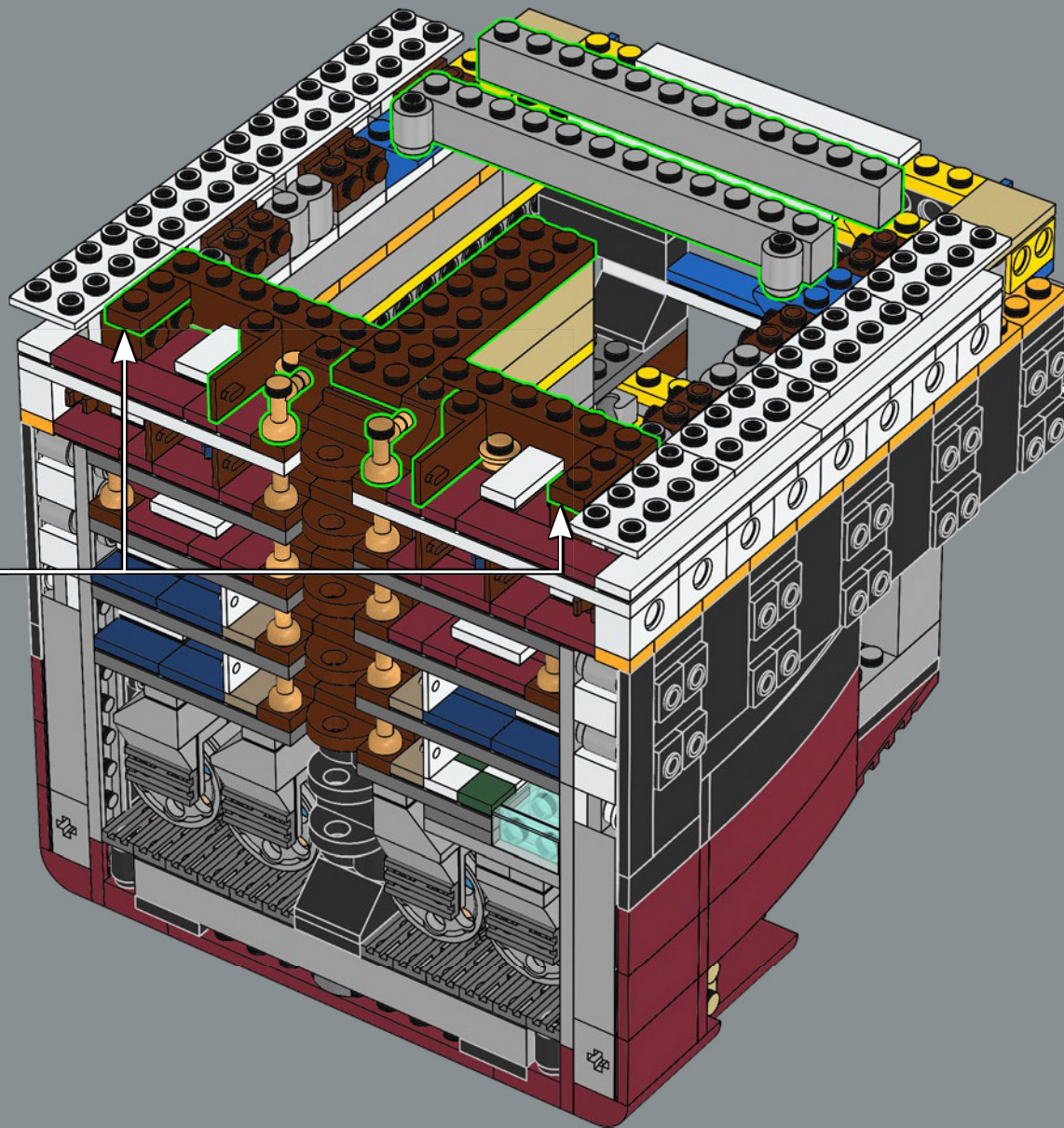

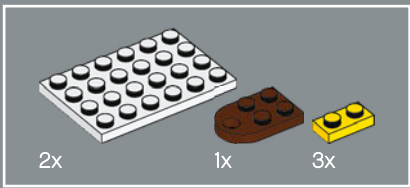

230

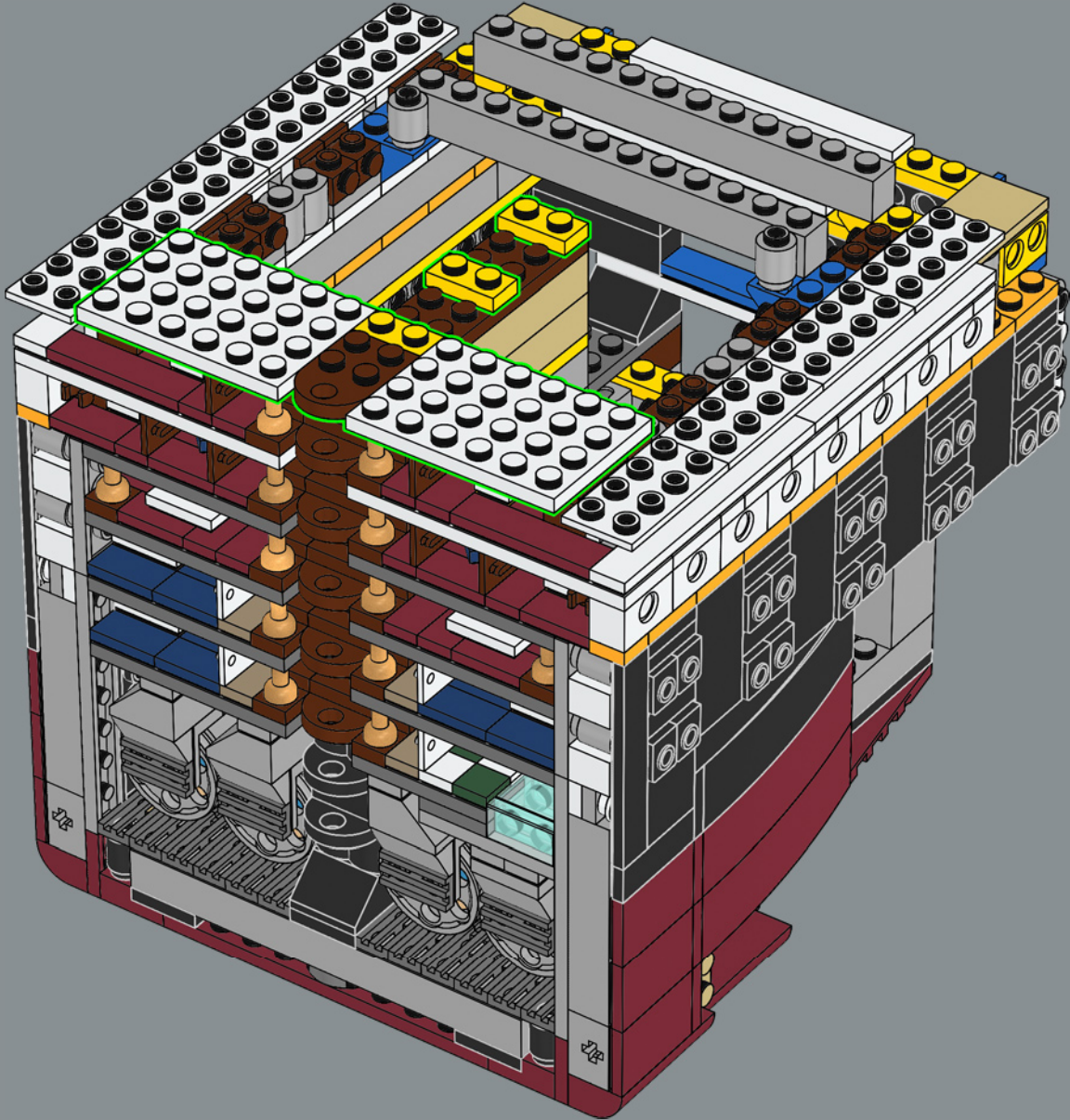

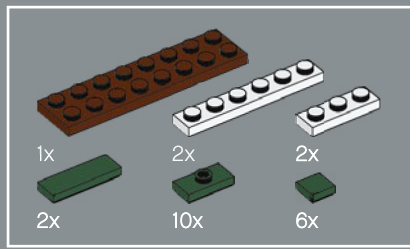

231

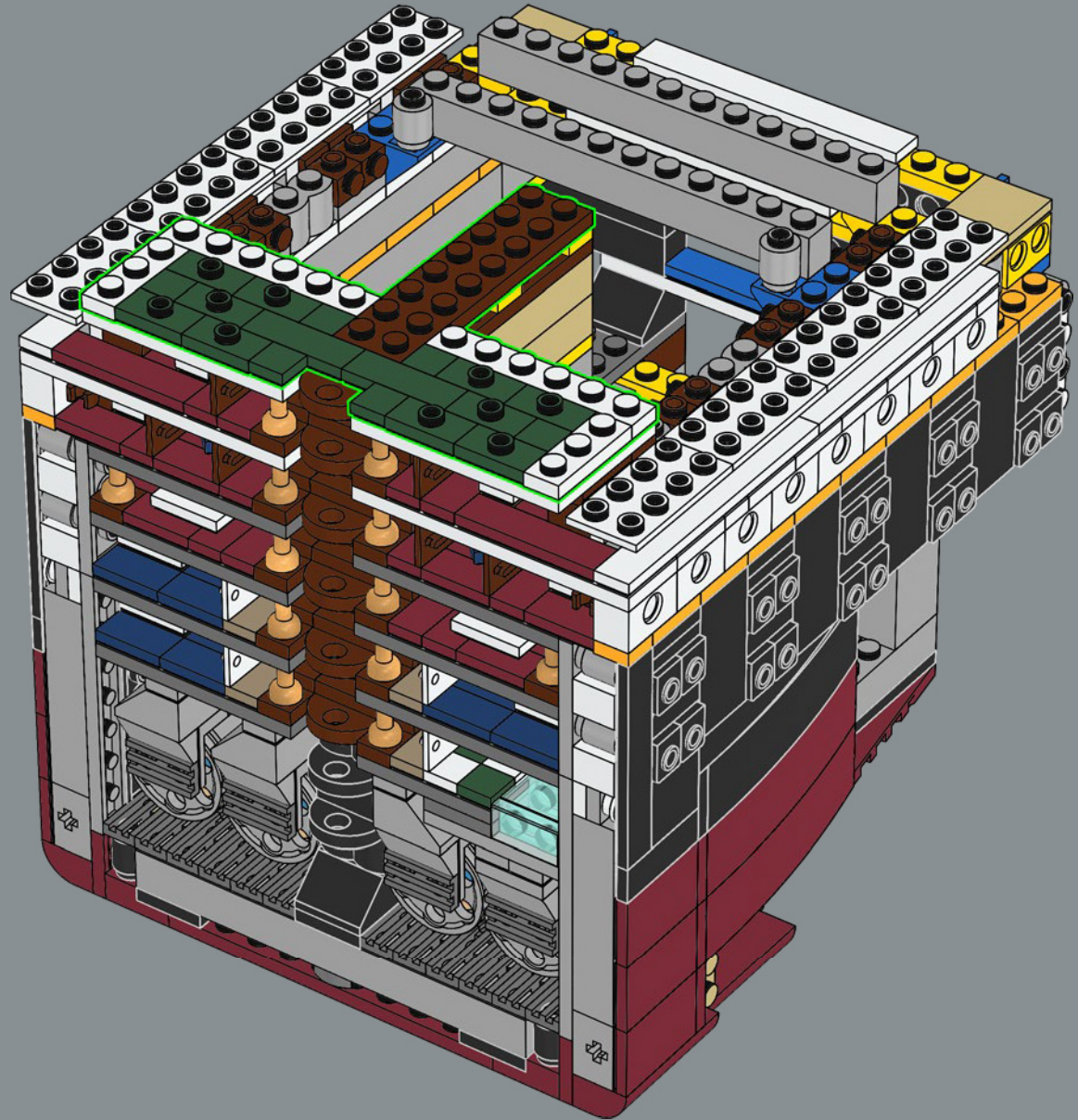

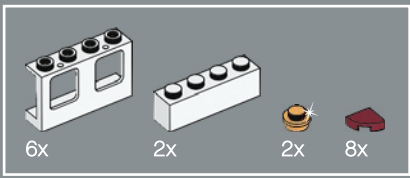

232

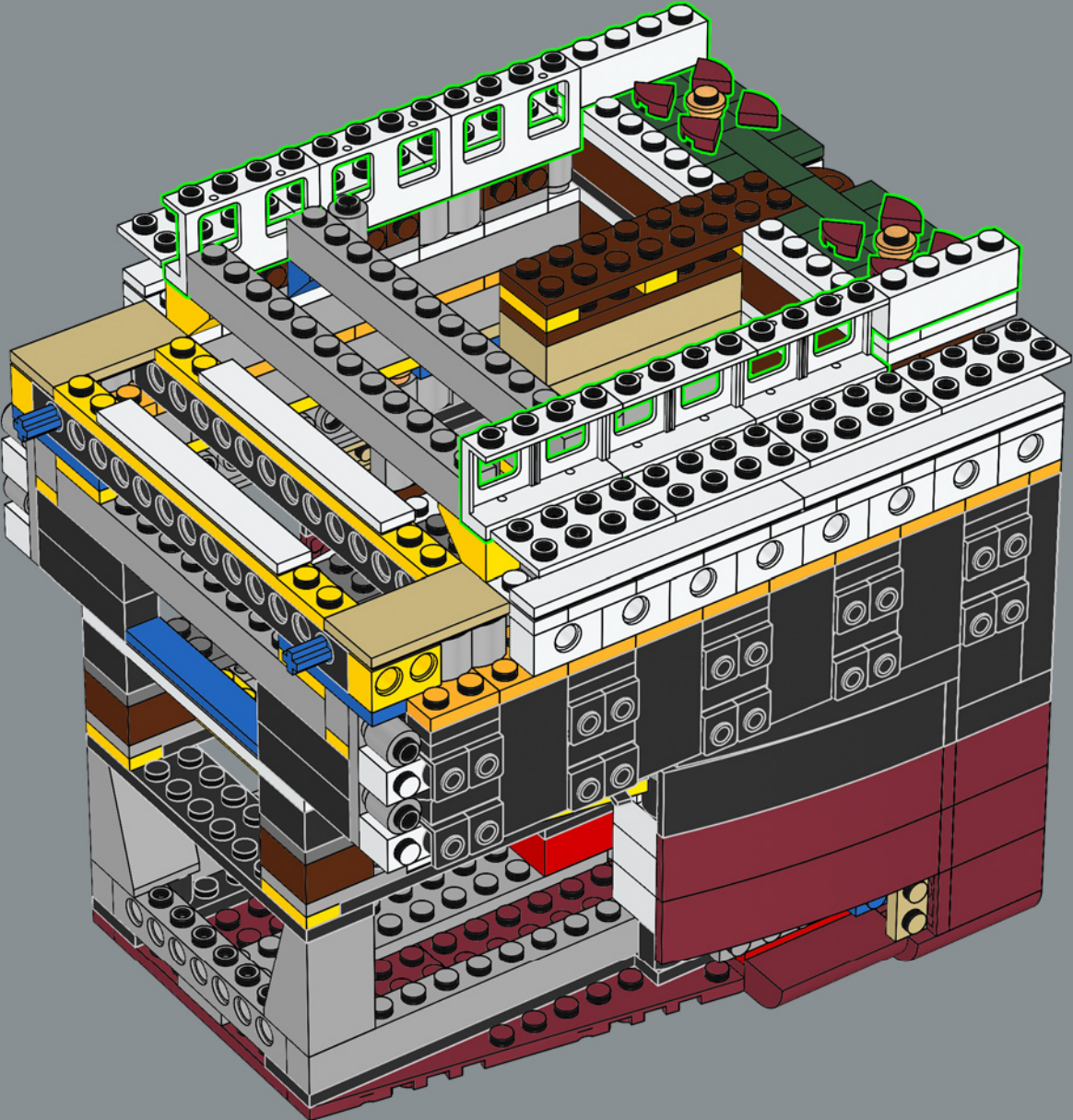

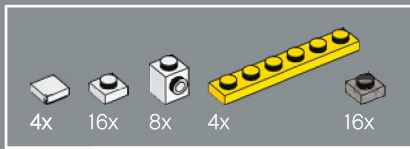

233

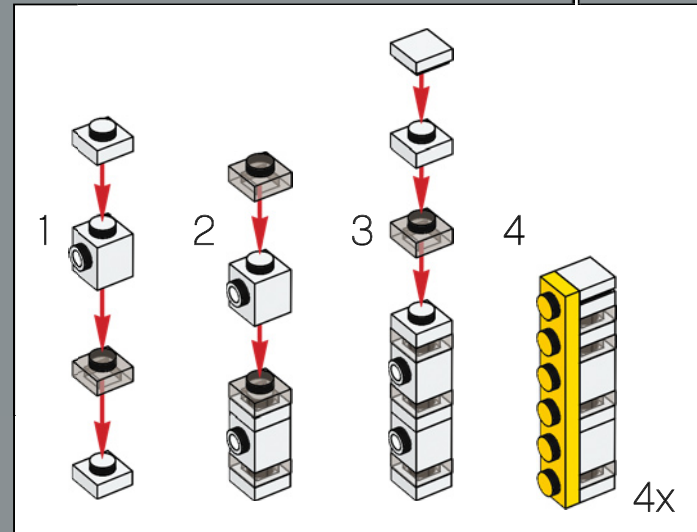
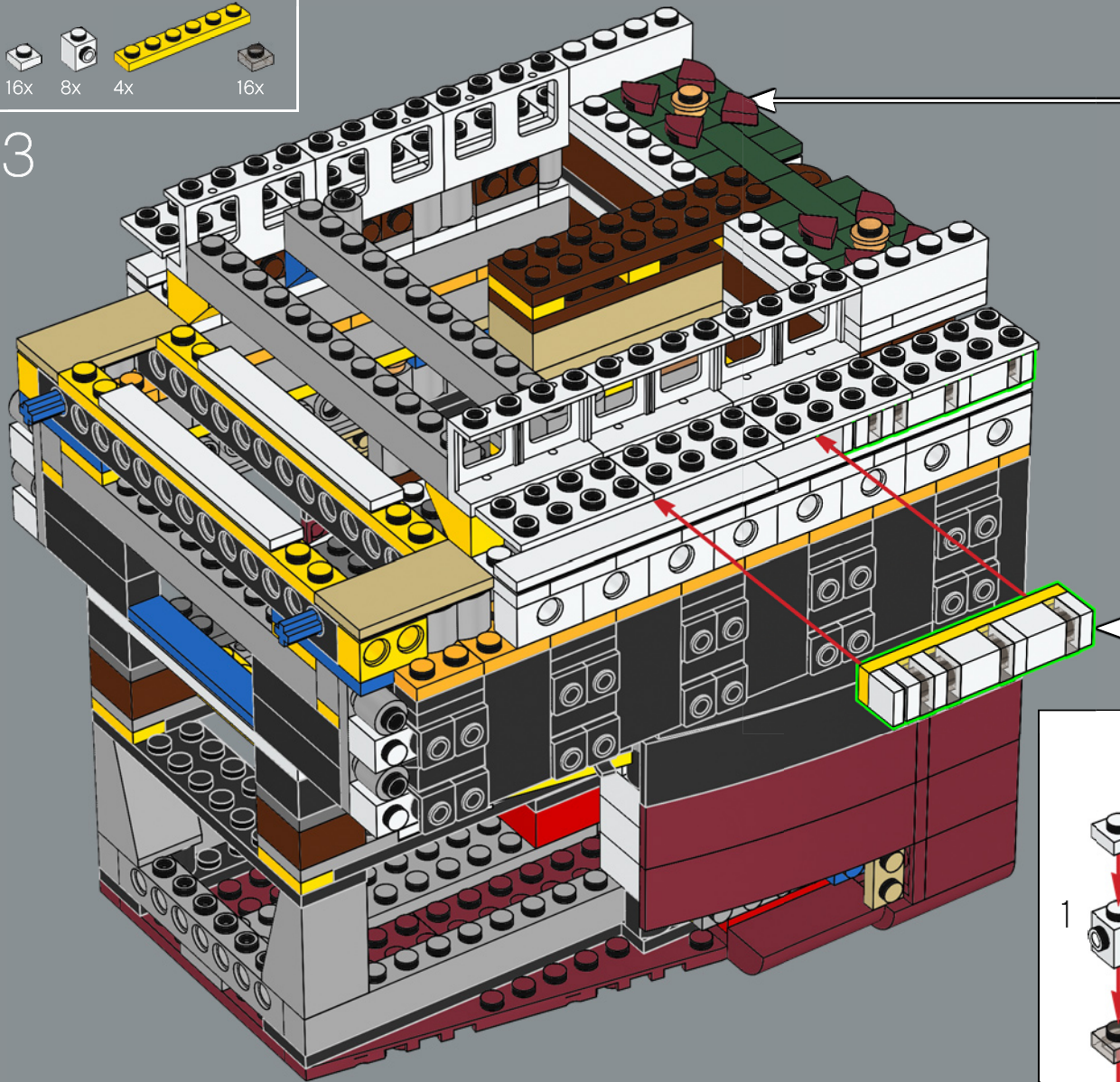

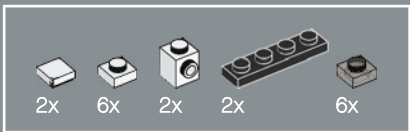

234

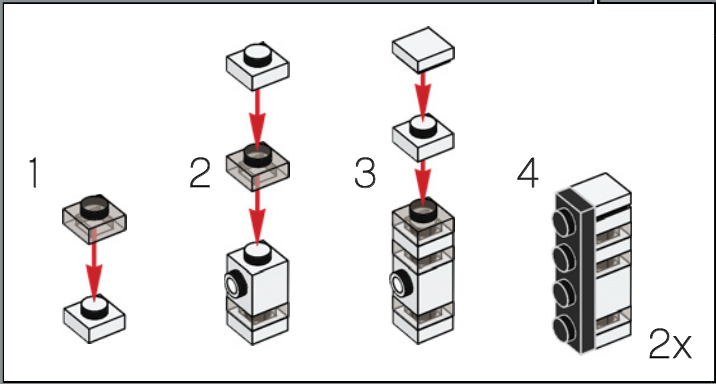
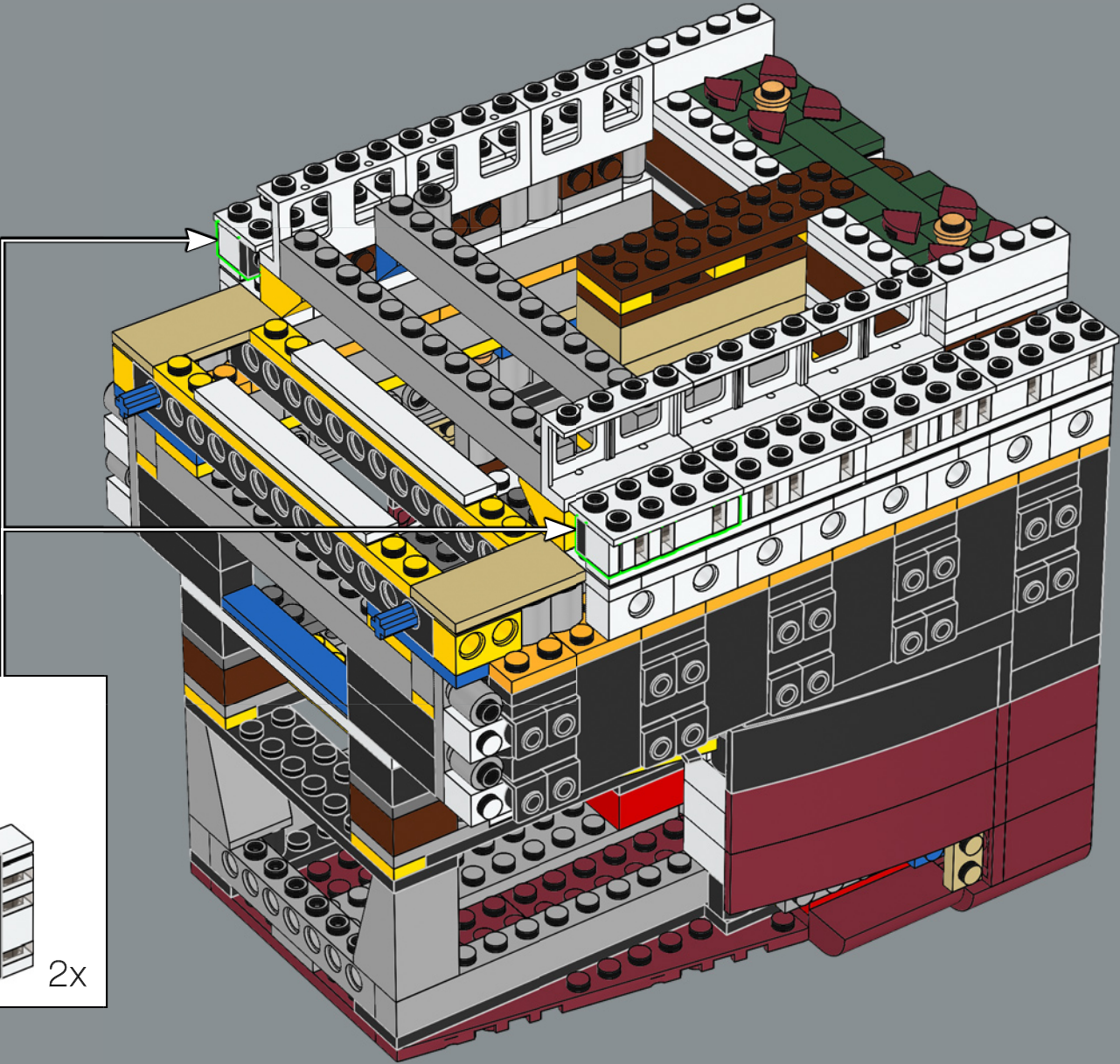

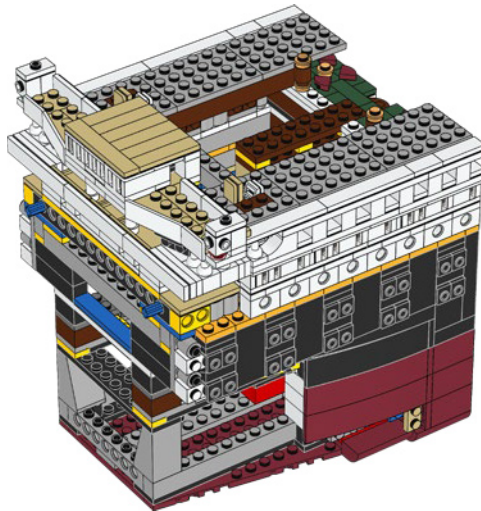
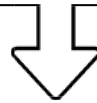

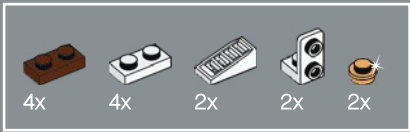

235

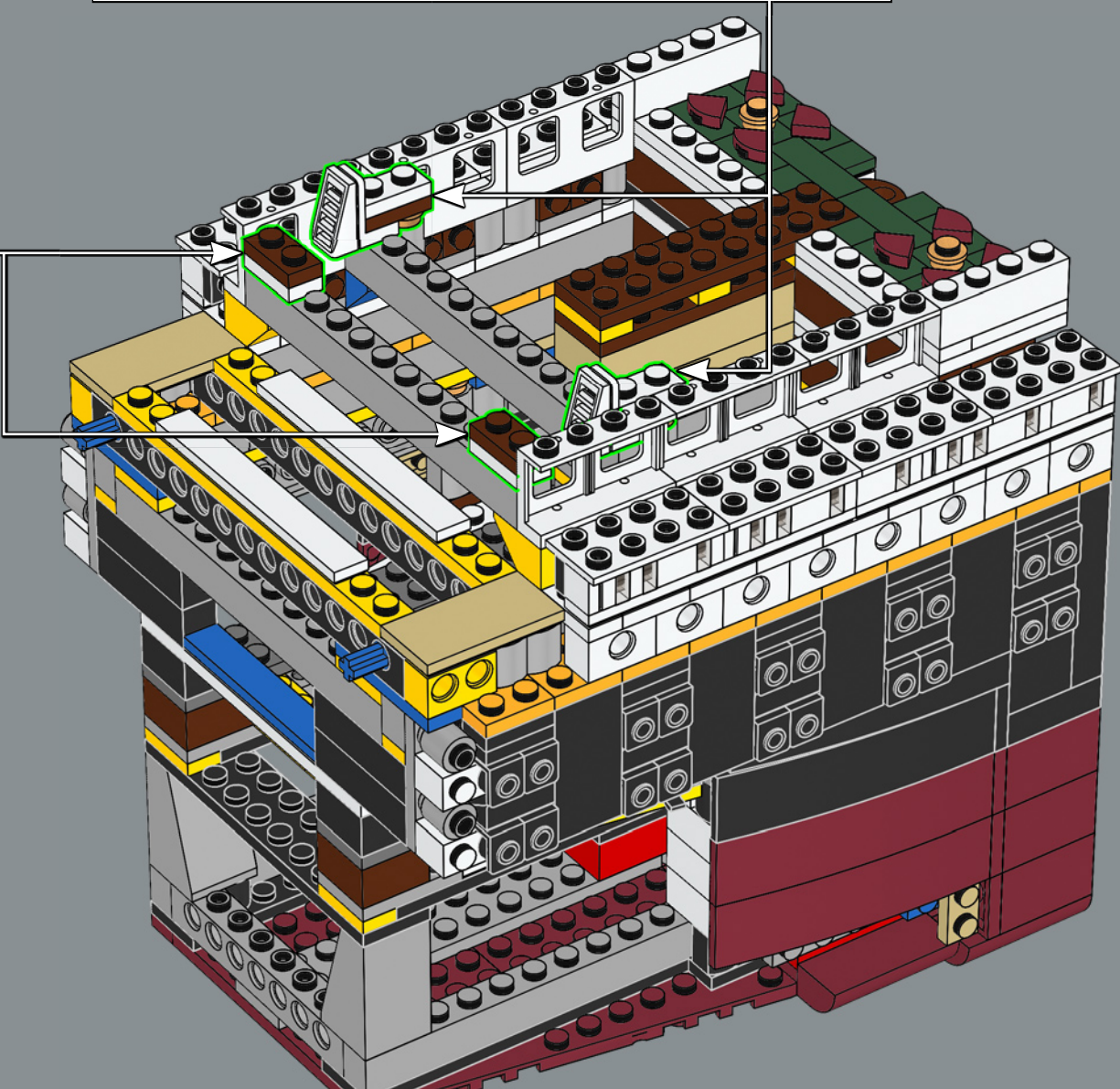
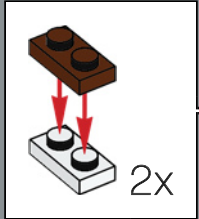
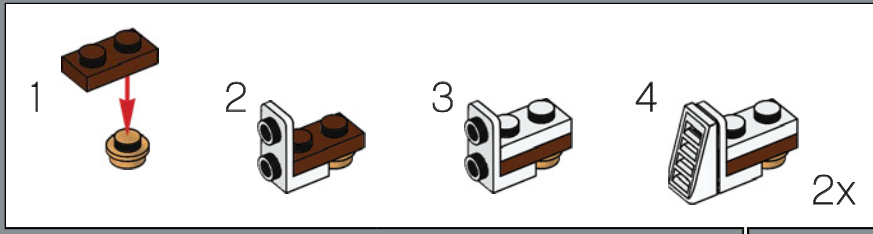



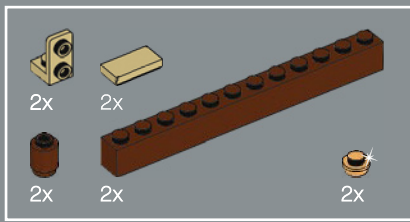

236

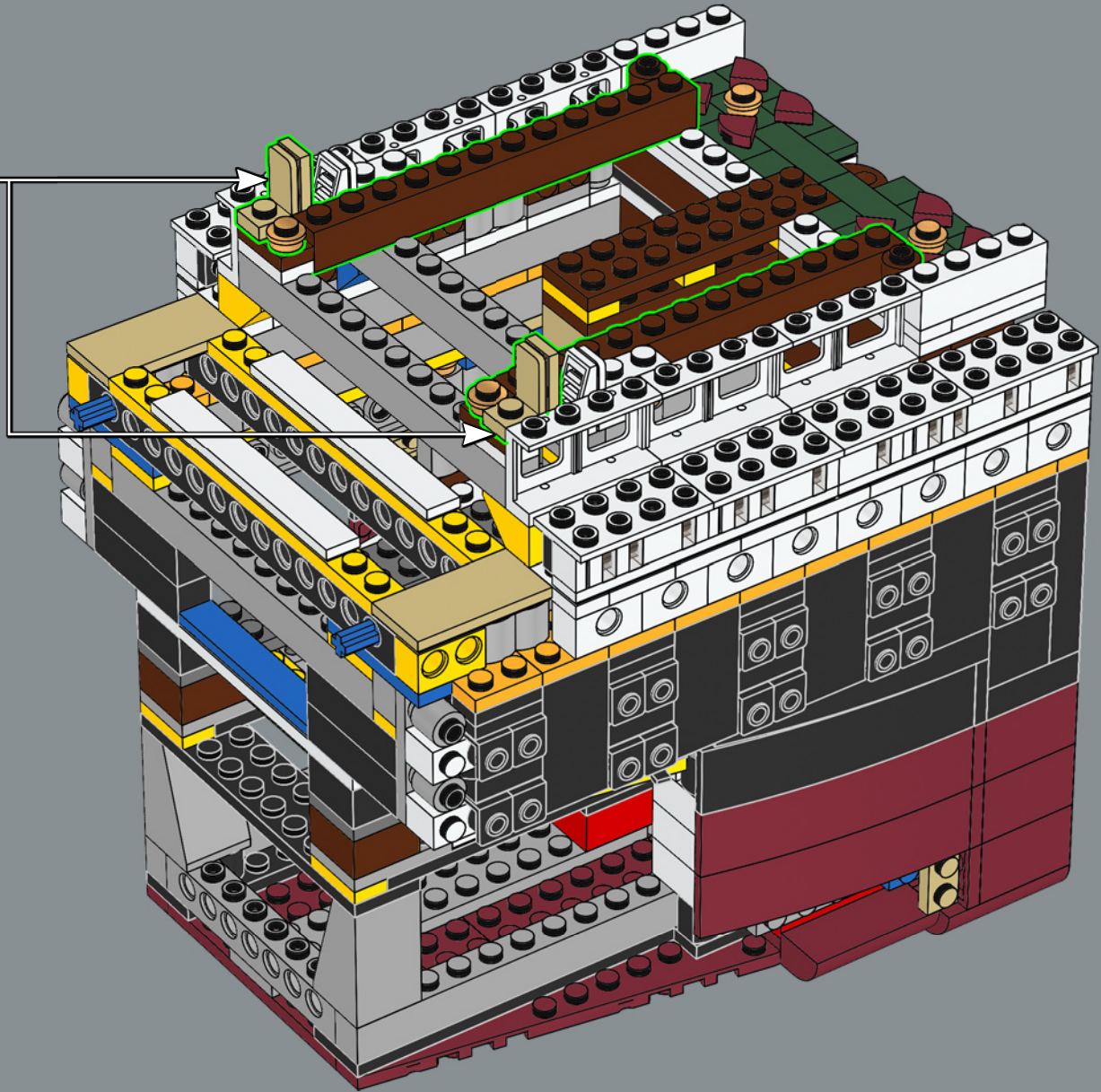
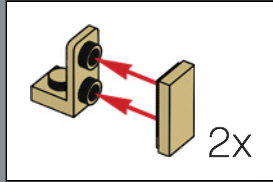

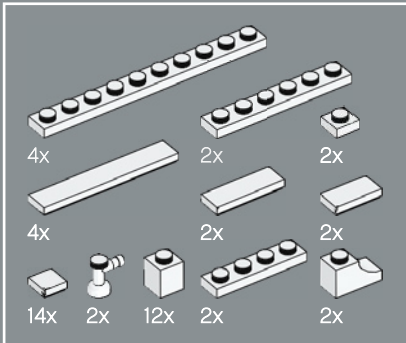
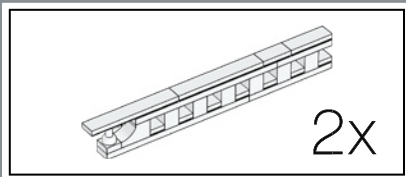

237

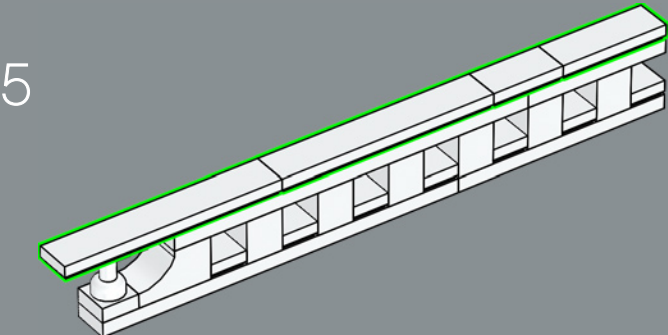
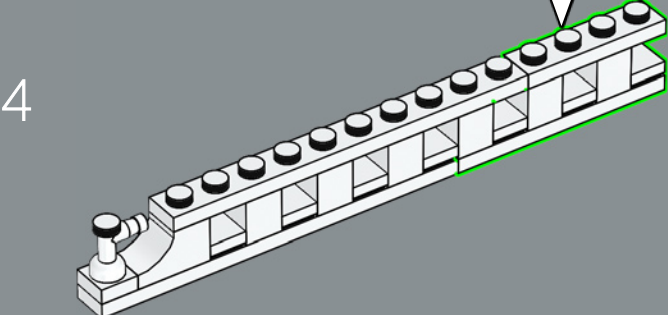
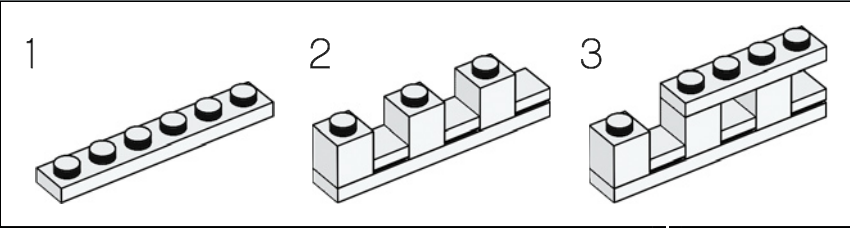
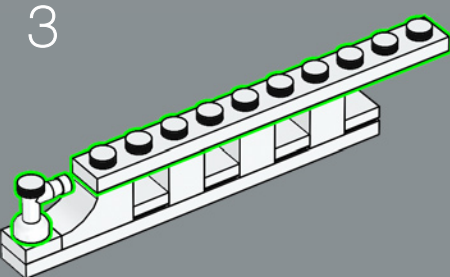
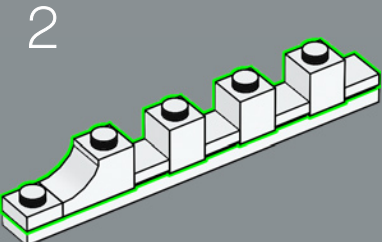
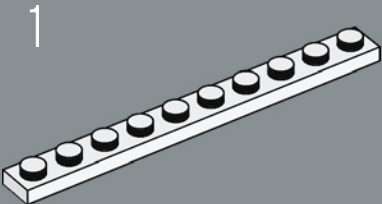

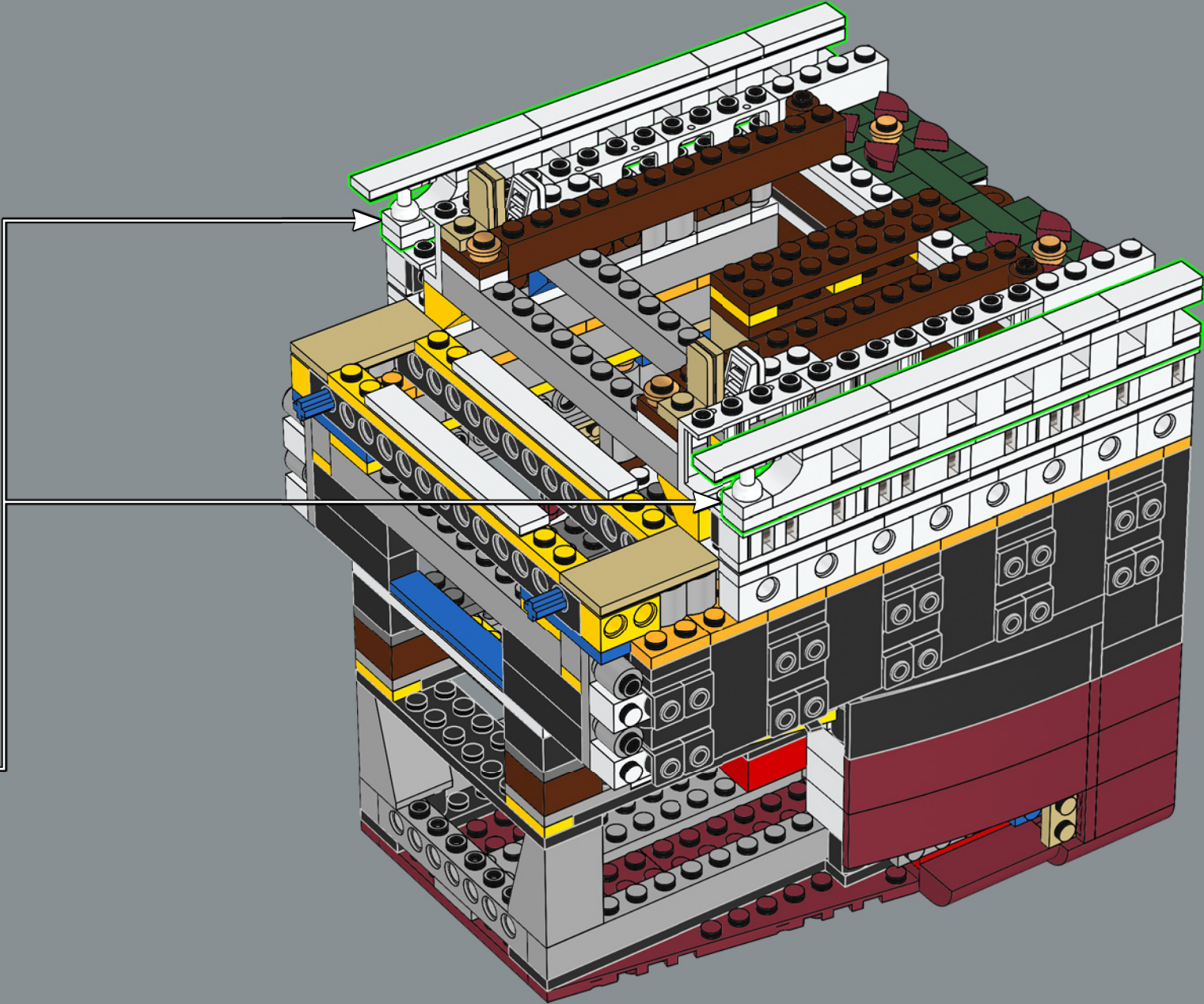

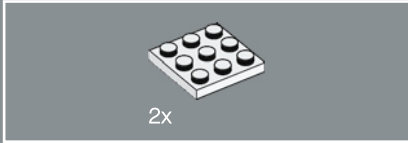
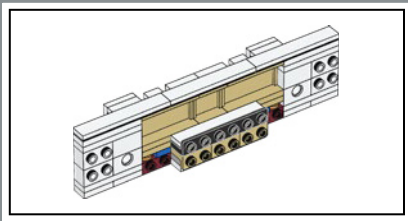

238

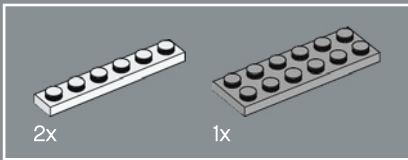
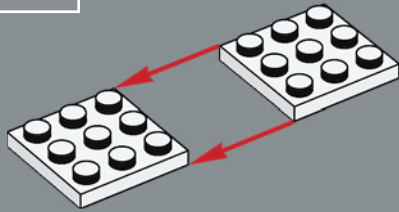

239

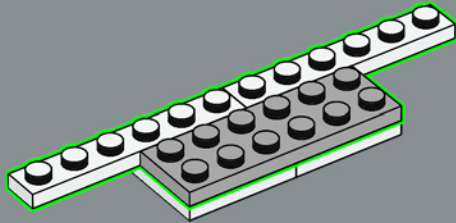

240

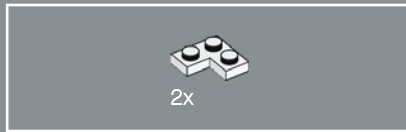
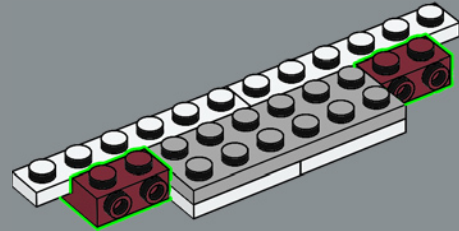

241

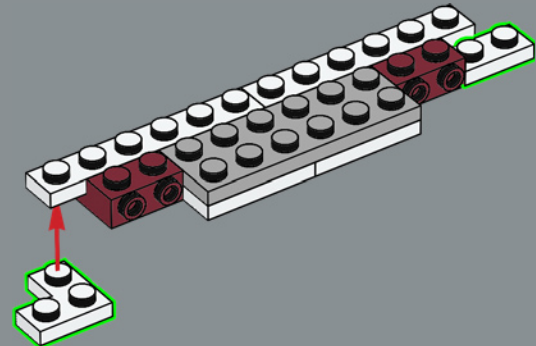

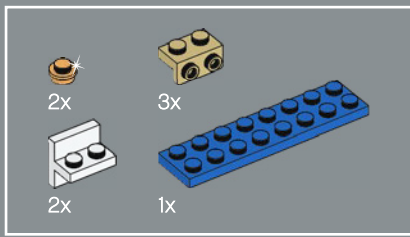

242

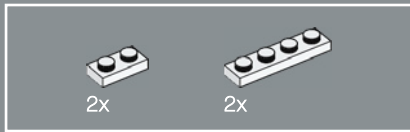
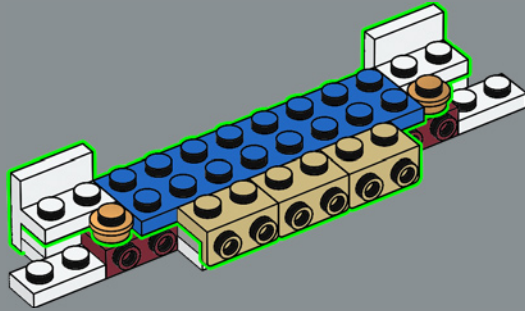

243

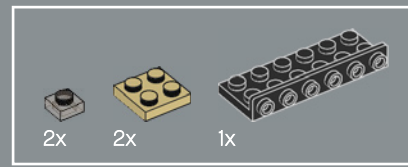
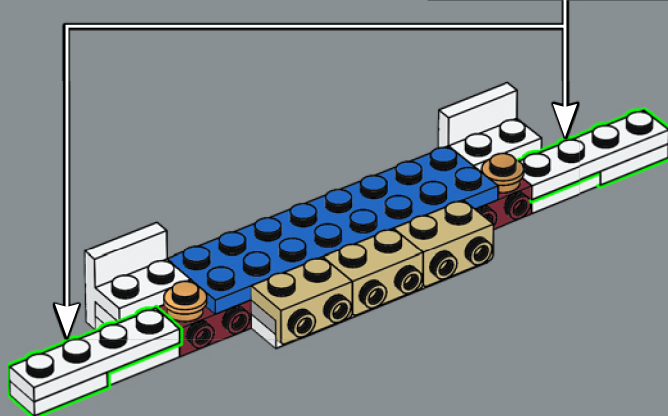
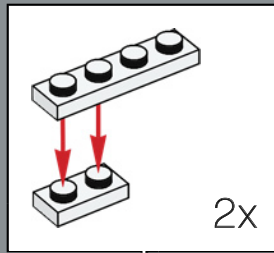

244

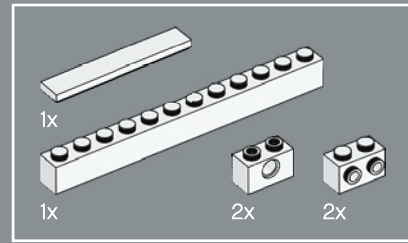
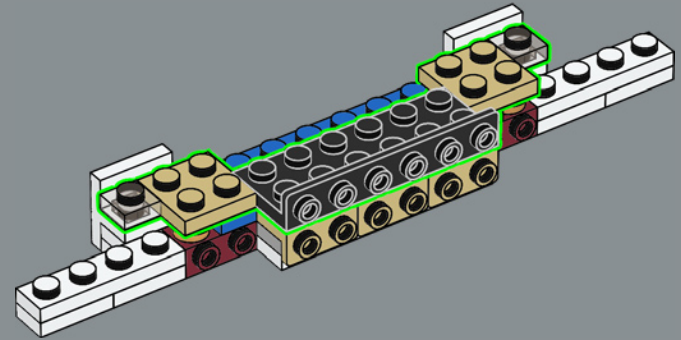

245

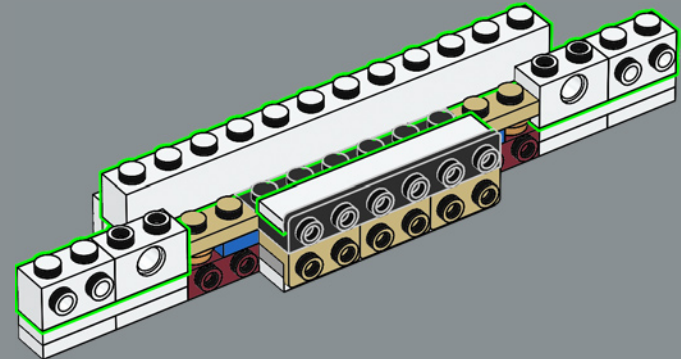

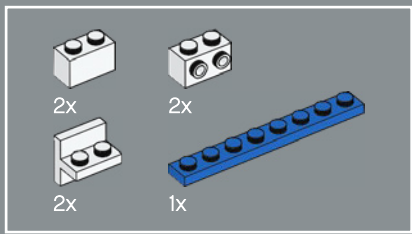

246

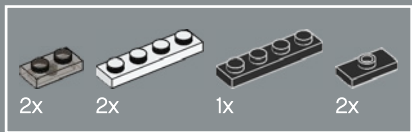
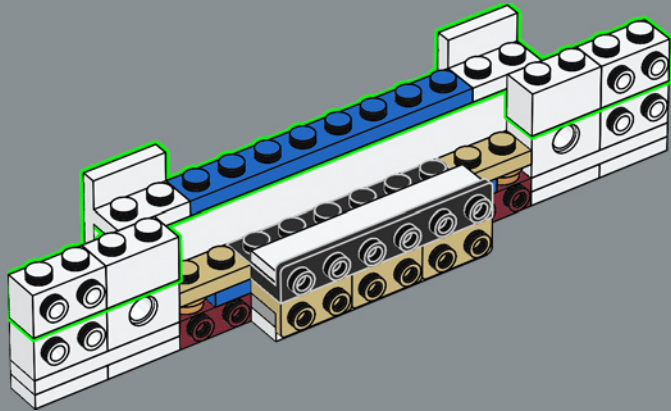

247

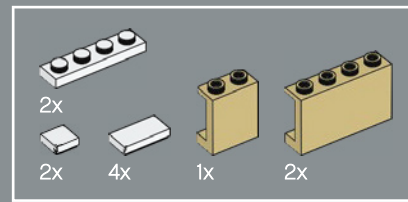
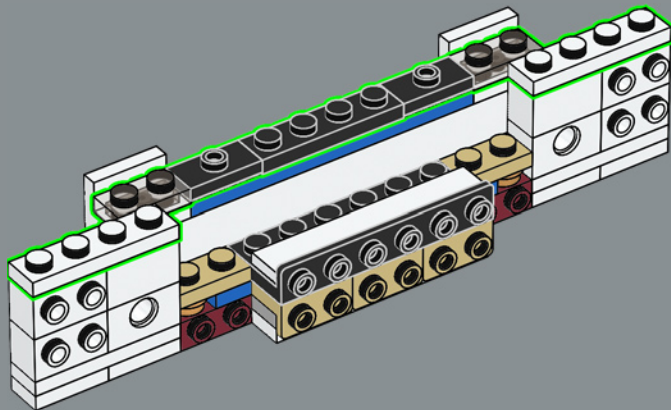

248

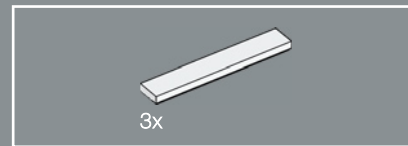
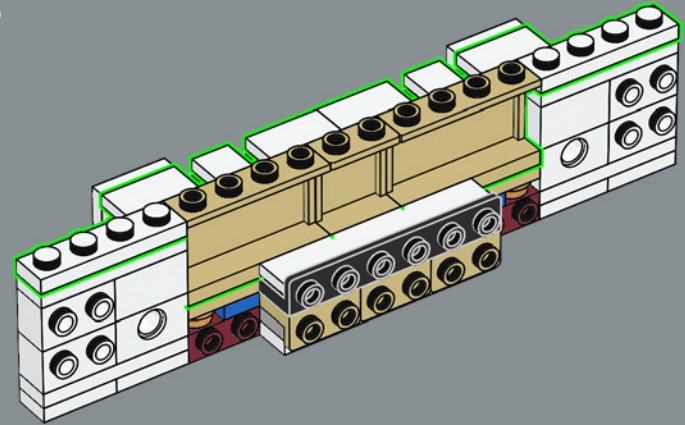

249

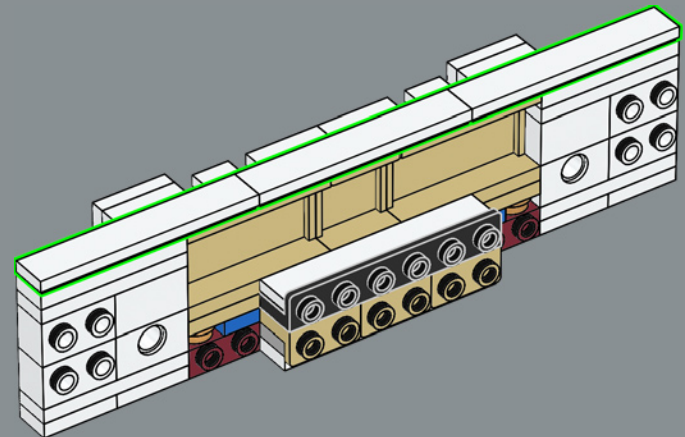

250

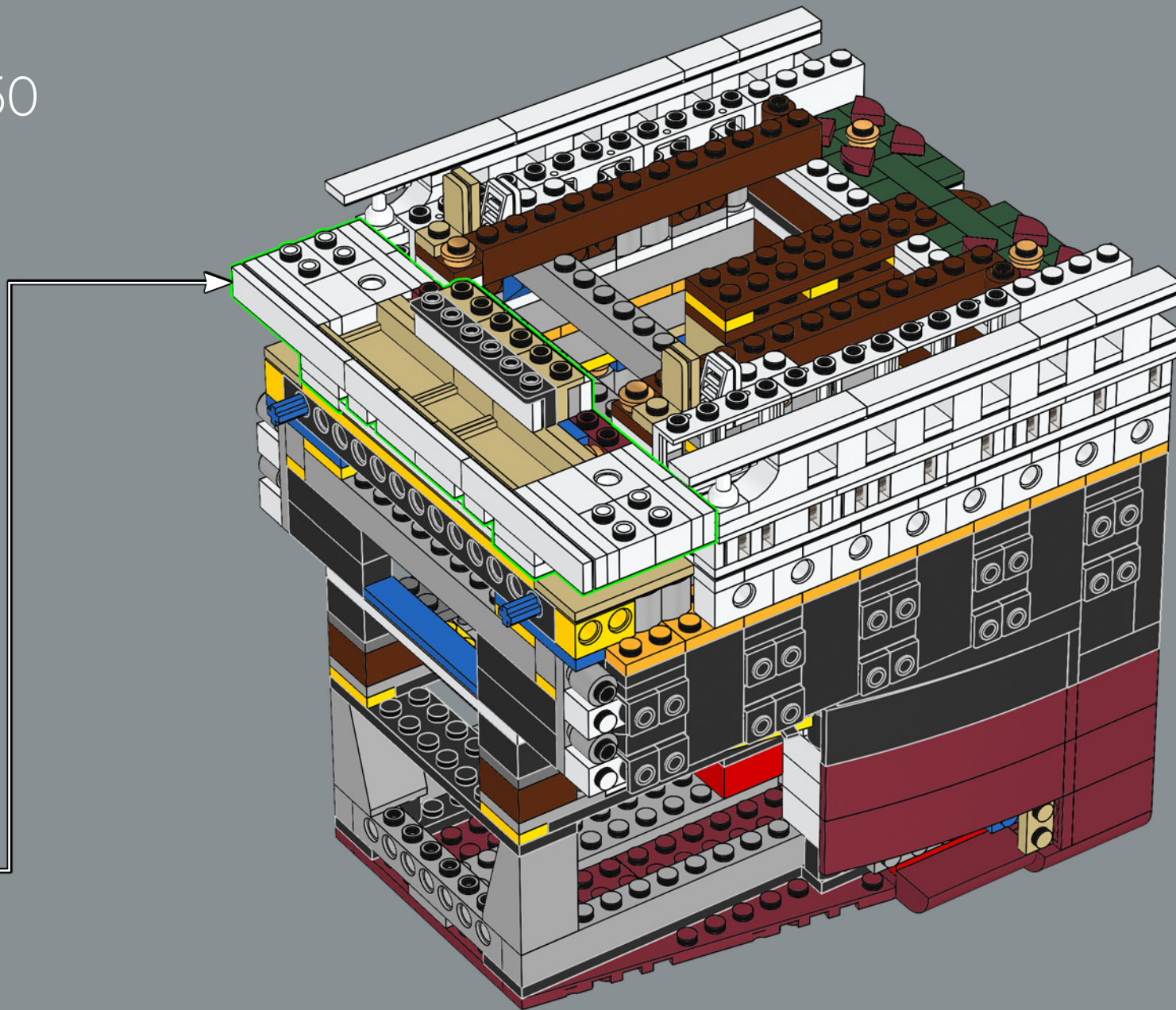

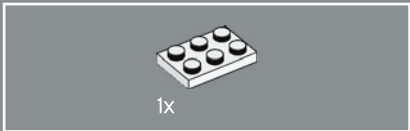
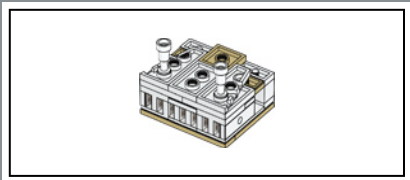

1x

251

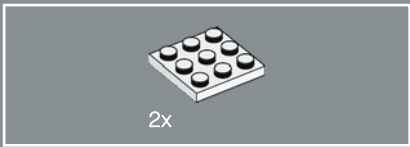

2x

252

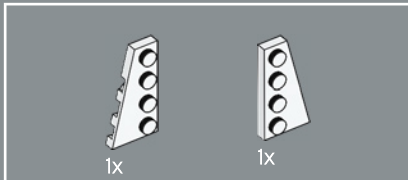
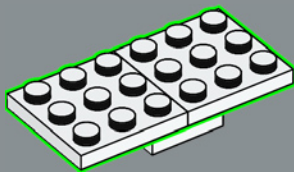

1x

1x

253

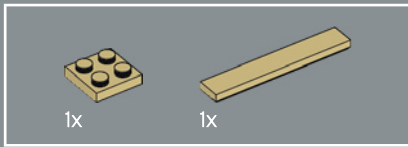
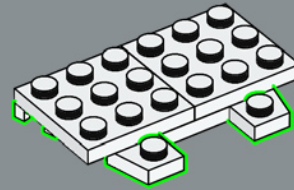

1x

1x

254

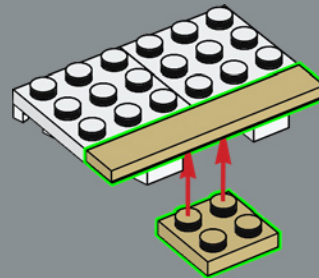



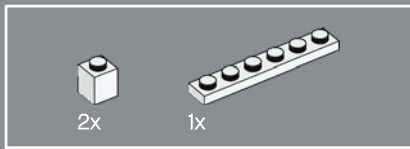

255

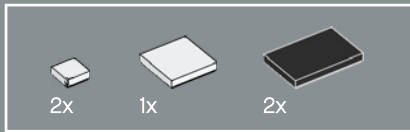
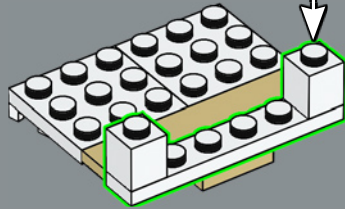
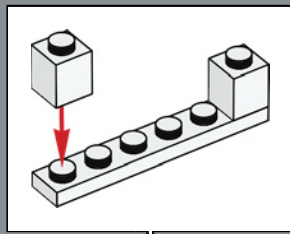

256

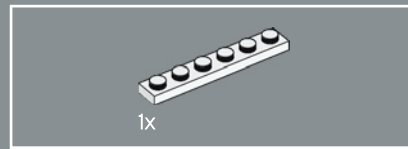
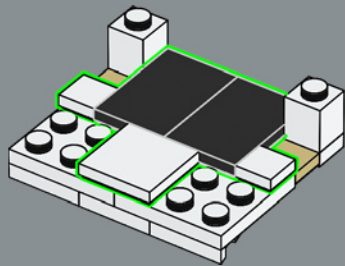

257

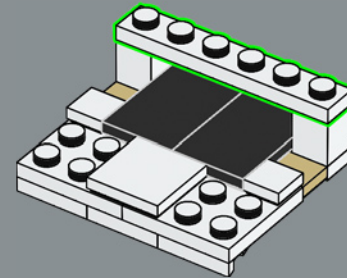



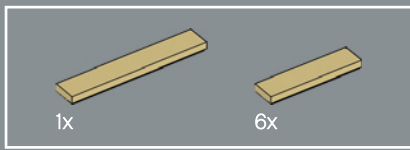

259

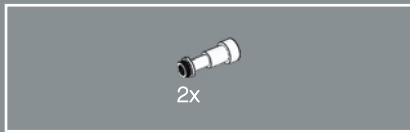
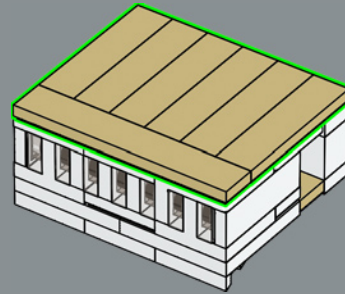

260

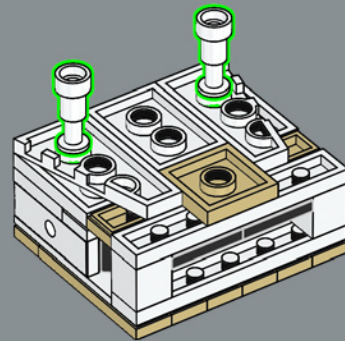

Le pont se trouve à 2,4 mètres au-dessus du pont promenade et s'étend de chaque côté afin que le navire puisse être contrôlé pendant l'accostage.

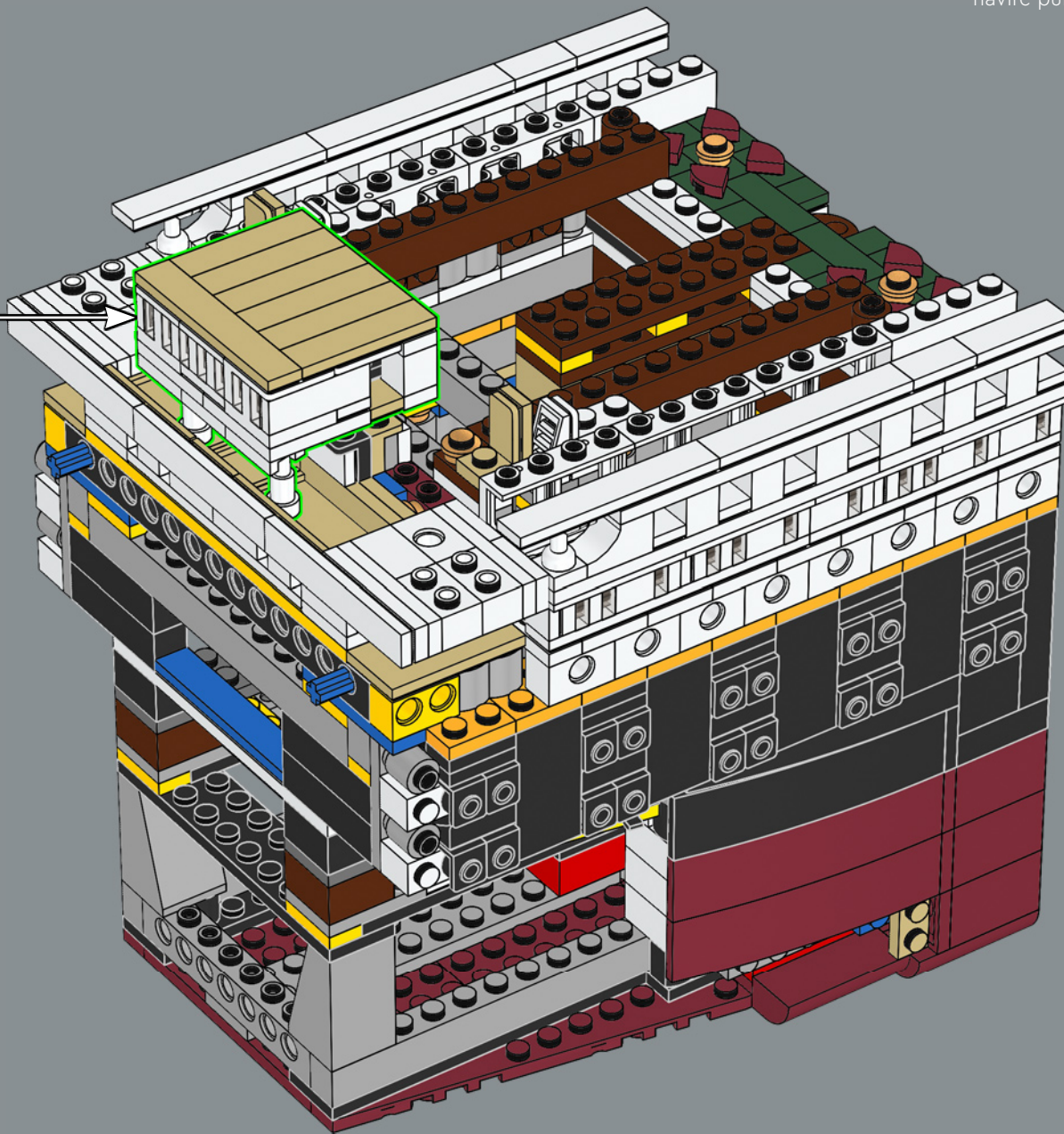



262

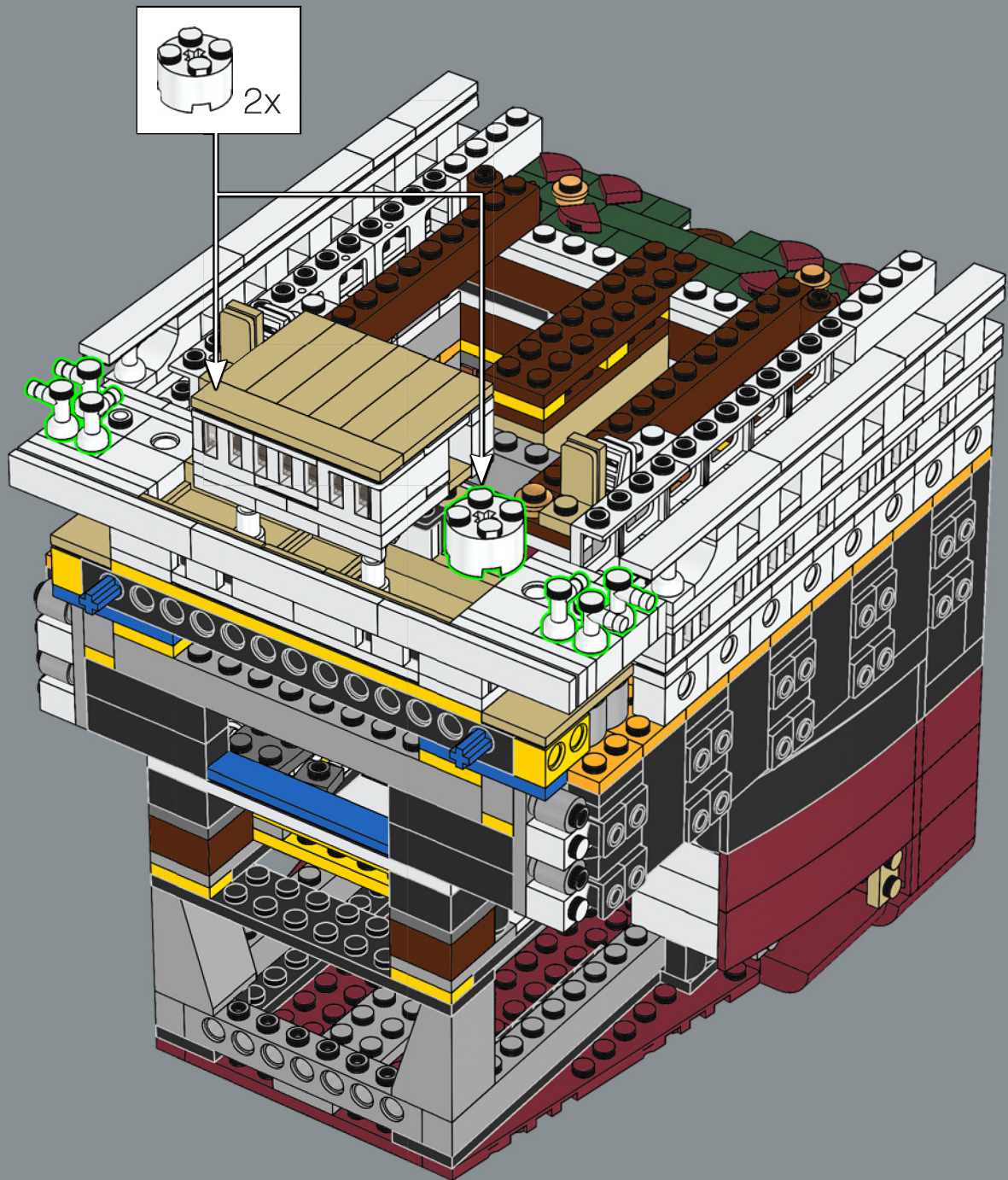

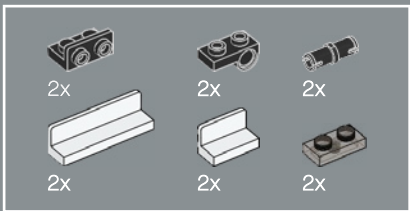

263

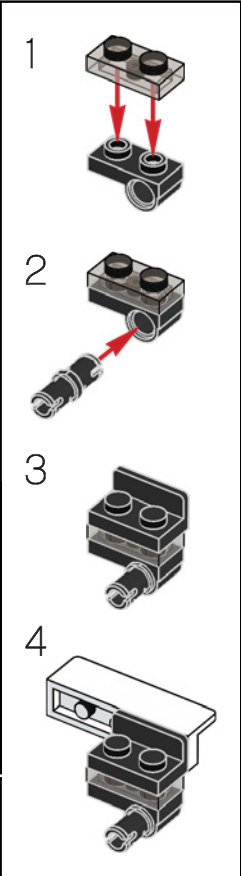
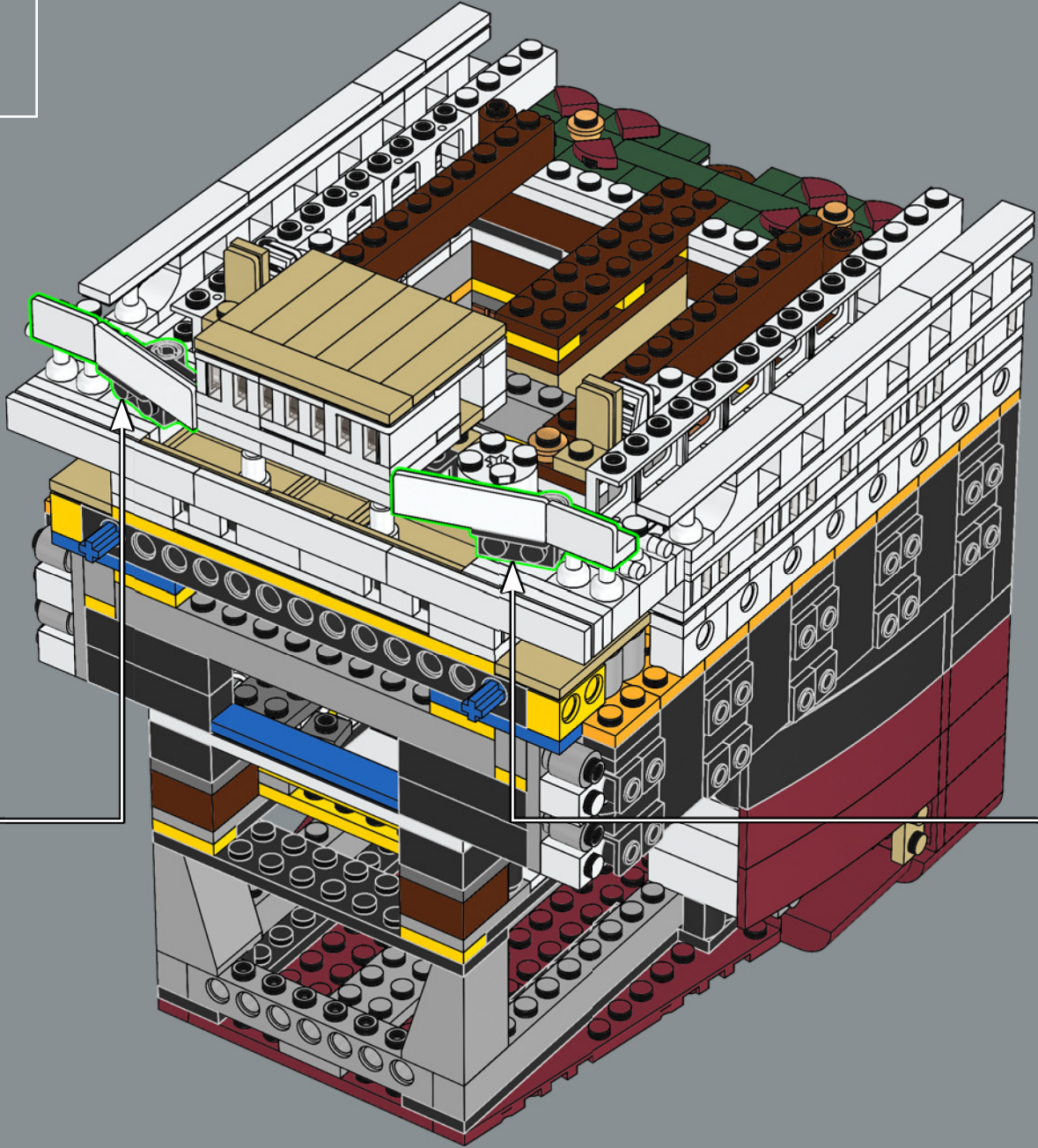
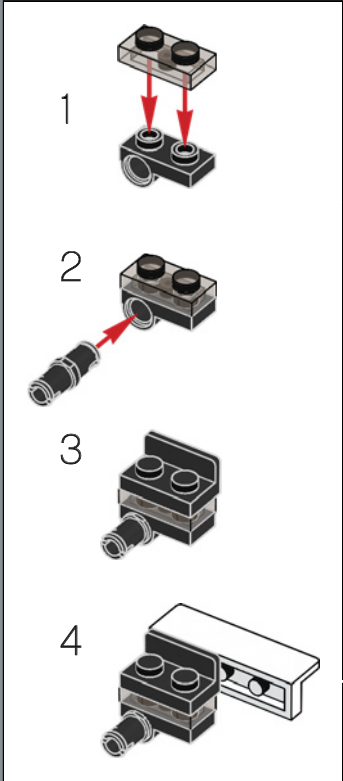

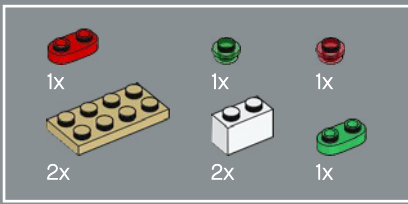

264

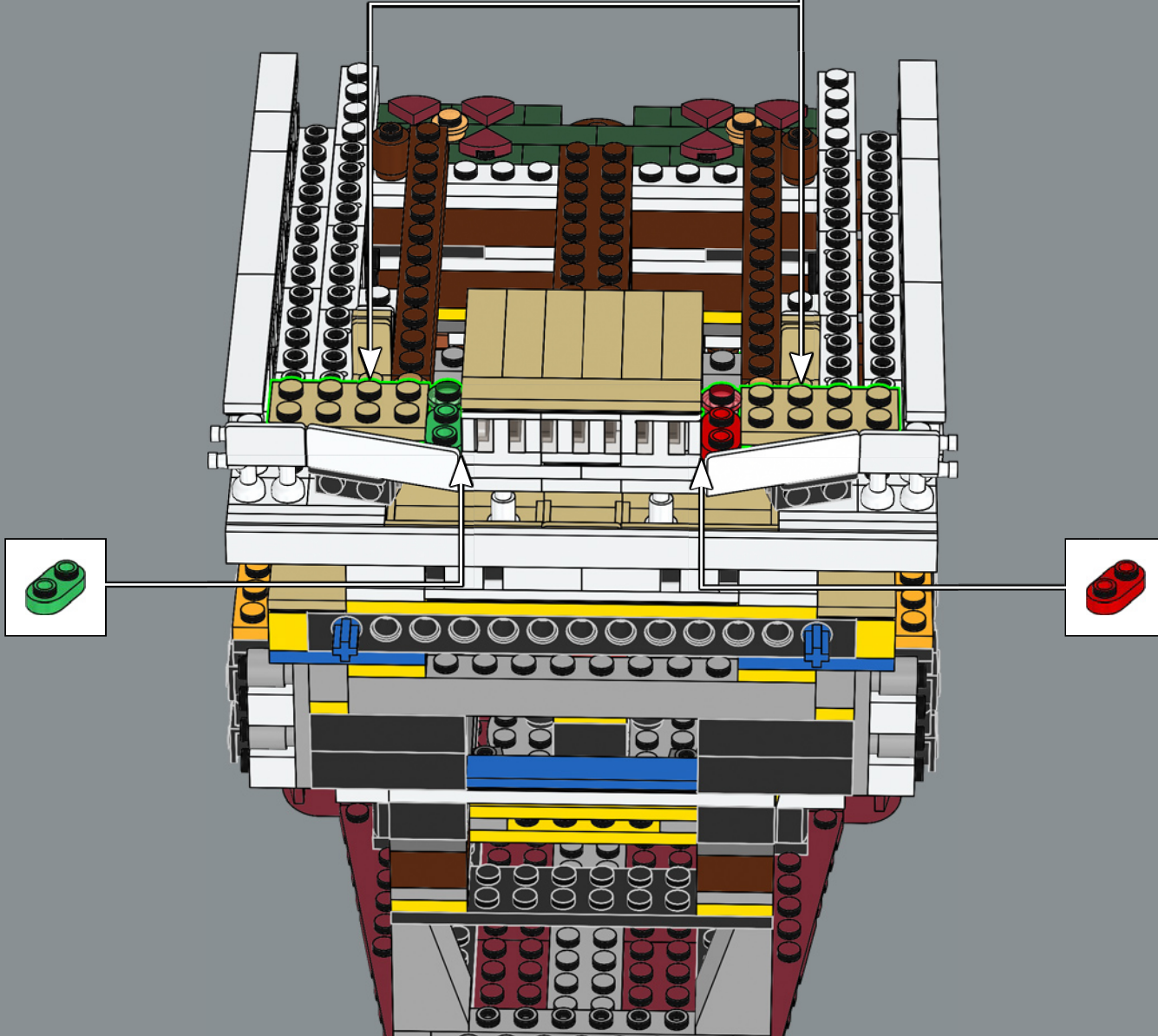
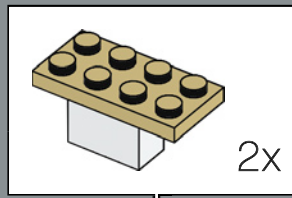

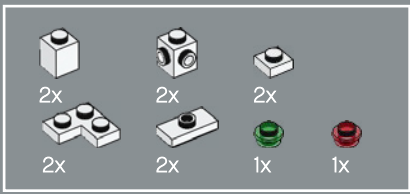

265

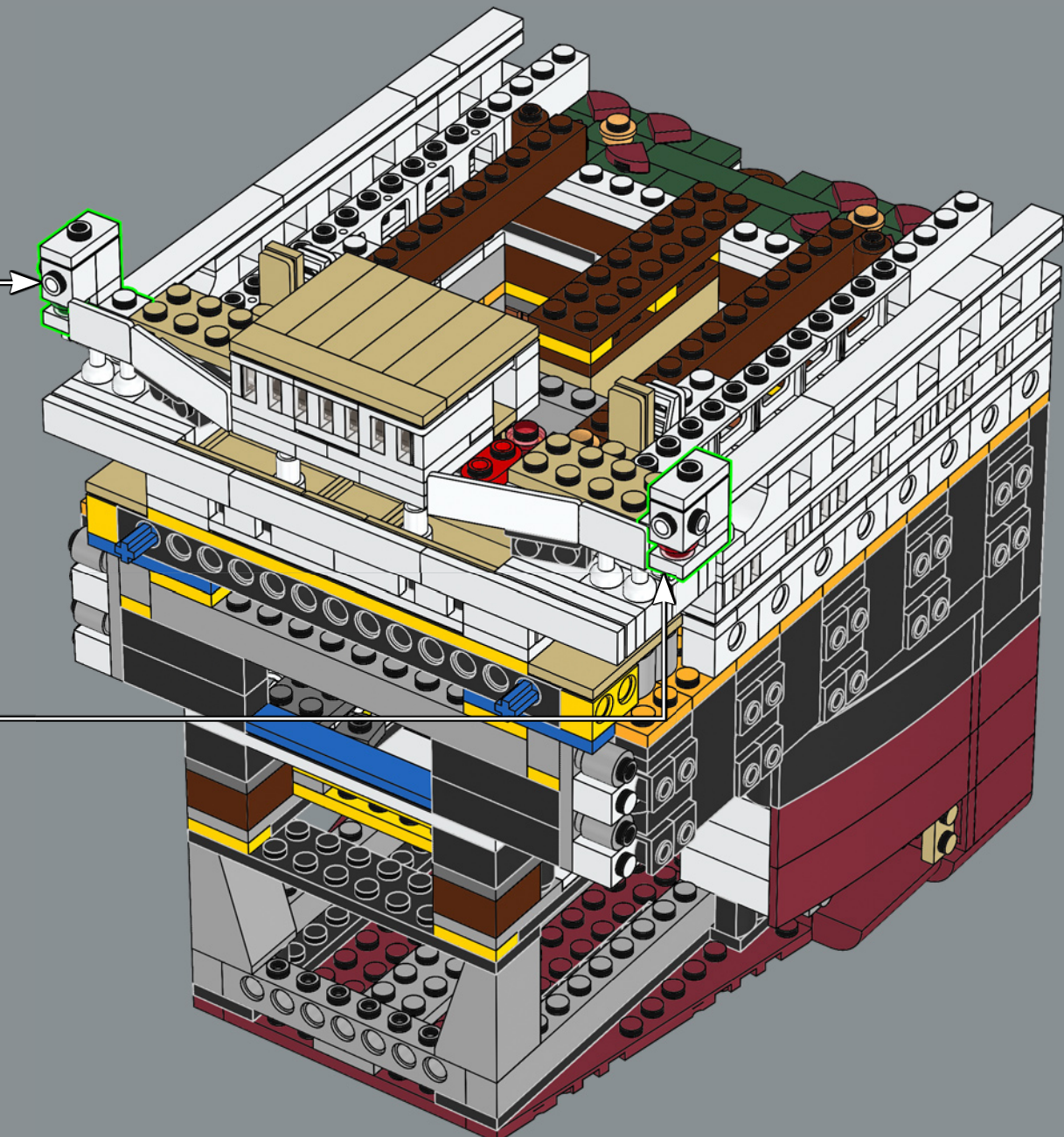
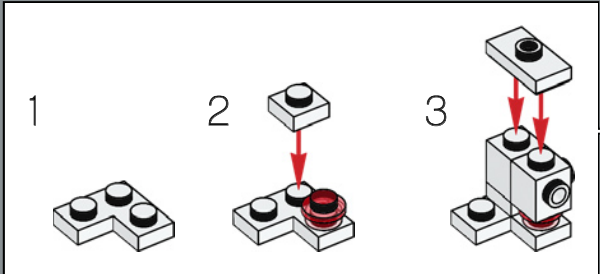
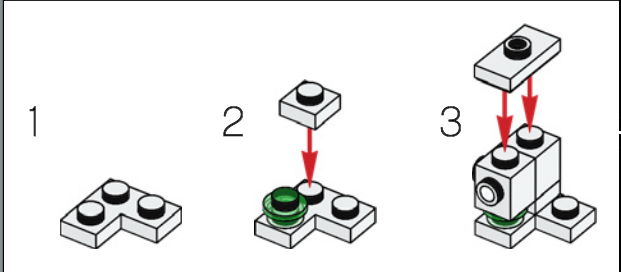



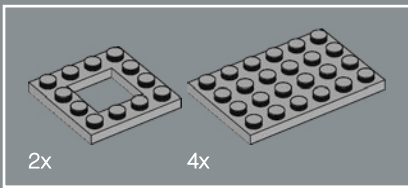

266

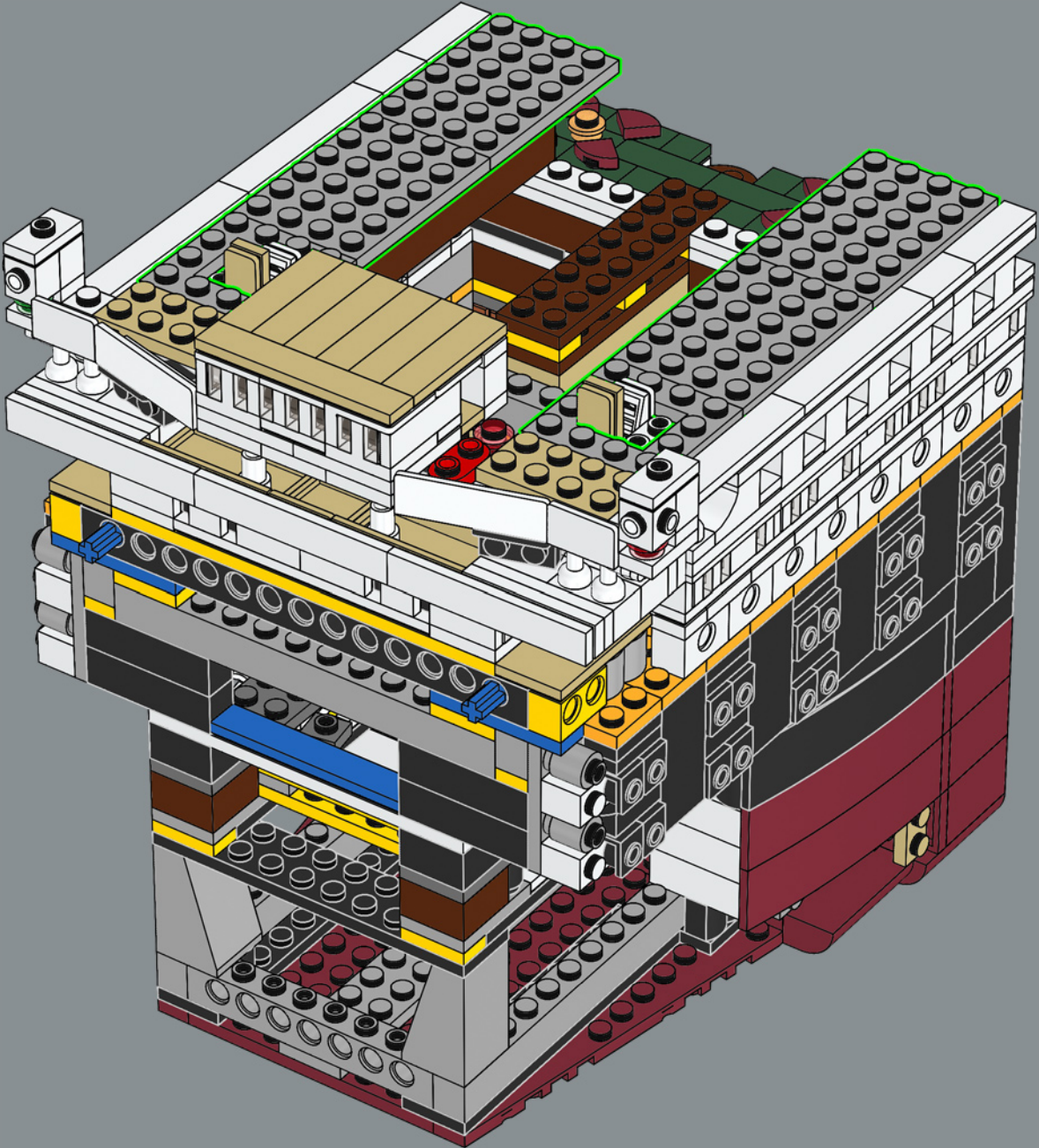

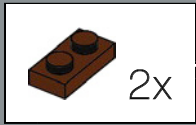
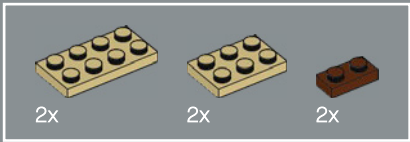

267

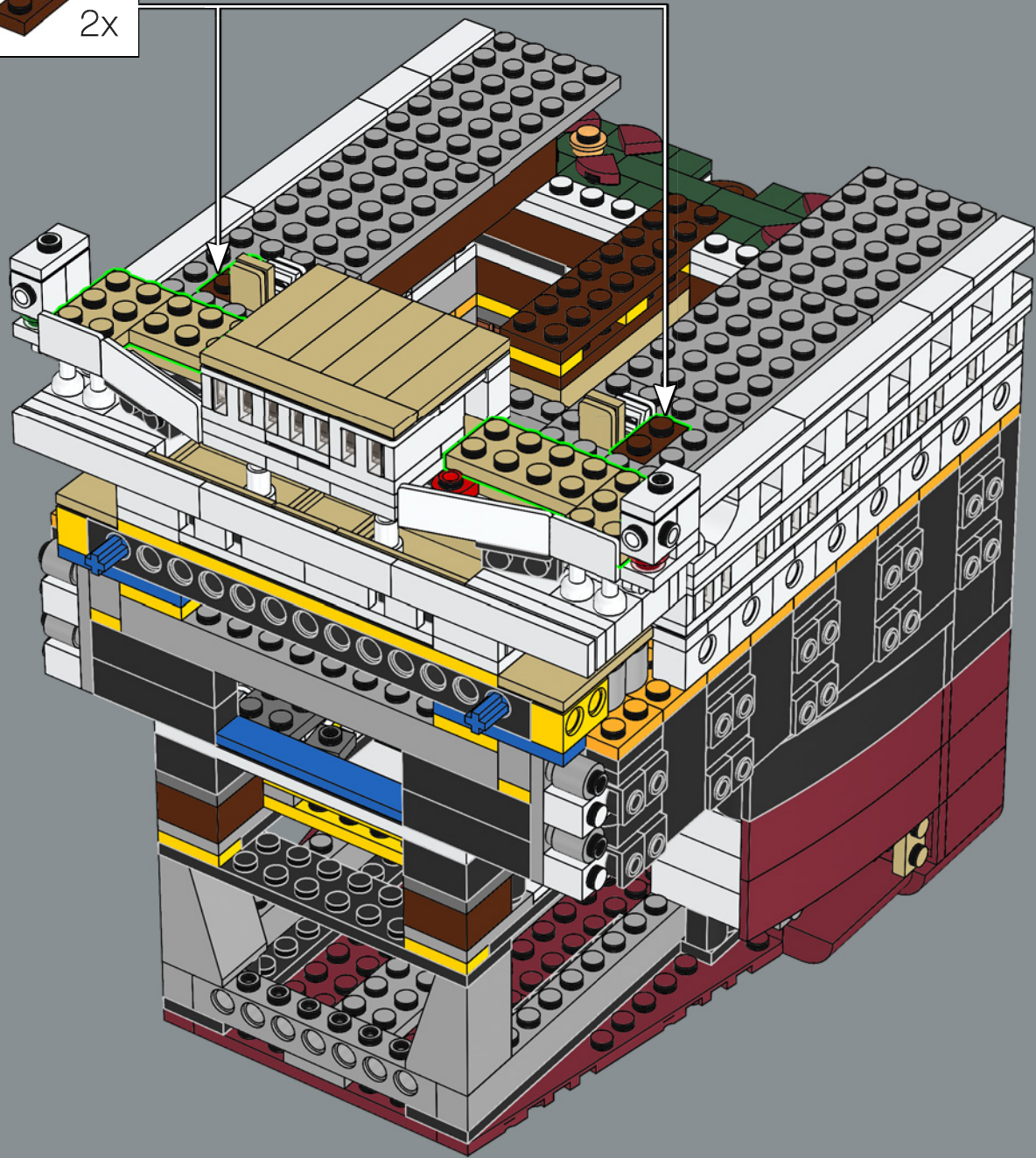

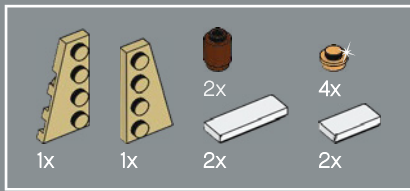

268

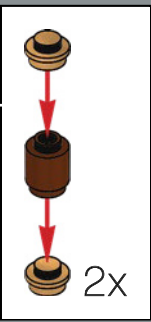
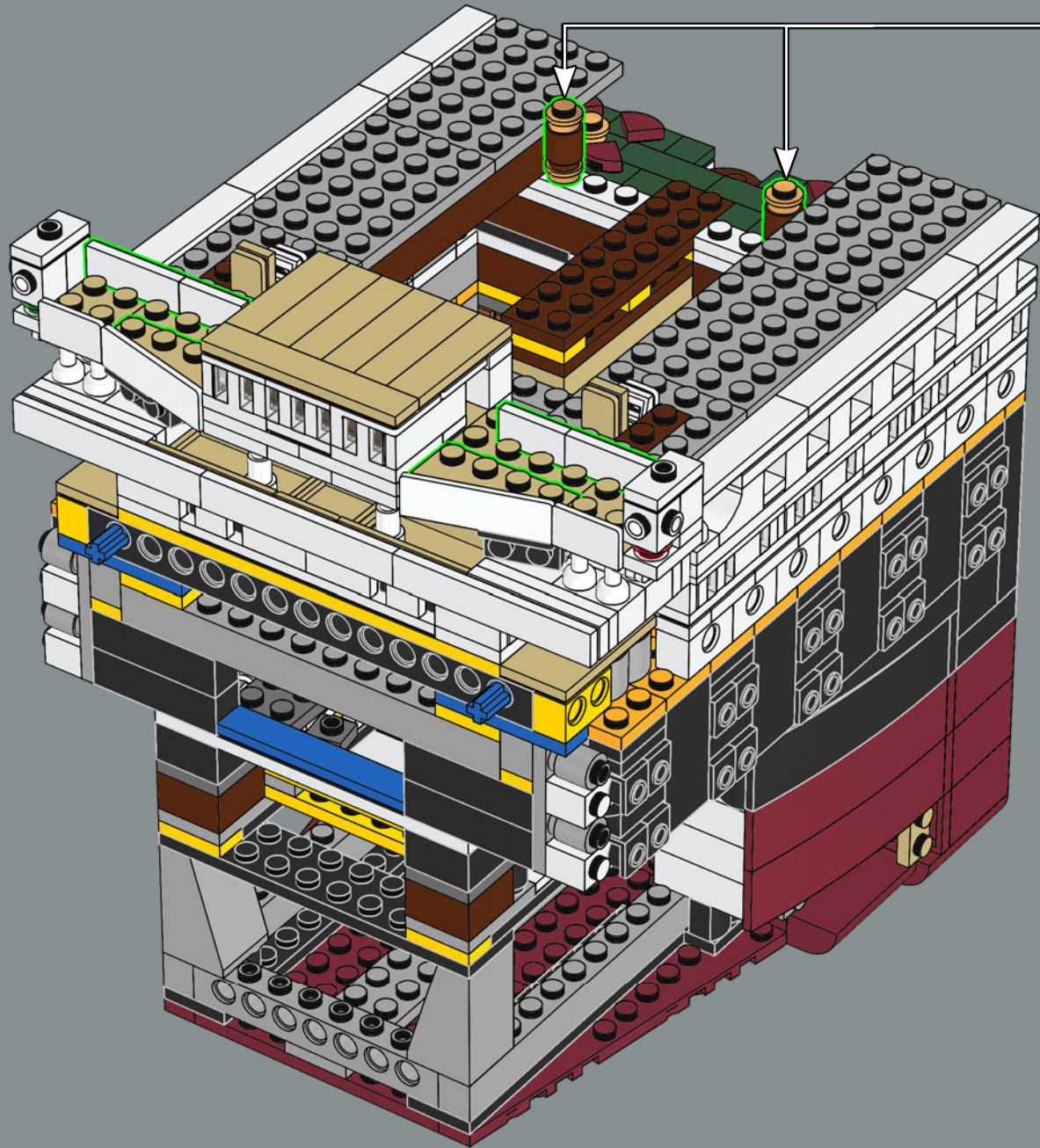
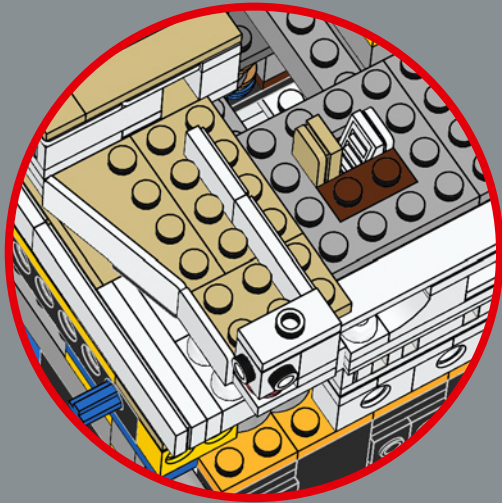
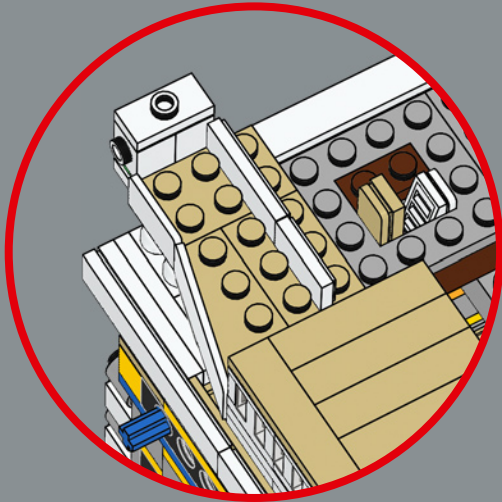

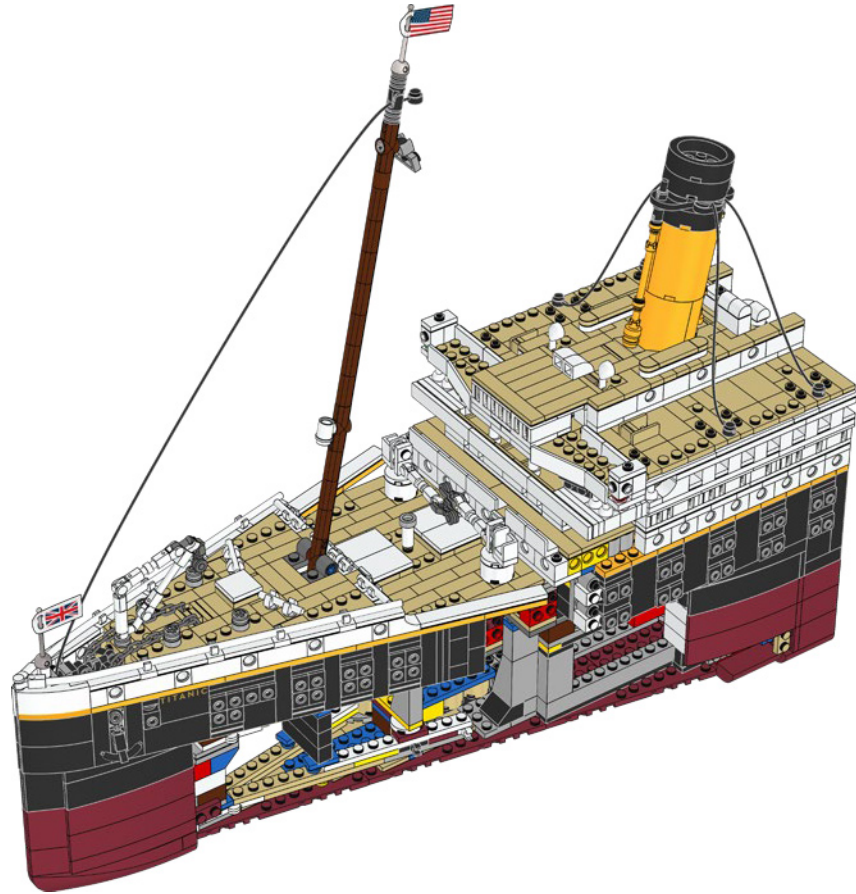

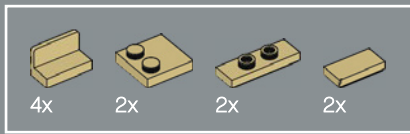

269

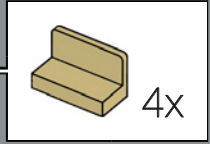
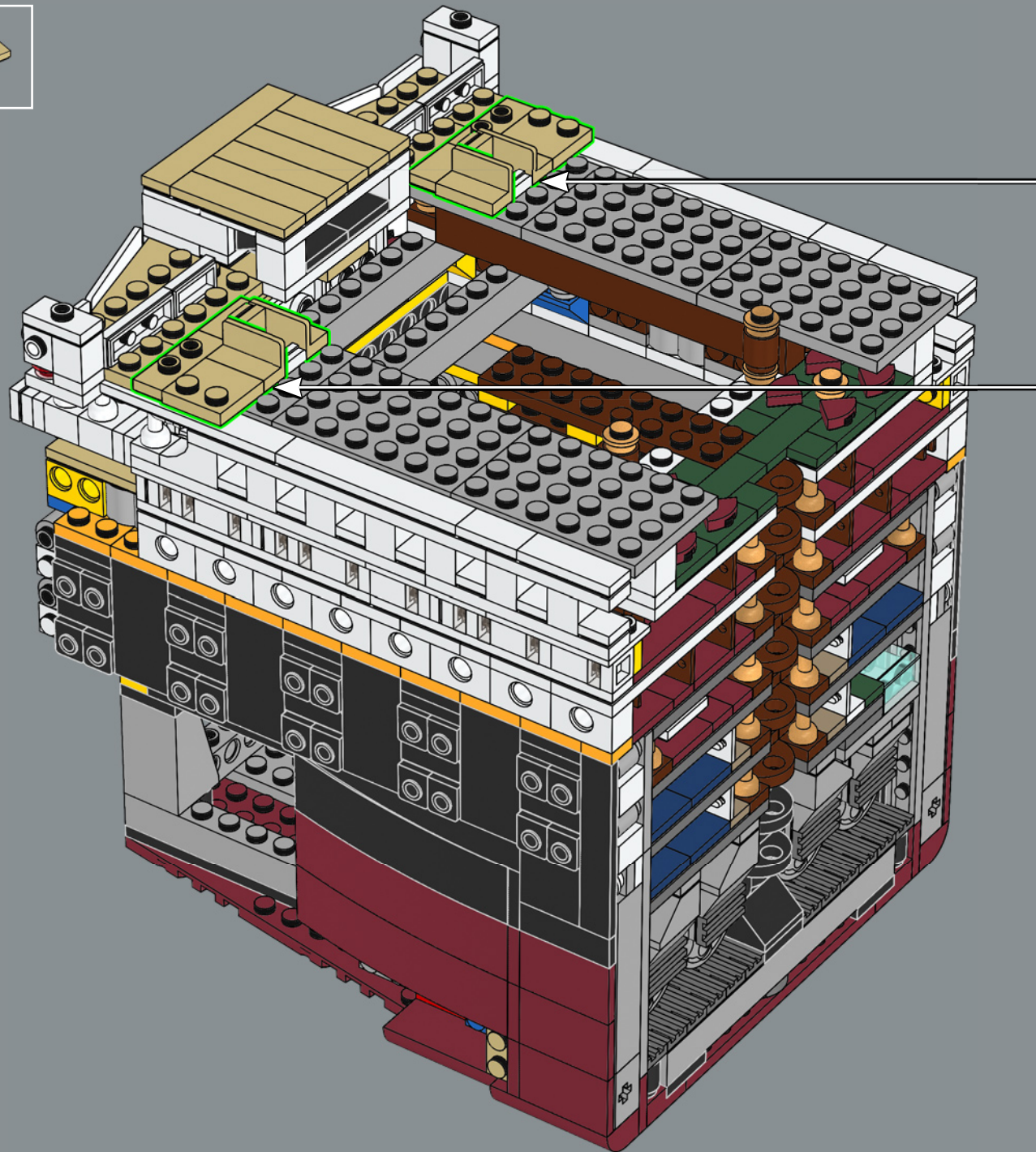

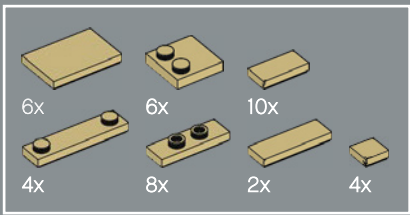

270

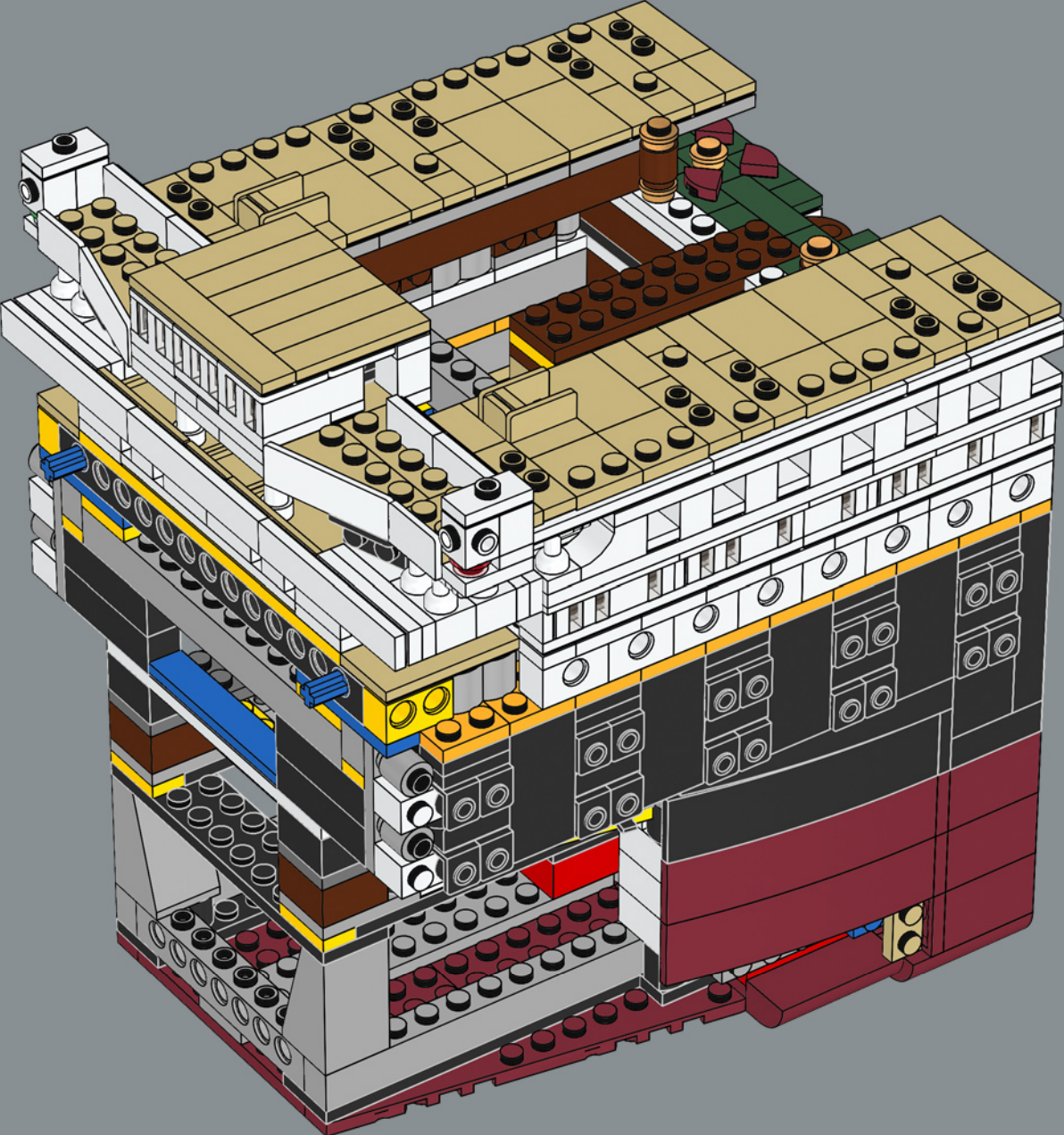



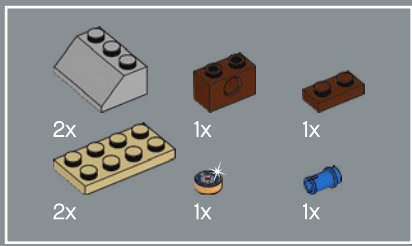

274

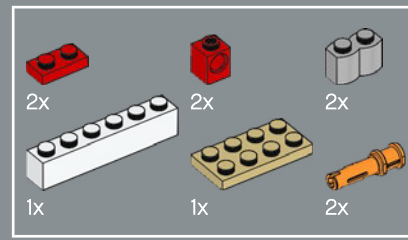
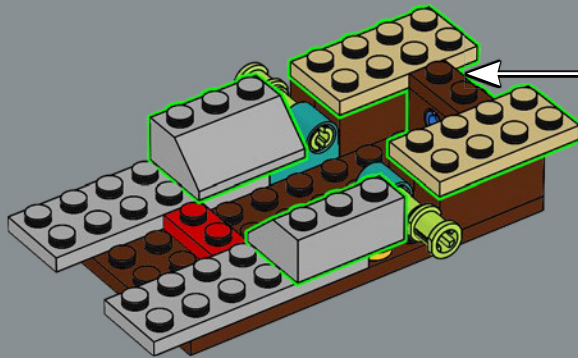
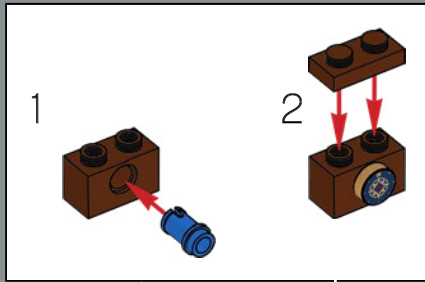

275

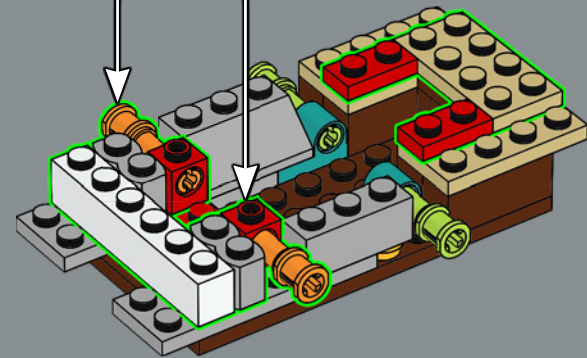
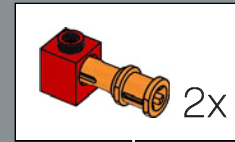



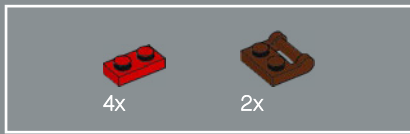

276

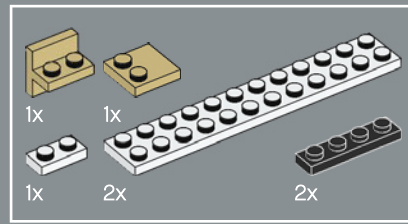
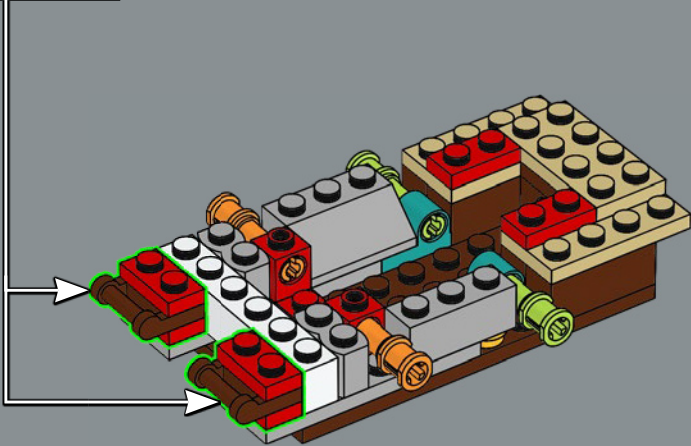
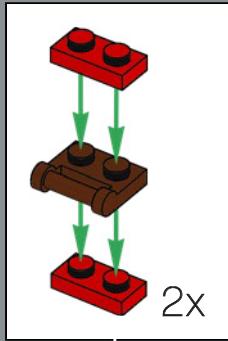

277

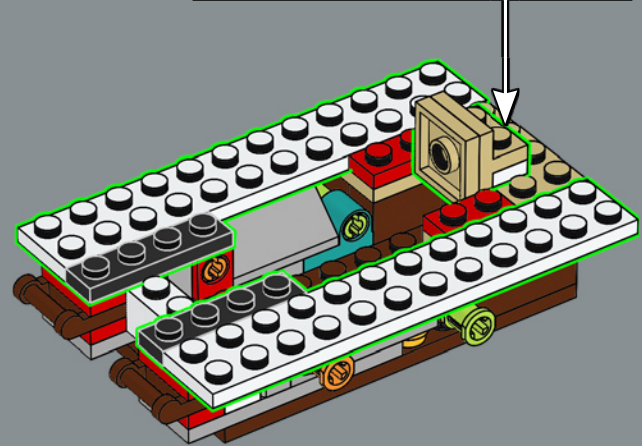
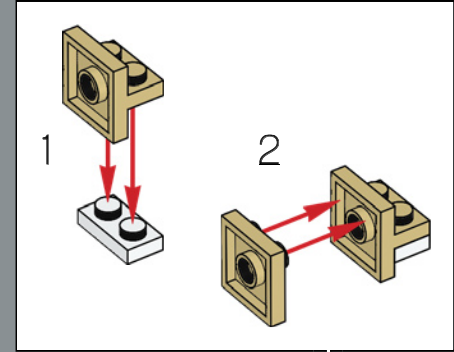

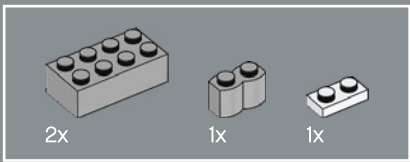

278

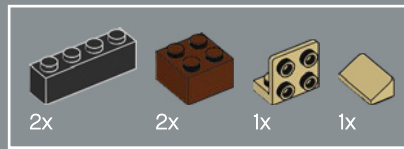
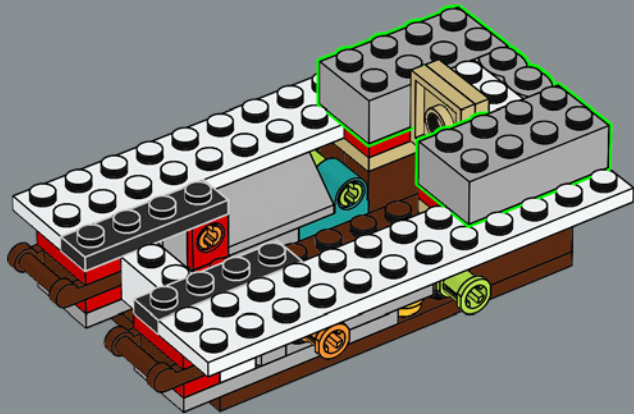

279

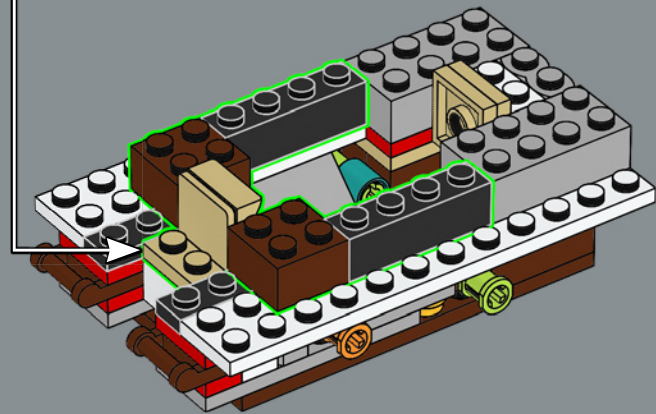
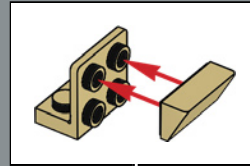

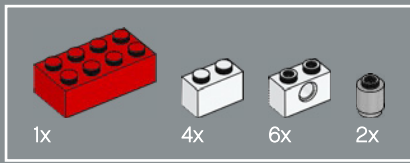

280

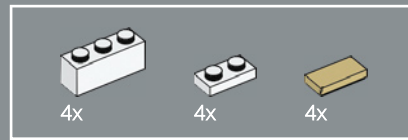
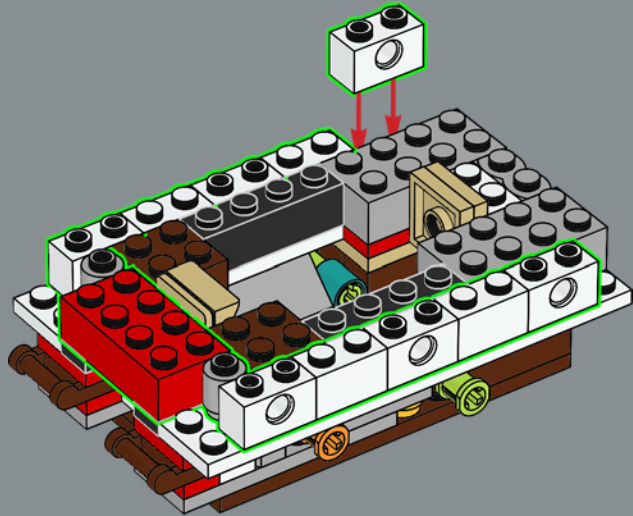

281

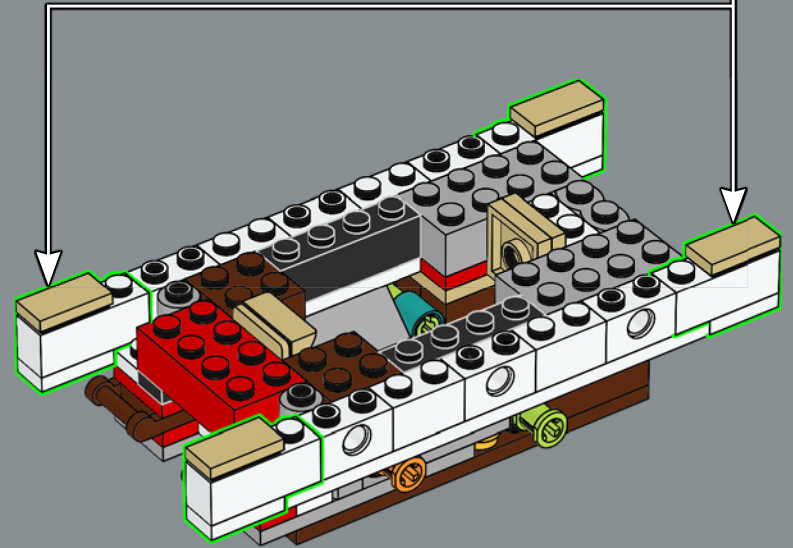
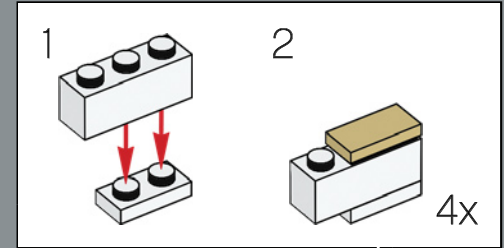

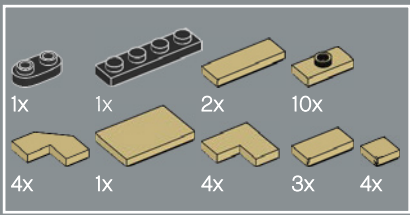

282

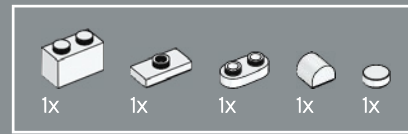
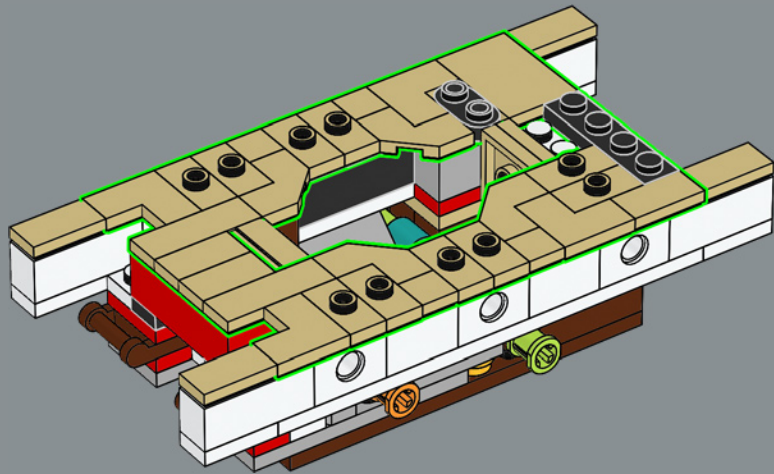

283

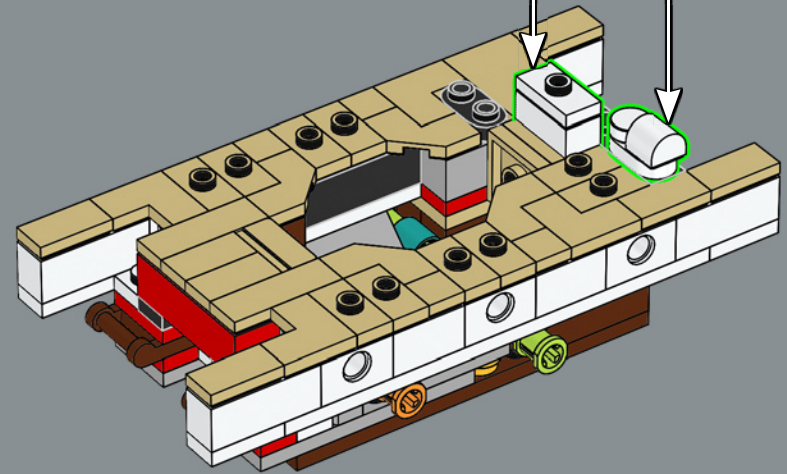
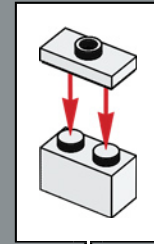
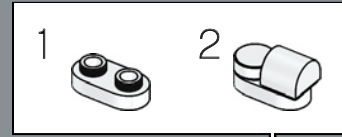

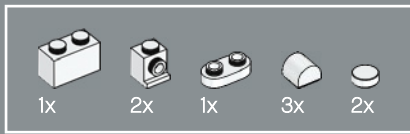

284

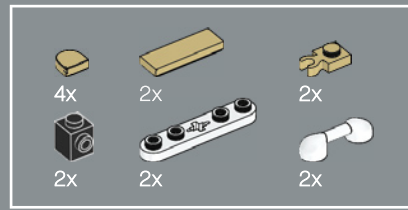
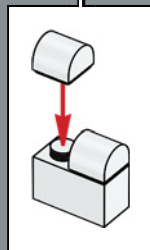
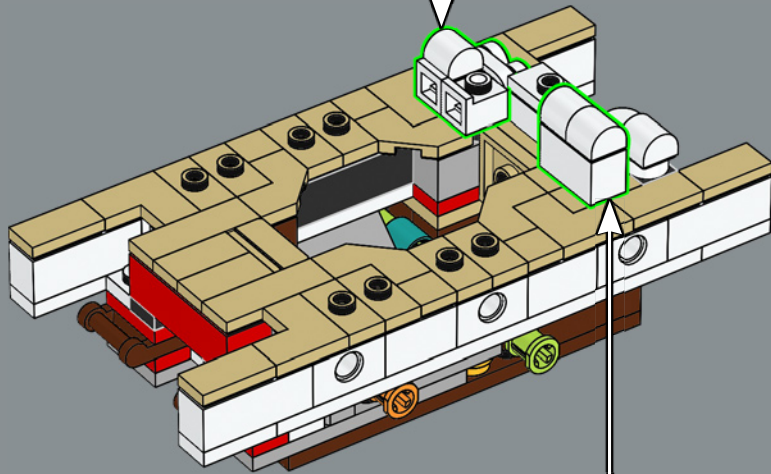
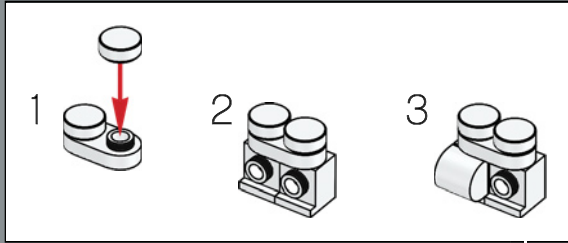

285

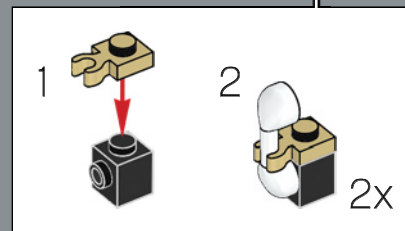
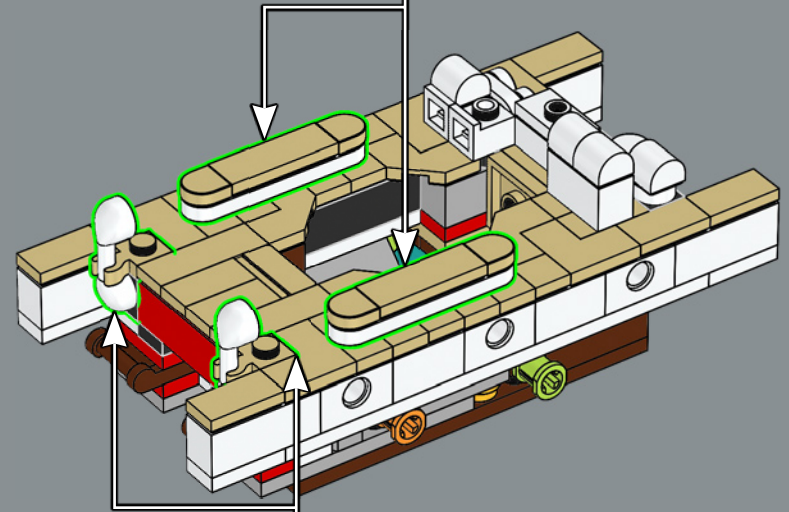
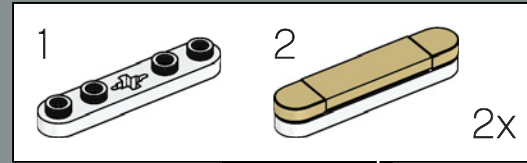

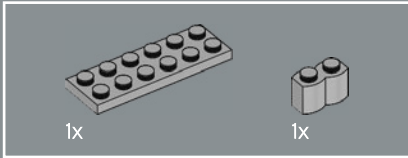
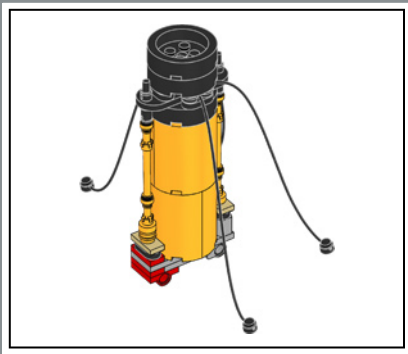

286

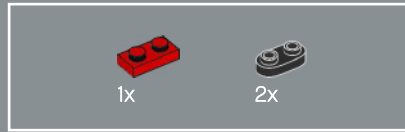
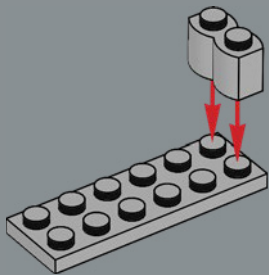

287

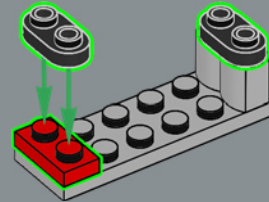

288

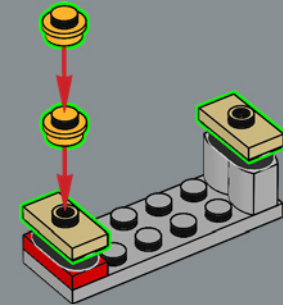

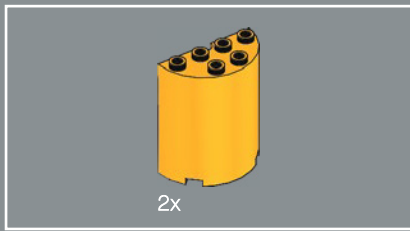

289

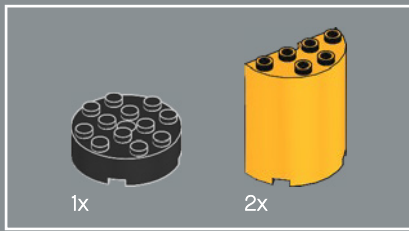
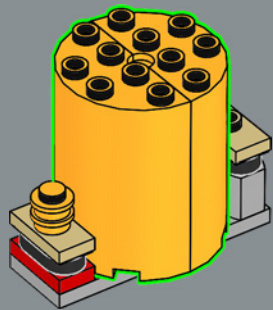

290

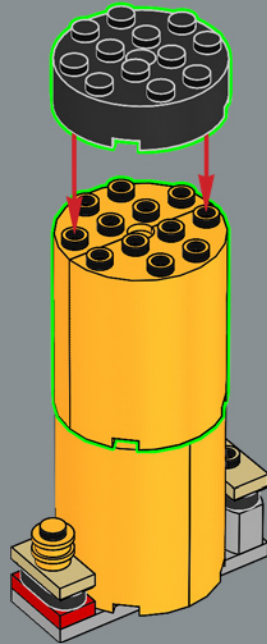

291

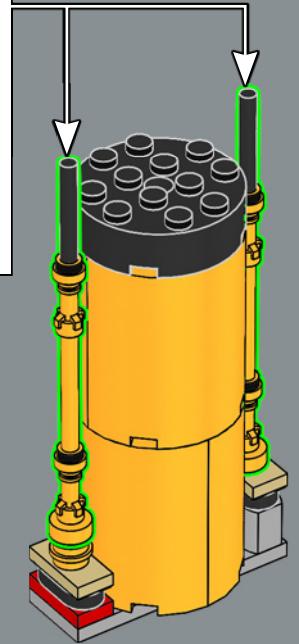
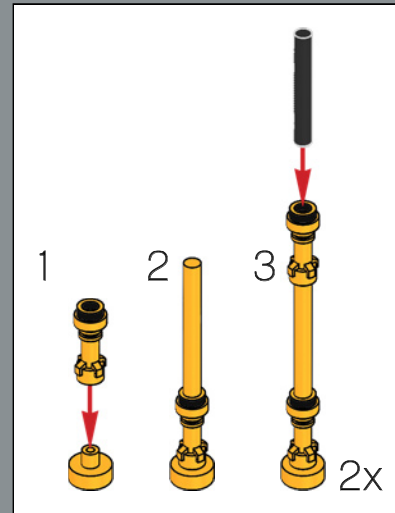

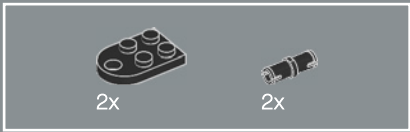

292

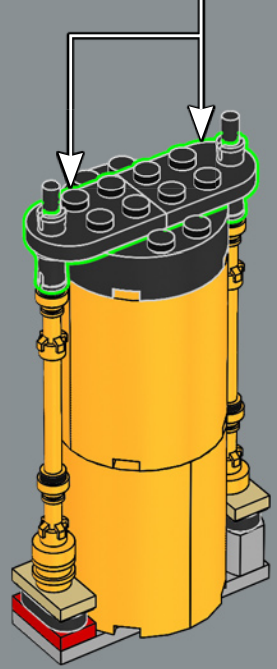
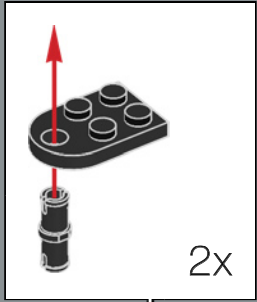

293

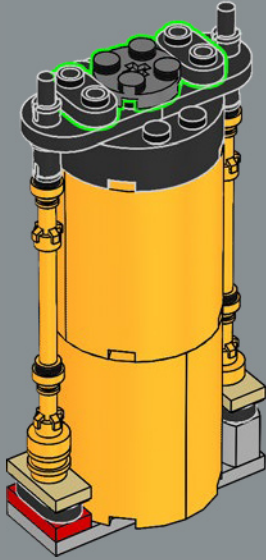



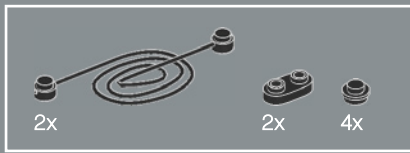

294

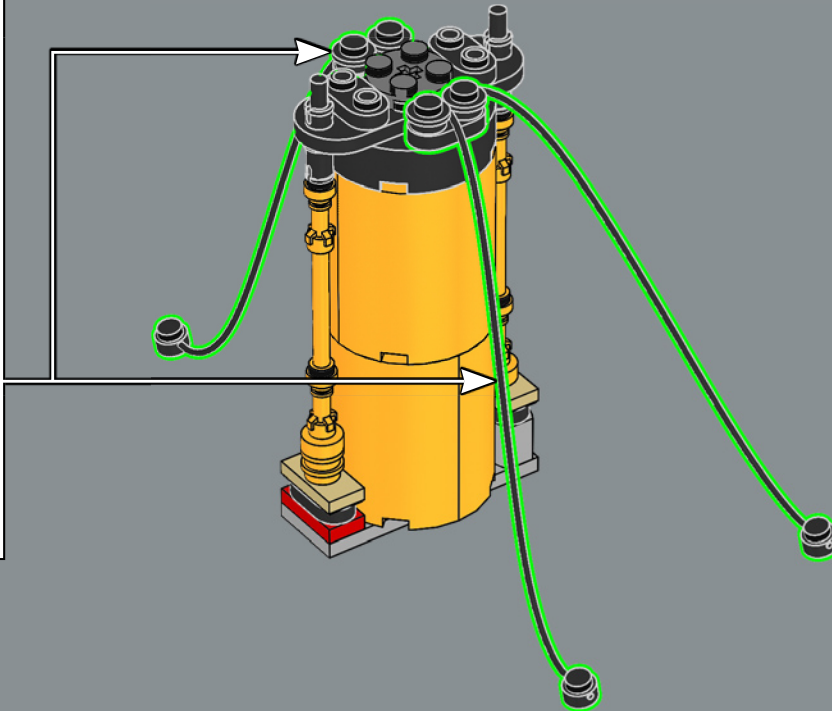
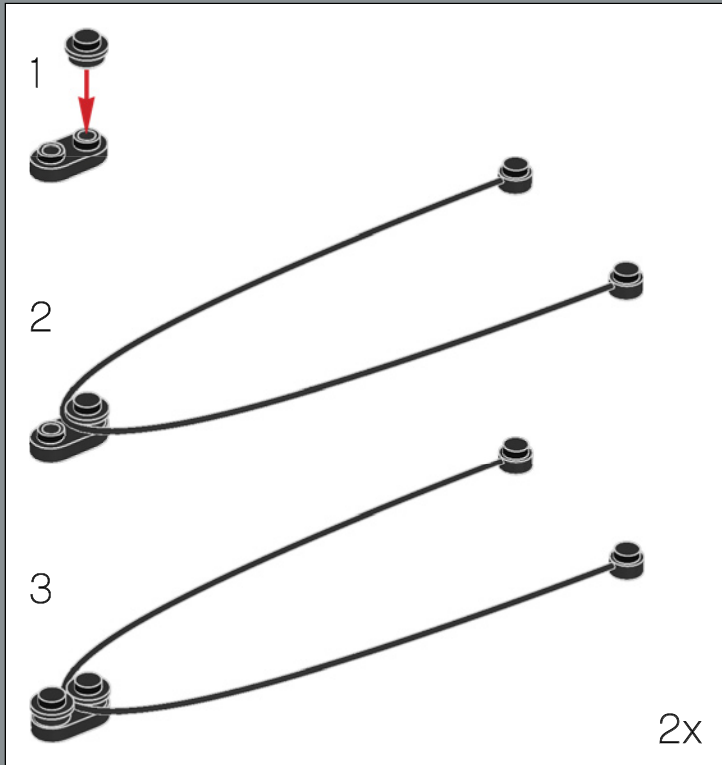

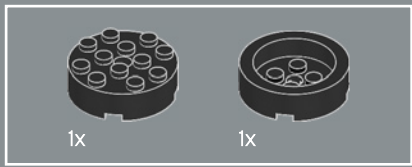

295

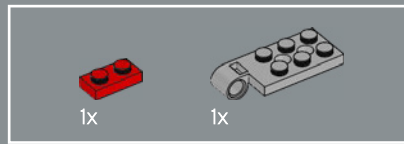
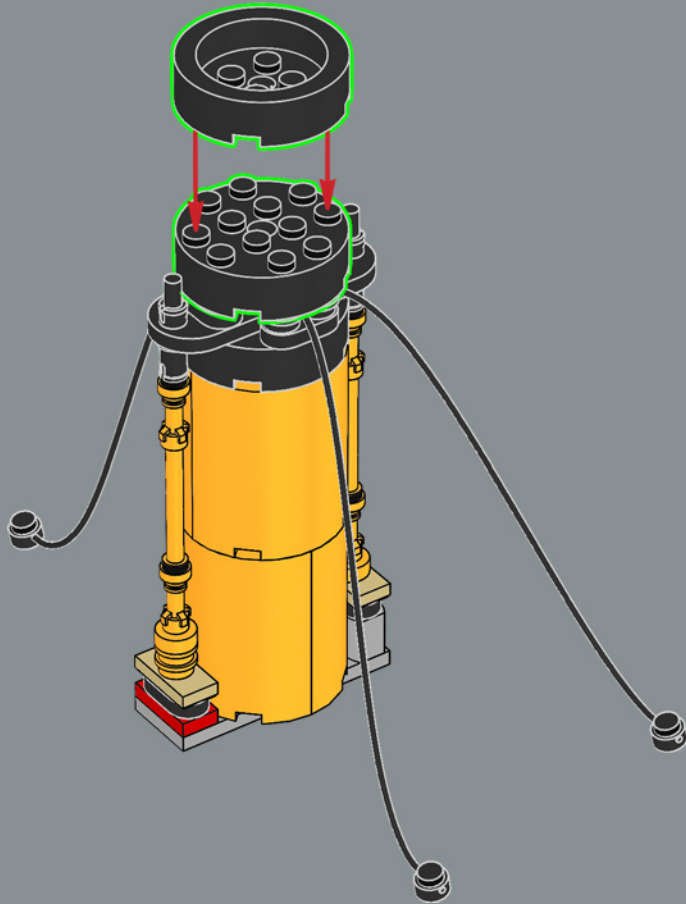

296

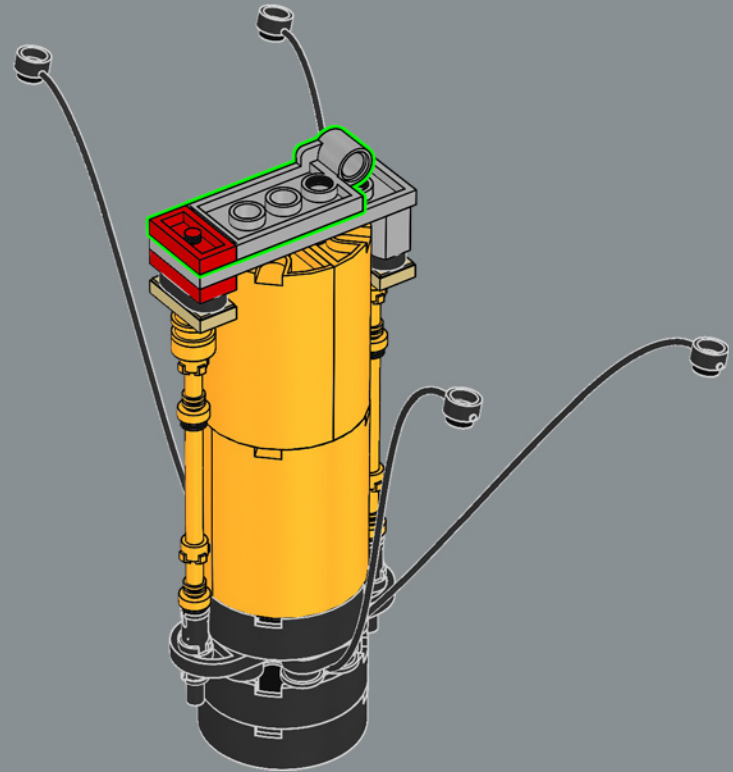

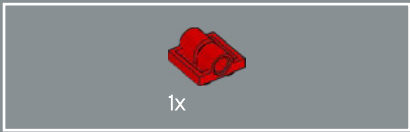

297

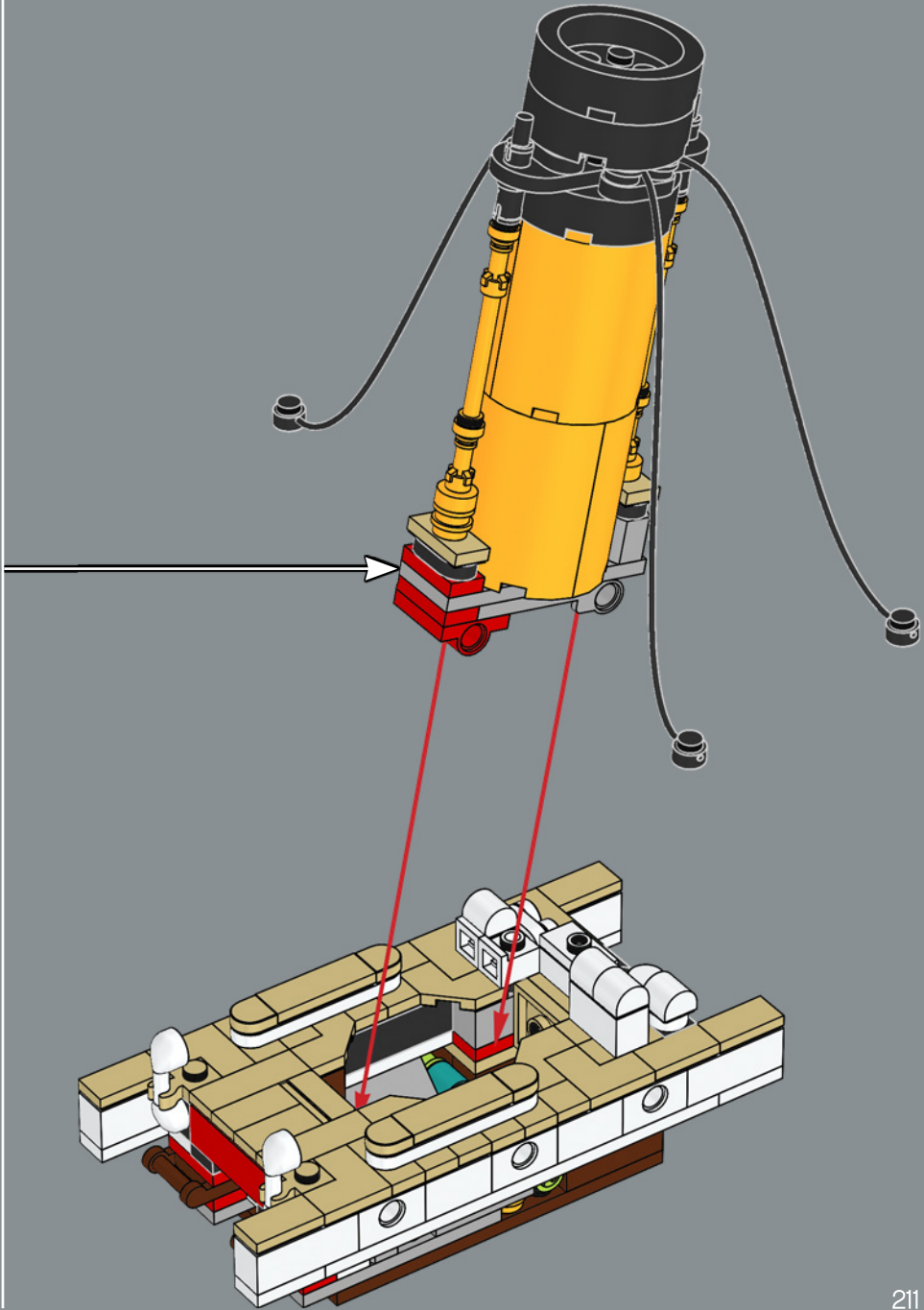
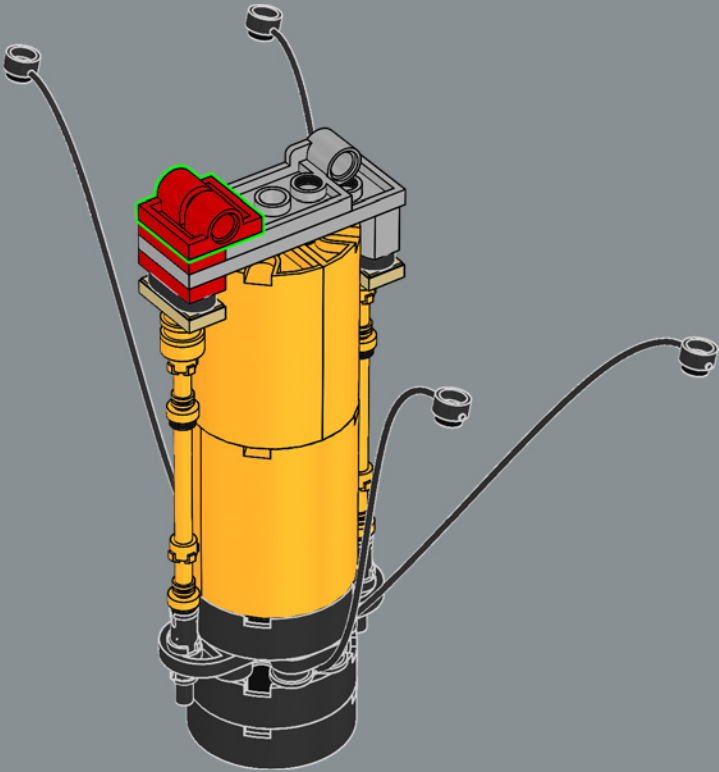

La salle de communication du navire contient l'un des plus puissants émetteurs au monde, permettant d'émettre un signal sur un rayon de 563 km.

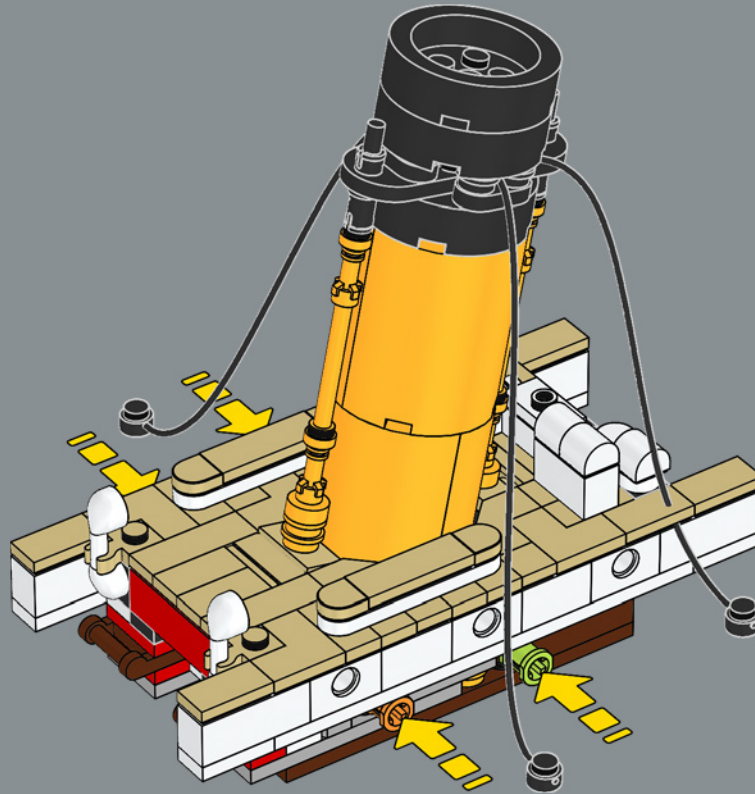

299

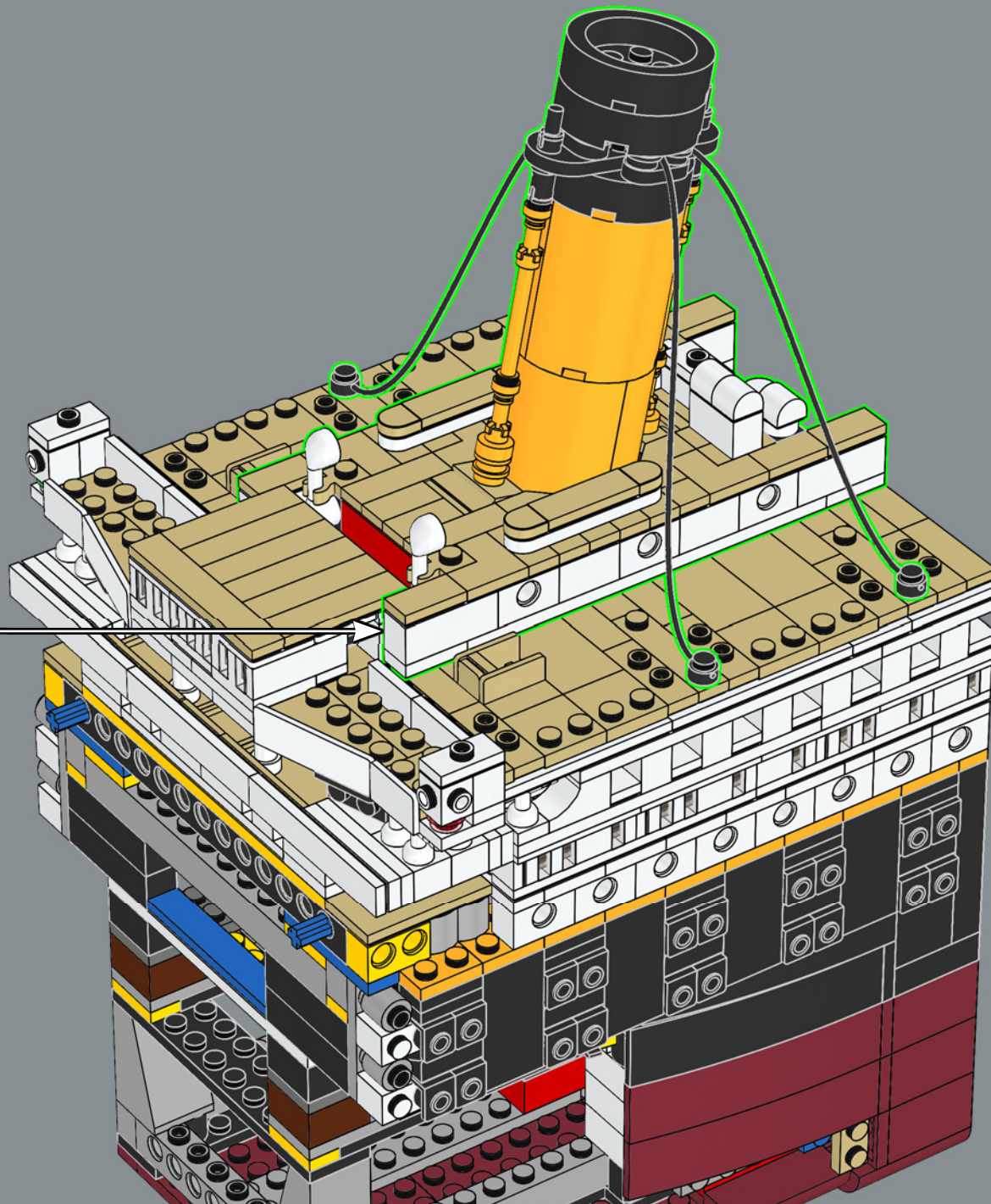

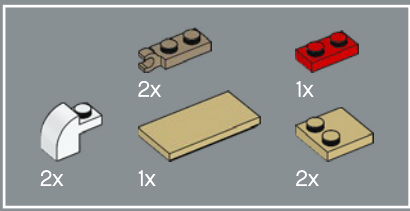

300

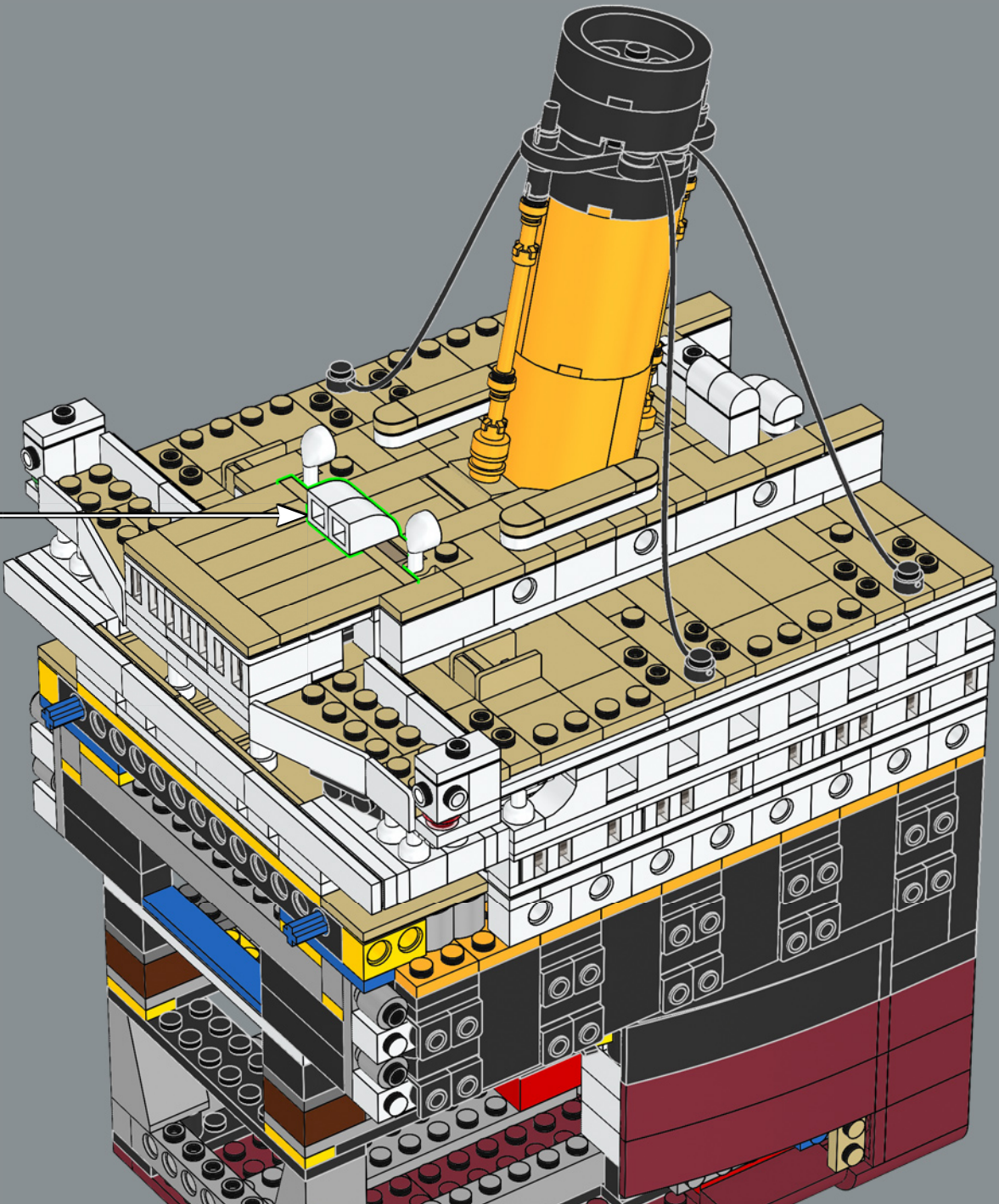
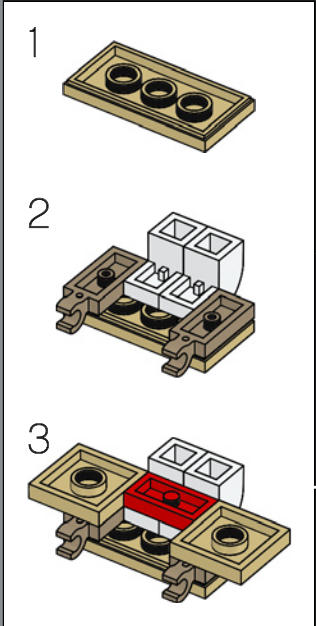

301

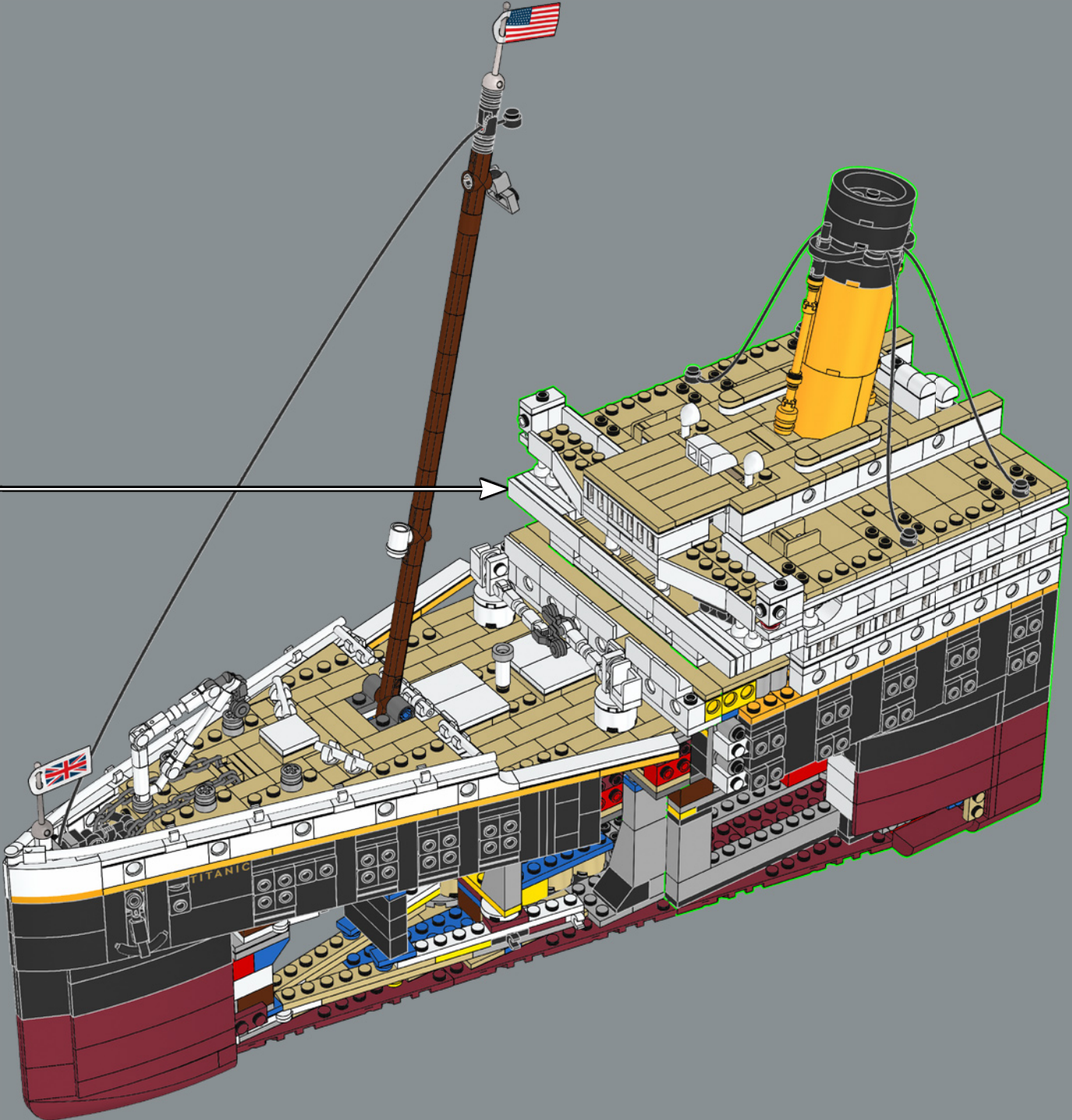

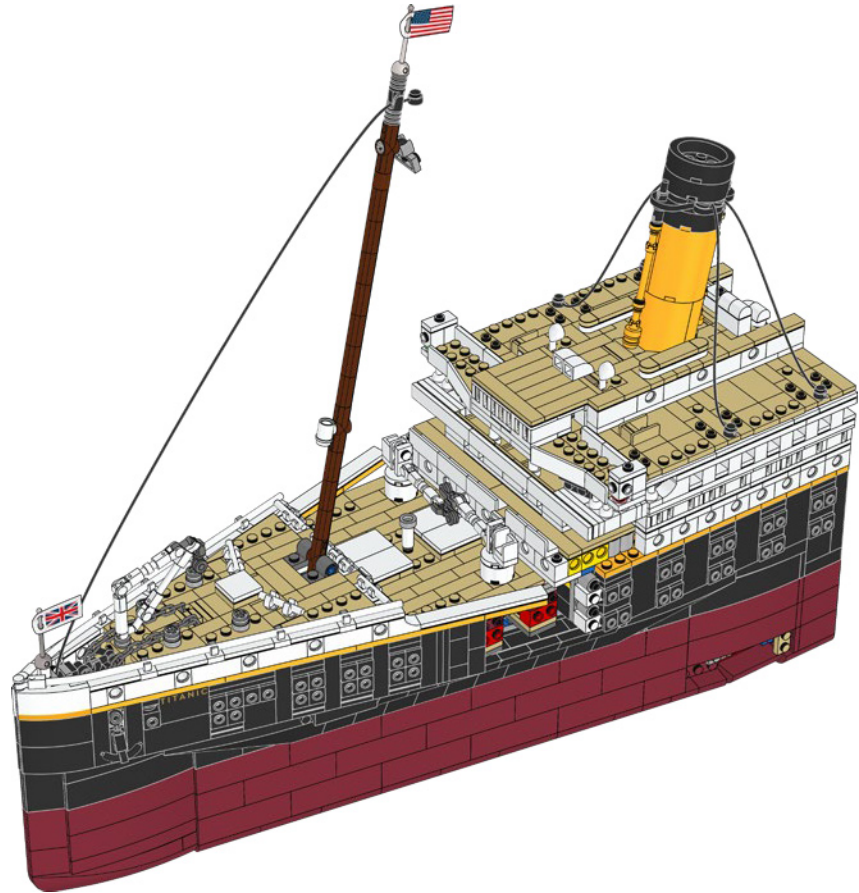
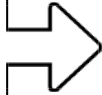



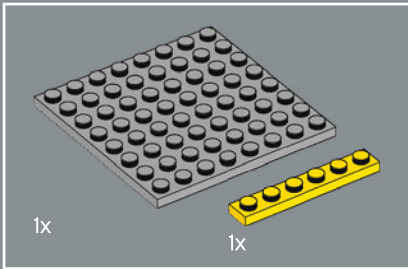
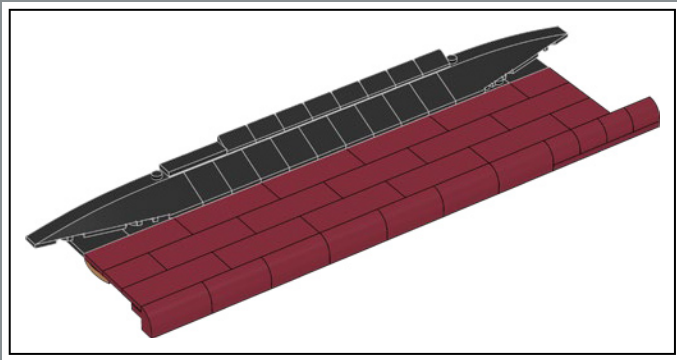

302

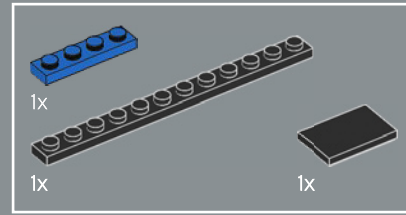
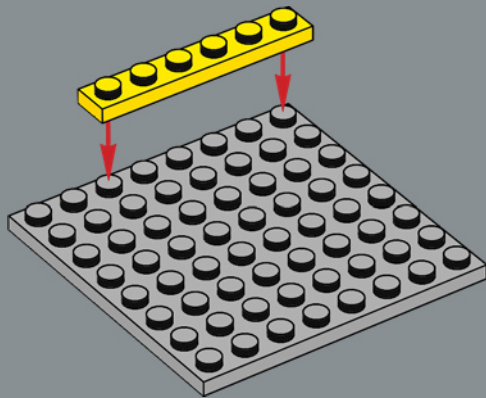

303

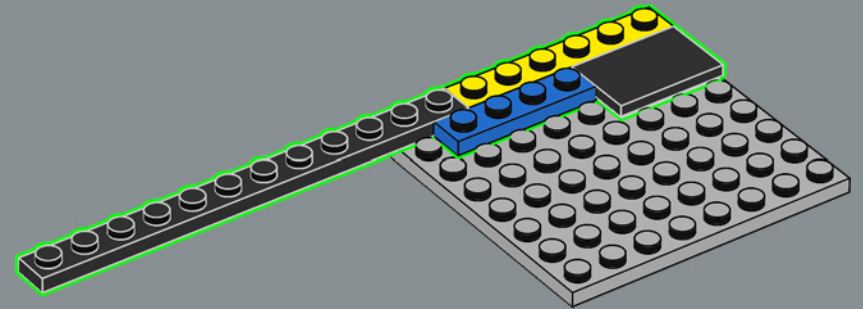

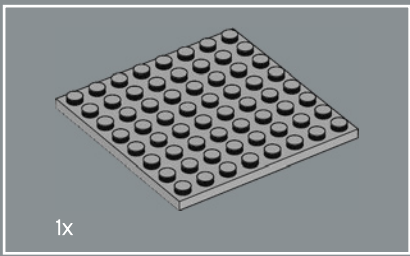

304

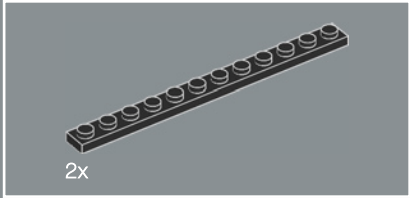
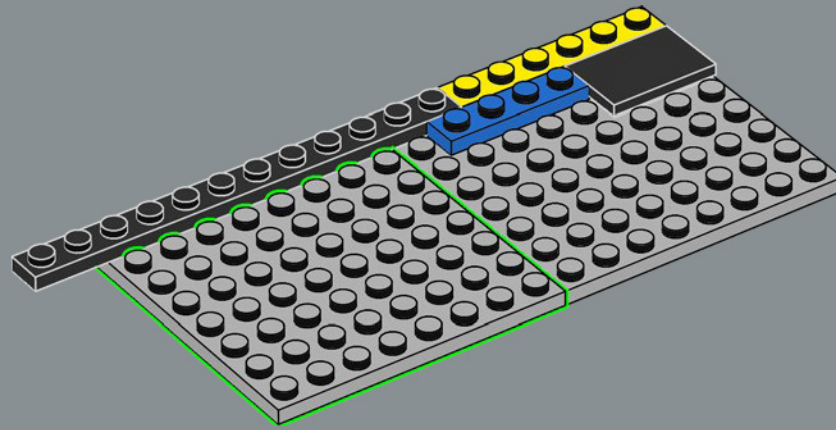

305

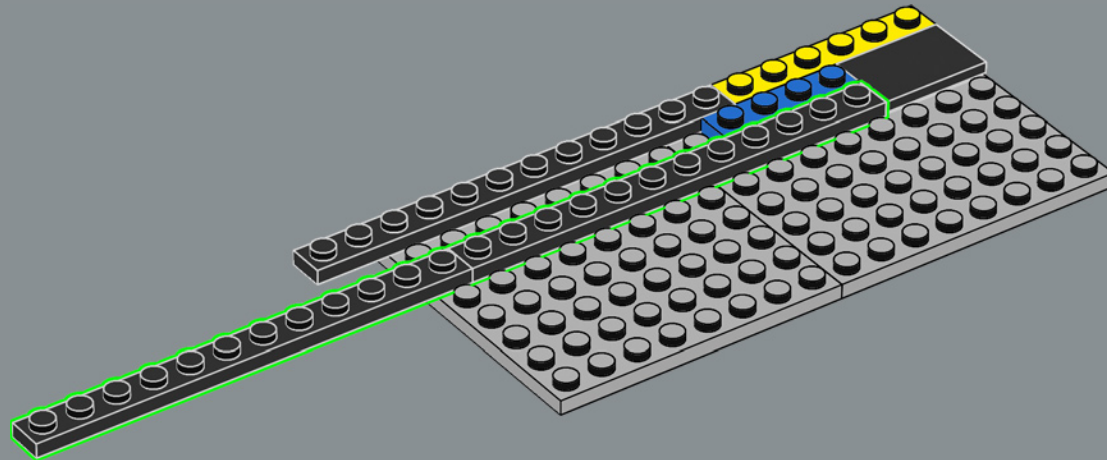

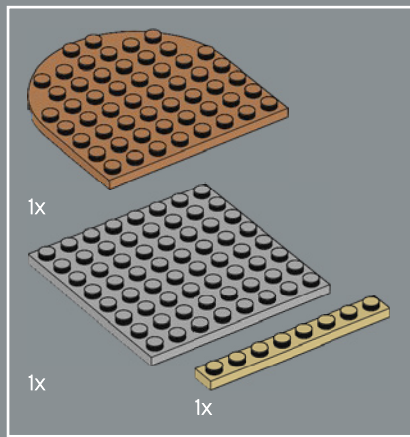

306

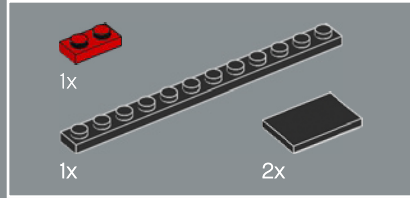
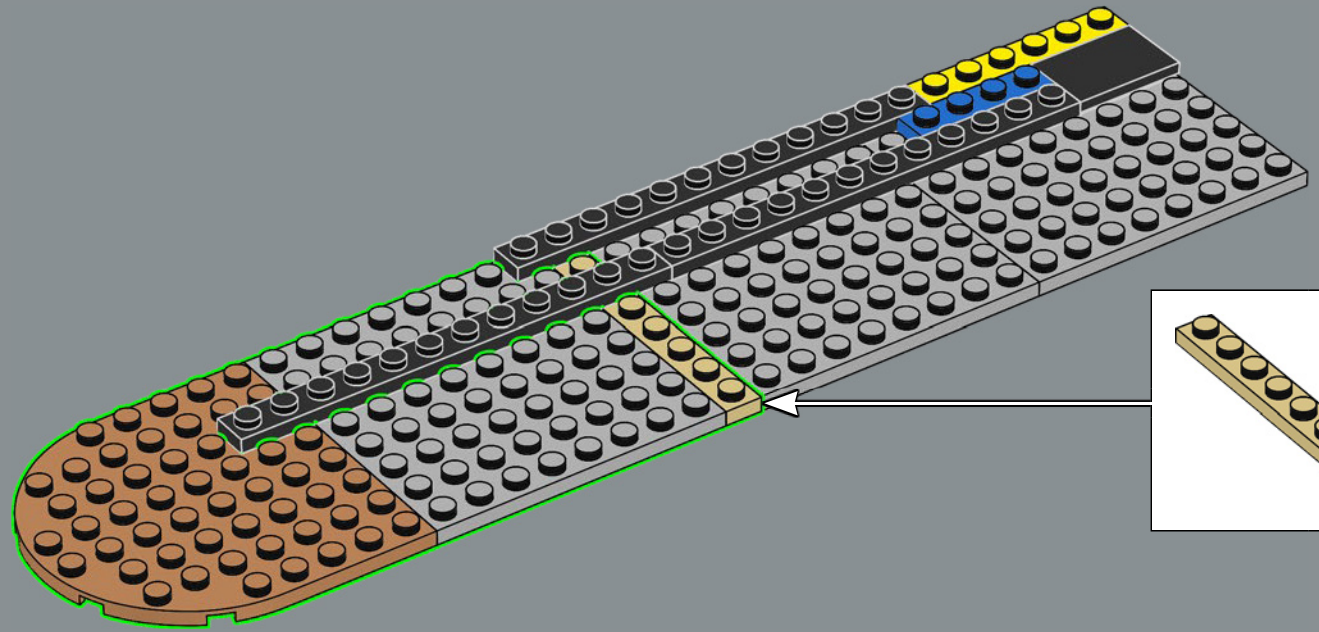

307

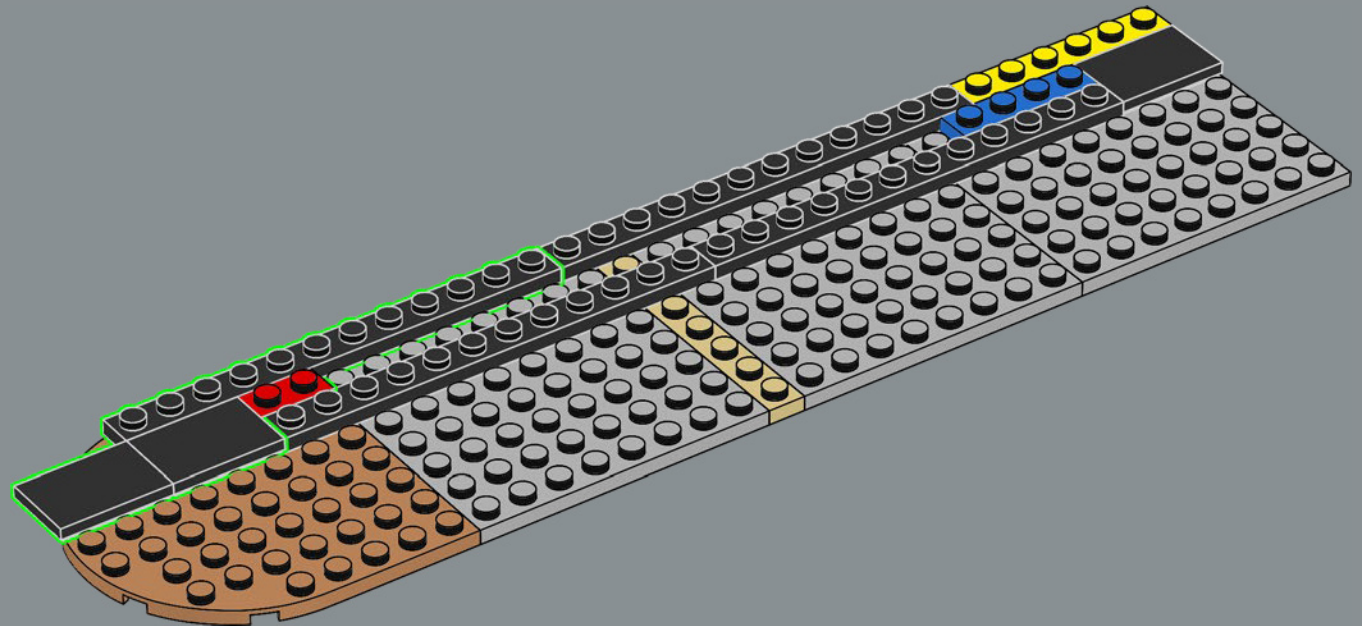

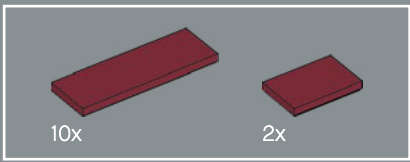

308

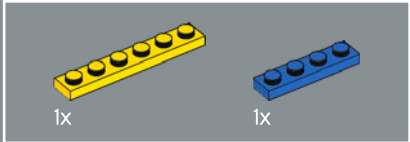
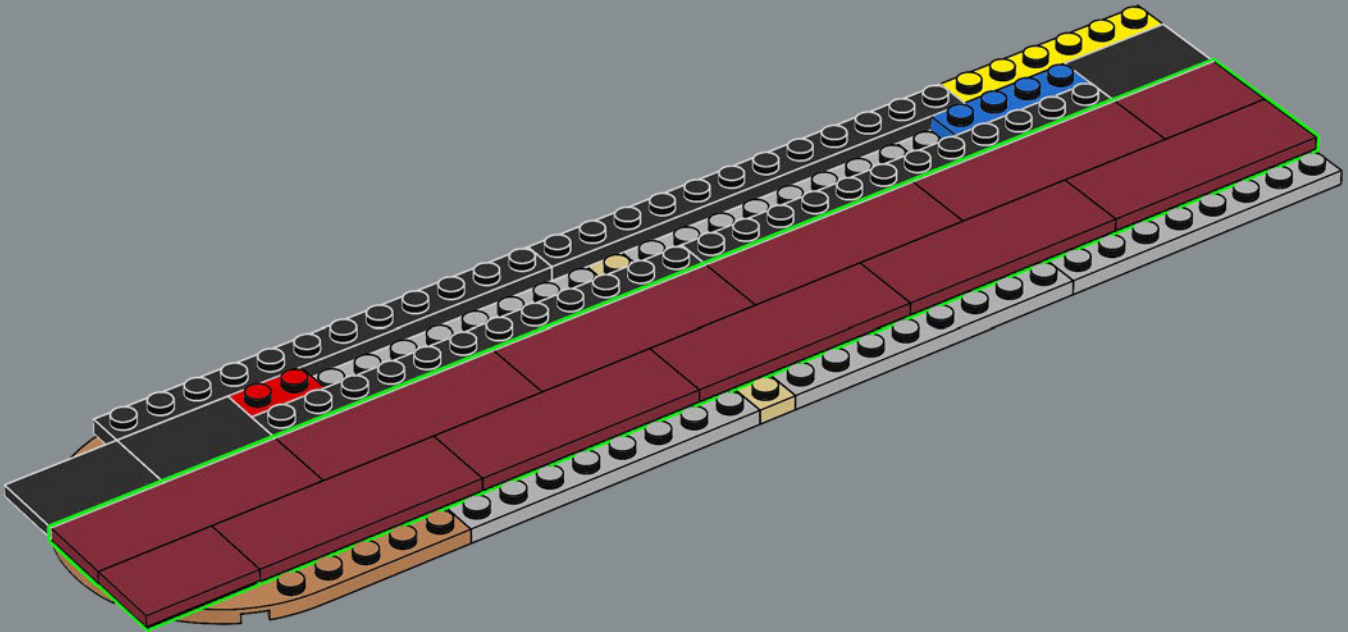

309

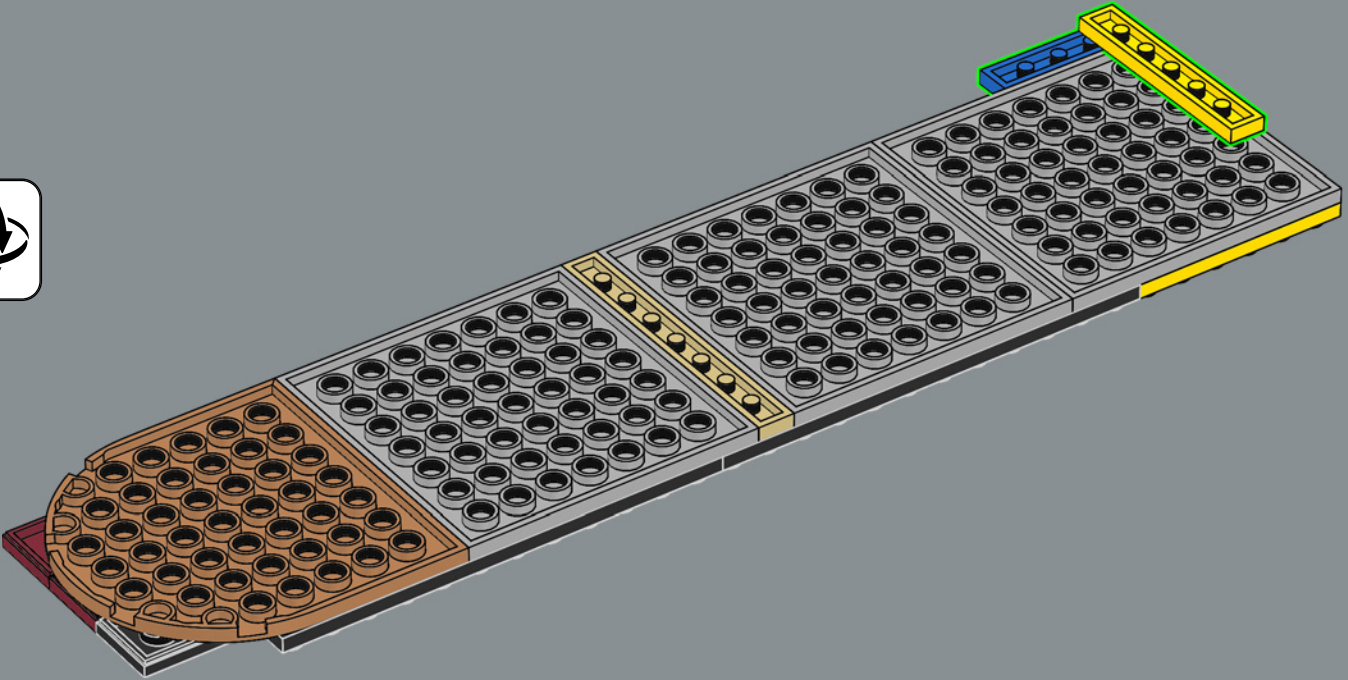

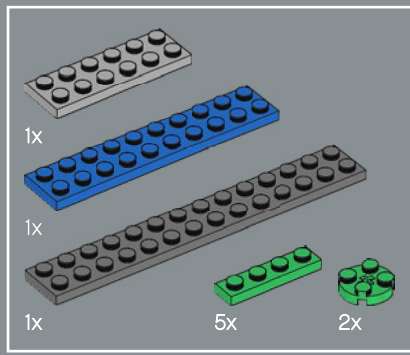

310

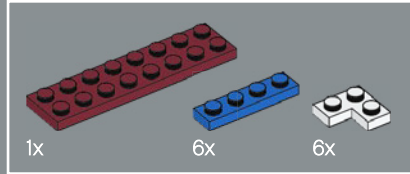
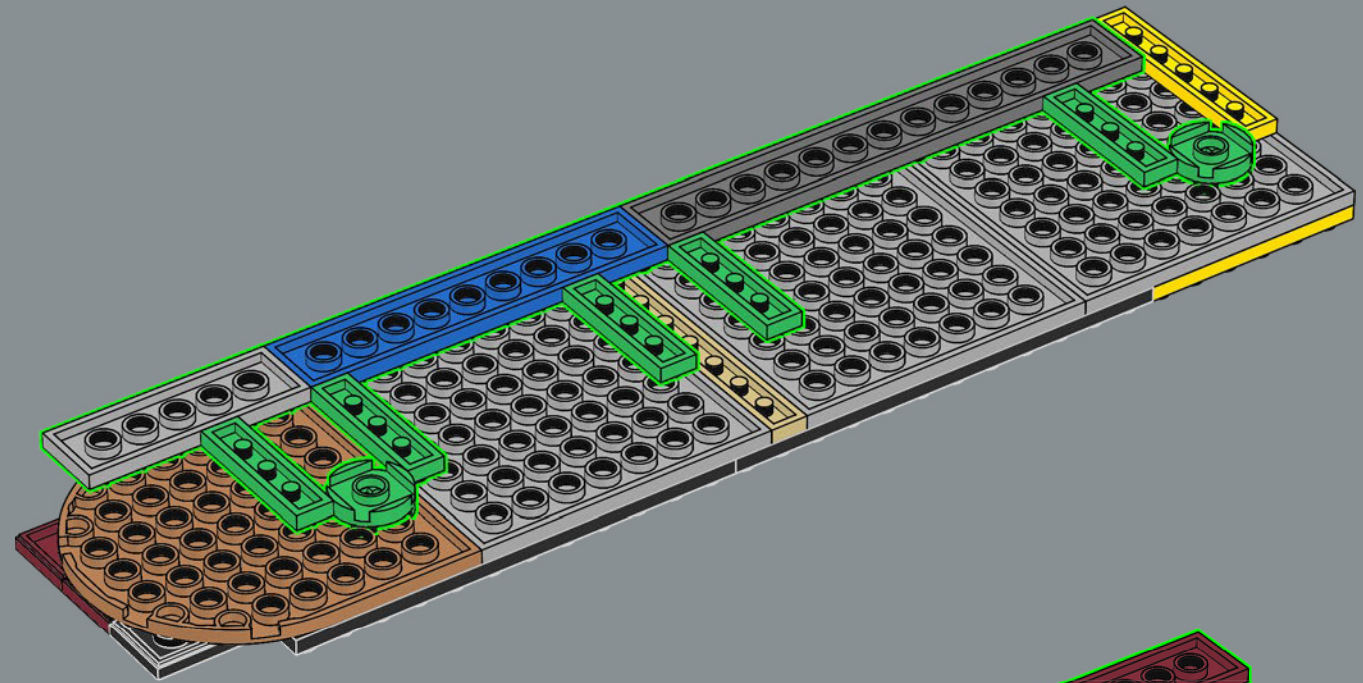

311

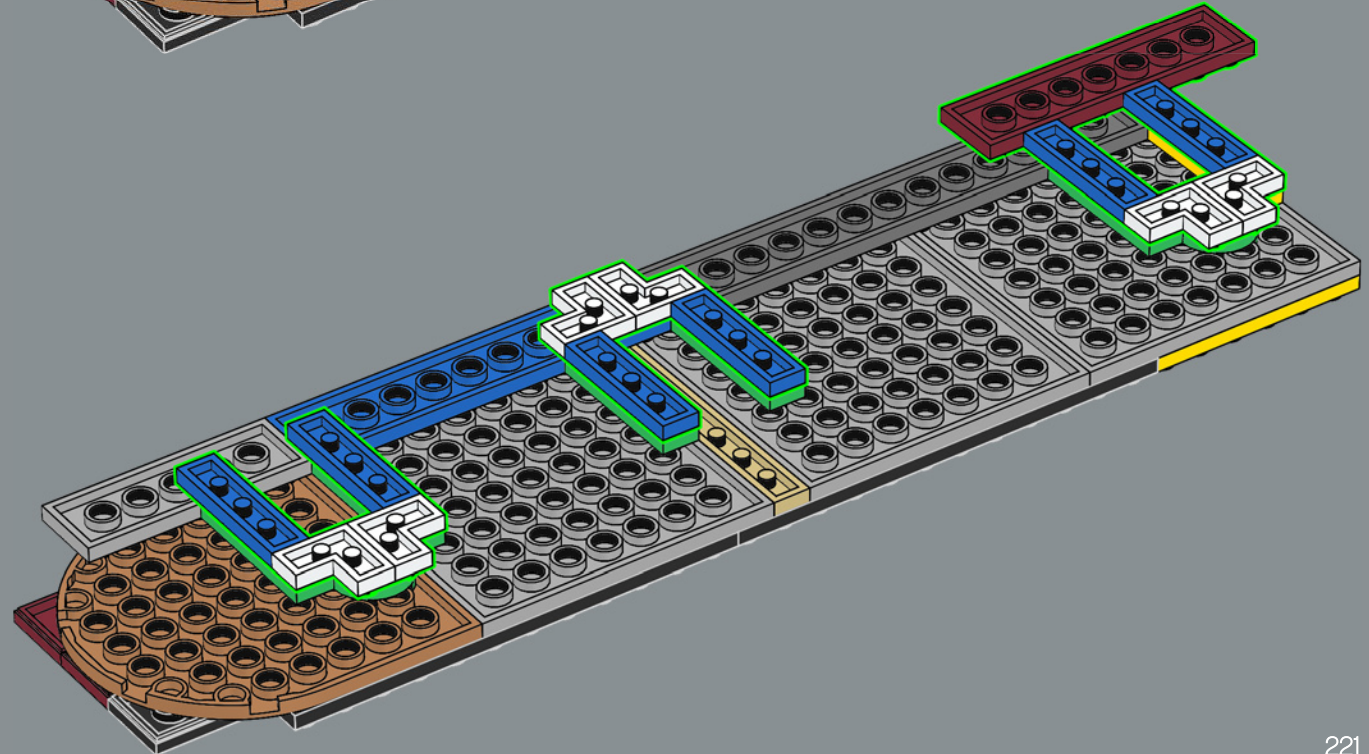

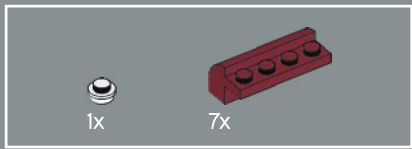

312

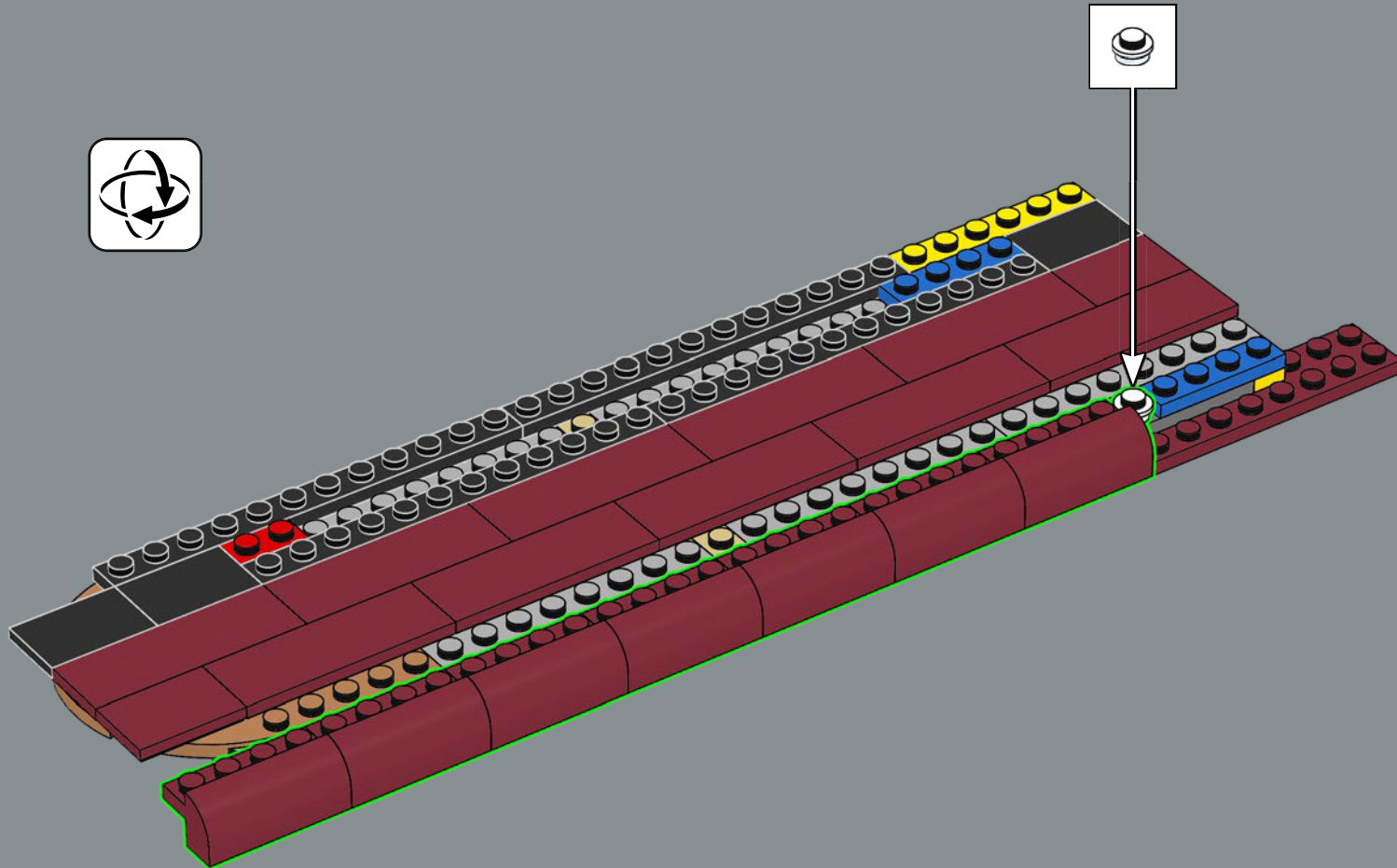

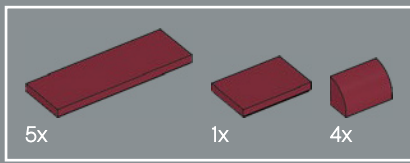

313

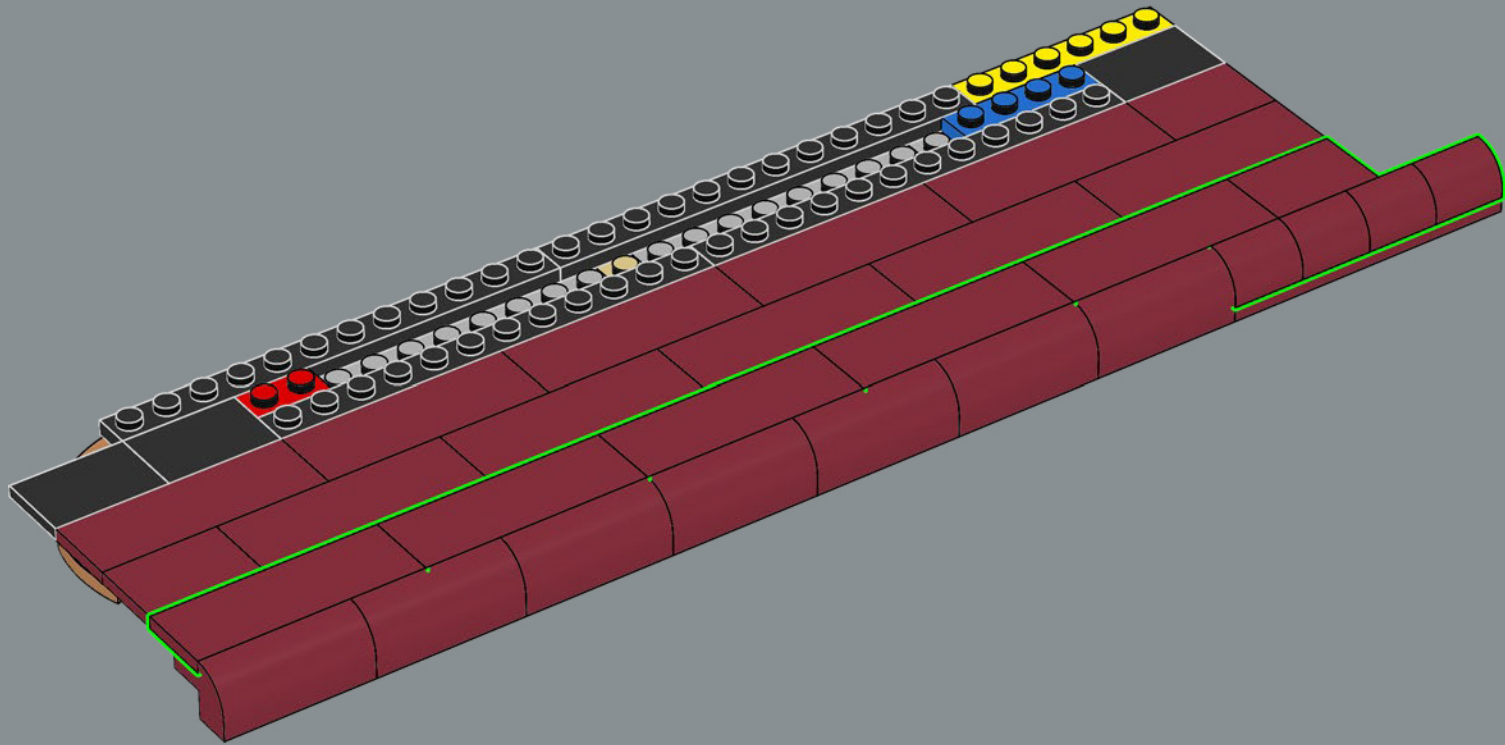





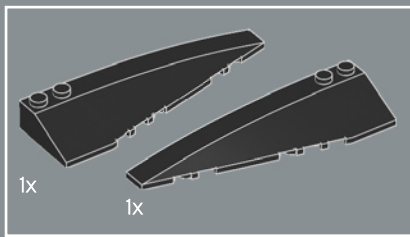

315

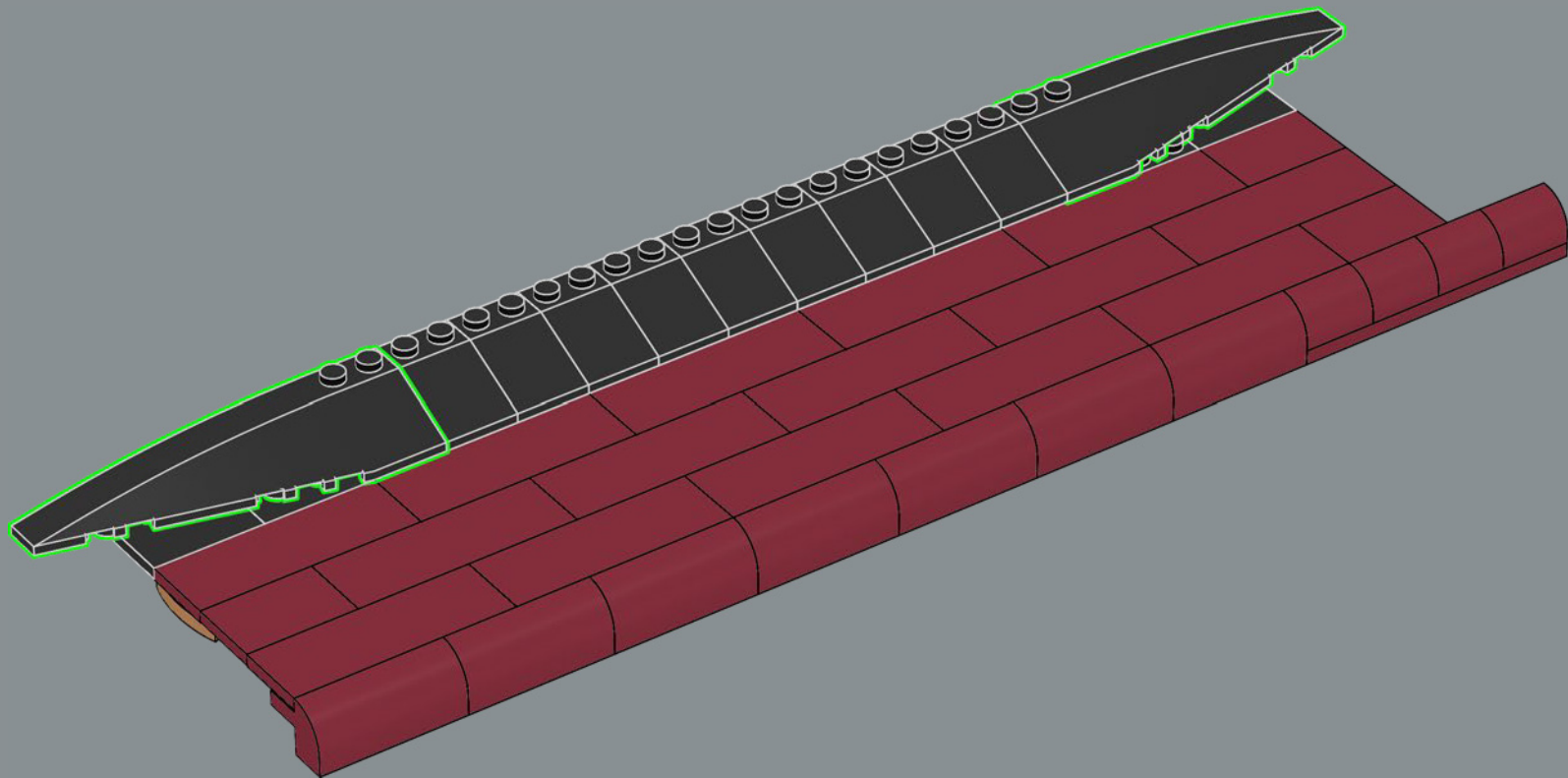

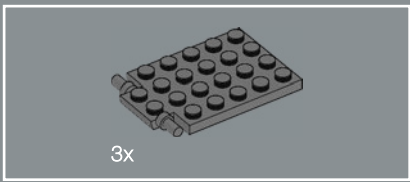

316

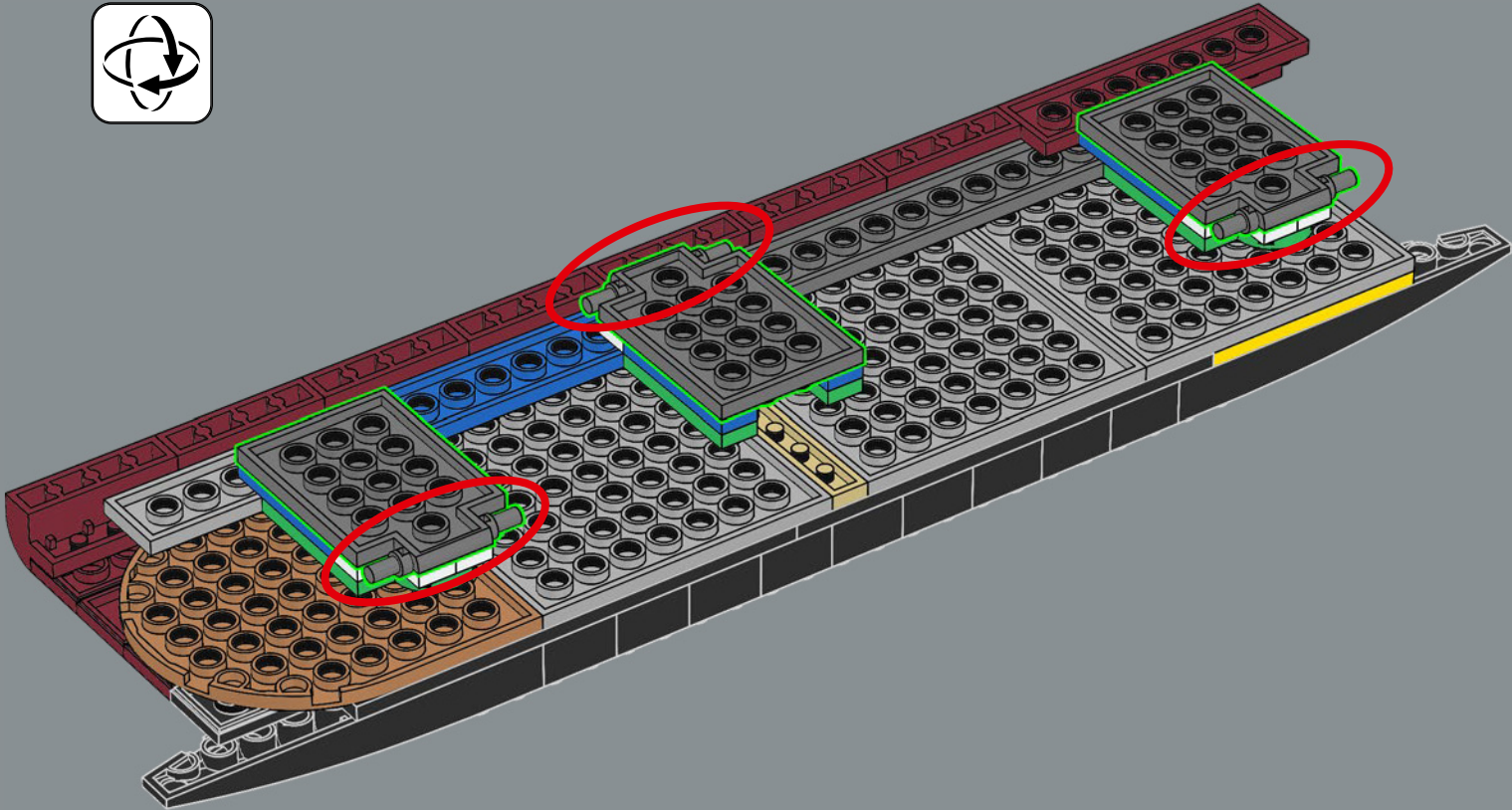



317

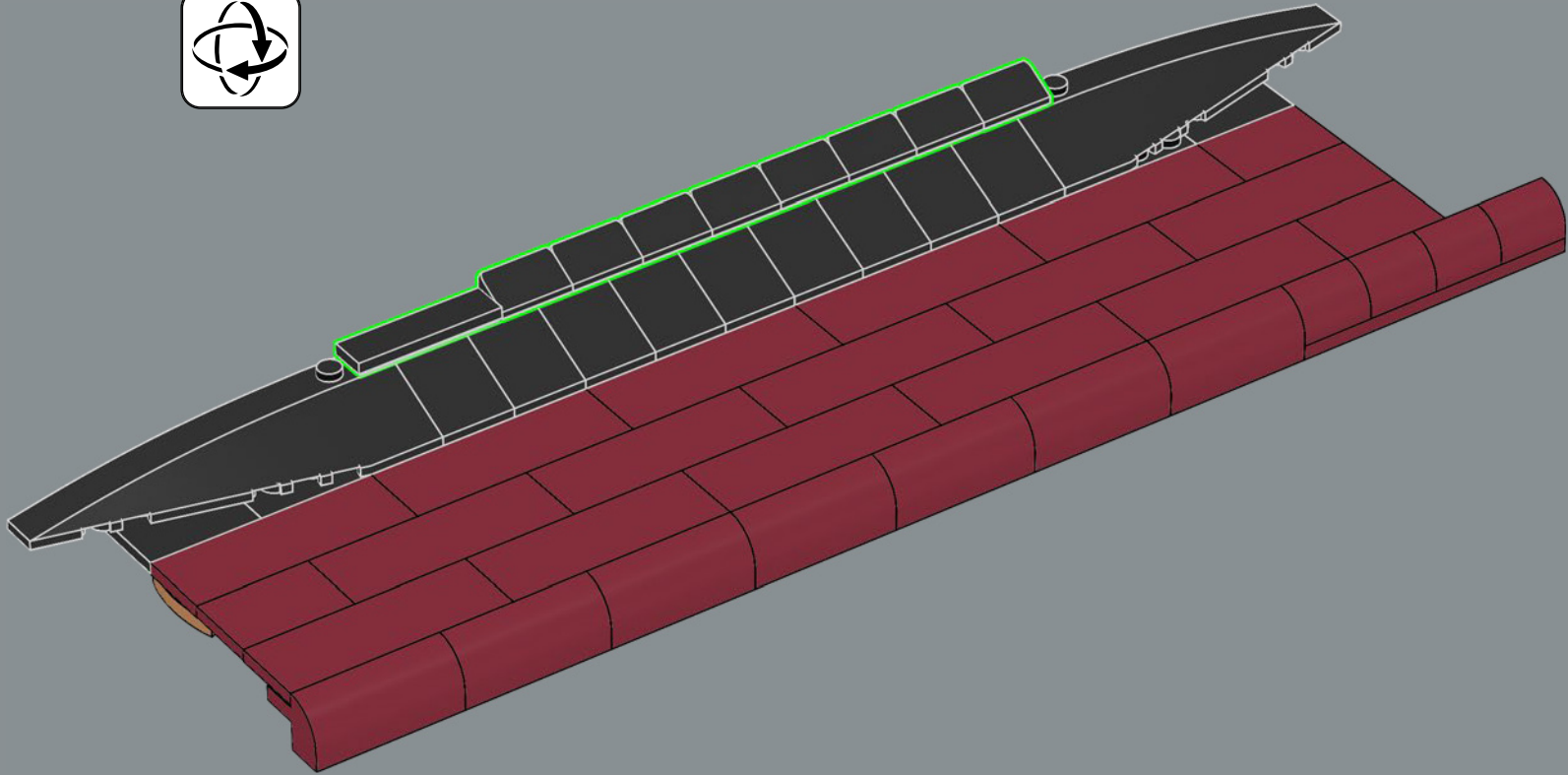

318

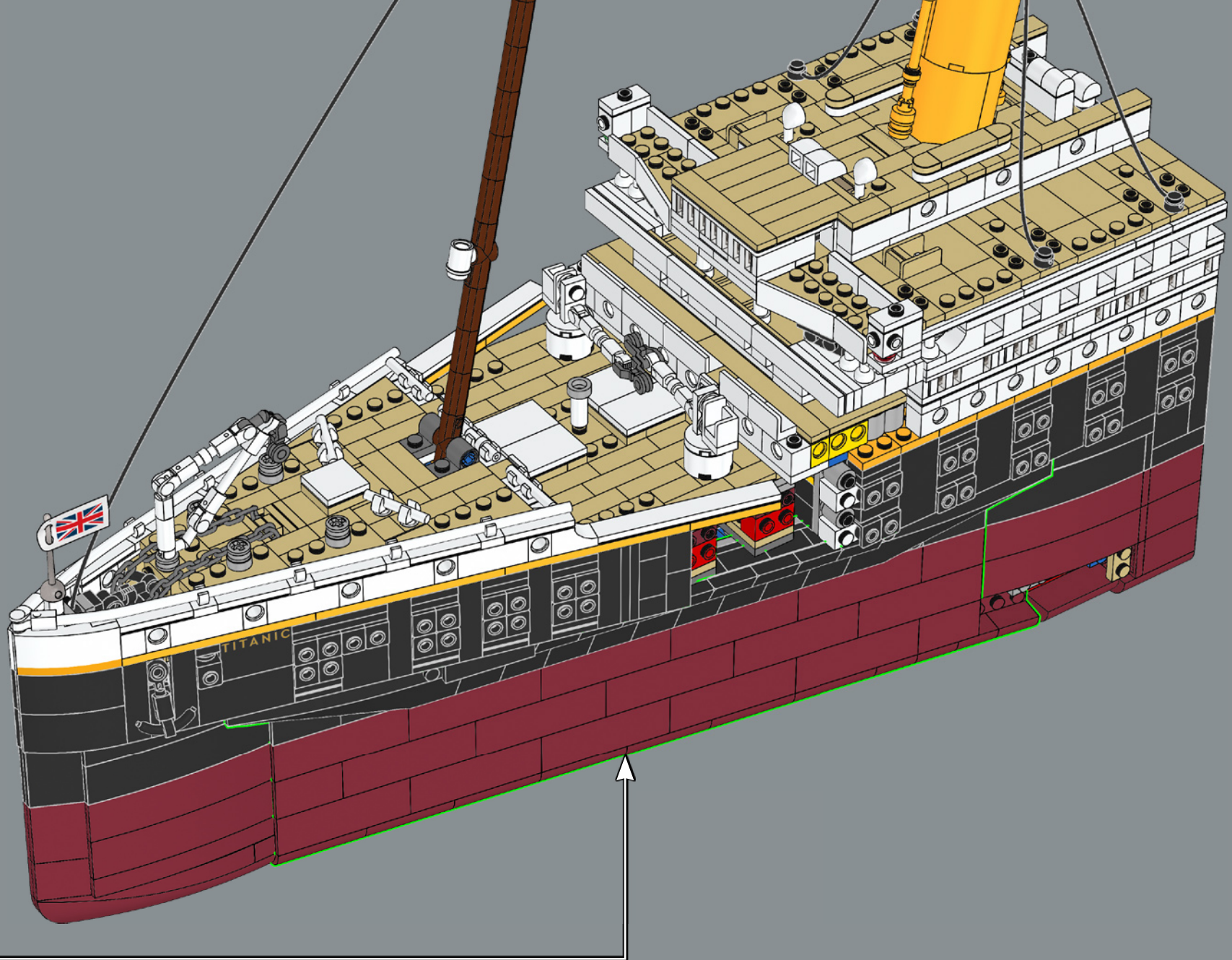

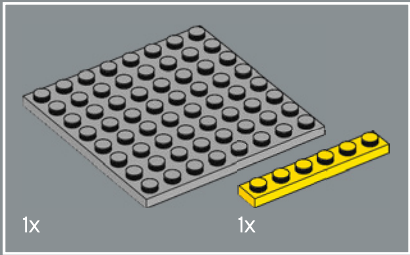
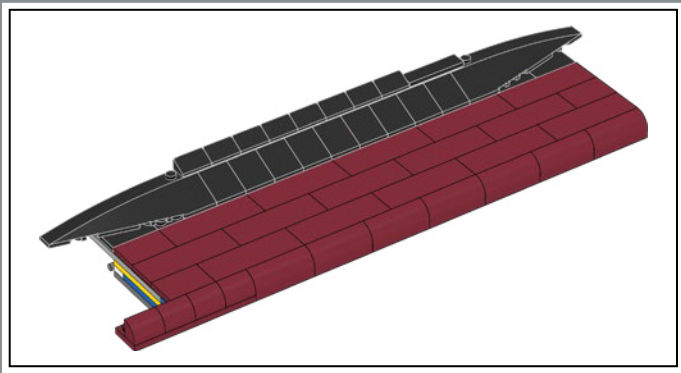

319

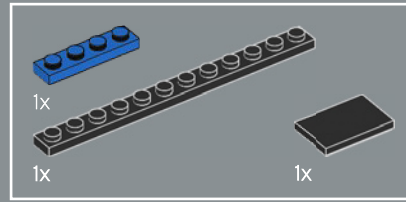
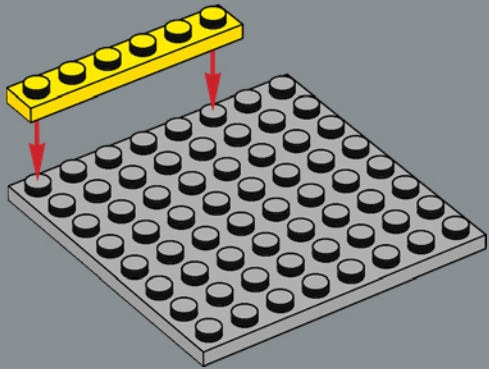

320

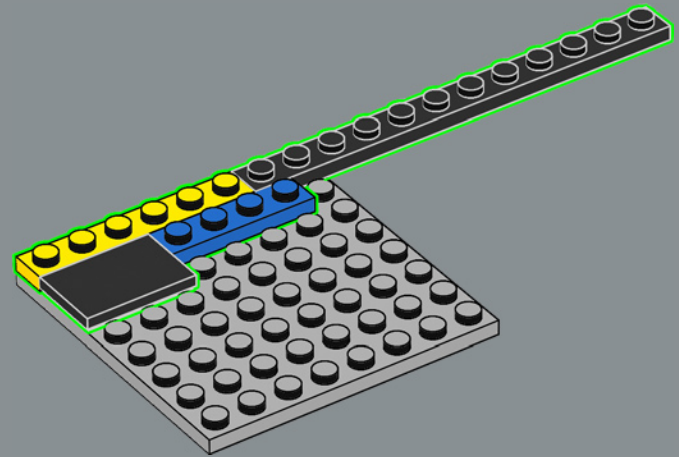

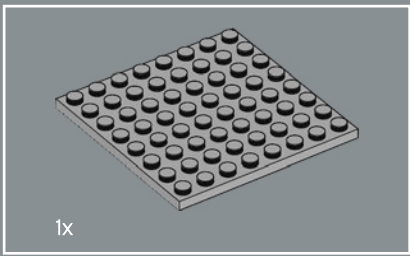

321

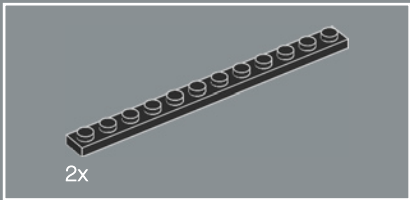
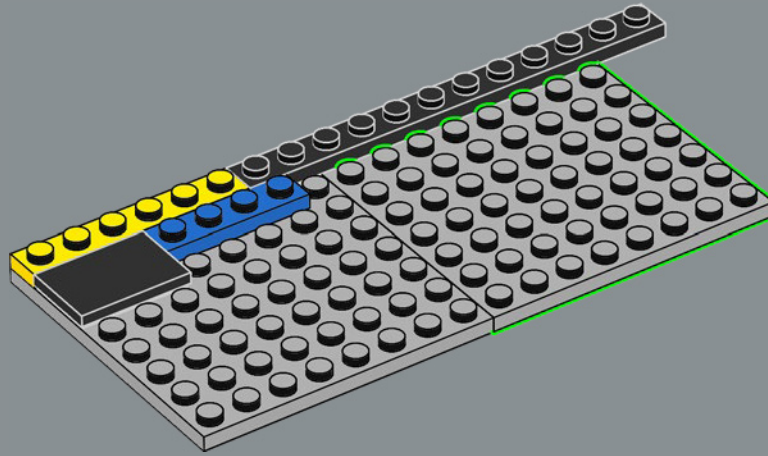

322

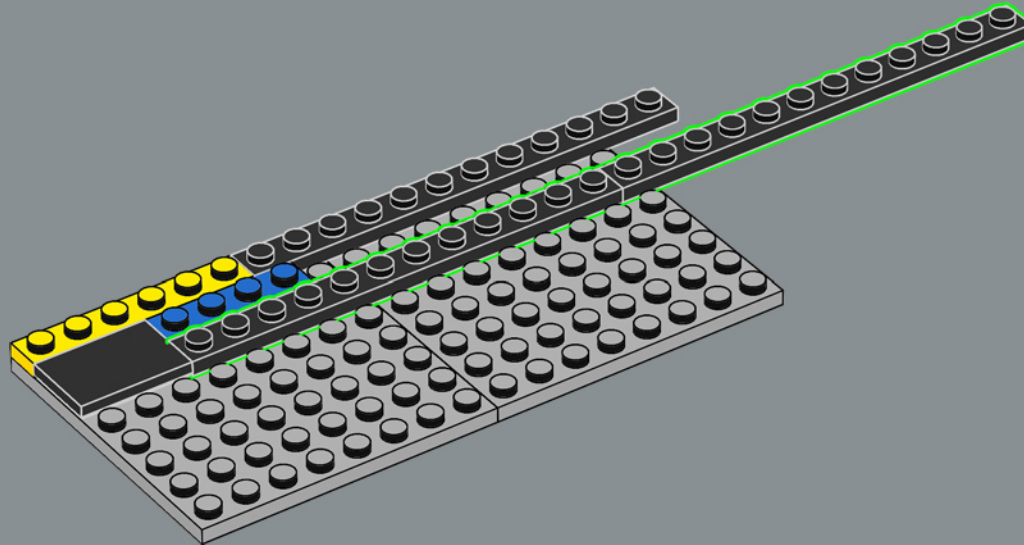

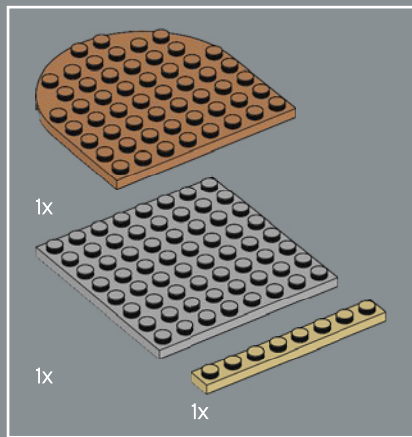

323

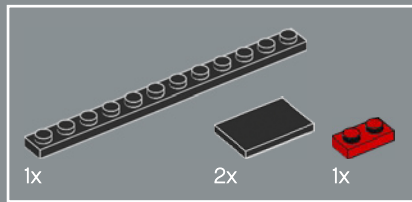
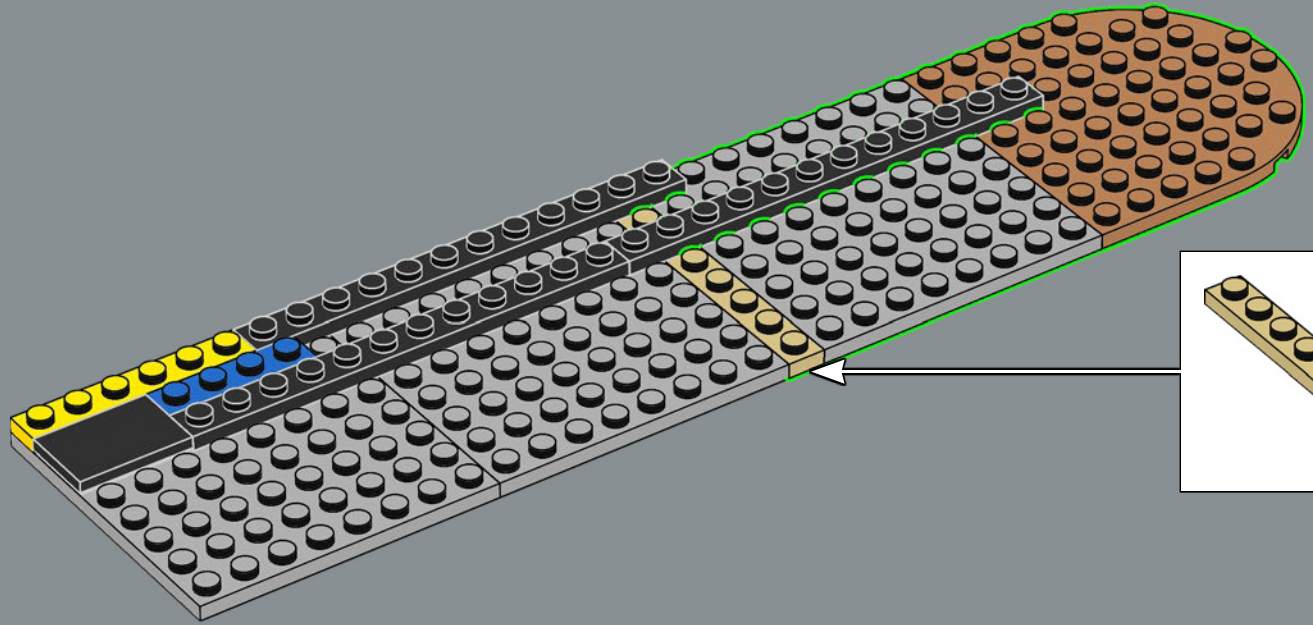

324

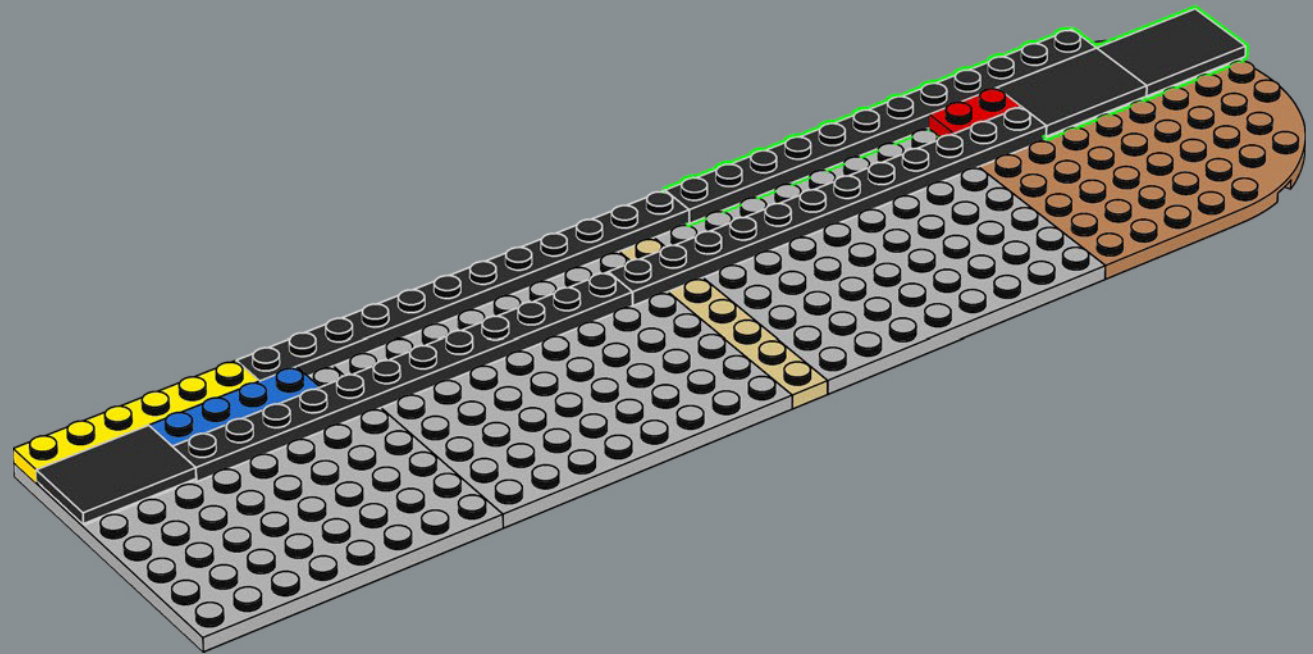

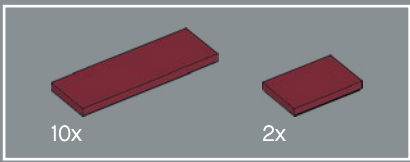

325

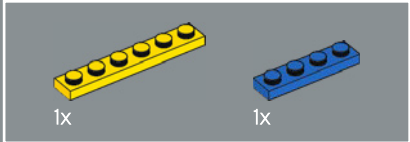
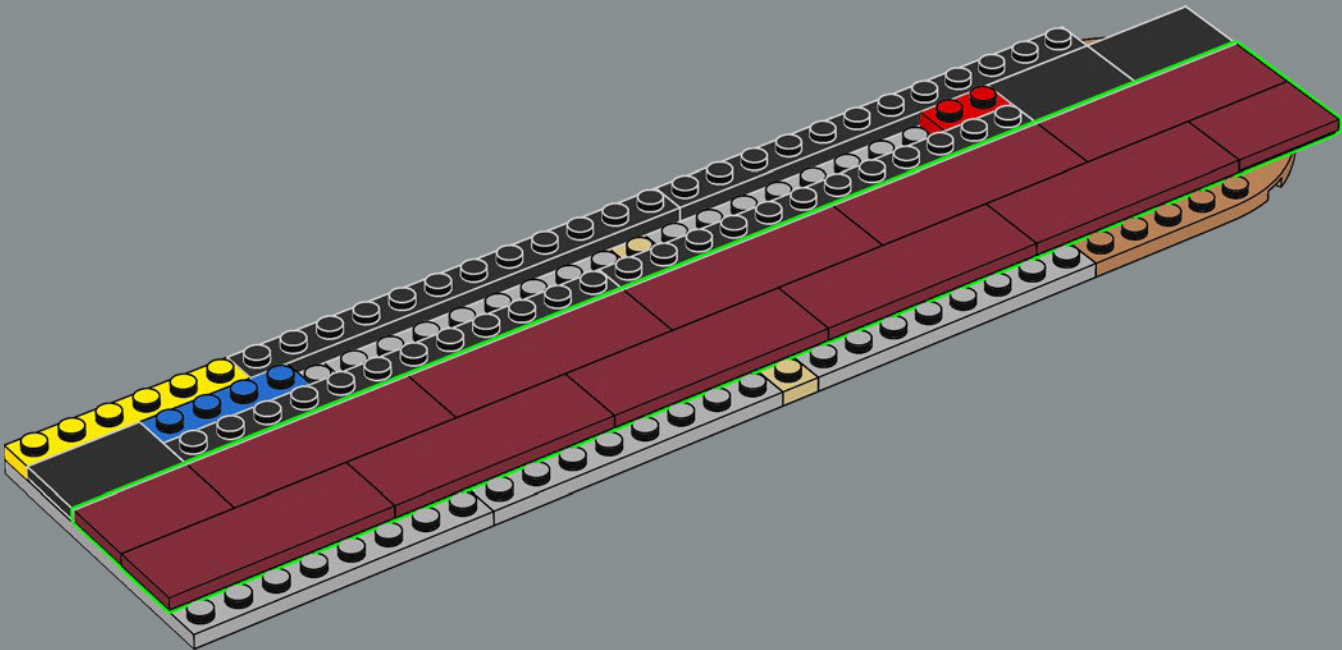

326

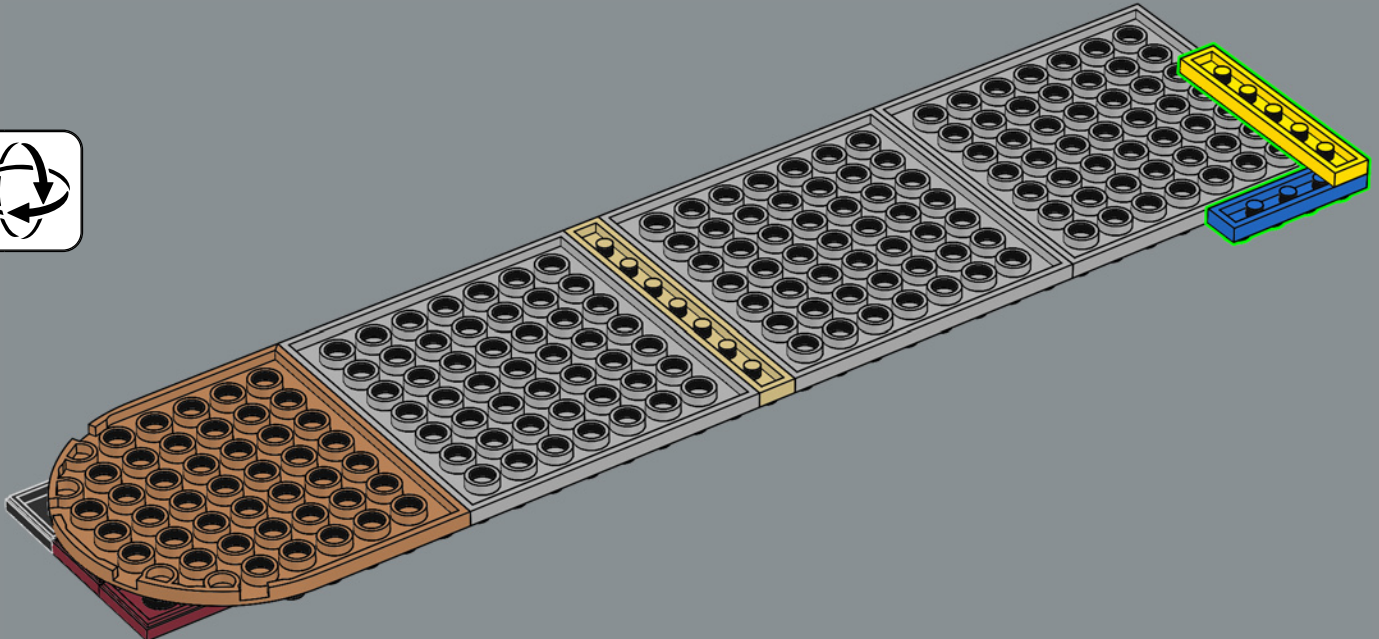



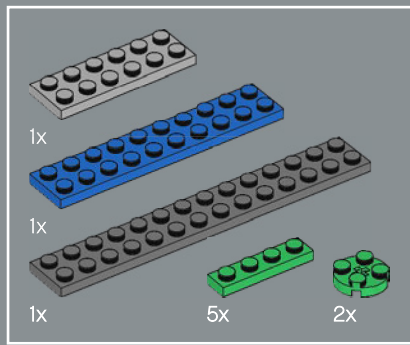

327

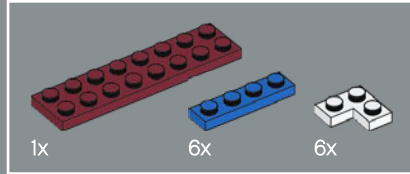
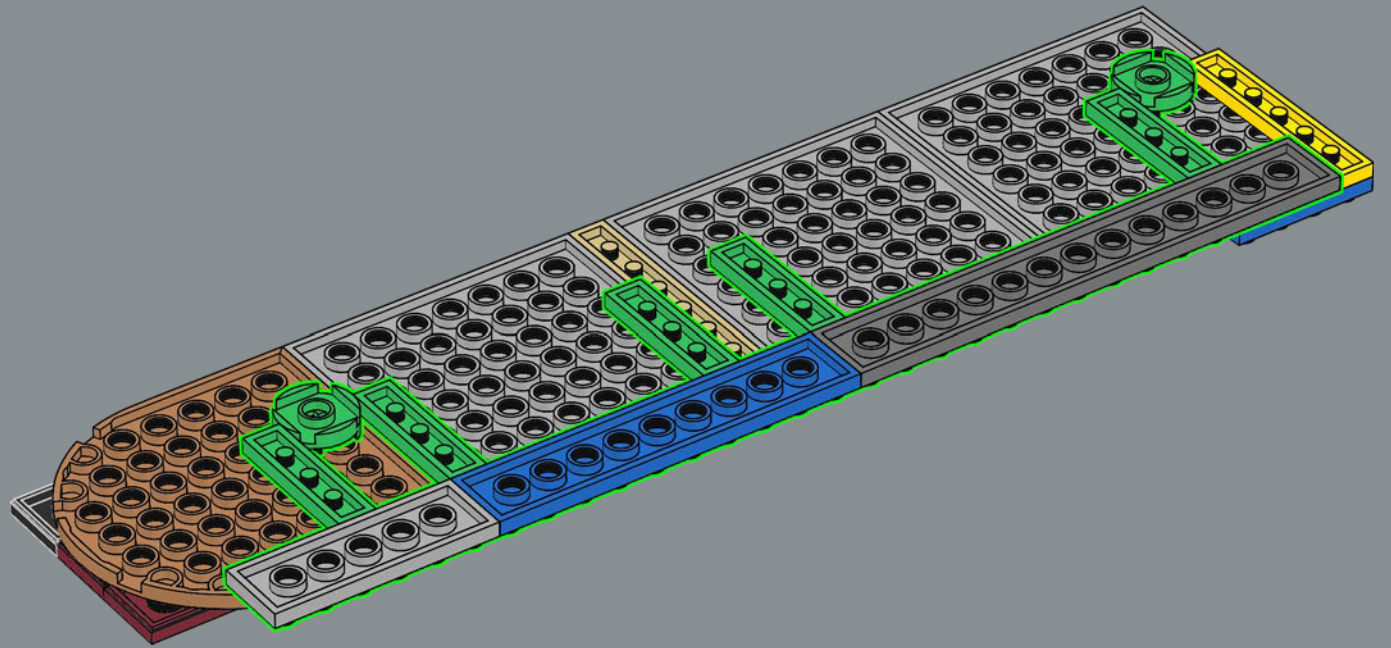

328

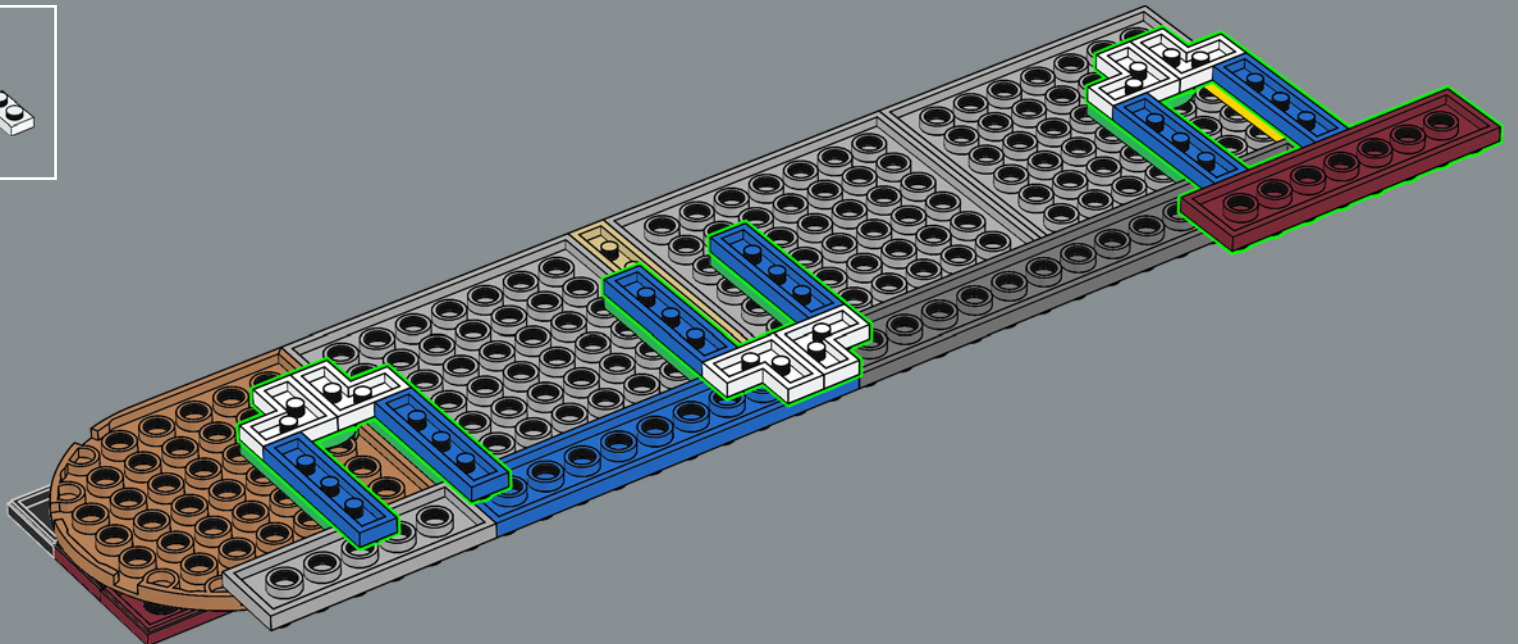

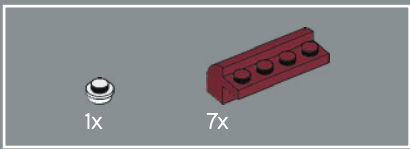

329

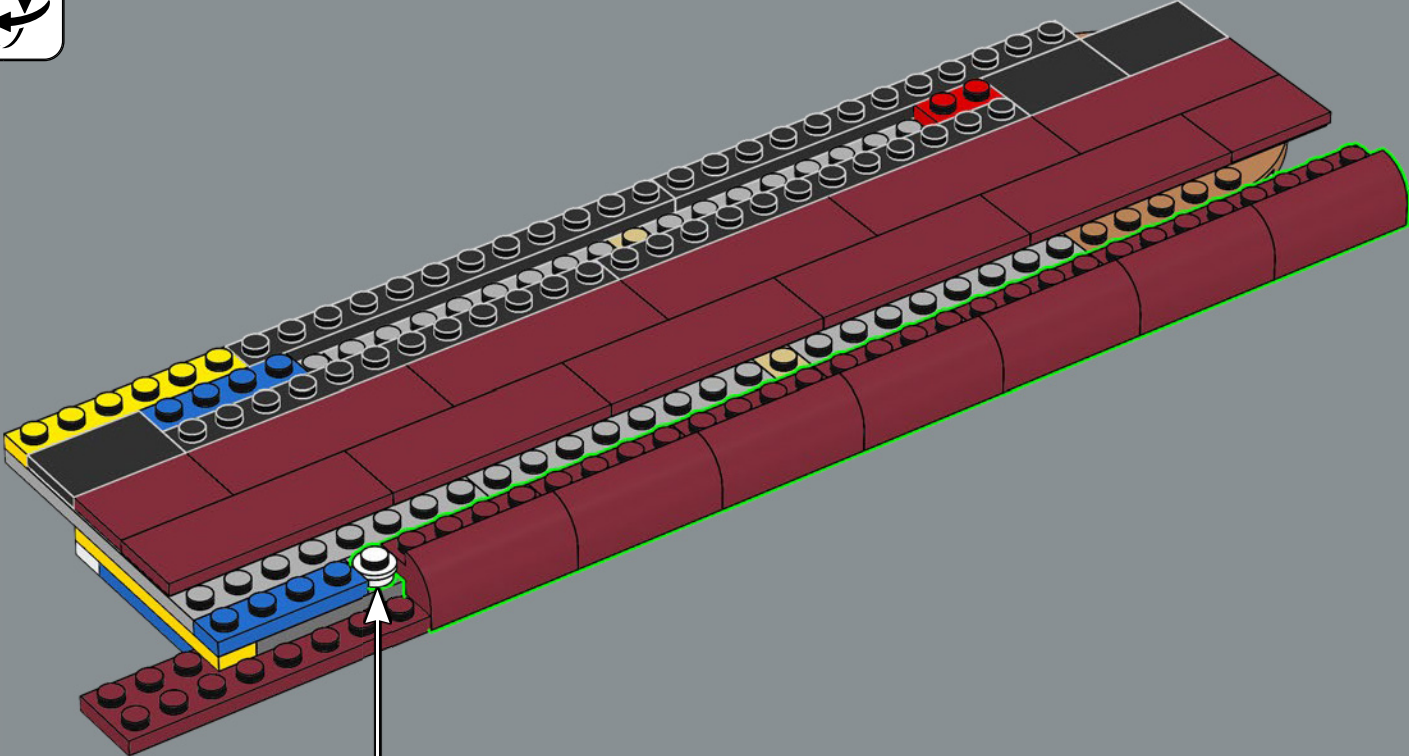

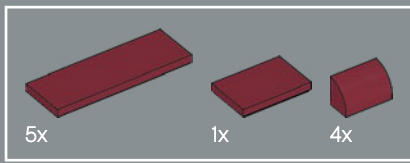

330

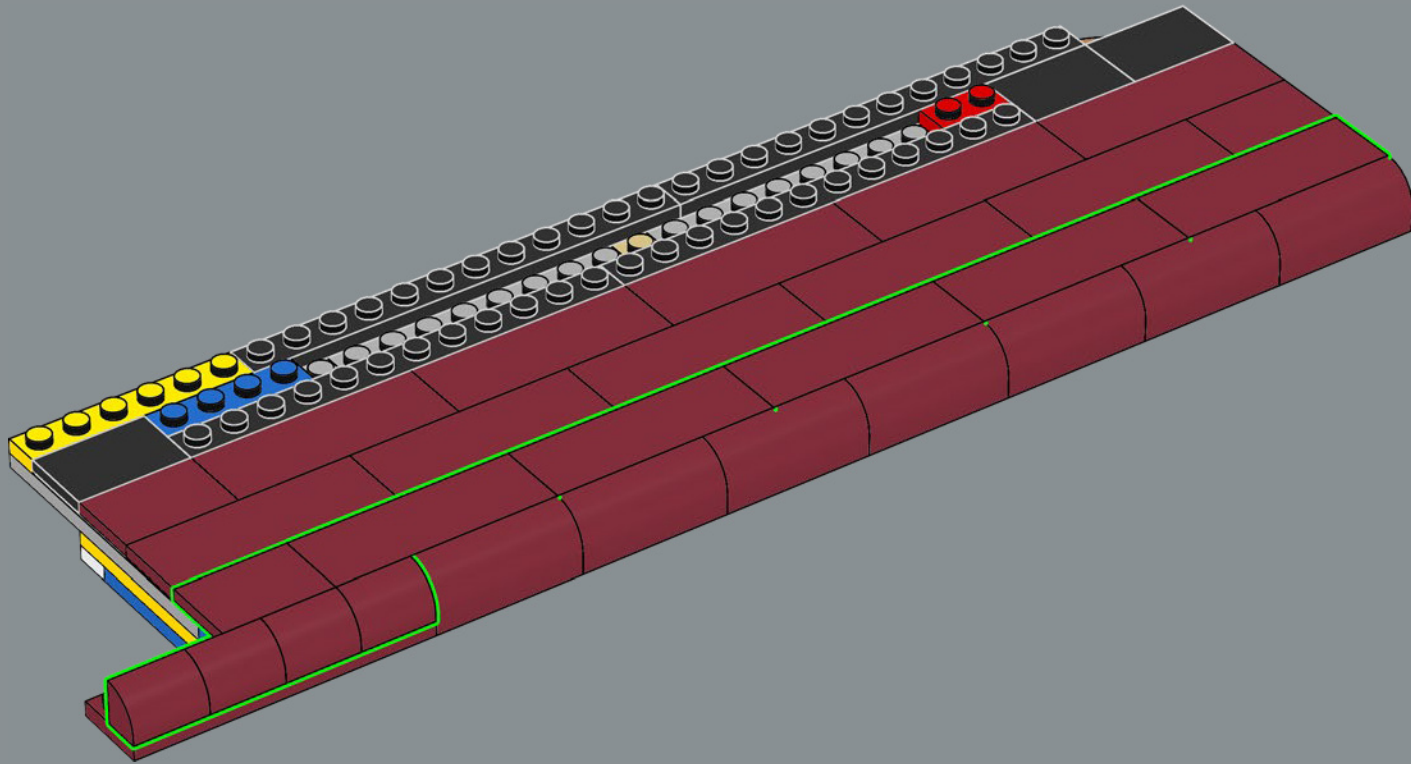



331

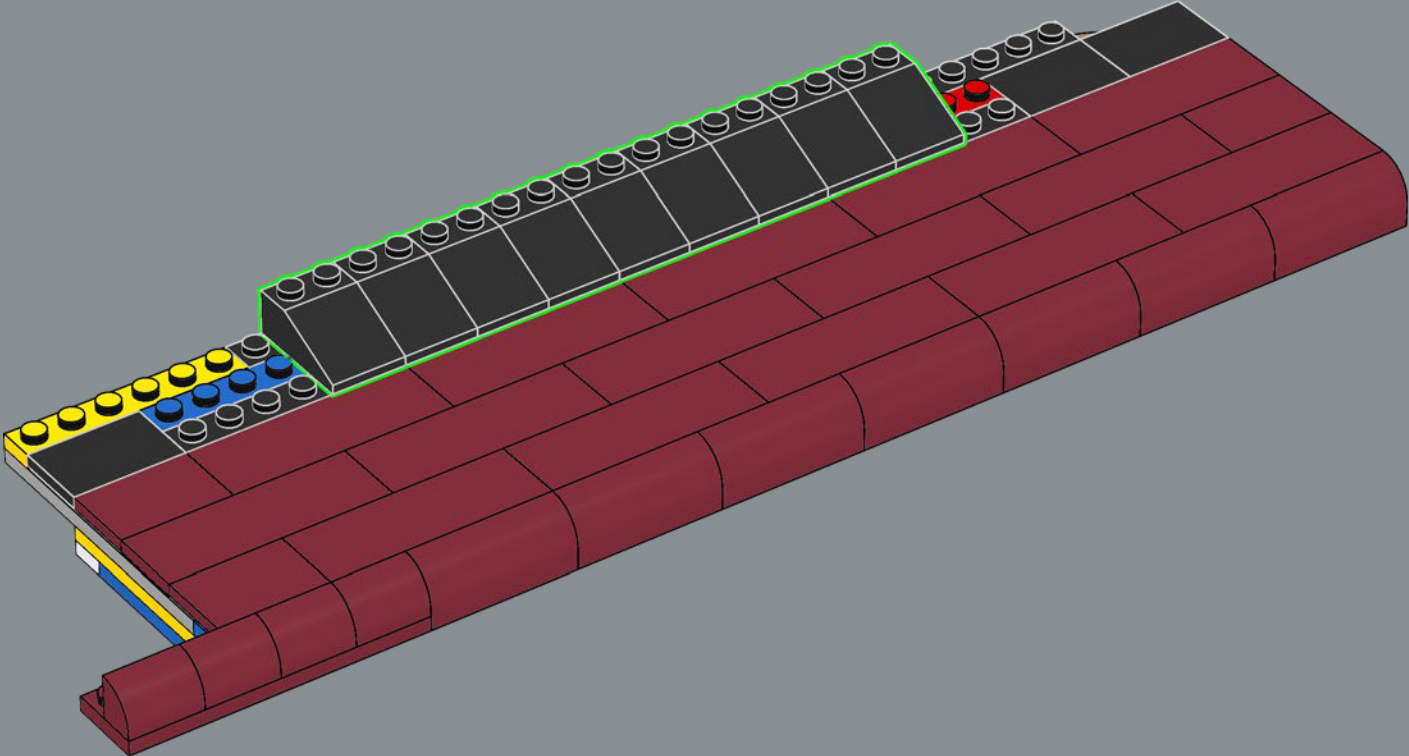

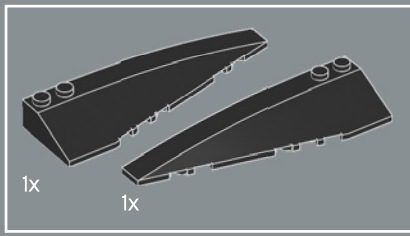

332

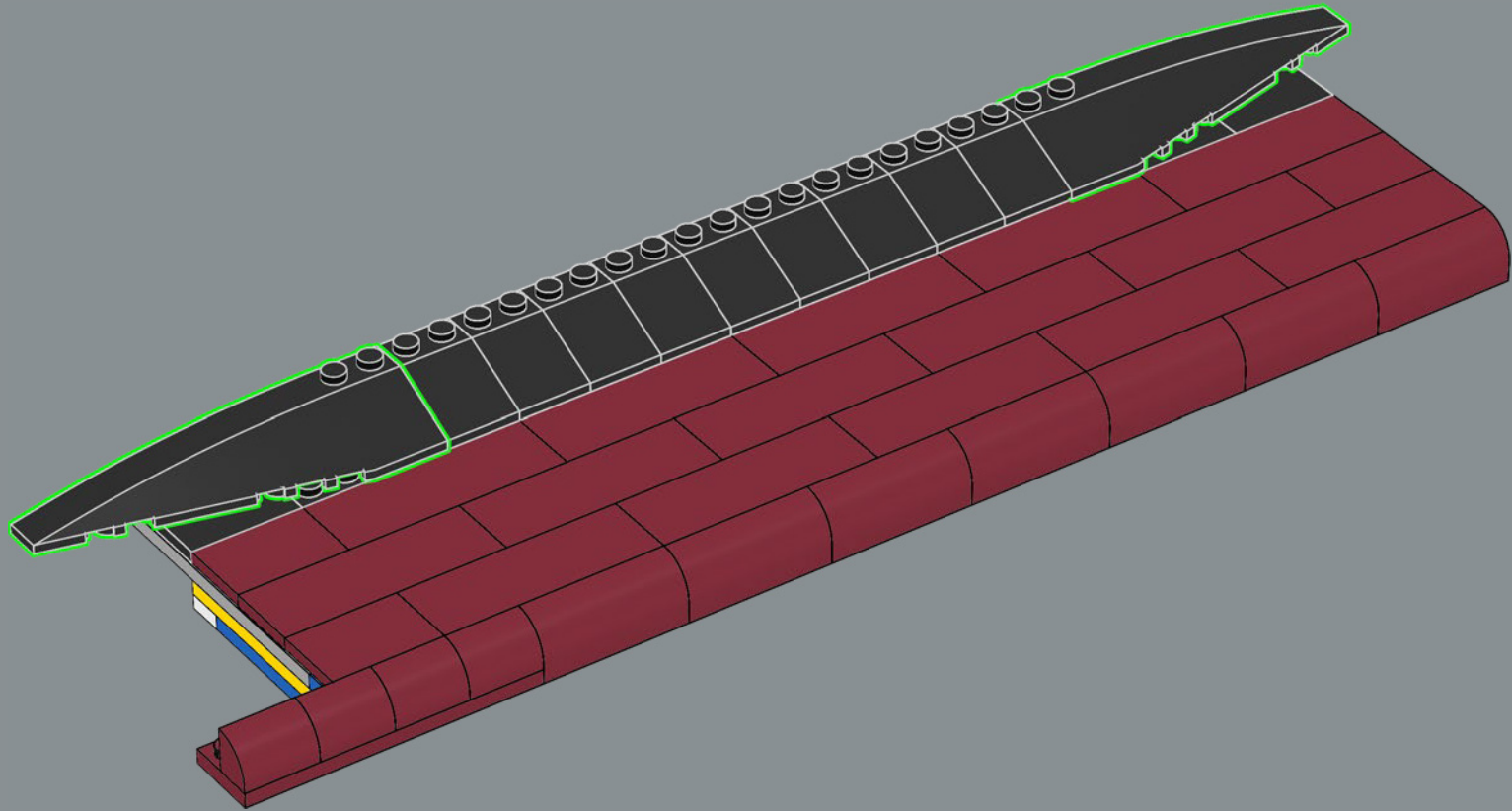

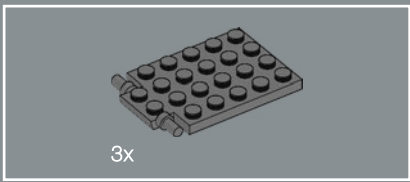

333

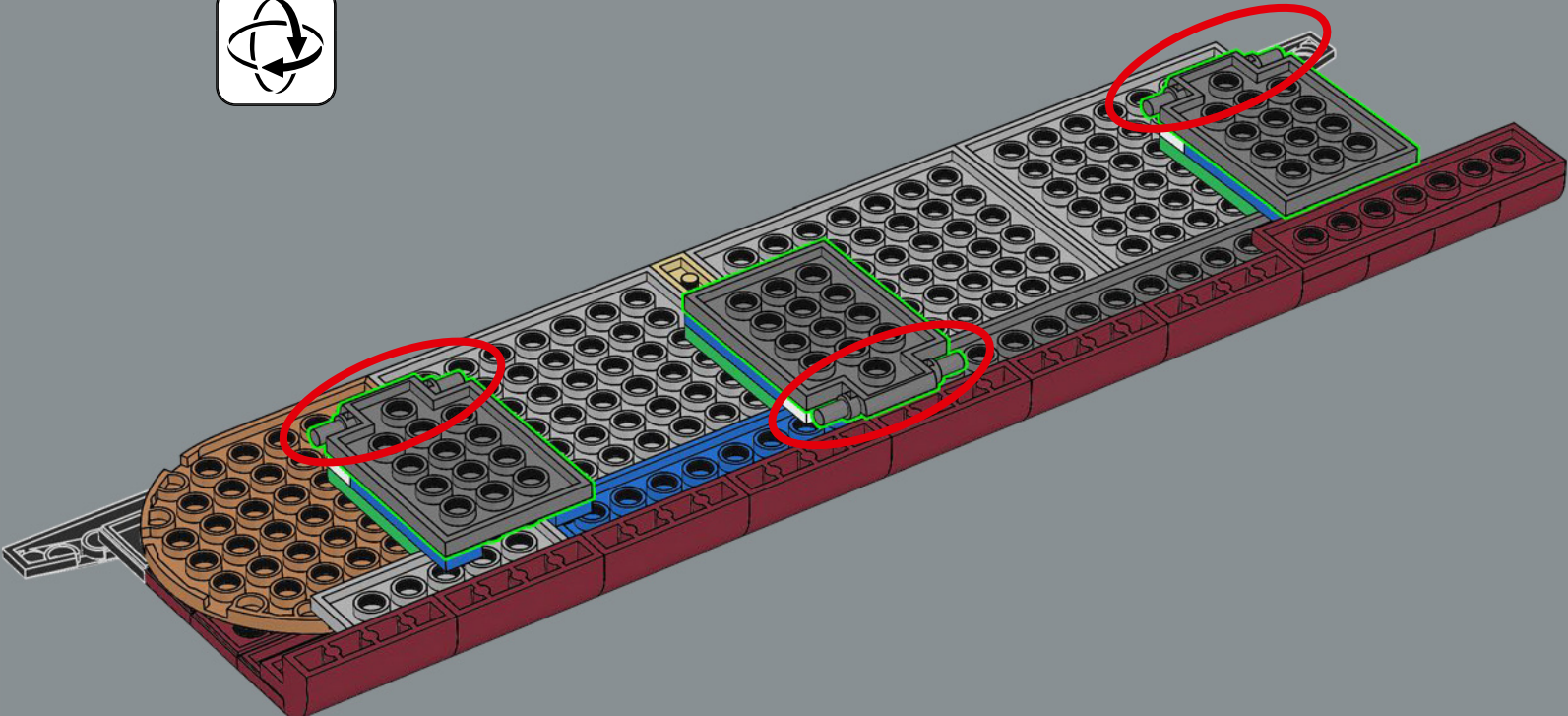



334

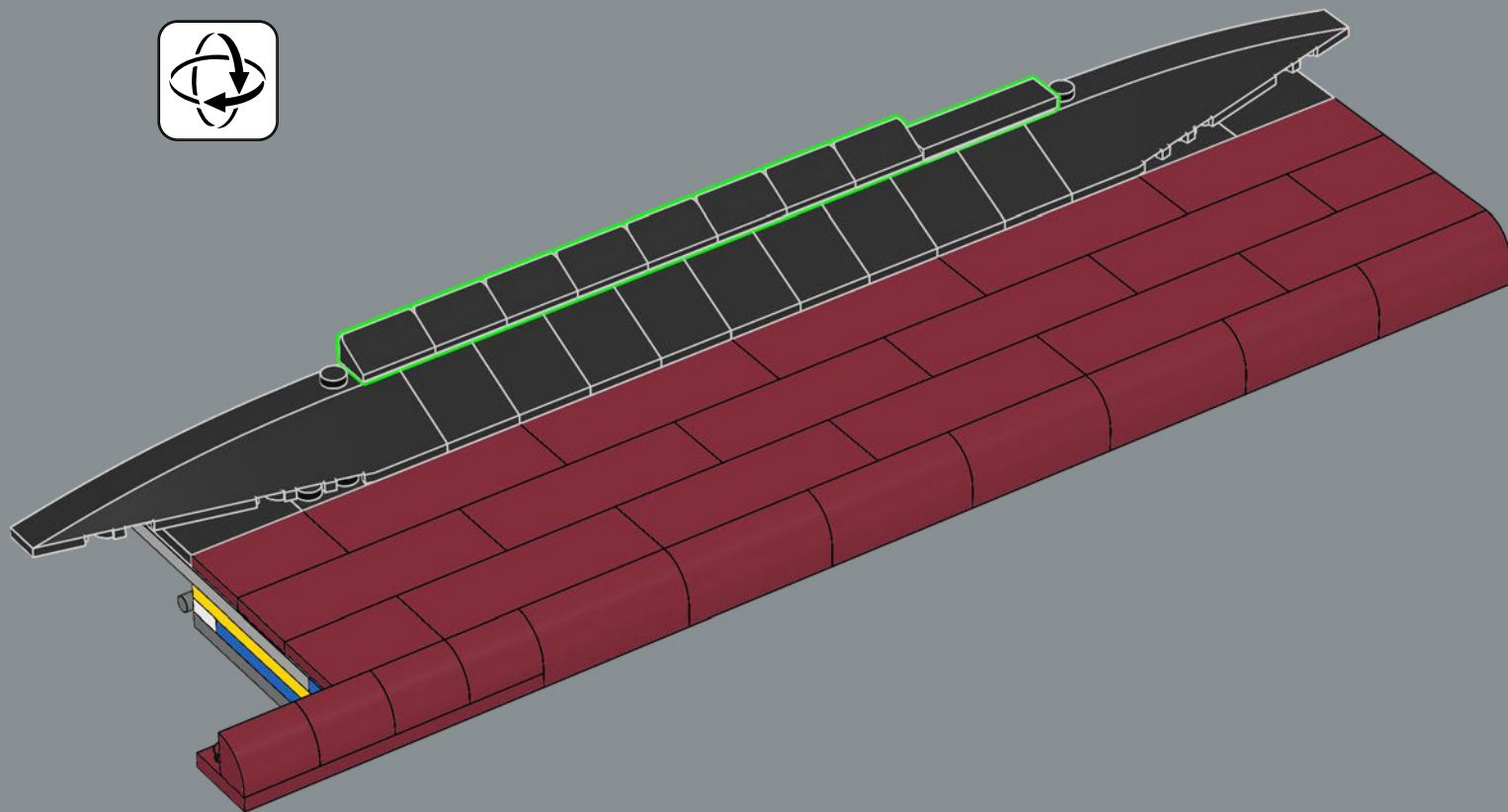

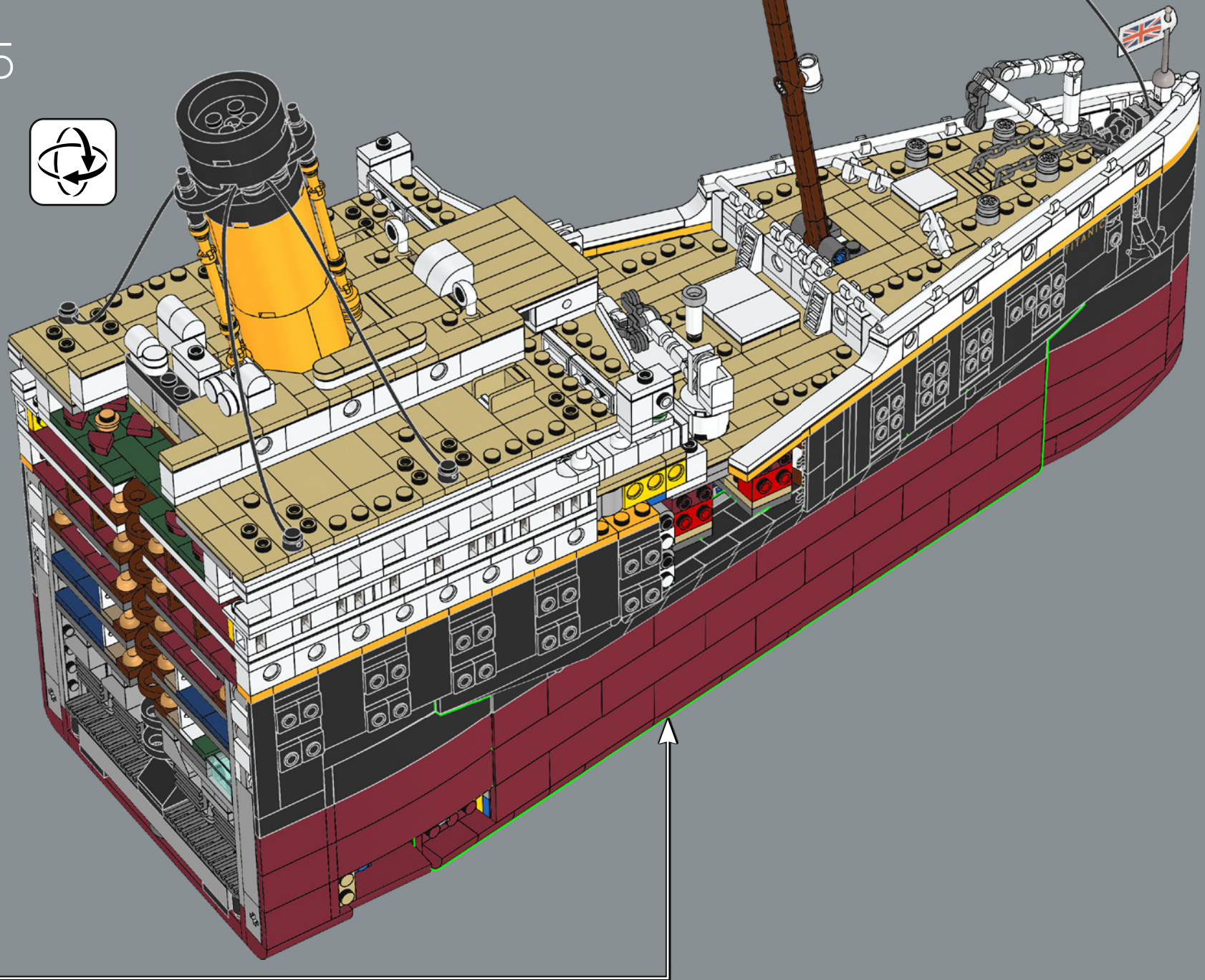



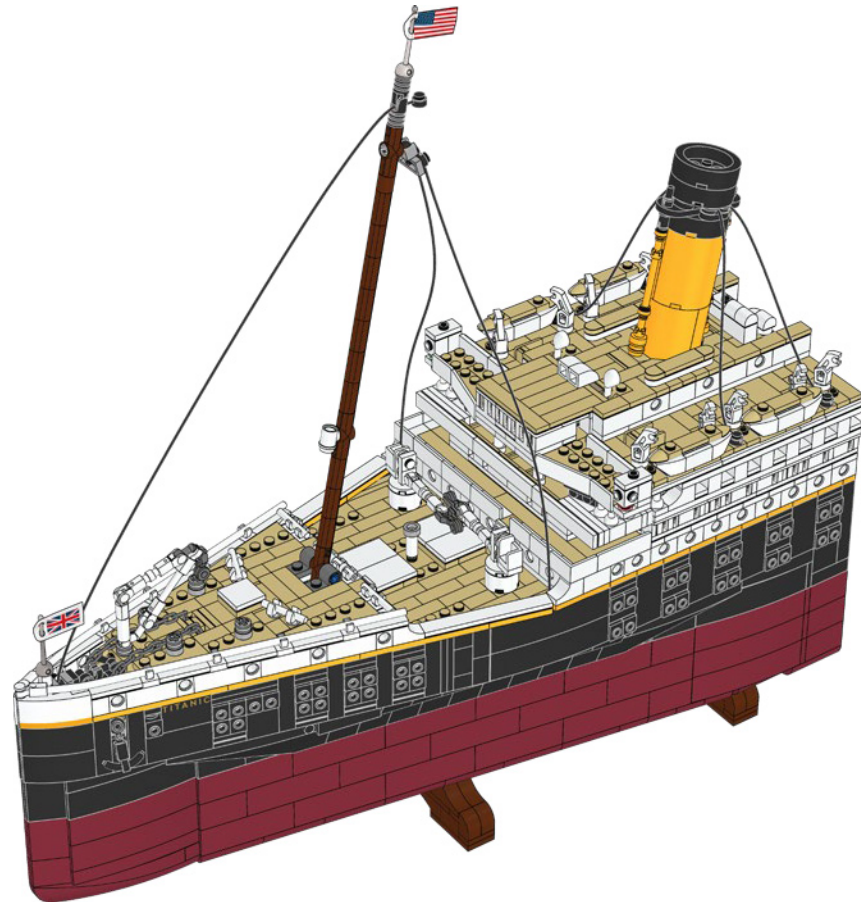
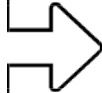

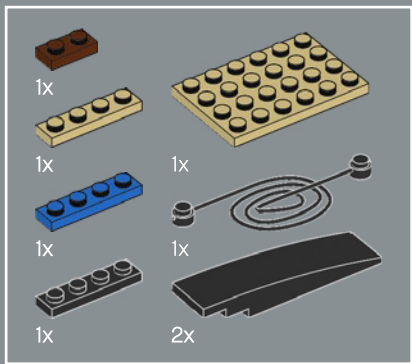

336

1

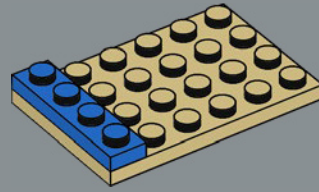

2

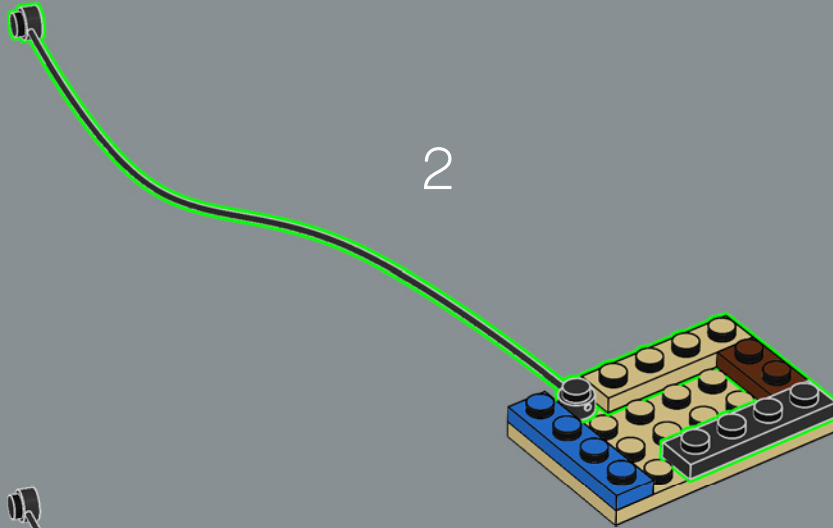

3

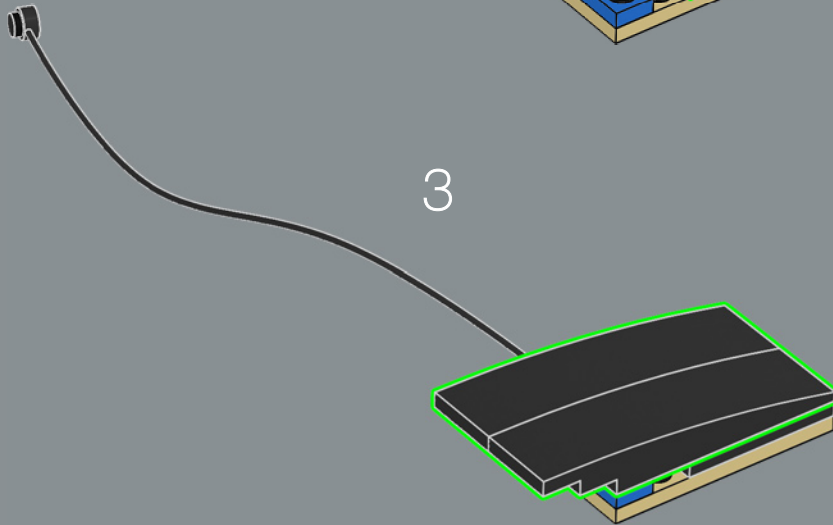

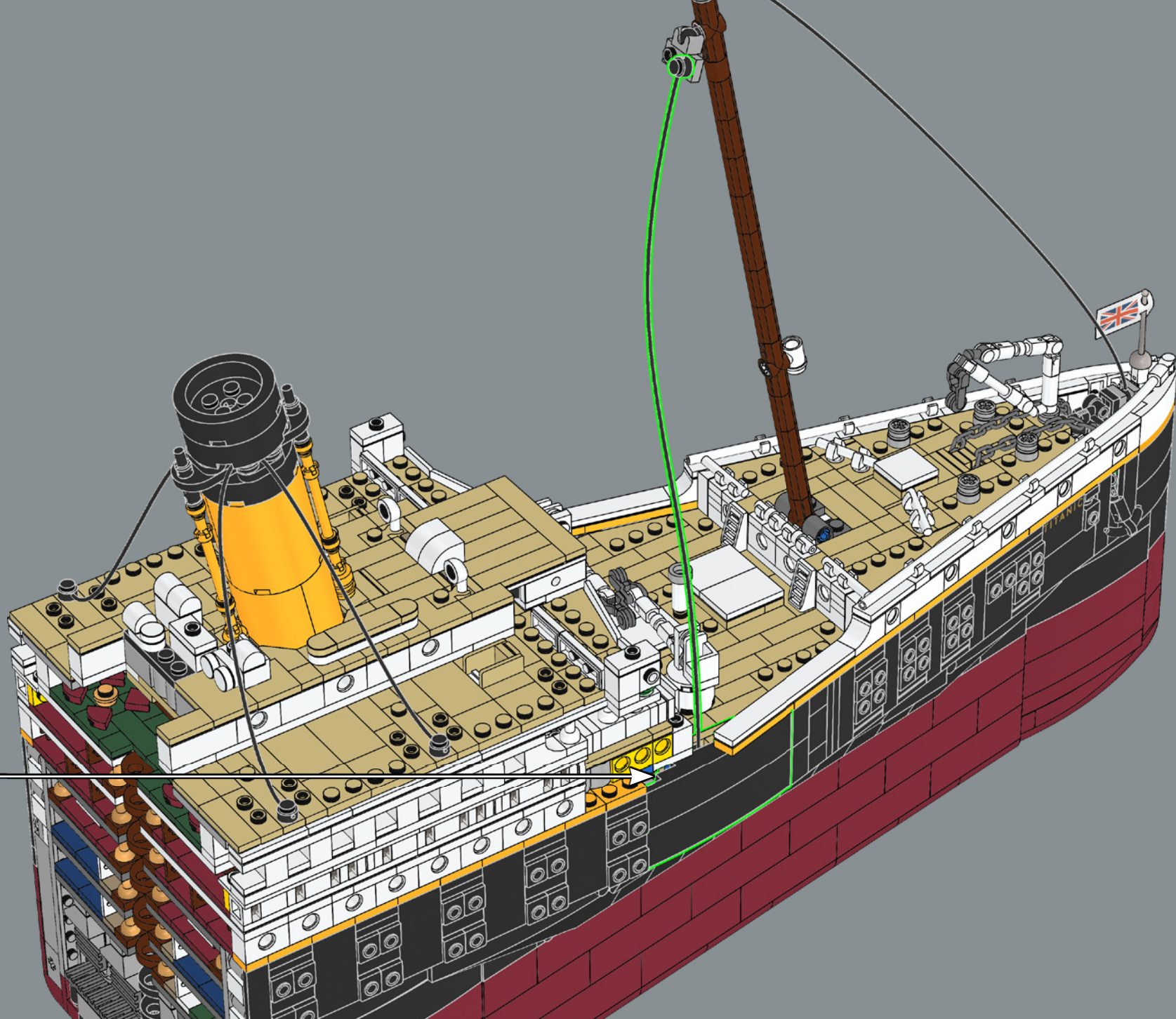

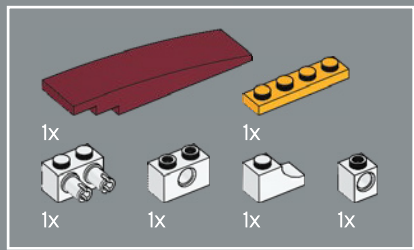

337

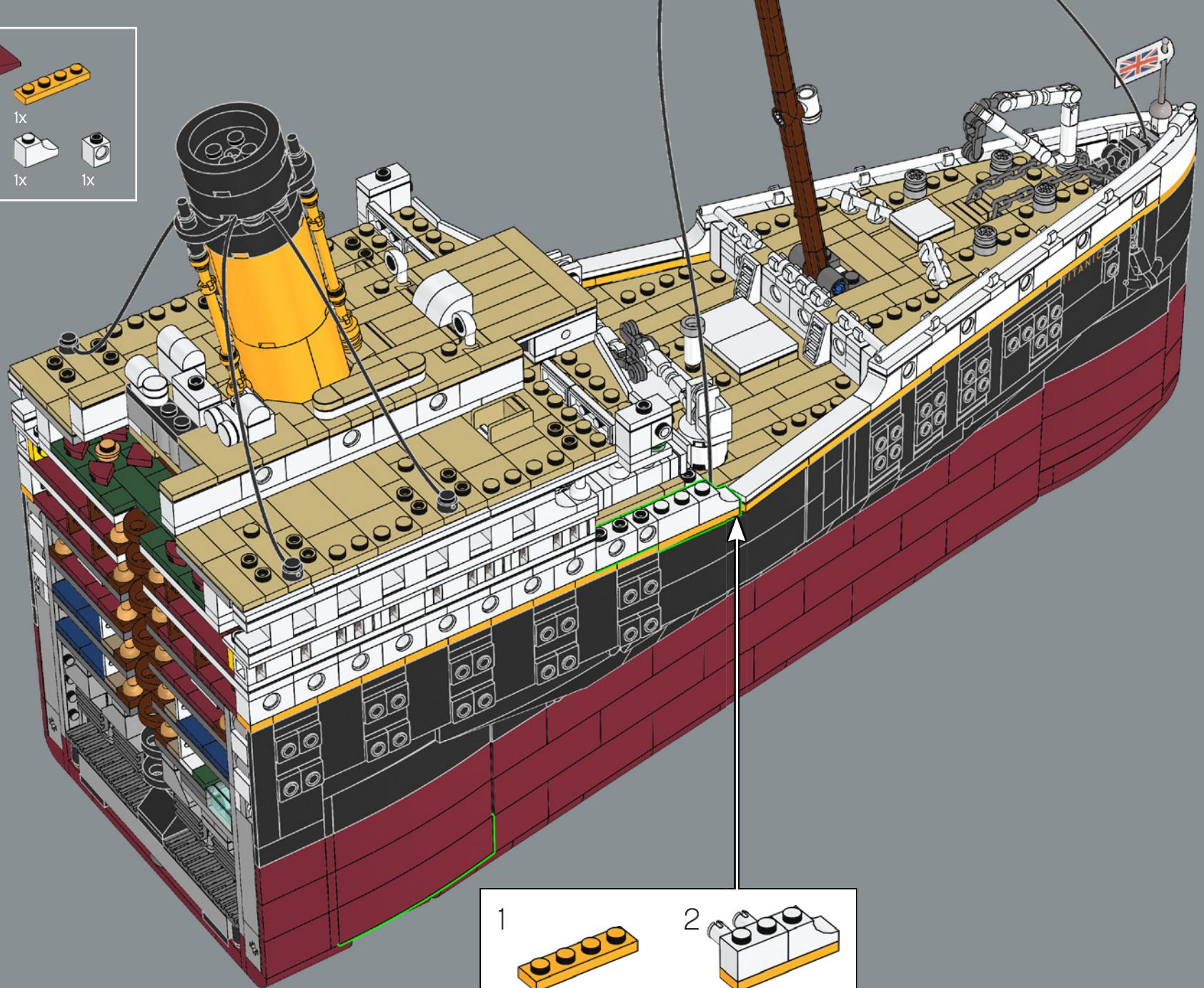

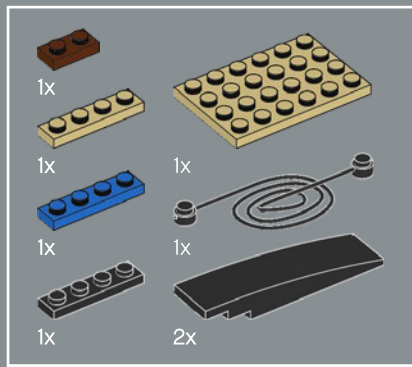

338

1

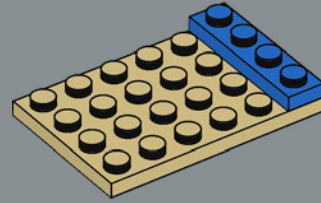

2

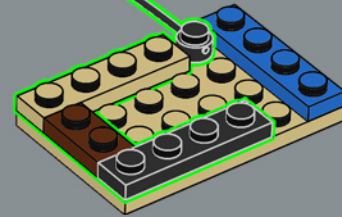

3

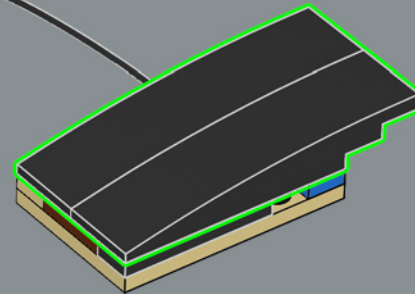

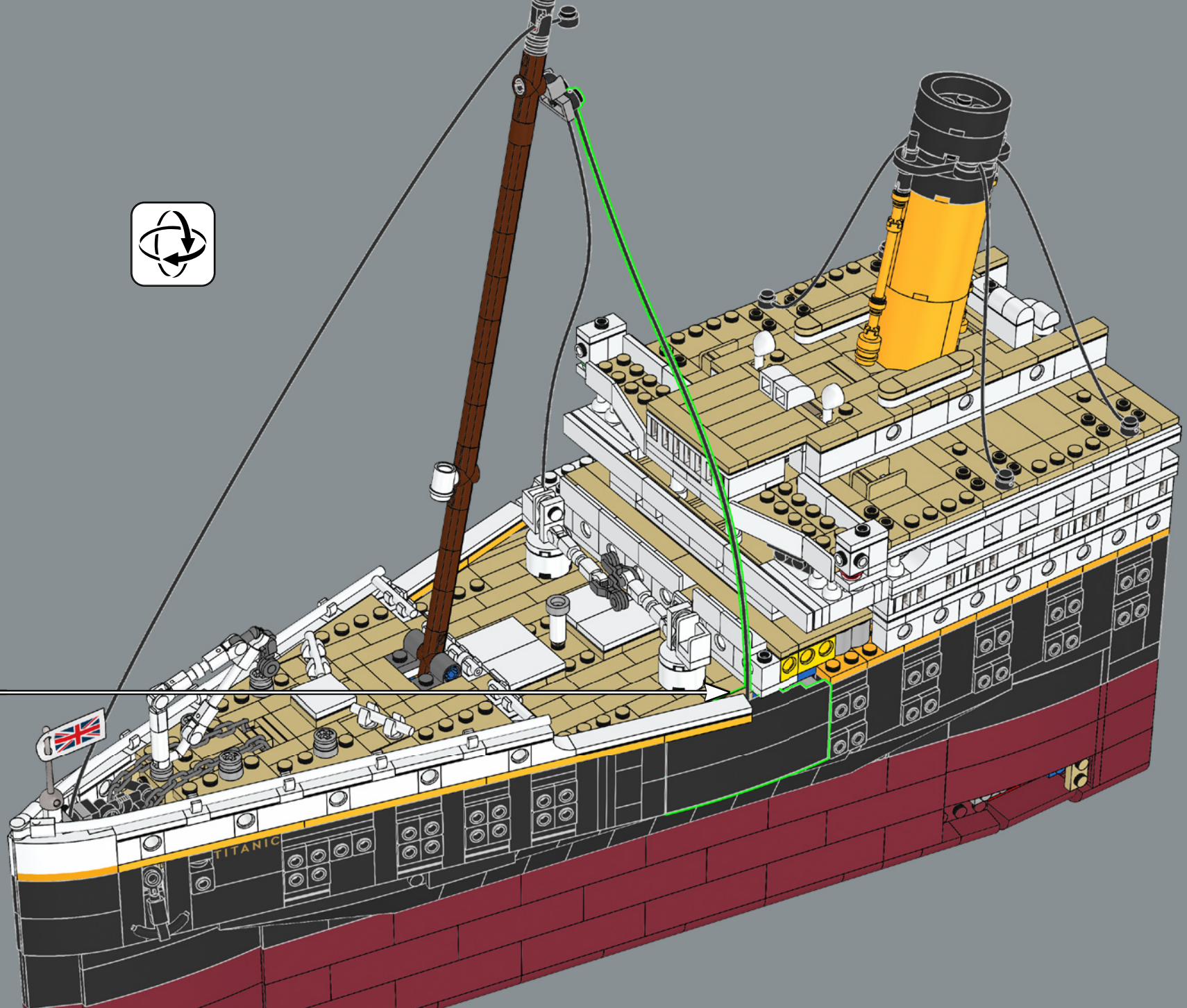

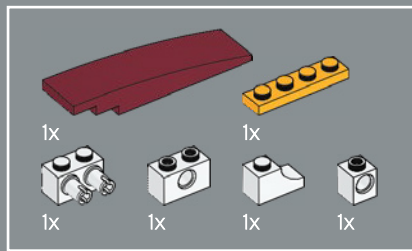

339

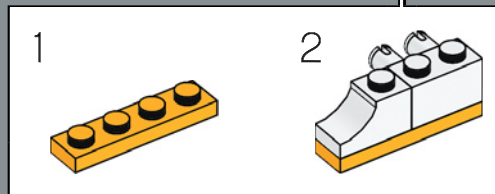
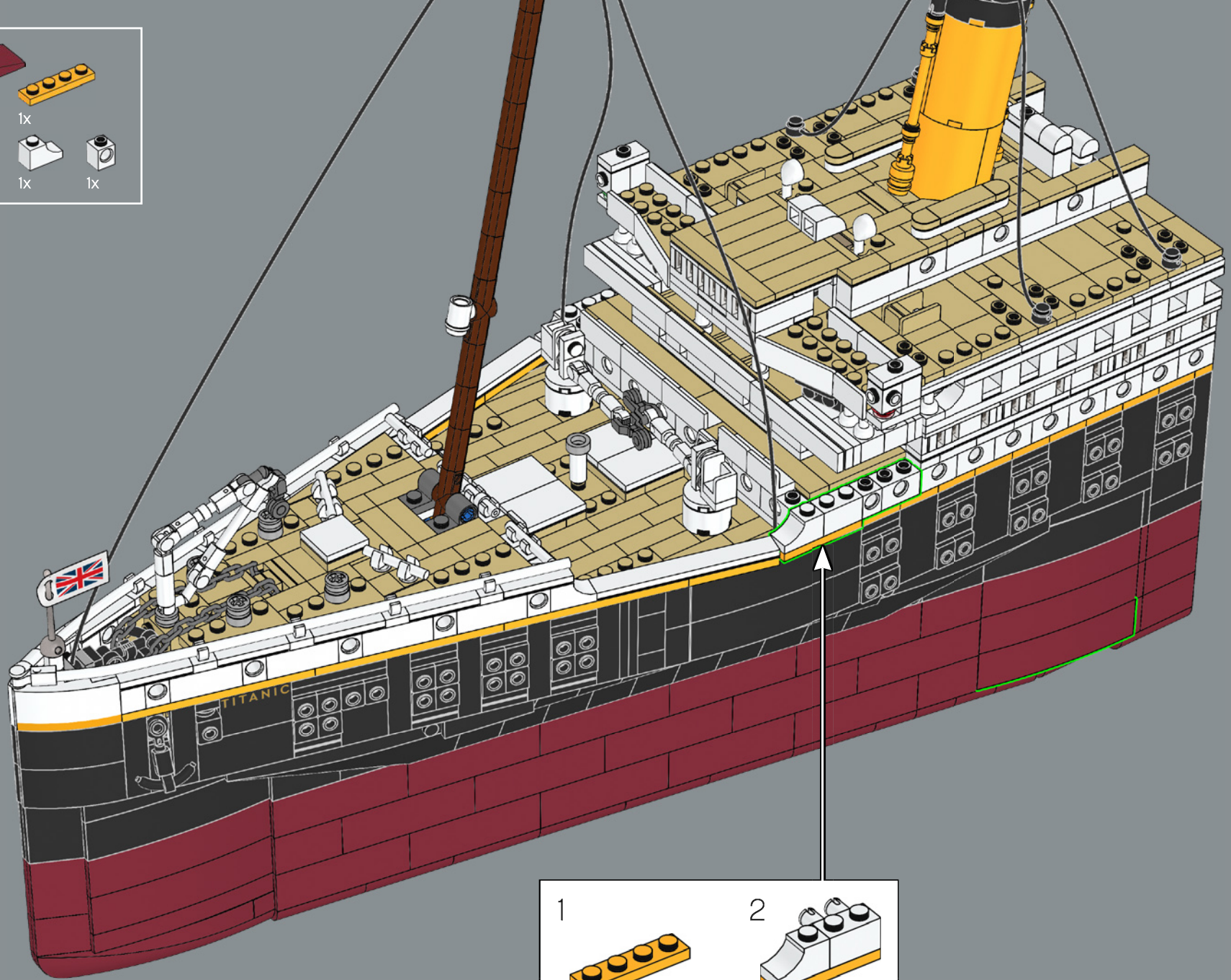

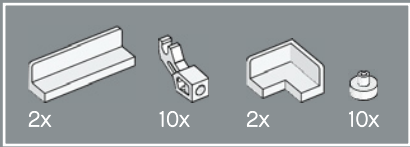

340

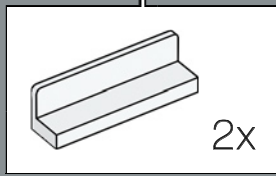
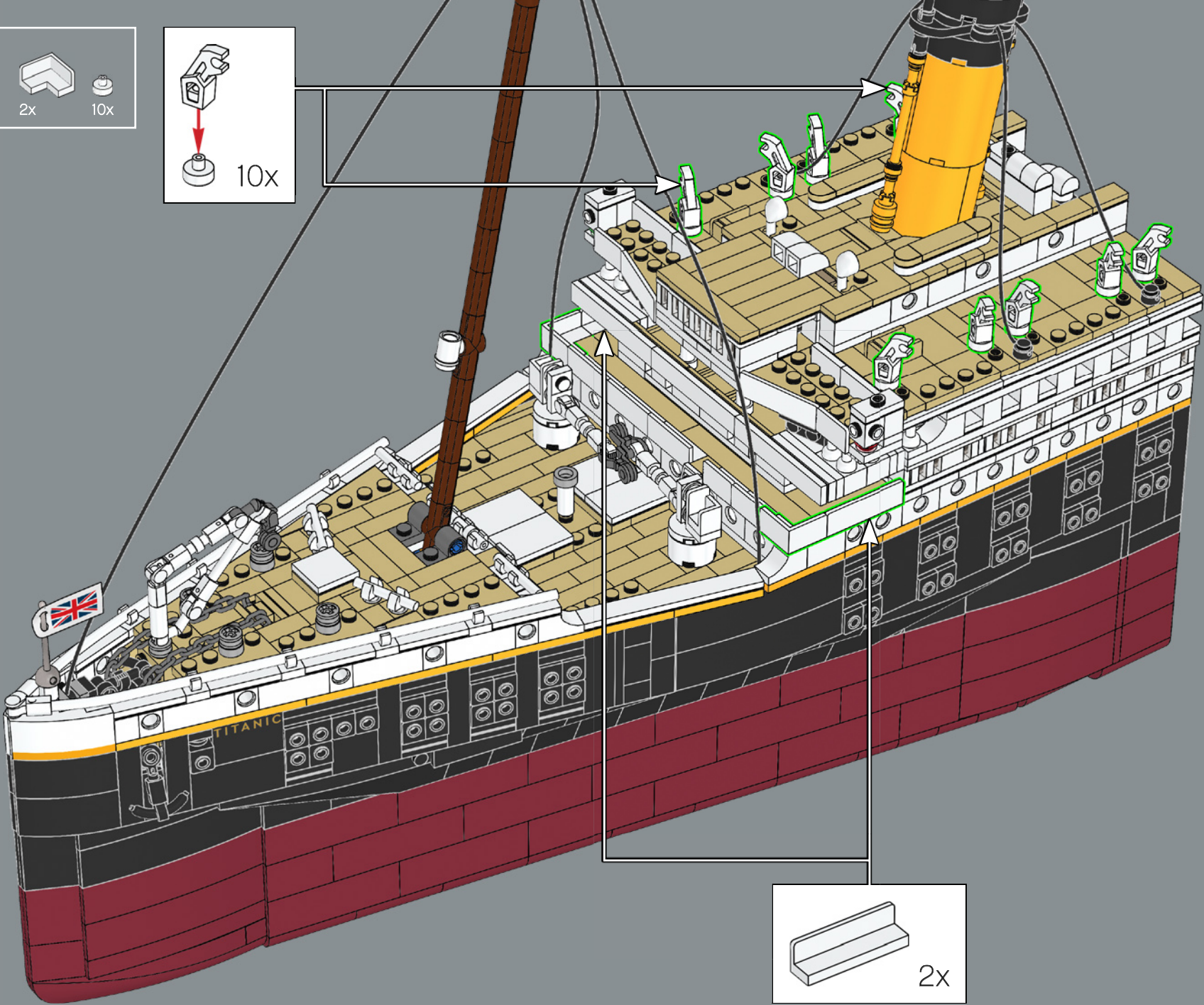
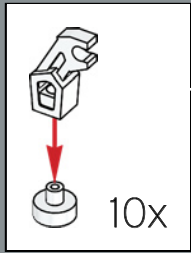





341

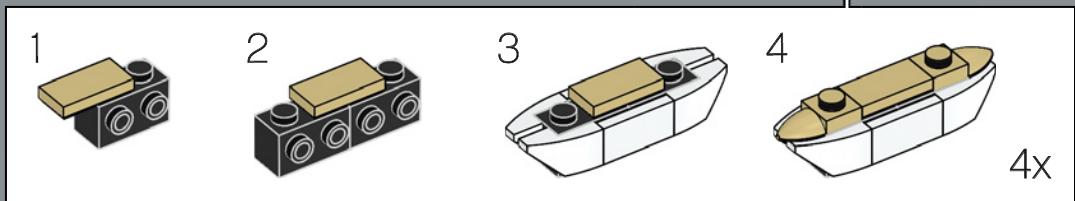
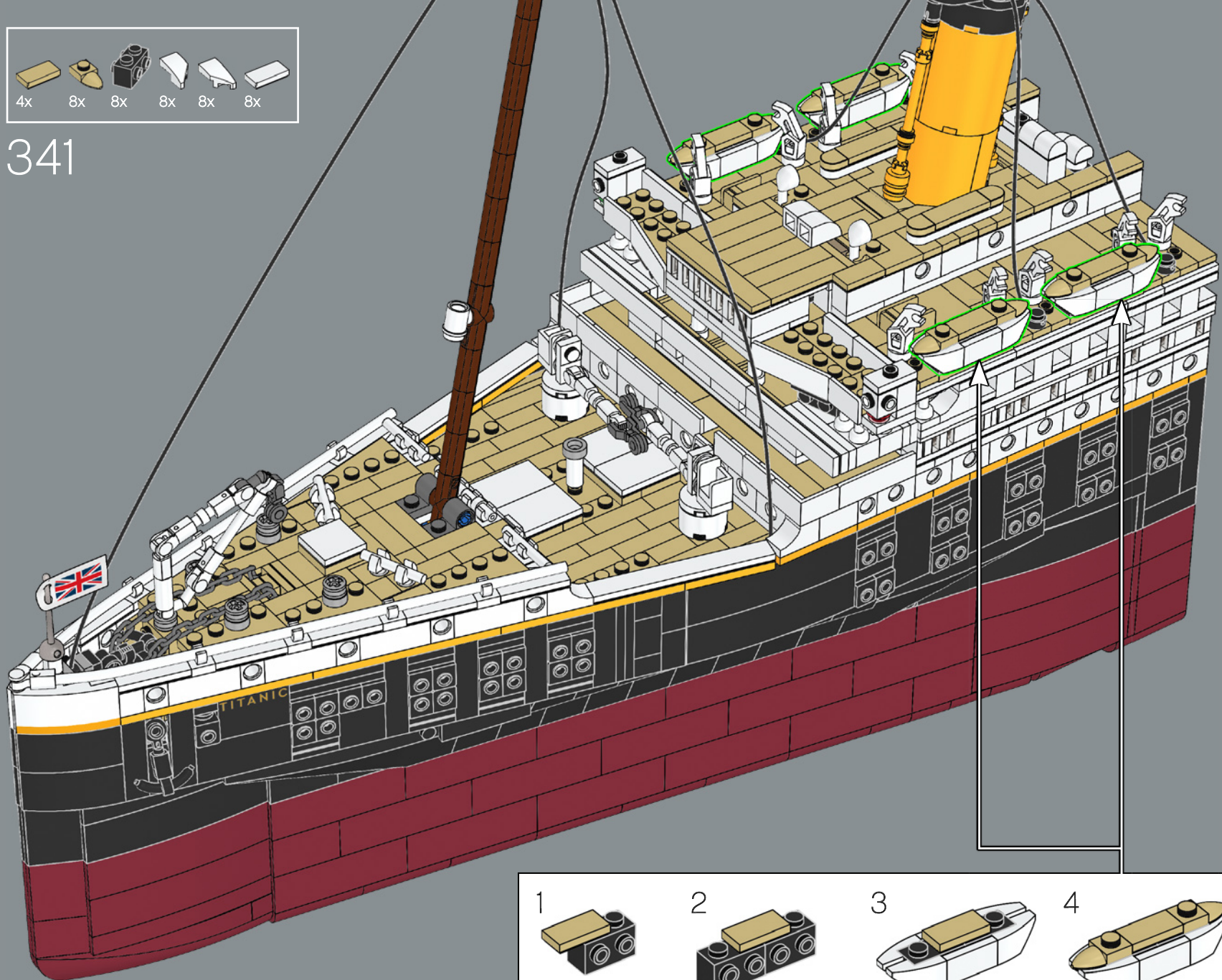

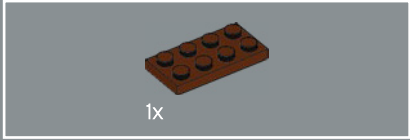
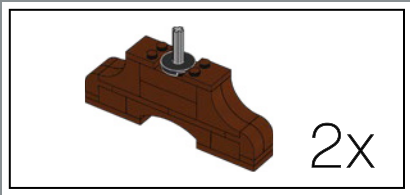

342

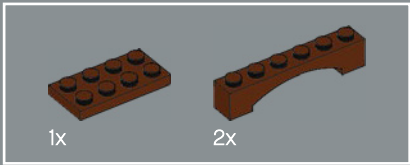
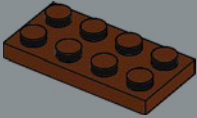

343

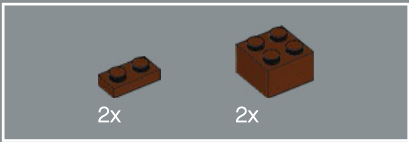
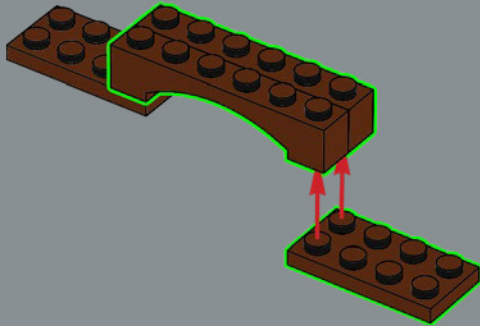

344

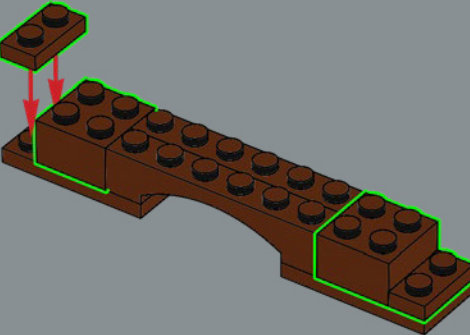

345

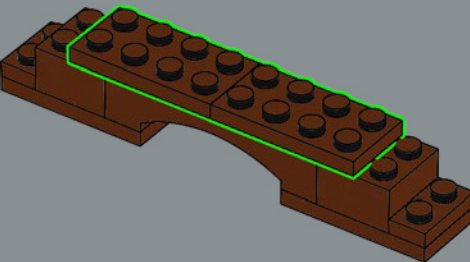

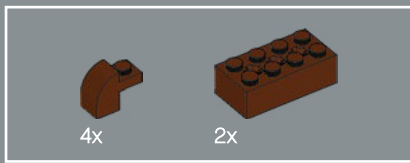

346

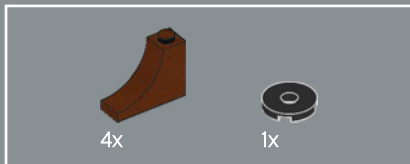
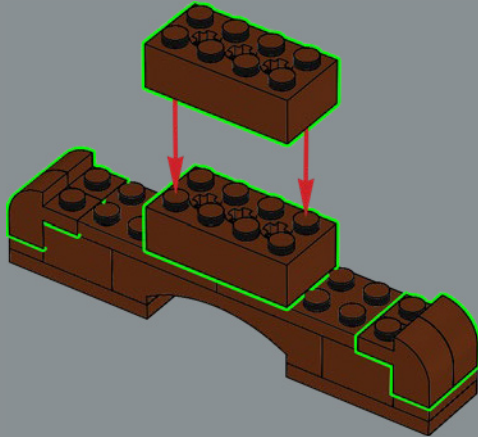

347

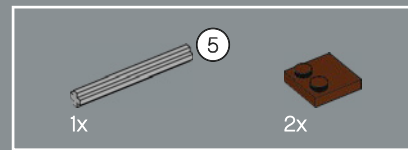
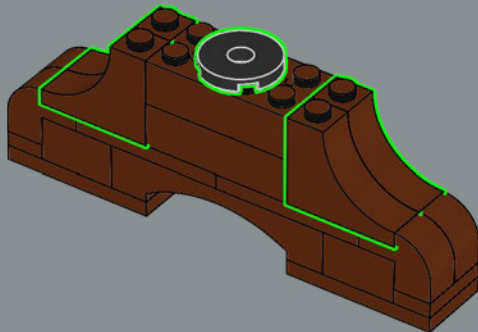

348

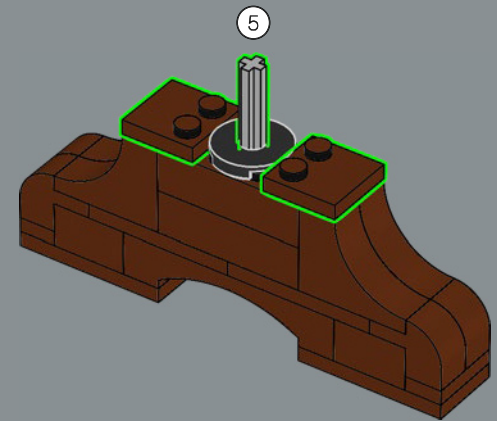

2x

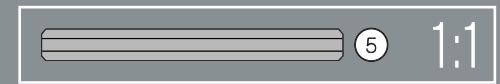

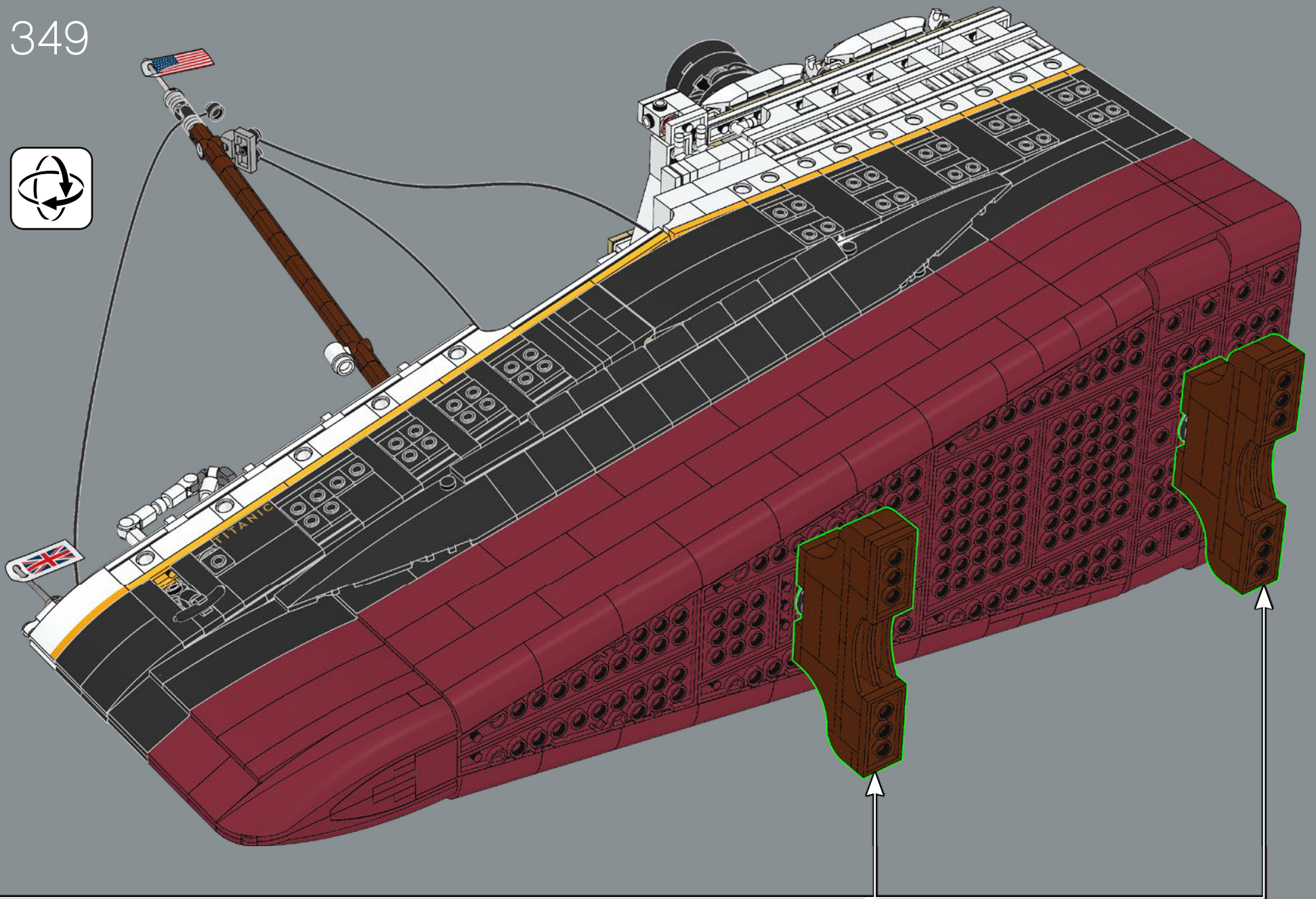

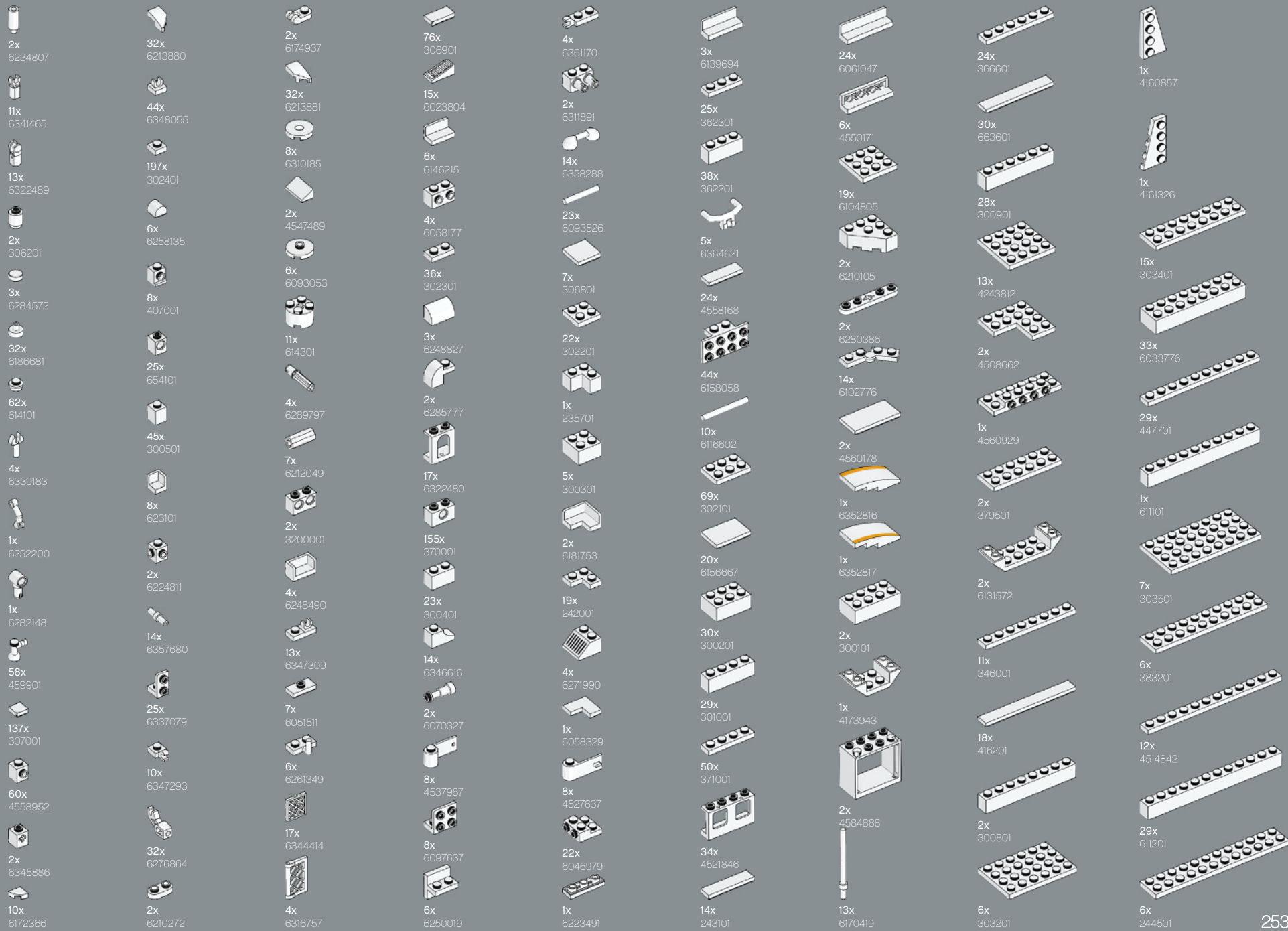

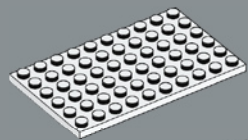

5x  
4528341

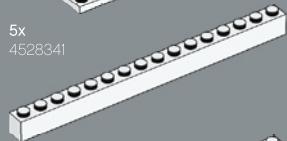

6x  
246501



13x  
4119227



2x  
6365707

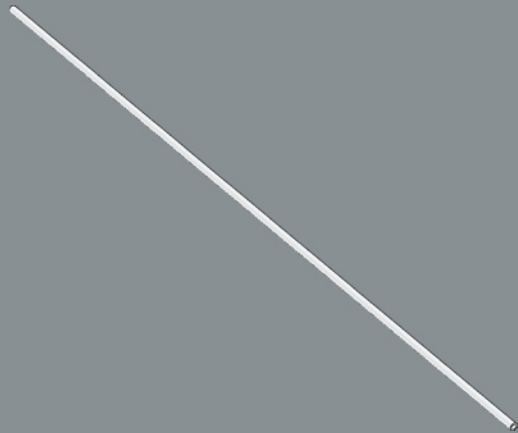

1x  
6364683



1x  
6370720

- 4x 6353196
- 44x 4118793
- 83x 6360078
- 2x 4113915
- 5x 4179771
- 54x 4125253
- 10x 4516055
- 20x 4159553
- 2x 4612603
- 2x 6357613
- 32x 4224793
- 4x 6355727
- 6x 6351413
- 14x 6352222
- 8x 6177890
- 8x 6177891

- 4x 4624086
- 4x 6034929
- 4x 6232037
- 50x 4218749
- 41x 6092587
- 2x 6338180
- 4x 6148262
- 6x 4109995
- 6x 6146221
- 2x 6024495
- 13x 4205107
- 1x 6063943
- 2x 6294481
- 2x 6103001
- 153x 4114026
- 21x 4113917

- 1x 4565387
- 39x 4185177
- 44x 6221467
- 44x 4114084
- 47x 6173057
- 18x 4114077
- 16x 6265572
- 4x 6211975
- 96x 6131896
- 14x 4121921
- 2x 4624088
- 34x 6211966
- 2x 6318084
- 8x 4118790
- 9x 6175367

- 2x 4500453
- 5x 4666999
- 2x 4113233
- 12x 4550324
- 26x 6257600
- 2x 6195544
- 2x 6115031
- 2x 4208072
- 33x 4114309
- 53x 6122047
- 8x 6351905
- 2x 4112982
- 10x 4157277

- 3x 6331158
- 4x 4113993
- 5x 4181134
- 49x 4114324
- 11x 4544139
- 12x 4159774
- 2x 4114001
- 2x 4125217
- 2x 4166138
- 3x 4509897

- 4x 6070501
- 6x 6093864
- 6x 6284574
- 2x 306221
- 8x 654121
- 10x 6345429
- 1x 6210269
- 46x 4142865
- 2x 6168634
- 4x 6019155
- 1x 6265697
- 22x 302321
- 2x 245821
- 2x 6313831

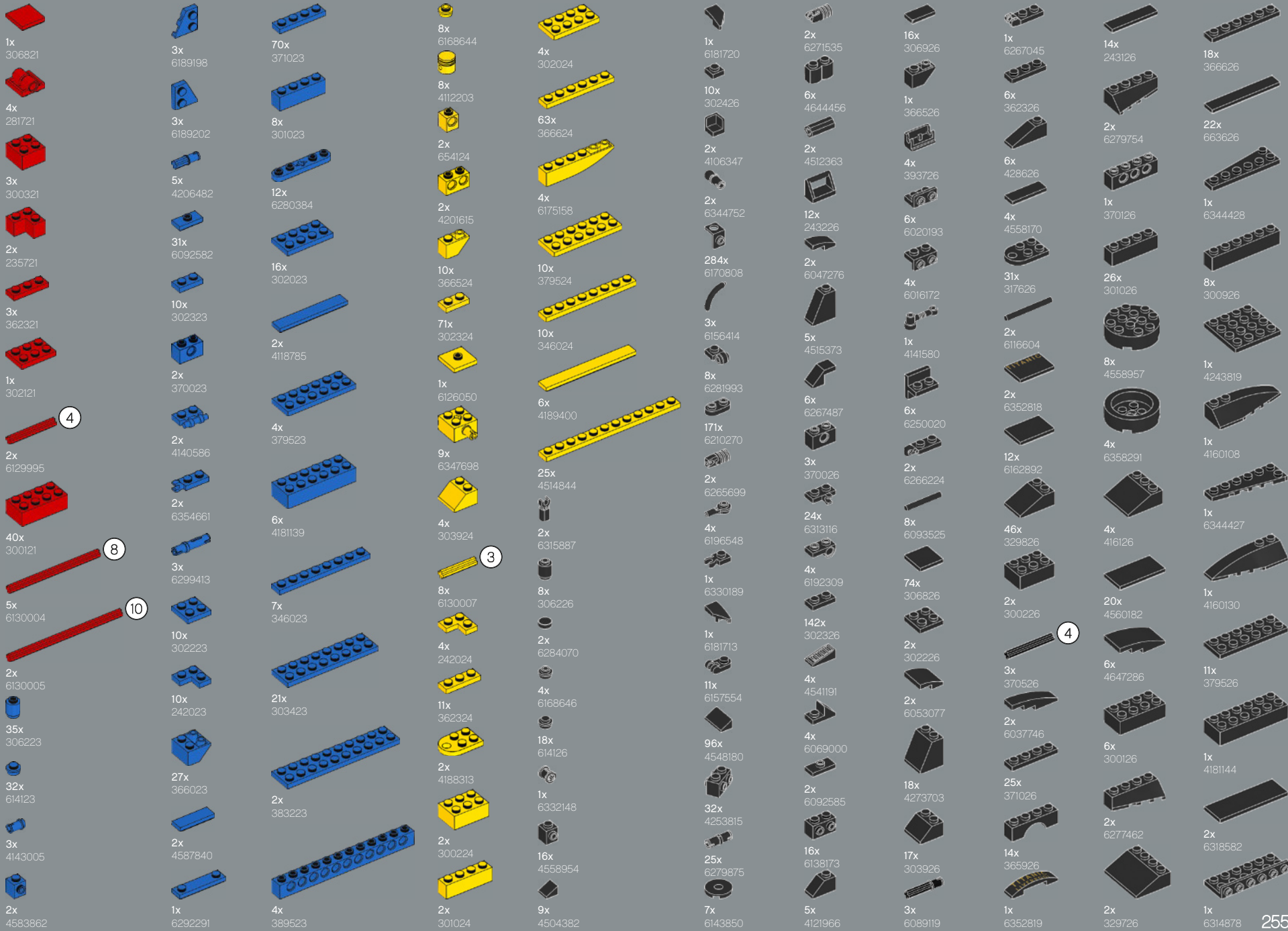

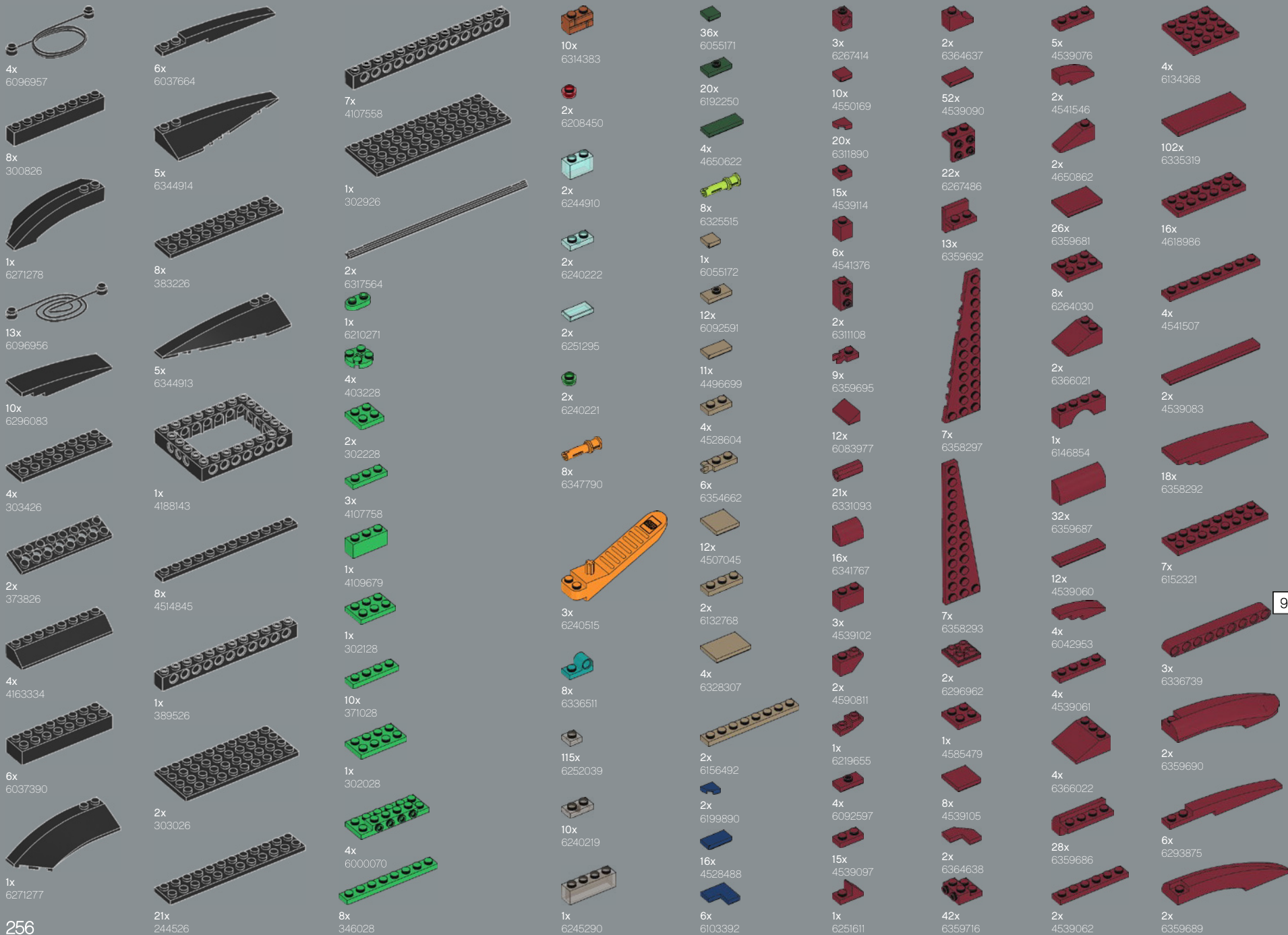

4x  
6096957

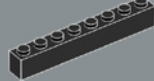

8x  
300826



1x  
6271278



13x  
6096956



10x  
6296083



4x  
303426



2x  
373826

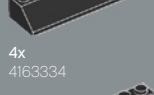

4x  
4163334



6x  
6037390



1x  
6271277



6x  
6037664

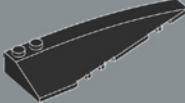

5x  
6344914

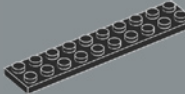

8x  
383226



5x  
6344913

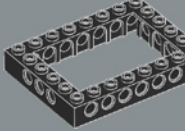

1x  
4188143



8x  
4514845



1x  
389526

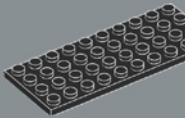

2x  
303026

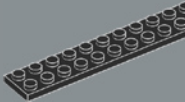

21x  
244526



7x  
4107558

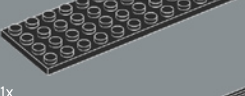

1x  
302926



2x  
6317564



1x  
6210271



4x  
403228



2x  
302228



3x  
4107758



1x  
4109679



1x  
302128



10x  
371028



1x  
302028



4x  
6000070



8x  
346028



10x  
6314383



2x  
6208450



2x  
6244910



2x  
6240222



2x  
6251295



2x  
6240221



8x  
6347790



3x  
6240515



115x  
6252039



10x  
6240219



1x  
6245290



36x  
6055171



20x  
6192250



4x  
4650622



8x  
6325515



1x  
6055172



12x  
6092591



11x  
4496699



4x  
4528604



6x  
6354662



12x  
4507045



2x  
6132768



4x  
6328307



2x  
6156492



2x  
6199890



16x  
4528488



3x  
6267414



10x  
4550169



20x  
6311890



15x  
4539114



6x  
4541376



2x  
6311108



9x  
6359695



12x  
6083977



21x  
6331093



16x  
6341767



3x  
4539102



2x  
4590811



1x  
6219655



4x  
6092597



15x  
4539097



2x  
6364637



52x  
4539090



22x  
6267486



13x  
6359692



7x  
6358297



7x  
6358293



2x  
6296962



1x  
4585479



8x  
4539105



2x  
6364638



42x  
6359716



5x  
4539076



2x  
4541546



2x  
4650862



26x  
6359681



8x  
6264030



2x  
6366021



1x  
6146854



32x  
6359687



12x  
4539060



4x  
6042953



4x  
4539061



4x  
6366022



28x  
6359686



2x  
4539062

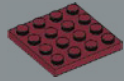

4x  
6134368



102x  
6335319

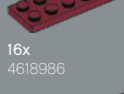

16x  
4618986

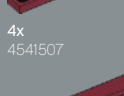

4x  
4541507

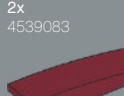

2x  
4539083



18x  
6358292

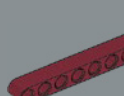

7x  
6152321

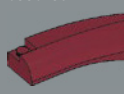

3x  
6336739

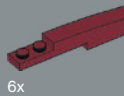

2x  
6359690



6x  
6293875



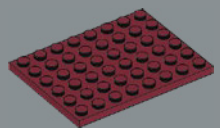

11x  
6028115

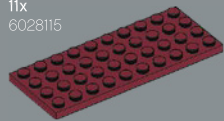

8x  
6186106



8x  
6245265



16x  
6134252



8x  
6223719



16x  
6331261



6x  
6073040



6x  
6028736



91x  
6097503



16x  
6358295



16x  
6020073



4x  
6359223



12x  
6020074



9x  
6192205

6x  
4211183



19x  
4216581



1x  
6170813



2x  
6149677



12x  
4221744



26x  
4211288



46x  
4225469



4x  
6325717



29x  
4531751



2x  
4211222



1x  
4211252



14x  
6365885



105x  
4211150



24x  
6335567



1x  
4211151



10x  
6365884



24x  
4645103



39x  
6236915



20x  
6196221



30x  
4211210



10x  
6365883



5x  
6333110



6x  
4211220



20x  
4211152



24x  
6133833



9x  
6172636



30x  
4211186



14x  
6365882



1x  
4221590



18x  
4211193



12x  
4655611



1x  
4216615



6x  
6313736

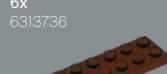

2x  
4211211



2x  
4222627



1x  
6338230

88x  
4211412

23x  
6258831

7x  
6172165

1x  
4211483

3x  
4558953

12x  
4211399

2x  
6225242

2x  
6345639

8x  
6335378

8x  
4211375

8x  
4211375

4x  
4568637

2x  
6352979

2x  
6352983

1x  
6352986

1x  
6352997

1x  
6353001

155x  
4550325

2x  
6372076

16x  
6093859

4x  
6327412

9x  
6338165

2x  
4211564

20x  
4211398

8x  
4211414

8x  
4211440

10x  
6206249

1x  
6326078

8x  
6146300

8x  
6146300

8x  
4211363

4x  
4211494

2x  
4211614

4x  
6117967

6x  
4654580

8x  
4211609

4x  
6337268

4x  
6078211

4x  
6198932

4x  
4667578

4x  
4211461

4x  
4211632

4x  
6321743

1x  
4208988

1x  
4208988

8x  
4211397

46x  
6212077

6x  
6007894

6x  
4234535

4x  
4211815

4x  
6078212

8x  
6195471

1x  
6346487

4x  
6326483

1x  
6304930

15x  
6211969

8x  
4211419

11x  
4211773

30x  
4211396

1x  
4211386

9x  
4211394

1x  
4211441

2x  
4211445

26x  
4211636

8x  
6230229

2x  
4211361

2x  
4211395

8x  
4211385

6x  
4211639

4x  
6256117

8x  
6105964

6x  
4211393

16x  
4211438

2x  
4612621

2x  
4211837

2x  
4527174

4x  
6015349

35x  
4211452

13x  
4211795

4x  
6225219

4x  
4211425

2x  
4211442

2x  
4211442

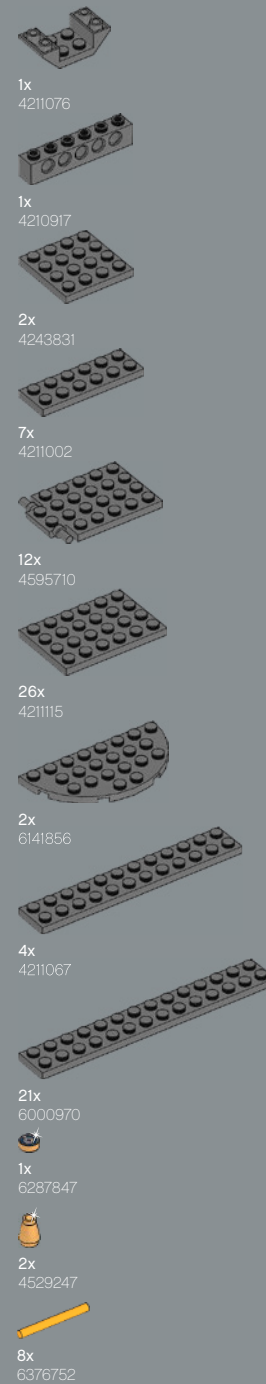
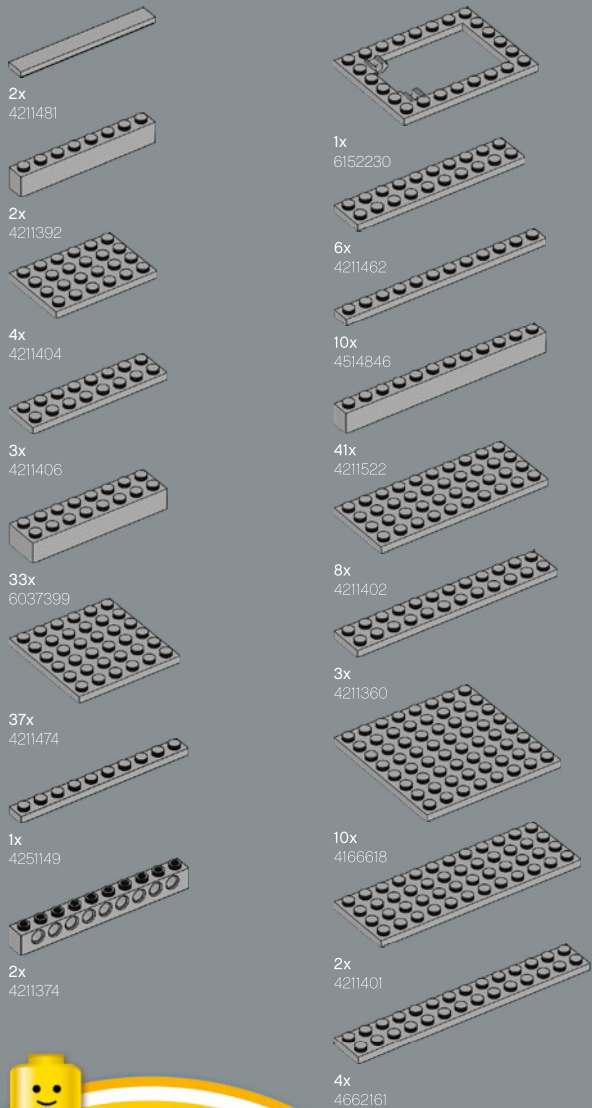

**Customer Service**  
**Kundenservice**  
**Service Consommateurs**  
**Servicio Al Consumidor**

[LEGO.com/service](http://LEGO.com/service) or dial





# FEEDBACK AND WIN



## FEEDBACK AND WIN

Your feedback will help shape the future development of this product series.

Please visit:

## FEEDBACK UND GEWINNEN

Dein Feedback trägt zur Weiterentwicklung dieser Produktreihe bei.

Geh auf:

## COMMENTEZ ET GAGNEZ

Vos commentaires nous aideront à concevoir les futurs produits de cette gamme.

Rendez-vous sur :

## COMENTA Y GANA

Tu opinión nos ayudará a dar forma al desarrollo de esta serie de productos en el futuro.

Visita:

## 反馈有奖

您的反馈将有助于我们在今后改进本系列产品。

请访问：

[LEGO.com/productfeedback](https://www.lego.com/productfeedback)

By completing, you will automatically enter a drawing to win a LEGO® set.

Terms & Conditions apply.

Durch Ausfüllen nimmst du automatisch an der Verlosung eines LEGO® Preises teil.

Es gelten die Teilnahmebedingungen.

En envoyant vos commentaires, vous serez automatiquement inscrit(e) à un tirage au sort qui vous permettra de remporter un prix LEGO®.

Offre soumise à conditions.

Al contestar, participarás automáticamente en el sorteo y podrás ganar un set LEGO®.

Sujeto a Términos y Condiciones.

完成我们的反馈调查，即可自动进入抽奖环节，赢取乐高®套装。

适用《条款和条件》。

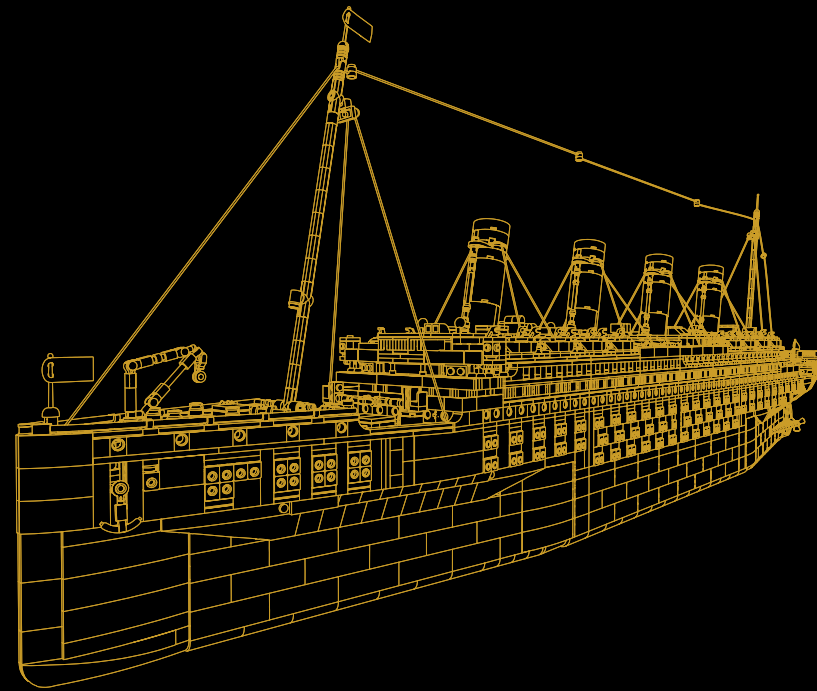

LEGO and the LEGO logo are trademarks of the LEGO Group. ©2021 The LEGO Group.