



Architecture

21037

LEGO® House

Billund, Denmark
Billund, Danmark
Billund (Dinamarca)



[LEGO.com/architecture/booklet](https://www.lego.com/architecture/booklet)

LEGO® House



"For my family and myself, the LEGO Group has always been much more than just a company and our products more than just products. I am very passionate about play and how children learn through playing with LEGO® bricks. This is essentially the LEGO idea and what the LEGO House is all about. It has been very exciting seeing this long-time dream of having one place where everyone can experience the LEGO idea come true."

Kjeld Kirk Kristiansen,
grandson of the founder and
current LEGO Group owner



Scan the QR code with your smartphone to see a video of Kjeld Kirk Kristiansen talking about the LEGO® House project

Home of the Brick



For many years, LEGO® employees and their guests enjoyed visiting the small museum the company had created in the converted house of the company's founder, Ole Kirk Kristiansen, in the heart of Billund.

All the visitors were thrilled to learn about the history of the company and experience the philosophy behind LEGO play, and many expressed the wish to be able to share this experience with a wider audience. It was this enthusiastic interest that sparked the dream of creating an actual LEGO experience center.

"The location here in Billund is important. We were founded here, and we want to help develop and create life in the town, making it attractive to both citizens and visitors."

Kjeld Kirk Kristiansen

From the very beginning, the ambition with LEGO® House was to create a unique and inspiring, hands-on and minds-on experience, where LEGO fans of all ages could learn all about the company and the endless play possibilities offered by LEGO bricks.

It was quickly agreed that the right location would be in the center of Billund. This is where the LEGO story started almost 90 years ago and the town still serves as the global headquarters of the LEGO Group. Then came the task of finding a partner who could design a distinctive building that would become an integral part of the LEGO House experience.



The original patent certificate for the LEGO® Brick from 1959.

Behind the Design

Bjarke Ingels, Founding Partner of BIG-Bjarke Ingels Group and architect of the LEGO® House, is not only a globally renowned architect, but also an enthusiastic LEGO fan. Before he and his team started working on the LEGO House project, they spent some time playing and building with LEGO bricks. They soon discovered that the systematic creativity of LEGO play often matched the way they approached an architectural task. They also found that the modularity of the LEGO brick inspired them in their work when designing the unique structure that would become the LEGO House.

"If BIG had been founded with the purpose of building only one single building, it would be the LEGO® House."

Bjarke Ingels





According to Ingels, the idea for the LEGO® House was to create “a cloud of interlocking LEGO bricks... a literal manifestation of the infinite possibilities of the LEGO brick.” 21 white bricks would be stacked on top of each other and be crowned by the Keystone, which would be inspired by the classic eight-knob LEGO brick.

These huge bricks will not only form internal spaces for LEGO House activities, but also create a covered public square and a series of interconnected terraces and playgrounds for people to investigate and enjoy. In this way, the LEGO House will be enjoyed both by fans who came to experience the LEGO story and by local citizens and visitors to the town of Billund.

"LEGO® House gives us the opportunity to show how children learn through LEGO play, and at the same time we tell the LEGO history in an involving way which reflects our values."

Kjeld Kirk Kristiansen





From Idea to Reality

The completed LEGO® House covers an area of almost 129,167 sq. ft. (12,000 m²), 91,493 sq. ft. – (8,500 m²) above ground and 36,597 sq. ft. (3,400 m²) of basement – and reaches 75.4 ft. (23 m) into the Billund skyline. It consists of four specially themed Experience Zones that offer the guests unique hands-on LEGO play experiences. There is also a historic section underground that presents the company's heritage and relates the story of the development of the LEGO products and Brand.

While the largest part of the building is reserved for paying guests, almost a quarter of the above-ground area of LEGO House – including most of the terraces, plus the café and shop – are open to everyone.

"LEGO® House is a super important project – not only to BIG and myself but to millions of people all over the world."

Bjarke Ingels



LEGO® House



« Pour ma famille et moi, le Groupe LEGO a toujours été beaucoup plus qu'une entreprise et nos produits beaucoup plus que des produits. Je suis passionné par le jeu et par la façon dont les enfants apprennent avec les briques LEGO®. Ceci est essentiellement l'idée LEGO et la raison d'être de la LEGO House. La réalisation de ce vieux rêve d'avoir un lieu où tout le monde peut découvrir l'idée LEGO a été passionnante. »

Kjeld Kirk Kristiansen,
petit-fils du fondateur et
propriétaire actuel du Groupe LEGO



Scannez le code QR avec
votre téléphone intelligent pour
voir une vidéo de Kjeld Kirk
Kristiansen parler du projet de
la LEGO® House



La ville de la brique



Pendant de nombreuses années, les employés de LEGO® et leurs invités ont aimé visiter le petit musée que l'entreprise avait créé à Billund dans la maison transformée du fondateur, Ole Kirk Kristiansen.

Tous les visiteurs étaient fascinés d'apprendre l'histoire de l'entreprise et de découvrir la philosophie à l'origine du jeu LEGO, et beaucoup ont exprimé le souhait de partager cette expérience avec un public plus large. C'est cet enthousiasme qui a lancé le rêve de créer un vrai centre d'expérience LEGO.

« L'emplacement ici à Billund est important. L'entreprise a été fondée ici et nous voulons aider au développement et à la dynamisation de la ville, afin de la rendre attrayante pour les habitants et pour les visiteurs. »

Kjeld Kirk Kristiansen

Dès le début, l'ambition de la LEGO® House fut de créer une expérience interactive et intéressante, unique et inspirante, où les fans LEGO de tous les âges pourraient tout apprendre sur l'entreprise et découvrir les possibilités de jeu infinies qu'offrent les briques LEGO.

Il fut rapidement décidé que l'emplacement adéquat serait au centre de Billund. C'est là que l'histoire de LEGO a commencé il y a presque 90 ans et la ville accueille toujours le siège social mondial du Groupe LEGO. Vint ensuite la tâche de trouver un partenaire capable de créer un bâtiment distinctif qui deviendrait une partie intégrante de l'expérience de la LEGO House.

Le certificat original du brevet de la brique LEGO® de 1959.



L'origine du concept

Bjarke Ingels, partenaire fondateur du Groupe BIG-Bjarke Ingels et architecte de la LEGO® House, est non seulement un architecte de renommée mondiale mais aussi un grand fan de LEGO. Avant que lui et son équipe ne commencent à travailler sur le projet de la LEGO House, ils ont passé du temps à jouer et à construire avec les briques LEGO. Ils ont rapidement découvert que la créativité systématique du jeu LEGO correspondait souvent à la façon dont ils abordaient une tâche architecturale. Ils se sont également rendu compte que la modularité des briques LEGO les inspirait dans leur travail pour concevoir la structure unique qui allait devenir la LEGO House.

« Si BIG avait été fondé dans le but de construire un seul bâtiment, ce serait la LEGO® House. »

Bjarke Ingels





Selon Ingels, l'idée derrière la LEGO® House était de créer un « nuage de briques LEGO entrelacées... une manifestation littérale des possibilités infinies des briques LEGO ». Vingt et une briques blanches furent empilées les unes sur les autres et couronnées par la pièce maîtresse, inspirée de la brique LEGO classique à huit tenons.

Ces briques énormes forment non seulement des espaces internes pour les activités de la LEGO House, mais créent aussi une place publique couverte et une série de terrasses et d'aires de jeu interconnectées pour que les gens les découvrent et en profitent. De cette façon, les fans qui sont venus découvrir l'histoire de LEGO ainsi que les habitants et les visiteurs de la ville de Billund pourront apprécier la LEGO House.

« La LEGO® House nous donne la possibilité de montrer comment les enfants apprennent par le jeu LEGO tout en racontant l'histoire de LEGO d'une façon engageante qui reflète nos valeurs. »

Kjeld Kirk Kristiansen





De l'idée à la réalité

La LEGO® House terminée a une superficie de presque 12 000 m², soit 8 500 m² en surface et 3 400 m² sous le sol, et elle s'élève à 23 m dans le ciel de Billund. Elle est composée de quatre zones d'expériences qui offrent aux visiteurs des expériences de jeu LEGO interactives et uniques. Il y a aussi une section historique au sous-sol qui présente l'héritage de l'entreprise et raconte l'histoire du développement des produits et de la marque LEGO.

Si la plus grande partie du bâtiment est réservée aux clients payants, presque un quart de l'espace de la LEGO House en surface, y compris la plupart des terrasses ainsi que le café et la boutique, est ouvert à tous.

« La LEGO® House est un projet très important, non seulement pour BIG et moi-même, mais pour des millions de personnes dans le monde. »

Bjarke Ingels



LEGO® House



«Para mi familia y para mí, The LEGO Group ha sido siempre mucho más que una empresa, y nuestros productos, más que productos. Soy un apasionado del juego y de cómo los niños aprenden a través de los bricks LEGO®. Esa es, en esencia, la idea de LEGO y lo que LEGO House significa. Ha sido apasionante ver cómo este antiguo sueño de disponer de un lugar en el que todos puedan experimentar la idea de LEGO se ha hecho realidad».

Kjeld Kirk Kristiansen,
nieto del fundador
y actual propietario de The LEGO Group



Escanea este código QR con
tu smartphone para ver un
video de Kjeld Kirk Kristiansen
hablando acerca del proyecto
LEGO® House



El hogar del brick



Durante muchos años, los empleados de LEGO® y sus invitados pudieron disfrutar del pequeño museo que la empresa había creado en la casa reconvertida de su fundador, Ole Kirk Kristiansen, en el corazón de Billund.

A los visitantes les encantaba conocer la historia de la empresa y experimentar la filosofía en la que se basan los juguetes LEGO. Muchos expresaban su deseo de poder compartir esa experiencia con un público mayor. Fue ese interés entusiasta el que dio lugar al sueño de crear un verdadero centro interactivo LEGO.

«El hecho de que esté situada en Billund es importante. La empresa se fundó aquí, y queremos contribuir a desarrollar y crear vida en este lugar. Que sea atractivo tanto para sus ciudadanos como para los visitantes».

Kjeld Kirk Kristiansen

Desde el primer momento, lo que se pretendía con LEGO® House era crear un espacio interactivo, único e inspirador, para las manos y las mentes, en el que fans de LEGO de todas las edades pudieran conocer en detalle la empresa y las infinitas posibilidades de juego que ofrecen los bricks LEGO.

Pronto se acordó que su emplazamiento idóneo sería el centro de Billund. Se trata de la ciudad donde comenzó la historia de LEGO hace casi 90 años y todavía sirve de sede central a The LEGO Group. Después, vino la tarea de encontrar un socio que pudiera diseñar un edificio emblemático que se convirtiera en parte integral de la experiencia LEGO House.



El certificado original de patente del brick LEGO® (1959)

Detrás del diseño

Bjarke Ingels, socio fundador de BIG-Bjarke Ingels Group y arquitecto de LEGO® House, no es sólo un arquitecto de renombre internacional, sino también un entusiasta de LEGO. Antes de que él y su equipo se pusieran a trabajar en el proyecto LEGO House, pasaron un tiempo jugando y construyendo con bricks LEGO. Pronto descubrieron que la creatividad sistemática del juego con LEGO coincidía a menudo con su modo de abordar los trabajos de arquitectura. También se dieron cuenta de que la modularidad del brick LEGO les servía de inspiración para diseñar la singular estructura que se convertiría en LEGO House.

«Si BIG se hubiera fundado con el propósito de construir un único edificio, sería LEGO® House».

Bjarke Ingels





De acuerdo con Ingels, la idea para LEGO® House era crear «una nube de bricks LEGO entrelazados... una manifestación literal de las infinitas posibilidades del brick LEGO». De este modo, se apilarían, uno sobre otro, 21 bricks blancos, coronados por la piedra clave, que estaría inspirada en el clásico brick LEGO de ocho espigas.

Estos enormes bricks no sólo forman espacios interiores para albergar las actividades de LEGO House, sino que dan lugar también a una plaza pública cubierta y una serie de terrazas y zonas de juego interconectadas donde la gente puede investigar y divertirse. De este modo, LEGO House puede ser disfrutado tanto por fans deseosos de experimentar la historia de LEGO como por los propios habitantes de Billund y quienes visitan la ciudad.

«LEGO® House nos brinda la oportunidad de demostrar cómo aprenden los niños cuando juegan con LEGO y, al mismo tiempo, contar la historia de LEGO de un modo participativo que refleja nuestros valores».

Kjeld Kirk Kristiansen





De la idea a la realidad

En total, LEGO® House abarca un área de casi 12.000 m² (8.500 m² sobre el piso y 3.400 m² de sótano), alcanzando una altura de 23 m sobre el horizonte de Billund. Consta de cuatro zonas interactivas temáticas que ofrecen a los visitantes diferentes experiencias prácticas de juego con LEGO. También existe una sección histórica en el sótano que presenta el legado de la empresa y narra la historia del desarrollo de los productos y la marca LEGO.

Aunque la mayor parte del edificio está reservada para los visitantes que abonan su entrada, casi una cuarta parte de LEGO House a partir de la planta baja se encuentra abierta al público en general, lo que incluye la mayor parte de las terrazas, además de la cafetería y la tienda.

«LEGO® House es un proyecto superimportante, no sólo para BIG y para mí mismo, sino para millones de personas de todo el mundo».

Bjarke Ingels



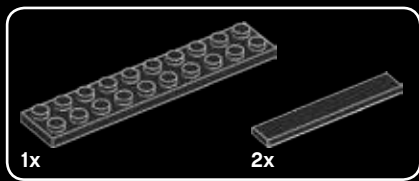
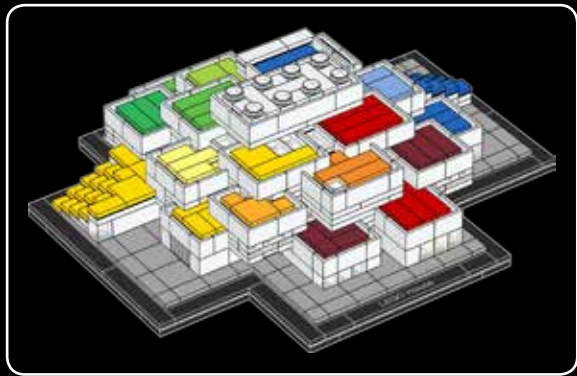

1

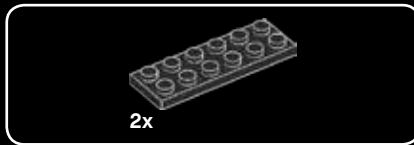
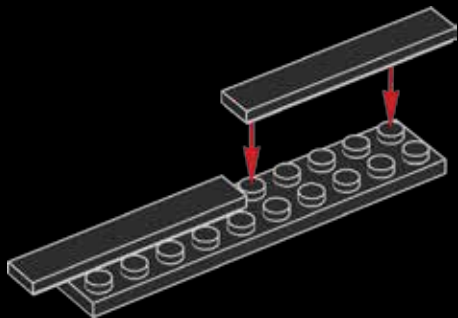

2

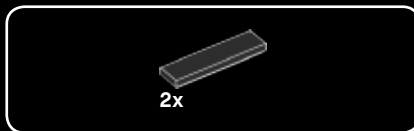
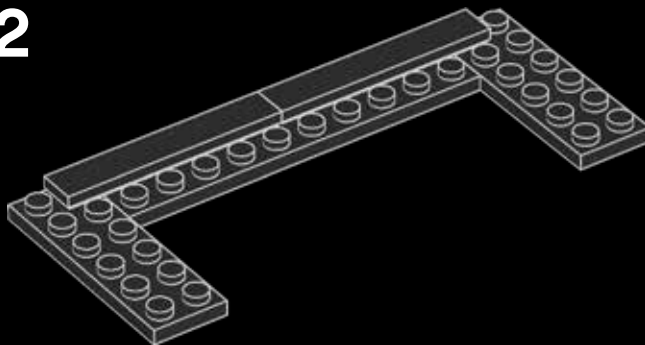

3

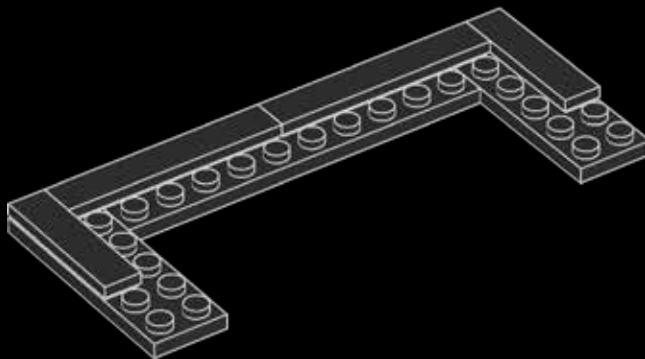

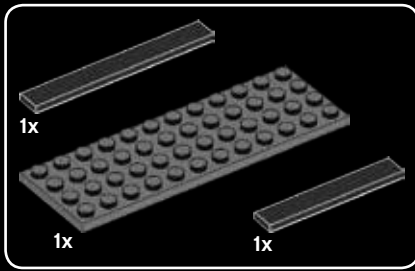

4

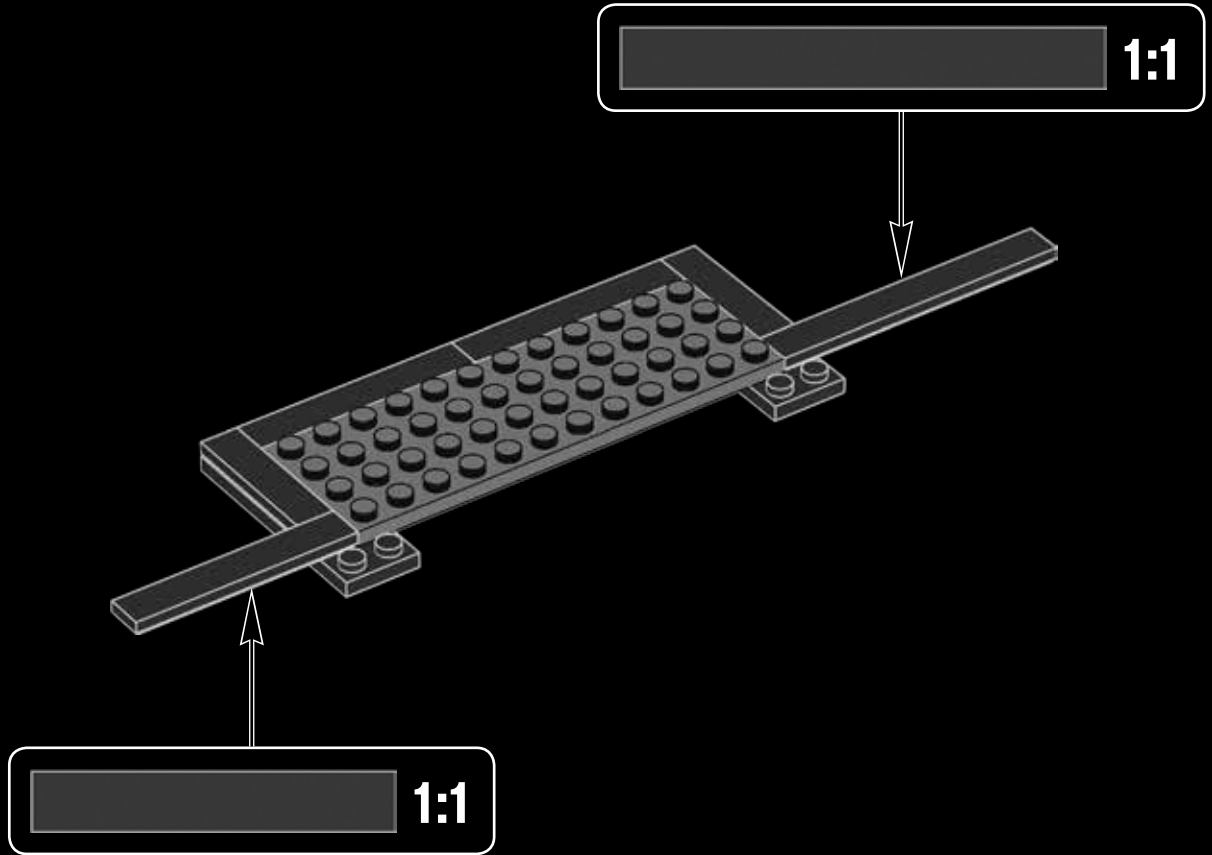

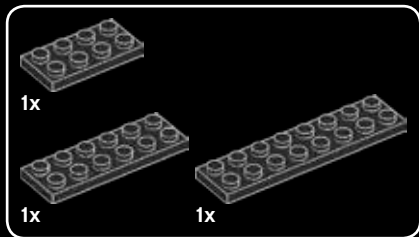

5

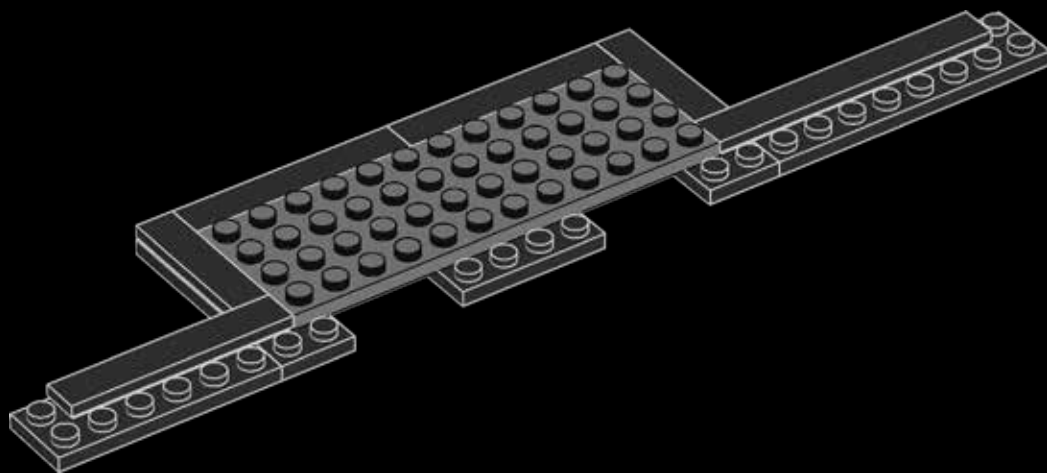

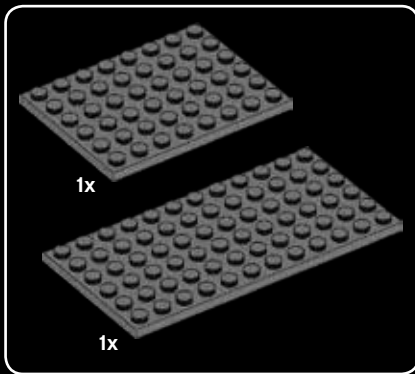

6

The lower deck of the basement is made up of 3,336 tons (1,390 cubic meters) of poured concrete.

La partie inférieure du sous-sol est fabriquée avec 1 390 m³ de béton coulé.

La plataforma inferior del sótano está formada por 3.336 toneladas (1.390 m³) de concreto vertido.

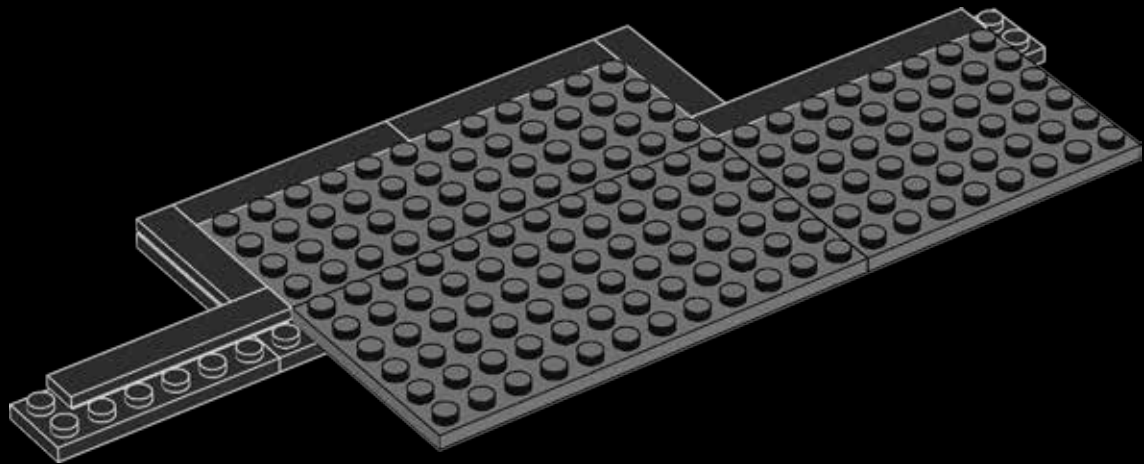

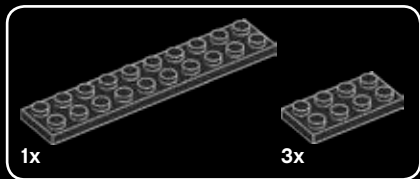

7

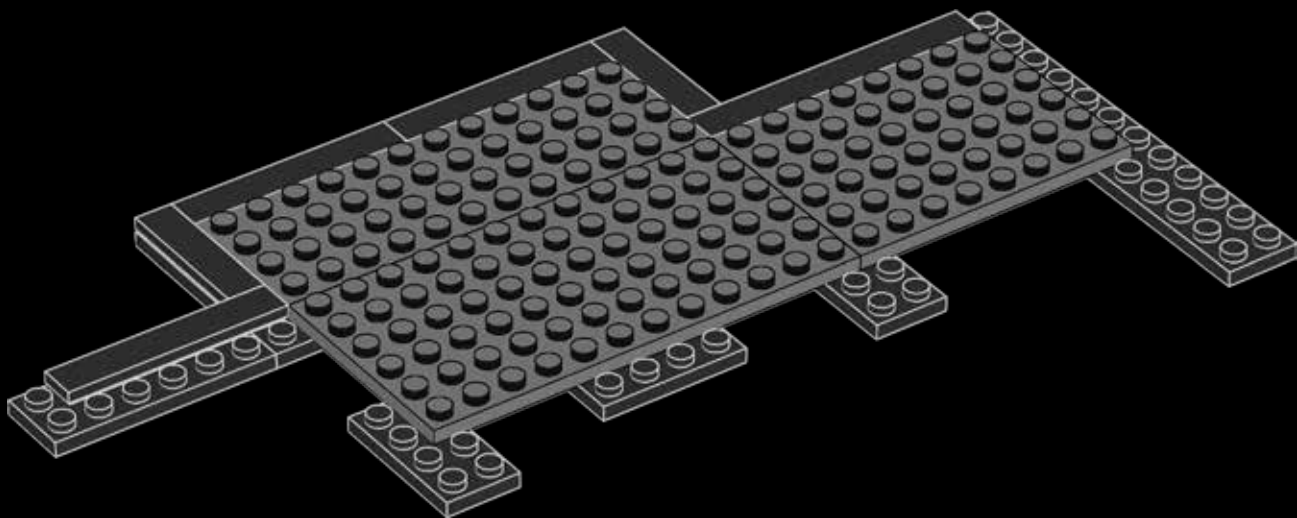

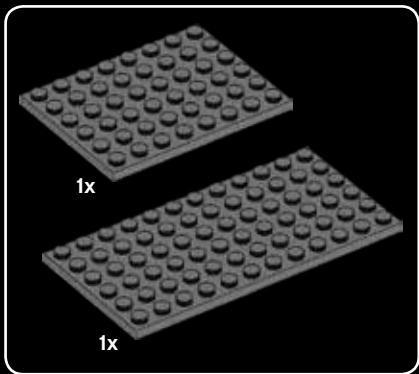

8

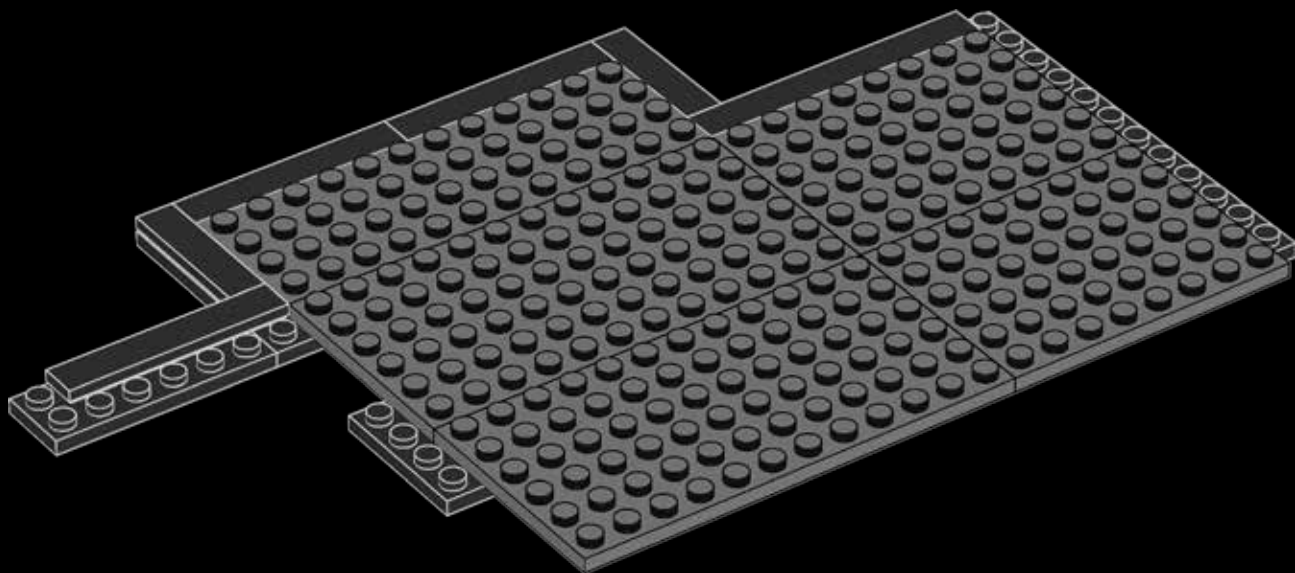

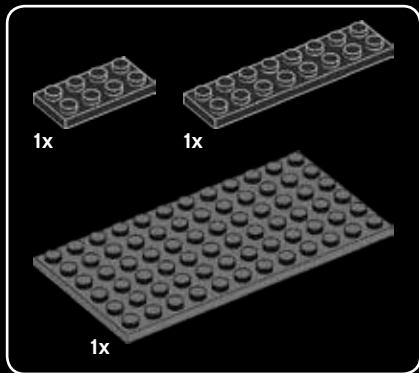

9

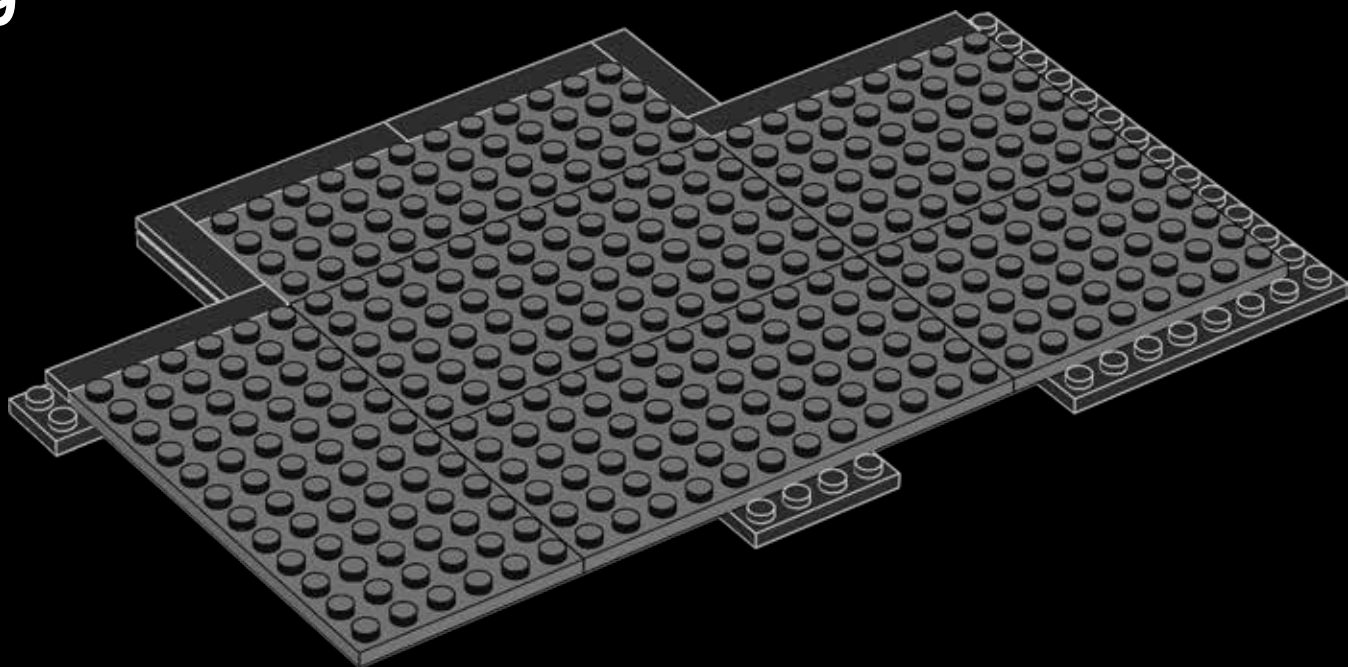

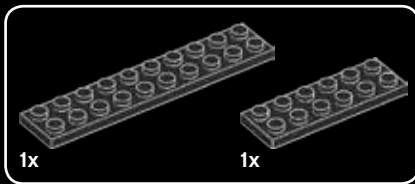

10

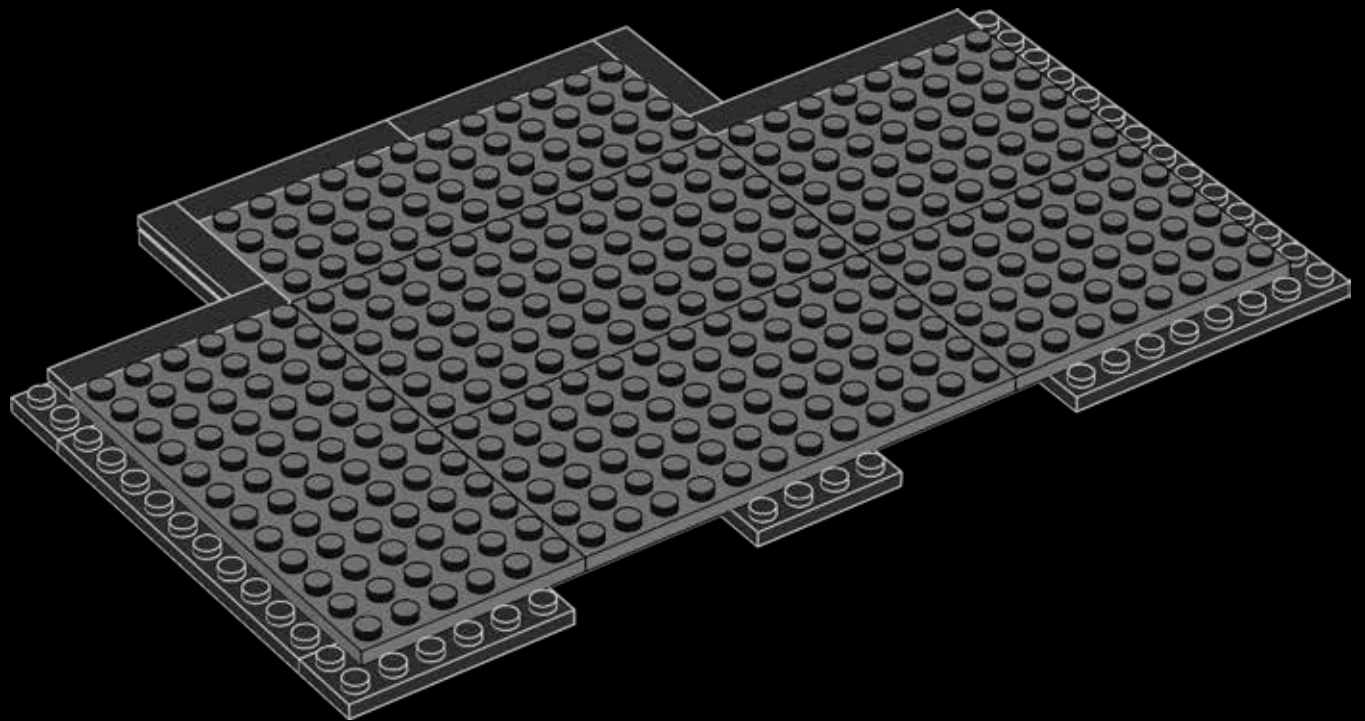

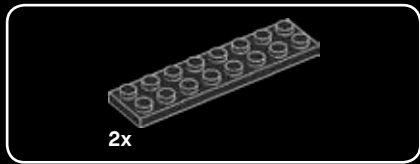

11

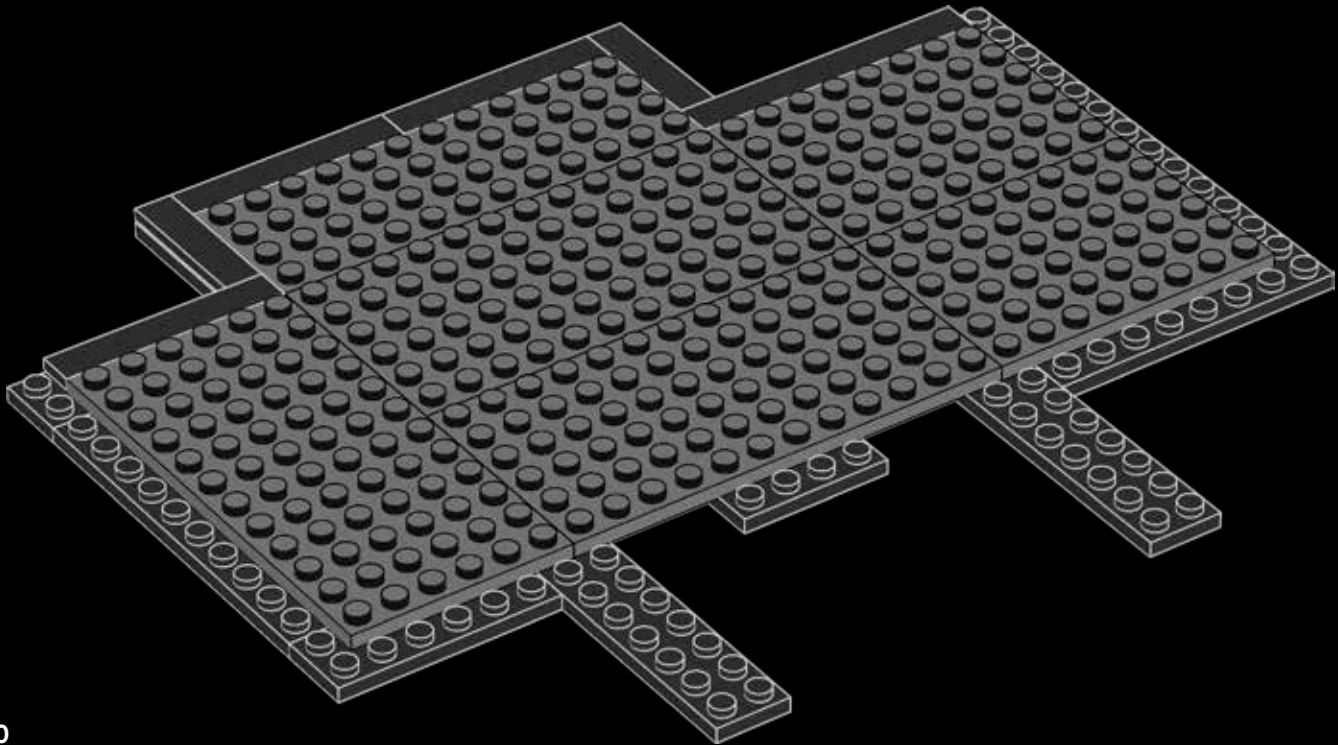

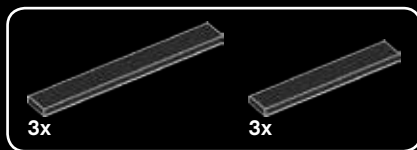

12

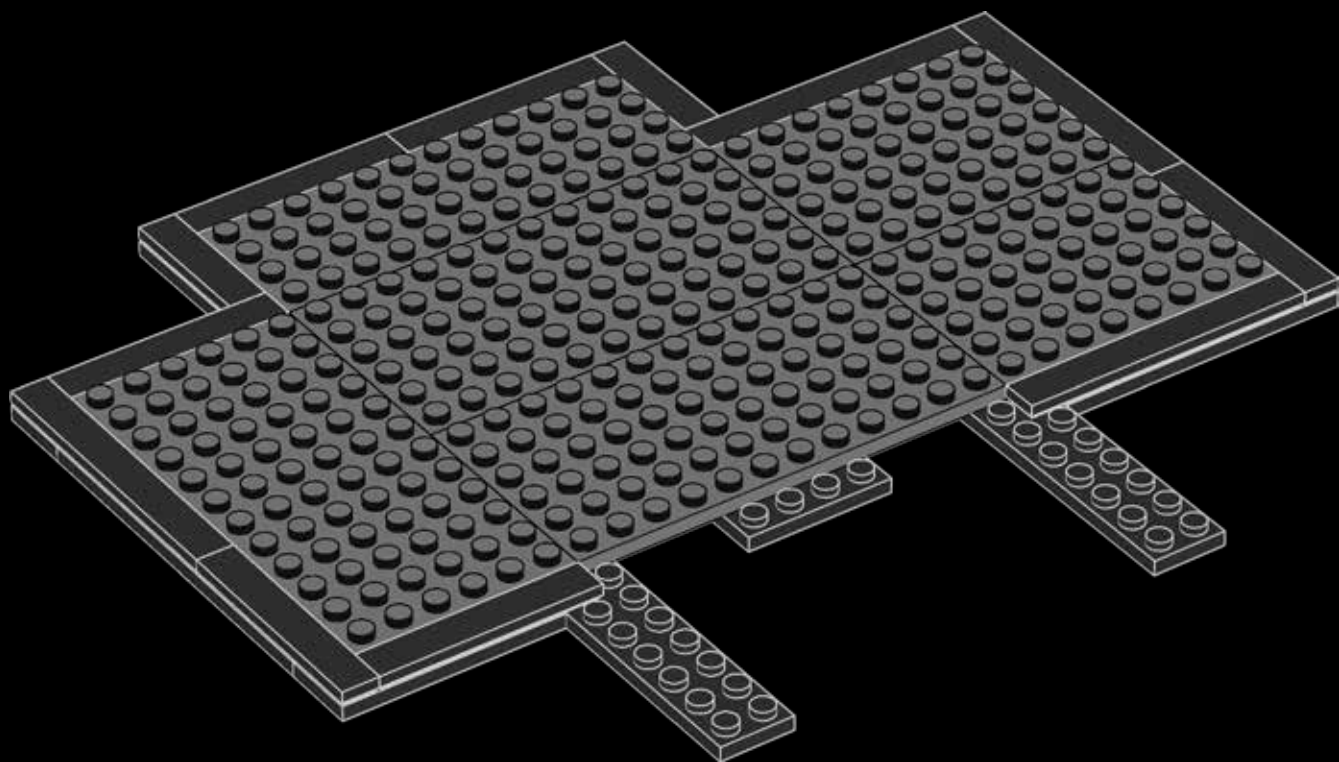

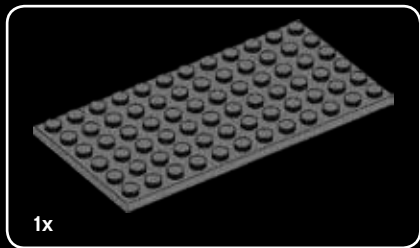

13

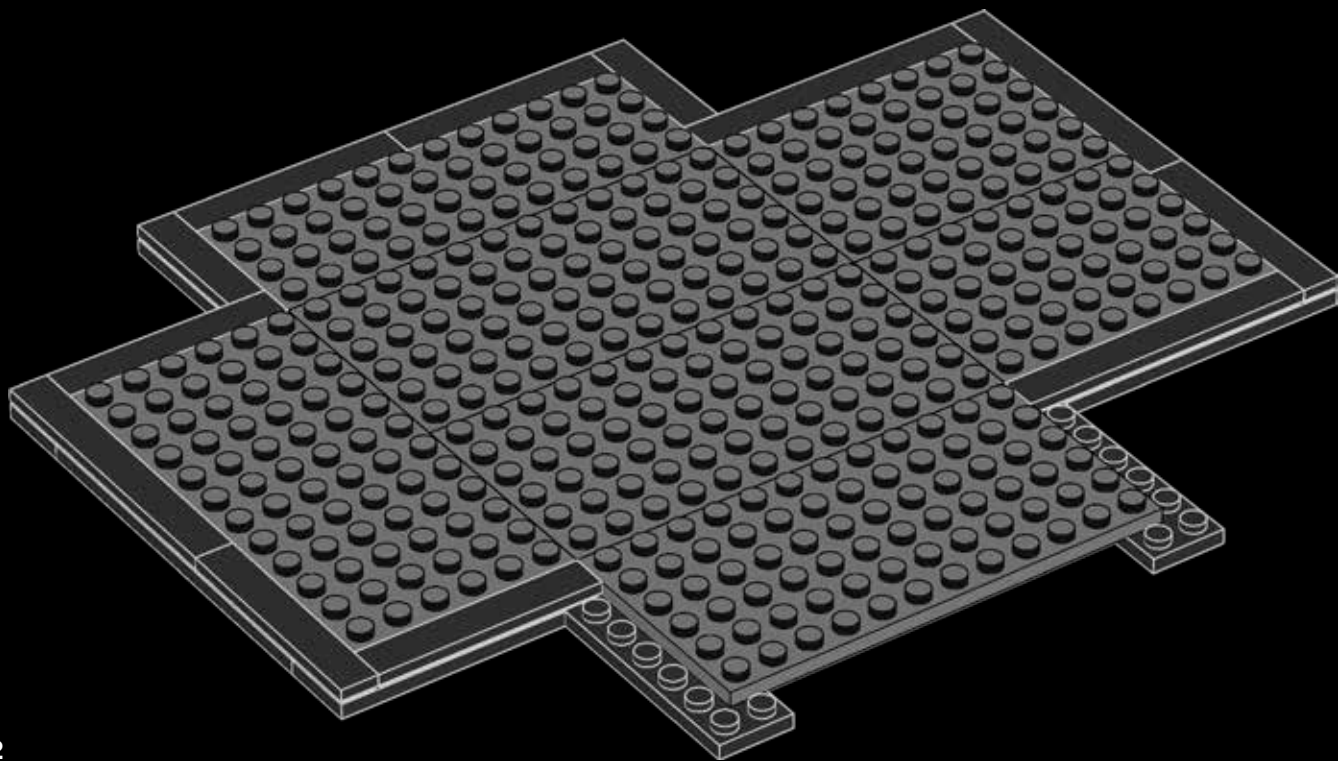

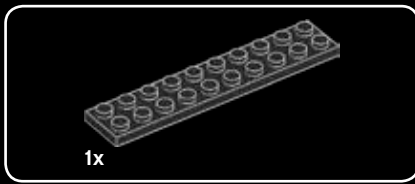

14

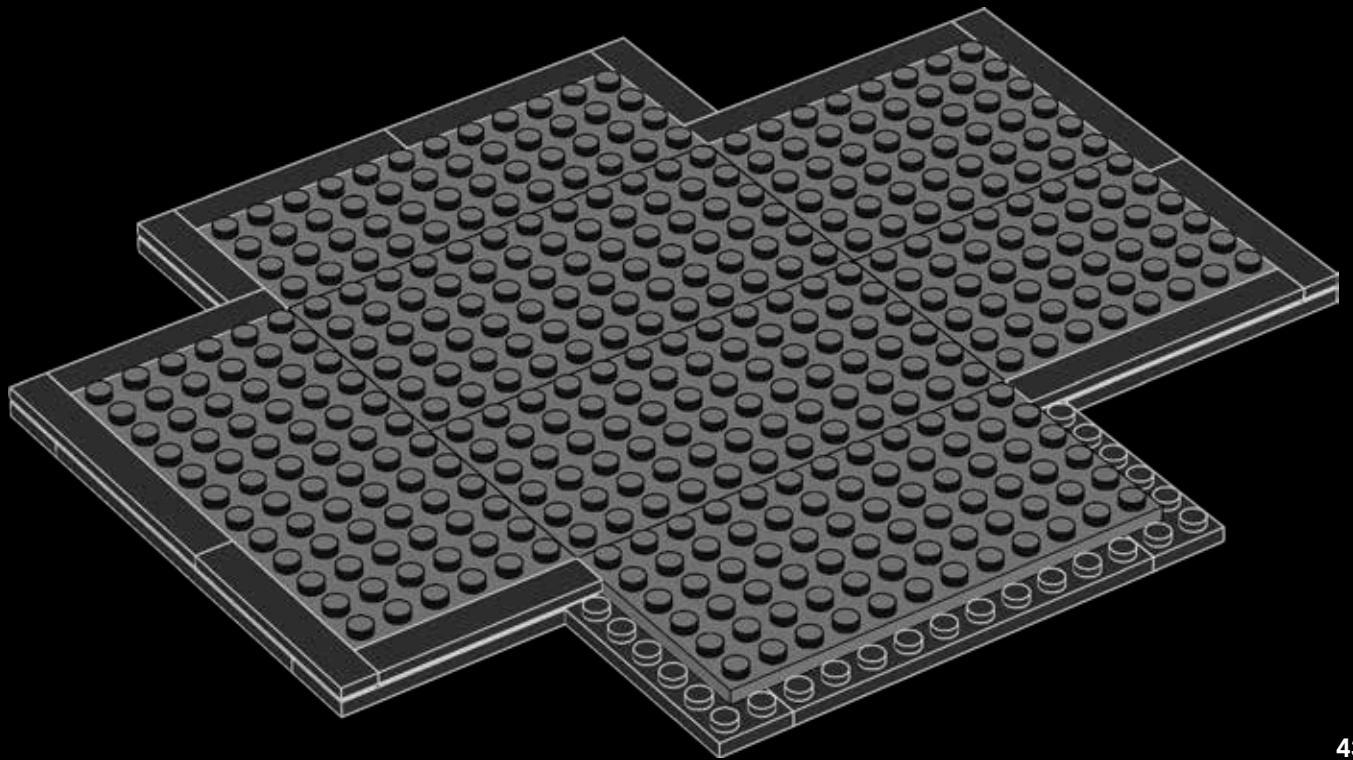

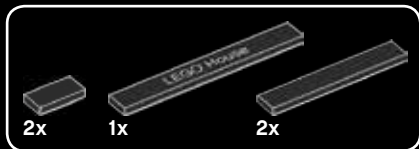

15

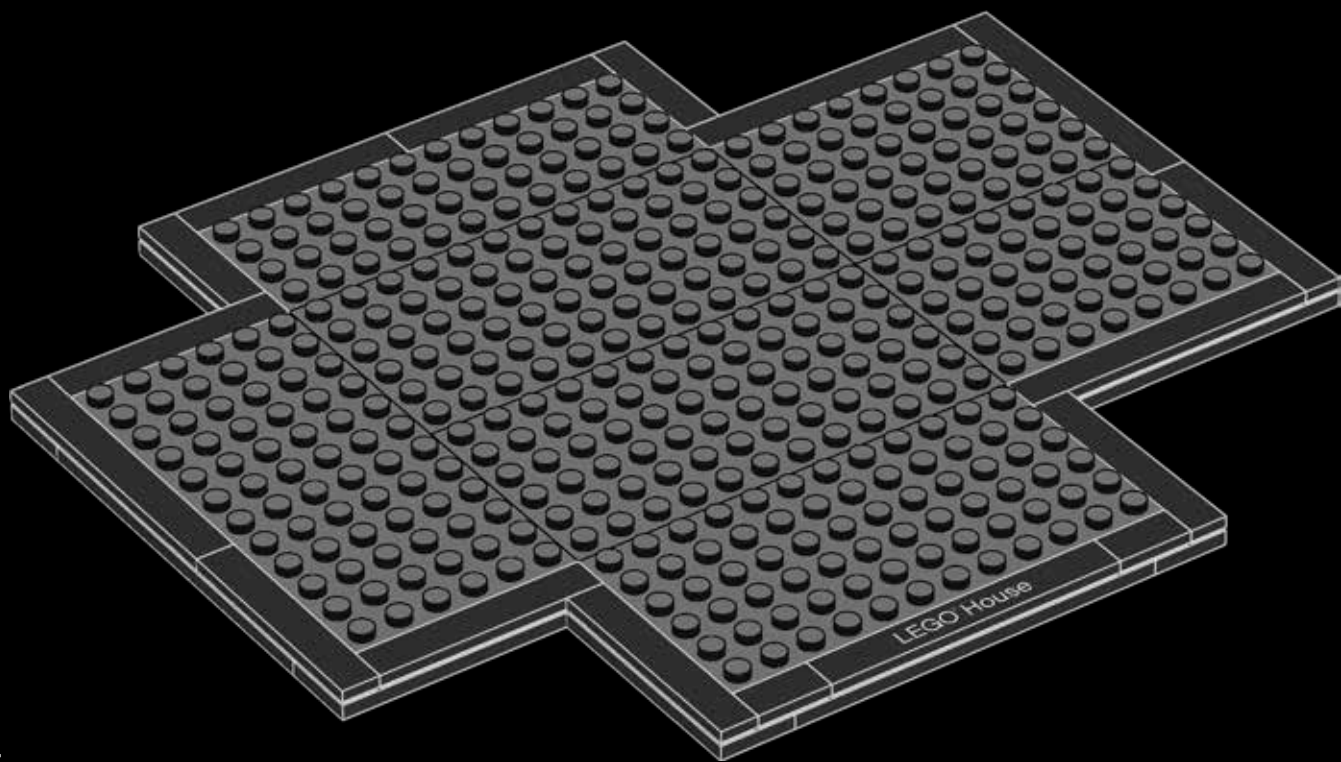



16

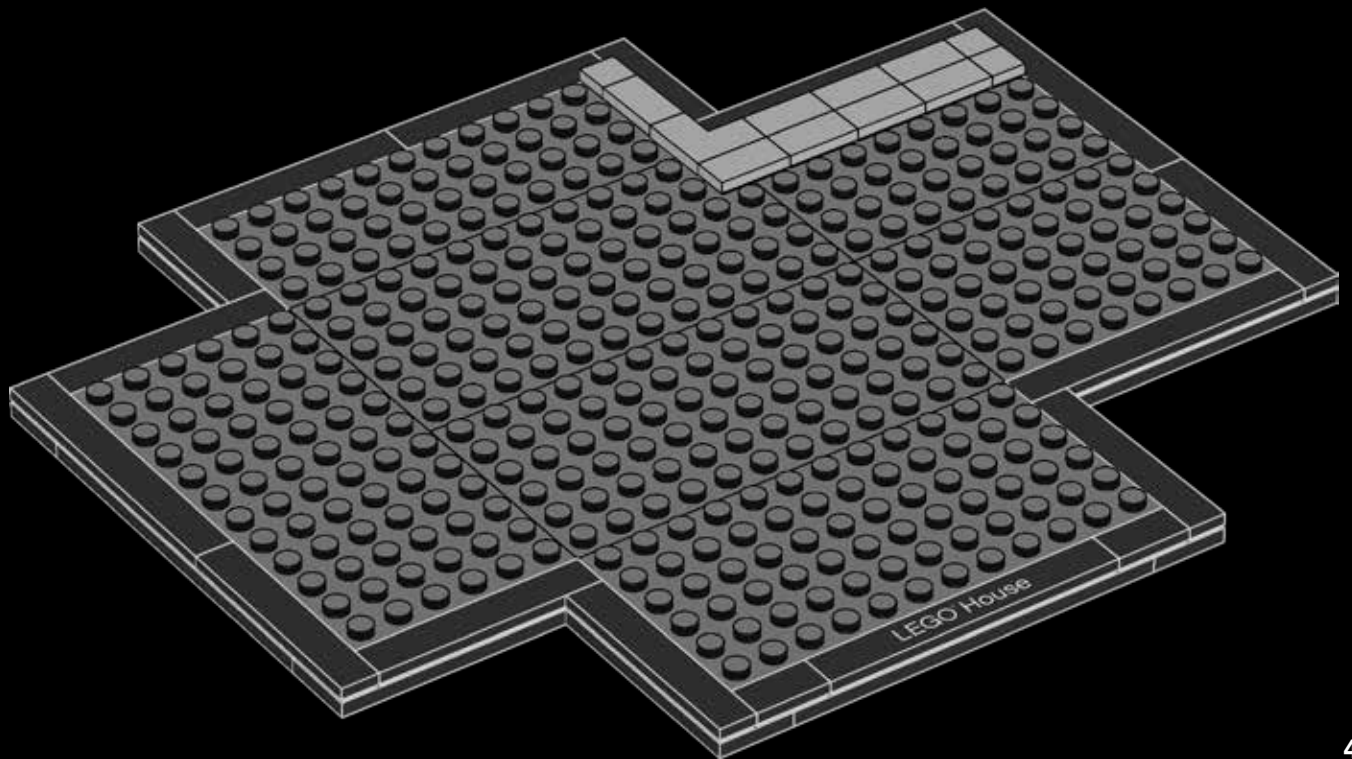

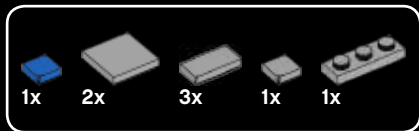

17

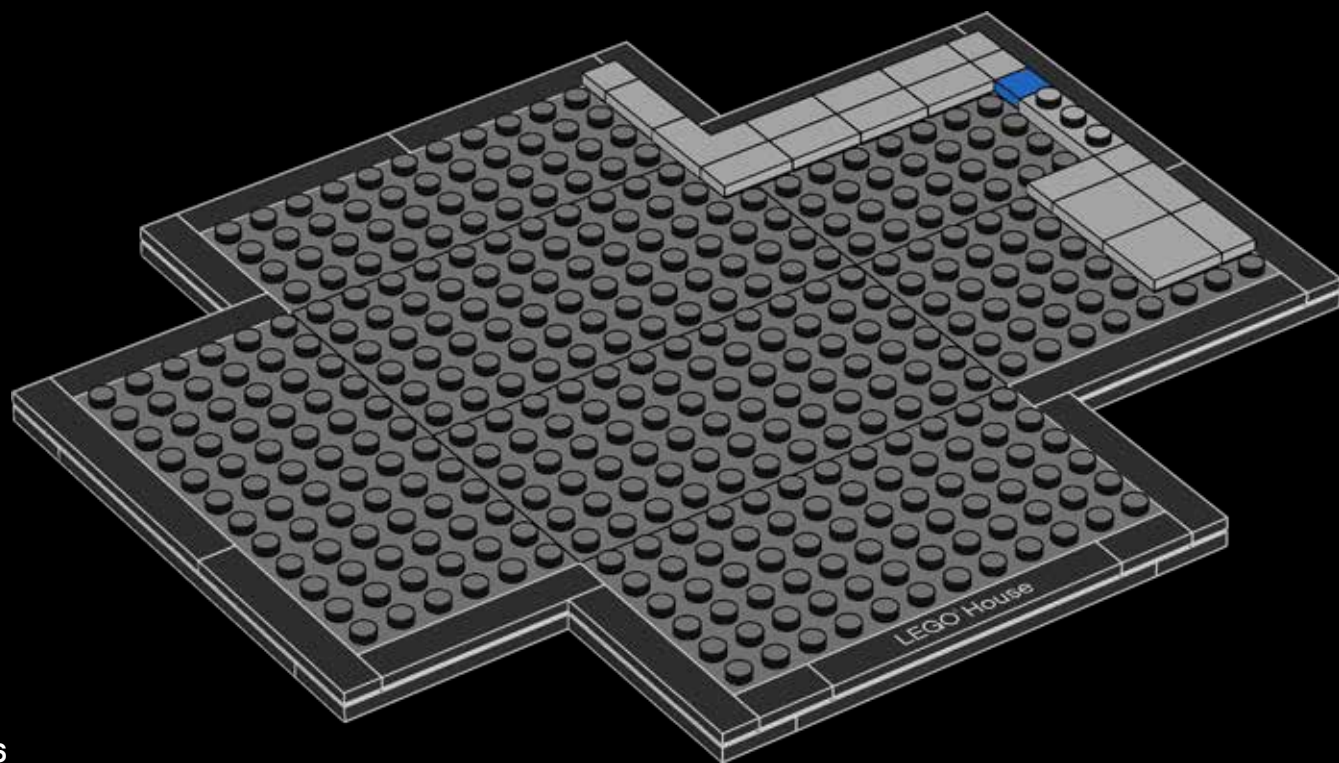



18



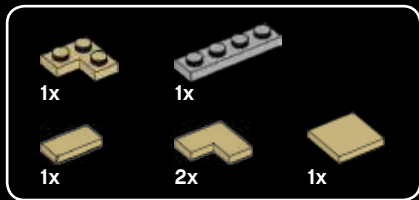

19

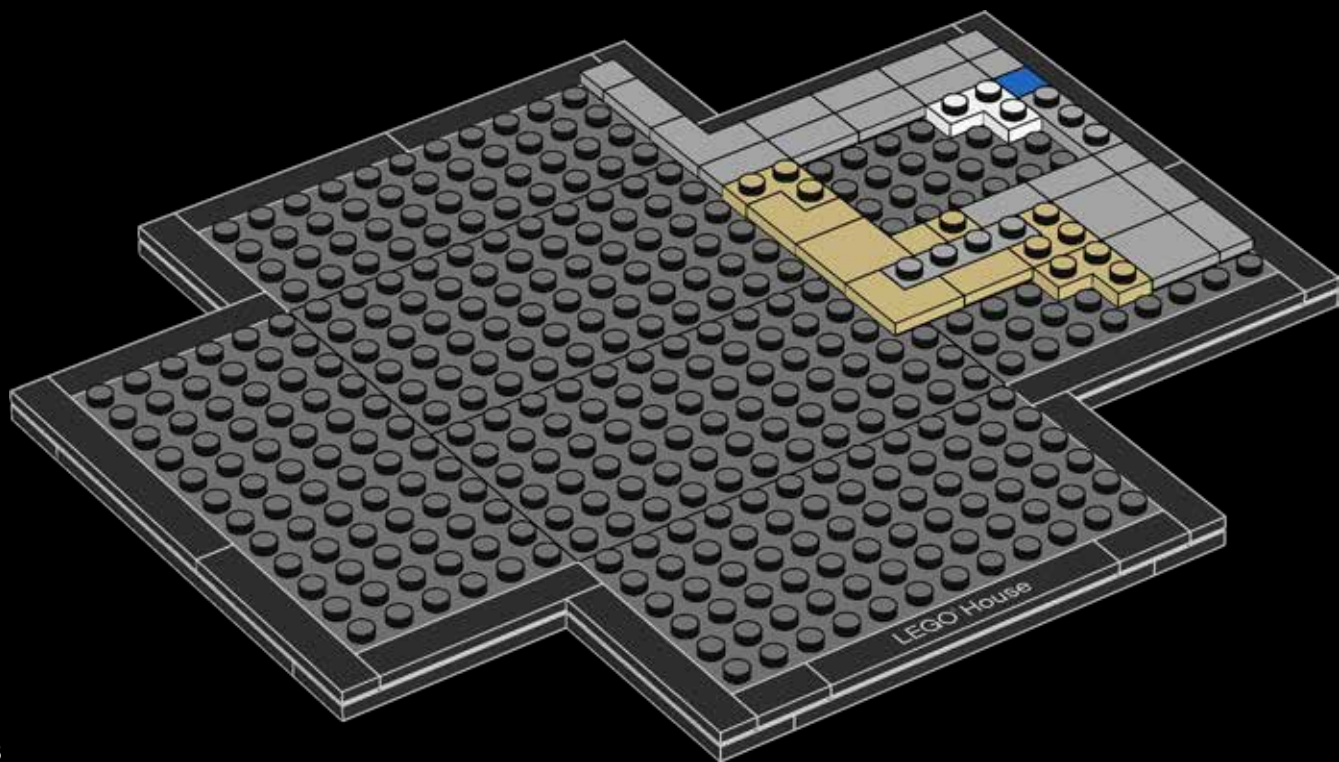



20

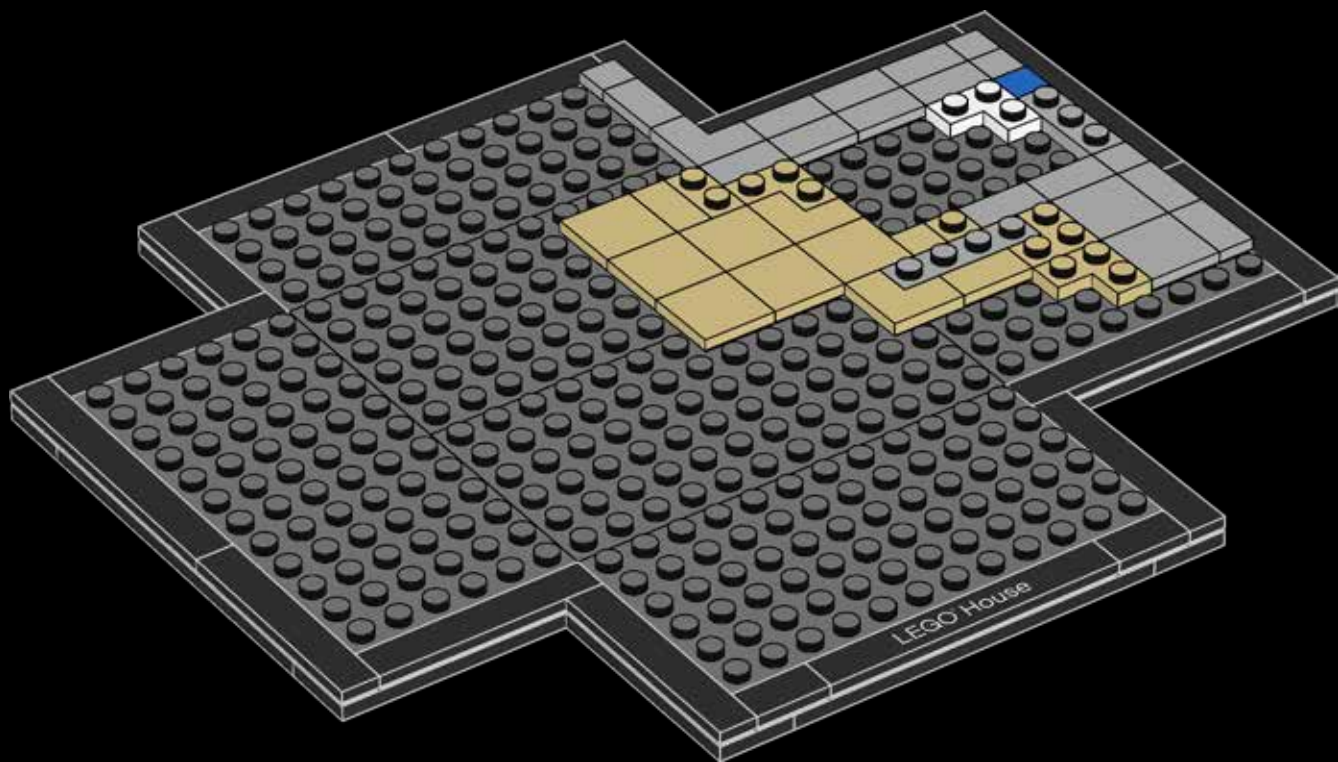

2x 3x 1x

21

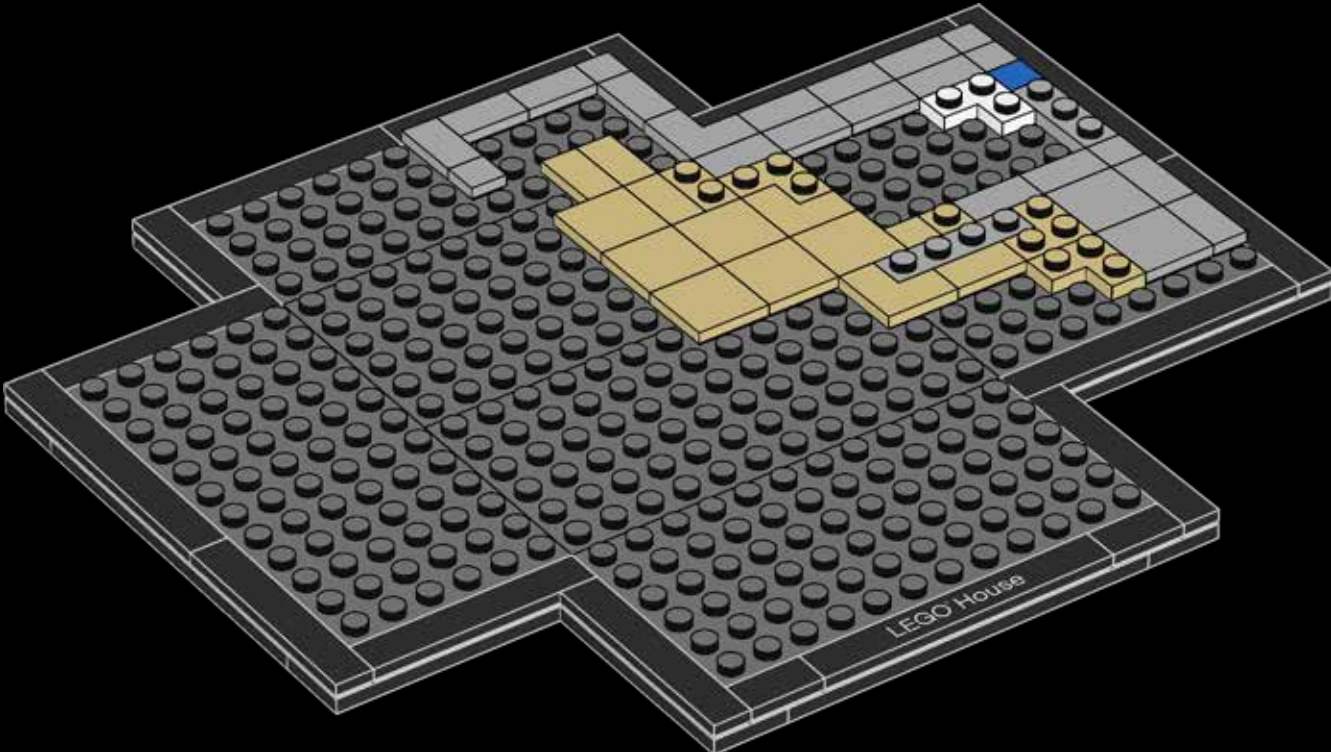

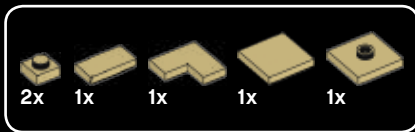

22

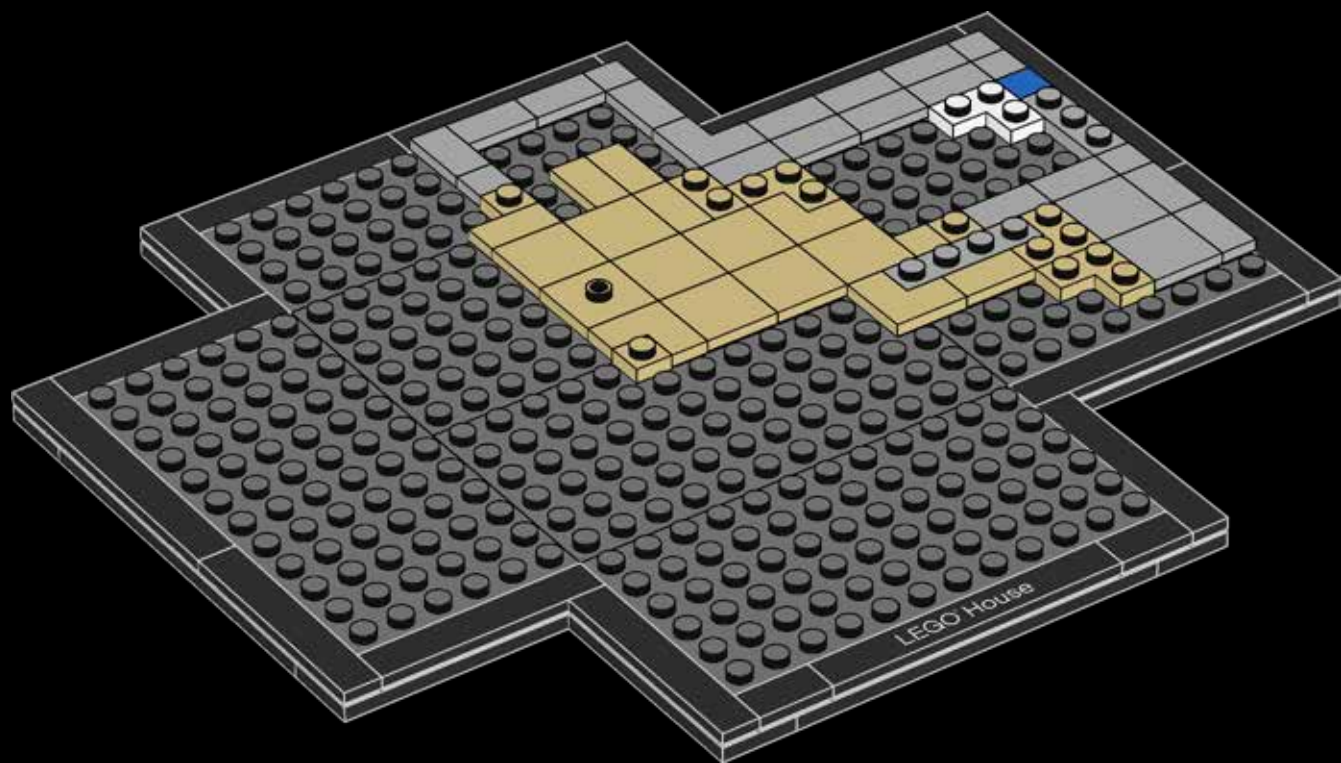



23

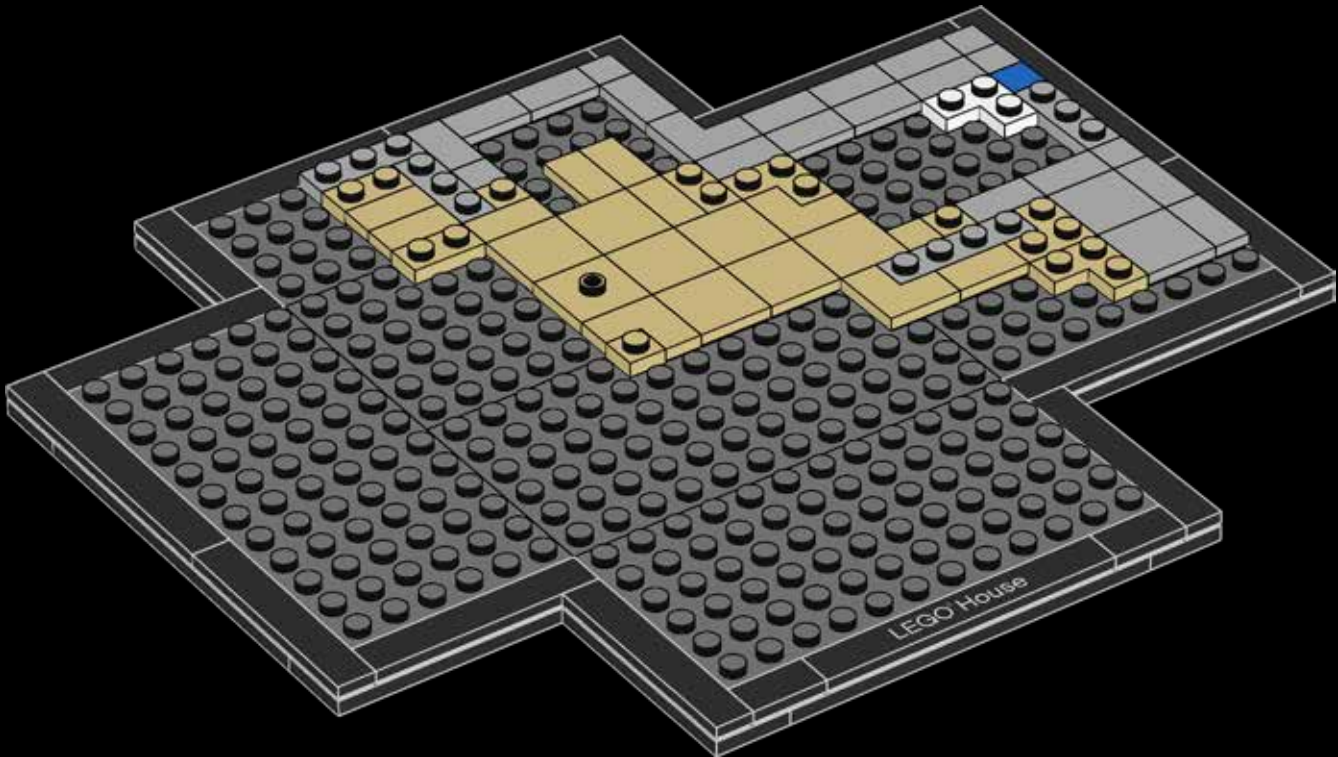

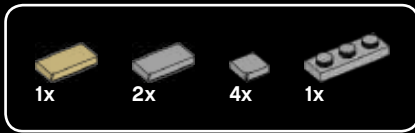

24

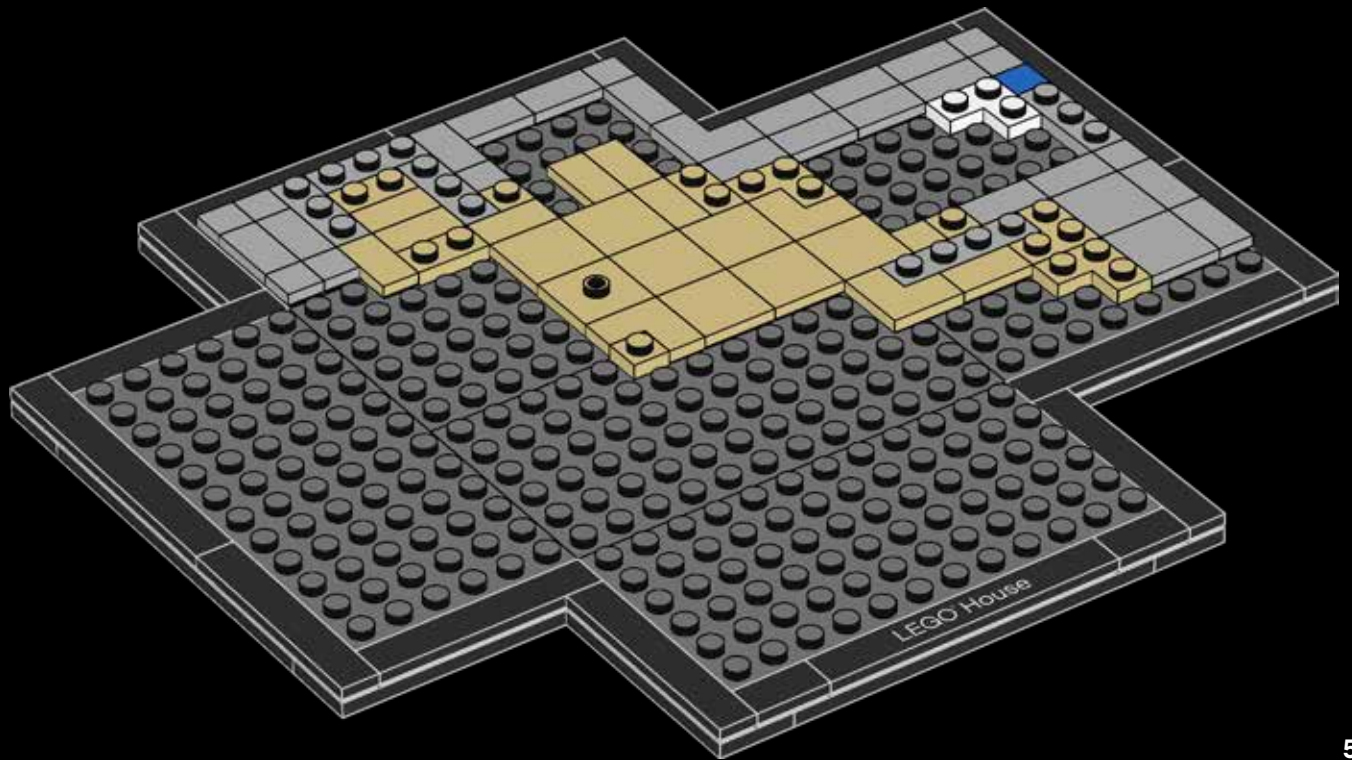



25

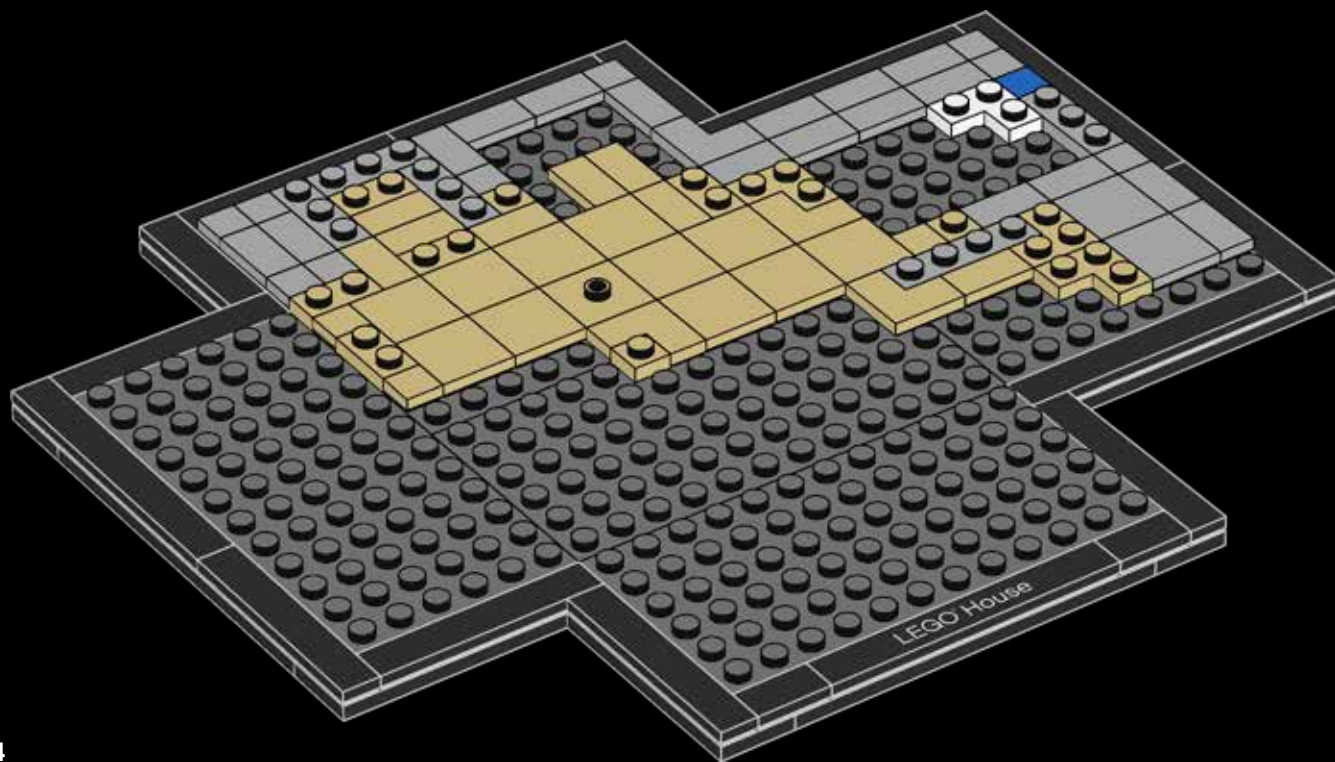



26

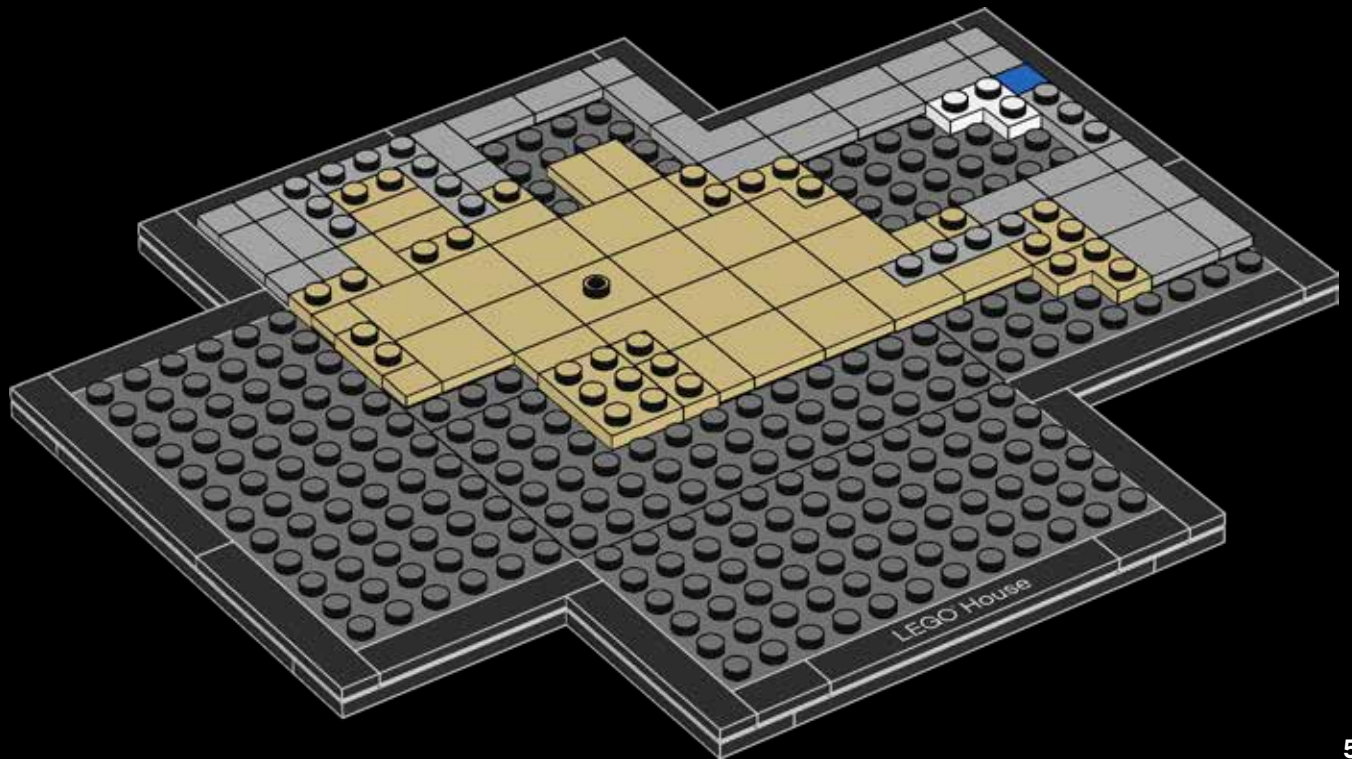



27

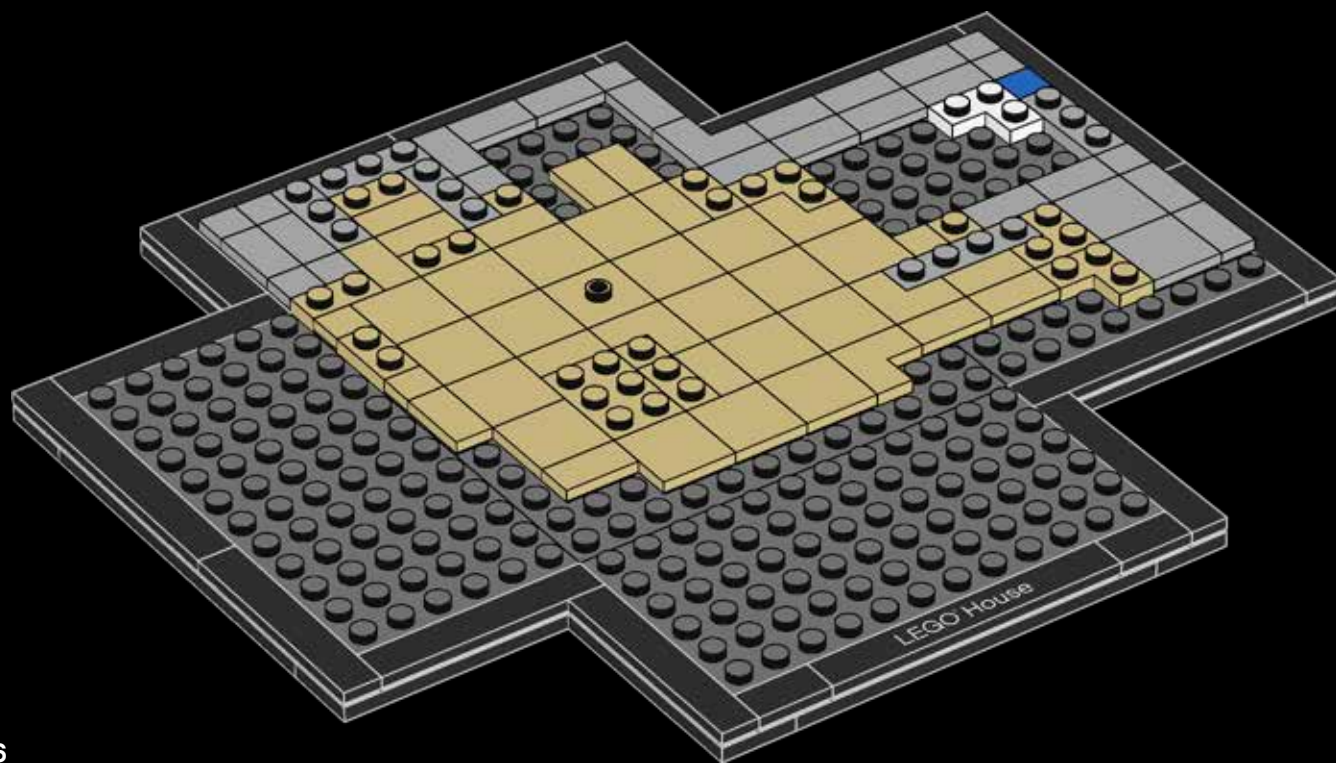



28

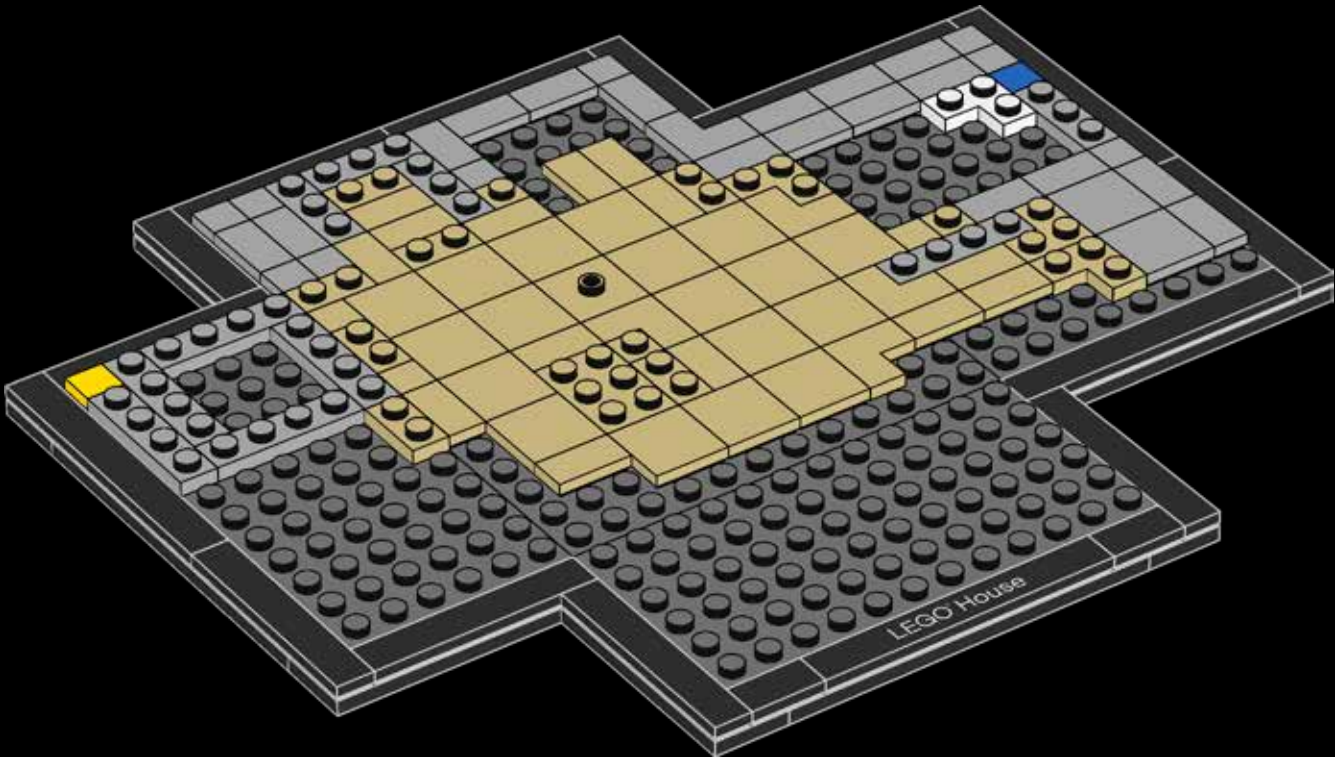

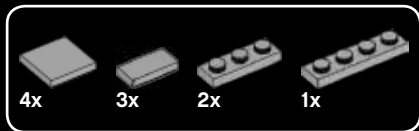

29

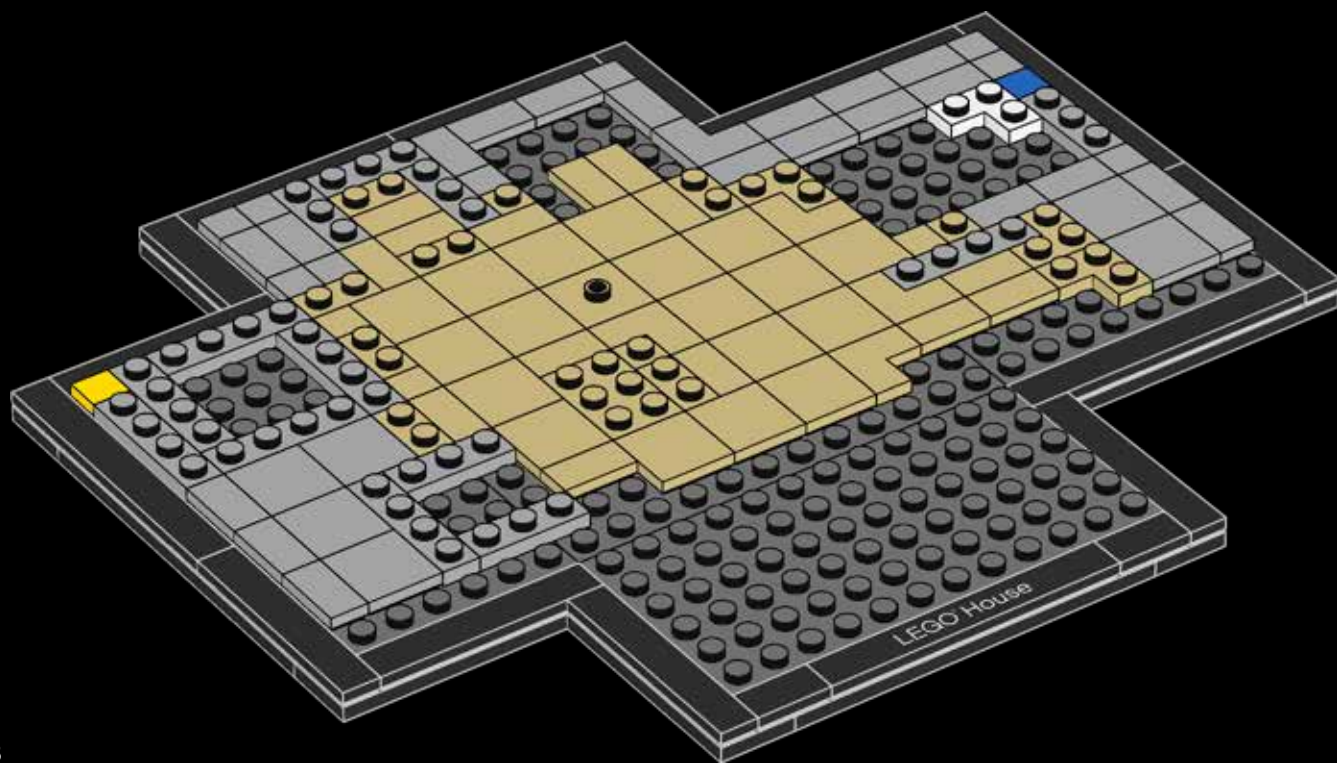



30

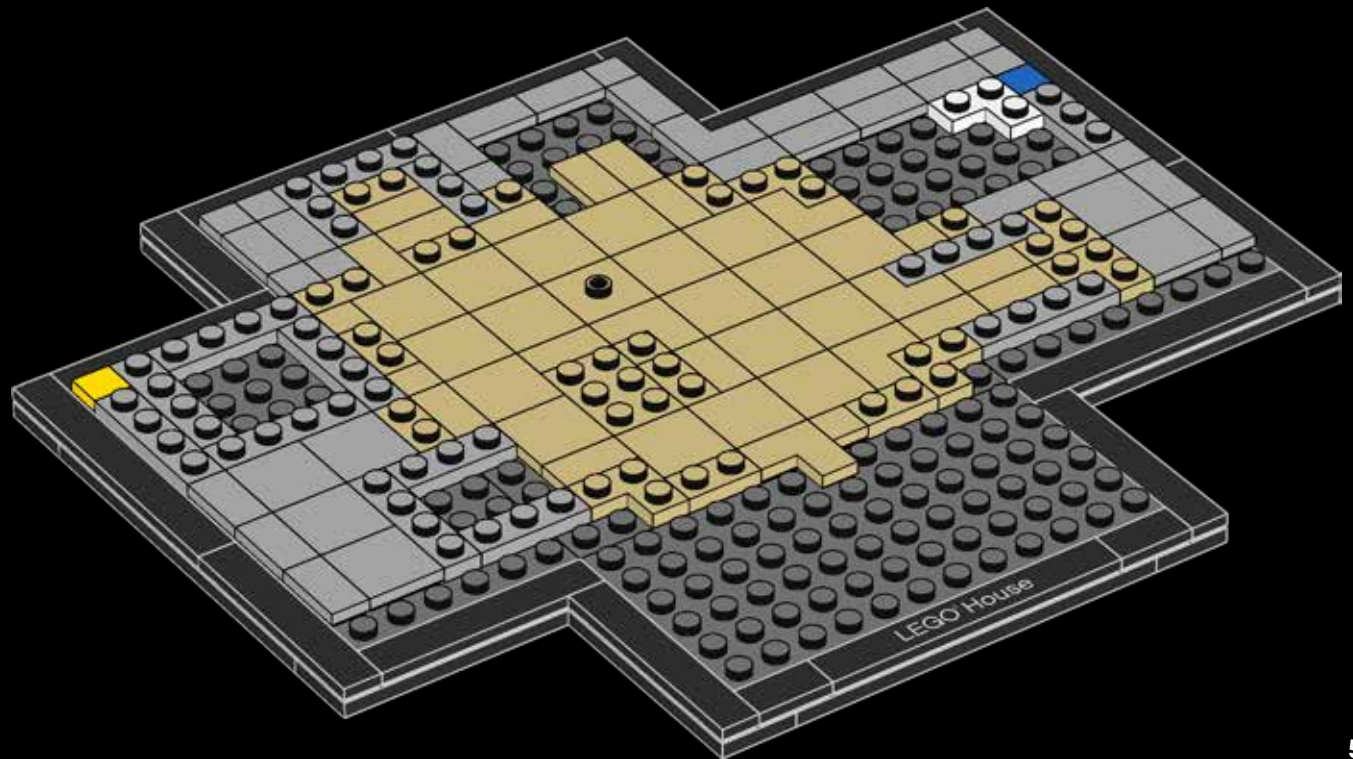



31

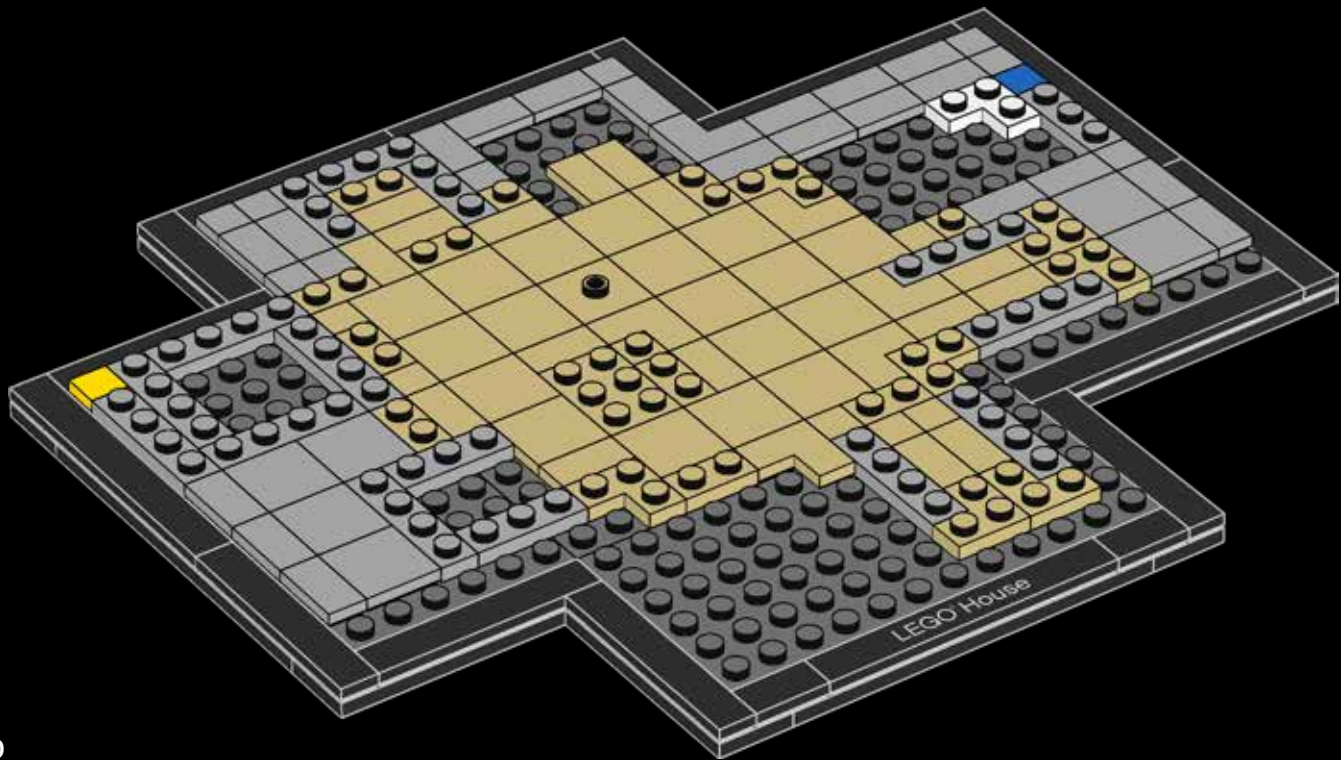



32

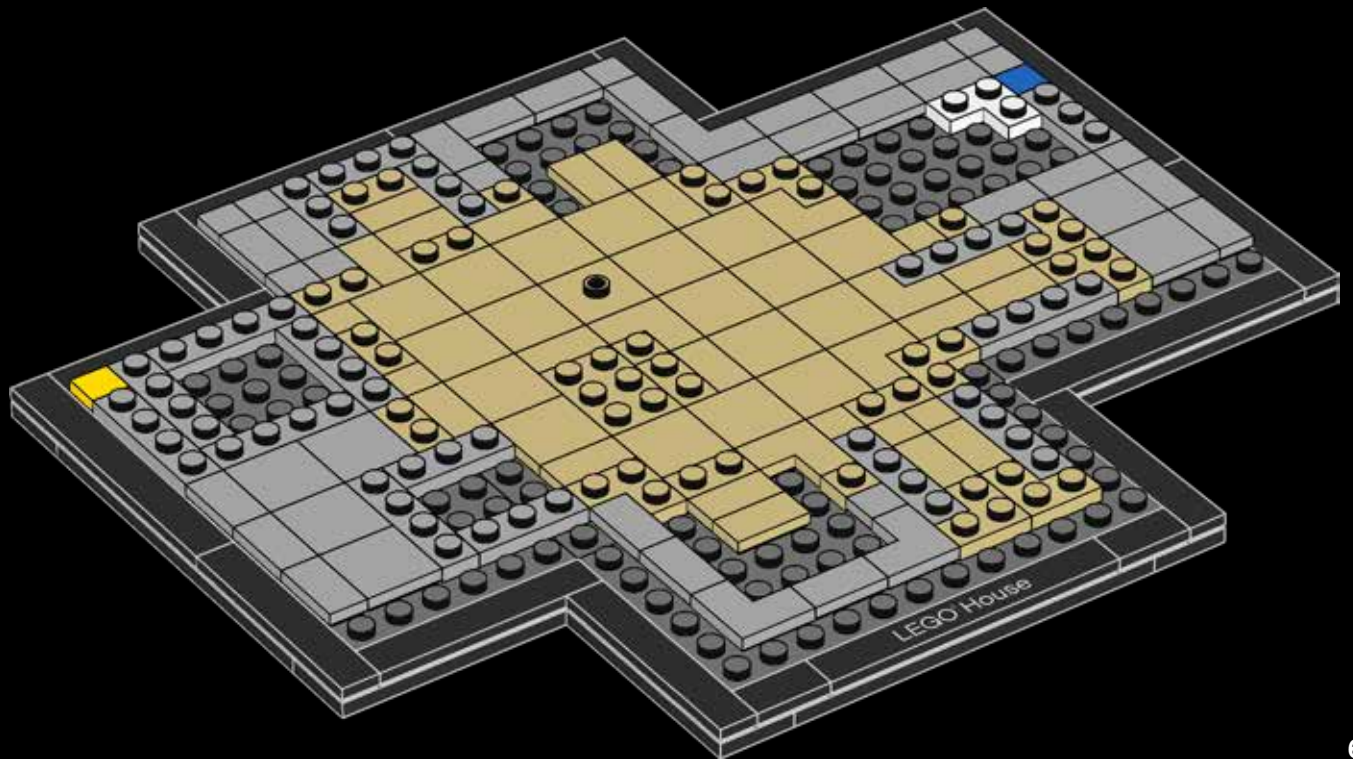

14x 4x 2x

33

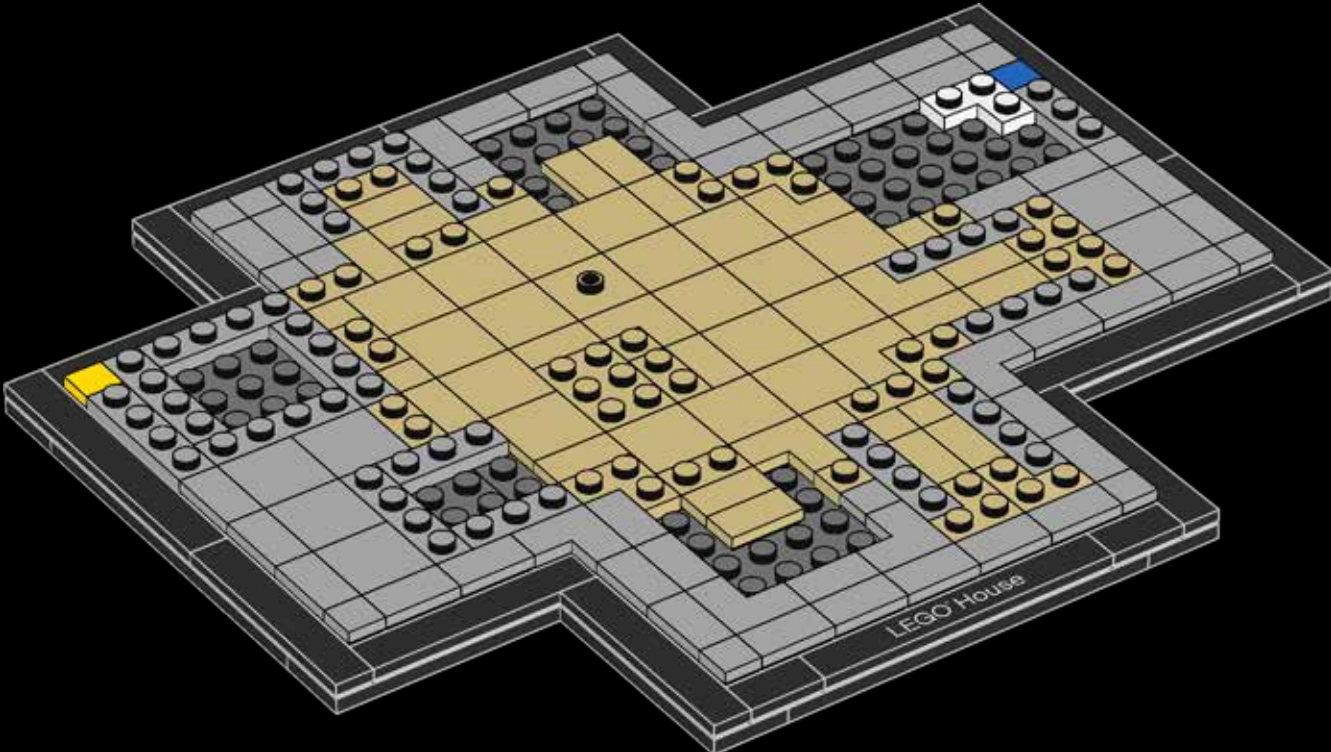

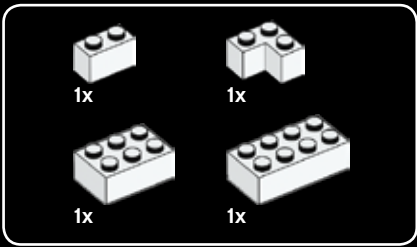

34

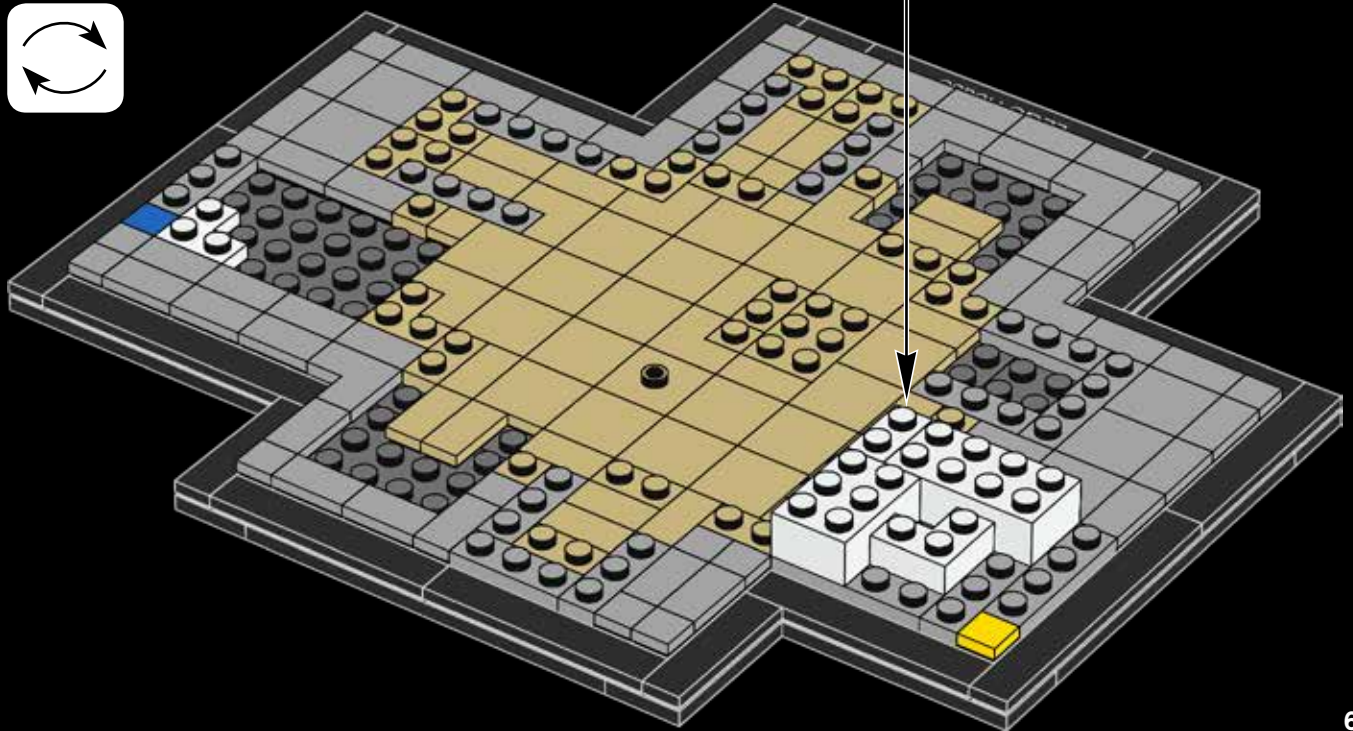



35

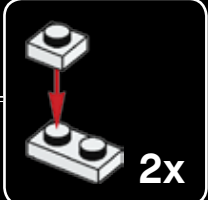
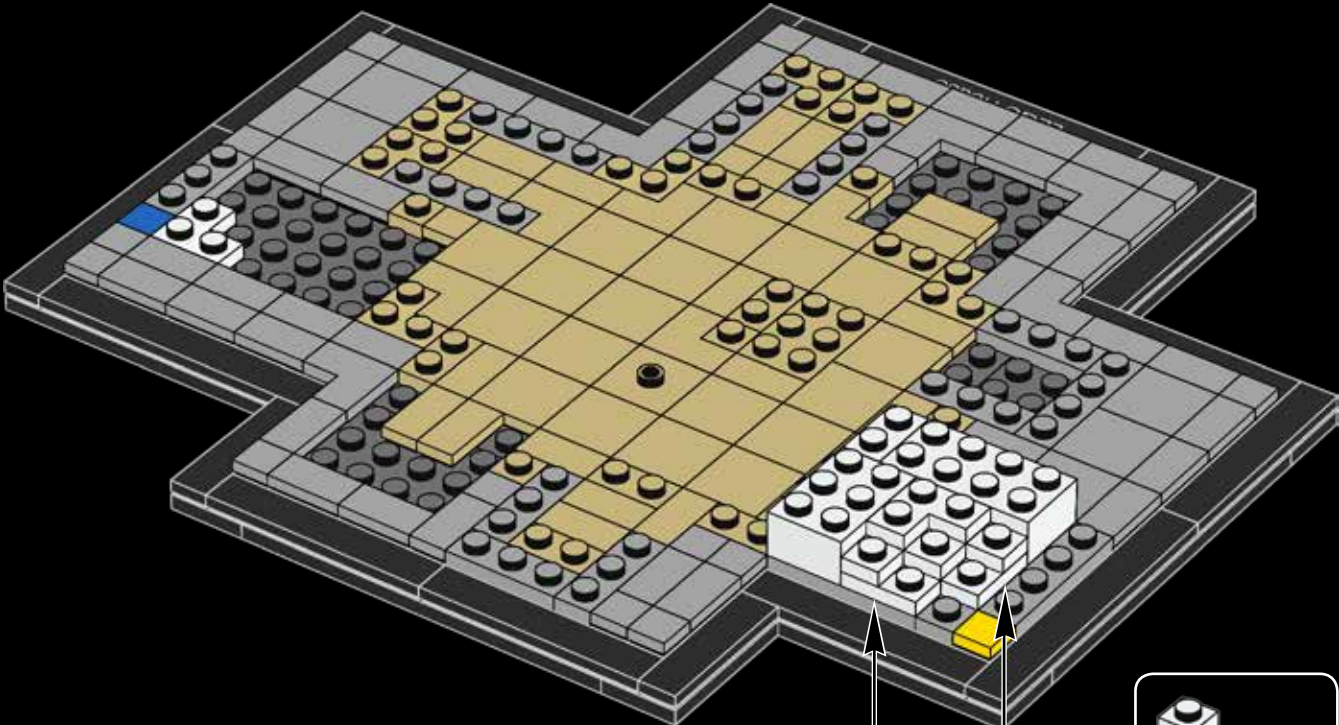



36

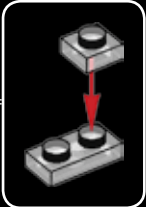
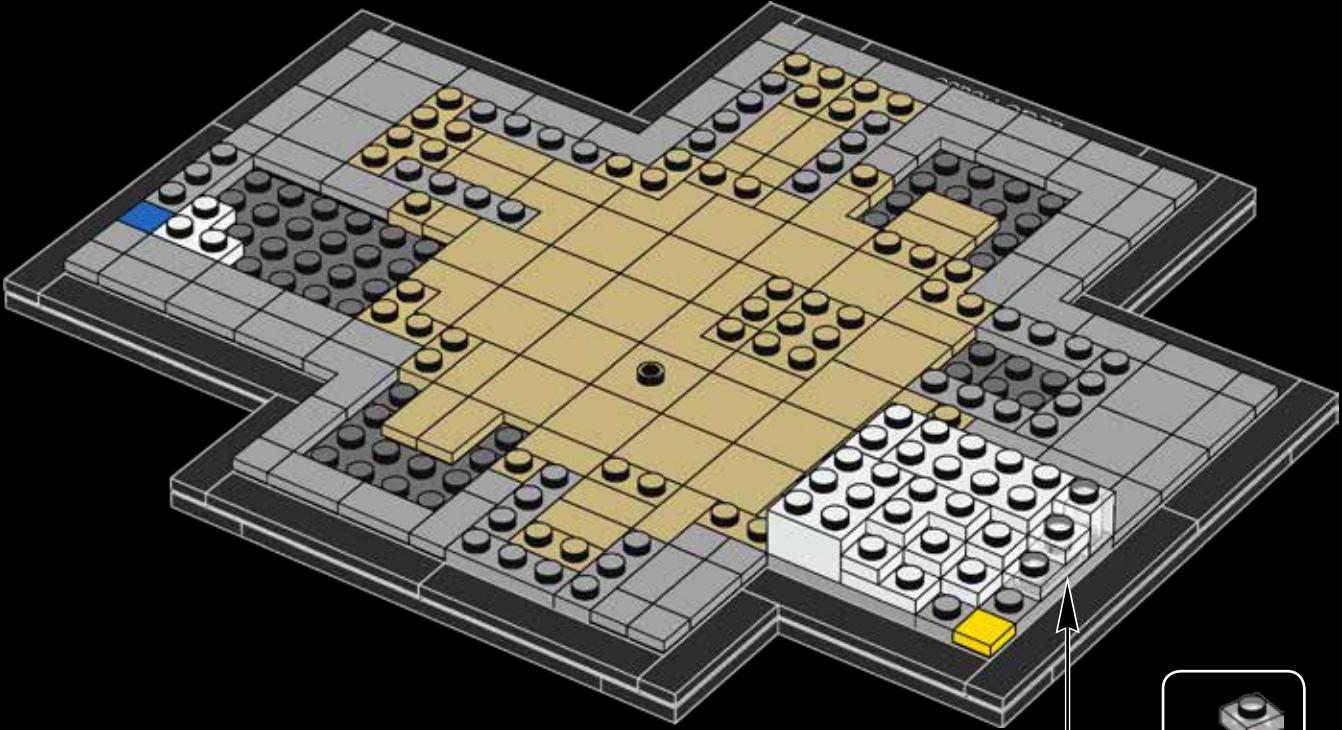



37

The building is covered with white facing bricks with a size of 7 x 23.5 in. (18 x 60 cm), giving the illusion that the building is made of LEGO® bricks.

Le bâtiment est recouvert de briques blanches d'une taille de 18 x 60 cm, donnant l'illusion que le bâtiment est fabriqué en briques LEGO®.

El edificio está cubierto de ladrillos blancos con un tamaño de 18 x 60 cm para crear la ilusión de que está construido con bricks LEGO®.

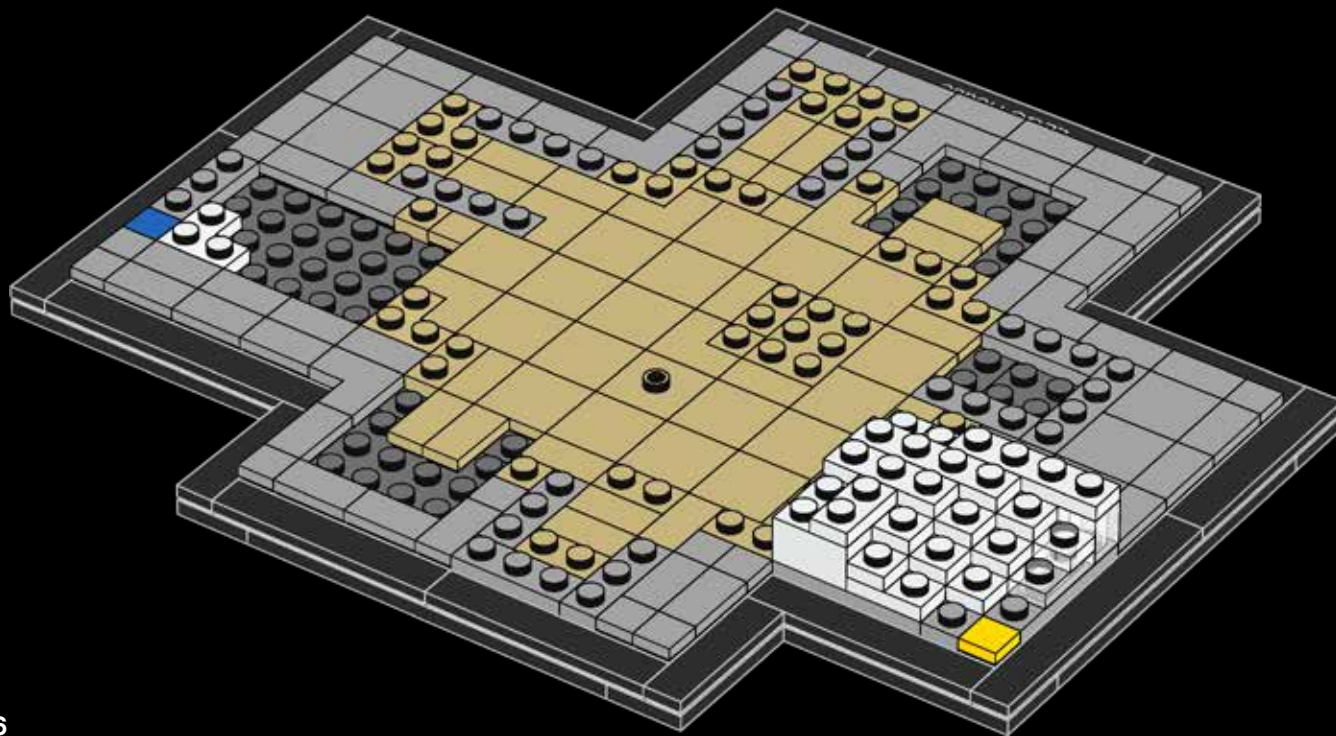



38

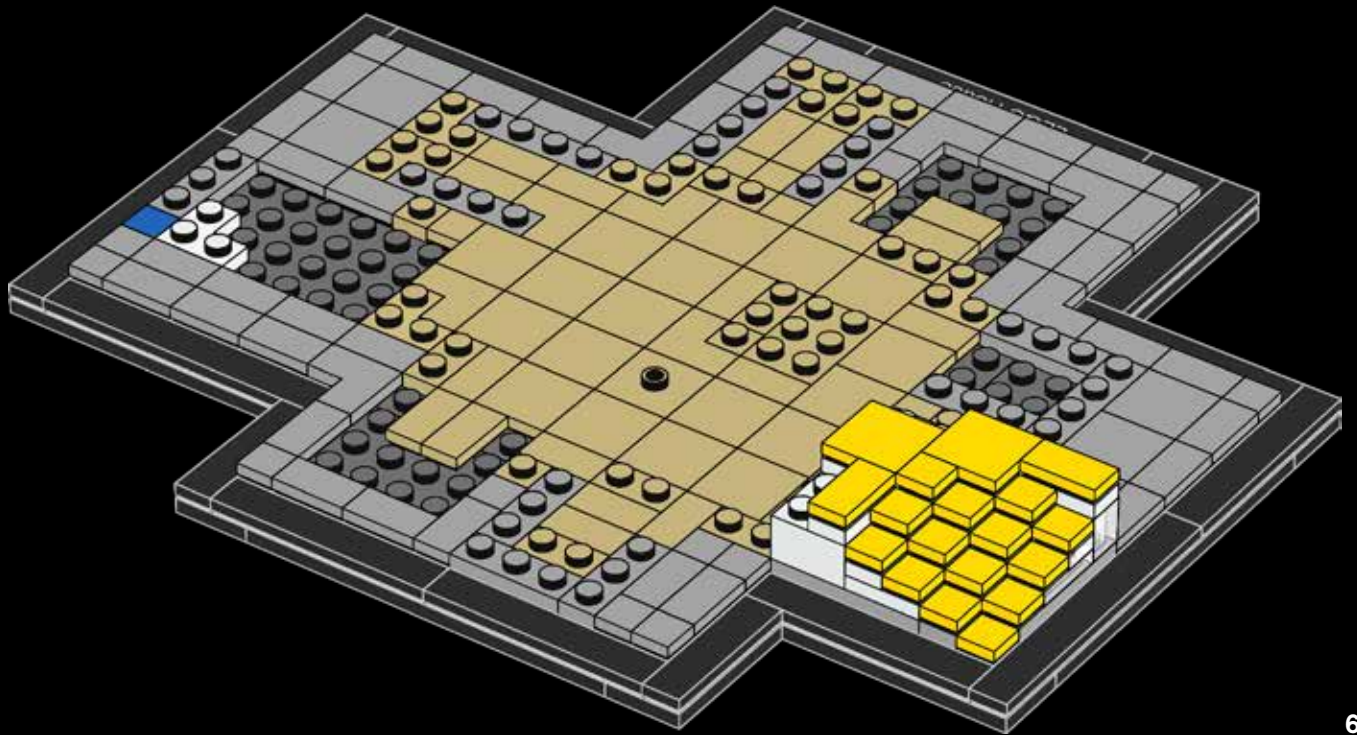



39

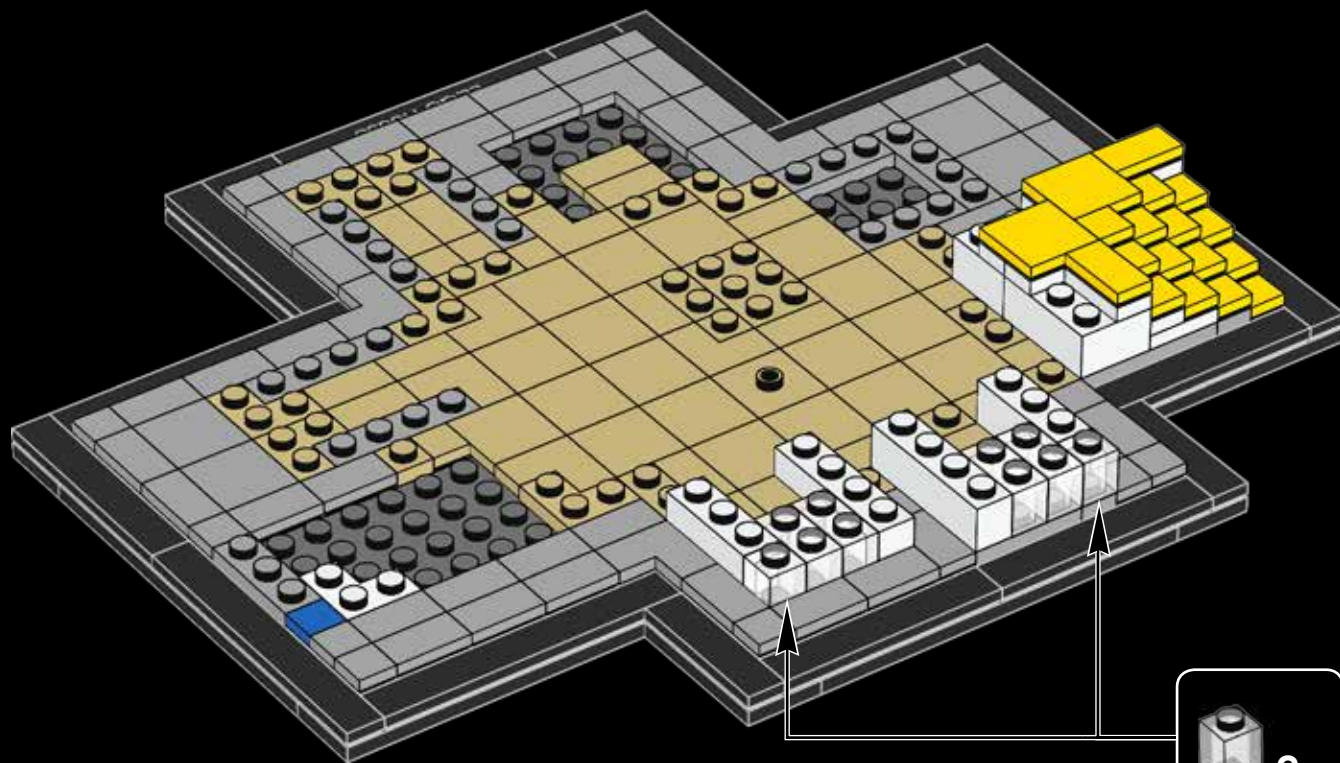



40

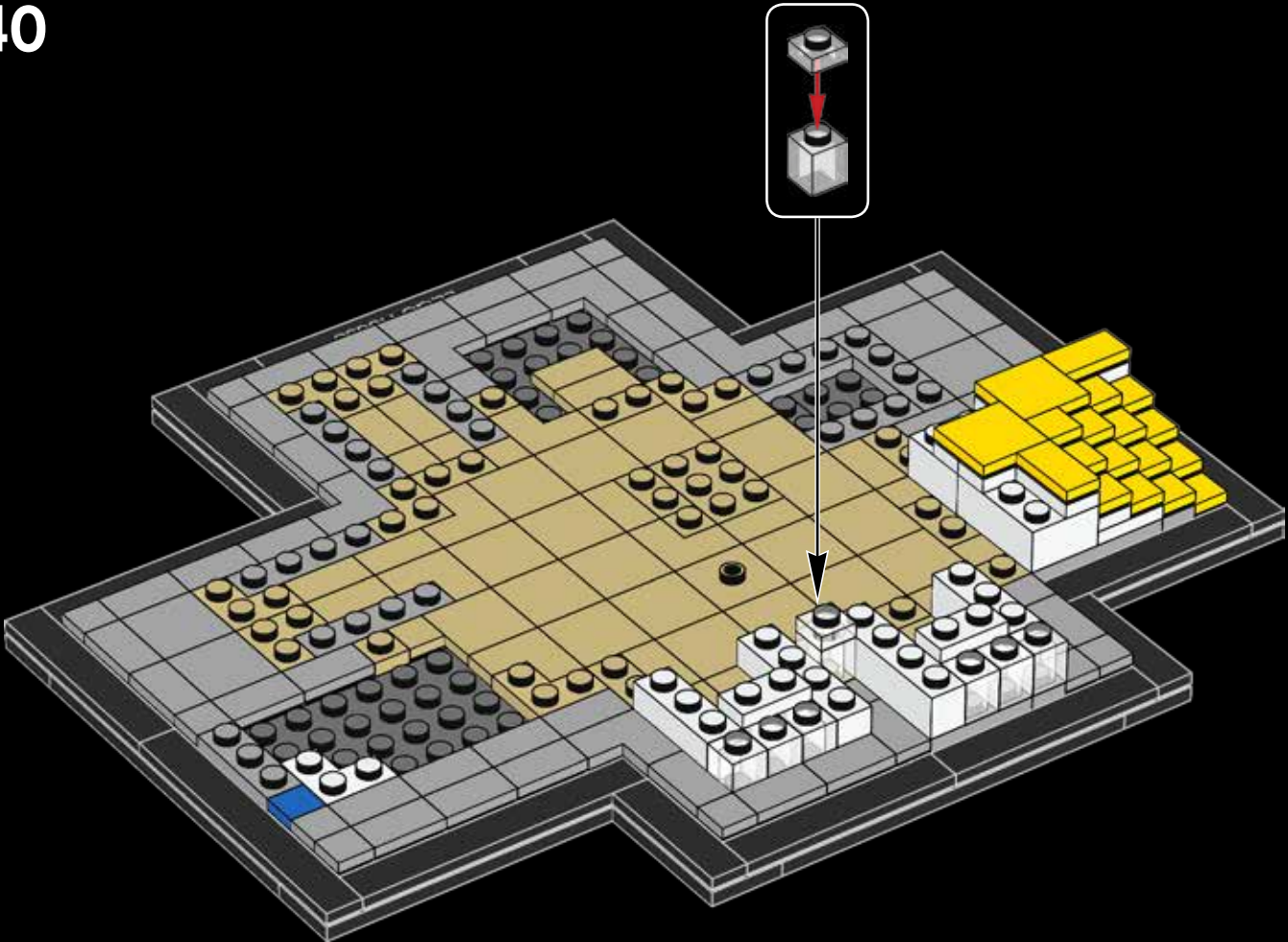



41

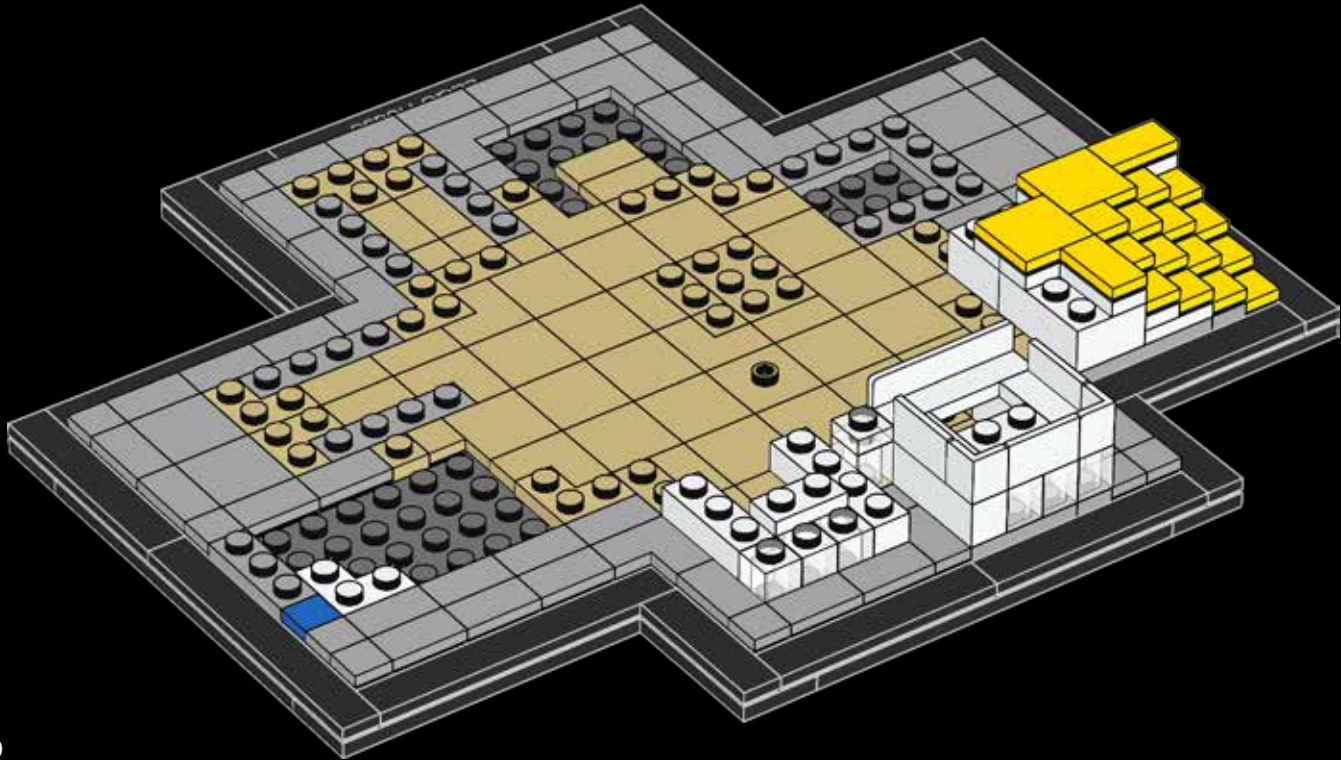



42

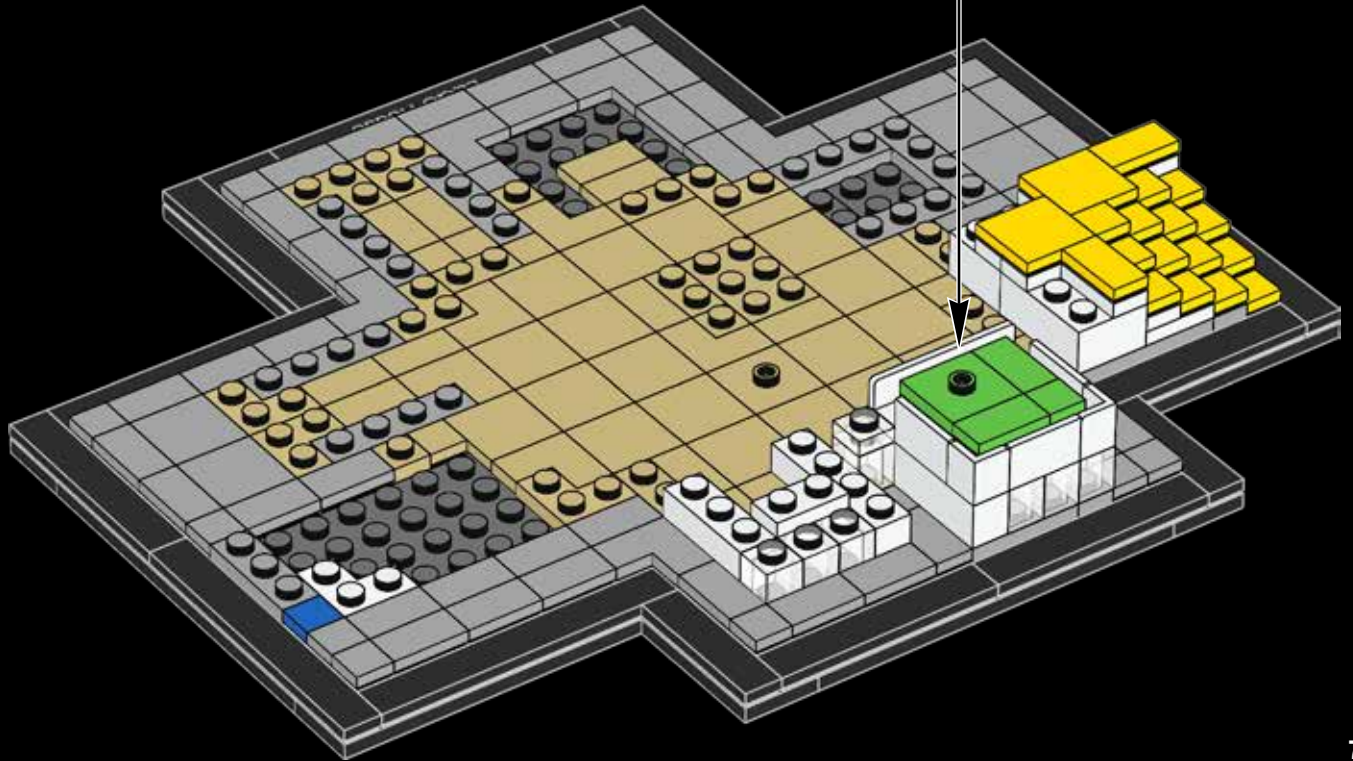
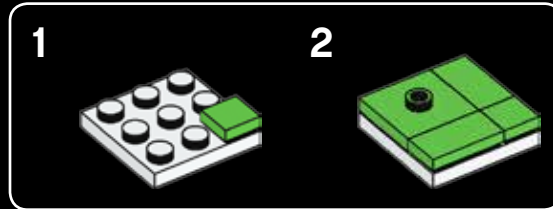

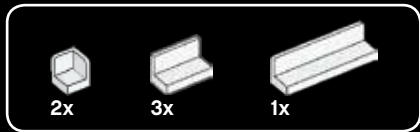

43

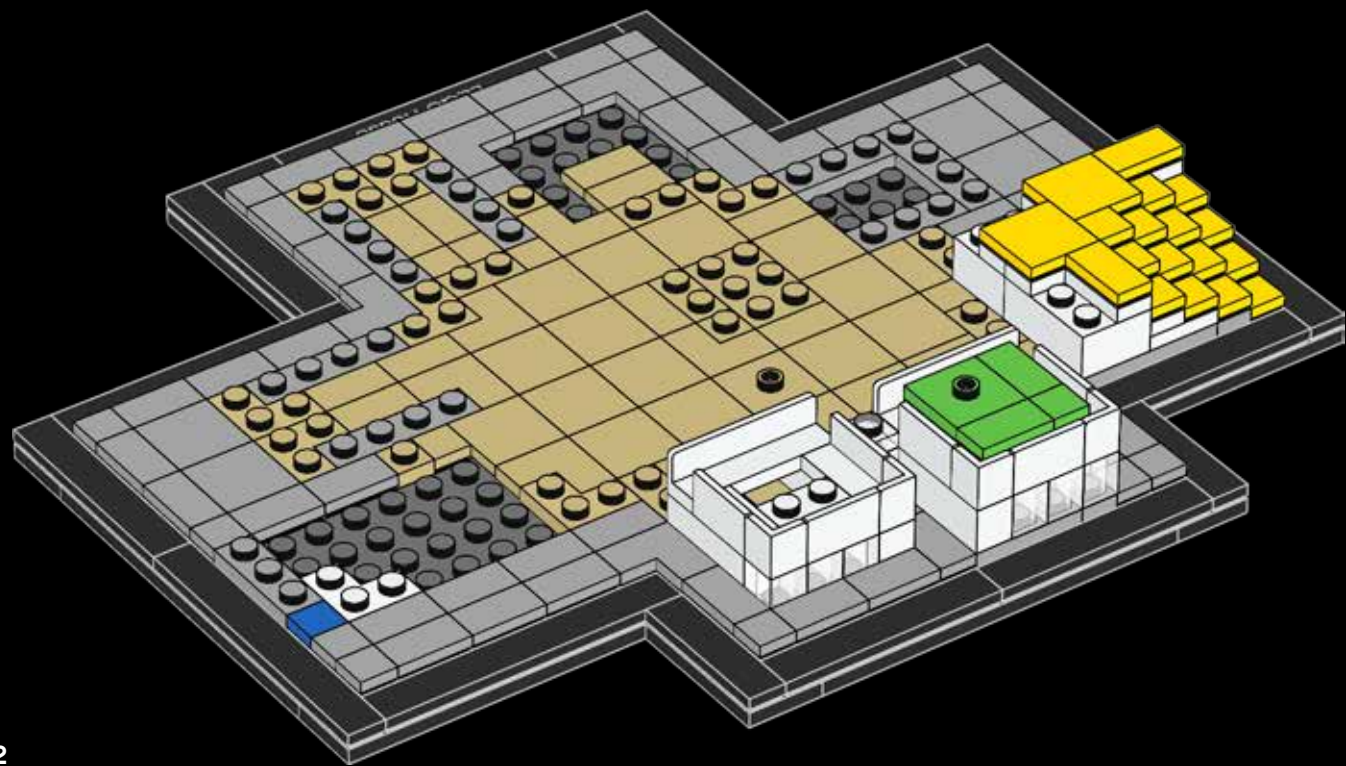

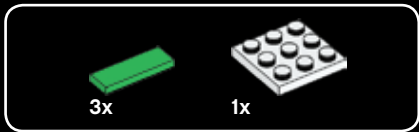

44

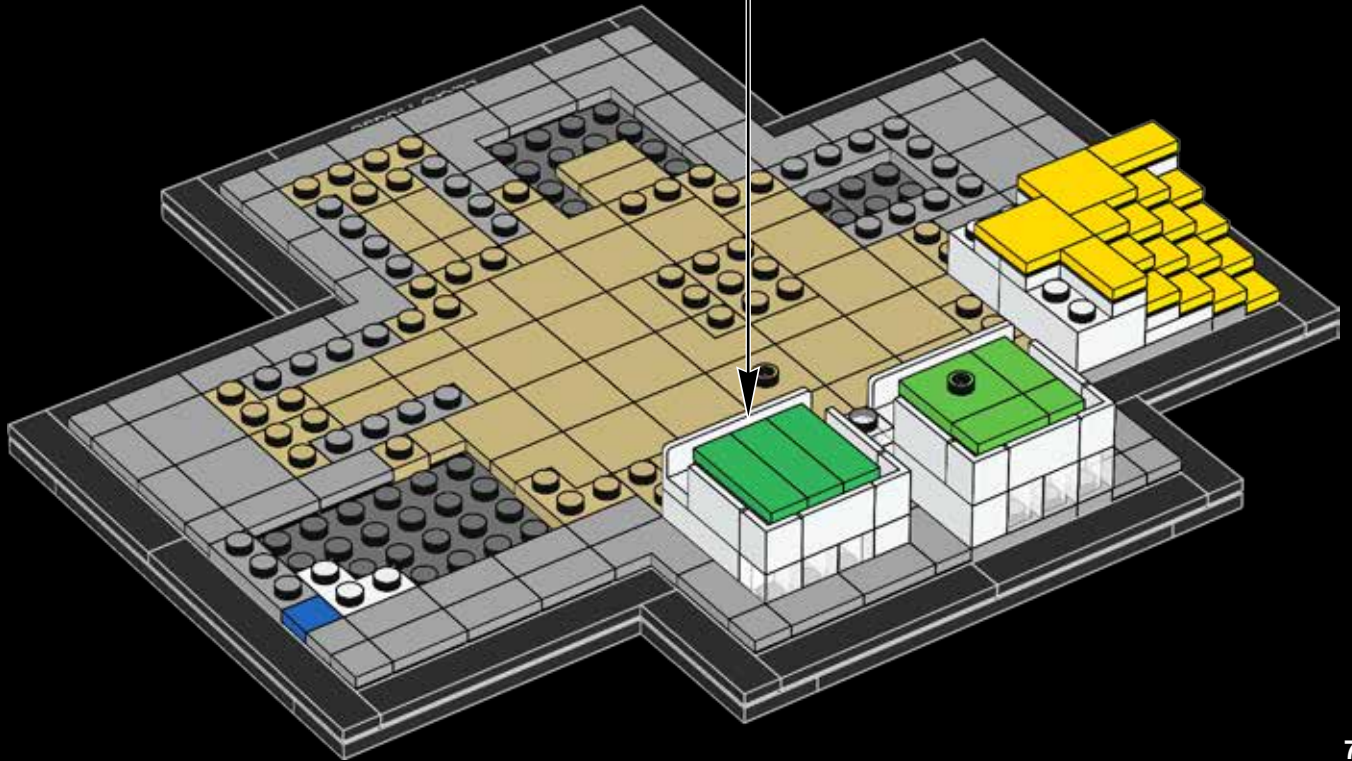
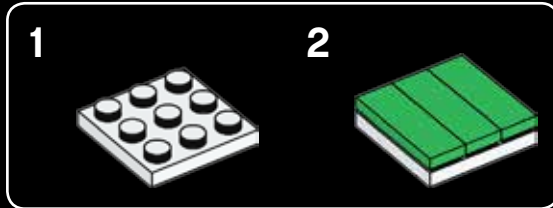



45

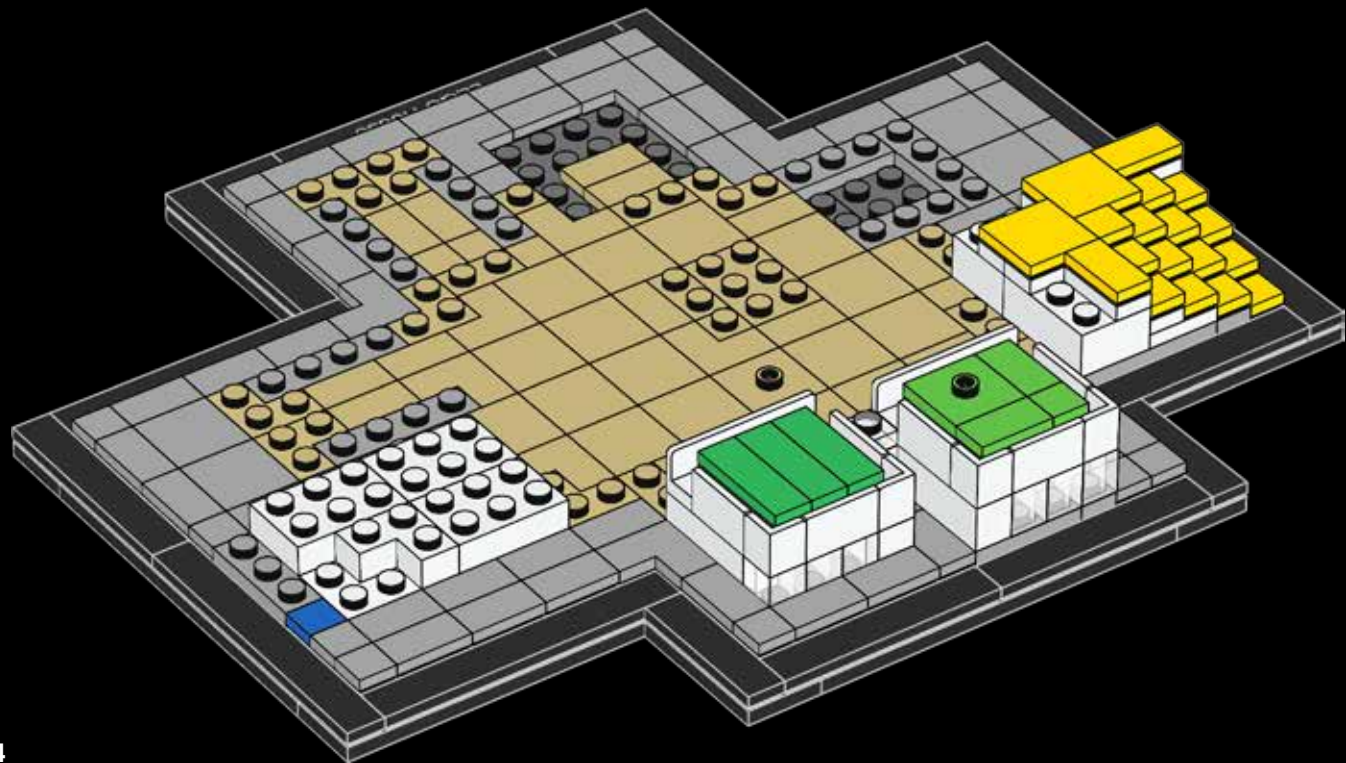

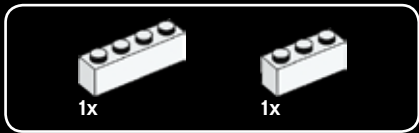

46

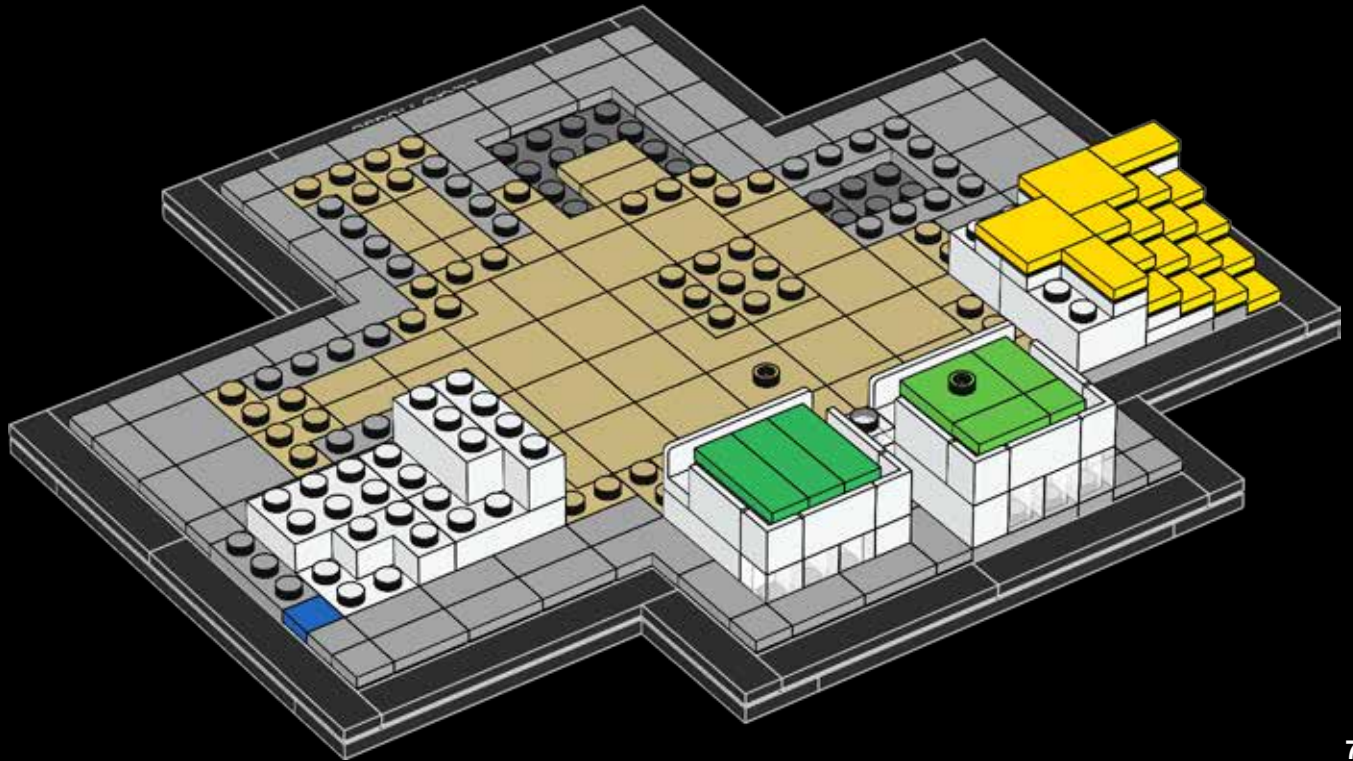

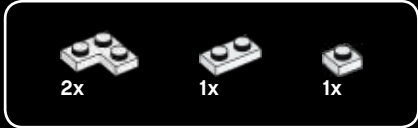

47

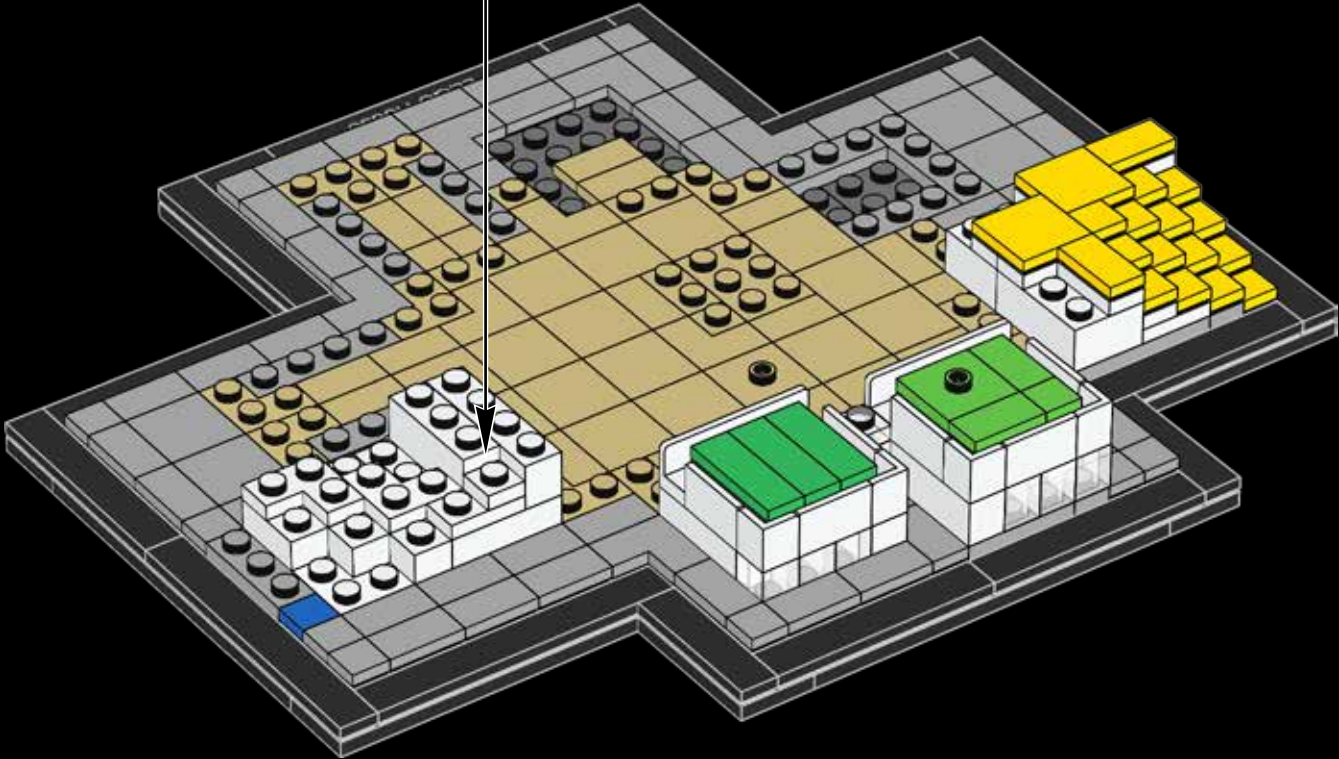
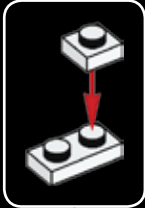

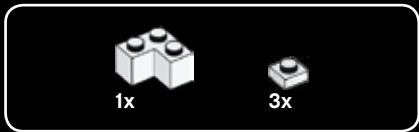

48

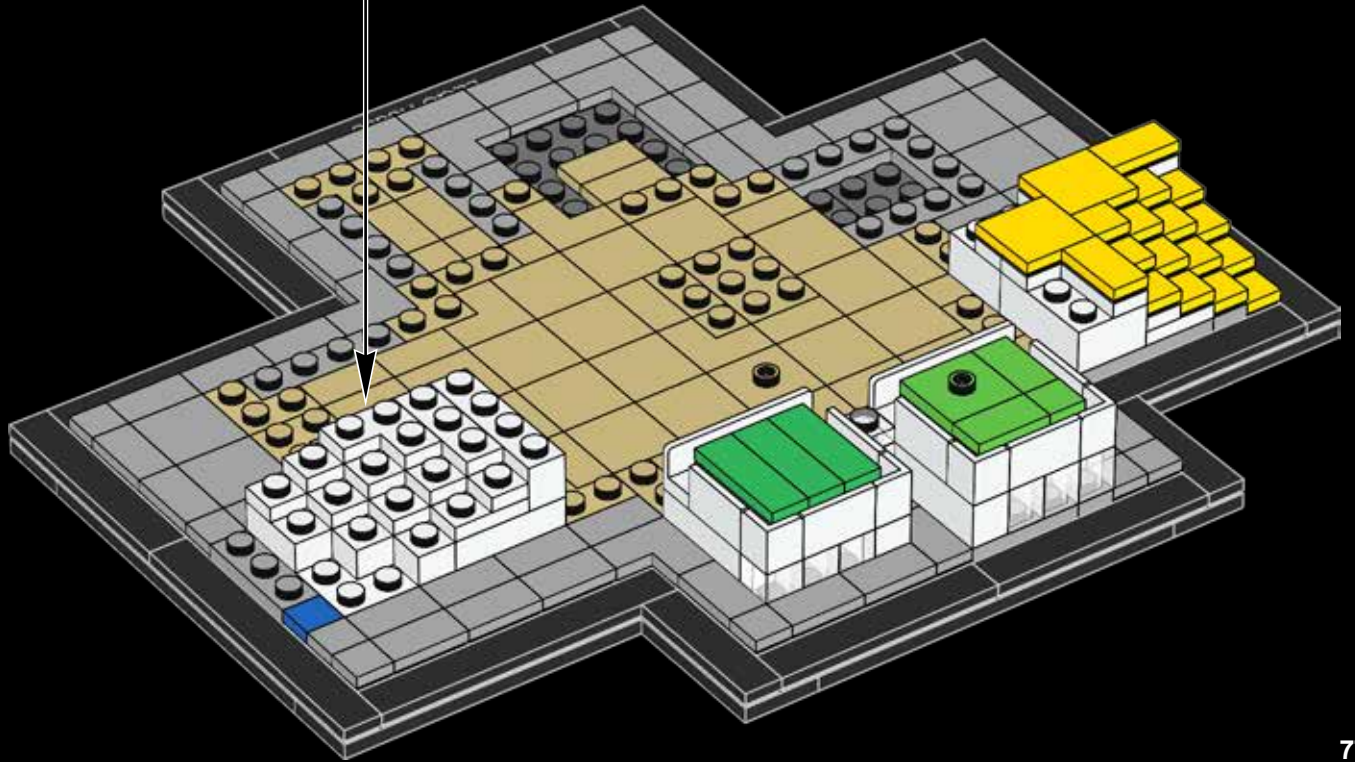

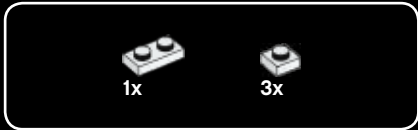

49

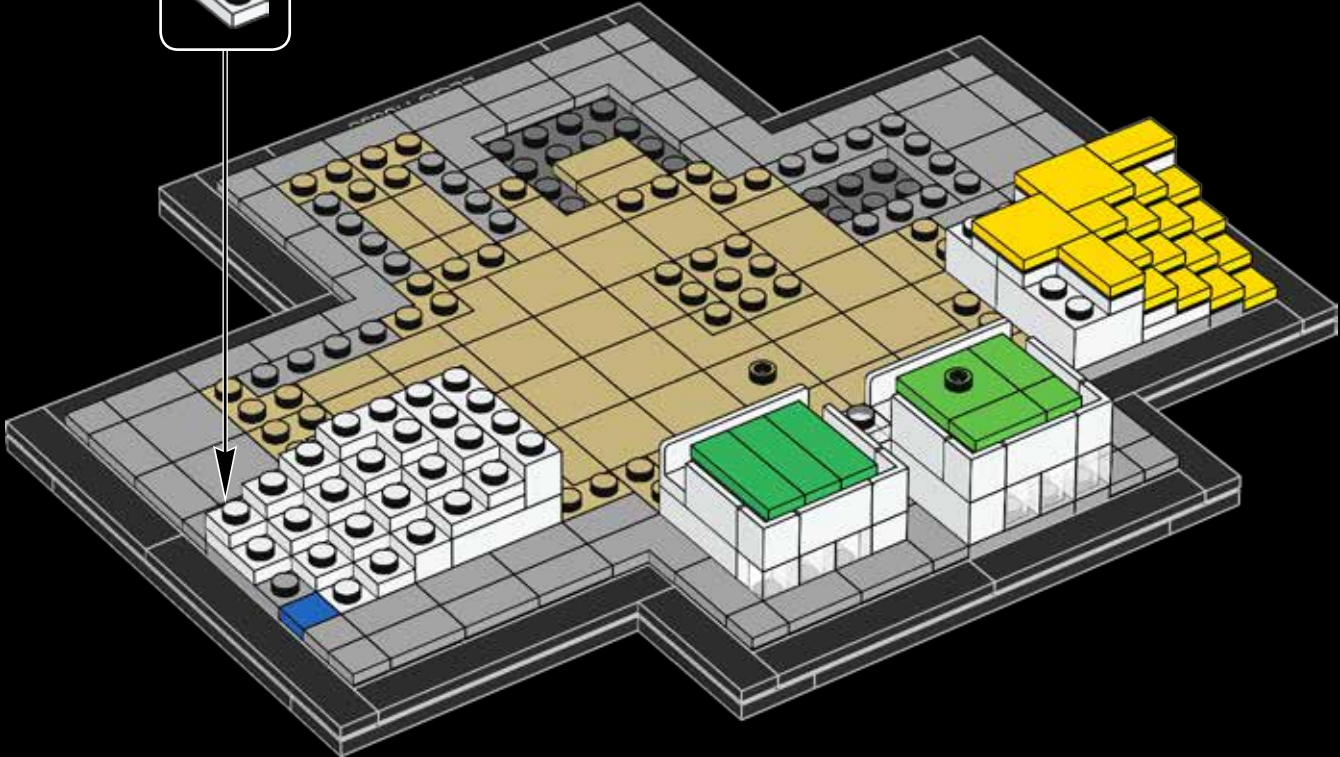
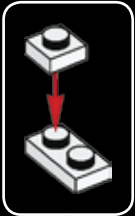

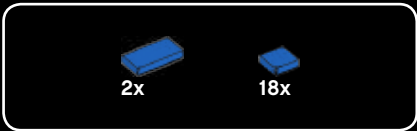

50

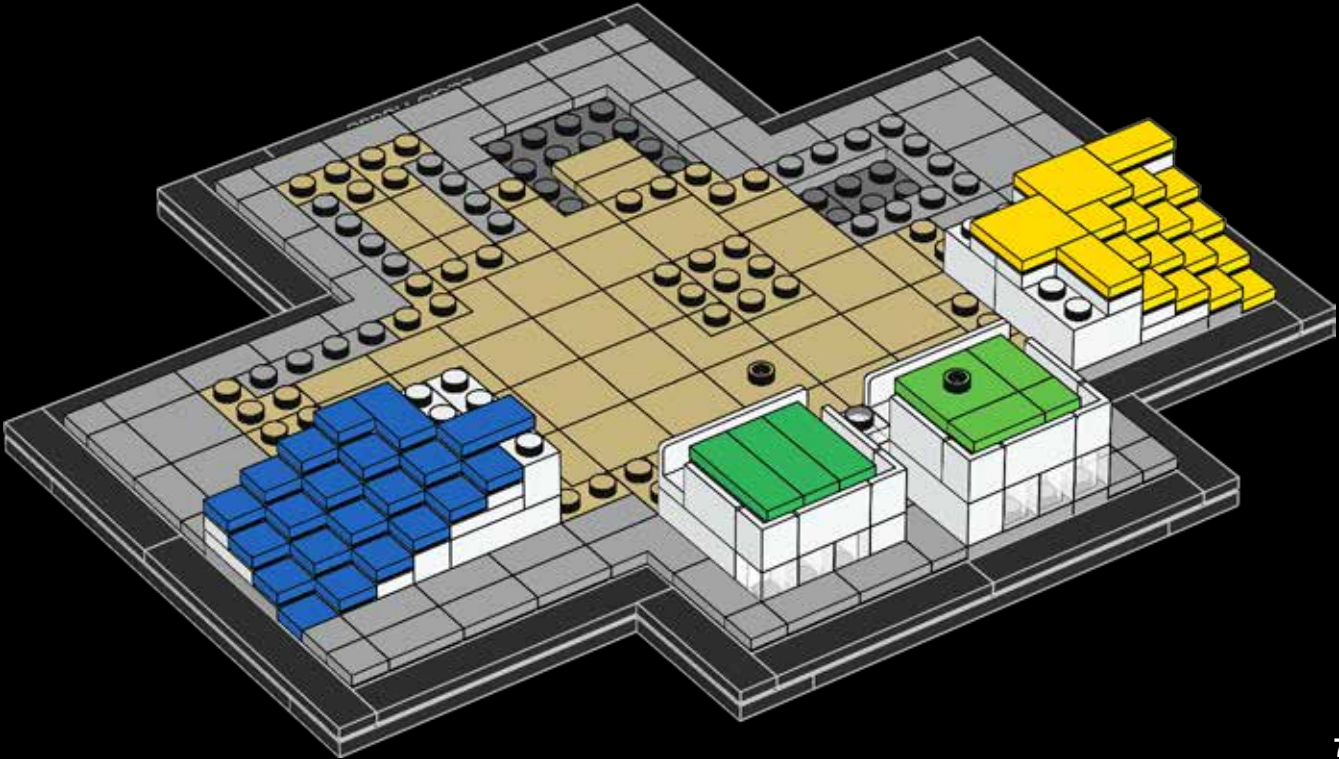



51

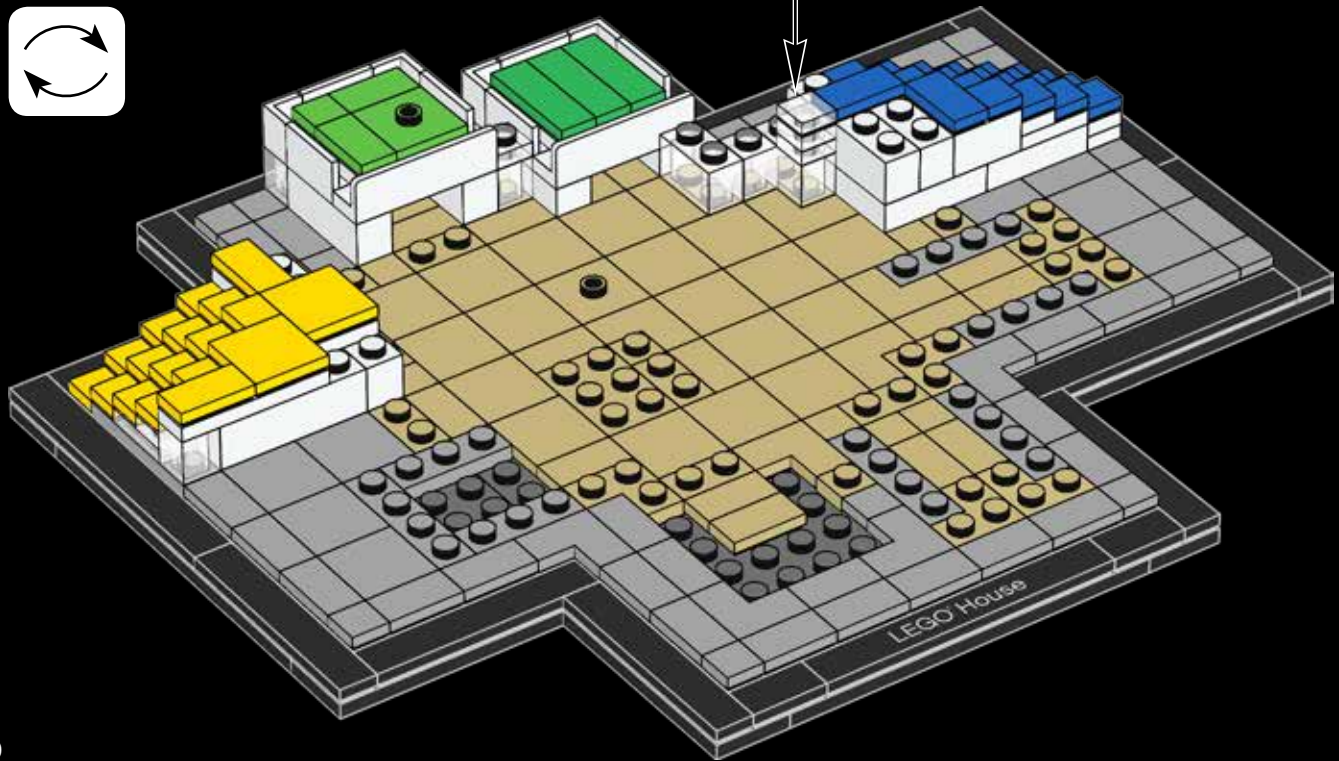
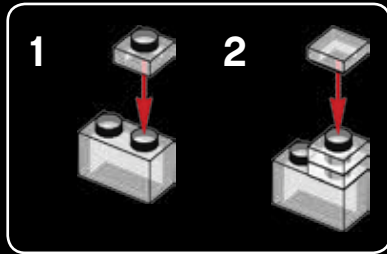



52

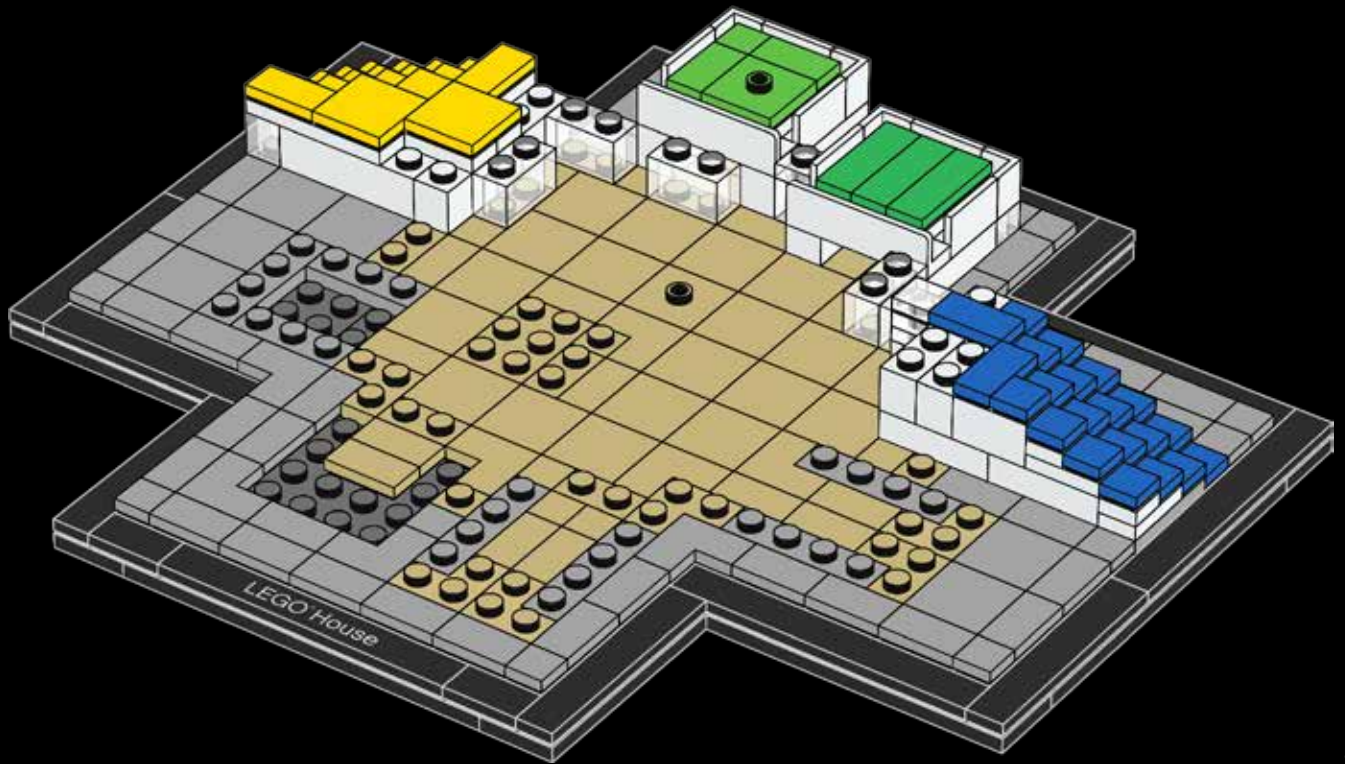

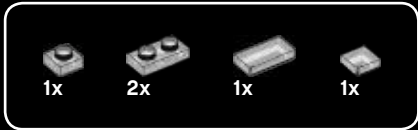

53

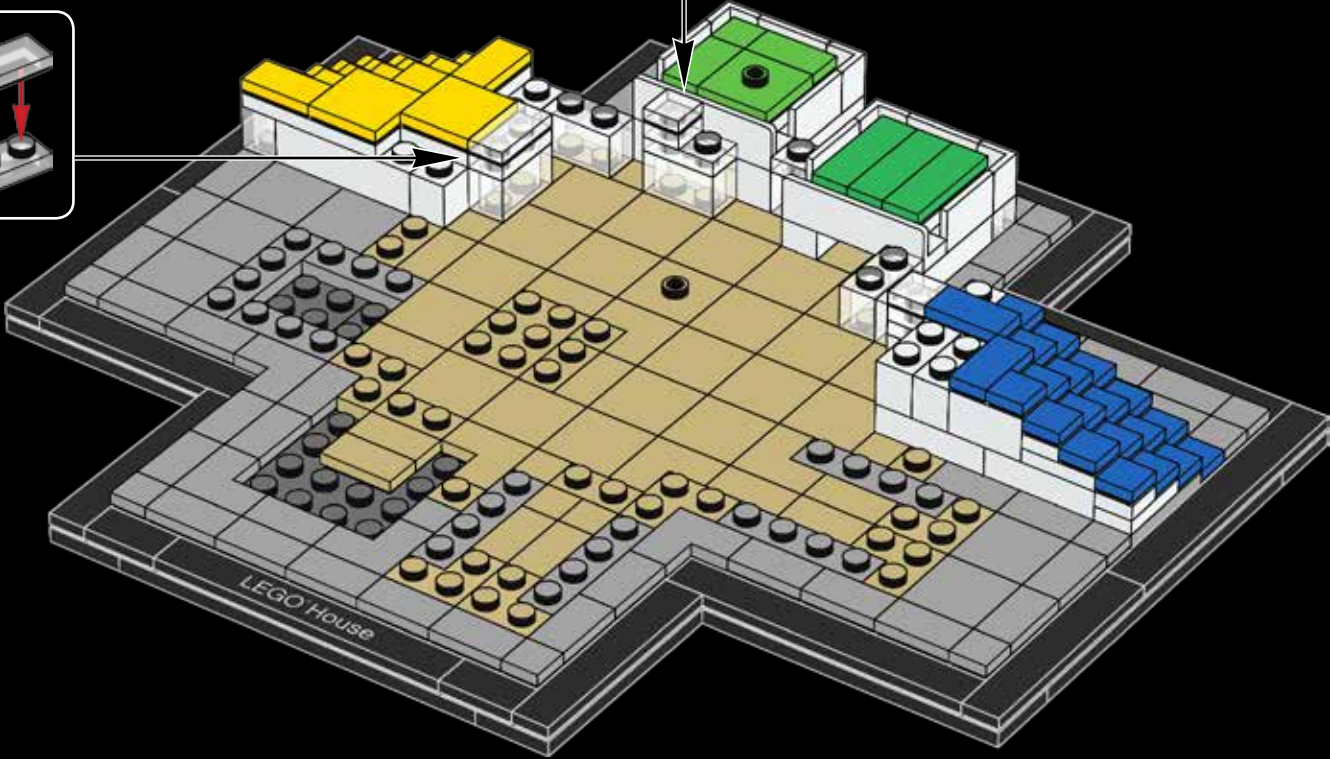
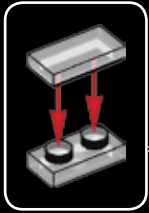
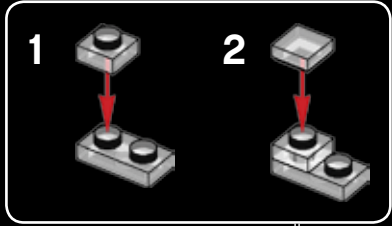



54

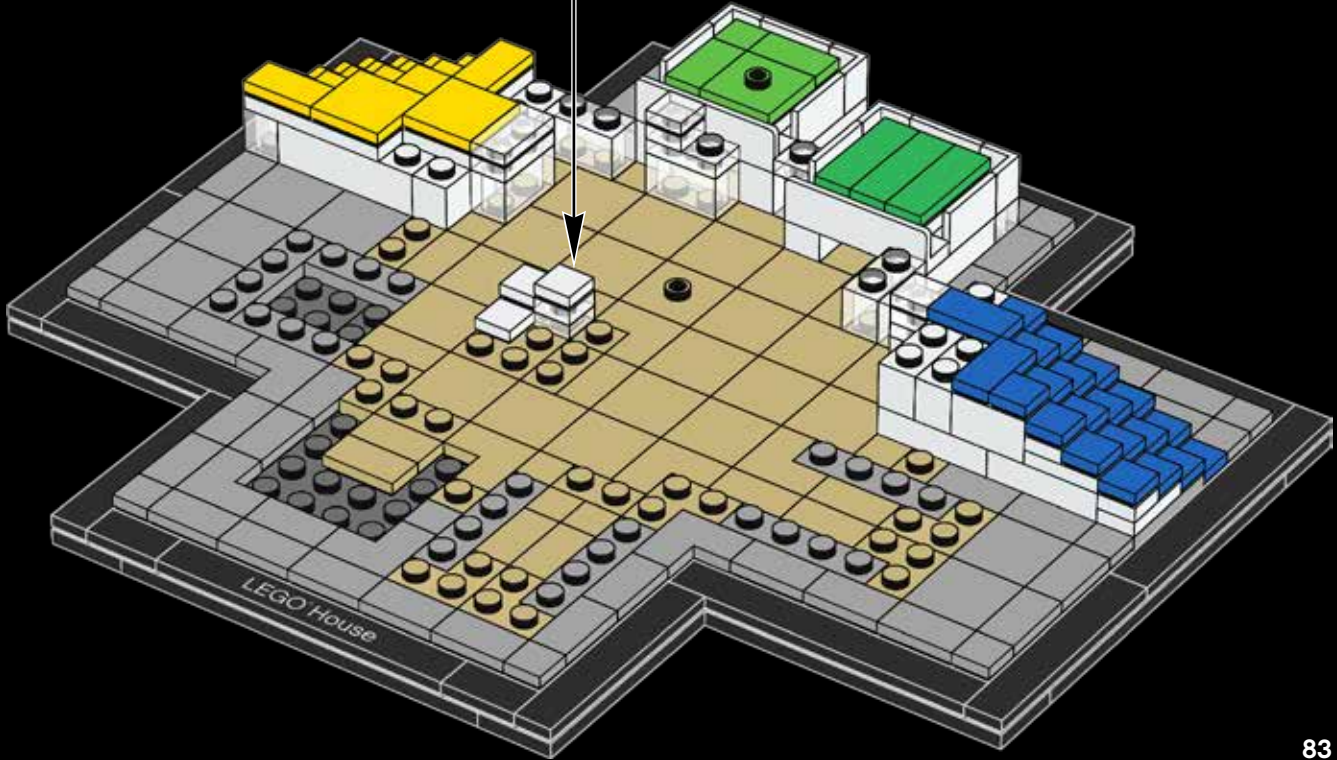
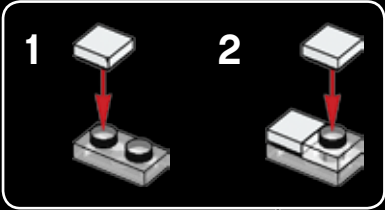

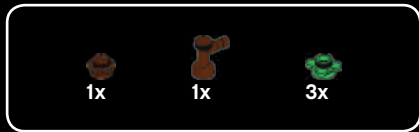

55

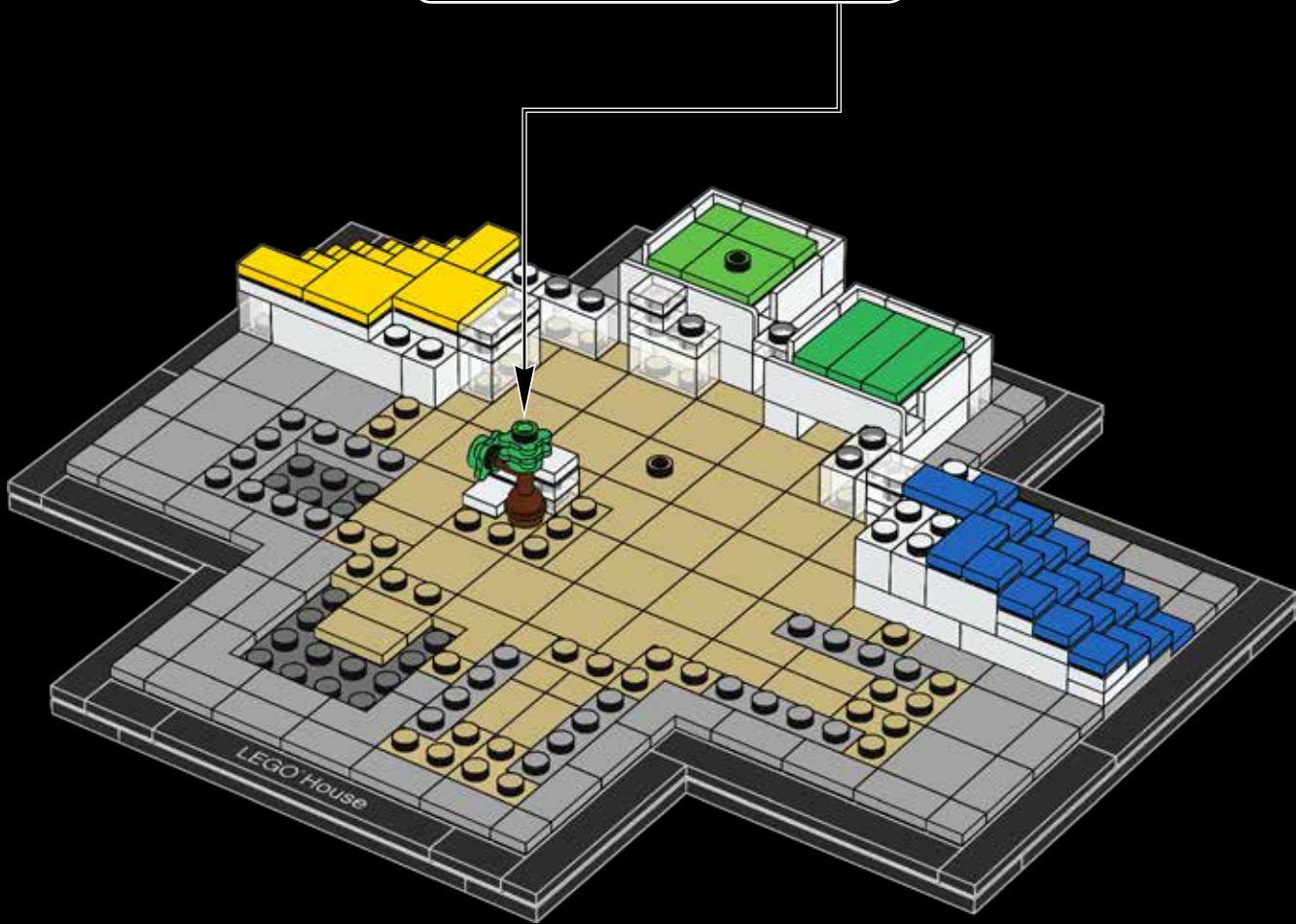
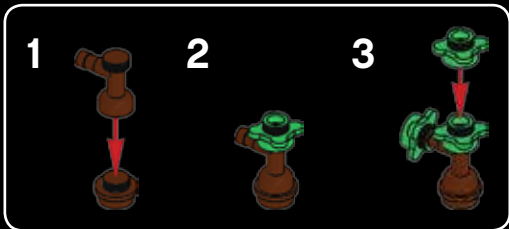



56

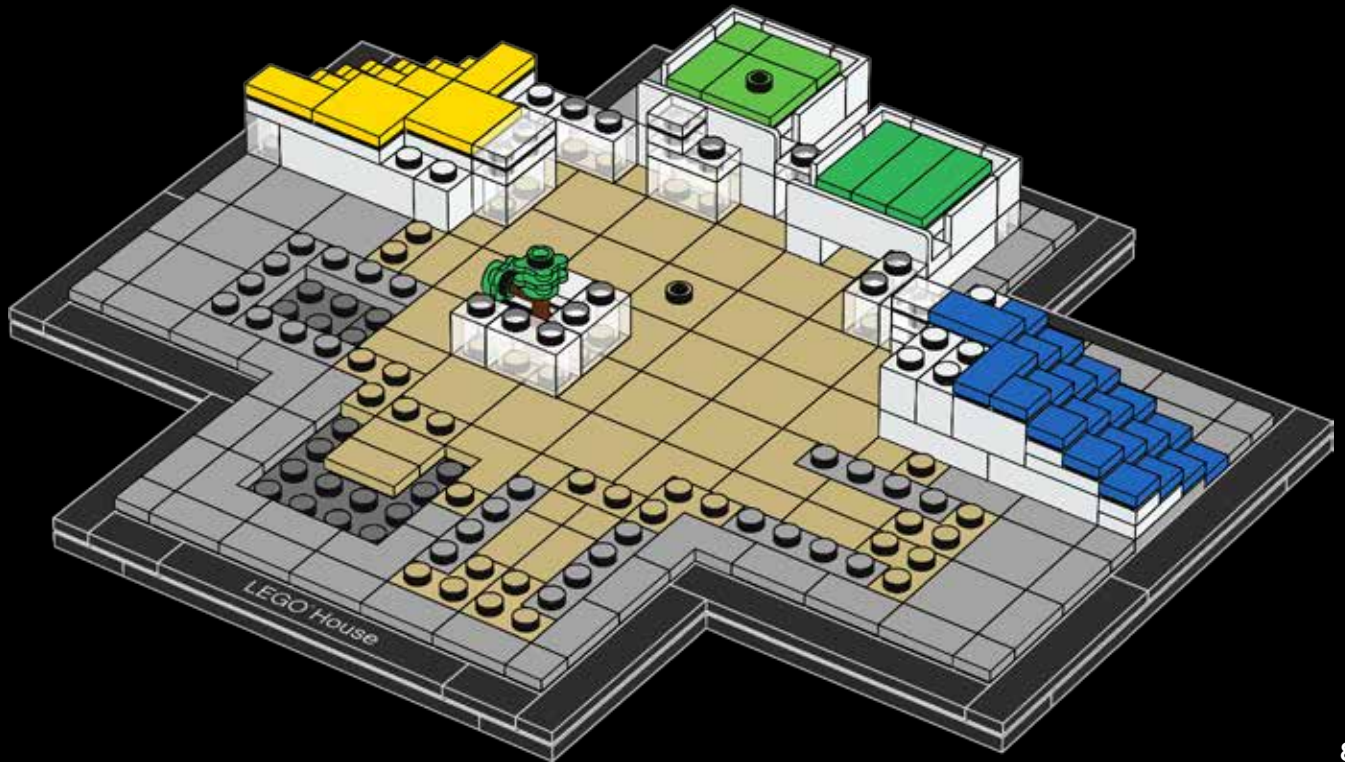

1x 1x 2x

57

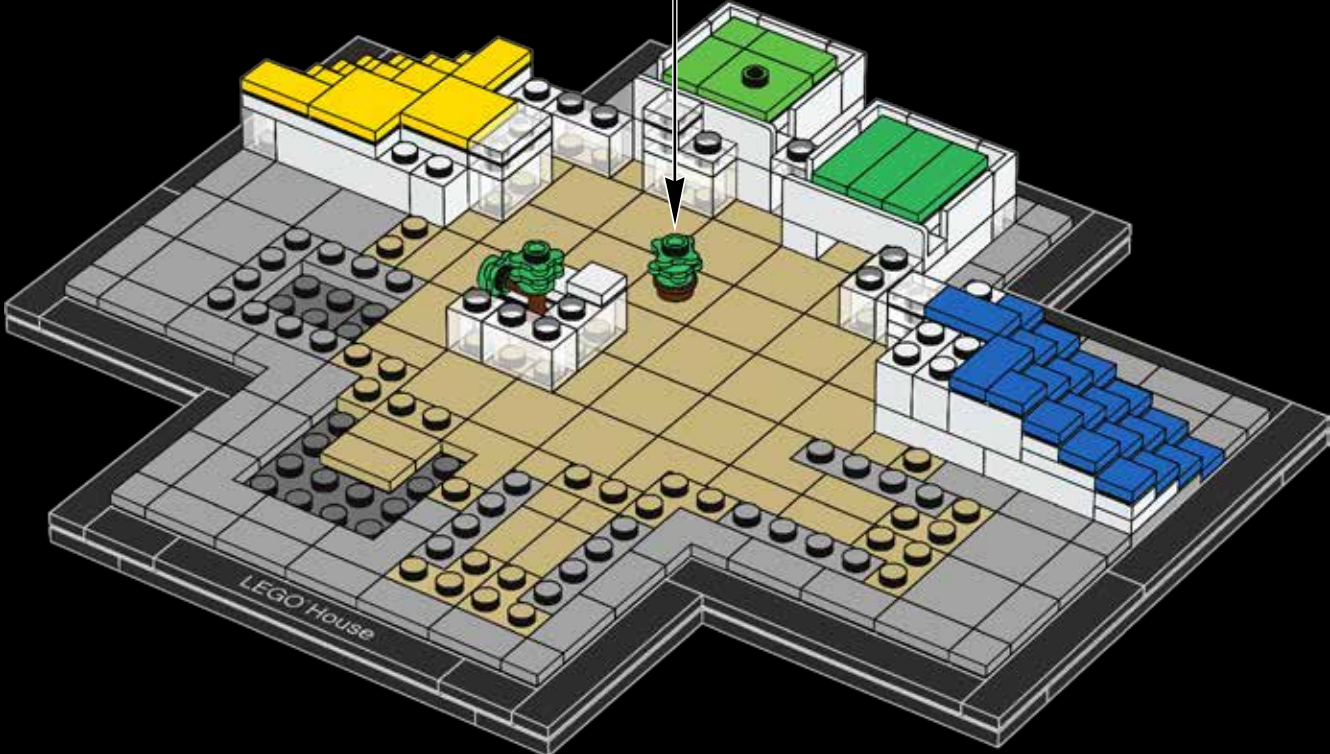



58

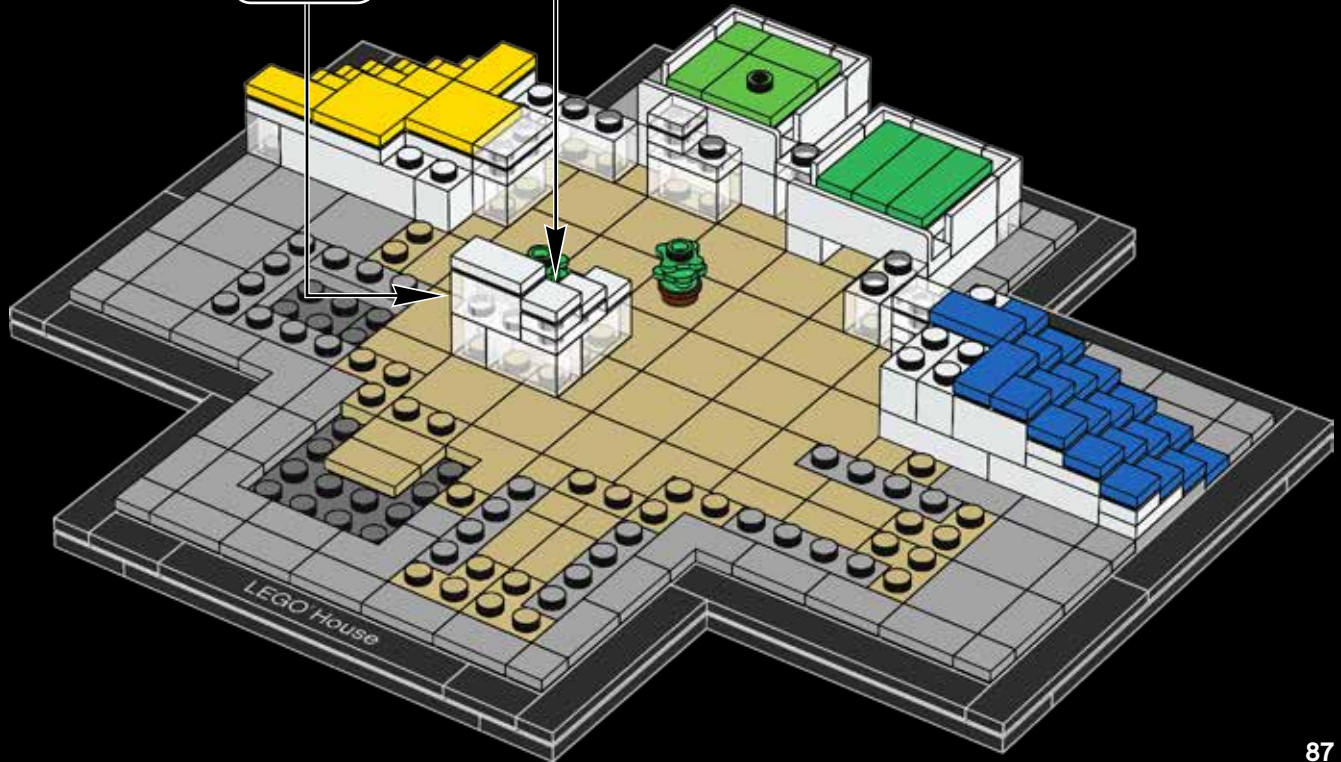
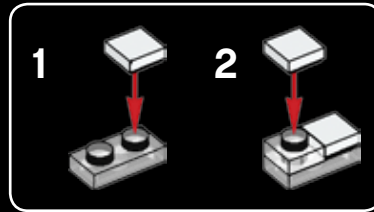
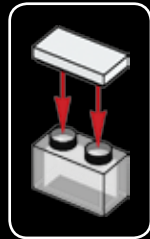

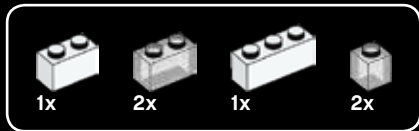

59

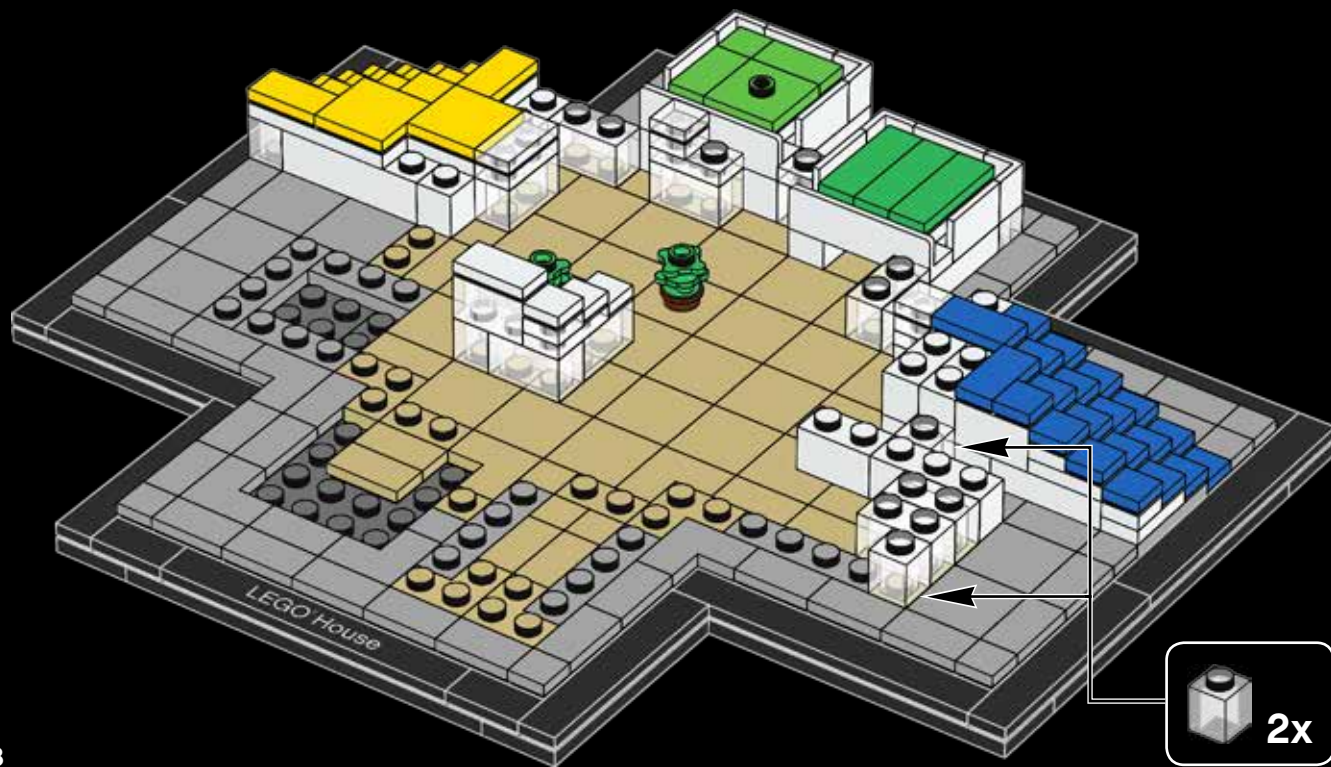



60

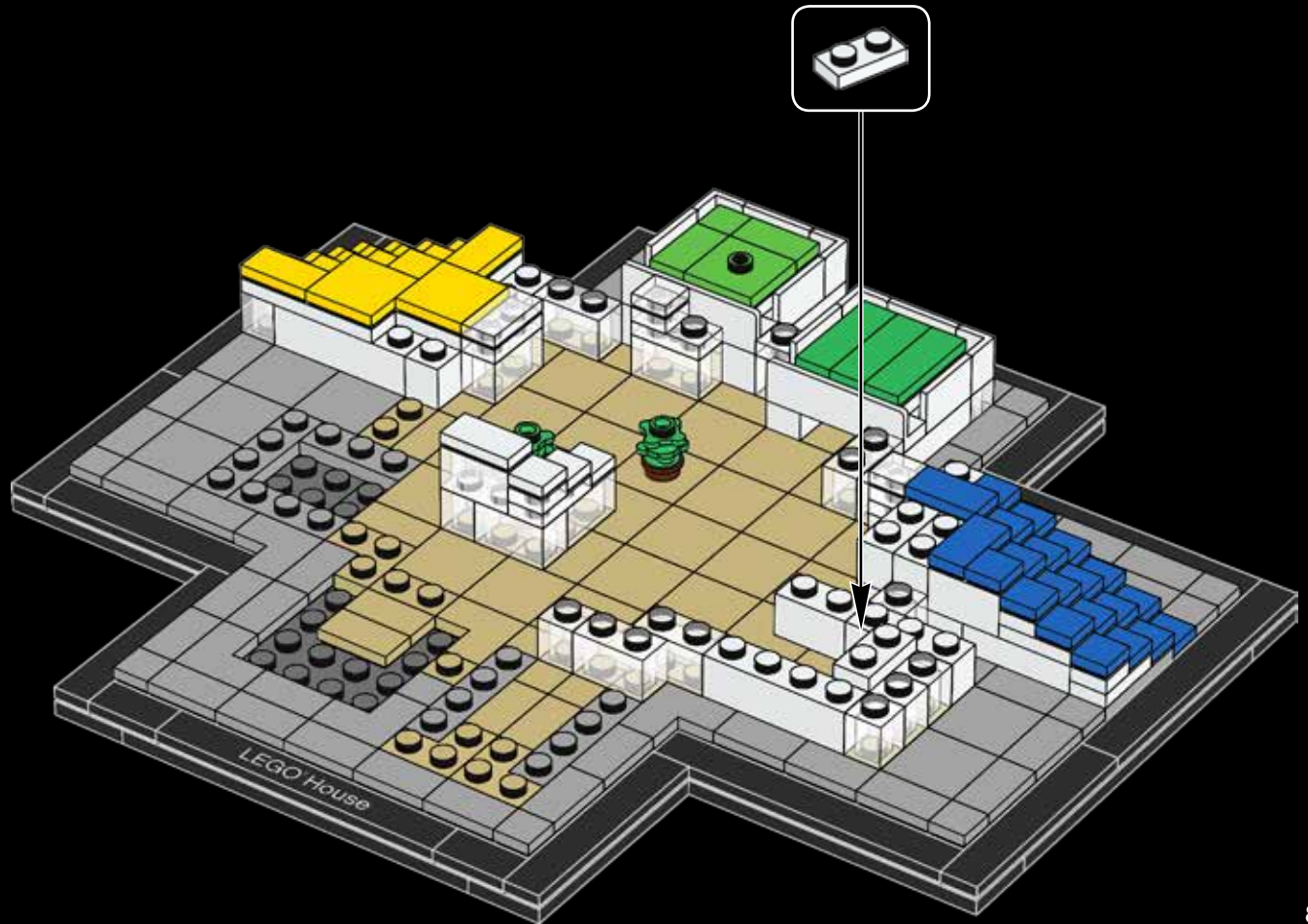

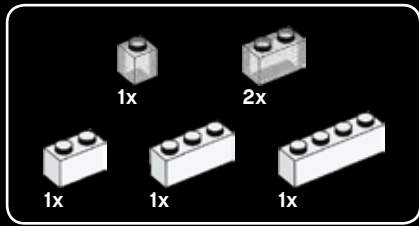

61

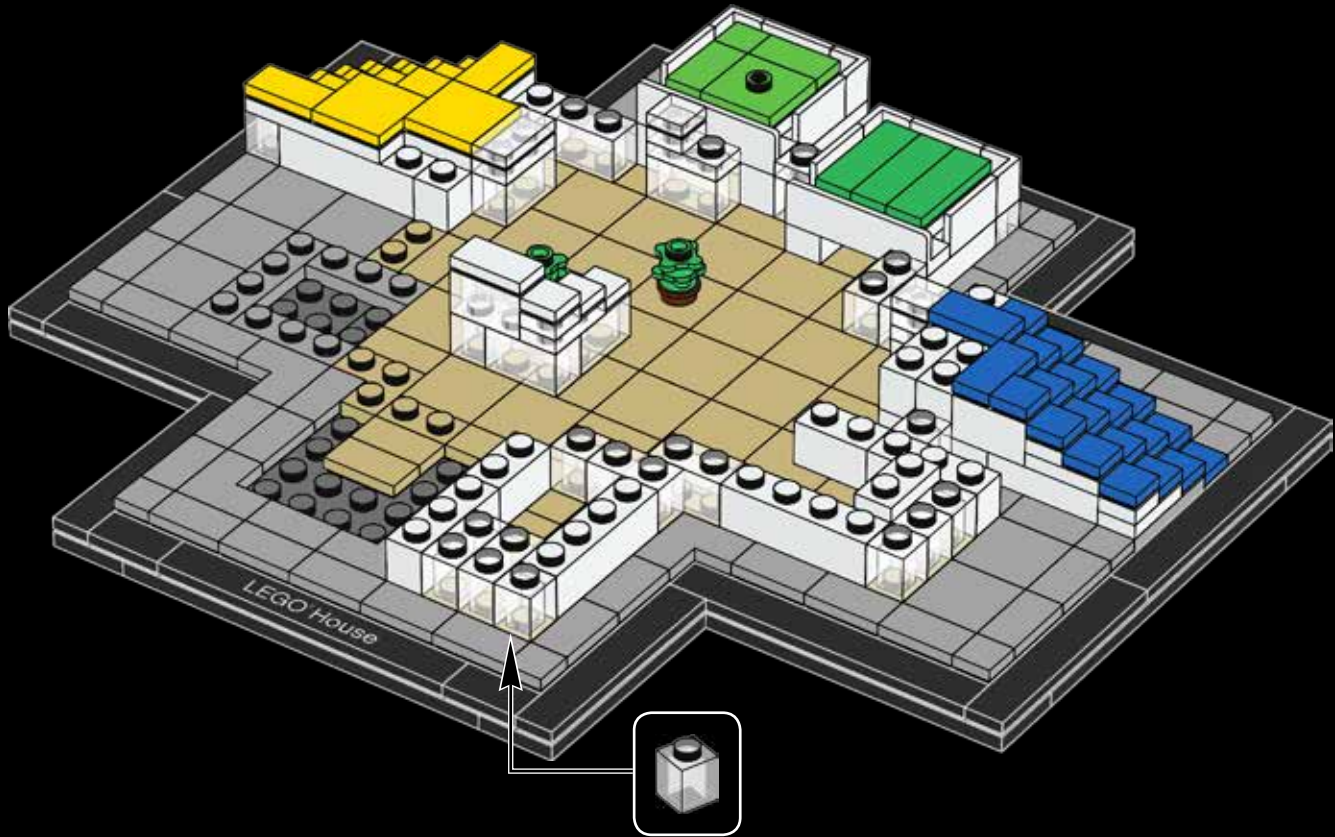



62

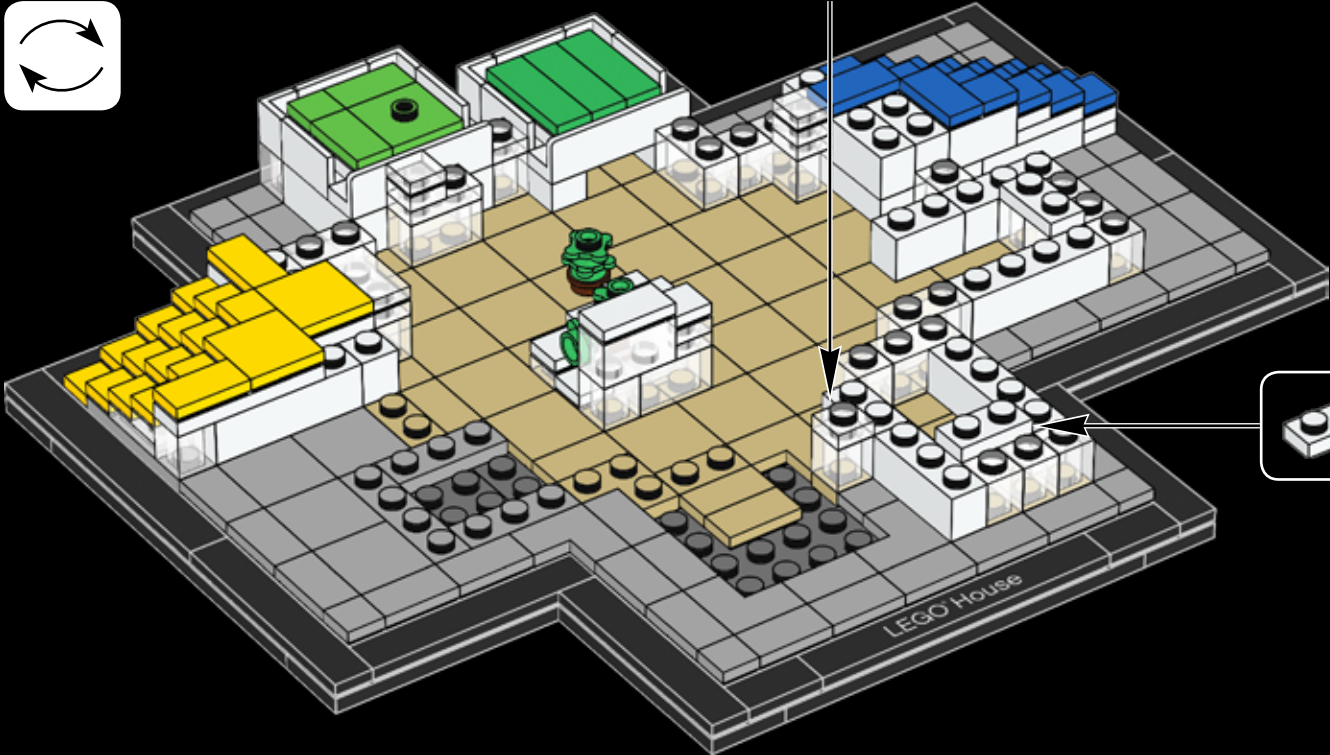
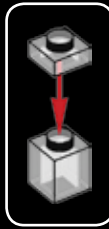
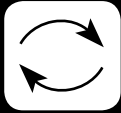



63

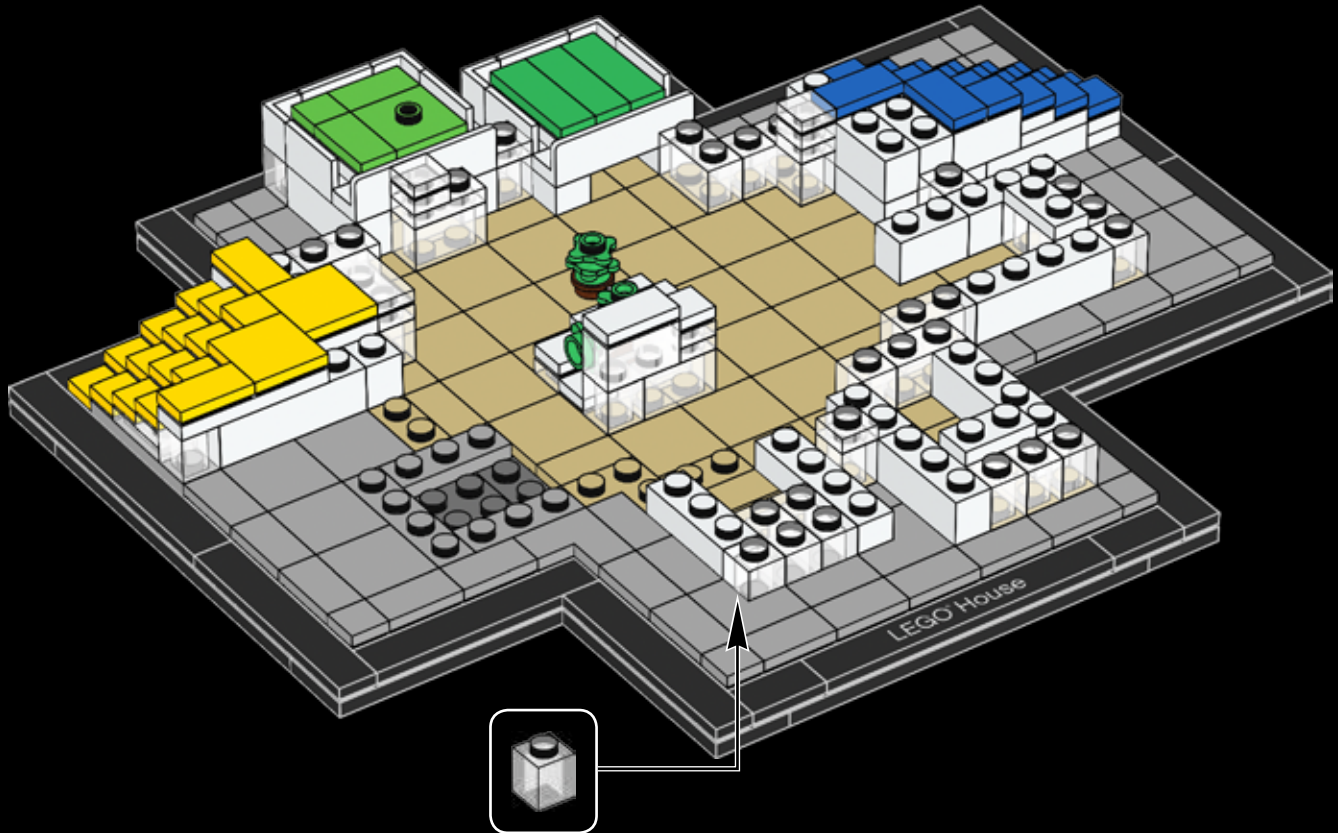



64

There are 13 different colors on the terraces, in the palette of yellow, blue, green, red and white.

Il y a 13 couleurs différentes sur les terrasses, dans une palette de jaune, bleu, vert, rouge et blanc.

Las terrazas exhiben 13 colores distintos de una paleta de amarillo, azul, verde, rojo y blanco.

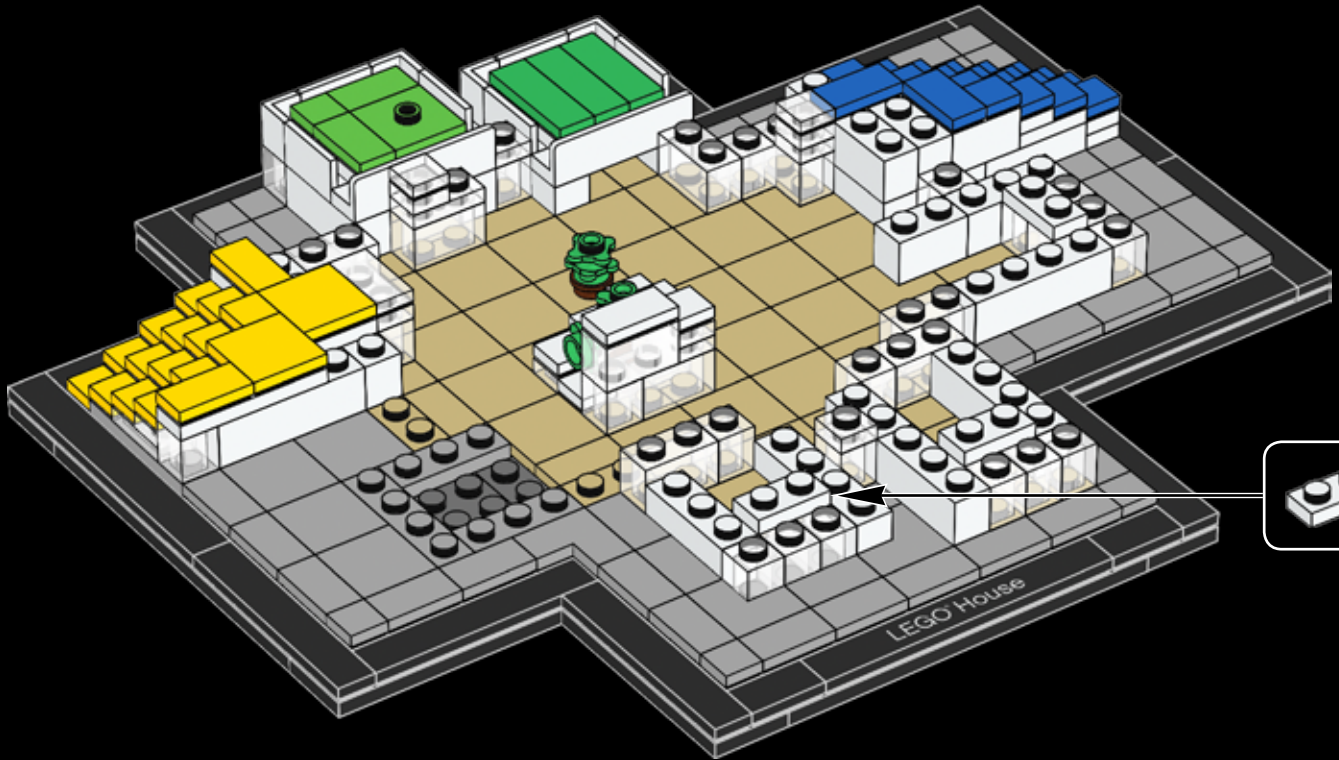

1x 2x 2x

65

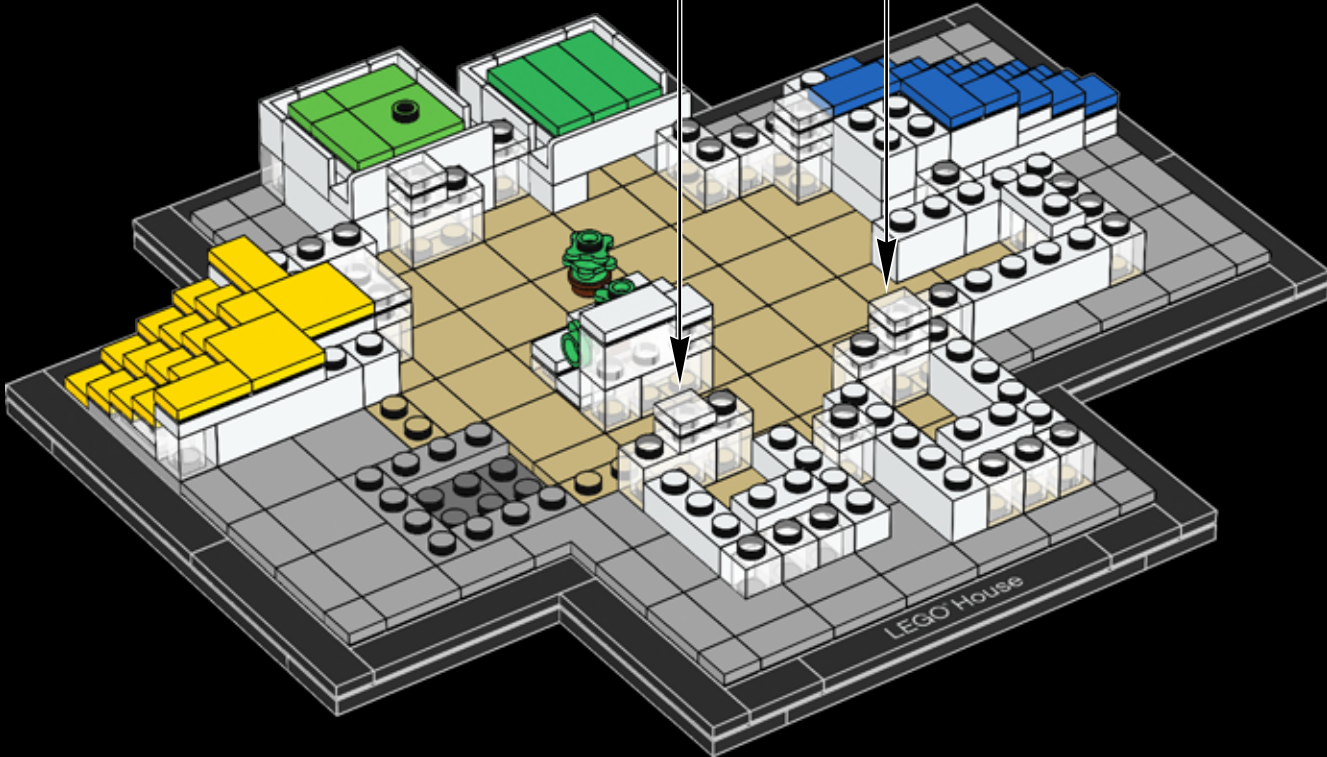
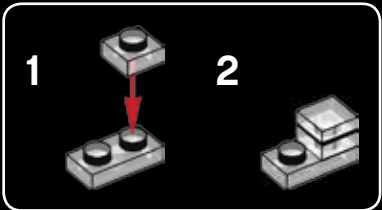
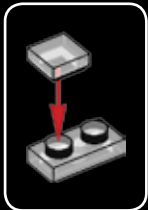



66

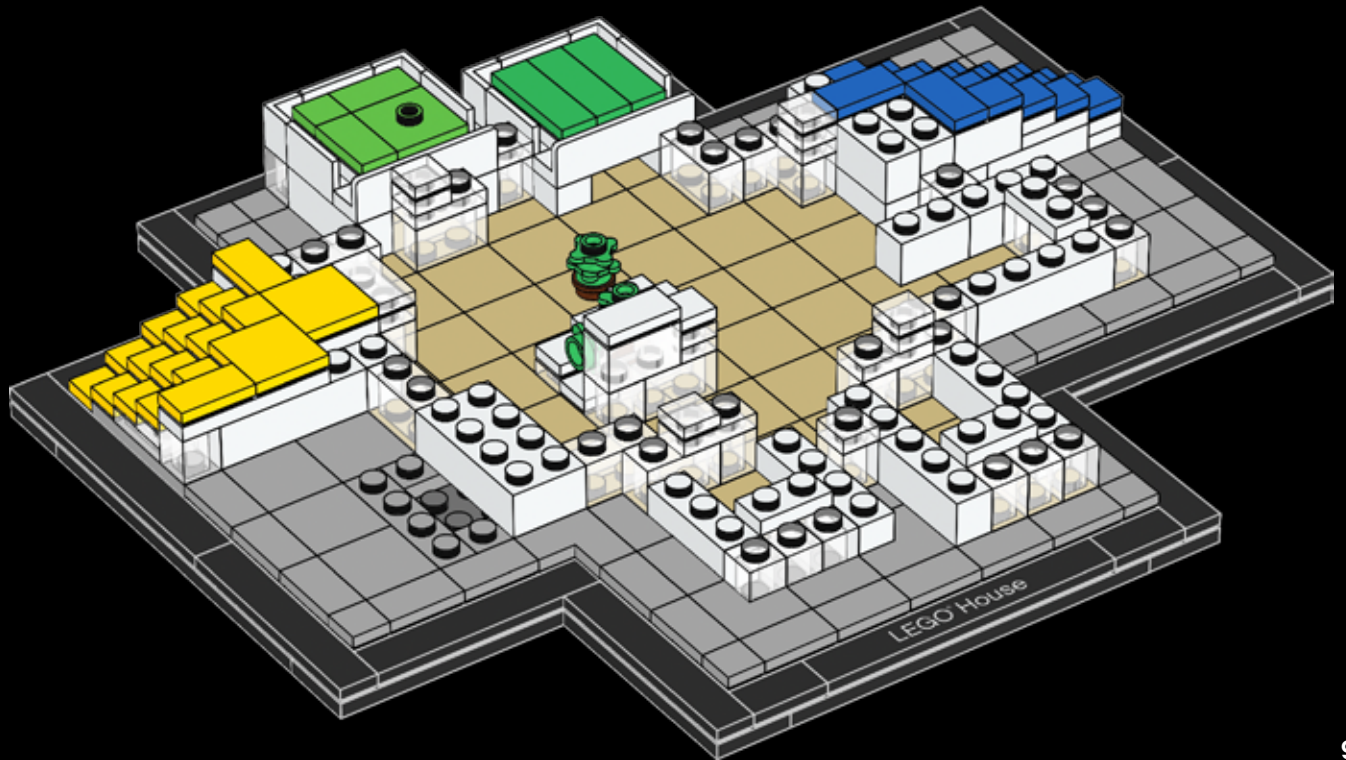



67

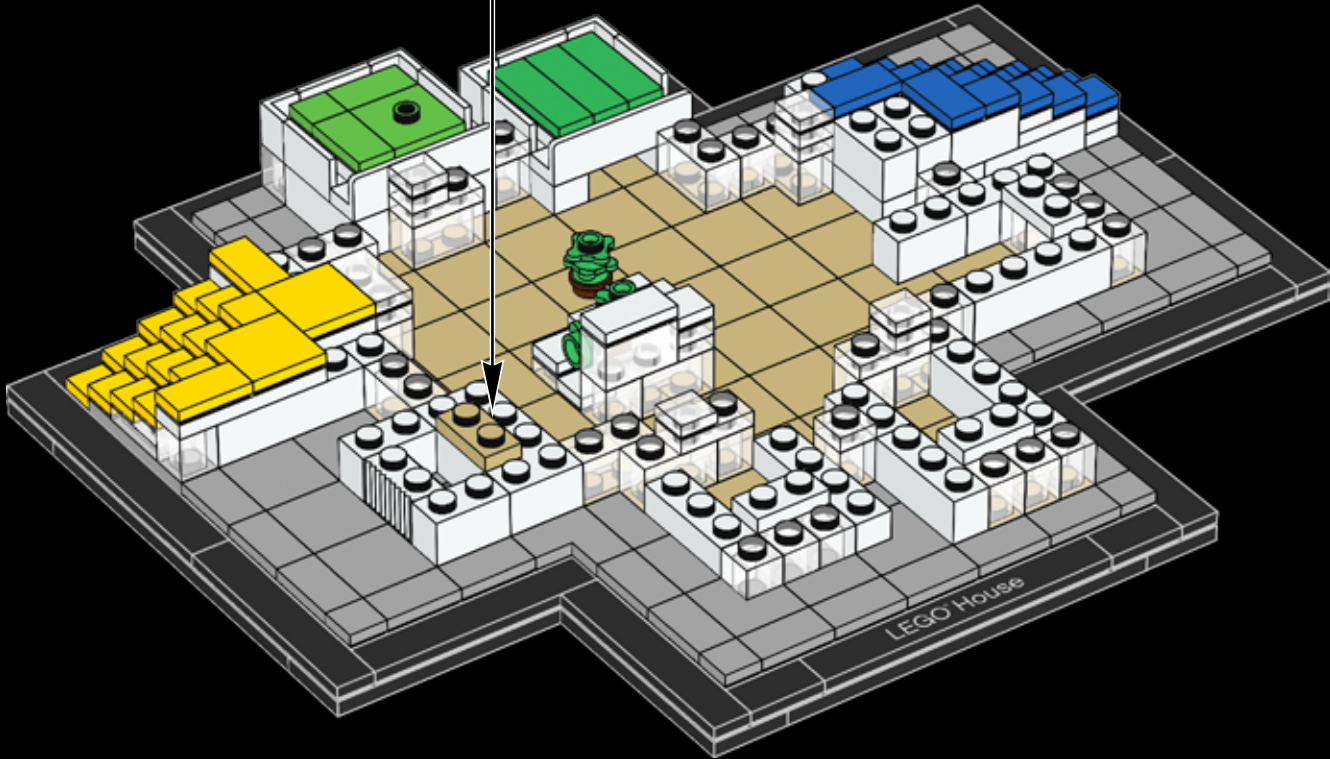

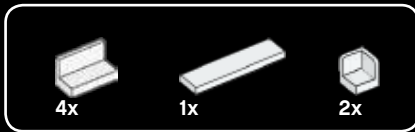

68

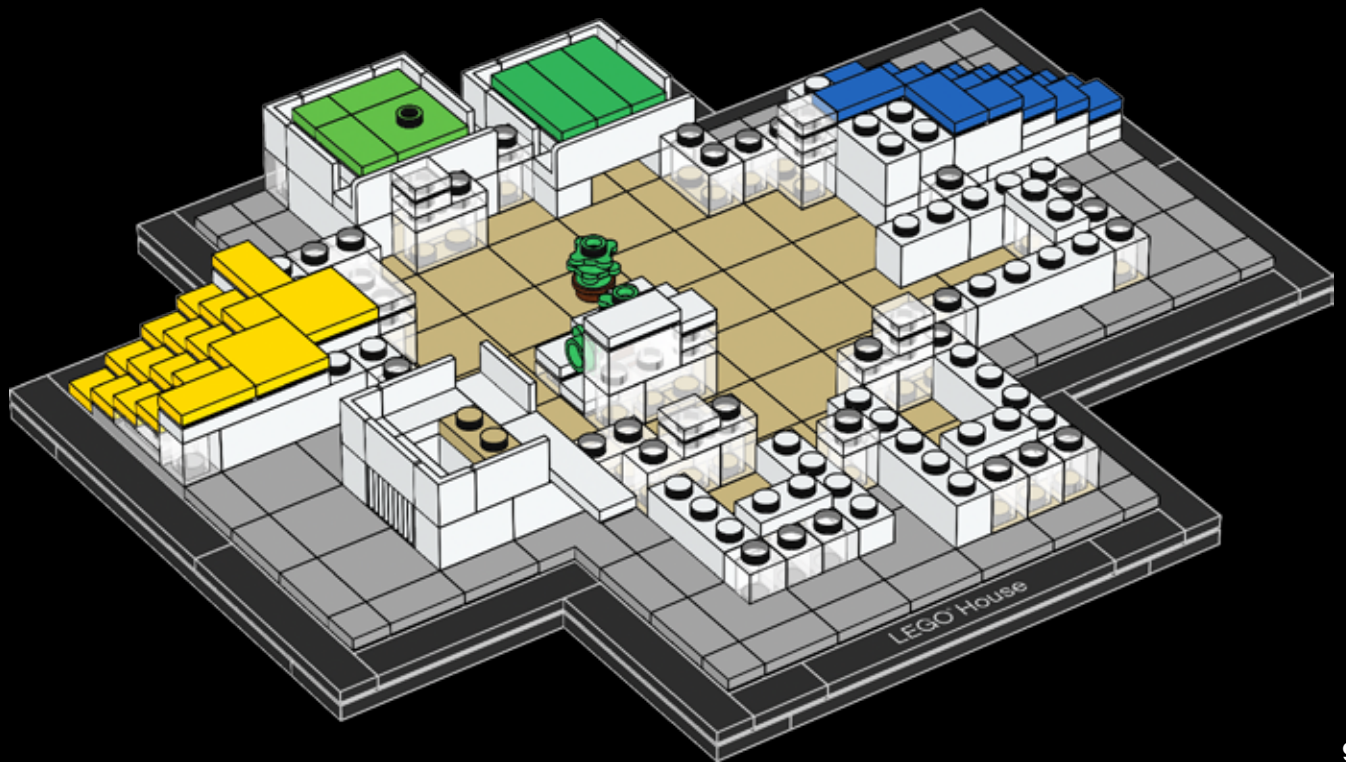

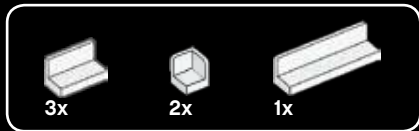

69

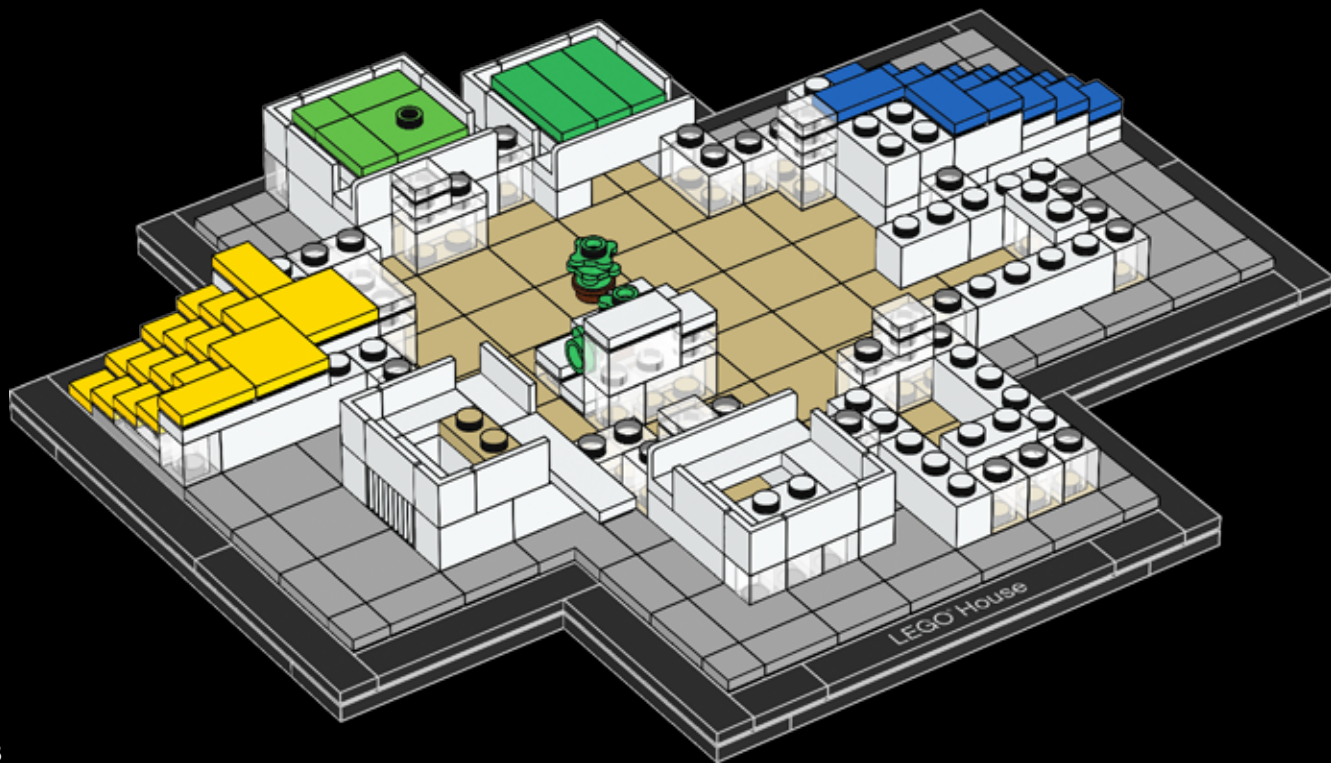

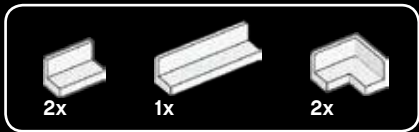

70

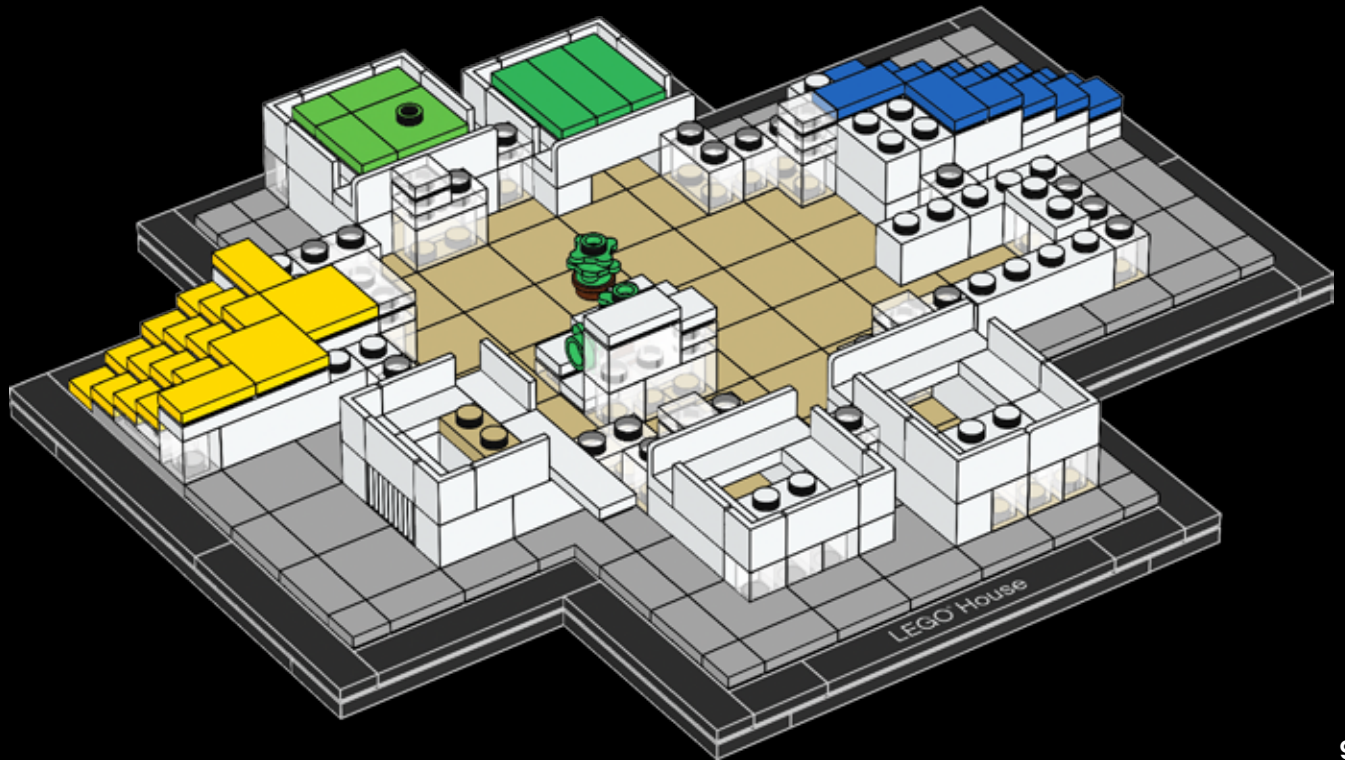

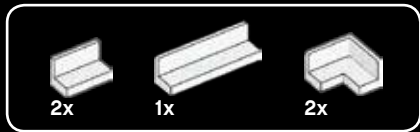

71

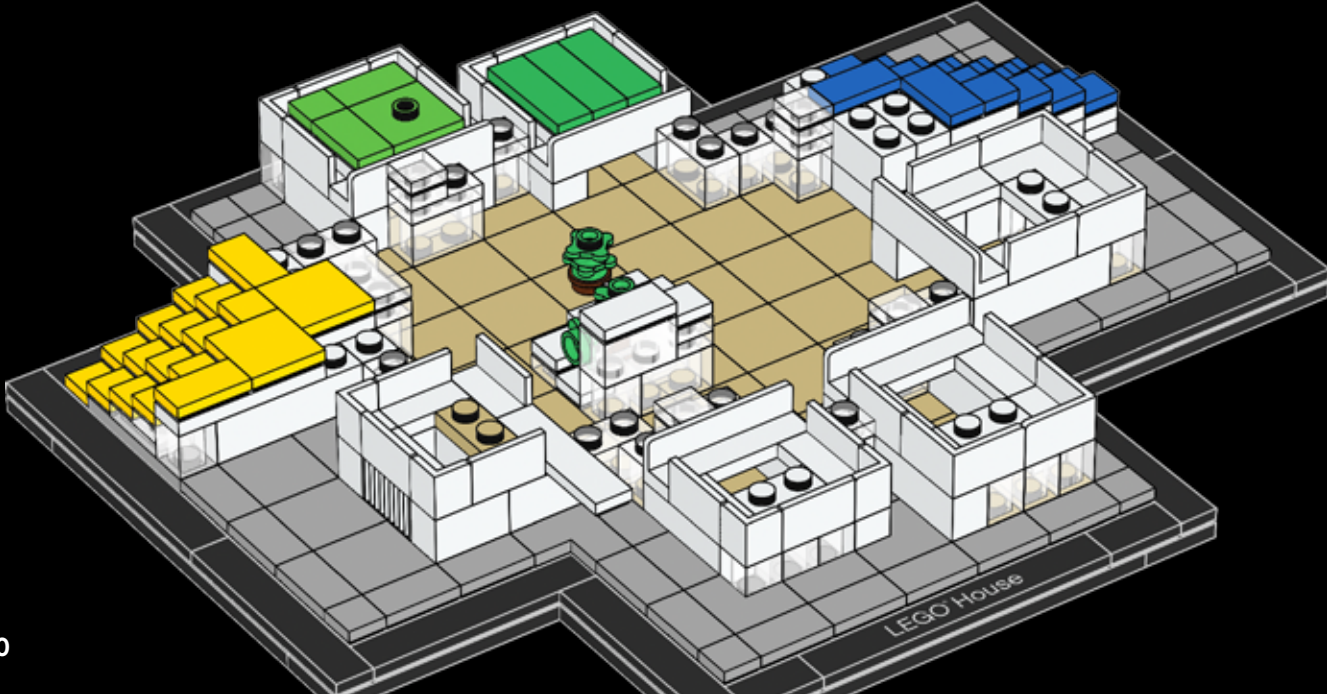

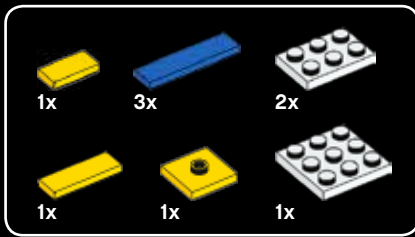

72

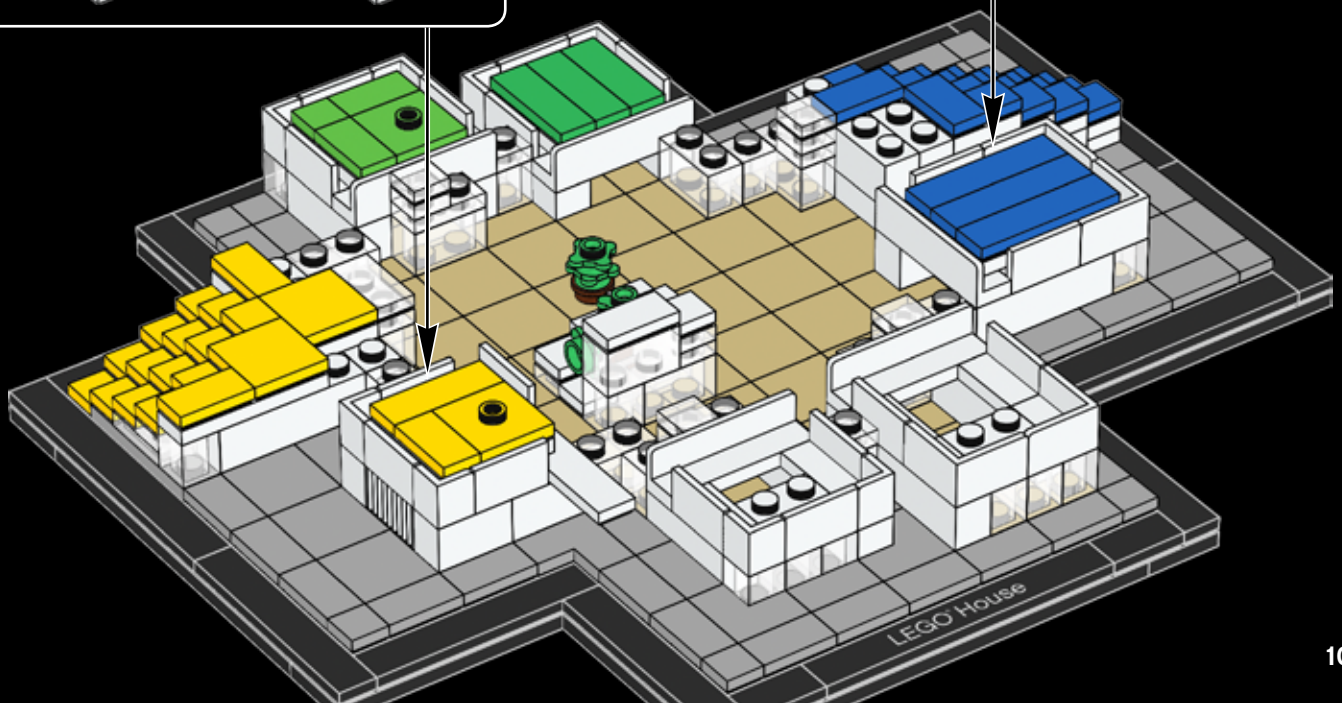
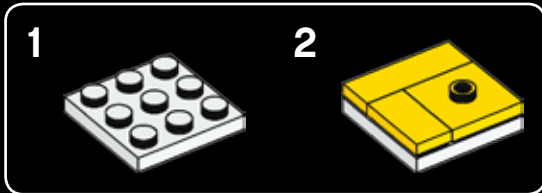
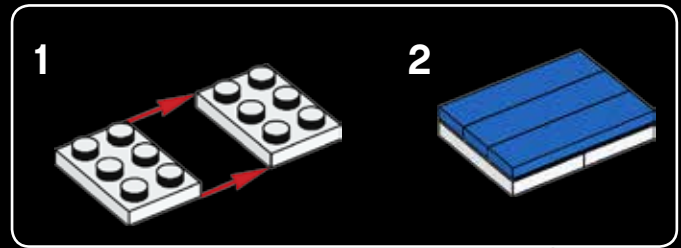

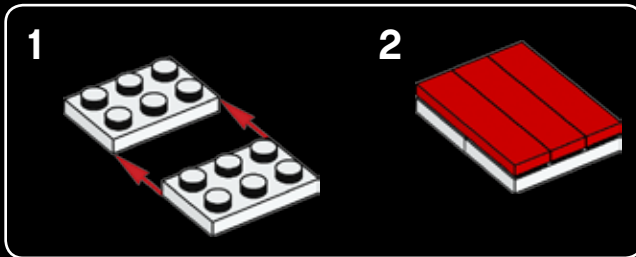
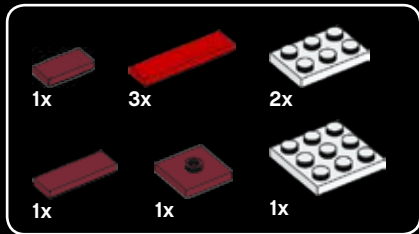

73

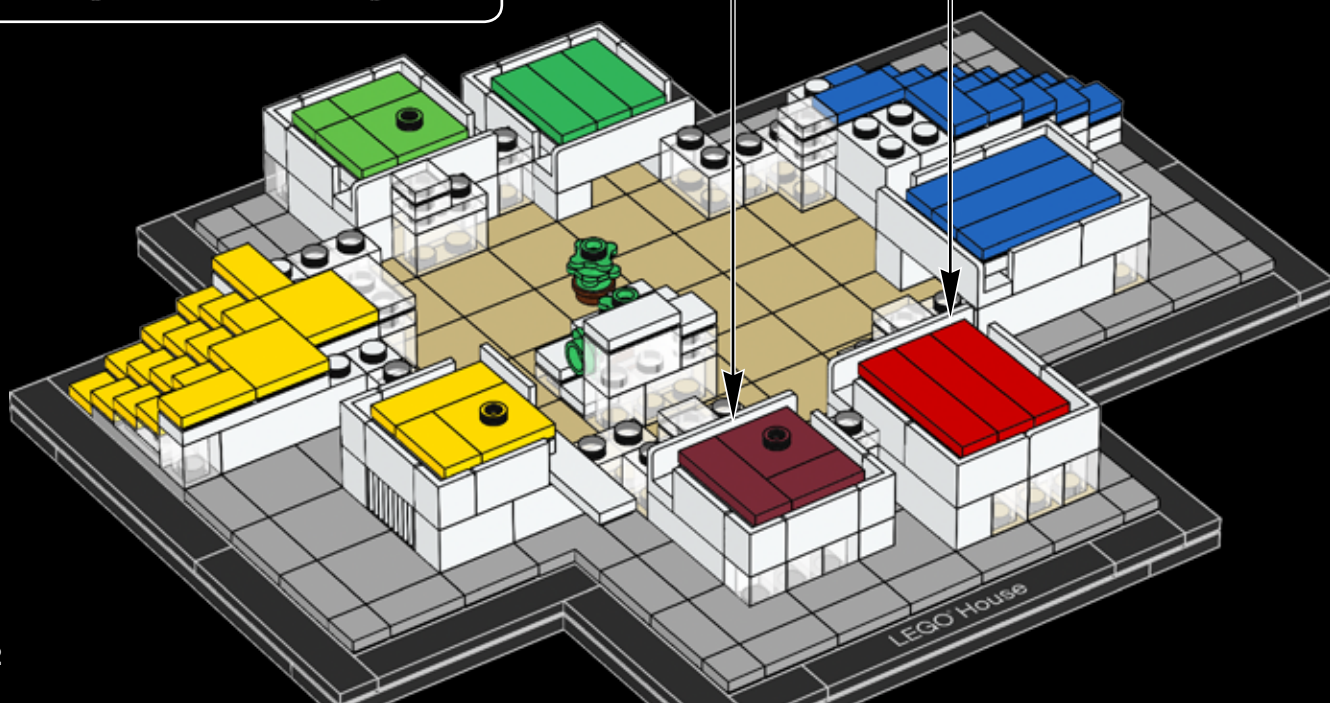
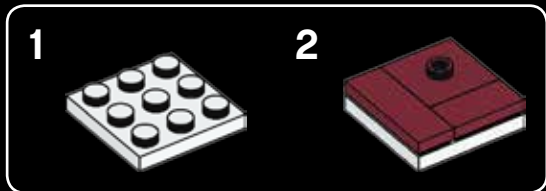



74

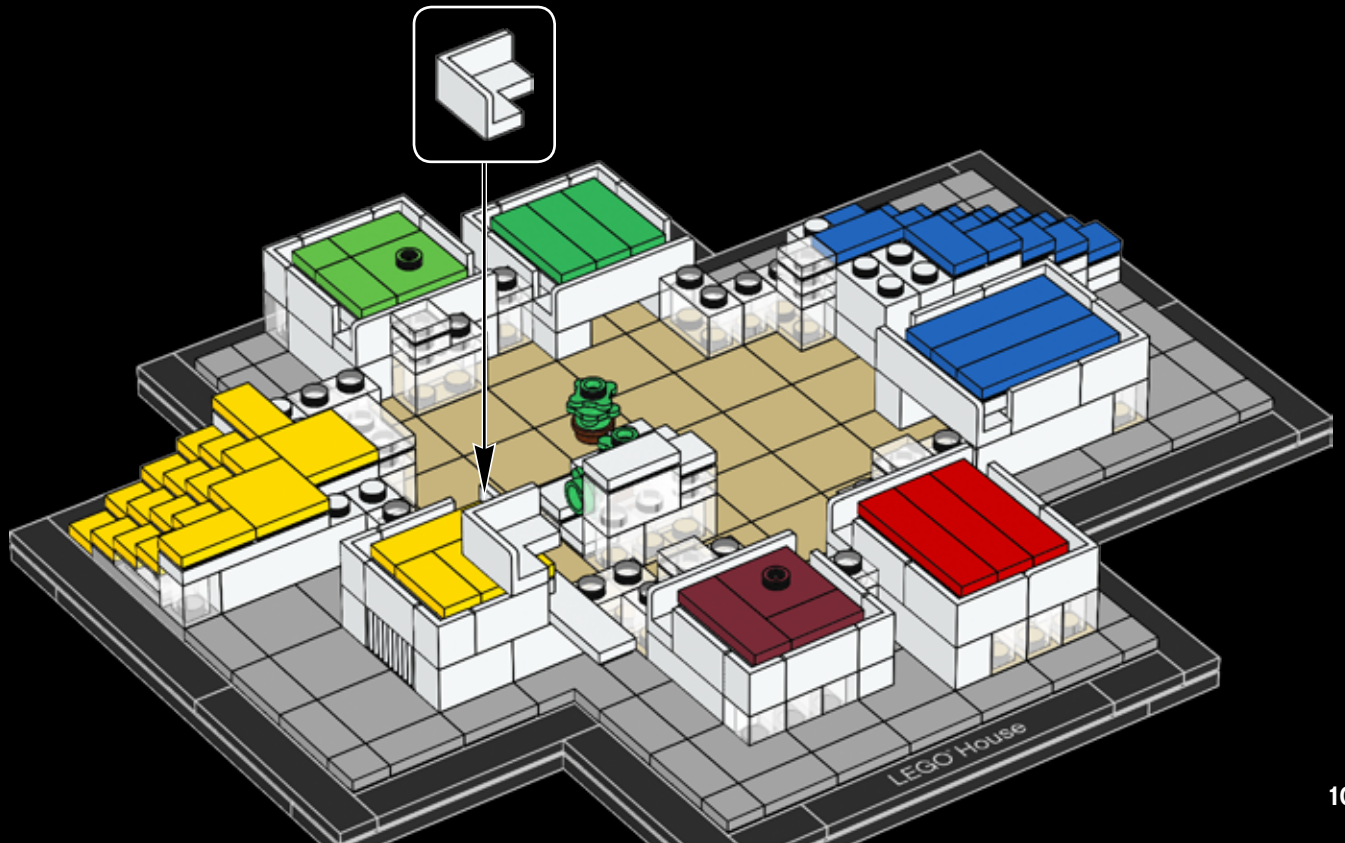



1x



1x

75



2x

76

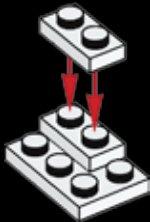

1x

77



1x

78





79



80



81

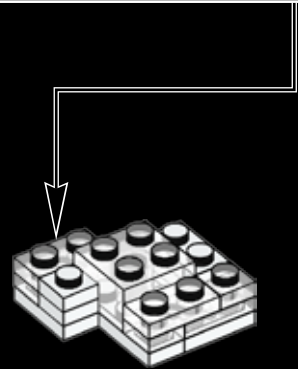
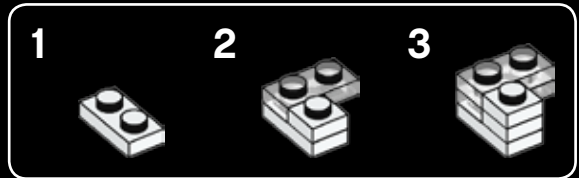



4x

82



3x



1x

83

1



2

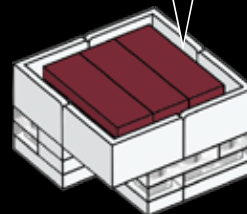

84

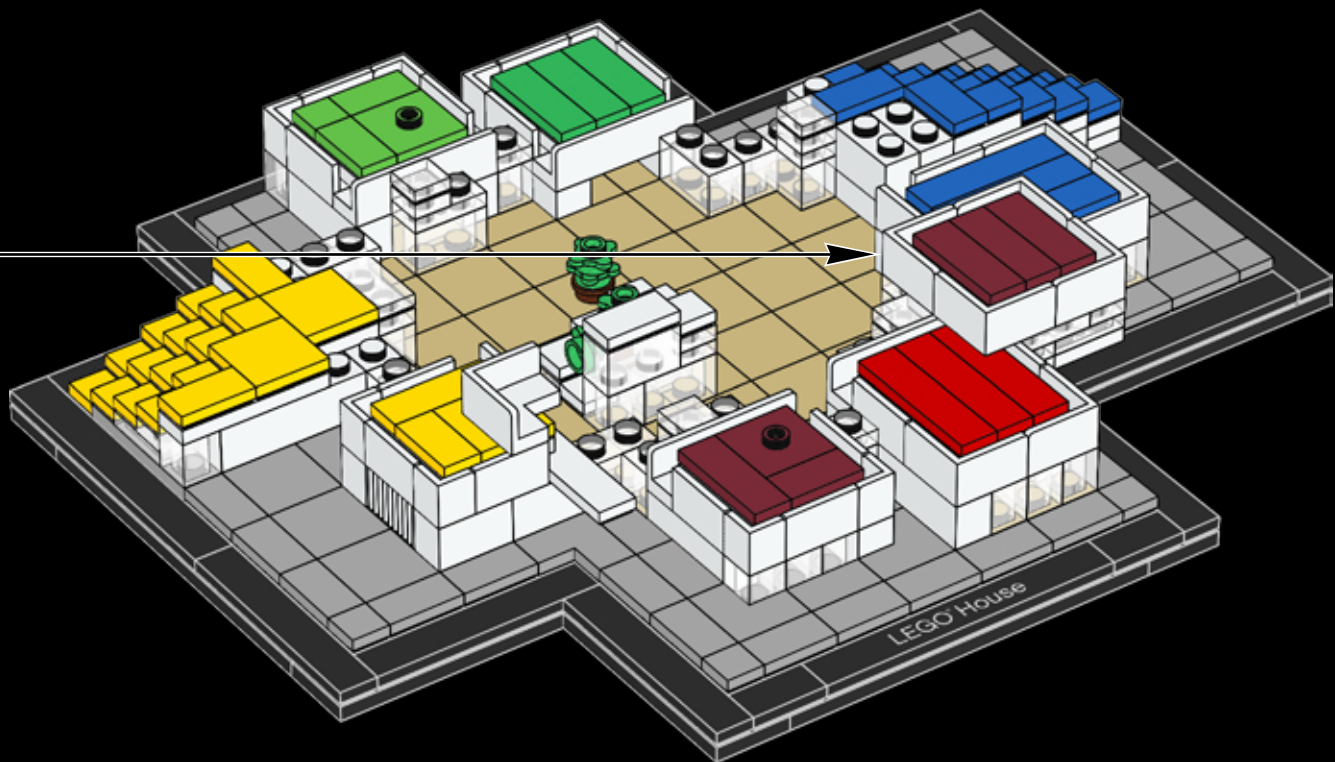

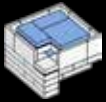

1x

1x

85

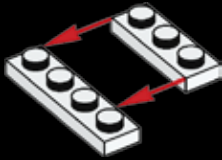

1x

86



1x

1x

1x

87

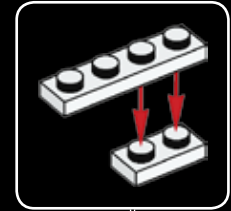

1x



1x

88



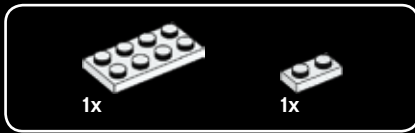

89

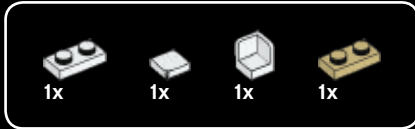
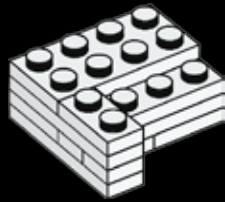

90

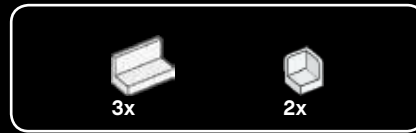
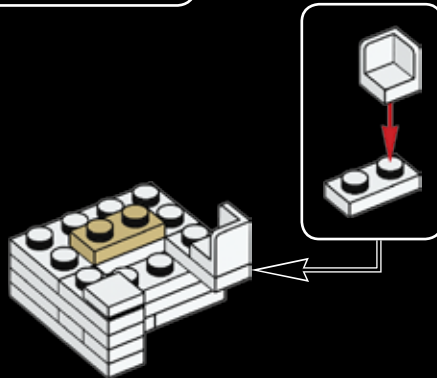

91

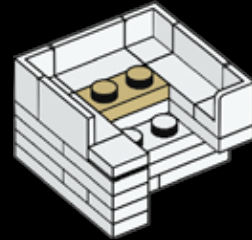



92

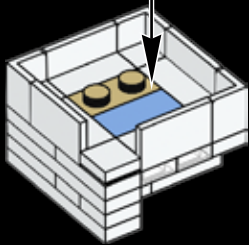
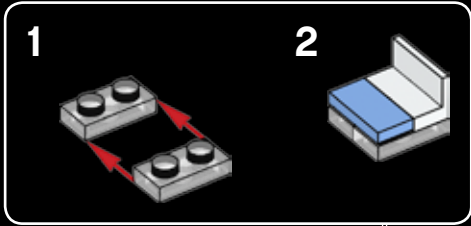

93

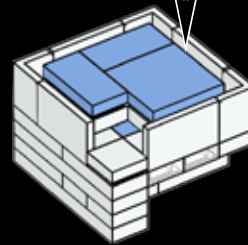
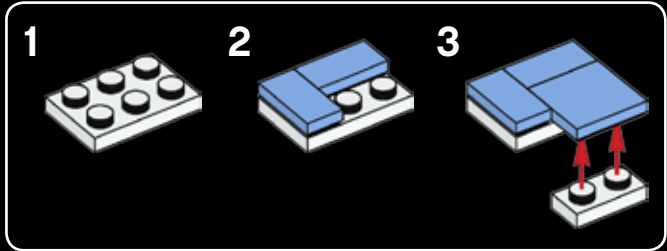

94

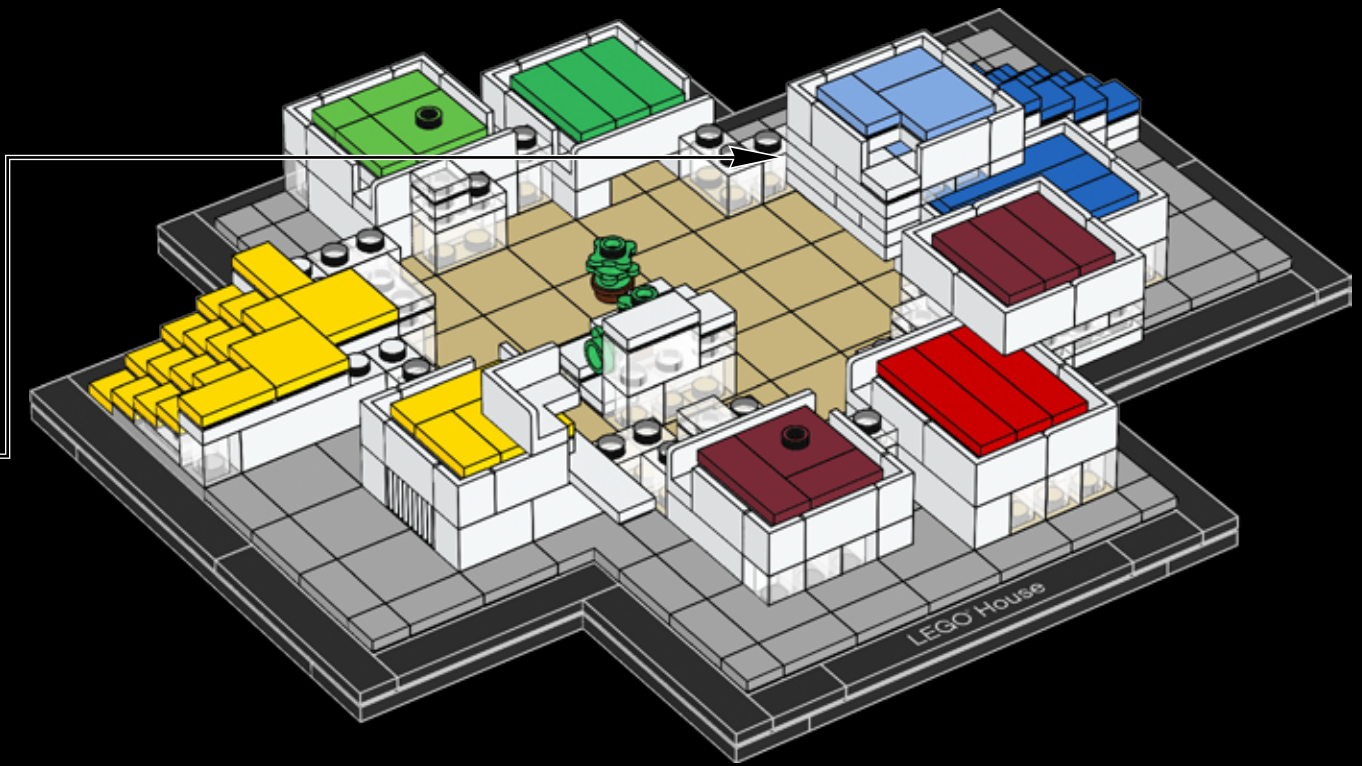



1x



1x

95

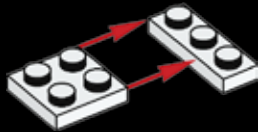

1x



1x



1x

96



1x



1x

97

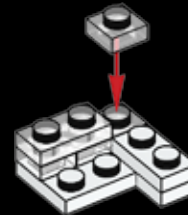

1x

98





99



100

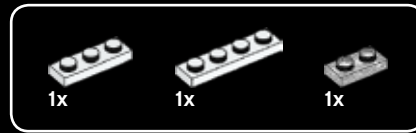

101

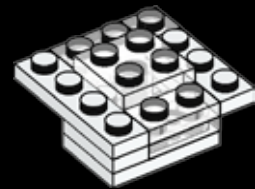



4x

102



1x



3x

103

1



2

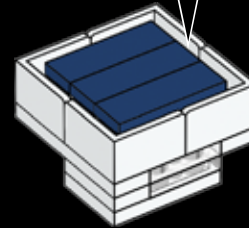
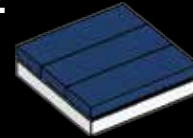

104

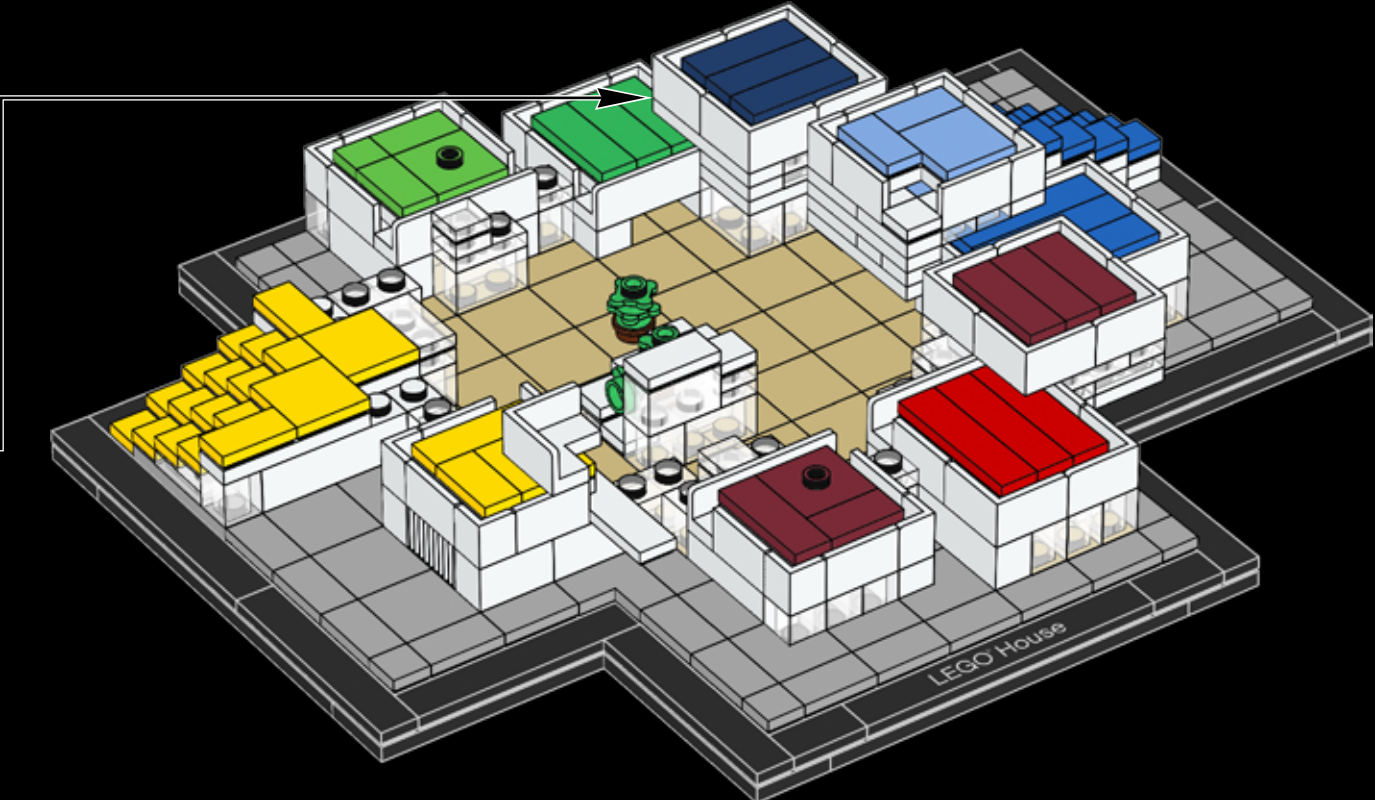



105



106

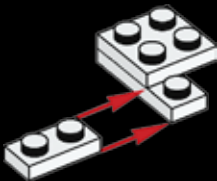

107



108

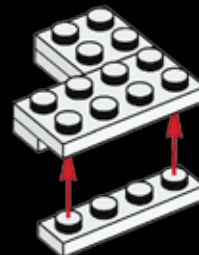

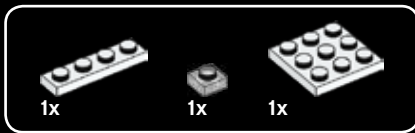

109



110



111

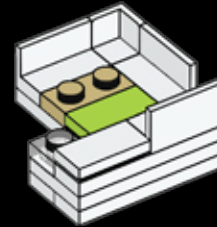



112

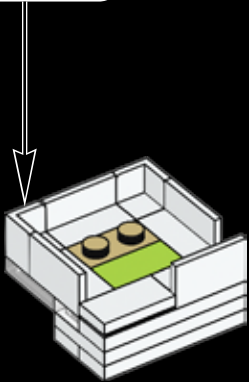
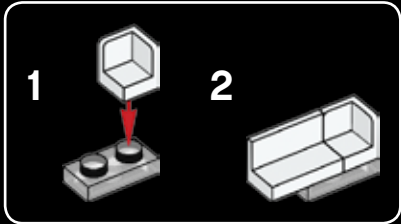

113

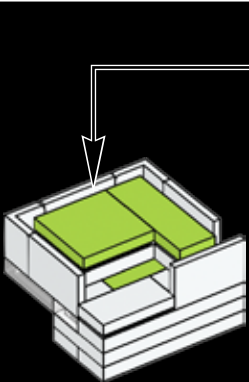
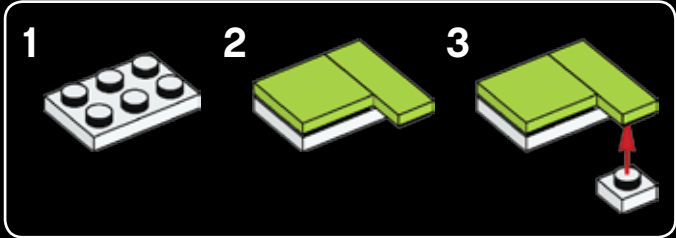

The surfaces of the colored terraces are made of leftover materials from sneaker production by several different international sports brands.

Les surfaces des terrasses colorées sont fabriquées avec les restes de la production de chaussures de sport de plusieurs marques internationales.

Las superficies de las terrazas coloreadas están confeccionadas con materiales sobrantes de la producción de zapatillas de varias marcas deportivas internacionales.

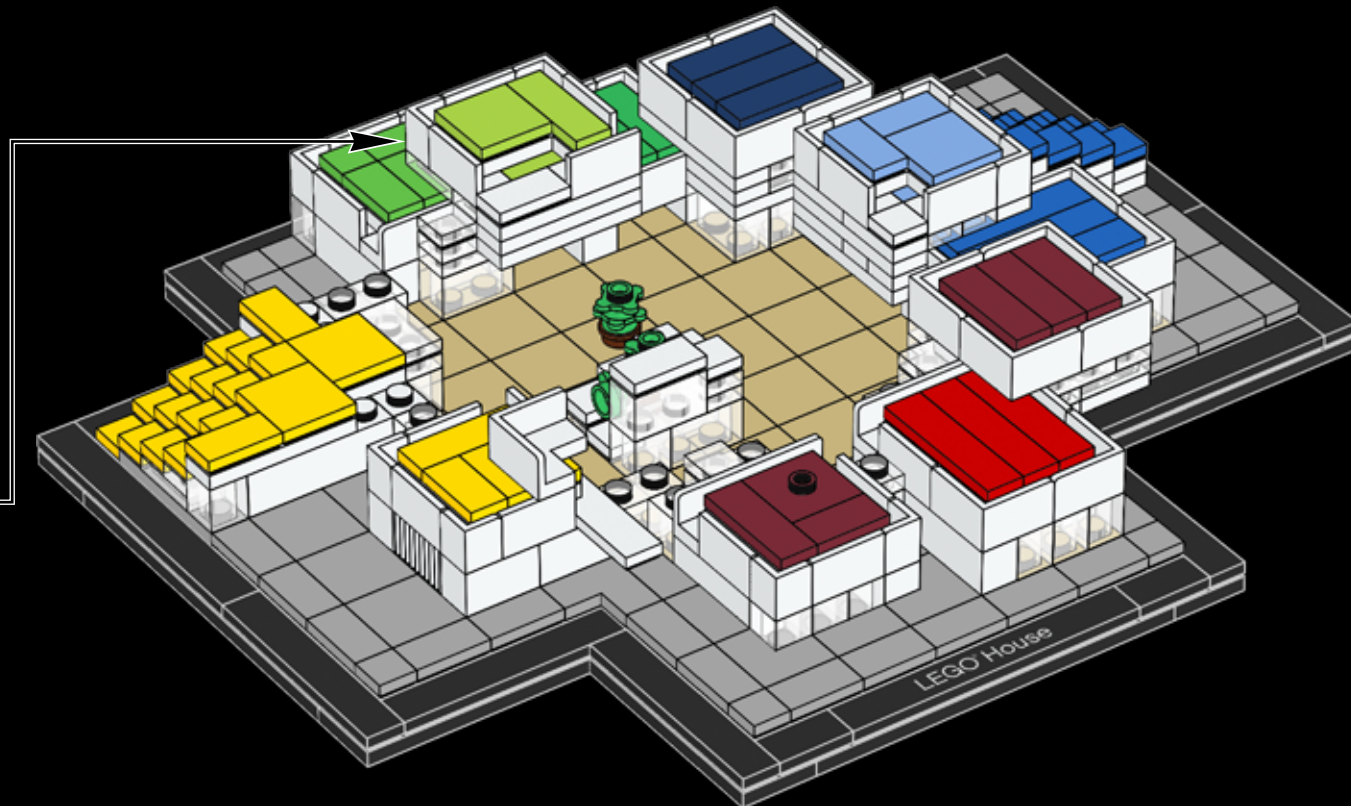



1x

115



1x



1x

116



1x

117

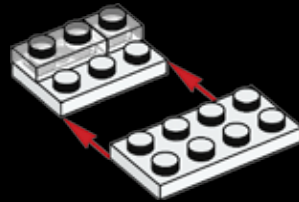

1x

118



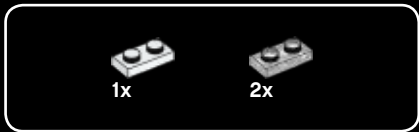

119

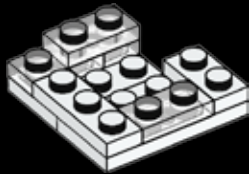

120

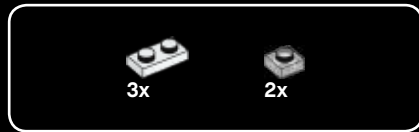
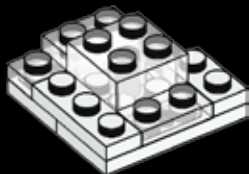

121





4x

122



3x



1x

123

1



2

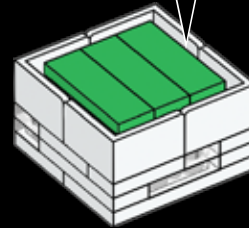

124

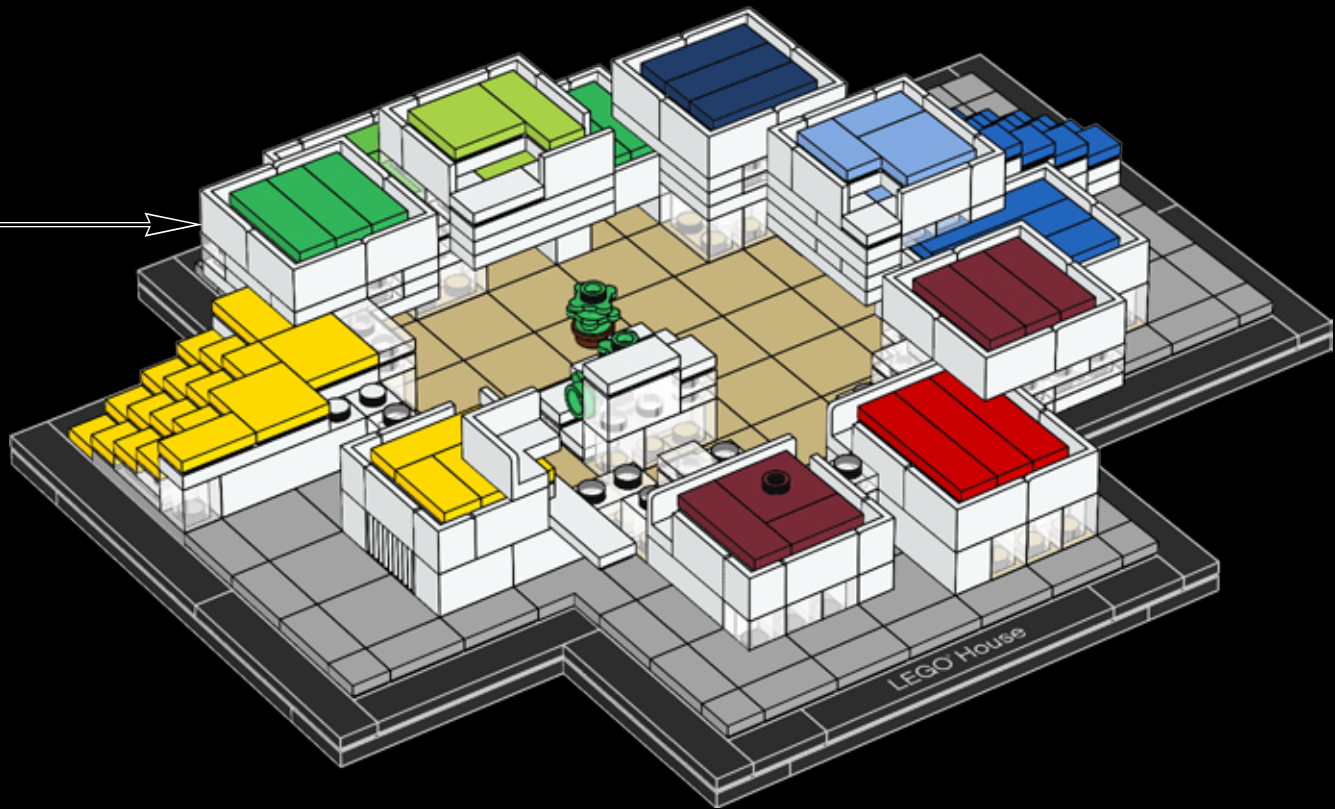



125

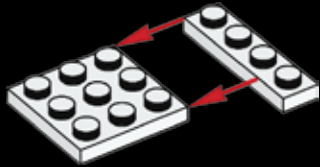

126

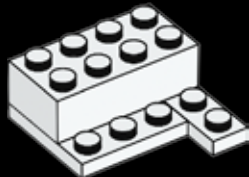

127

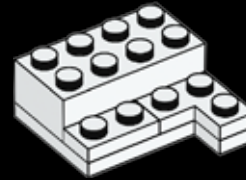

128

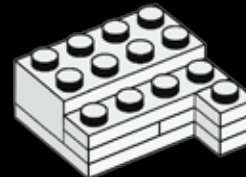



129

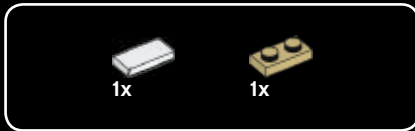
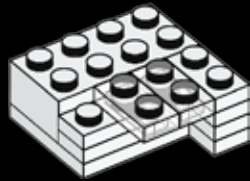

130

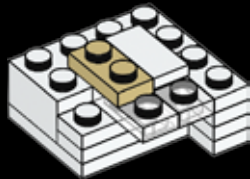

131

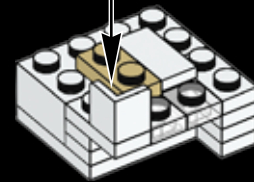
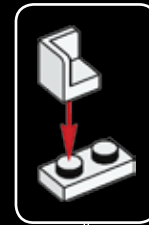



132

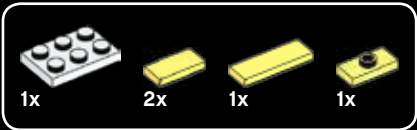
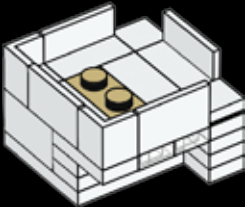

133

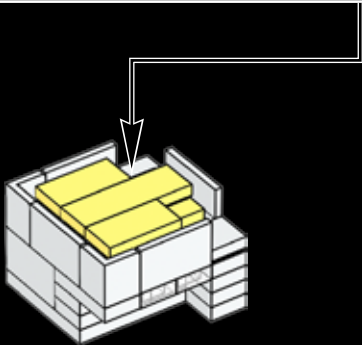
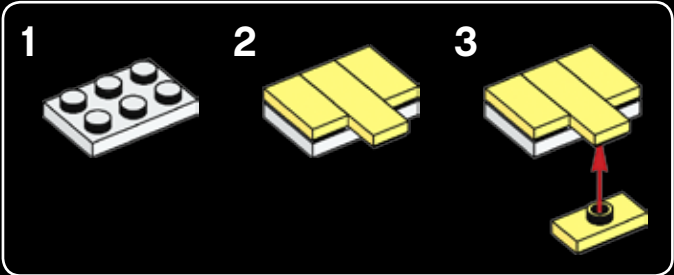

134

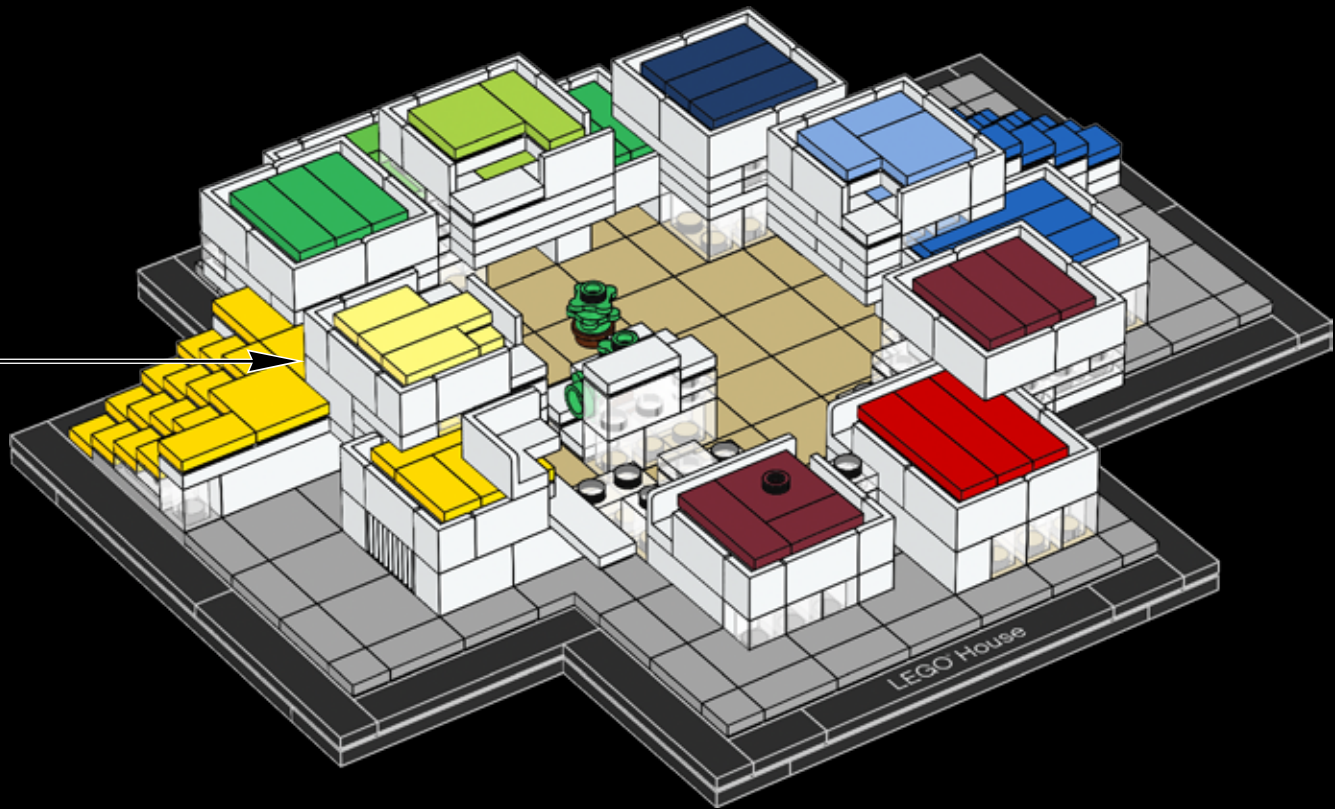



1x



1x

135

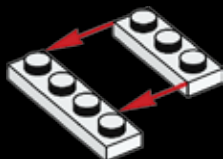

1x

136



1x

137



1x

138





139

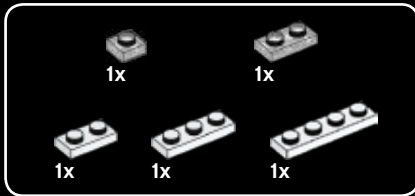

140

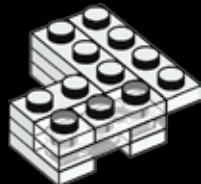

141





2x

142

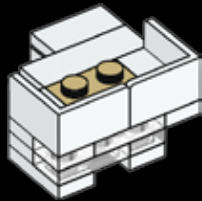

1x



1x



2x

143

1



2

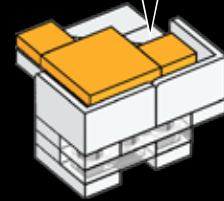

144

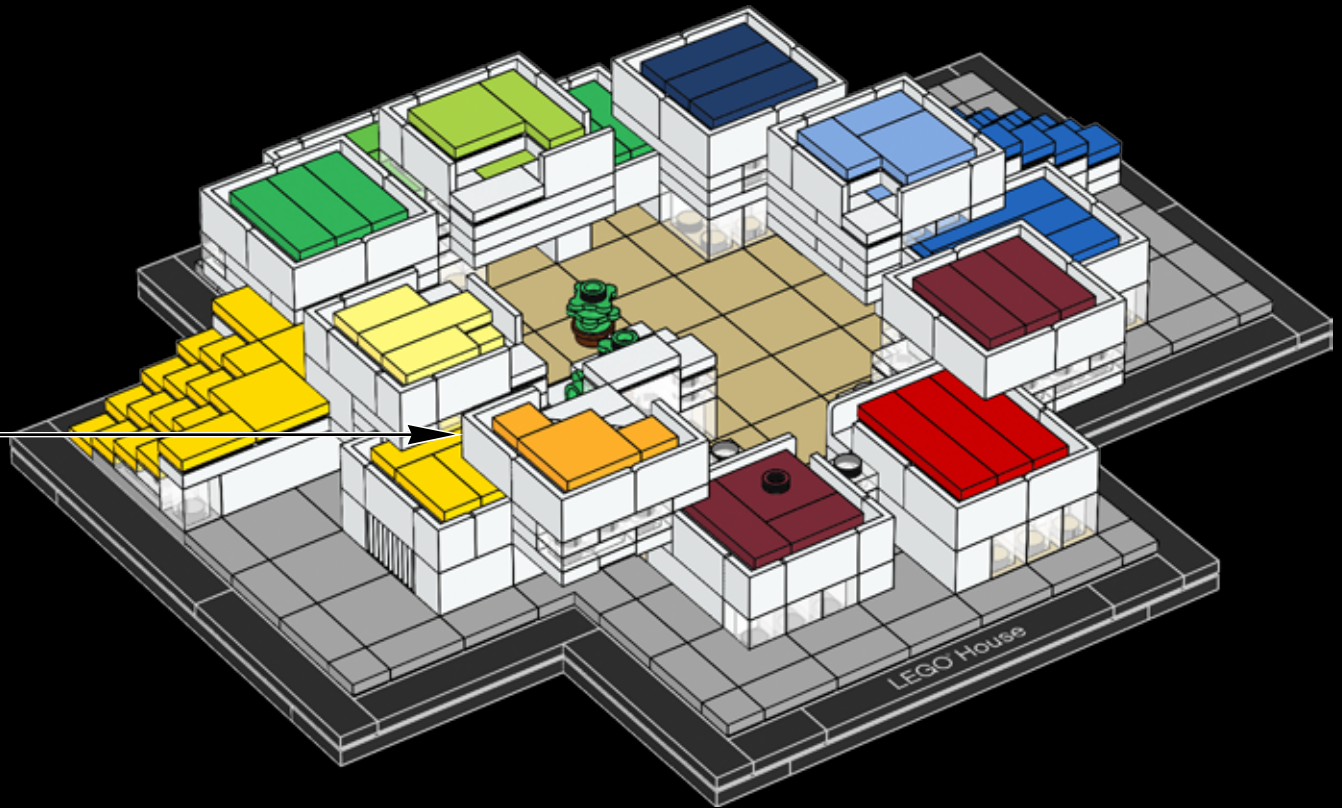



1x



1x

145

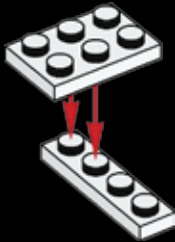

2x

146



1x



2x

147



1x



1x

148

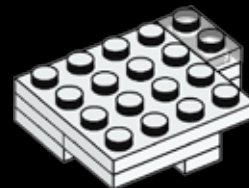



149

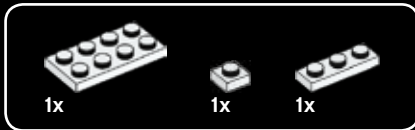
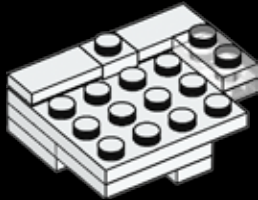
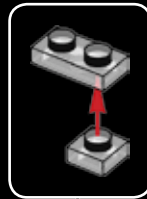

150

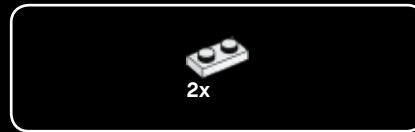
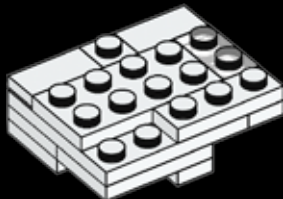
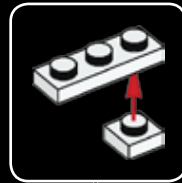

151

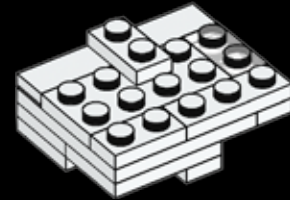

152

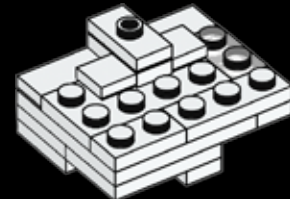

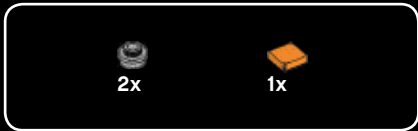

153

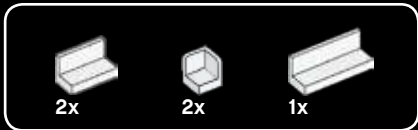
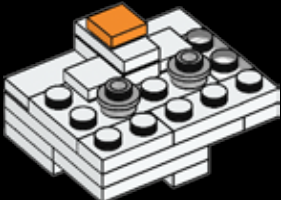

154

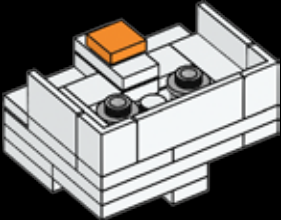

155

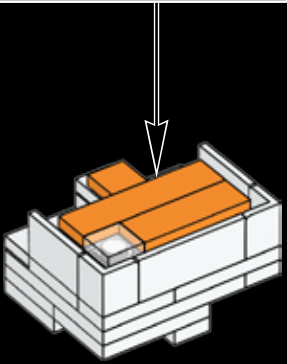
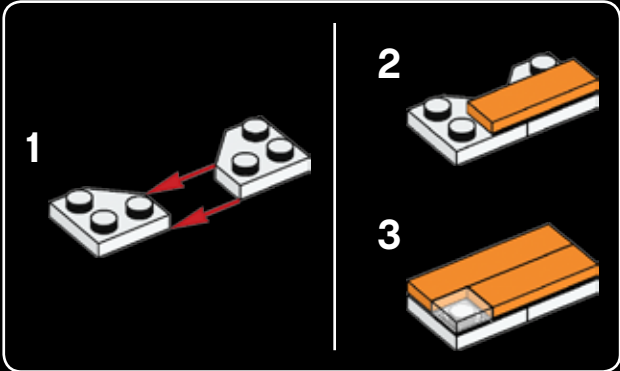

156

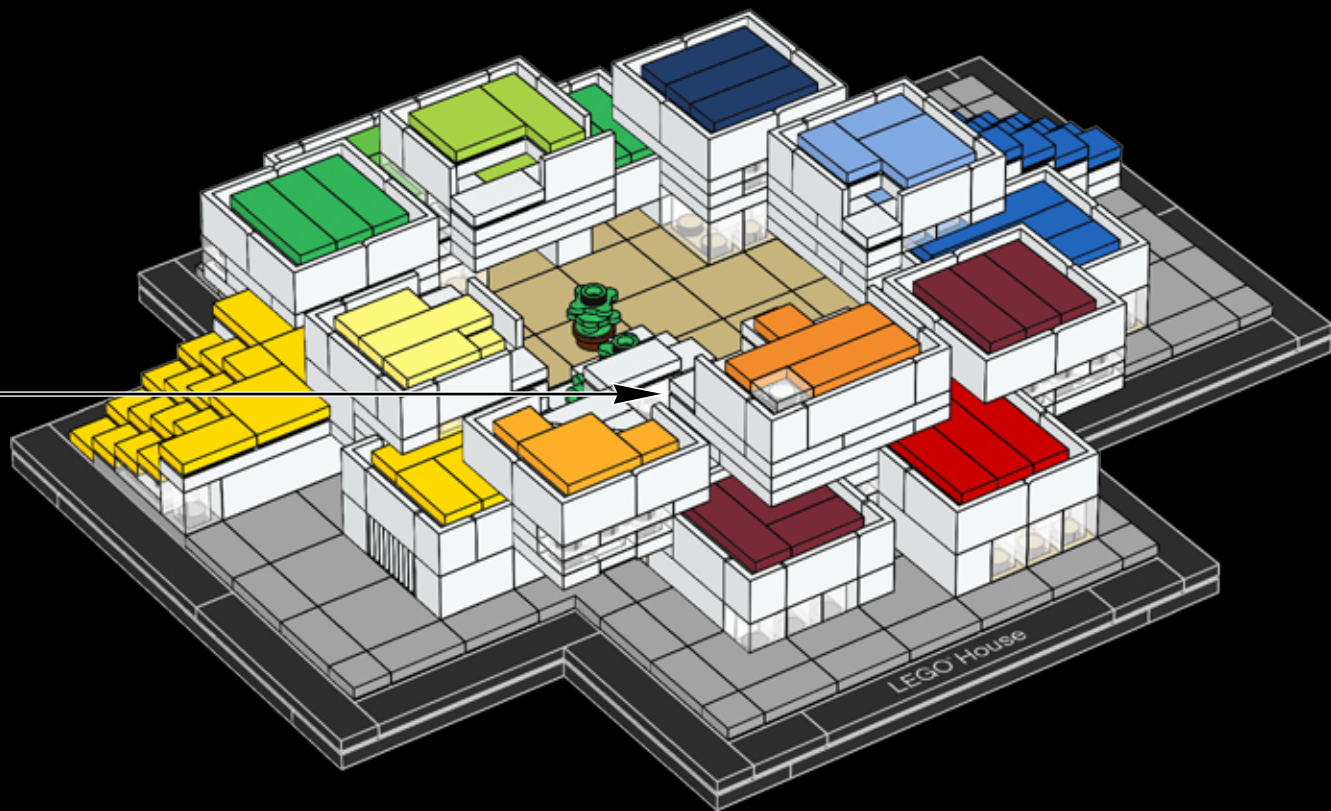

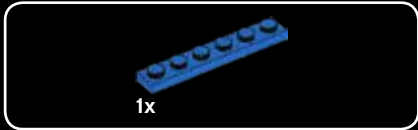
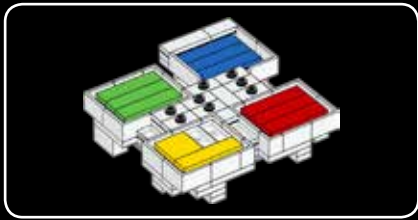

157

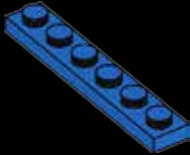

158

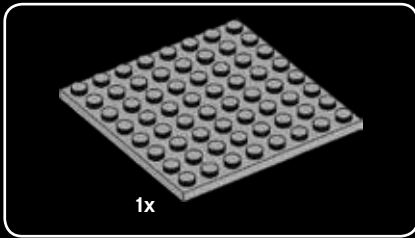

159

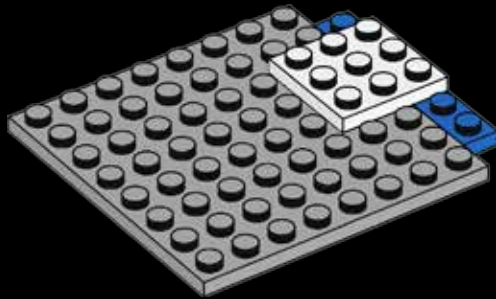



160

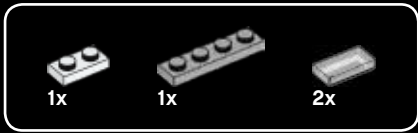
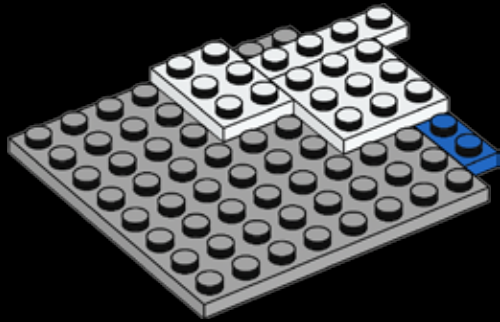

161

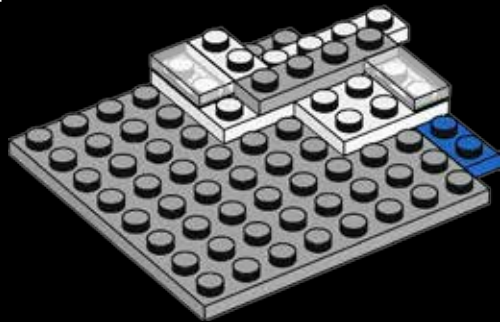

162

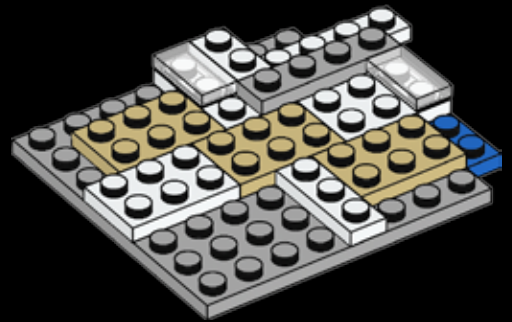



163

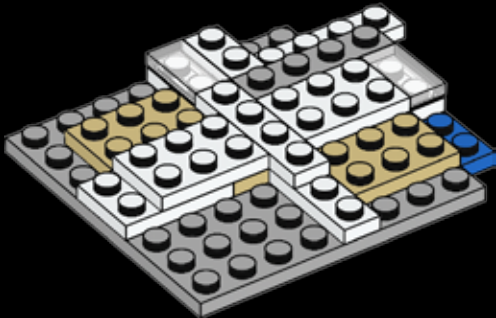

164

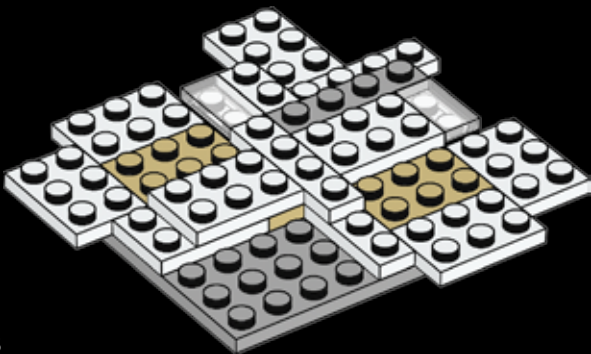

165

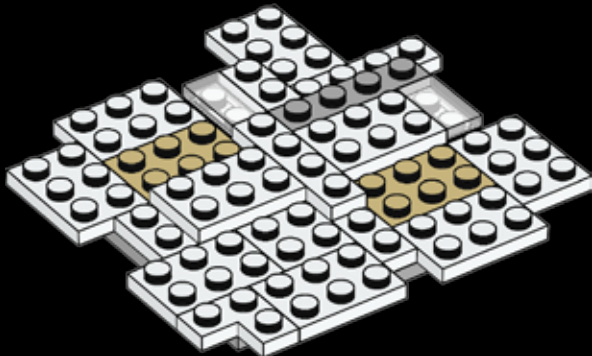

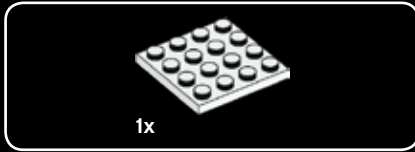

166



167

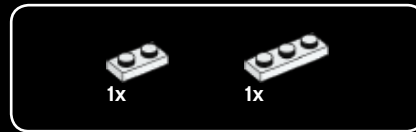

168

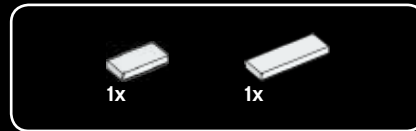
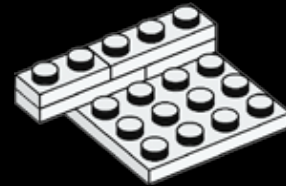

169



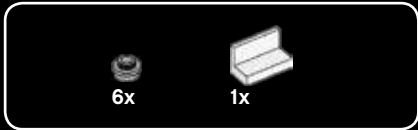

170



171

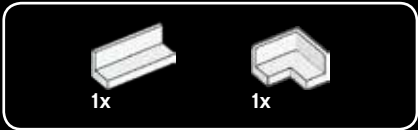
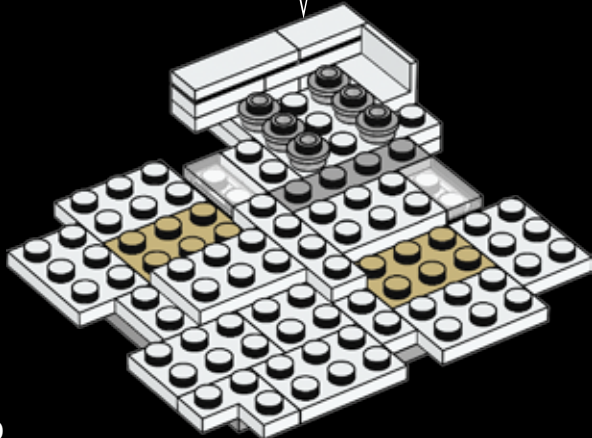

172

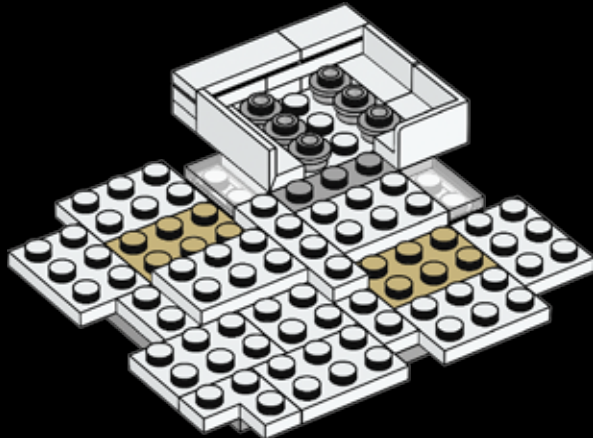



173

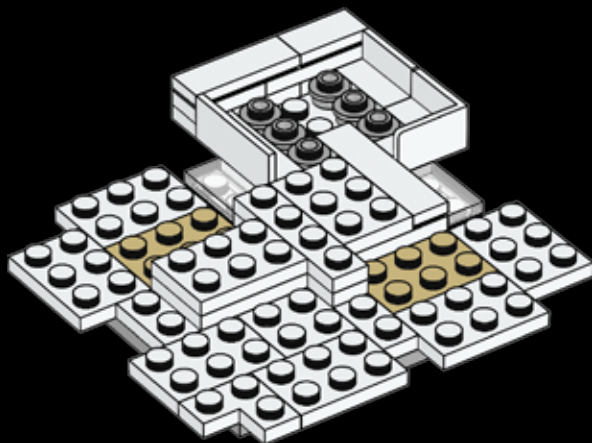

174

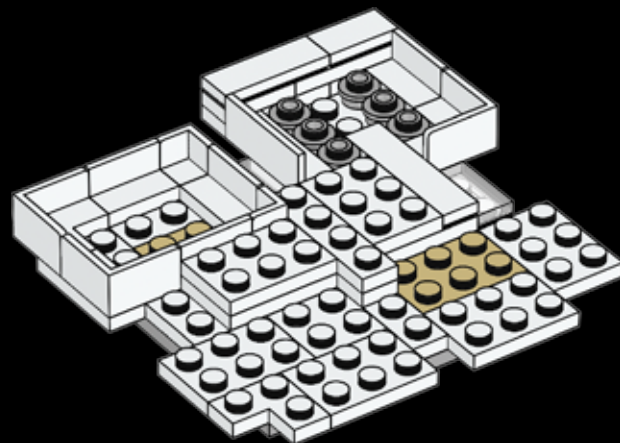



175

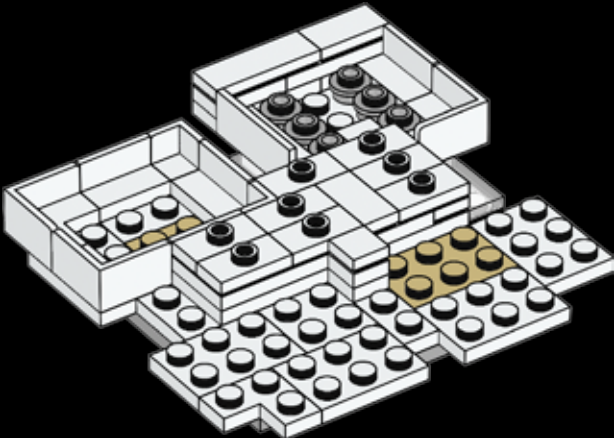

176

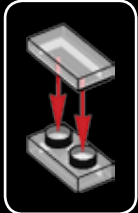
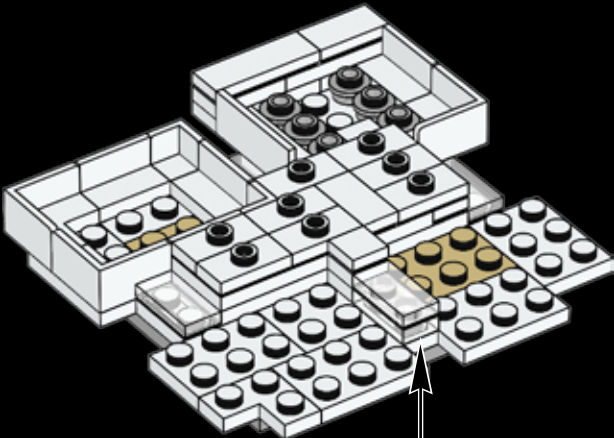



177

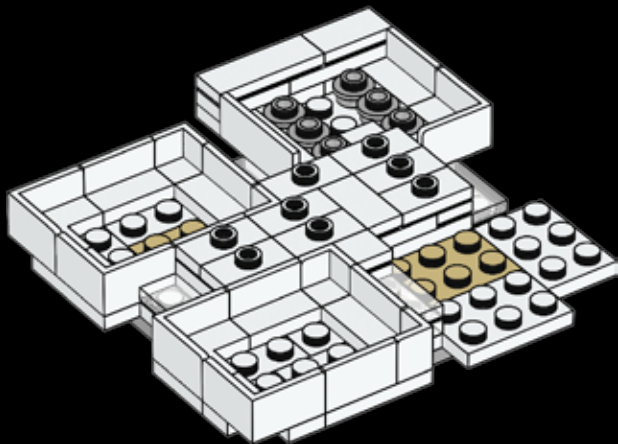

178

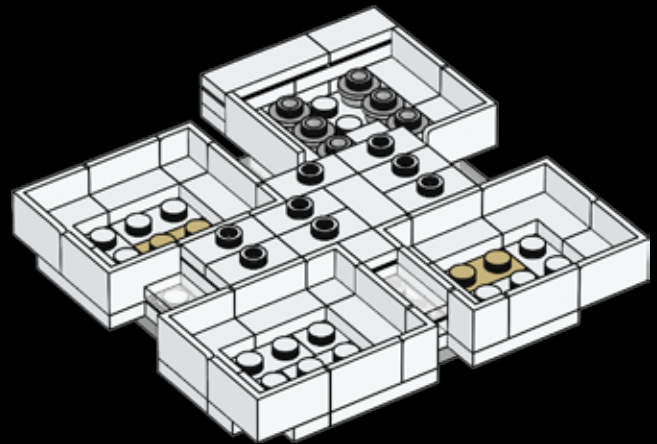



179

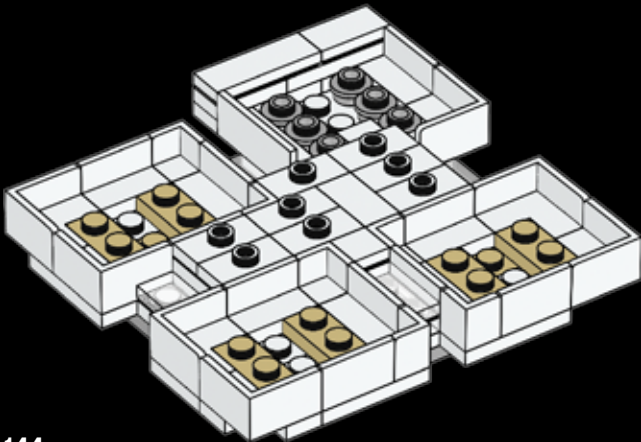

180

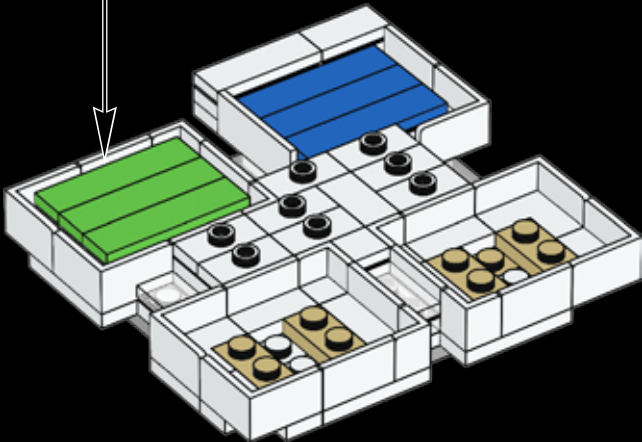
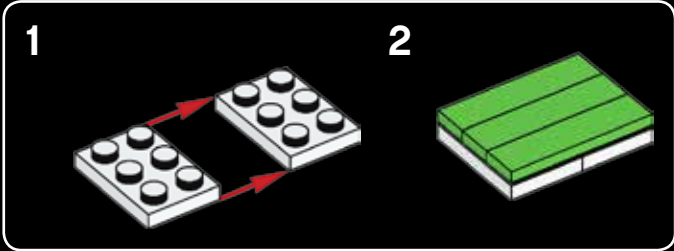

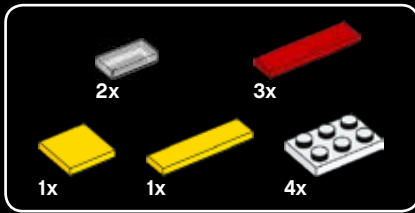

181

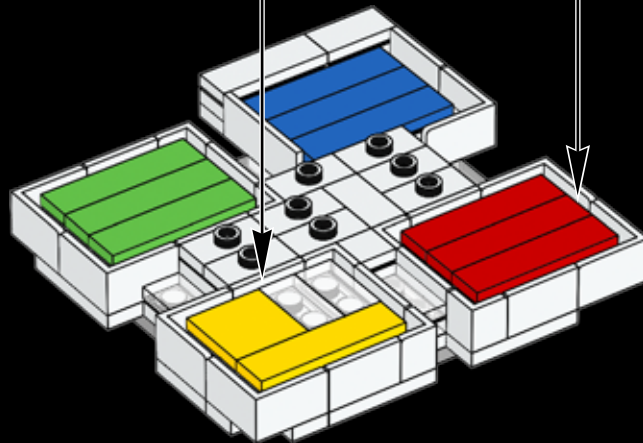
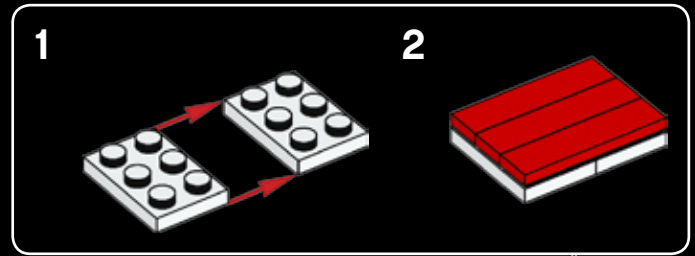
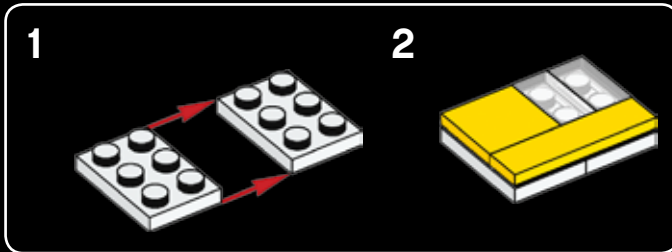



5x

182

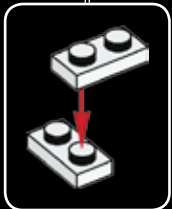
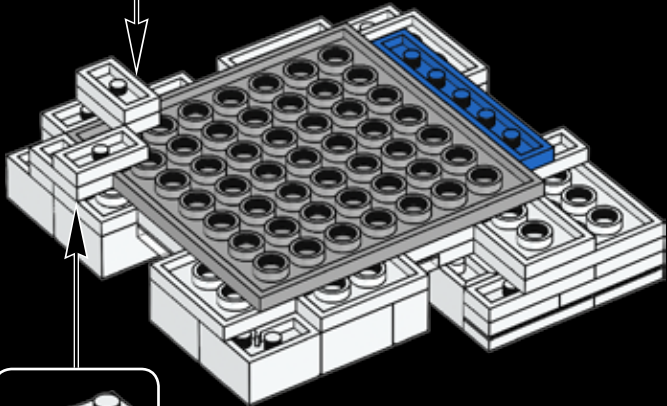
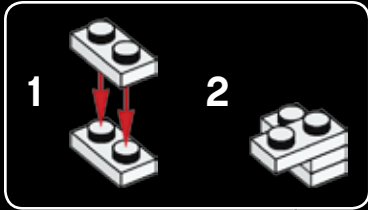

146



1x



1x



1x



1x

183

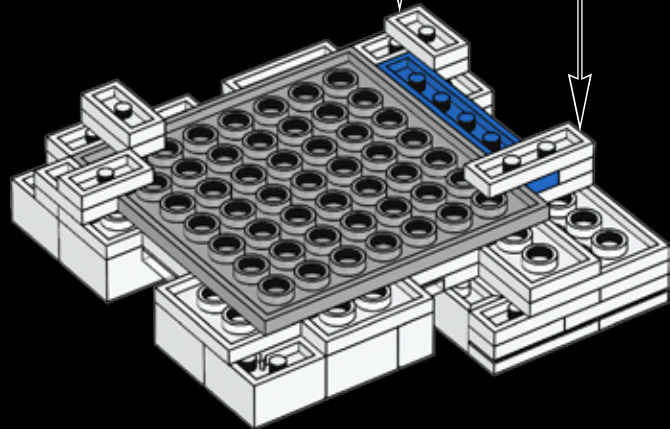
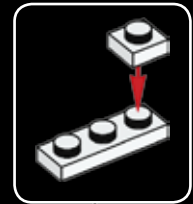
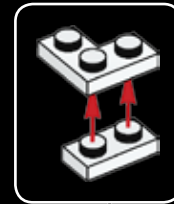



184

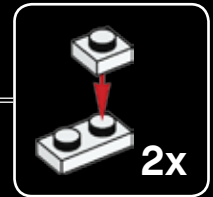
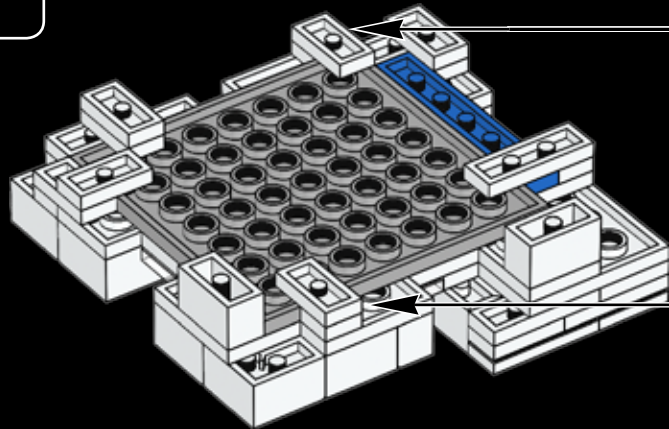

185

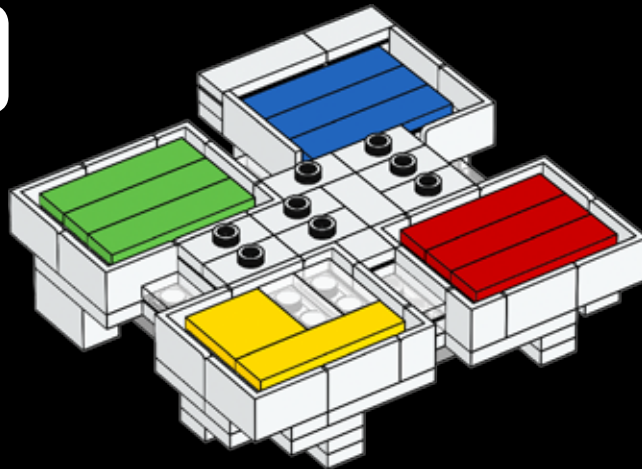
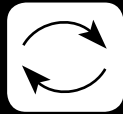

186

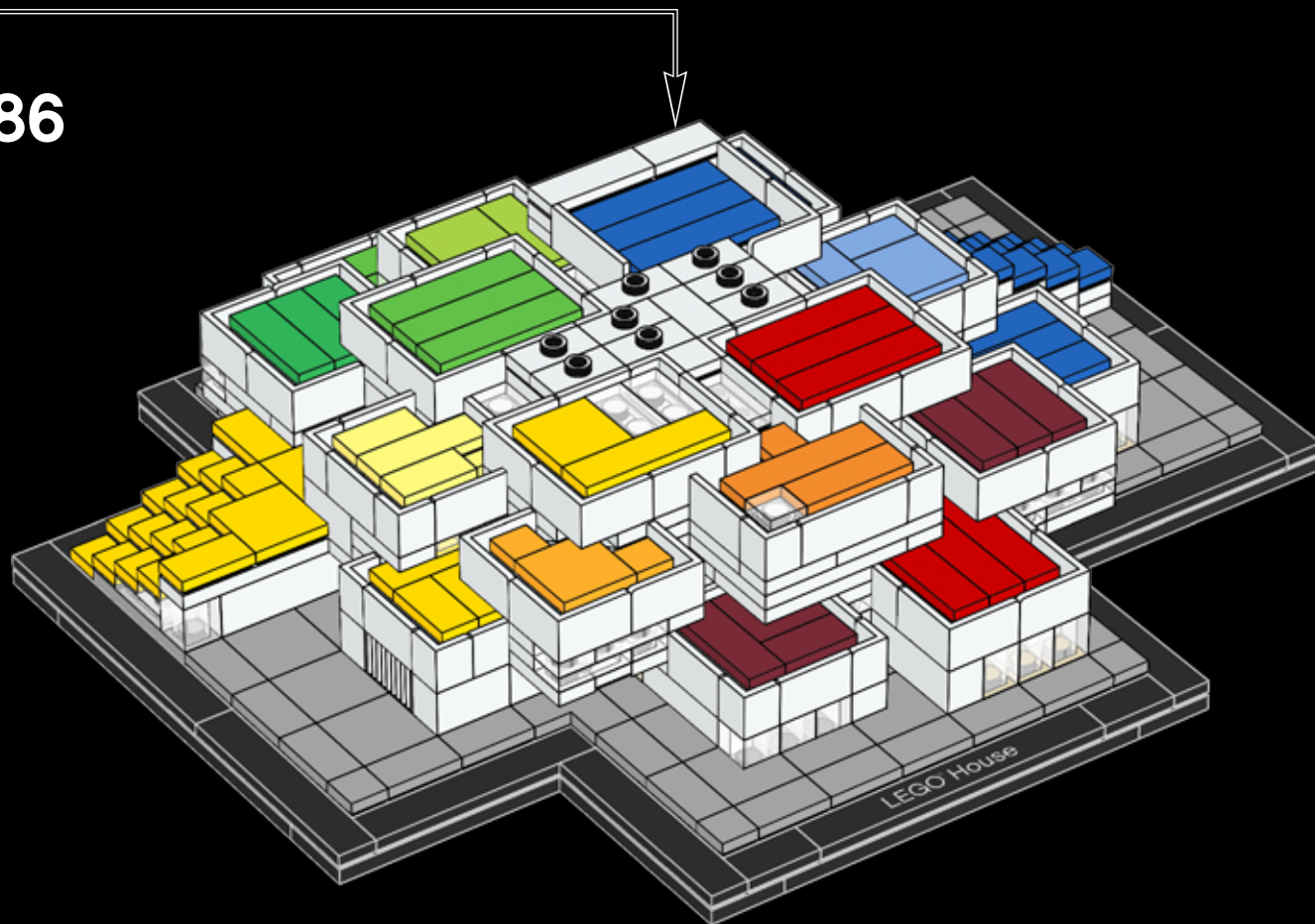

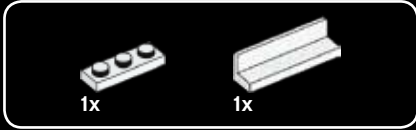

187

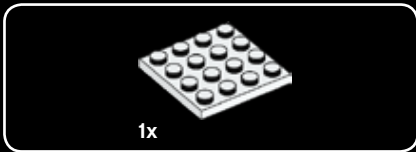
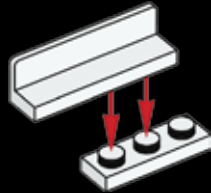

188



189



190





1x

191

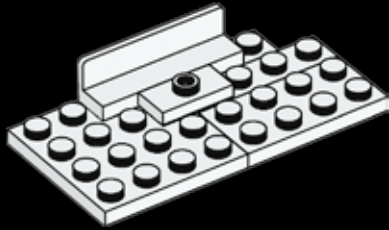

2x



1x

192

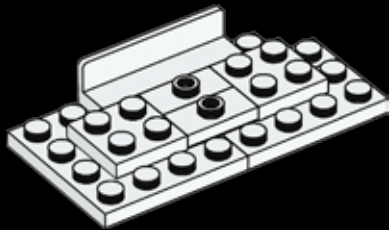

1x



4x

193

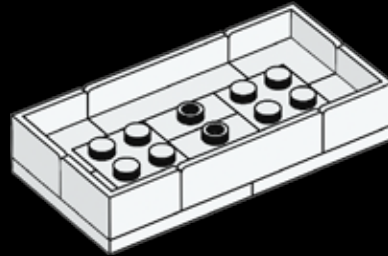

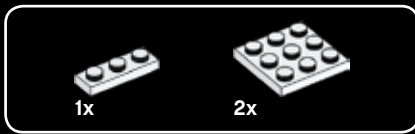

194

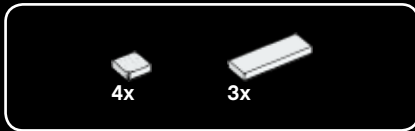
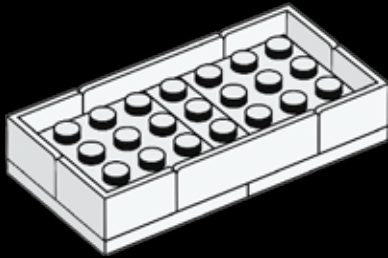

195

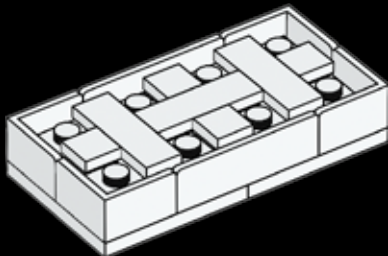

196

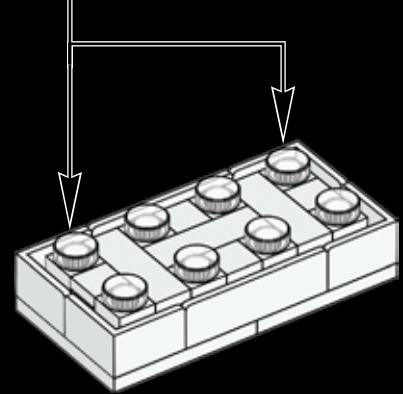
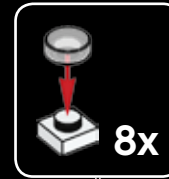

197

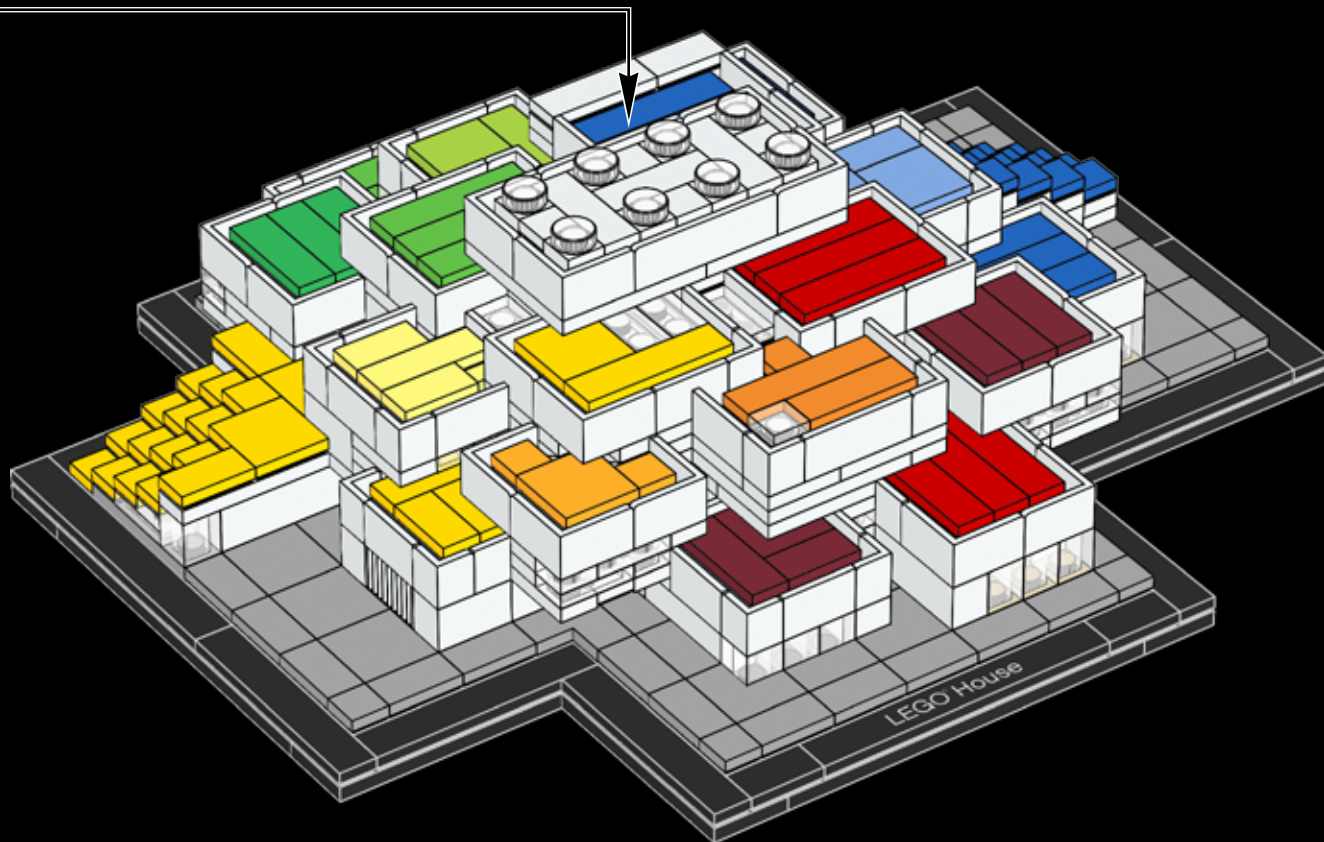



LEGO® Architecture – do you like it?

The LEGO Group would like your opinion on the new product you have just purchased. Your feedback will help shape the future development of this product series. Please visit:

[LEGO.com/productsurvey](https://www.lego.com/productsurvey)

By completing our short feedback survey, you will be automatically entered into a drawing to win a LEGO® prize.

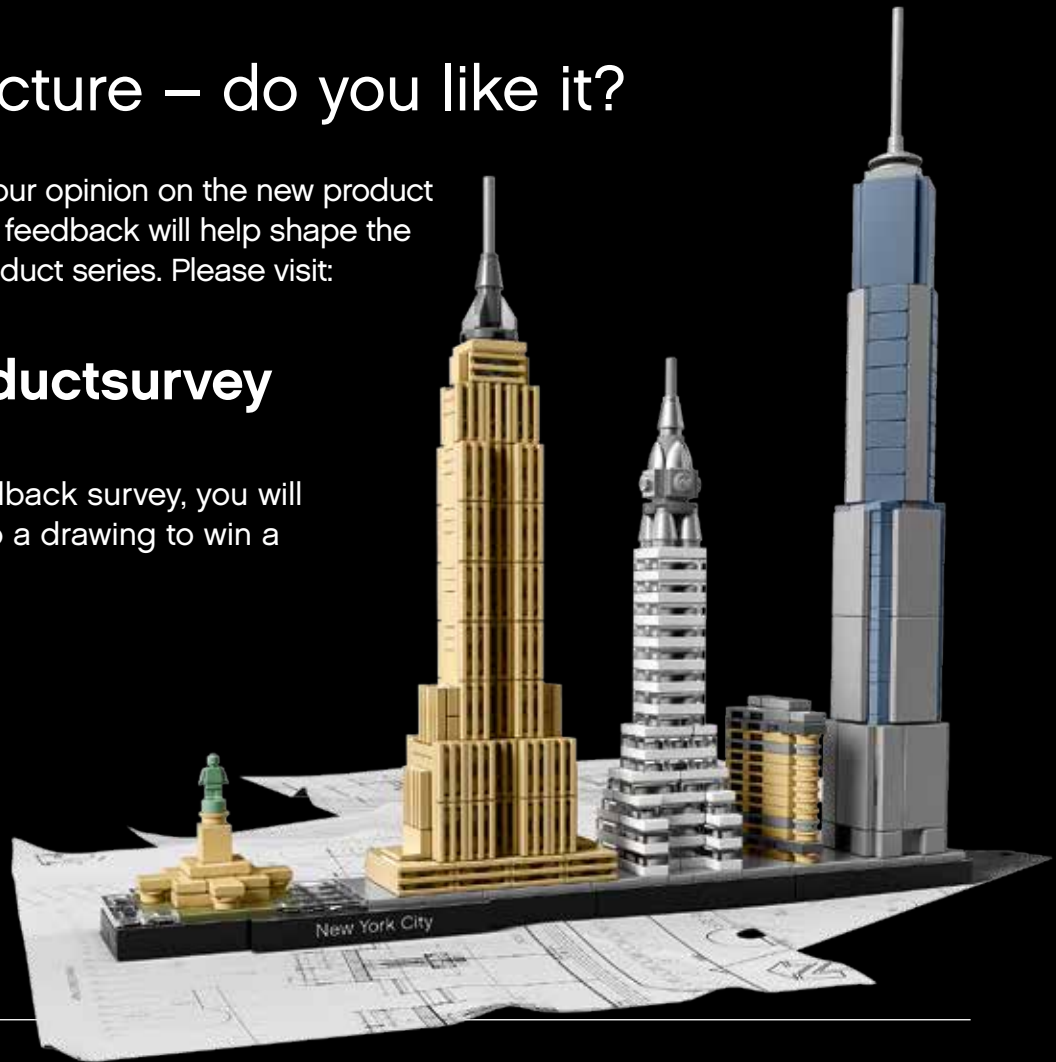

See website for official rules and details. Open to all countries where not prohibited.

LEGO and the LEGO logo are trademarks of the/son des marques de commerce du/son marcas registradas de LEGO Group.

©2017 The LEGO Group.

Aimez-vous LEGO® Architecture ?

Le Groupe LEGO aimerait connaître votre opinion sur le produit que vous venez d'acheter. Vos commentaires nous aideront à concevoir les futurs produits de cette gamme.

Rendez-vous sur :

[LEGO.com/productsurvey](https://www.lego.com/productsurvey)

En remplissant ce court sondage sur le produit, vous serez automatiquement inscrit à un tirage au sort pour gagner un prix LEGO®.

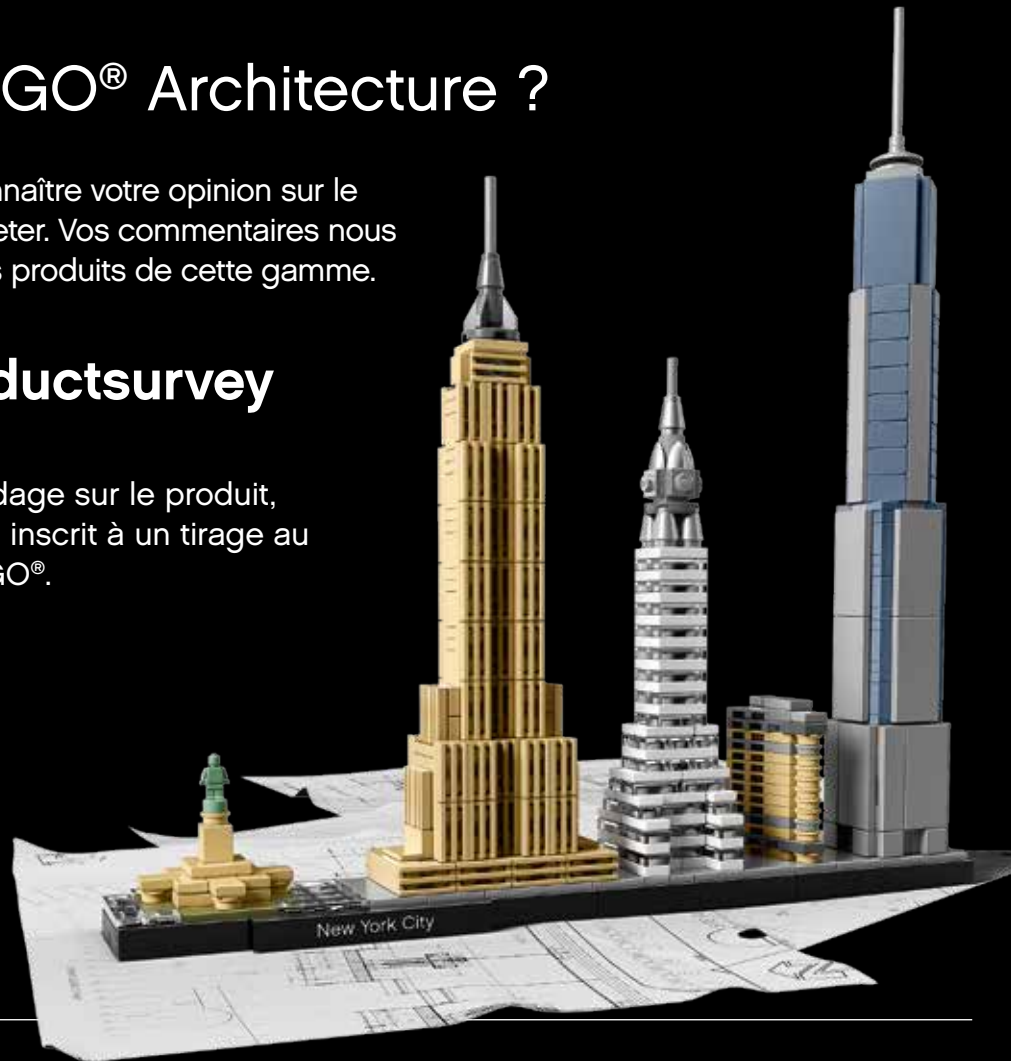

Consultez le site Web pour obtenir le règlement officiel et les détails. Ouvert à tous les résidents des pays autorisés.

LEGO and the LEGO logo are trademarks of the/son des marques de commerce du/son marcas registradas de LEGO Group.

©2017 The LEGO Group.

LEGO® Architecture: ¿te gusta?

The LEGO Group quiere conocer tu opinión acerca del nuevo producto que acabas de comprar. Tus comentarios nos ayudarán a dar forma a los futuros productos de esta serie. Visita:

[LEGO.com/productsurvey](https://www.lego.com/productsurvey)

Al rellenar esta breve encuesta de opinión, participarás automáticamente en el sorteo de un producto LEGO®.



Consulta las reglas oficiales y demás información en el sitio web. Válido en todos los países en los que esta actividad no esté prohibida.

LEGO and the LEGO logo are trademarks of the/son des marques de commerce du/son marcas registradas de LEGO Group.
©2017 The LEGO Group.

LEGO® Architecture—then and now

There has always been a natural connection between the LEGO® brick and the world of architecture. Fans who build with LEGO elements instinctively develop an interest in the form and function of the structures they create. At the same time, many architects have discovered that LEGO bricks are the perfect way of physically expressing their creative ideas.

This connection was confirmed in the early 1960s with the launch of the LEGO 'Scale Model' line. It matched the spirit of the age where modern architects were redefining how houses look and people were taking an active interest in the design of their new homes. These sets were designed to be different from the normal, brightly colored LEGO boxes; they also included a book on architecture as a source of inspiration.

Decades later, architect and LEGO fan Adam Reed Tucker, revived the idea of expressing architecture using LEGO bricks and in partnership with the LEGO Group, launched the LEGO Architecture line that we know today.

His first models, and the original sets in the current LEGO Architecture series, were interpretations of famous skyscrapers from his hometown of Chicago. Since then LEGO Architecture has developed and evolved, first with well-known buildings from other cities in the United States, and now with iconic structures from Europe, the Middle East and Asia.

The introduction of our LEGO Architecture Studio set echoes the ambitions of the earlier LEGO 'Scale Model' line and widens the potential of the LEGO Architecture series. Now you can enjoy building and learning about specific landmark buildings, or create exciting architectural models from your own fantasy. An inspiring 270-page book, featuring a number of renowned architects from around the world, guides you through the principles of architecture and encourages you in your own creative building.

LEGO® Architecture – Hier et aujourd'hui

Il y a toujours eu une connexion naturelle entre la brique LEGO® et le monde de l'architecture. Les fans qui construisent avec des éléments LEGO développent instinctivement un intérêt pour la forme et la fonction des structures qu'ils créent. De nombreux architectes ont quant à eux découvert que les briques LEGO sont la façon idéale de matérialiser leurs idées de création.

Cette connexion a été confirmée au début des années 1960 avec le lancement de la gamme « Maquettes à l'échelle » LEGO. Cette gamme correspondait à l'esprit de l'époque, alors que les architectes modernes redéfinissaient les maisons, et que les gens s'intéressaient activement à la conception de leur résidence. Ces ensembles originaux étaient conçus pour être différents des boîtes LEGO habituelles aux couleurs vives, et incluaient aussi « un livret d'architecture » comme source d'inspiration.

Quelques décennies plus tard, l'architecte et fan de LEGO Adam Reed Tucker a fait revivre l'idée d'exprimer l'architecture en utilisant des briques LEGO. En partenariat avec le Groupe LEGO, il lança la gamme LEGO Architecture que nous connaissons aujourd'hui.

Ses premiers modèles, et les ensembles originaux de la gamme LEGO Architecture actuelle, étaient des interprétations de célèbres gratte-ciel de sa ville natale de Chicago. La gamme LEGO Architecture a depuis évolué et s'est élargie, tout d'abord avec des bâtiments célèbres d'autres villes des États-Unis, puis avec de célèbres monuments d'Europe, du Moyen-Orient et d'Asie.

L'introduction de notre ensemble LEGO Architecture Studio fait écho aux ambitions de la précédente gamme « Maquettes à l'échelle » LEGO et accroît le potentiel de la gamme LEGO Architecture. Vous pouvez maintenant découvrir et construire des monuments célèbres ou créer de passionnants modèles architecturaux nés de votre imagination. Un livret d'inspiration de 270 pages, présentant plusieurs architectes célèbres du monde entier, vous guide parmi les principes de l'architecture et vous encourage dans votre propre construction créatrice.

LEGO® Architecture: entonces y ahora

Siempre ha existido una conexión natural entre el brick LEGO® y el mundo de la arquitectura. Los fans que construyen con elementos LEGO desarrollan instintivamente un interés por la forma y las funciones de las estructuras que crean. Al mismo tiempo, muchos arquitectos han descubierto que los bricks LEGO son una forma perfecta de expresar físicamente sus ideas creativas.

Esta relación se confirmó a principios de la década de 1960, con el lanzamiento de la línea «Scale Model» de LEGO. Encajaba bien con el espíritu de la época: un tiempo en el que los arquitectos modernos redefinían el aspecto de las casas y la gente se interesaba cada vez más por el diseño de su nuevo hogar. Los sets se diseñaron para que se diferenciaban de los normales, que se comercializaban en cajas de brillantes colores, e incluían un libro sobre la arquitectura que proporcionaba inspiración a sus usuarios.

Décadas más tarde, el arquitecto y fan de LEGO Adam Reed Tucker reavivó la idea de expresar la arquitectura usando bricks LEGO y, en colaboración con The LEGO Group, lanzó la línea LEGO Architecture que hoy conocemos.

Sus primeros modelos, y los sets originales de la actual serie LEGO Architecture, eran interpretaciones de los rascacielos más famosos de su ciudad natal, Chicago. Desde entonces, LEGO Architecture se ha desarrollado y ha evolucionado, primero incorporando edificios célebres de otras ciudades de Estados Unidos y, ahora, estructuras emblemáticas de Europa, Oriente Próximo y Asia.

La introducción del set LEGO Architecture Studio recupera las ambiciones de la antigua línea «Scale Model» de LEGO y amplía el potencial de la serie LEGO Architecture. Hoy puedes disfrutar mientras construyes y aprendes sobre edificios célebres, o crear tus propios modelos arquitectónicos a partir de tu imaginación. Un instructivo libro de 270 páginas con materiales creados por arquitectos internacionales de gran reputación te guiará a través de los principios de la arquitectura y te animará a dar tus primeros pasos en el mundo de la construcción creativa.

Celebrate the world of architecture and collect all the models
Célébrez le monde de l'architecture et collectionnez tous les modèles
Celebra el mundo de la arquitectura y colecciona todos los modelos

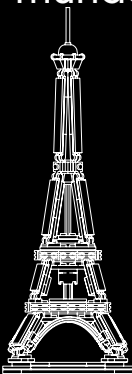

21019
The Eiffel Tower
La tour Eiffel
La Torre Eiffel

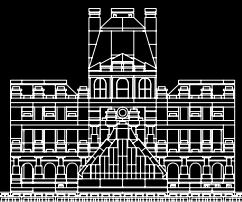

21024
Louvre

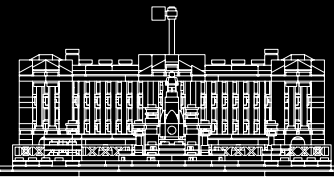

21029
Buckingham Palace
Le palais de Buckingham
Palacio de Buckingham

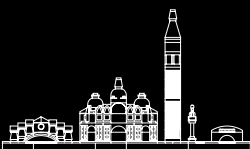

21026
Venice
Venise
Venecia



21027
Berlin
Berlín



21028
New York City
New York
Nueva York

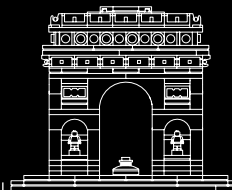

21036
Arc de Triomphe
L'Arc de Triomphe
Arco del Triunfo

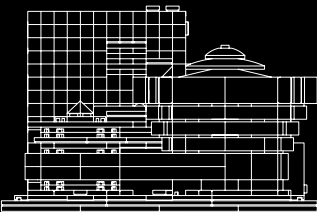

21035
Solomon R. Guggenheim Museum®
Musée Solomon R. Guggenheim®
Museo Solomon R. Guggenheim®



21030
United States Capitol Building
Le Capitole des États-Unis
Edificio del capitolio de Estados Unidos

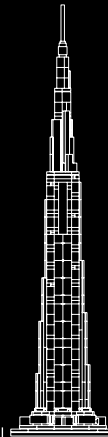

21031
Burj Khalifa



21032
Sydney
Sidney

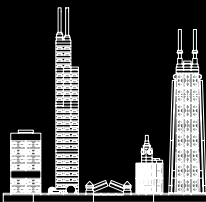

21033
Chicago

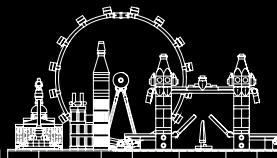

21034
London
Londres

References

Text credits:

LEGO® House

BIG – Bjarke Ingels Group

Photo credits:

LEGO House

BIG – Bjarke Ingels Group

For further information please visit:

LEGOHouse.com

Références

Crédits textes :

LEGO® House

BIG – Bjarke Ingels Group

Crédits photos :

LEGO House

BIG – Bjarke Ingels Group

Pour en savoir plus, veuillez vous rendre sur :

LEGOHouse.com

Referencias

Redacción:

LEGO® House

BIG: Bjarke Ingels Group

Fotografías:

LEGO House

BIG: Bjarke Ingels Group

Para más información, visita:

LEGOHouse.com

Customer Service
Kundenservice
Service Consommateurs
Servicio Al Consumidor
LEGO.com/service or dial



00800 5346 5555:



1-800-422-5346:





Customer Service

Kundenservice

Service Consommateurs

Servicio Al Consumidor

LEGO.com/service or dial



: 00800 5346 5555

: 1-800-422-5346

