



F · R · I · E · N · D · S

21319

THE TELEVISION SERIES
LA SÉRIE TÉLÉVISÉE
LA SERIE PARA TELEVISIÓN



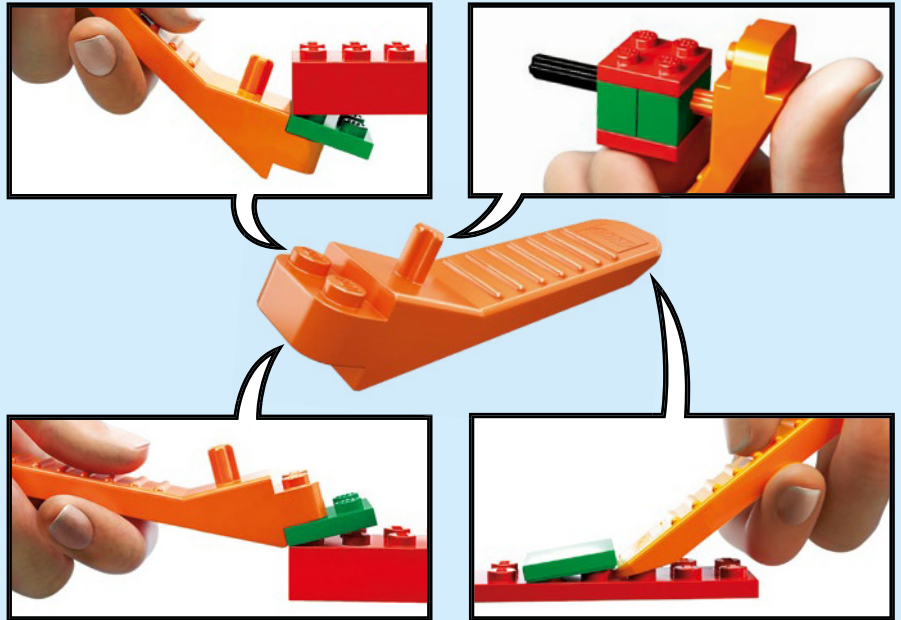

LEGO.com/brickseparator



- 1** Download the LEGO® Life App
 Lade dir die LEGO® Life App herunter
 Télécharge l'application LEGO® Life
 Télécharger l'application LEGO® Life
 Scarica l'app LEGO® Life
 Descarga la app LEGO® Life
 Descarrega a App LEGO® Life
 Töltsd le a LEGO® Life Appot!
 Lejupielādē lietotni LEGO® Life
 下载 LEGO® Life 应用程序



- 2** Scan the code on the front cover
 Scanne den Code auf der Titelseite
 Scanne le code sur la page de couverture
 Scanner le code sur la page couverture
 Scansiona il codice sulla copertina
 Escanea el código de la portada
 Faz scan do código na frente da capa
 Olvasd be a borítón látható kódot!
 Noskenē kodu uz priekšējā vāka
 扫描封面上的二维码

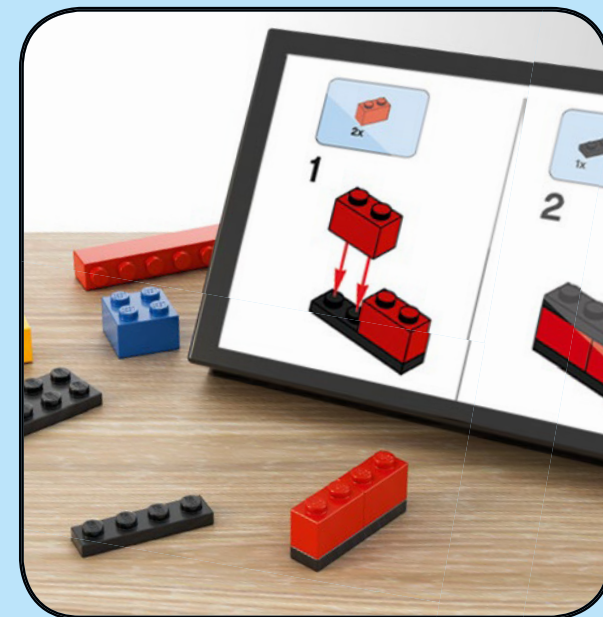

- 3** Get the Building Instructions
 Hol dir die Bauanleitung
 Obtens les instructions de montage
 Obtenir les instructions de montage
 Scarica le istruzioni per la costruzione
 Consulta las instrucciones de construcción
 Obtém as Instruções de Construção
 Szerezd be az építési útmutatókat!
 Saņem būvēšanas instrukcijas
 获取拼搭说明

LEGO.com/apps

Check for compatibility
 Kompatibilität prüfen
 Vérifier la compatibilité
 Controlla la compatibilità
 Comprueba tu compatibilidad

Verificar a compatibilidade
 Ellenőrizd a kompatibilitást
 Pārbaudīt saderību
 检查兼容性



For those who watched the show as it aired, it's hard to believe that Friends™ is now 25 years old. The American sitcom aired for ten seasons from 1994 to 2004, depicting the lives of six friends living in New York City who spend a lot of time hanging out in a coffee shop.

The show's premise is fresh, innocent and appealing, with plenty of mileage. There is escapist fun and gags aplenty as the comedic ensemble of Rachel, Ross, Joey, Chandler, Monica and Phoebe negotiates the twists and turns of adult life. But the show also handles relatable issues; love lives, jobs, family, success, failure, how to live your life and of course, friendships. It is comedy with a story and a heart, and easy for all kinds of audiences to connect with; the reason why the show's re-runs still have a great appeal for all generations.

This LEGO® Ideas set pays homage to the coffee shop, Central Perk, where the characters spent time together, but with the added layer of it being in its television studio set form. Created by Aymeric Fievet in collaboration with the LEGO Ideas team, we think it's a brilliant tribute to the phenomenon of Friends™. Enjoy the show!





Ross Geller

Dr. Ross Eustace Geller, Ph.D. is a paleontologist and Monica's brother. The most academic character of the show, Ross is also a sweet-natured and quirky guy, and a hopeless romantic. Ross has a child, Ben, from a former relationship and has a complicated but compelling on/off romance with Rachel throughout the series...were they on a break...or not?



Rachel Green

Rachel Karen Green is the spoiled but warm-hearted and likable daughter of a rich vascular surgeon and his wife. Rachel is introduced into the series in the first episode after she leaves her fiancé, Barry, at the altar, and attempts to live independently, working as a waitress. Rachel and Ross have some serious chemistry, and their on/off relationship is an overarching theme across the entire series.



Monica Geller

Monica E. Geller-Bing is the younger sister of Ross and best friend of Rachel, who she also rooms with. She works primarily as a chef at a variety of restaurants. Monica is described as the mother hen of the group and is known for her competitive nature. She later marries Chandler.



Joey Tribbiani

Joseph Francis "Joey" Tribbiani Jr. is a good-natured actor and food lover, who becomes mildly famous for his role as Dr. Drake Ramoray on the fictional hospital TV show 'Days of Our Lives'. Joey is Chandler's roommate for most of the show, and is popular with the ladies, known for his catchphrase/pick-up line "How you doin'?"



Chandler Bing

Chandler Muriel Bing is Joey's roommate and wingman, a sarcastic but sweet guy who quits his 'suit' job as an executive in a large multi-national corporation to become an intern and later junior copywriter at an advertising agency. Chandler and Monica become a thing...and later get married.



Phoebe Buffay

Phoebe Buffay is a ditzzy, sweet-natured masseuse who grew up homeless. She is an aspiring musician who plays the guitar and sings songs with somewhat unusual lyrics at the coffee shop.



My favorite LEGO element is "1x2 Masonry (98283)," which I discovered in The Big Bang Theory™ set. I find it essential in the realization of buildings, houses, castles and my Central Perk, of course.

MEET THE FAN DESIGNER

Aymeric Fievet lives in Normandy, France and has been working in the computer industry for a decade. An extreme cinephile, he is passionate about series, movies and cartoons as well as LEGO® products, of course.

"I've played with LEGO products from a very young age and collected many sets. My collection is still evolving and I am particularly interested in the Minifigures series.

One of the sets that stays in my heart is the "6991 - Monorail Transport Base." I have very good childhood memories of this set, because it combined my two favorite activities: the circuit and space.



I oriented my project around one of my favorite series: Friends™. The challenge was to visualize passages of the series to allow me to recreate the furniture and the characters in as much detail as possible,

The assembly of this model took me about a week after finding the necessary references. During the voting period, the set was changed several times.

I can't explain my feelings when I reached the 10,000 votes, it was a mixture of joy and pride.



For a successful LEGO® Ideas project, you have to believe in yourself, be patient and don't hesitate to ask for help in case of difficulties, because there are many qualified and helpful people.

What I like about LEGO Ideas is that it gives you the opportunity to really use your imagination and if successful, see your name associated with your favorite brand! Moreover, it is playful and easy to use. It's always a pleasure to discover new creations every day.

My advice for those submitting ideas is ... know that your dream is possible! And take care of how your photos look because they are your best advert."

MEET THE LEGO® DESIGNERS

Milan Madge: Designer

Crystal Bam Fontan: Graphic Designer

What was your reaction when you were asked to work on this project?

Milan: When I was younger my time was carefully divided between two tasks, playing with LEGO® bricks and watching Friends™ – so this could not be more exciting!

Crystal: I'm a bit of a hardcore Friends™ fan, so when it was confirmed that this project was going through, I became a total Janice and was like "OH...MY...GOD!"



Crystal and Milan enjoy a coffee on the Central Perk set.

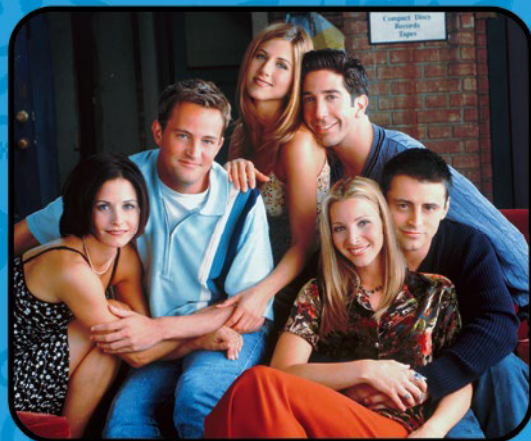

How does it differ from your other LEGO projects?

Milan: I was a LEGO fan for years and I know that the thought of contributing to an official LEGO product would have been a dream for me. To be a part of making that dream a reality for fans like Aymeric is what this job is all about.

Crystal: Working with LEGO Ideas is a bit more personal since we want to make the fan we are working with, and the fan community in general, proud of the finished products we achieve!

Why is a professional LEGO® designer a part of this process? What is your role?

Milan: My role in this project was to force as many Friends™ references into the design team's vocabulary as possible! Actually, the LEGO designer's role is to take the fan designer's concept and run it through our rigorous quality process in order to deliver the amazing building experience our fans have come to expect from an official LEGO product. It requires a certain level of unagi.

Crystal: As the Graphic Designer it was my job to turn the iconic cast of Friends™ into minifigures as well as design decorations to give the set that extra "Wah-Pah!" Each LEGO Ideas set needs a Design Team behind it, so that we can not only make sure that the end result is safe but also the best product we can achieve.

What impressed you the most about the original model?

Milan: Aymeric's model captured all the great little details found in the Central Perk café, and I mean all! The only things missing were some weird angles. As a television set, the walls of Central Perk are angled so that the cameras can capture more, resulting in a really interesting room layout. After visiting the Central Perk set in LA, I thought it would be a great opportunity to try this in LEGO form and decided to make the wall "pivot!"

Crystal: I was also very impressed by how thorough Aymeric's submission was! I loved the different versions of the minifigures he presented and the amount of detail he added in his model layout.



What part of the model are you most satisfied with?

Milan: Central Perk is a unique location and we really wanted to try something special for the 25th anniversary of Friends™. We included a few unexpected techniques for LEGO fans, while managing to capture a lot of the great references for Friends™ fans.

Crystal: My favorite part is the feature that allows you to remove the couch area from the model and lets you display it with the minifigures anywhere you would like! Milan and I also tried to add as many Easter eggs as we could possibly get into the set! We were very happy to include the "Reserved" sign, which is an Easter egg of an Easter egg of the show!



Ceux qui ont regardé *Friends*™ pour la première fois à la télévision ont peine à croire que la série a déjà 25 ans. Diffusée pendant dix saisons, de 1994 à 2004, cette comédie américaine raconte la vie quotidienne de six amis qui vivent à New York et qui passent beaucoup de temps à flâner dans un café.

La prémisse de la série est rafraîchissante, naïve et attrayante, et elle perdure dans le temps. Truffée de blagues et très divertissante, elle raconte les péripéties de la vie adulte de la troupe comique composé de Rachel, Ross, Joey, Chandler, Monica et Phoebe. Mais des sujets qui touchent tout le monde sont également abordés, comme la vie amoureuse, le travail, la famille, les succès et les échecs, comment vivre sa vie, et bien sûr, l'amitié. Il s'agit d'une comédie qui raconte une histoire attachante et qui met en vedette des personnages auxquels tous les types de spectateurs peuvent s'identifier. C'est d'ailleurs pourquoi les rediffusions de la série exercent encore un fort attrait auprès de toutes les générations.

Cet ensemble LEGO® Ideas rend hommage au Central Perk, le café où les personnages passaient du temps ensemble, et en plus, il est présenté sous la forme du studio de télévision. Créé par Aymeric Fievet, en collaboration avec l'équipe de LEGO Ideas, il constitue, à notre avis, un superbe hommage au phénomène *Friends*™. Bonne émission !





Ross Geller

Le Dr Ross Eustace Geller, Ph. D., est un paléontologue, et c'est aussi le frère de Monica. Même s'il s'agit du personnage le plus sérieux de la série, Ross est également doux et excentrique ainsi qu'un éternel romantique. Il a un enfant qui s'appelle Ben d'une ancienne relation et vit avec Rachel une histoire d'amour houleuse et compliquée, mais passionnante, tout au long de la série... Ont-ils rompu, ou non ?



Rachel Green

Rachel Karen Green est la fille gâtée d'un riche chirurgien vasculaire et de sa femme, mais elle est d'un naturel chaleureux et sympathique. Rachel fait son apparition lors du premier épisode de la série, après avoir quitté son fiancé, Barry, au beau milieu de leur mariage. Elle tente de vivre de façon autonome en travaillant comme serveuse. Rachel et Ross ont une forte attirance l'un envers l'autre, et leur relation ponctuée de ruptures et de réconciliations est un thème central tout au long de la série.



Monica Geller

Monica E. Geller-Bing est la sœur cadette de Ross et la meilleure amie de Rachel, avec qui elle partage un appartement. Elle travaille principalement comme chef dans plusieurs restaurants. Monica est décrite comme étant la mère poule du groupe, et elle est connue pour sa nature très compétitive. Plus tard, elle épouse Chandler.



Joey Tribbiani

Joseph Francis « Joey » Tribbiani Jr. est un acteur qui a un bon caractère et est très gourmand. Il devient quelque peu célèbre pour son rôle du Dr Drake Ramoray dans l'émission de télévision fictive *Les jours de notre vie*, qui se passe dans un hôpital. Joey est le colocataire de Chandler durant la majeure partie de la série. Il est populaire auprès des dames et connu pour sa célèbre phrase culte pour draguer : « Salut, ça va ? ».



Chandler Bing

Chandler Muriel Bing est le colocataire et compagnon de drague de Joey. Sarcastique, mais gentil, il quitte son travail en tant que directeur dans une grande multinationale pour devenir stagiaire et, plus tard, concepteur-rédacteur débutant dans une agence de publicité. Chandler et Monica nouent une relation... et finissent par se marier.



Phoebe Buffay

Phoebe Buffay est une masseuse charmante et naïve qui a grandi dans la rue. Elle souhaite devenir musicienne, et elle joue de la guitare et chante des chansons aux paroles plutôt particulières dans le café.



RENCONTRE AVEC LE FAN CONCEPTEUR

Aymeric Fievet vit en Normandie, en France, et travaille dans le secteur de l'informatique depuis dix ans. Cinéphile mordu, il est passionné par les séries, les films, les dessins animés, et bien sûr, les produits LEGO®.

« J'ai joué avec des produits LEGO dès mon plus jeune âge et collectionné de nombreux ensembles. Ma collection continue de s'agrandir, et je m'intéresse particulièrement aux séries de figurines.

L'un des ensembles que j'affectionne le plus est la base de transport monorail (6991). J'ai de très bons souvenirs d'enfance de cet ensemble, car il combinait mes deux champs d'intérêt favoris : le circuit et l'espace.

Ma pièce LEGO préférée est la brique de maçonnerie 1x2 (98283), que j'ai découverte dans l'ensemble *The Big Bang Theory*™. Je crois qu'elle est essentielle dans la construction des édifices, des maisons, des châteaux, et bien sûr, de mon Central Perk.



Mon projet est axé sur une de mes séries préférées : *Friends*™. Mon défi consistait à visionner des extraits de la série pour arriver à recréer les meubles et les personnages avec autant de détails que possible.

Il m'a fallu environ une semaine pour assembler ce modèle, après avoir trouvé les références nécessaires. Pendant la période de vote, l'ensemble a subi plusieurs modifications.

Il est difficile pour moi d'expliquer ce que j'ai ressenti lorsque j'ai atteint les 10 000 votes. C'était une émotion mêlée de joie et de fierté.



Pour réussir un projet LEGO® Ideas, vous devez croire en vous-même, être patient et ne pas hésiter à demander de l'aide en cas de difficulté, car il y a de nombreuses personnes qualifiées et serviables.

Ce que j'aime des projets LEGO Ideas, c'est qu'ils vous donnent l'occasion de réellement faire preuve d'imagination, et si vous réussissez, votre nom est associé à votre marque préférée ! De plus, les ensembles sont ludiques et faciles à utiliser. C'est toujours un plaisir de découvrir de nouvelles créations chaque jour.

Mon conseil aux personnes qui soumettent des idées est le suivant : dites-vous que votre rêve est réalisable ! Et portez attention à l'apparence de vos photos, car elles constituent votre meilleure publicité. »

RENCONTRE AVEC LES CONCEPTEURS LEGO®

Milan Madge : concepteur
Crystal Bam Fontan : graphiste

Quelle a été votre réaction lorsqu'on vous a demandé de travailler sur ce projet ?

Milan : Quand j'étais plus jeune, mon temps était soigneusement partagé entre deux activités : jouer avec des briques LEGO® et regarder *Friends*™. Alors, je n'aurais pas pu demander mieux comme projet passionnant !

Crystal : Comme je suis une fan pure et dure de *Friends*™, quand ce projet a été approuvé, je suis devenue une véritable Janice et je me suis exclamée : « OH... MON... DIEU ! »



Crystal et Milan prennent un café sur le plateau de tournage du Central Perk.

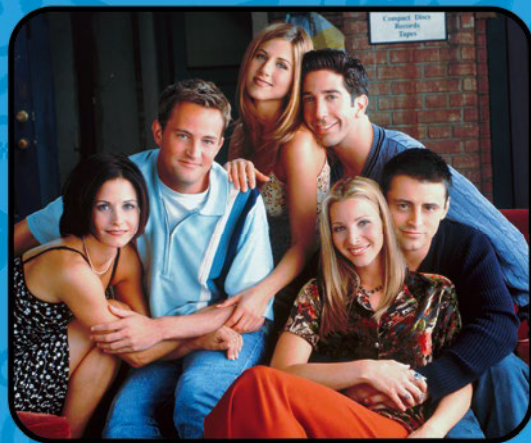

En quoi ce projet diffère-t-il de vos autres projets LEGO ?

Milan : J'ai été un fan de LEGO pendant des années, donc participer à la création d'un produit LEGO officiel aurait été un rêve pour moi. Et ce travail consiste justement à contribuer à la réalisation de ce rêve pour des fans comme Aymeric.

Crystal : Les projets LEGO Ideas nous touchent un peu plus personnellement, car nous voulons que les fans avec lesquels nous travaillons et les fans en général soient fiers des produits que nous réussissons à créer !

Pourquoi un concepteur LEGO® professionnel fait-il partie de ce processus ? En quoi consiste votre rôle ?

Milan : Mon rôle dans le cadre de ce projet était d'intégrer le plus de références de *Friends*™ possible dans le vocabulaire des membres de l'équipe de conception ! En fait, le rôle du concepteur LEGO consiste à utiliser le concept d'un fan concepteur et à le mettre au point en le soumettant à notre processus de qualité rigoureux, dans le but d'offrir l'expérience de construction formidable à laquelle nos fans s'attendent d'un produit LEGO officiel. Cela nécessite un certain niveau d'« unagi ».

Crystal : En tant que graphiste, mon travail consistait à transformer les acteurs emblématiques de *Friends*™ en figurines et à créer des décorations pour donner à l'ensemble un petit « Wah-Pah » supplémentaire ! La création de chaque ensemble LEGO Ideas requiert une équipe de conception, non seulement pour que nous puissions être sûrs du résultat final, mais aussi pour concevoir le meilleur produit possible.

Qu'est-ce qui vous a le plus impressionnés dans le modèle original ?

Milan : Le modèle d'Aymeric comprenait tous les petits détails du café Central Perk, et je dis bien TOUS les détails ! Les seules choses qui manquaient étaient les angles bizarres. Comme il s'agit d'un plateau de télévision, les murs du Central Perk comportent des angles inhabituels pour que les caméras puissent capter plus d'images, ce qui donne une disposition de pièce vraiment intéressante. Après avoir visité le plateau du Central Perk à Los Angeles, j'ai pensé que ce serait une excellente occasion d'essayer de le recréer sous forme LEGO, et j'ai décidé de faire « pivoter » le mur !

Crystal : J'ai également été très impressionnée de voir à quel point la soumission du projet d'Aymeric était exhaustive ! J'ai beaucoup aimé les différentes versions des figurines qu'il a présentées et la quantité de détails qu'il a ajoutée dans son modèle.



De quelle partie du modèle êtes-vous le plus satisfaits ?

Milan : Central Perk est un endroit unique, et nous voulions vraiment créer quelque chose de spécial pour le 25^e anniversaire de *Friends*™. Nous avons intégré quelques techniques inhabituelles pour les fans de LEGO tout en essayant d'ajouter une bonne partie des excellentes références de *Friends*™ pour les fans de la série.

Crystal : Ma partie préférée est la fonction qui permet de retirer le coin canapé du modèle et de l'installer n'importe où avec les figurines ! Milan et moi avons aussi essayé d'ajouter autant d'œufs de Pâques que nous le pouvions à l'ensemble ! Et nous étions très heureux d'ajouter un écriteau « Réservé », qui est en fait un œuf de Pâques de l'un de ceux que l'on retrouve dans la série !



Para quienes vieron el show durante su emisión, cuesta creer que Friends™ tenga ya 25 años. Esta comedia de situación americana estuvo al aire durante diez temporadas, entre 1994 y 2004, retratando las vidas de seis amigos que vivían en la ciudad de Nueva York y pasaban mucho tiempo en una cafetería.

La premisa de la serie era fresca, inocente y atractiva, con un amplio recorrido. El humor y los chistes sencillos abundaban mientras el cómico grupo formado por Rachel, Ross, Joey, Chandler, Monica y Phoebe se enfrentaba a los retos y desafíos de la vida adulta. Pero el programa trataba también temas con los que cualquiera podía identificarse: el amor, el trabajo, la familia, el éxito, el fracaso, la manera de vivir la vida y, cómo no, la amistad. Era una comedia con argumento y corazón con la que conectaban fácilmente todas las audiencias, razón por la que las repeticiones siguen despertando un gran interés en todas las generaciones.

Este set LEGO® Ideas rinde homenaje al Central Perk, la cafetería en la que se reunían los personajes, con la particularidad de ser también el set de televisión que la representaba. Creado por Aymeric Fievet en colaboración con el equipo de LEGO Ideas, creemos que constituye un brillante tributo al fenómeno de Friends™. ¡Que disfrutes del episodio!





Ross Geller

Ross Eustace Geller es doctor en Paleontología y hermano de Monica. Ross, el personaje más académico del programa, es también un tipo de carácter dulce y estrafalario, además de un romántico empedernido. Tiene un hijo de una relación anterior, Ben, y un complicado pero irresistible romance intermitente con Rachel a lo largo de la serie. Entonces, ¿estaban en un *break* o no?



Rachel Green

Rachel Karen Green es la consentida pero bondadosa y simpática hija de un rico cirujano cardiovascular y su esposa. Rachel aparece en la serie en el primer episodio, después de dejar a su prometido, Barry, plantado en el altar, e intenta vivir por su cuenta trabajando como mesera. Rachel y Ross tienen mucha química y su relación intermitente es un tema recurrente a lo largo de toda la serie.



Monica Geller

Monica E. Geller-Bing es la hermana menor de Ross y la mejor amiga de Rachel, con quien también comparte departamento. Trabaja como chef en diferentes restaurantes. A Monica se la describe como la mamá gallina del grupo y es conocida por su naturaleza competitiva. Más adelante contrae matrimonio con Chandler.



Joey Tribbiani

Joseph Francis "Joey" Tribbiani Jr. es un actor de buen corazón y un gran amante de la comida que se hace moderadamente famoso por su papel como el Dr. Drake Ramoray en la serie ficticia para televisión *Los días de nuestra vida*, basada en un hospital. Joey es el compañero de departamento de Chandler durante la mayor parte de la serie y muy popular entre las chicas, a las que acostumbra dedicar su frase característica para romper el hielo: "¿Cómo va eso?"



Chandler Bing

Chandler Muriel Bing, compañero de departamento y eterno cómplice de Joey, es un tipo sarcástico pero dulce que deja su trabajo de ejecutivo con traje en una gran corporación multinacional para convertirse en pasante y, más tarde, en redactor *junior* de una agencia de publicidad. Algo surge entre Chandler y Monica... y luego se casan.



Phoebe Buffay

Phoebe Buffay es una masajista ingenua y dulce que creció sin hogar. Aspira a dedicarse a la música y, mientras, toca la guitarra y canta canciones con letras un poco inusuales en la cafetería.



CONOCE AL FAN DISEÑADOR

Aymeric Fievet vive en Normandía (Francia) y trabaja en el sector de las computadoras desde hace una década. Como el cinéfilo extremo que es, le apasionan las series, las películas y los dibujos animados, así como los productos LEGO®, por supuesto.

“Juego con productos LEGO desde muy joven y he coleccionado muchos sets. Mi colección sigue evolucionando y me interesa particularmente la serie Minifigures.

Uno de los sets que permanecen en mi corazón es Monorail Transport Base (6991). Tengo muy buenos recuerdos de ese set porque combinaba mis dos cosas favoritas cuando era niño: los trenes y el espacio.

Mi elemento LEGO favorito es el brick 1x2 con textura de ladrillos (98283), que descubrí en el set The Big Bang Theory™. Me parece fundamental para crear edificios, casas, castillos y mi Central Perk, por supuesto.



Orienté mi proyecto hacia una de mis series favoritas: Friends™. El desafío era ver secuencias de la serie que me permitieran recrear el mobiliario y los personajes con el mayor detalle posible.

Construir el modelo me llevó alrededor de una semana desde que encontré las referencias necesarias. Durante el período de votación, modifiqué varias veces el set.

No podría explicar lo que sentí cuando llegué a los 10.000 votos: fue una mezcla de alegría y orgullo.



Para que un proyecto LEGO® Ideas tenga éxito, hay que creer en uno mismo, ser paciente y no dudar en pedir ayuda en caso de necesitarla, porque hay muchas personas preparadas y dispuestas a colaborar.

Lo que me gusta de LEGO Ideas es que te da la oportunidad de usar la imaginación realmente y, si tienes éxito, ¡ver tu nombre asociado a tu marca favorita! Además, es divertido y fácil de usar. Siempre es un placer descubrir nuevas creaciones cada día.

Mi consejo para quienes presentan ideas es: ¡sepan que su sueño es posible! Y cuiden mucho el aspecto de sus fotos porque son su mejor publicidad”.

CONOCE A LOS DISEÑADORES DE LEGO®

Milan Madge: diseñador

Crystal Bam Fontan: diseñadora gráfica

¿Cuál fue su reacción cuando les pidieron que trabajaran en este proyecto?

Milan: Cuando era más joven, dividía mi tiempo cuidadosamente entre dos tareas: jugar con bricks LEGO® y ver Friends™. ¡Digamos que esto no podía parecerme más emocionante!

Crystal: Soy una verdadera fanática de Friends™, así que, cuando se confirmó que el proyecto saldría adelante, me convertí en una Janice total y me puse en plan "¡OH... DIOS... MÍO!".



Crystal y Milan saborean un café en el decorado del Central Perk.

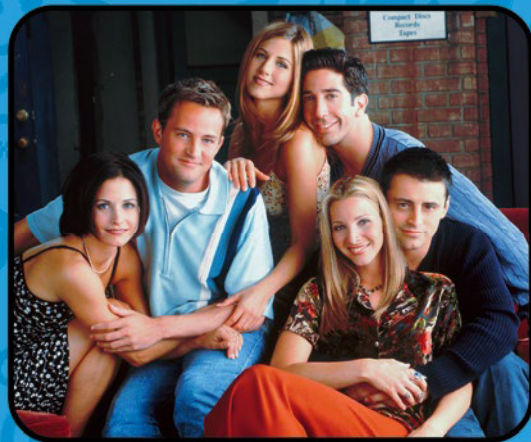

¿En qué se diferencia este de sus otros proyectos en LEGO?

Milan: Fui fan de LEGO durante años y sé que la idea de contribuir a un producto LEGO oficial habría sido un sueño para mí. Tratar de hacer realidad ese sueño para fans como Aymeric es de lo que se trata este trabajo.

Crystal: Trabajar con LEGO Ideas es un poco más personal, ya que queremos que el fan con el que trabajamos y la comunidad de fans en general se sientan orgullosos de los productos que creamos.

¿Por qué intervienen diseñadores profesionales de LEGO® en este proceso? ¿Cuál es su función?

Milan: ¡Mi función en este proyecto fue incluir el mayor número posible de referencias a Friends™ en el vocabulario del equipo de diseño! En realidad, el papel del diseñador de LEGO consiste en partir del prototipo del fan diseñador y aplicarle nuestro riguroso proceso de control de calidad para proporcionarles a los fans la impresionante experiencia de construcción que esperan de un producto LEGO oficial. Se requiere un cierto grado de *unagi*.

Crystal: Como diseñadora gráfica, mi trabajo consistió en convertir en minifiguras al inconfundible elenco de Friends™, así como en diseñar adornos que le dieran al set ese toque extra de comedia. Todos los sets LEGO Ideas requieren un equipo de diseño que los respalde y garantice que el resultado final sea seguro y se corresponda con el mejor producto que podamos lograr.

¿Qué es lo que más les impresionó del modelo original?

Milan: El modelo de Aymeric capturaba hasta el más pequeño de los fantásticos detalles del Central Perk; ¡no faltaba ni uno! Solo necesitaba un par de modificaciones para corregir algunos ángulos inusuales. Al ser un set de televisión, las paredes del Central Perk están en ángulo para que las cámaras puedan abarcar más, lo que da lugar a una distribución realmente interesante del espacio. Después de visitar el set del Central Perk en Los Ángeles, pensé que sería una gran oportunidad para reproducirlo en formato LEGO y decidí hacer que la pared girara.

Crystal: ¡También me impresionó mucho lo minuciosa que era la propuesta de Aymeric! Me encantaron las diferentes versiones de las minifiguras que presentó y el nivel de detalle que incluyó en la distribución de su modelo.



¿Con qué parte del modelo están más satisfechos?

Milan: El Central Perk es un lugar excepcional y realmente queríamos probar algo especial para el 25 aniversario de Friends™. Incluimos algunas técnicas inesperadas para los fans de LEGO y logramos capturar muchas referencias fantásticas para los fans de Friends™.

Crystal: ¡Mi parte favorita es la función que te permite sacar del modelo la zona del sofá y exhibirla con las minifiguras donde quieras! Milan y yo intentamos añadir también al set tantas sorpresas como pudimos. Nos encantó incluir el letrero de reservado, ¡que es una sorpresa basada en otra sorpresa de la serie!

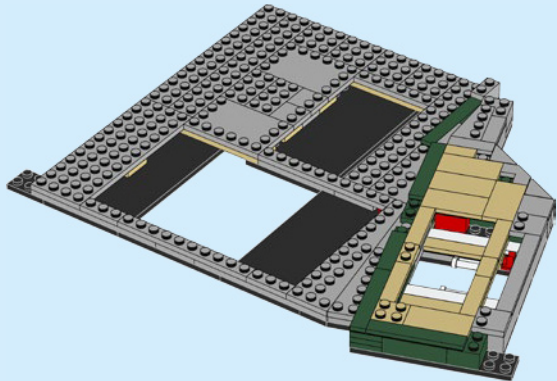
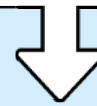
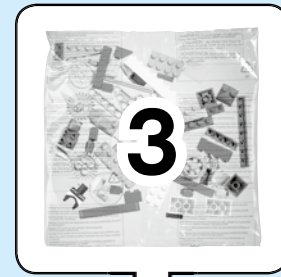
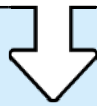
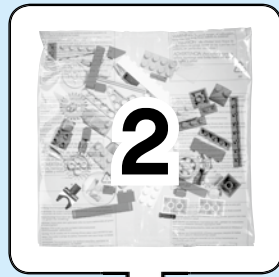
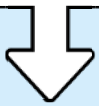

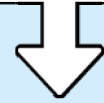
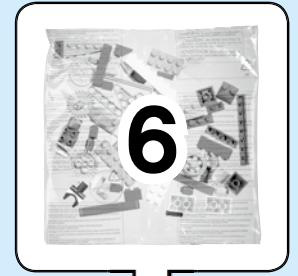
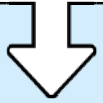
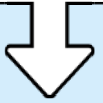
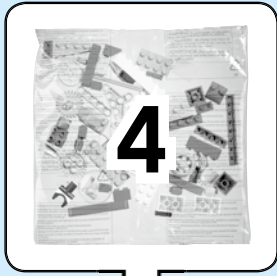

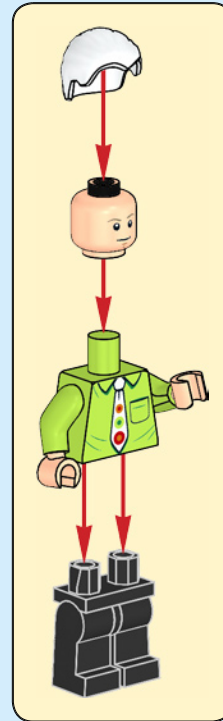
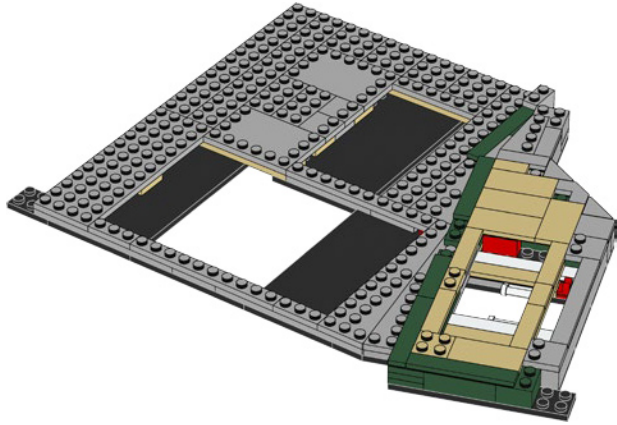
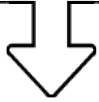

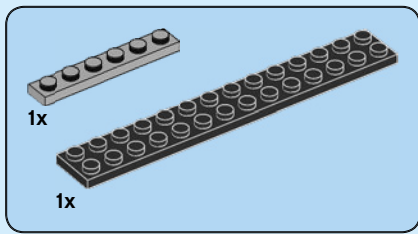

1

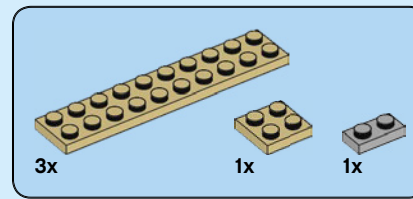
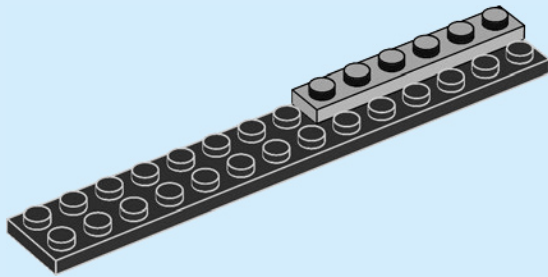

2

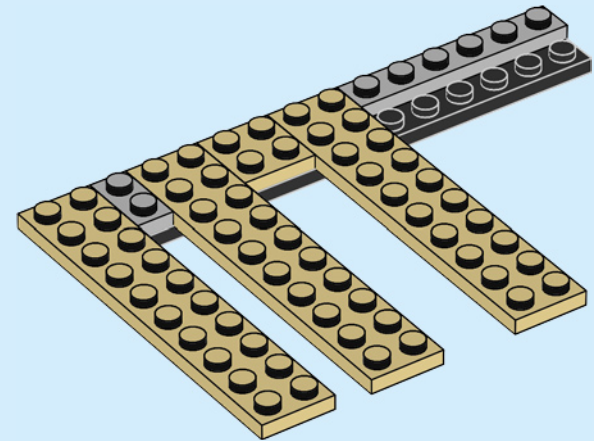

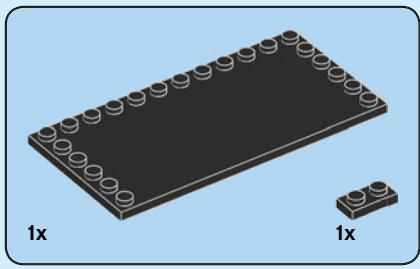

3

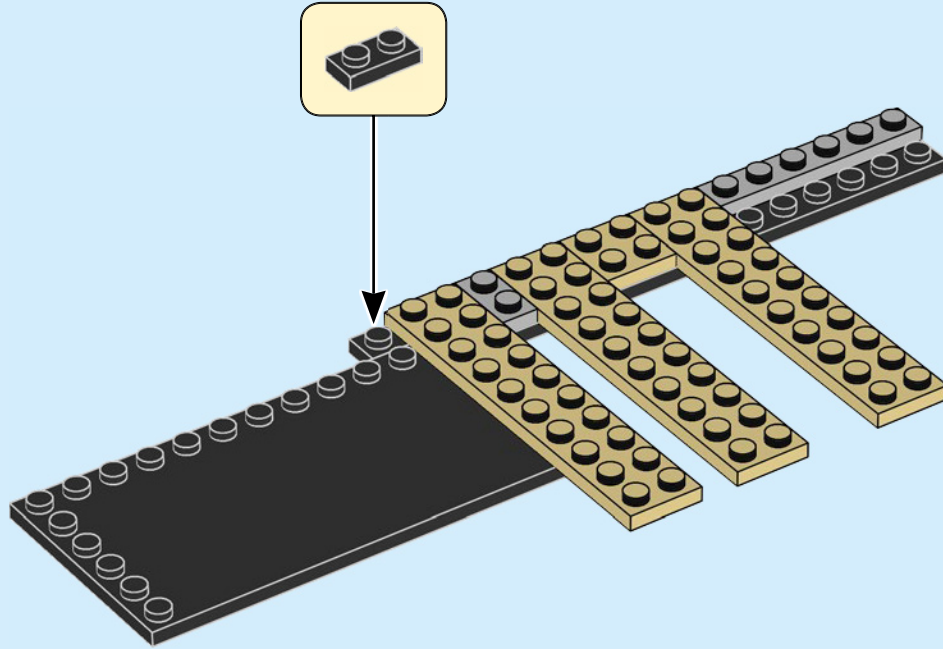

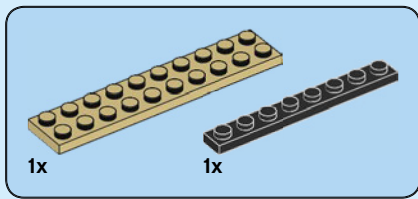

4

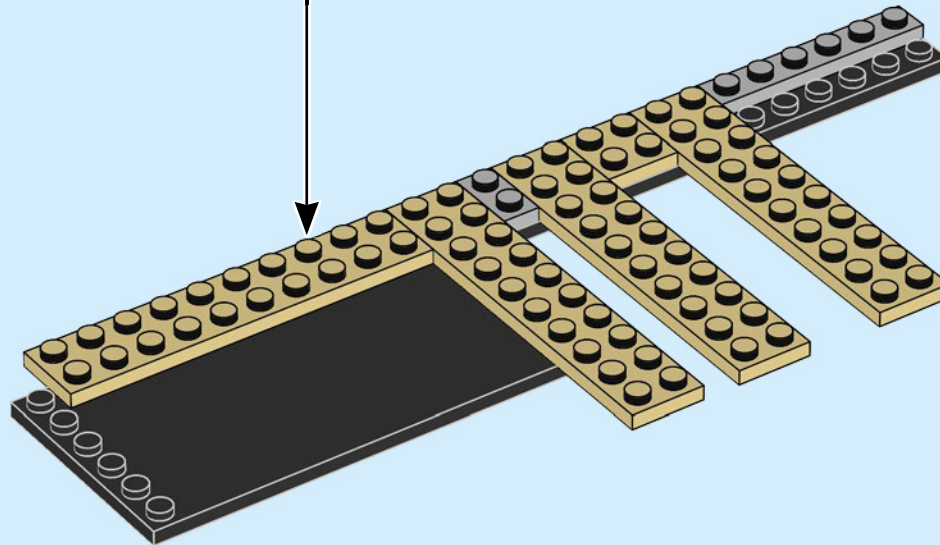
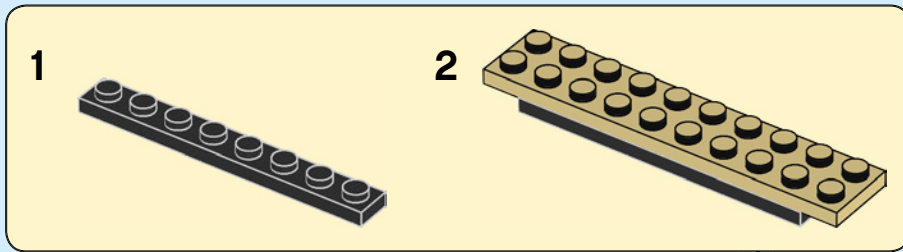

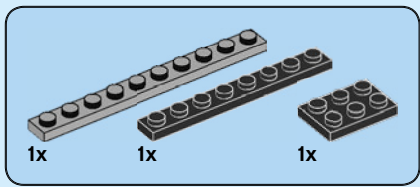

5

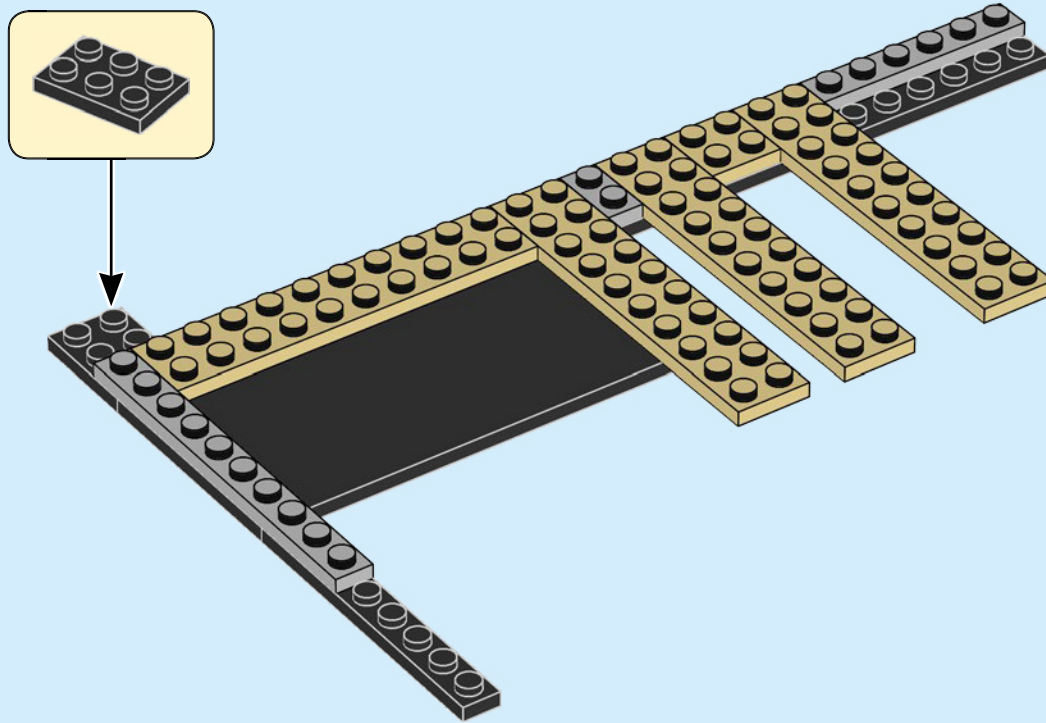

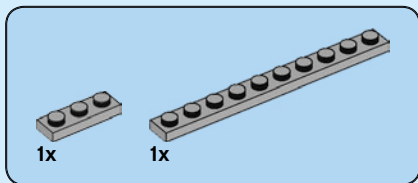

6

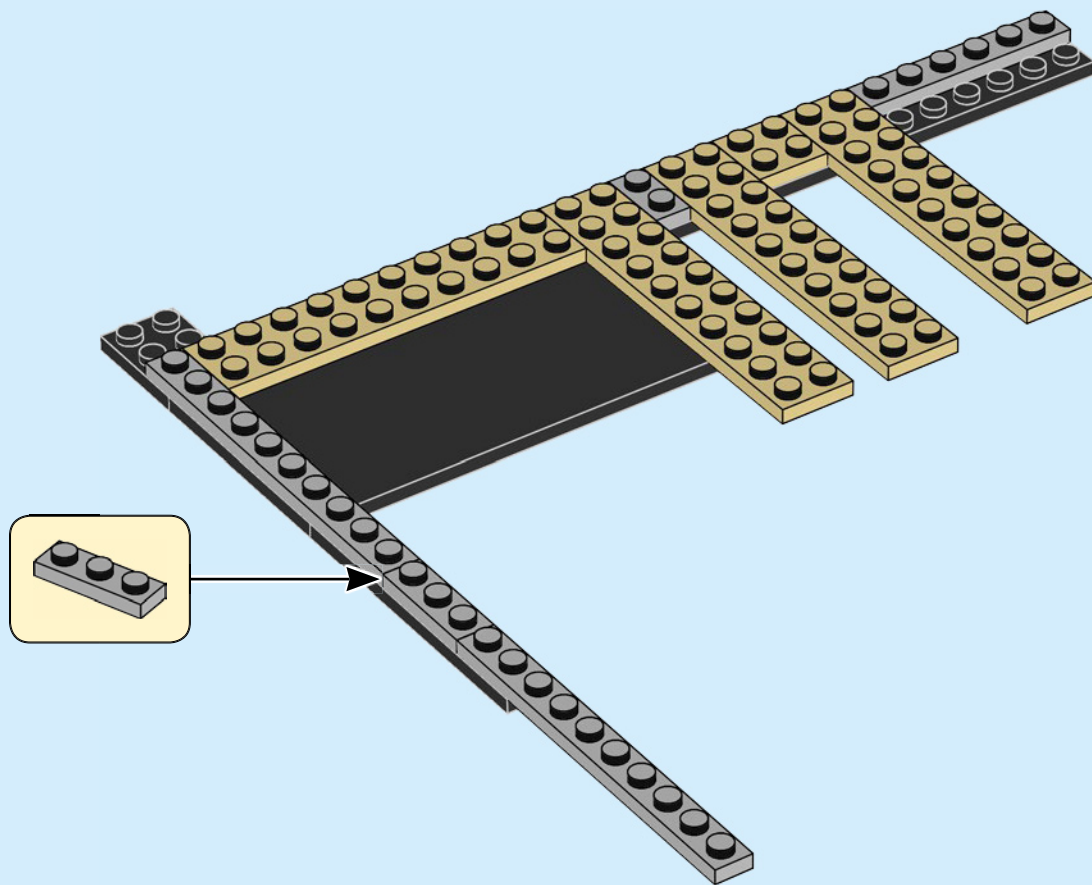

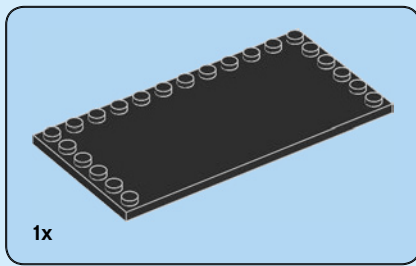

8

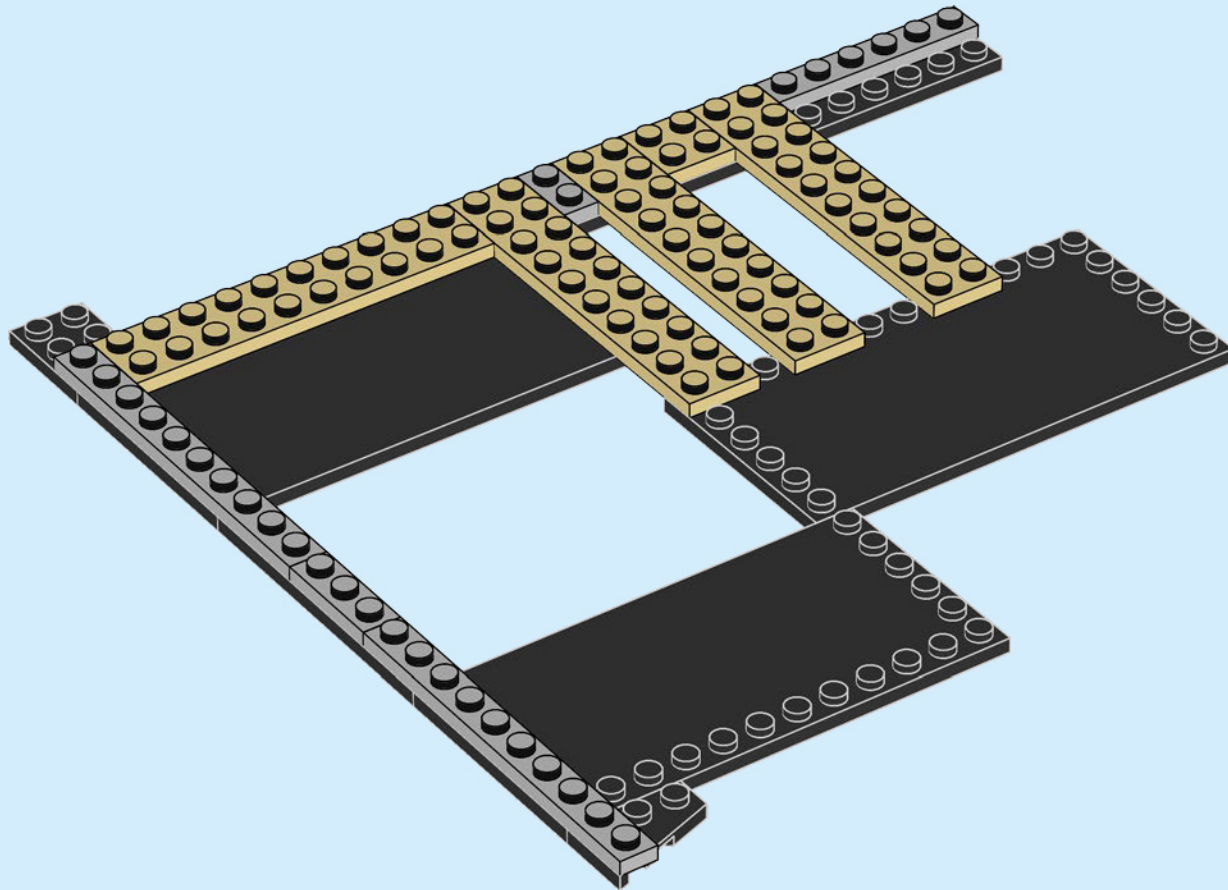

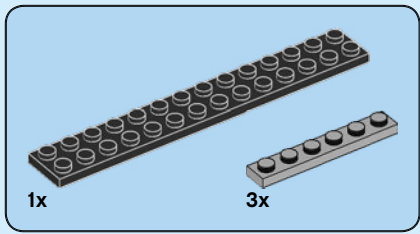

9

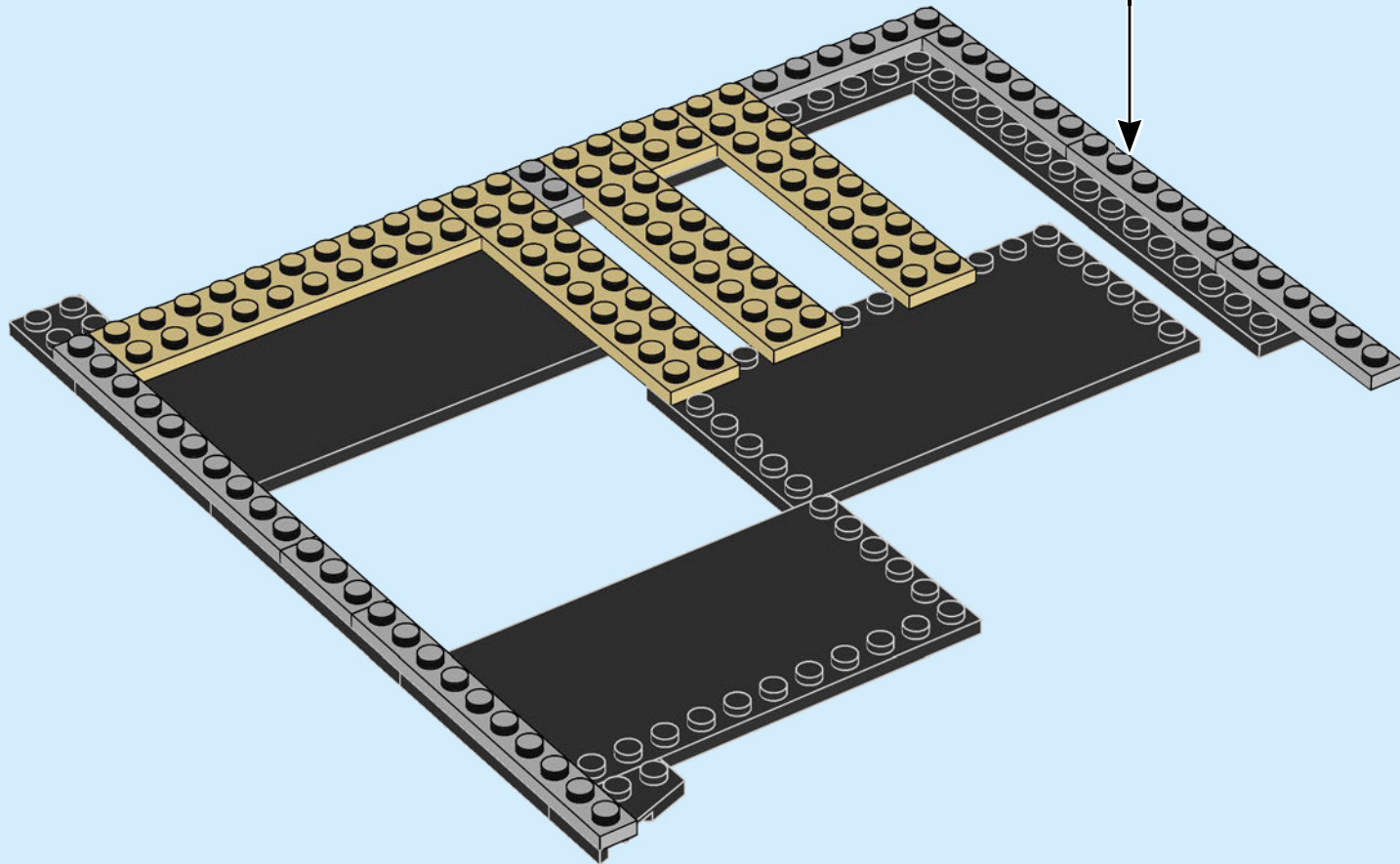
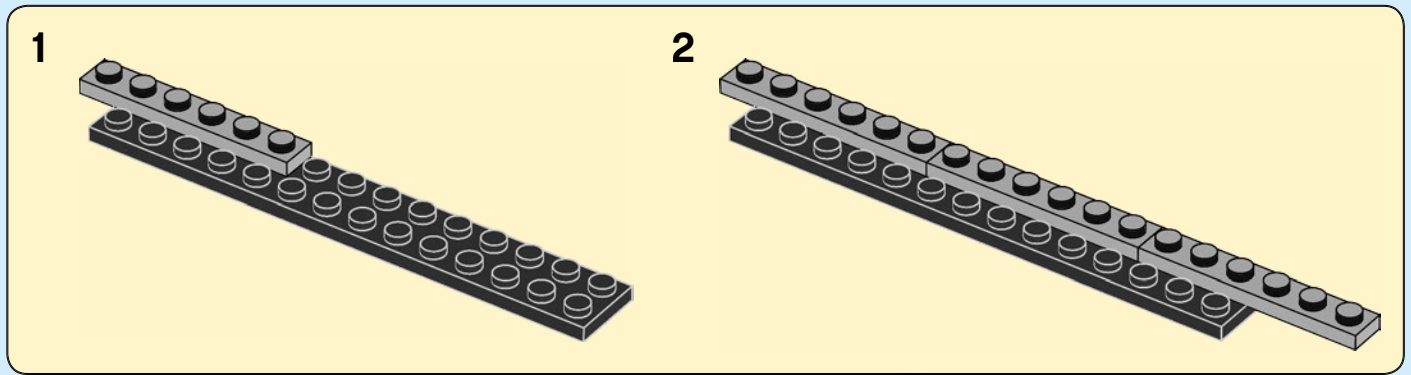

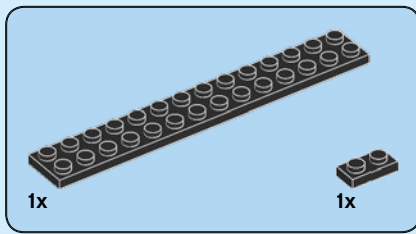

10

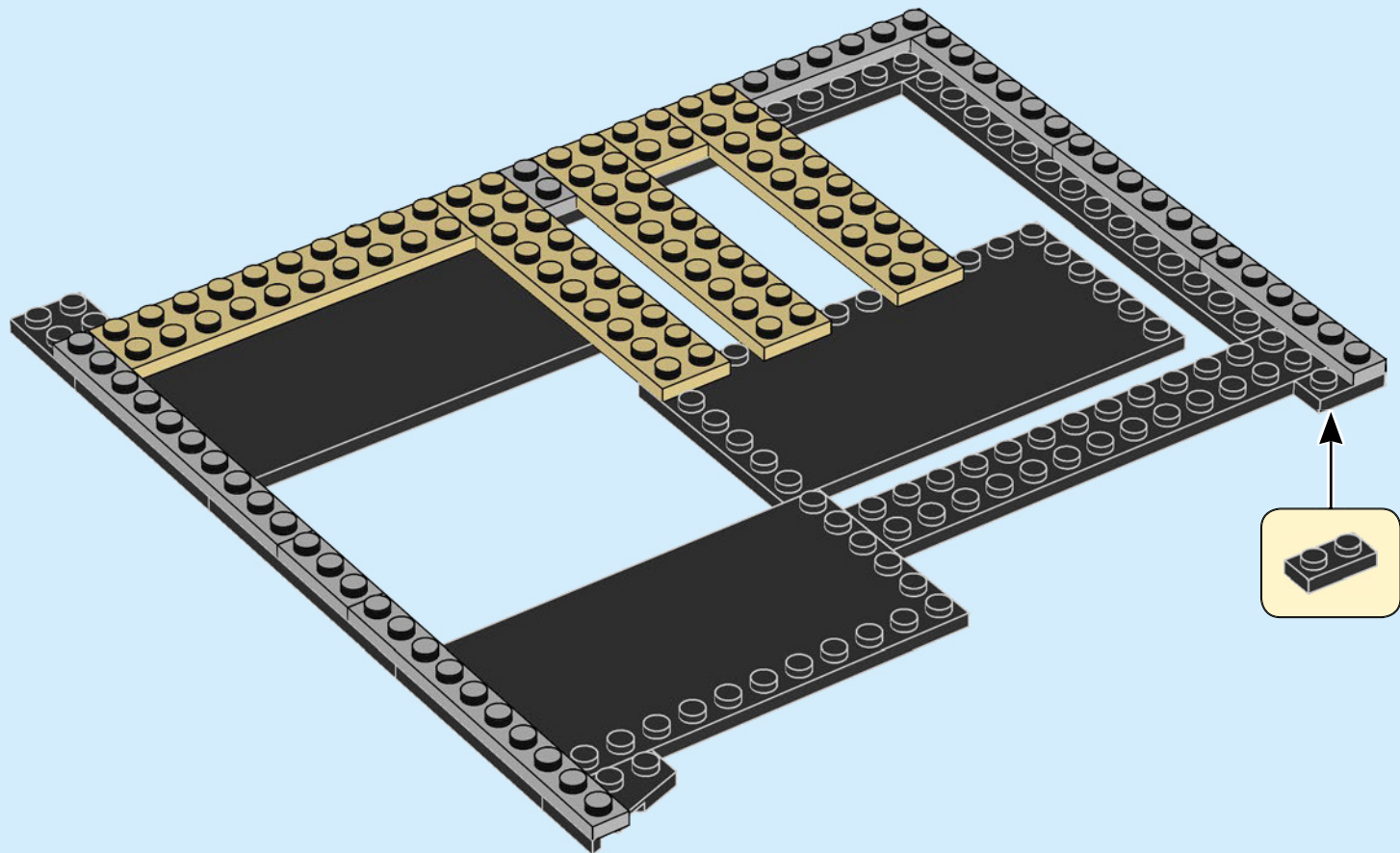

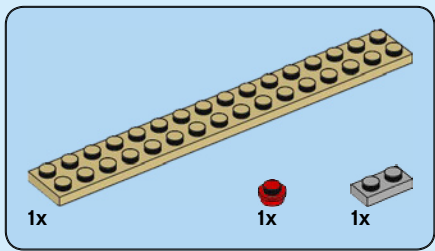

11

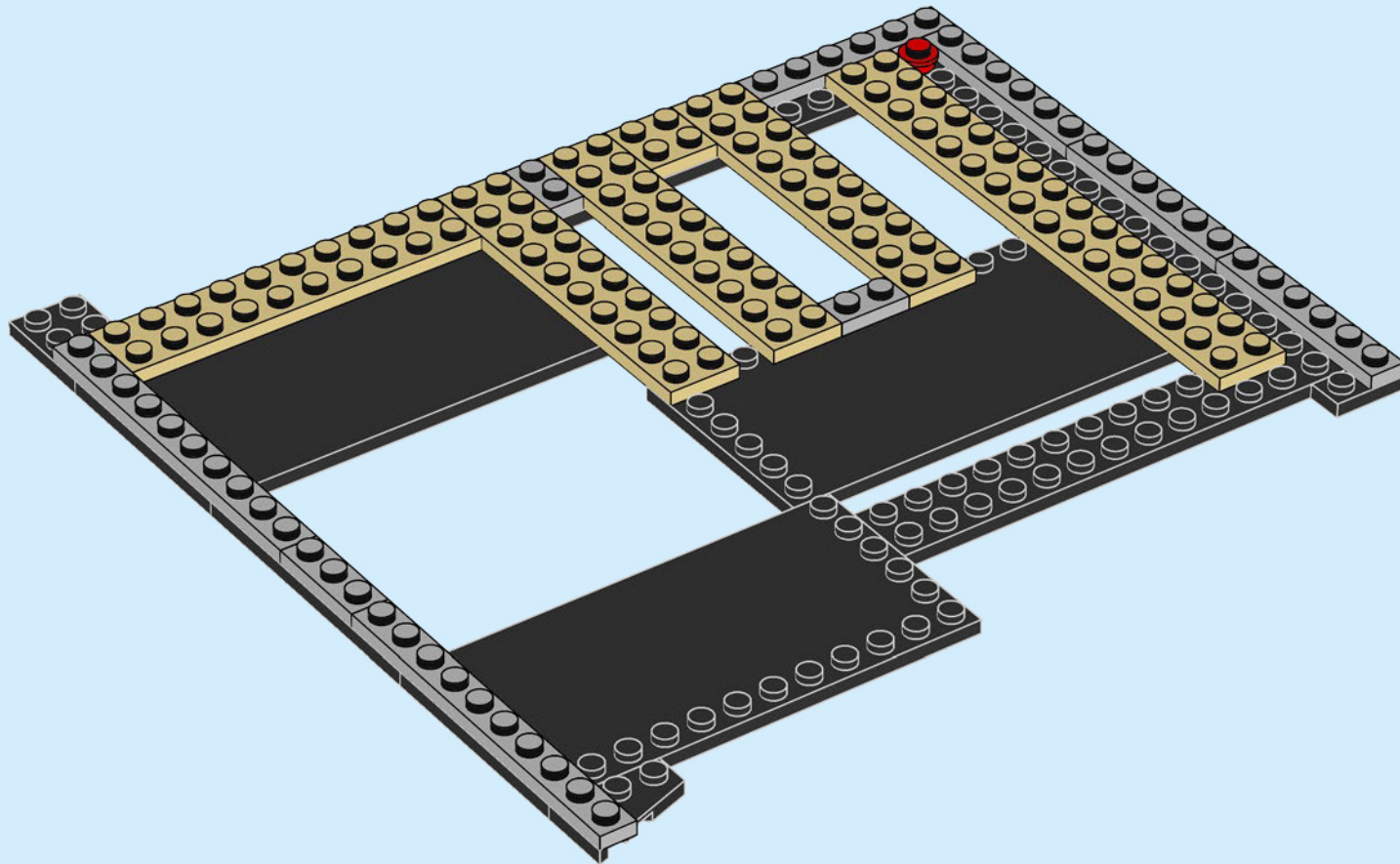

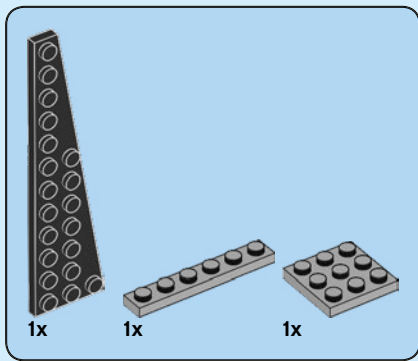

12

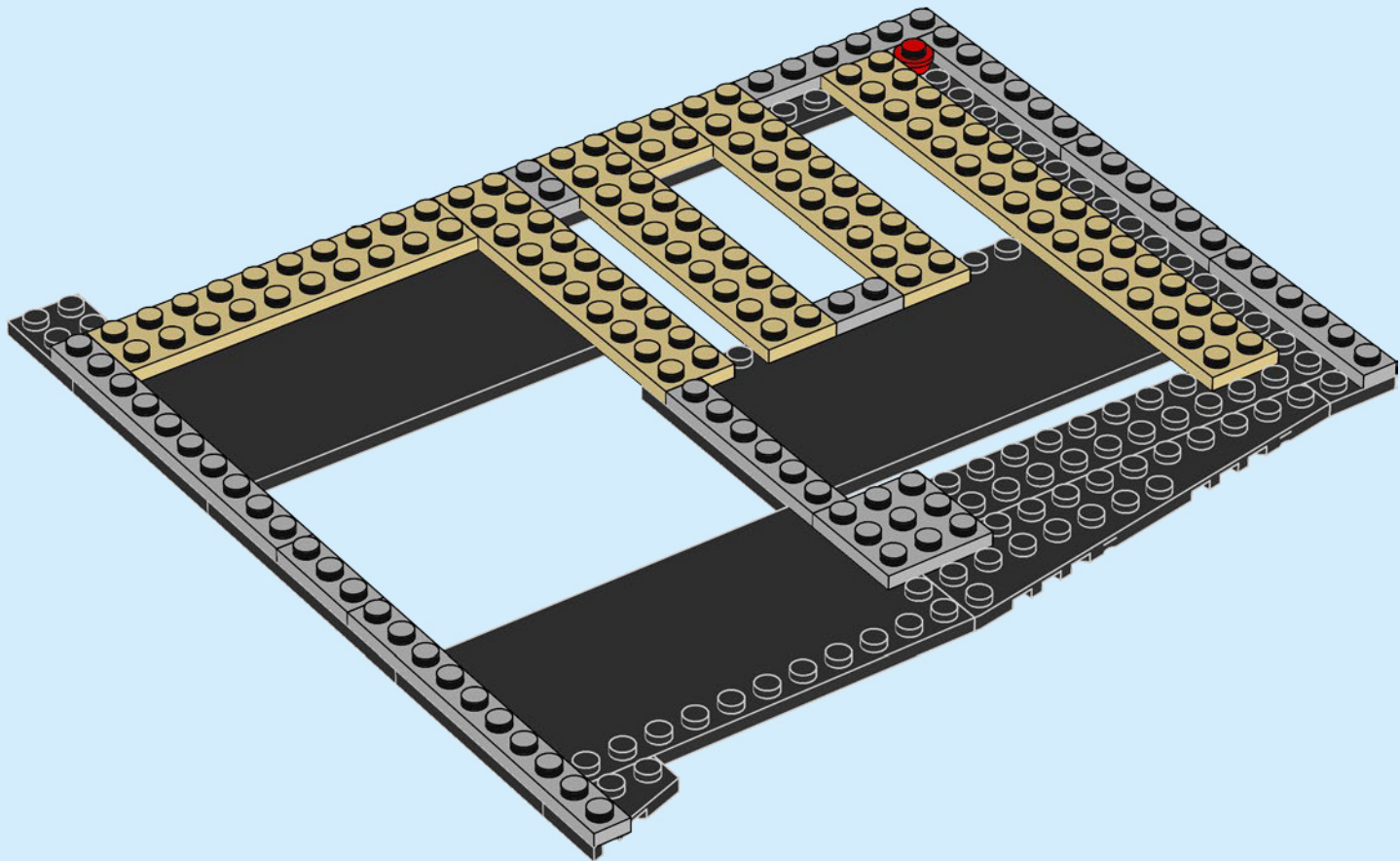

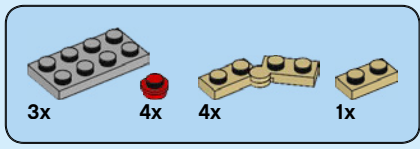

13

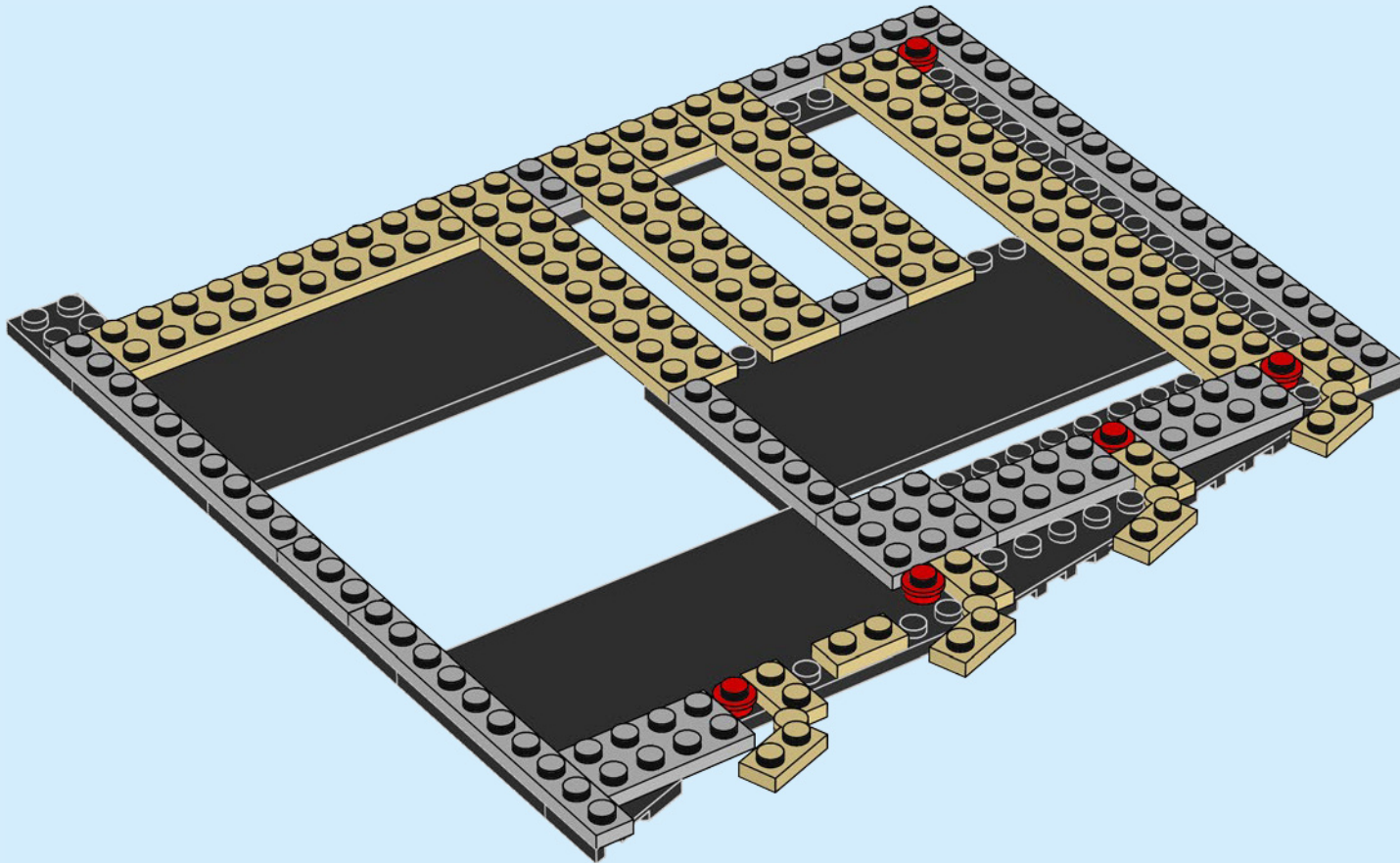

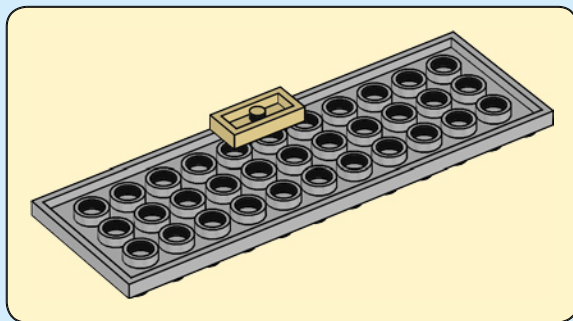
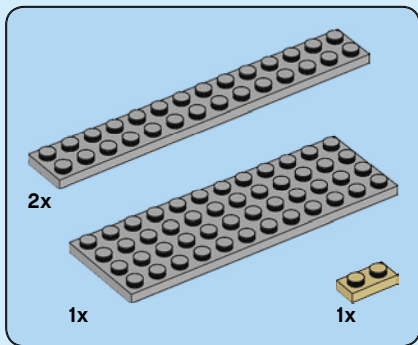

14

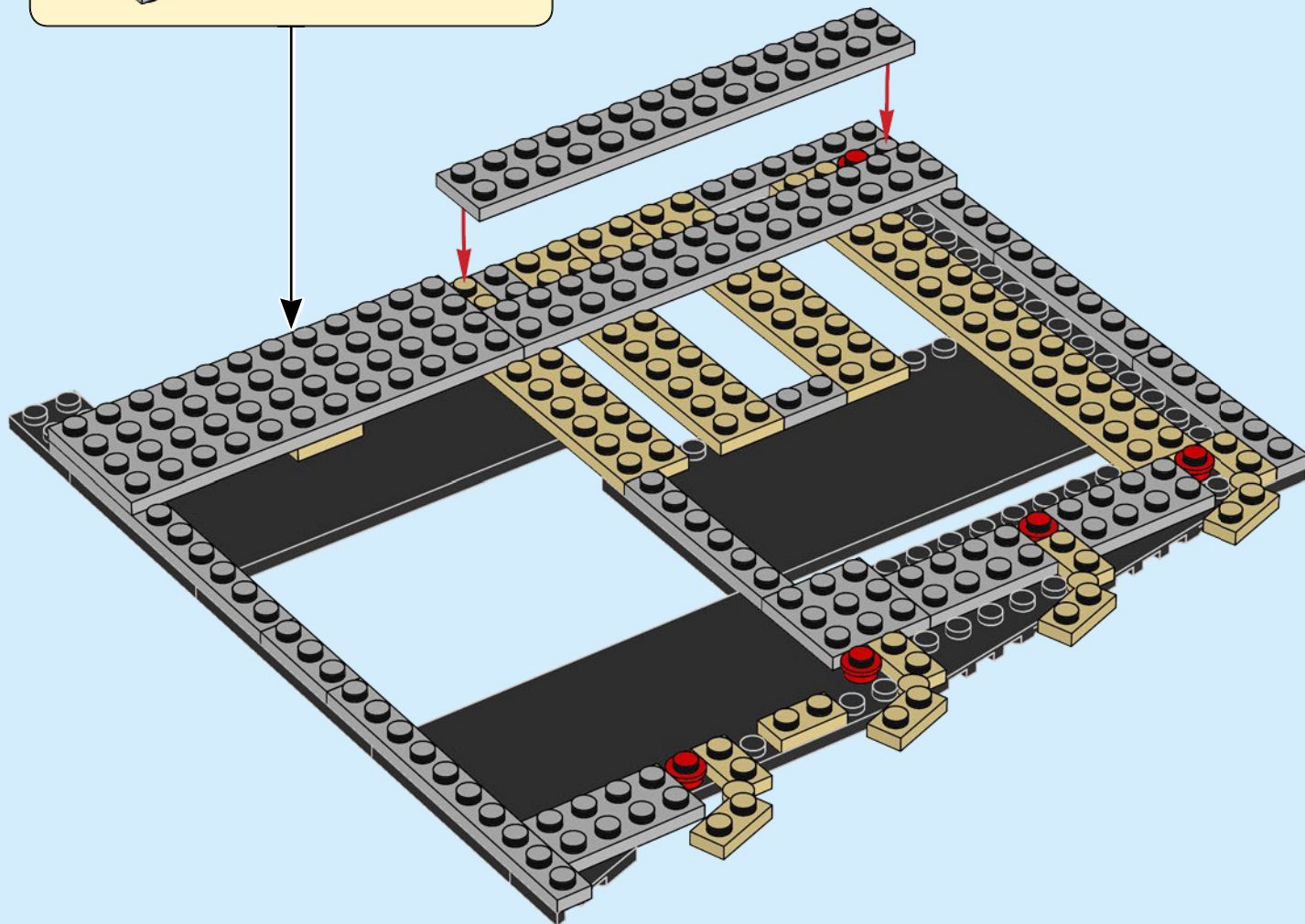

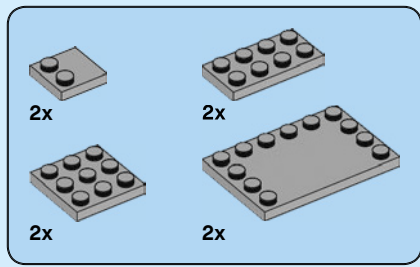

15

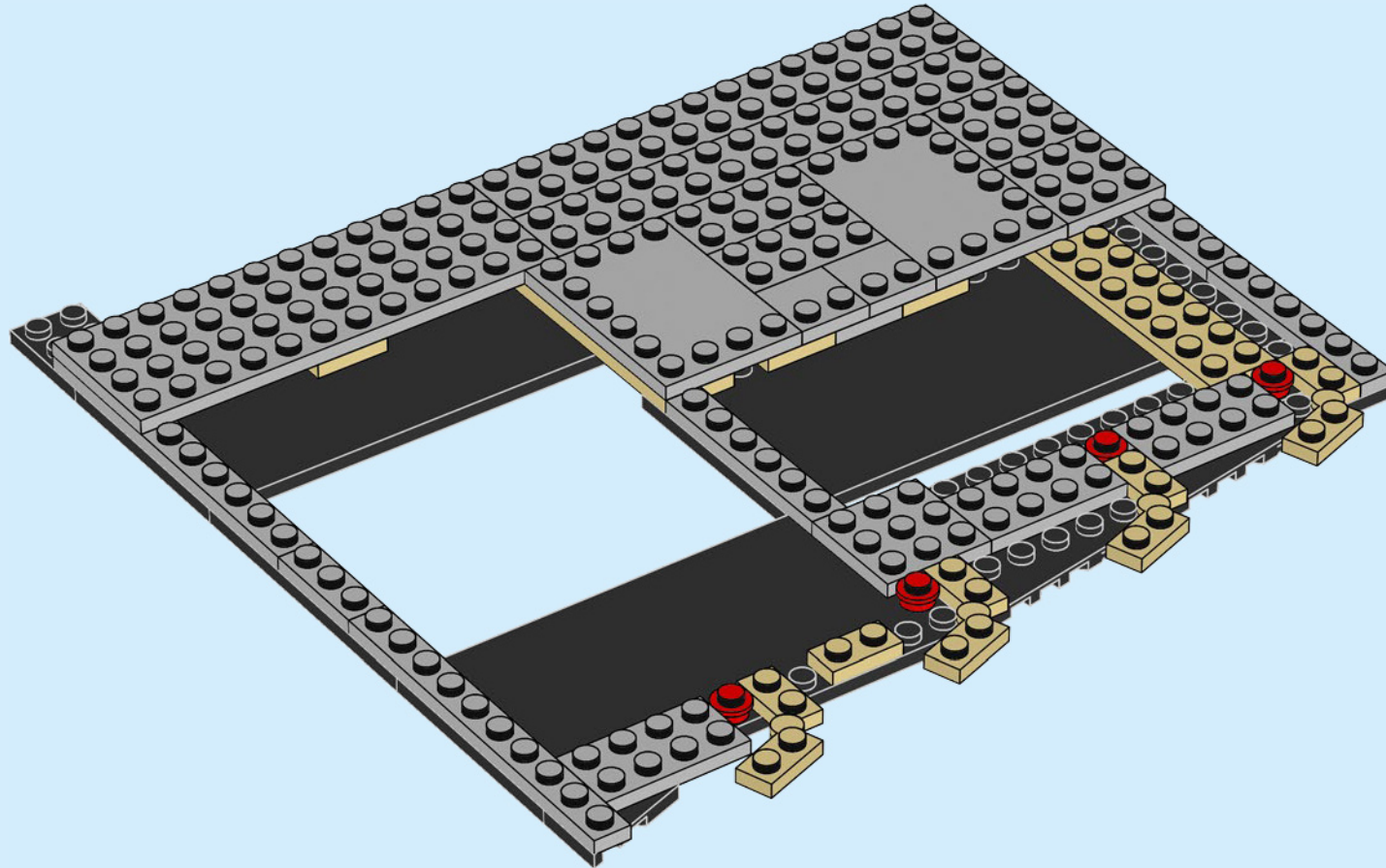

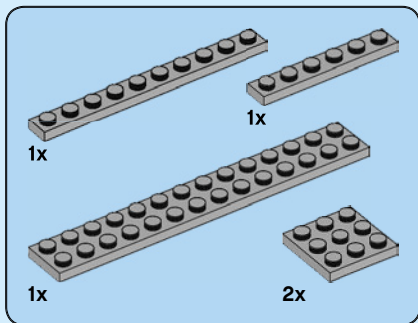

16

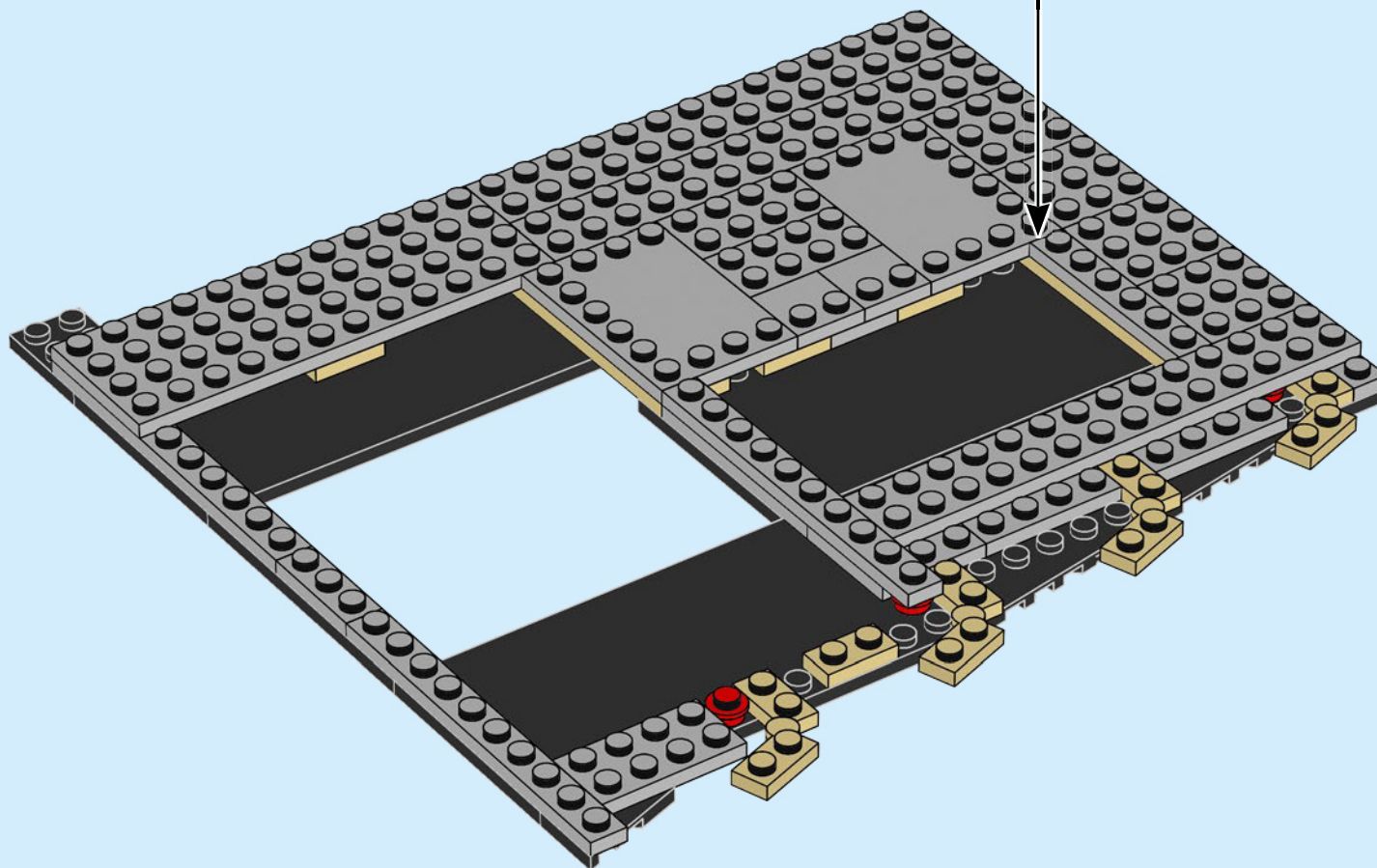
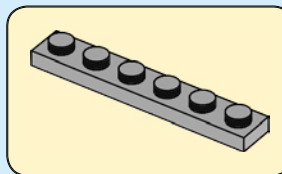

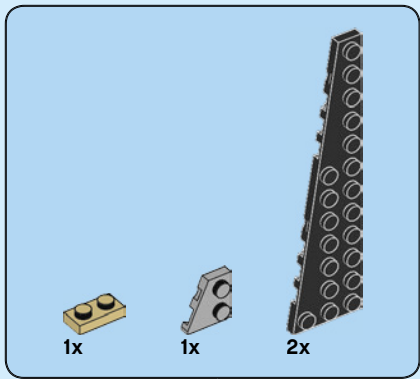

17

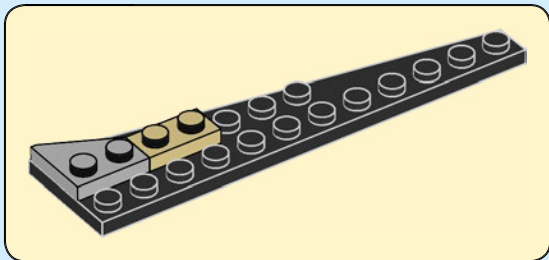
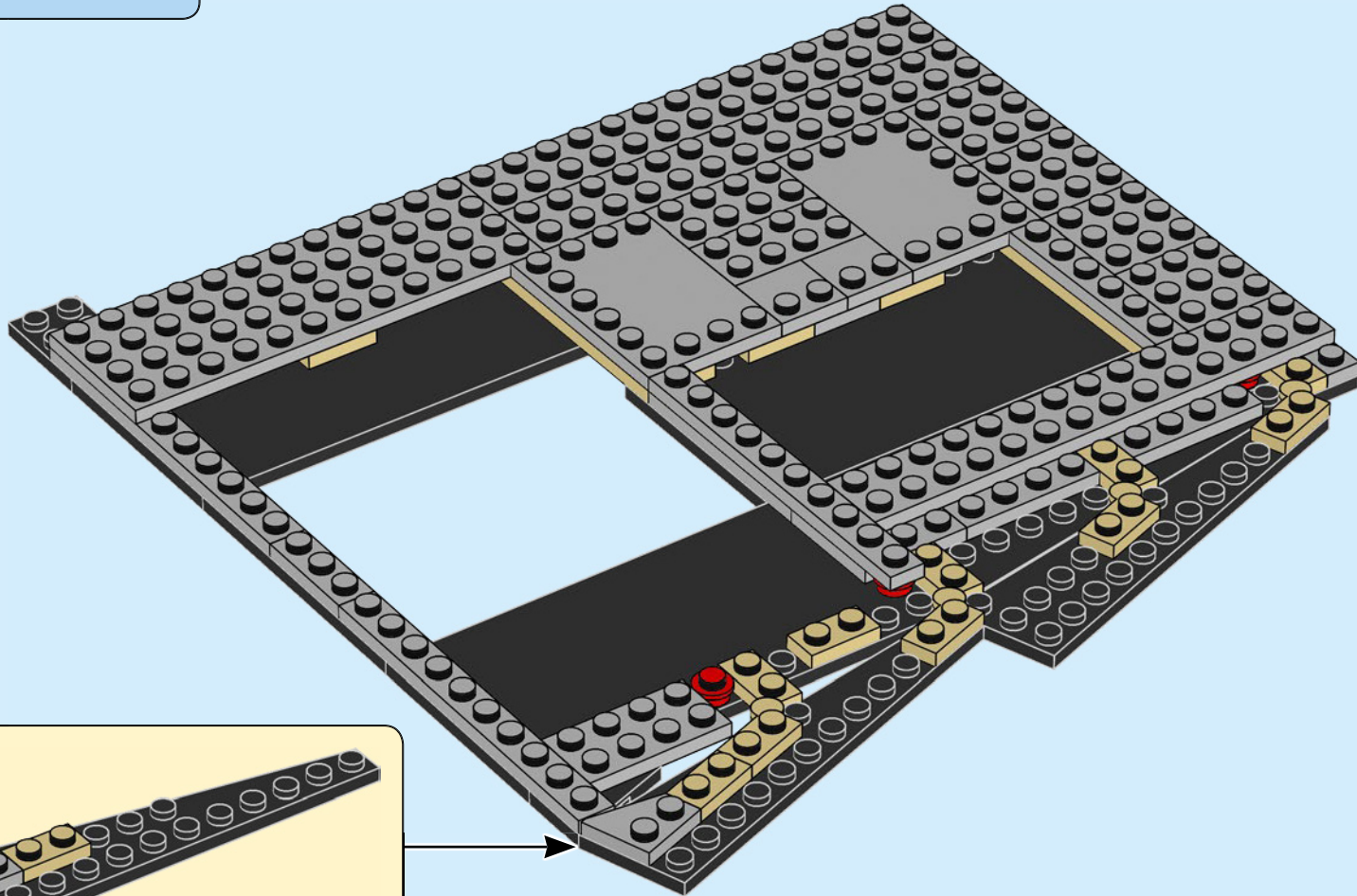

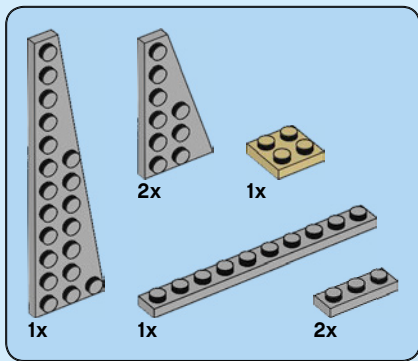

18

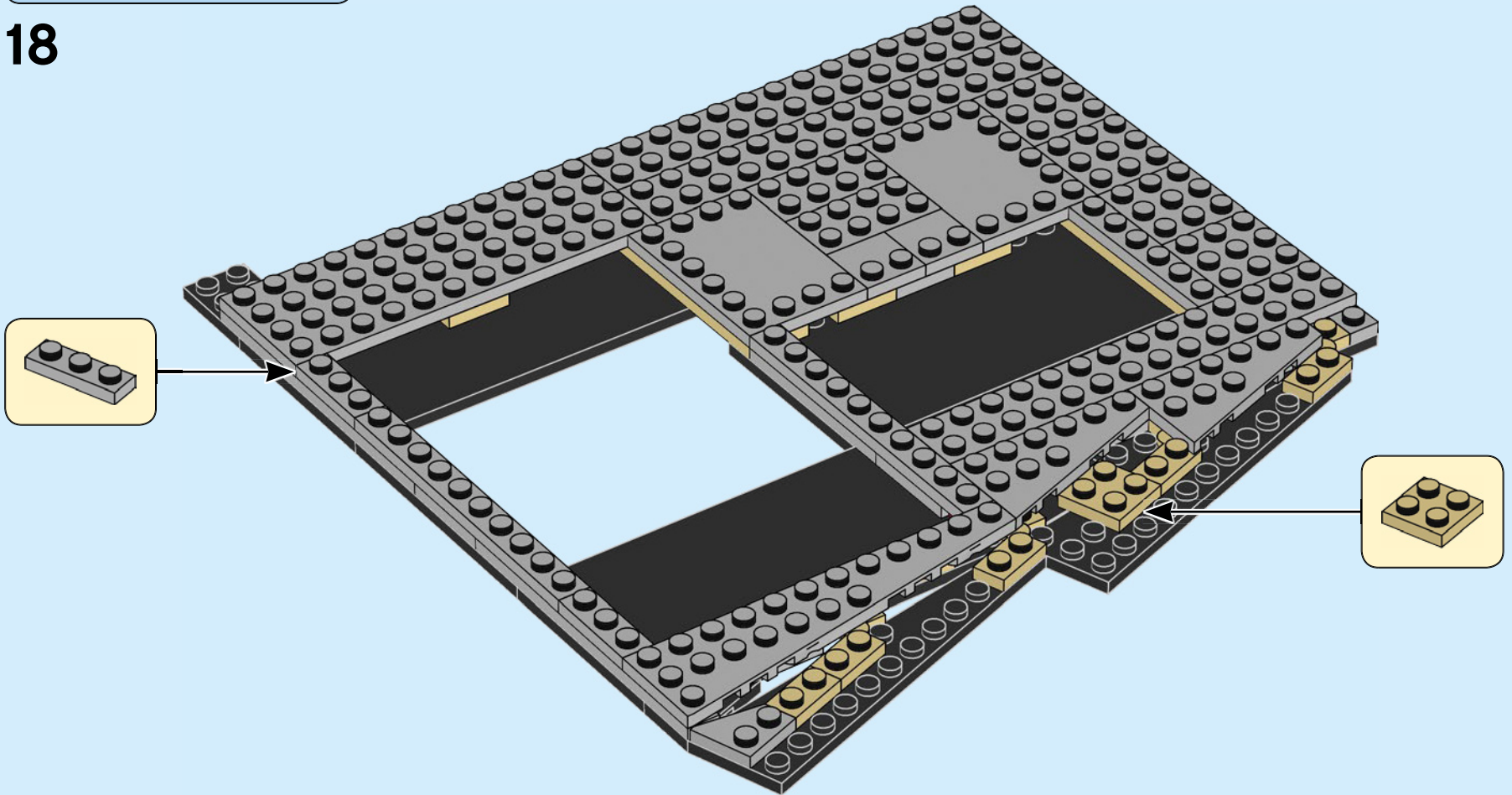

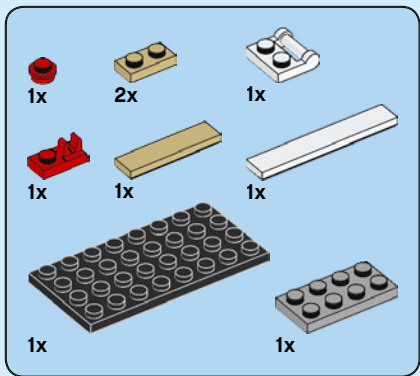

19

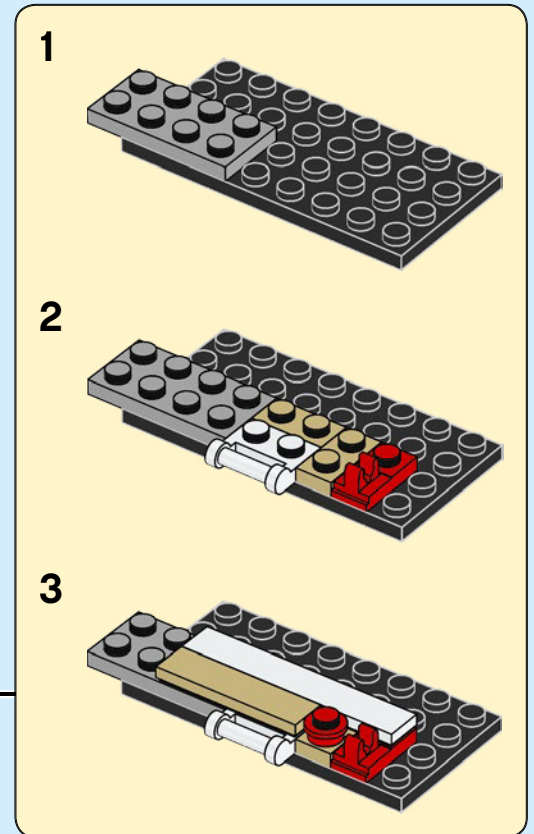
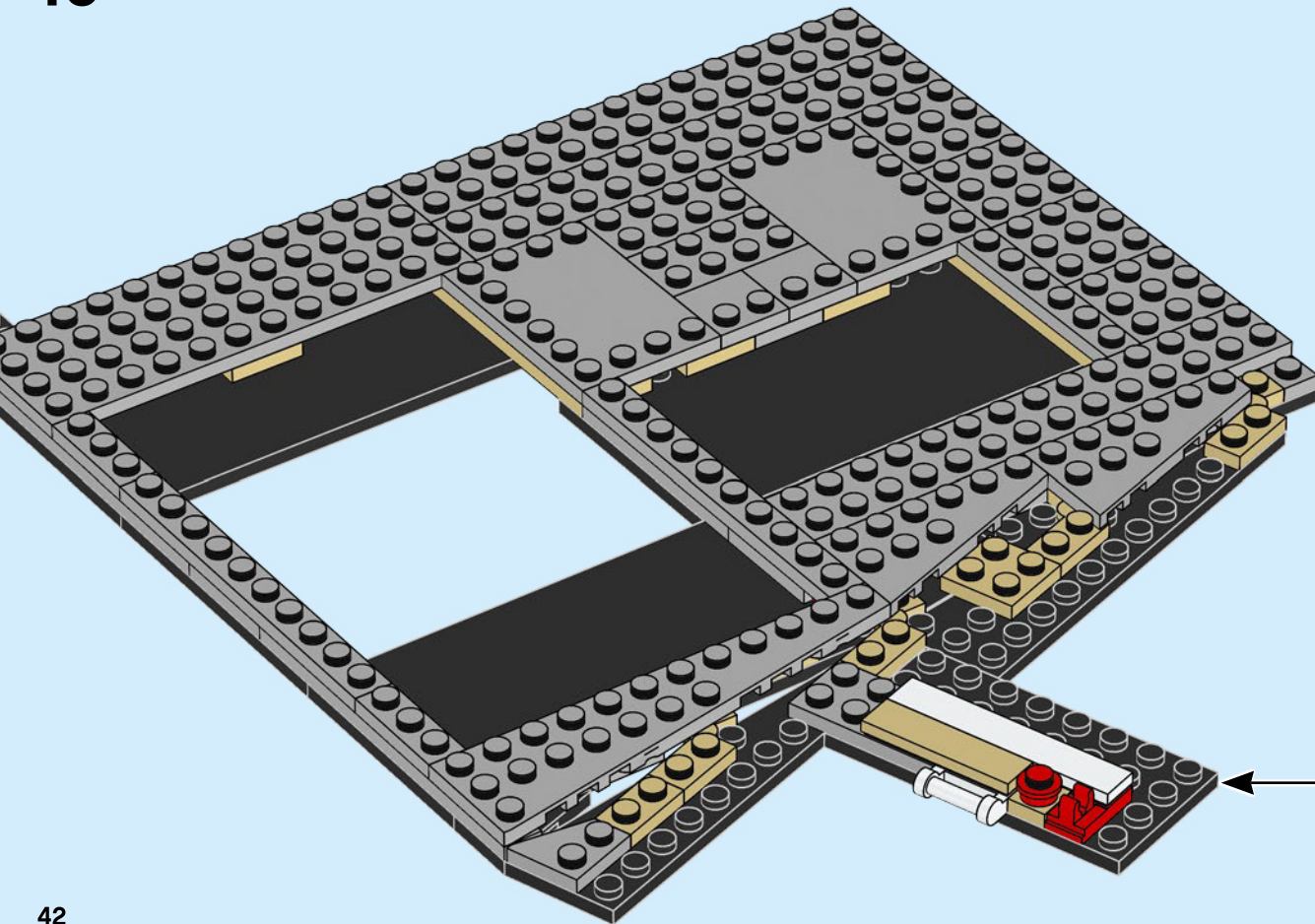

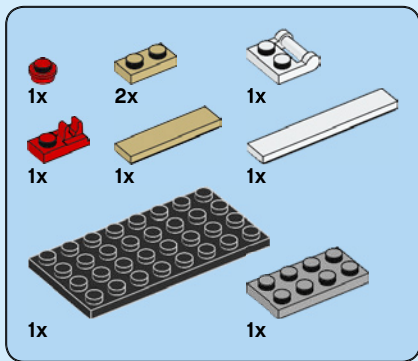

20

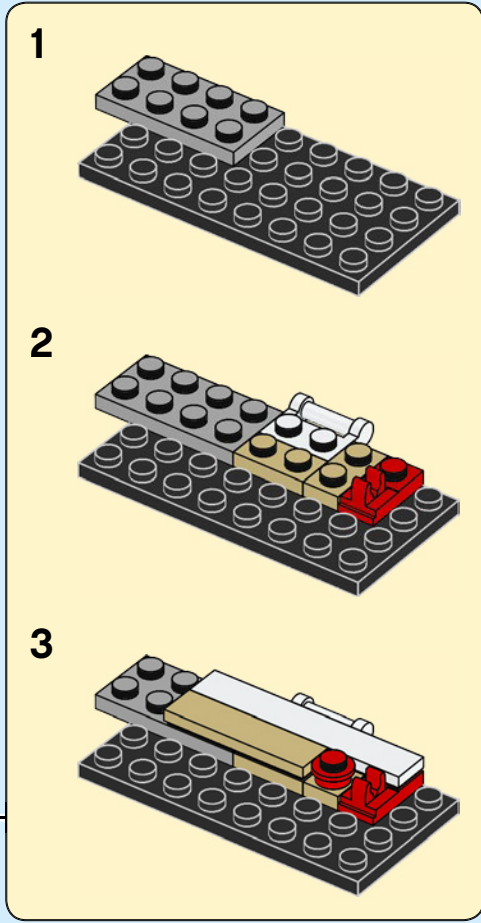
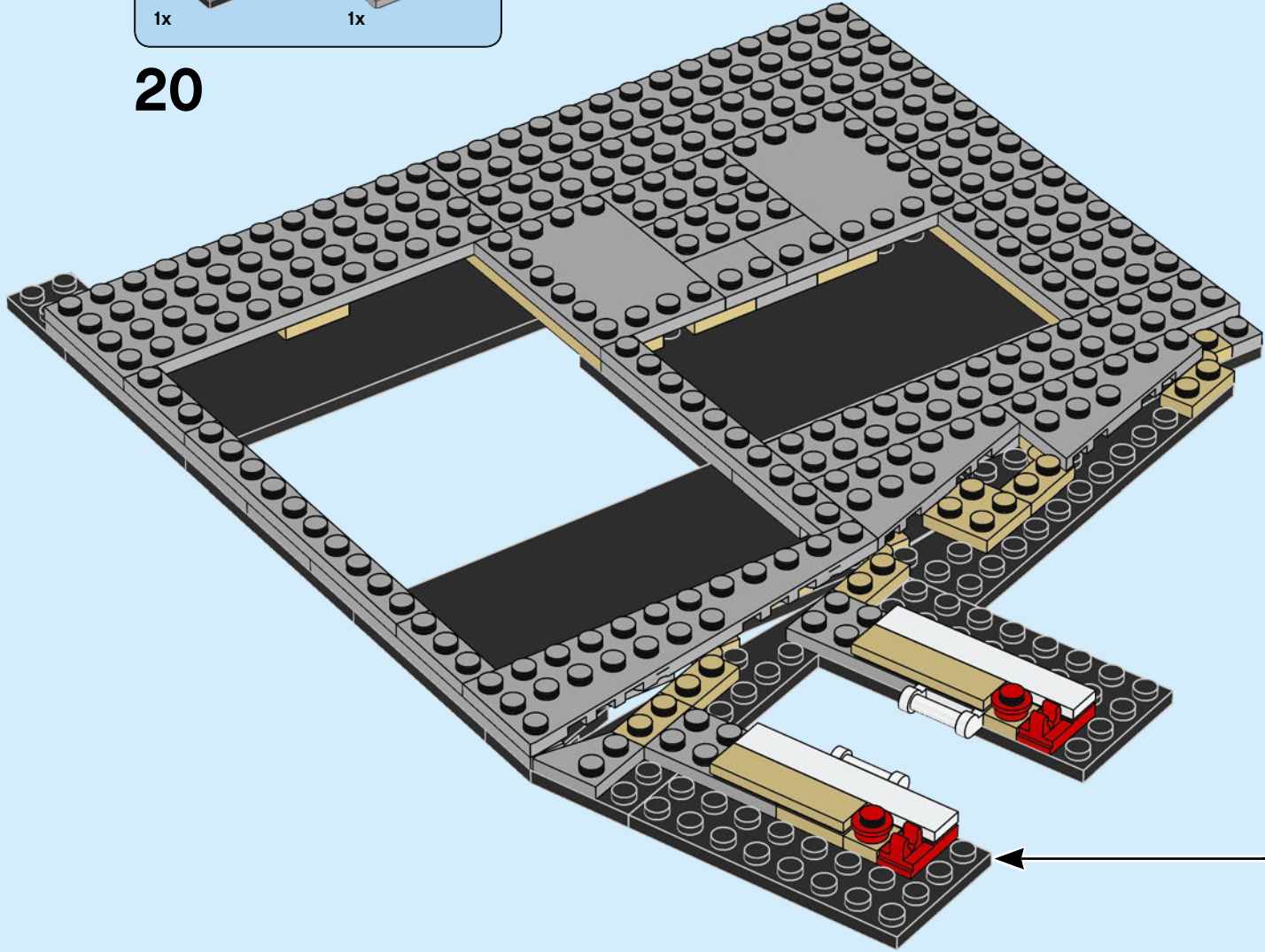

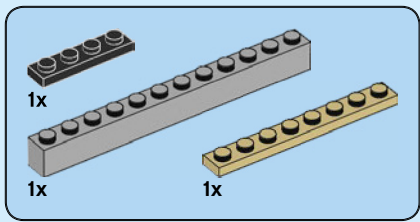

21

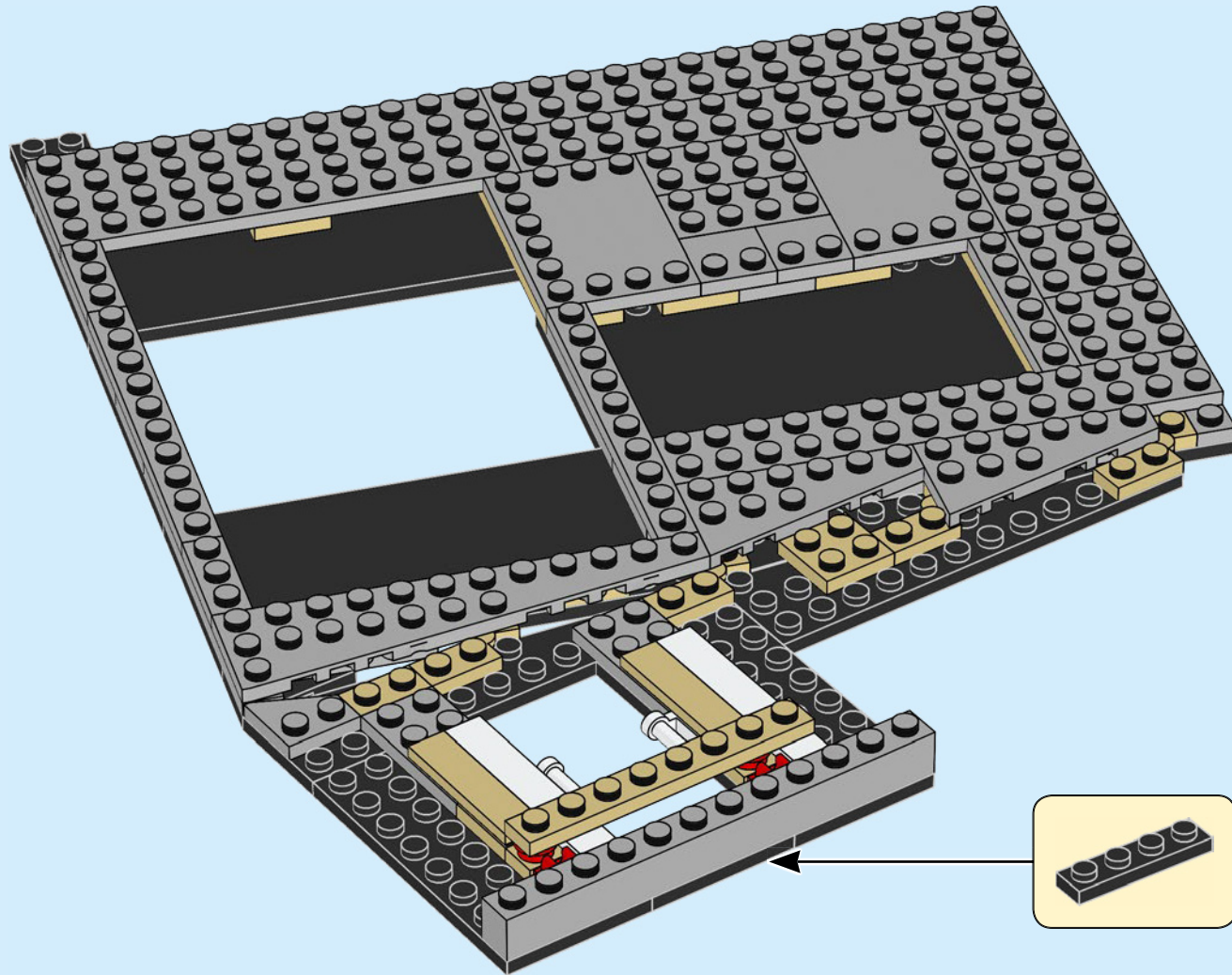

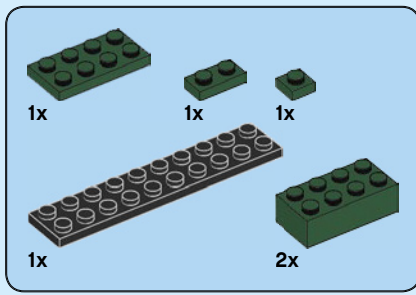

22

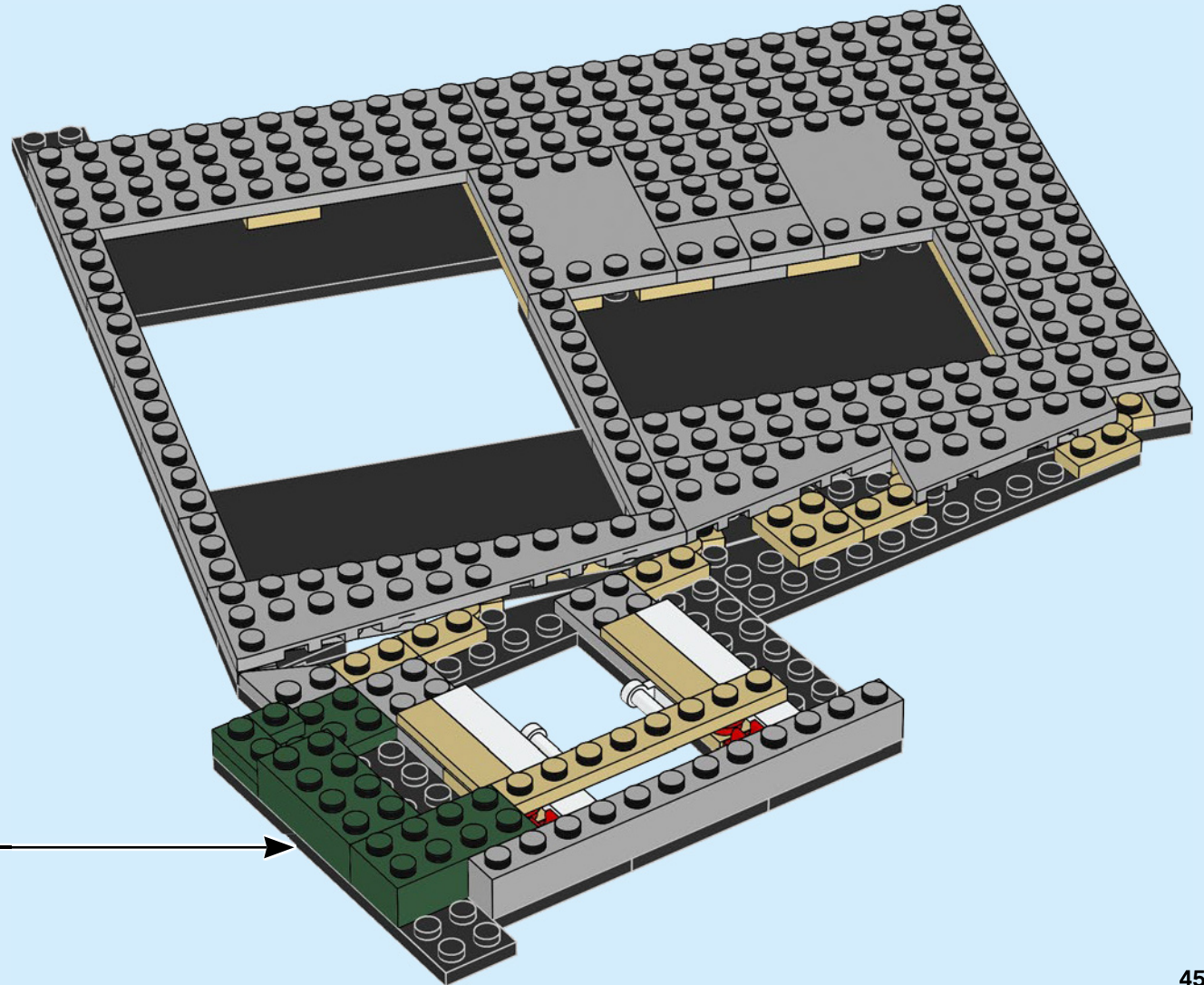
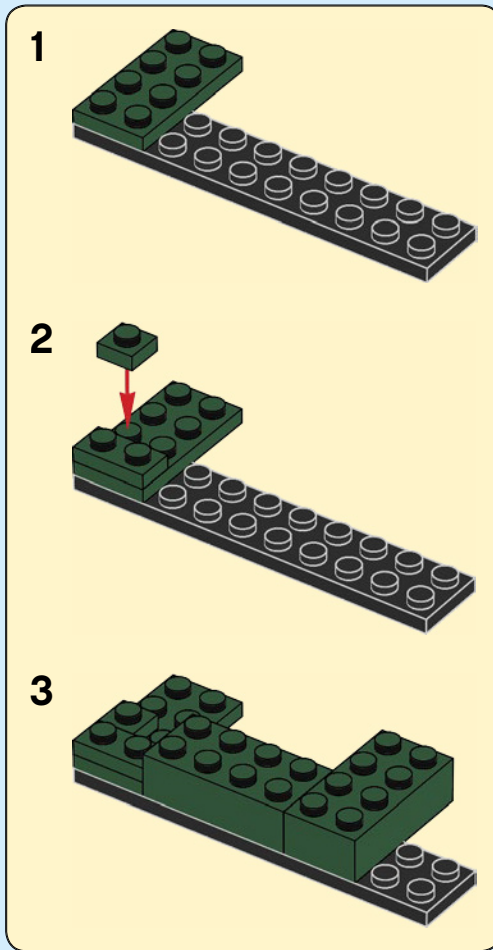

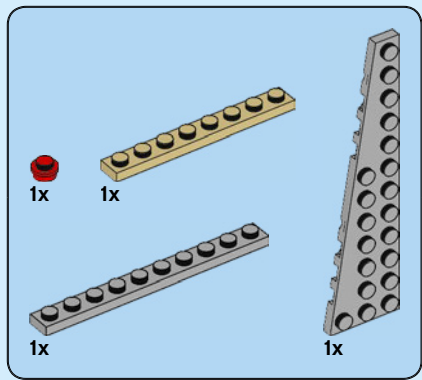

23

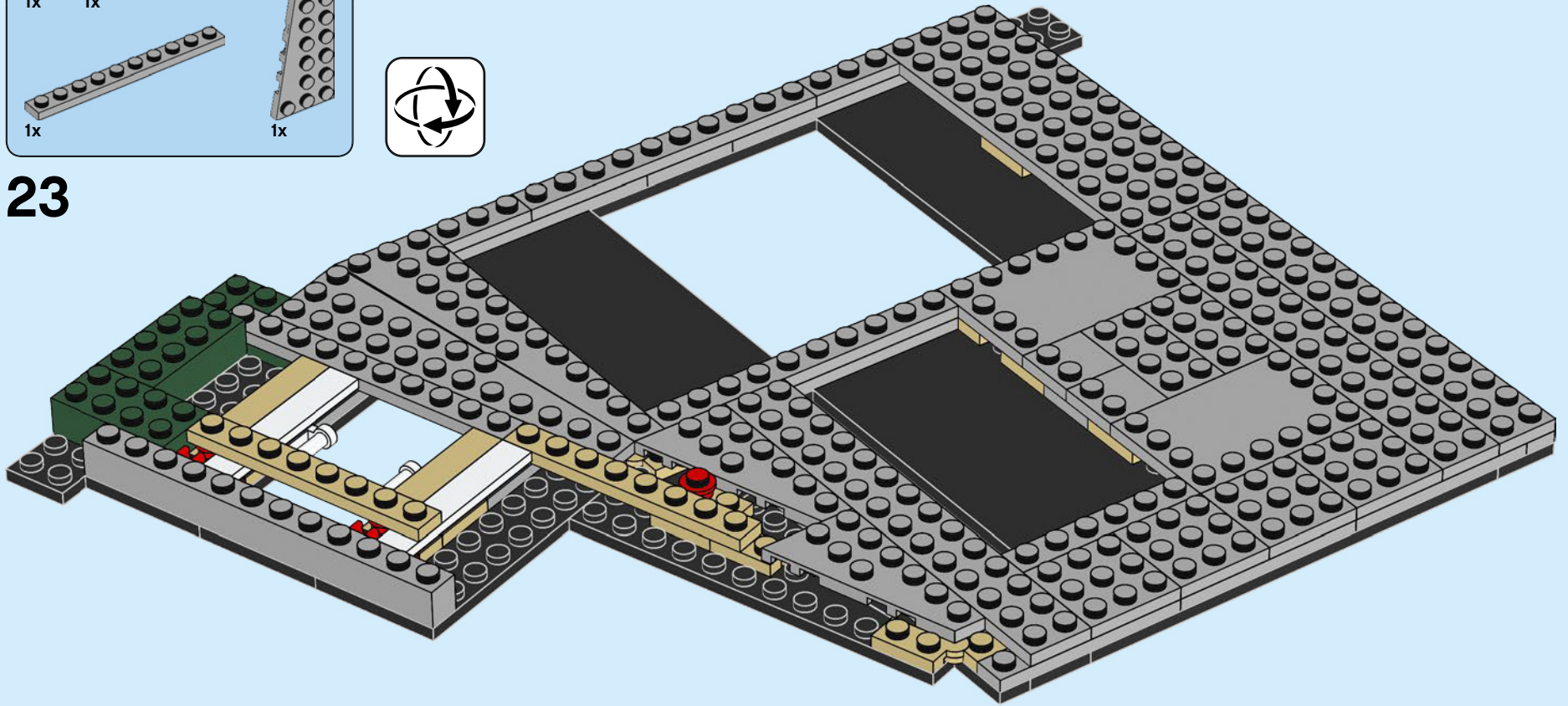

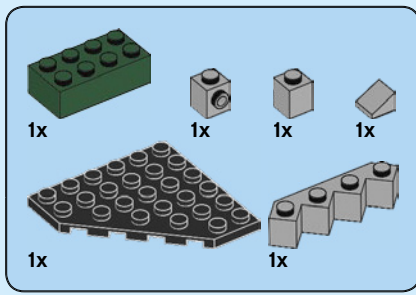

24

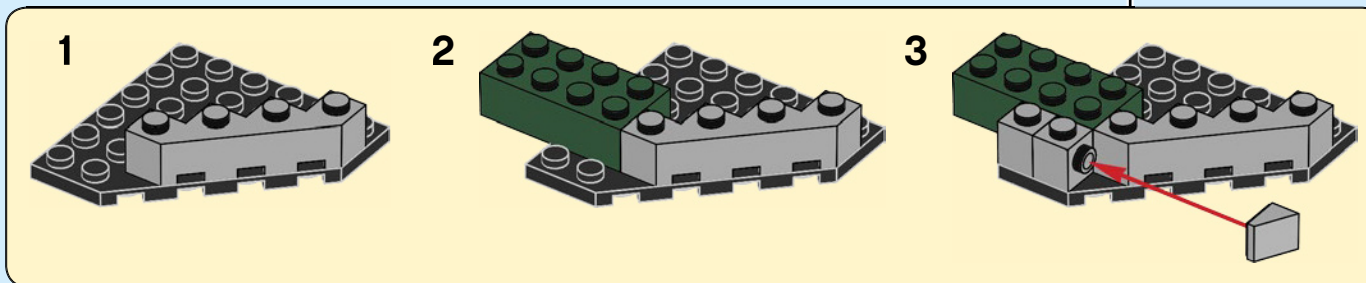
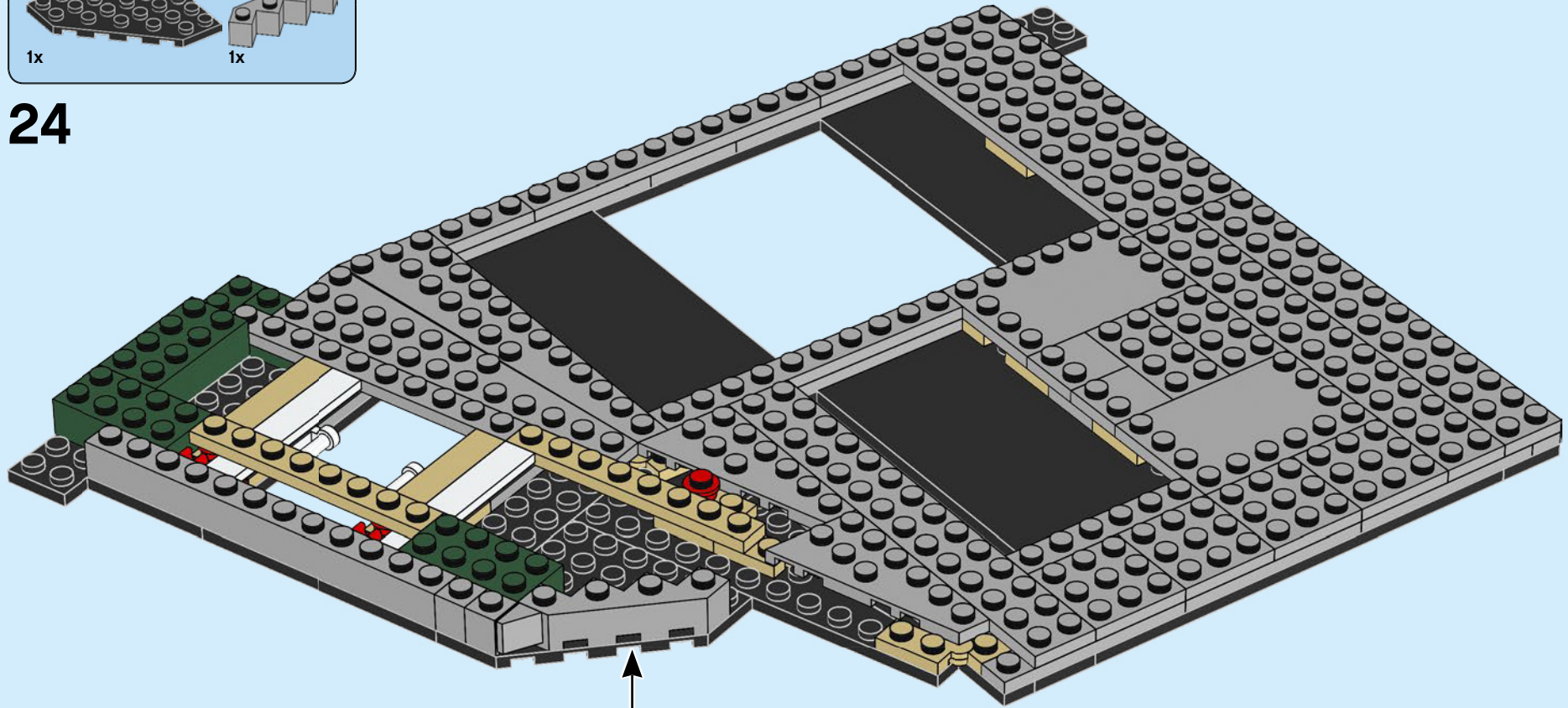

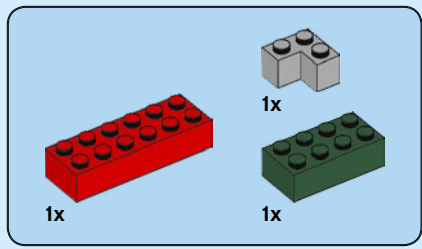

25

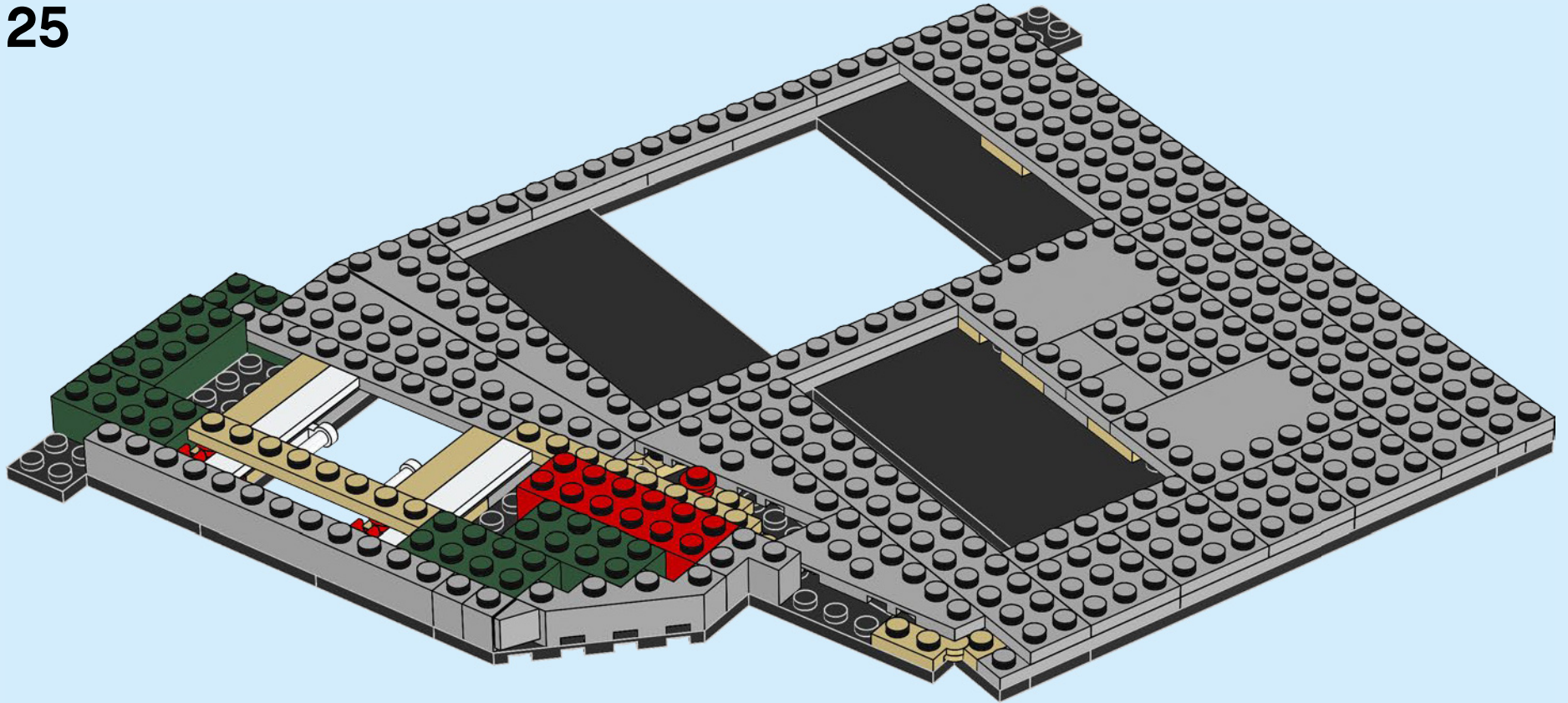

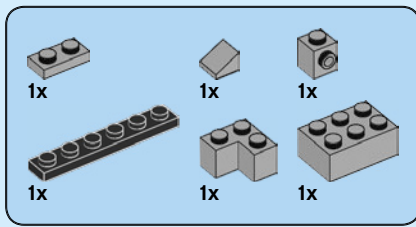

26

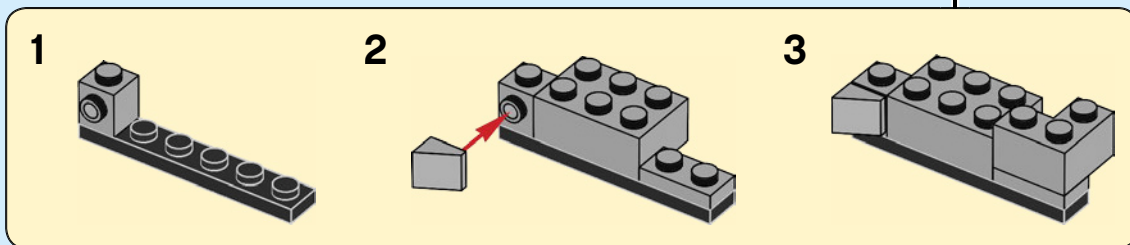
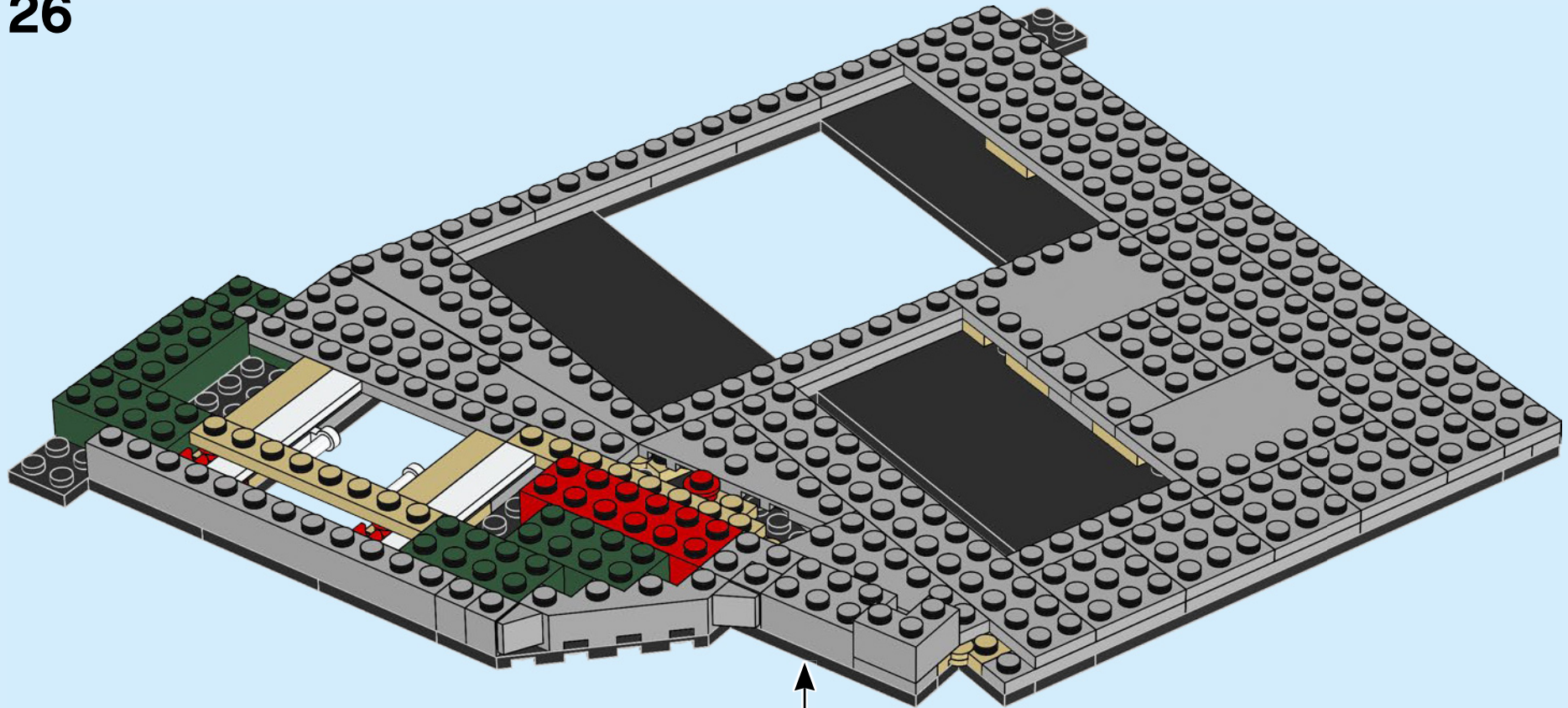

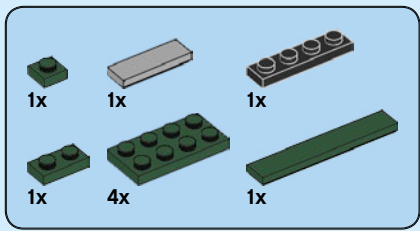

27

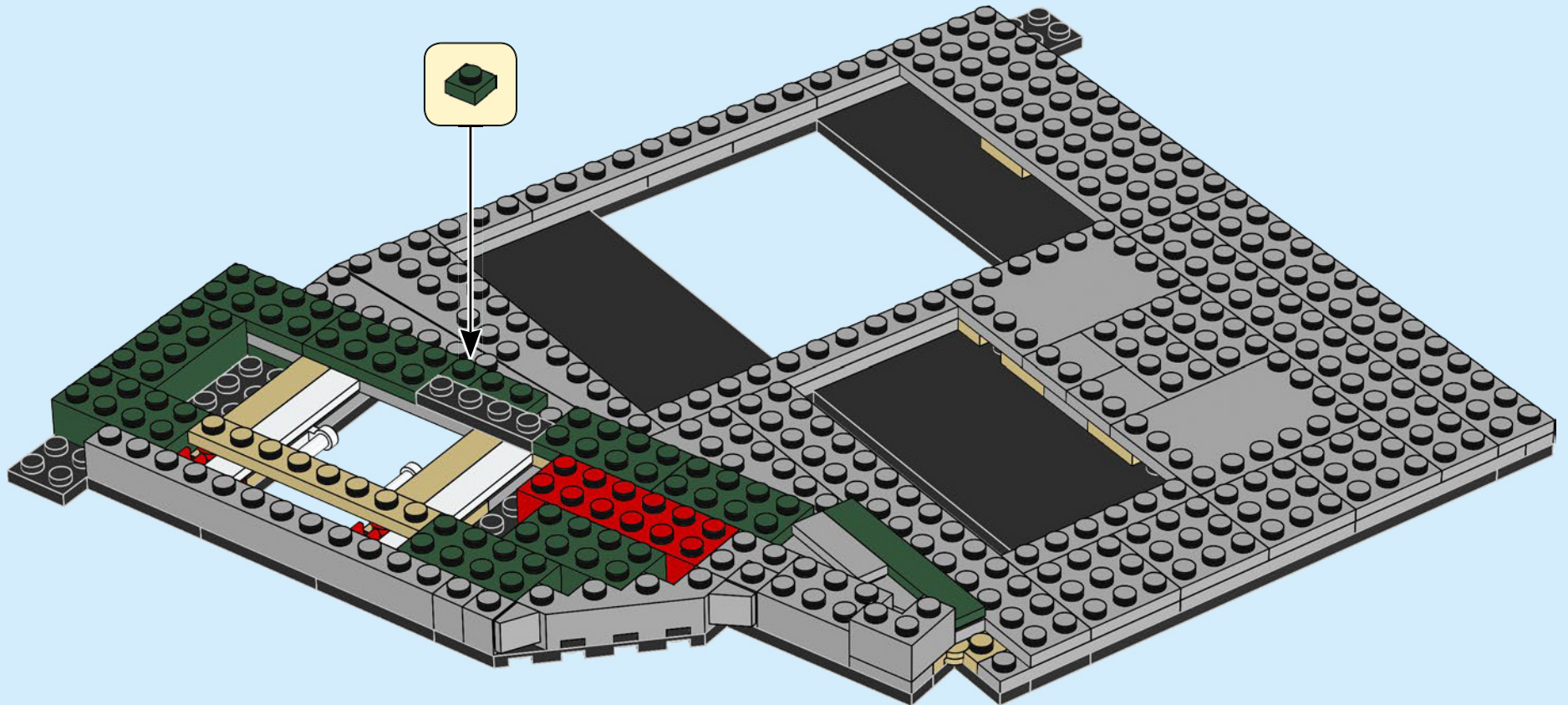

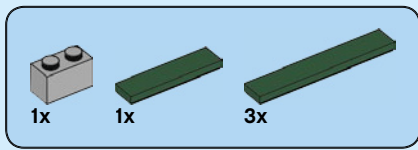

28

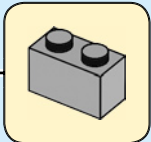
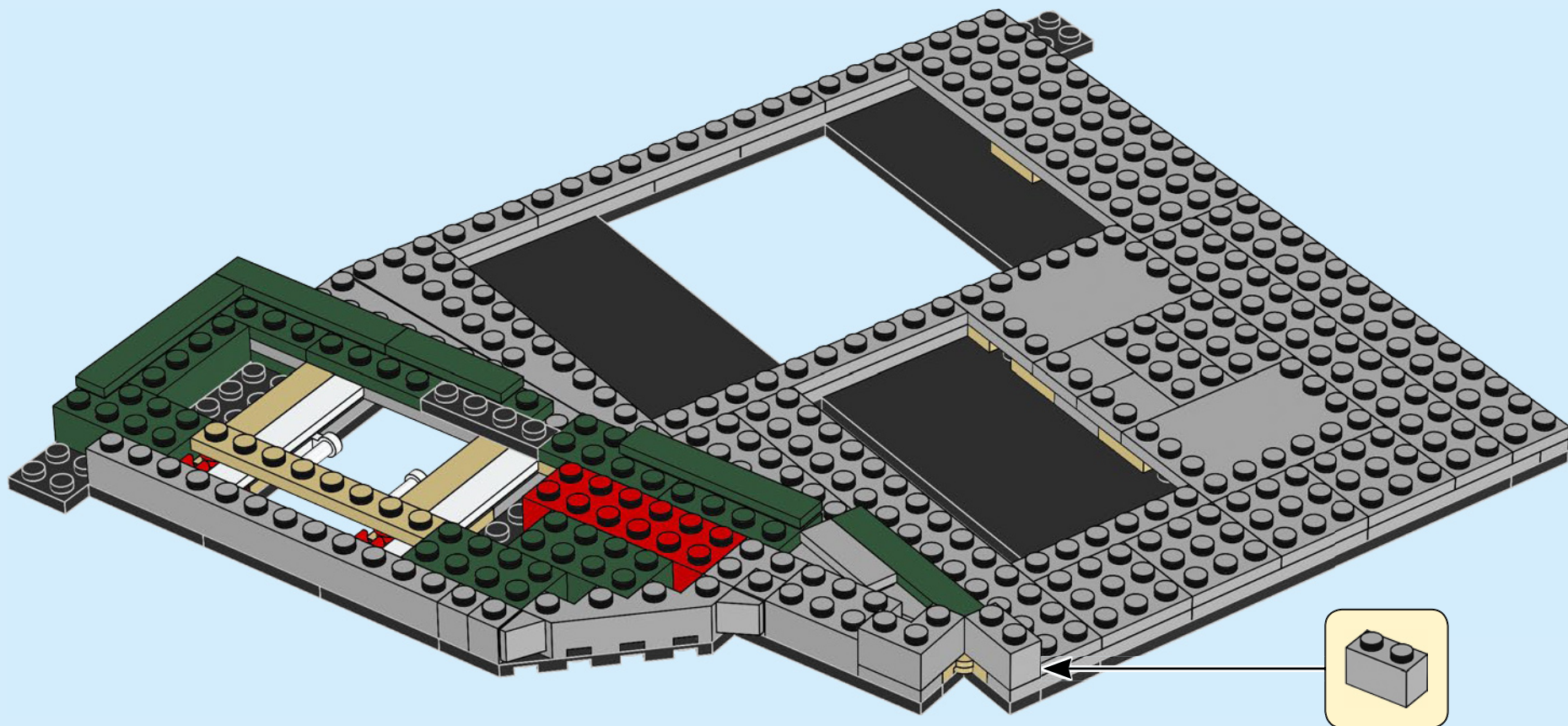

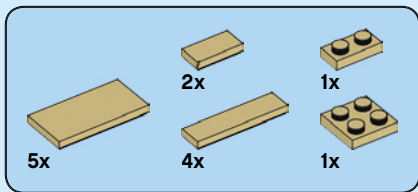

29

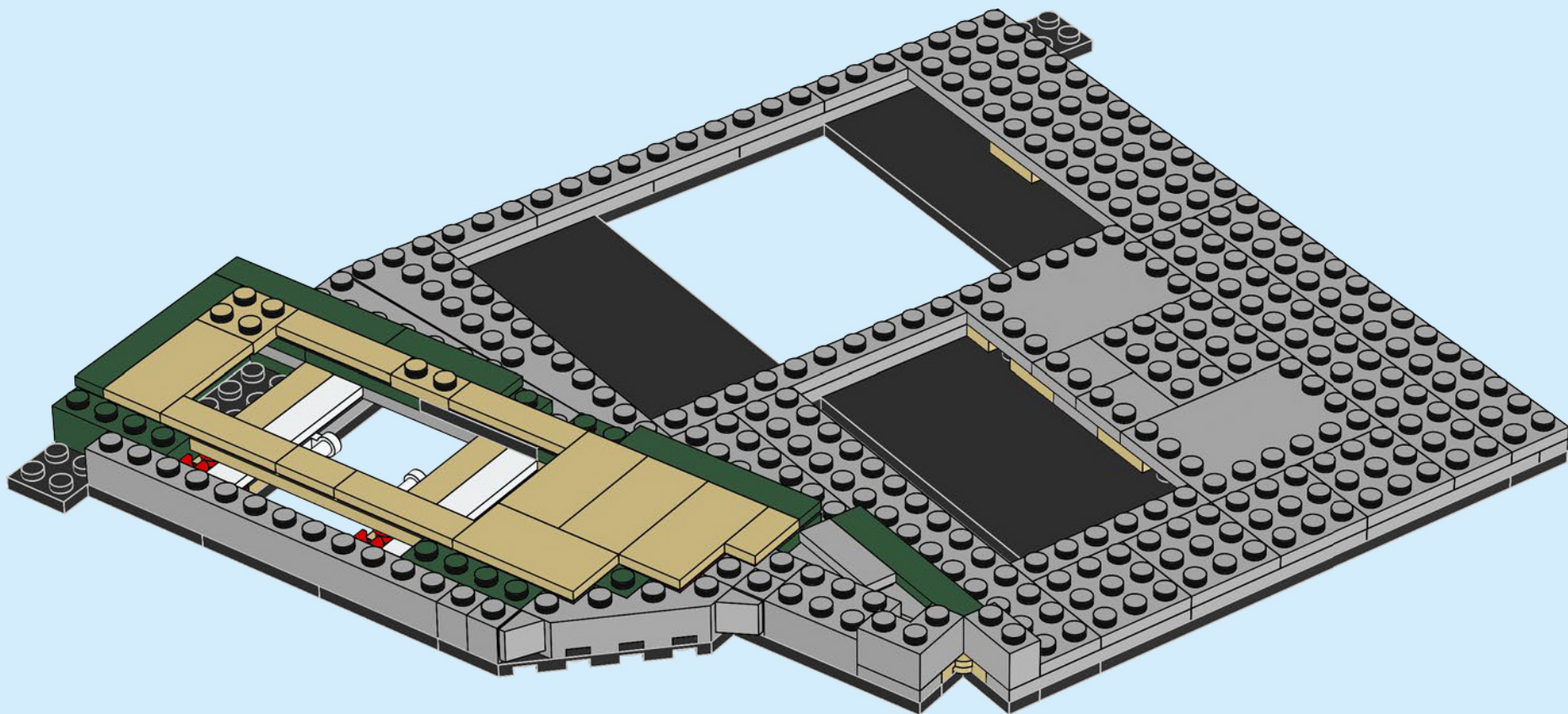

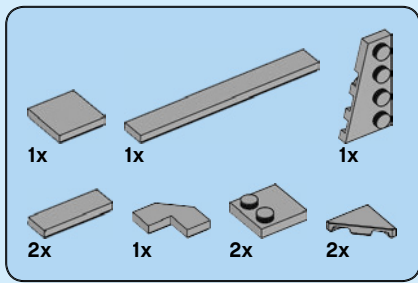

30

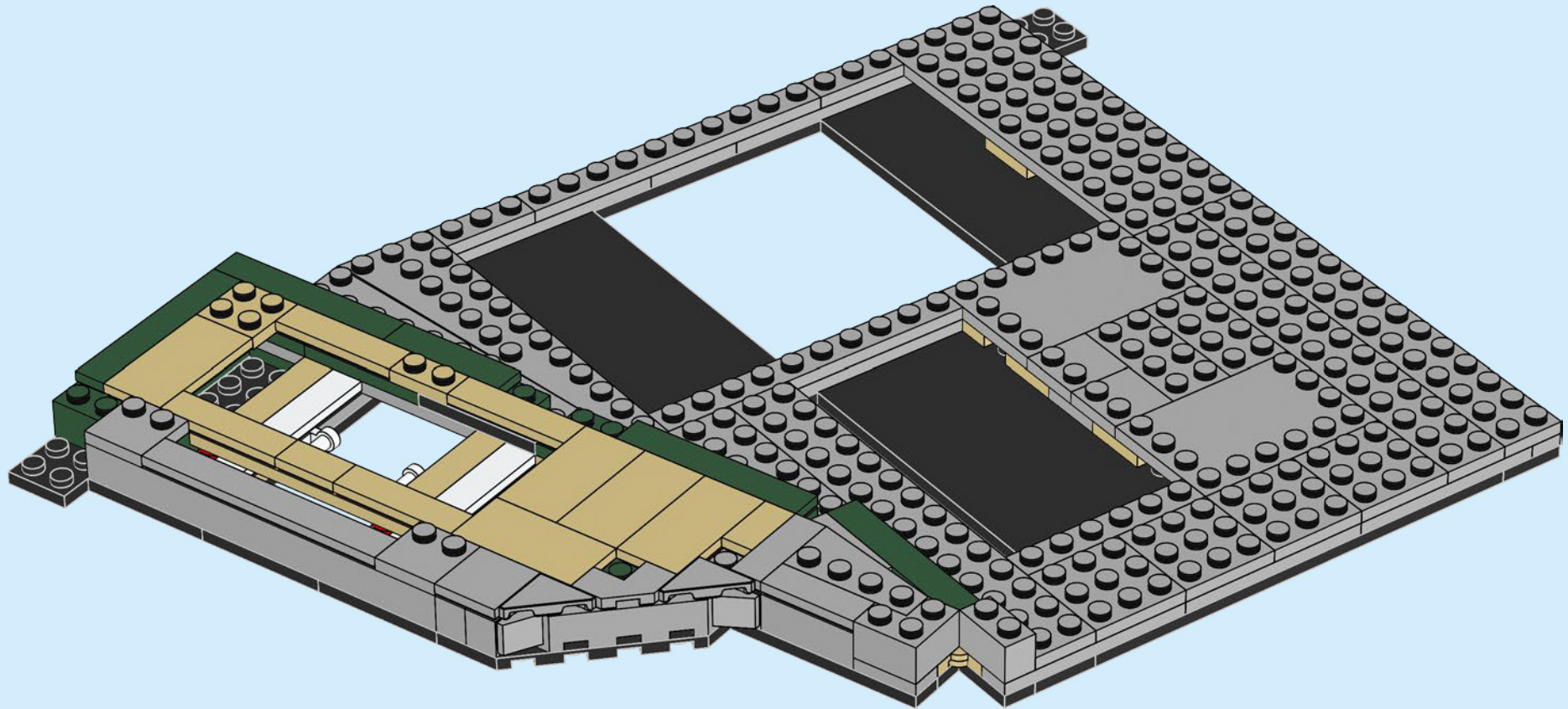

2

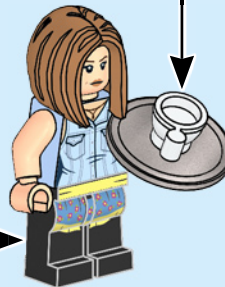
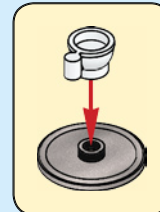
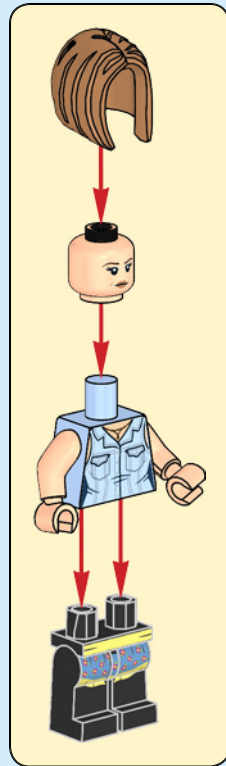
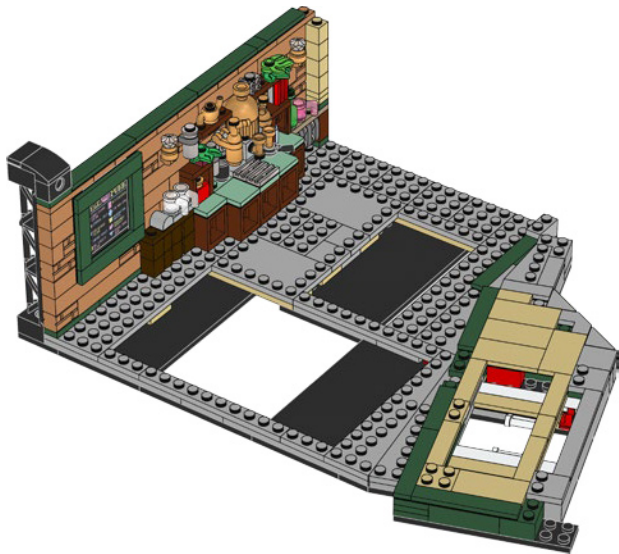
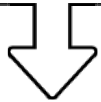

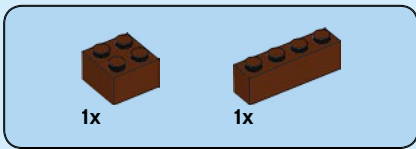

31

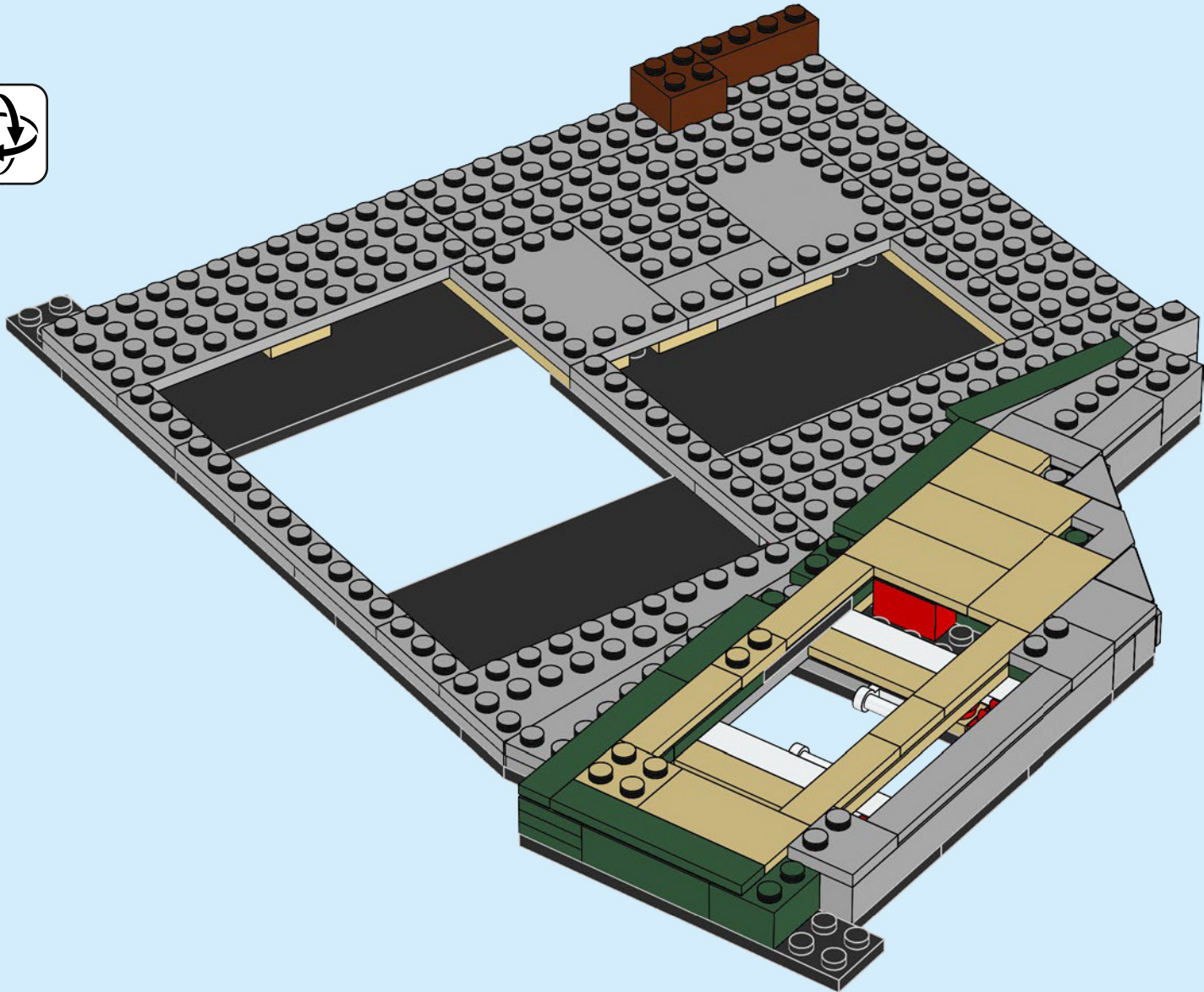

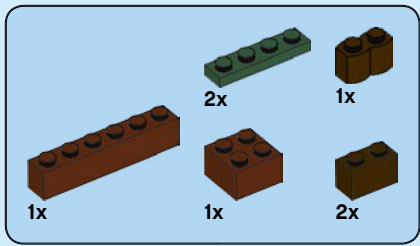

32

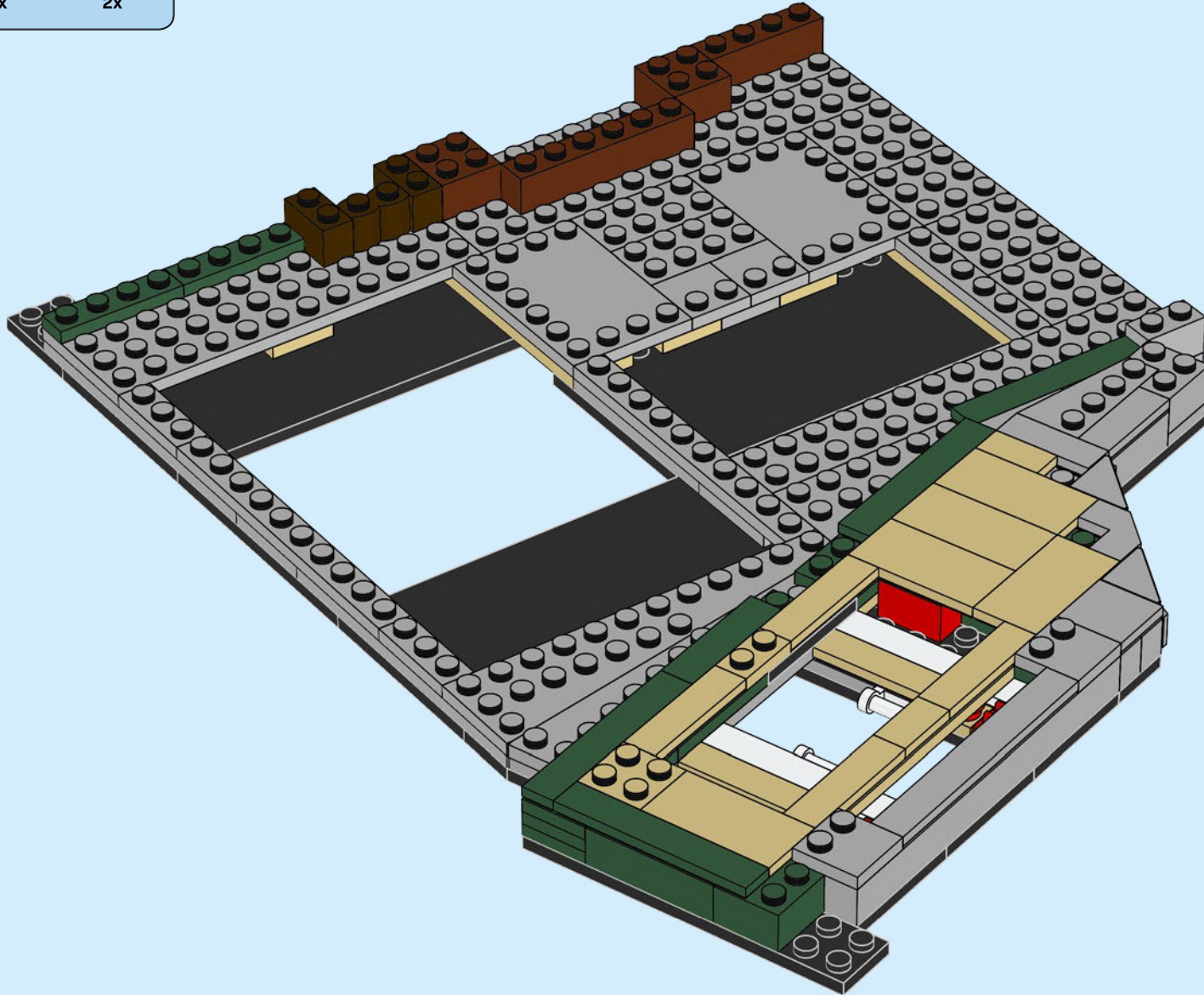

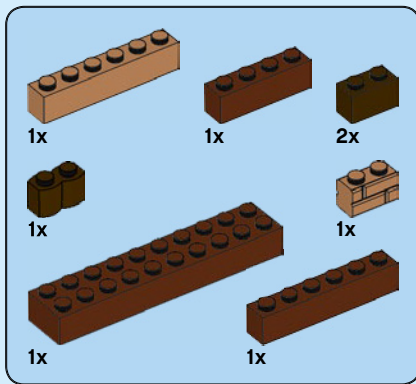

33

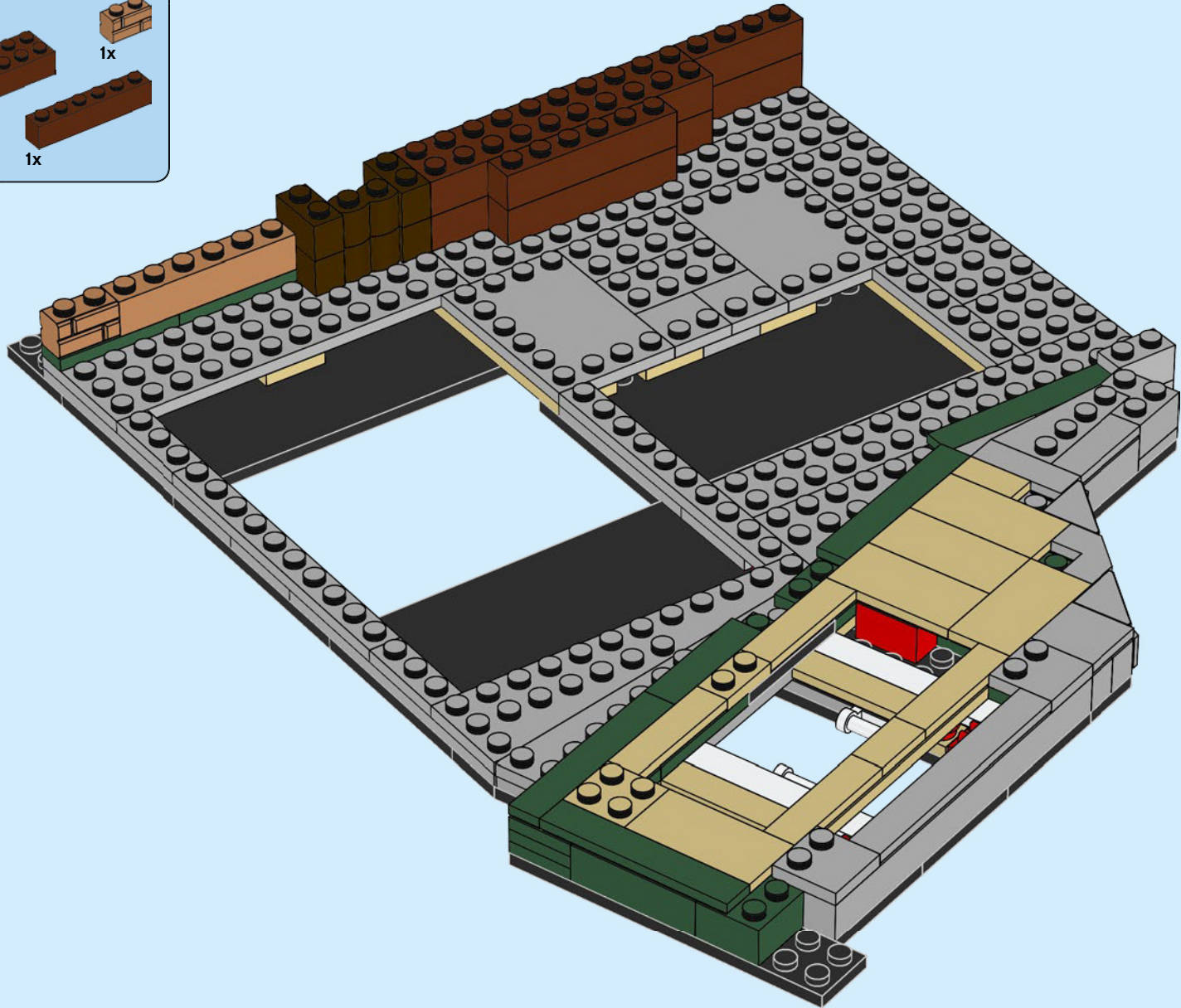

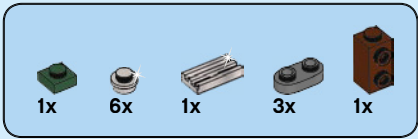

34

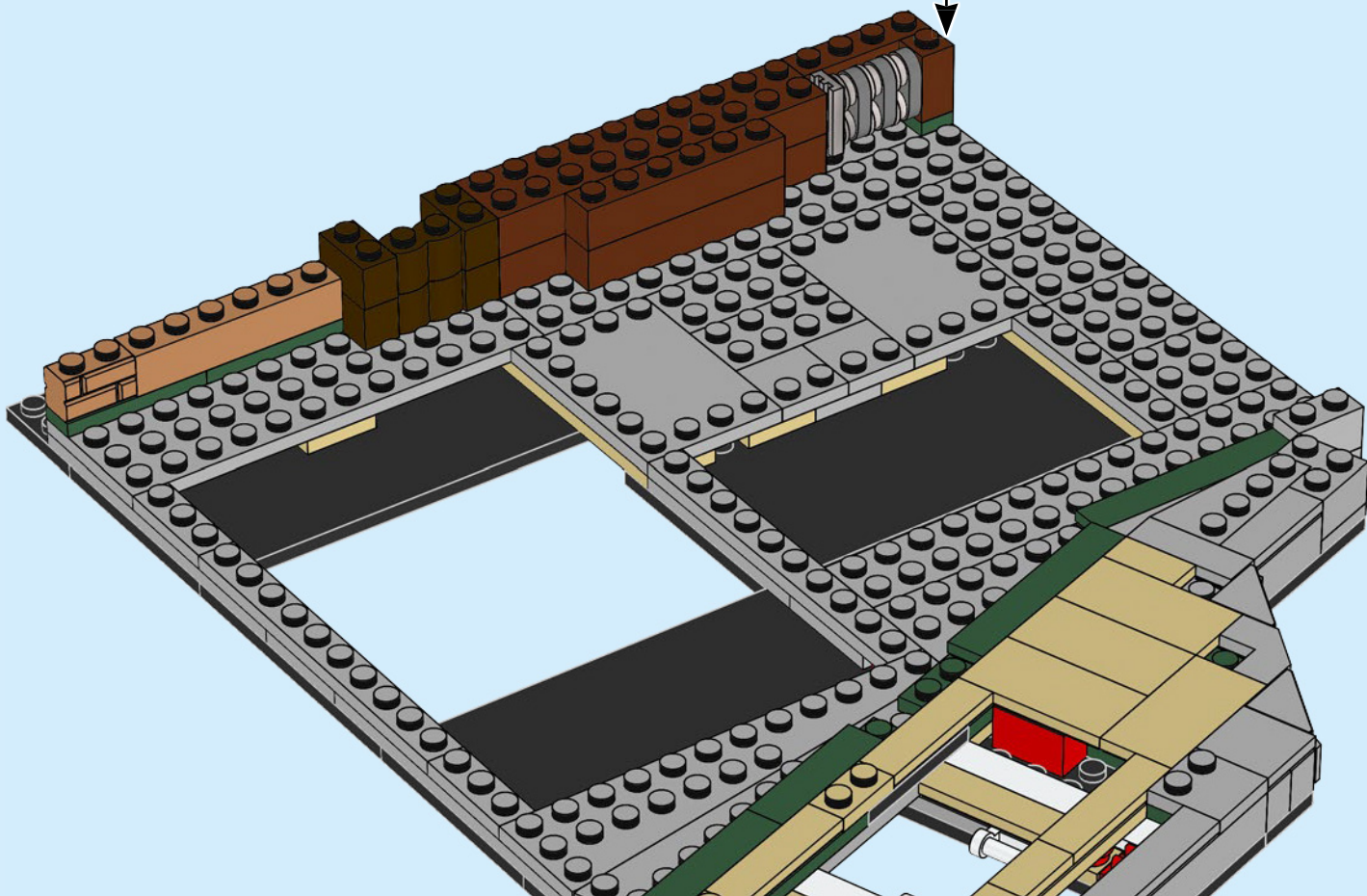
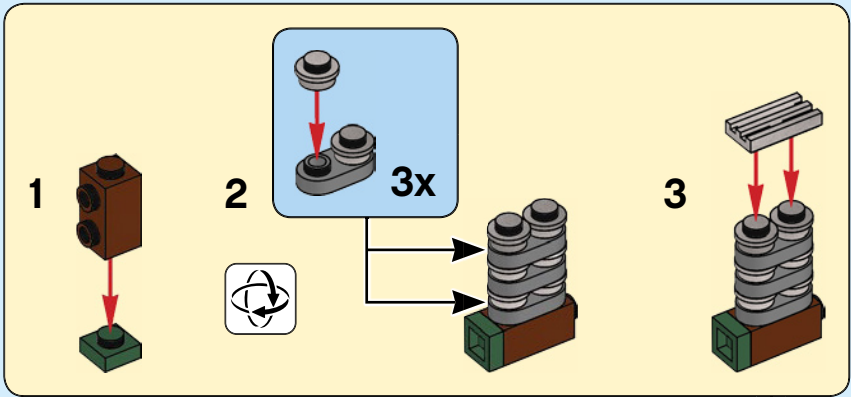

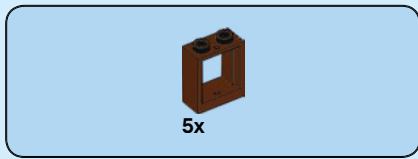

35

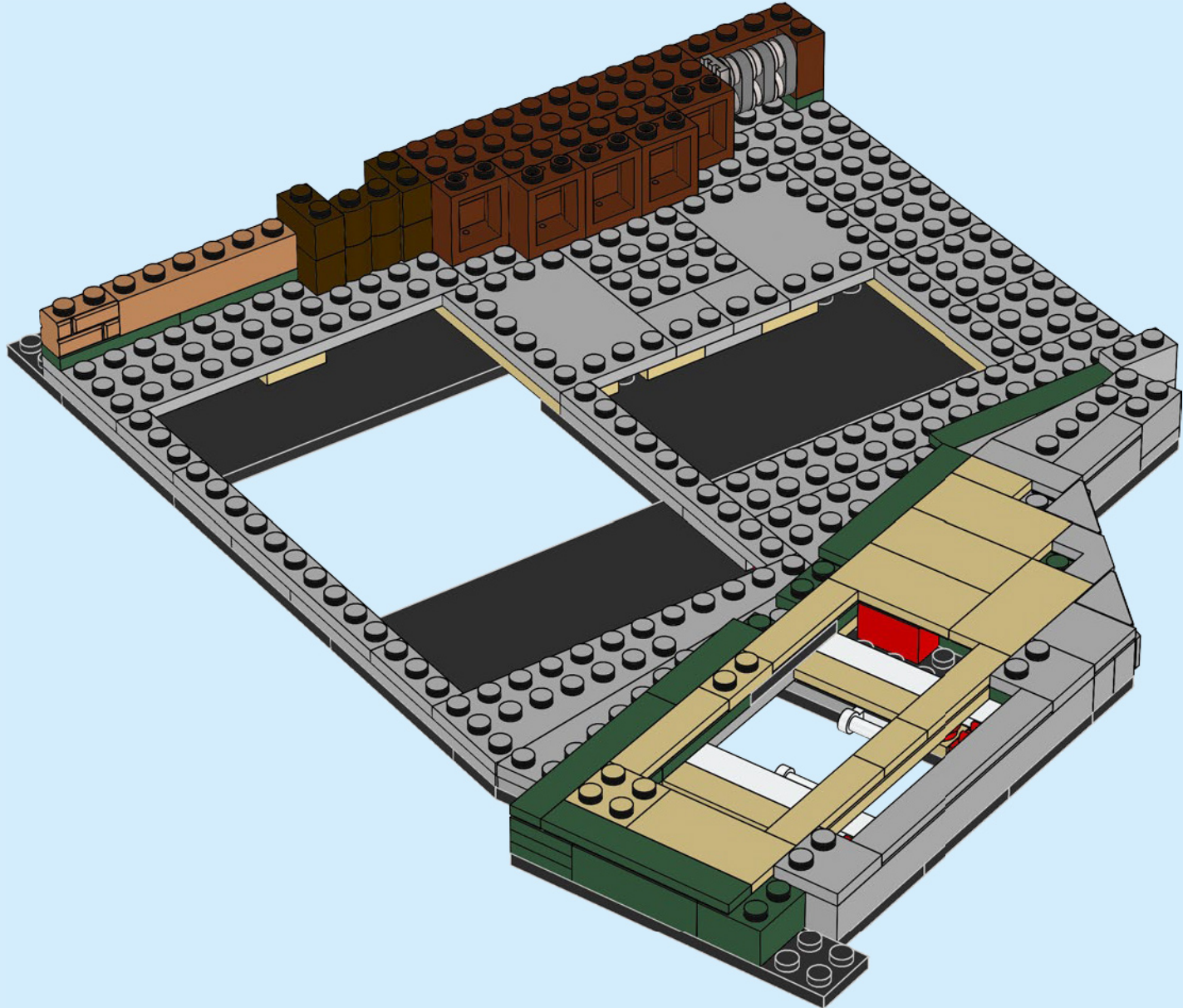

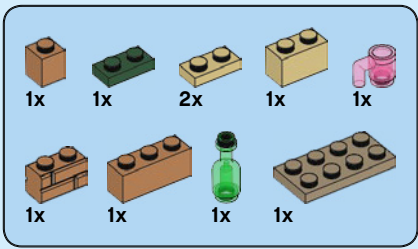

36

1

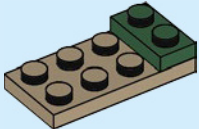

2

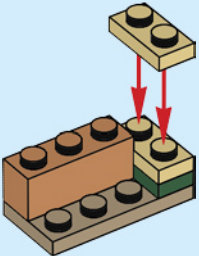

3

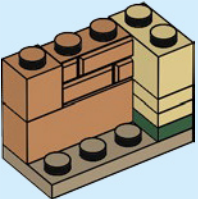

4

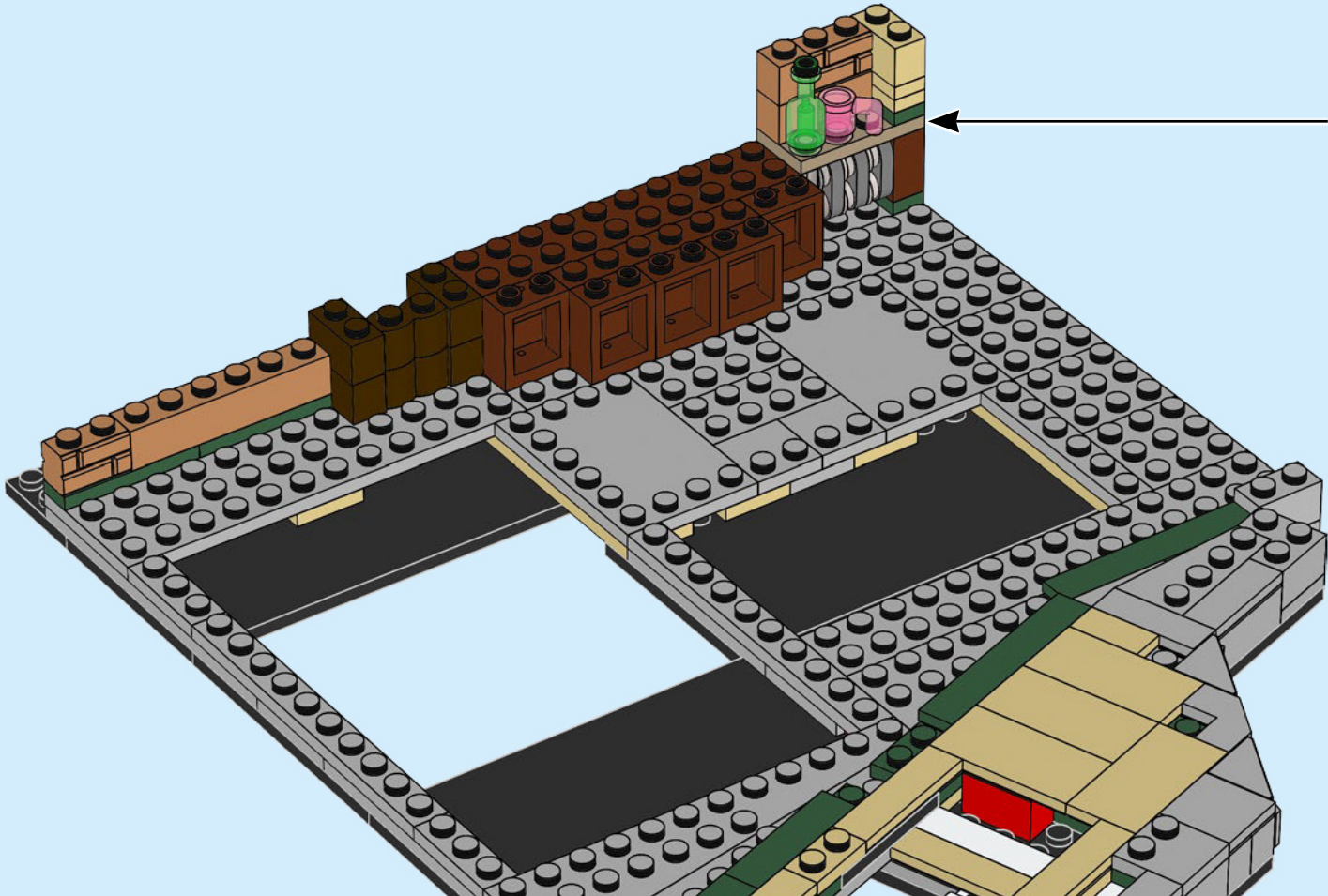
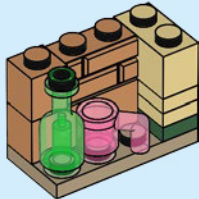

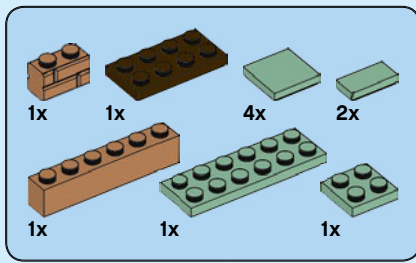

37

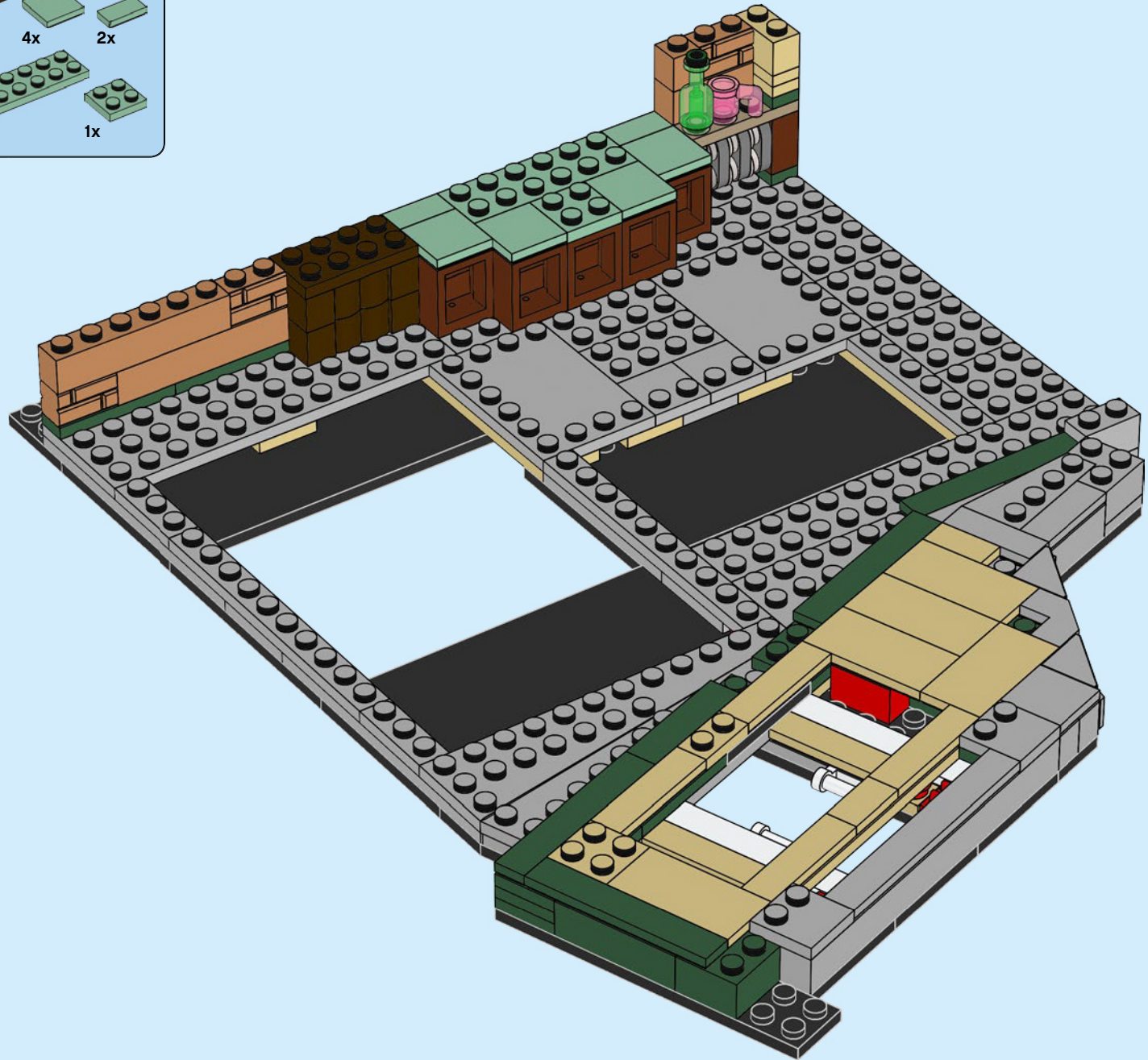

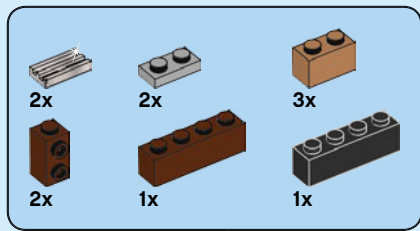

38

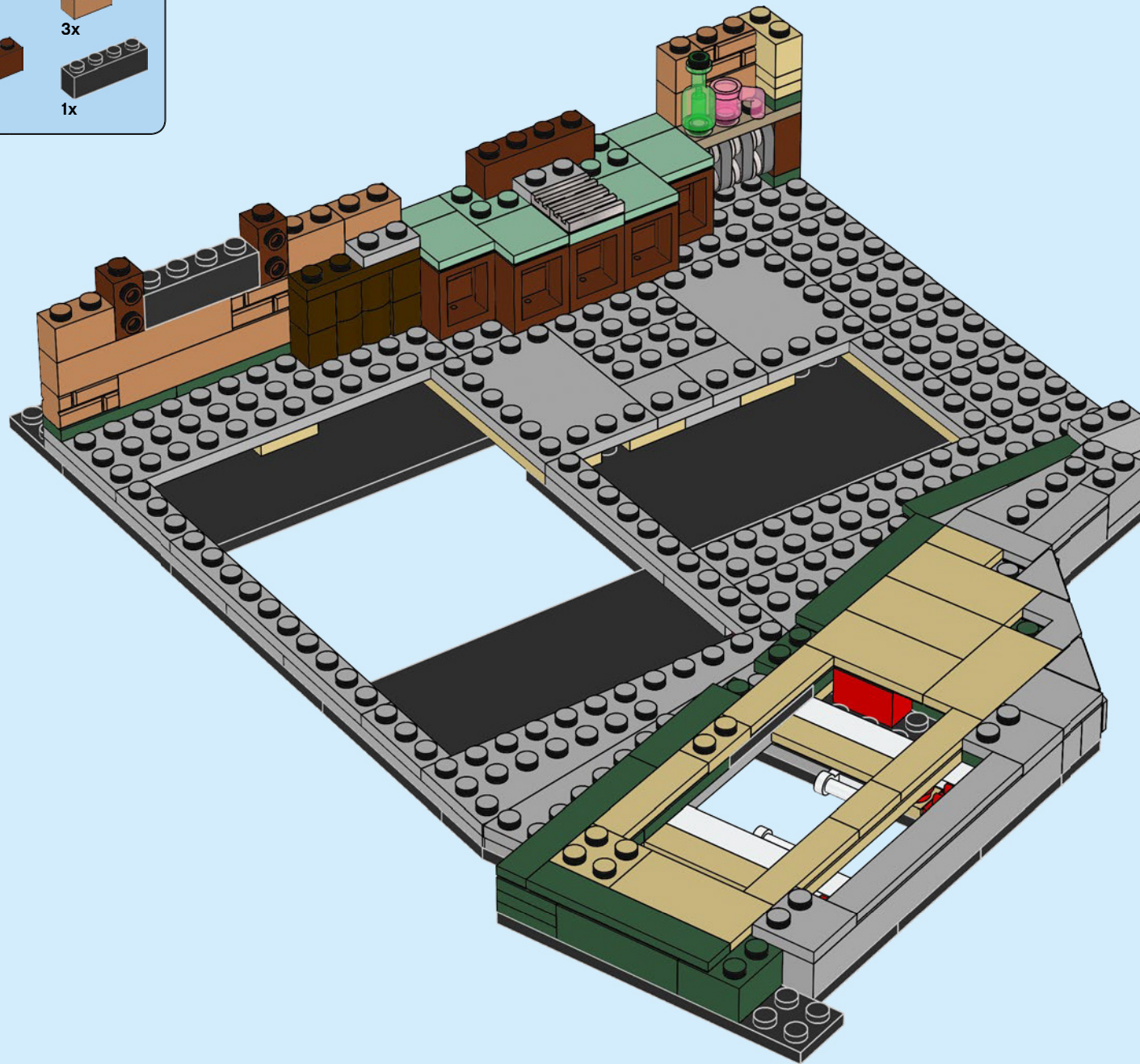

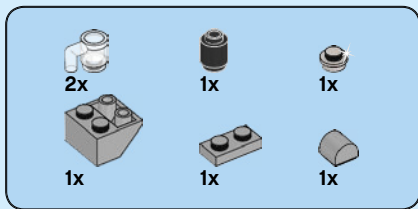

39

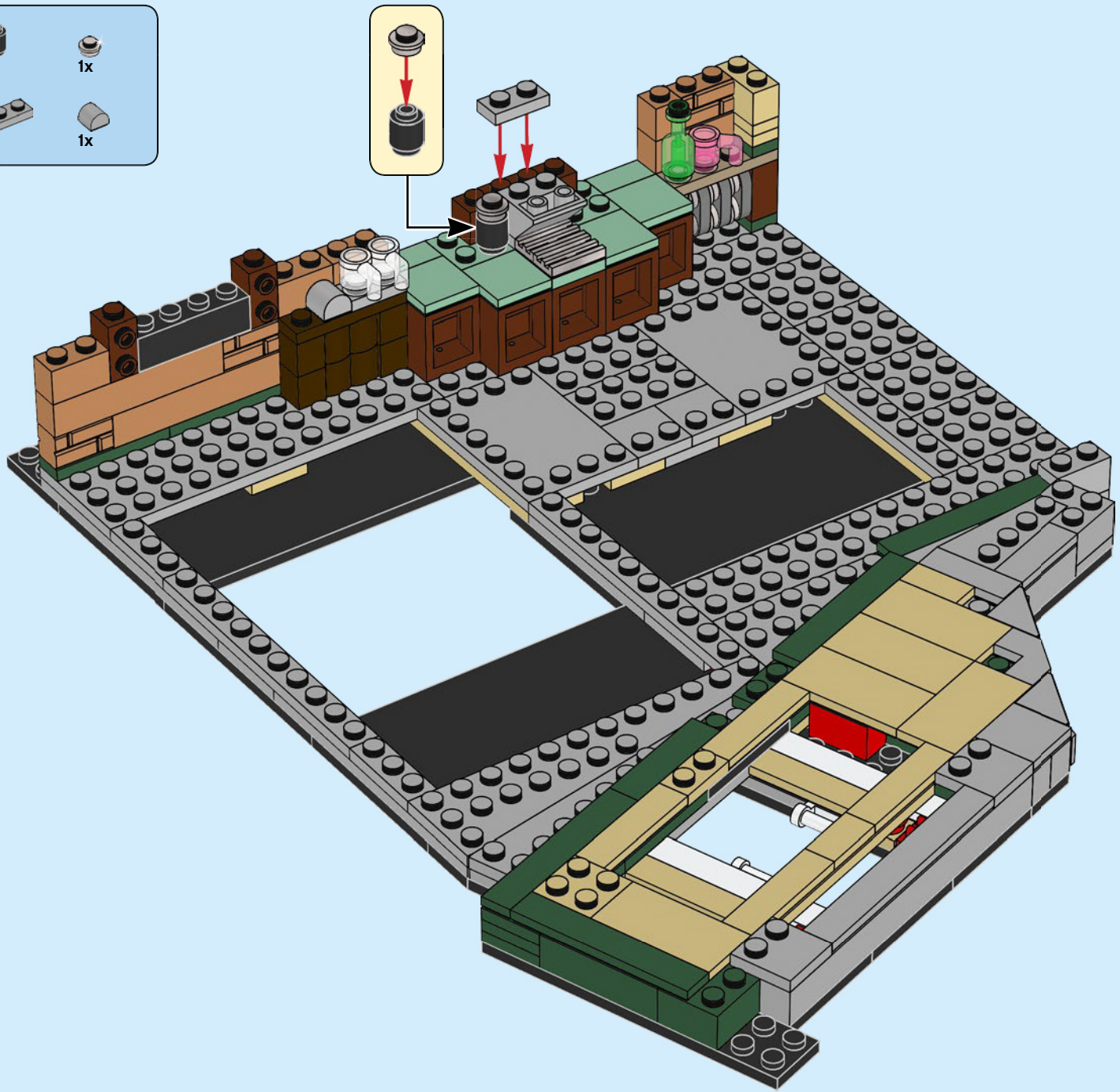

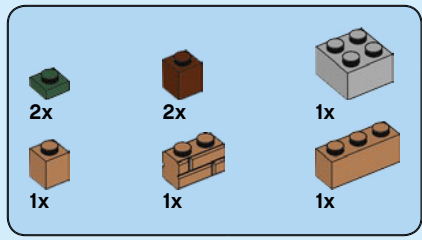

40

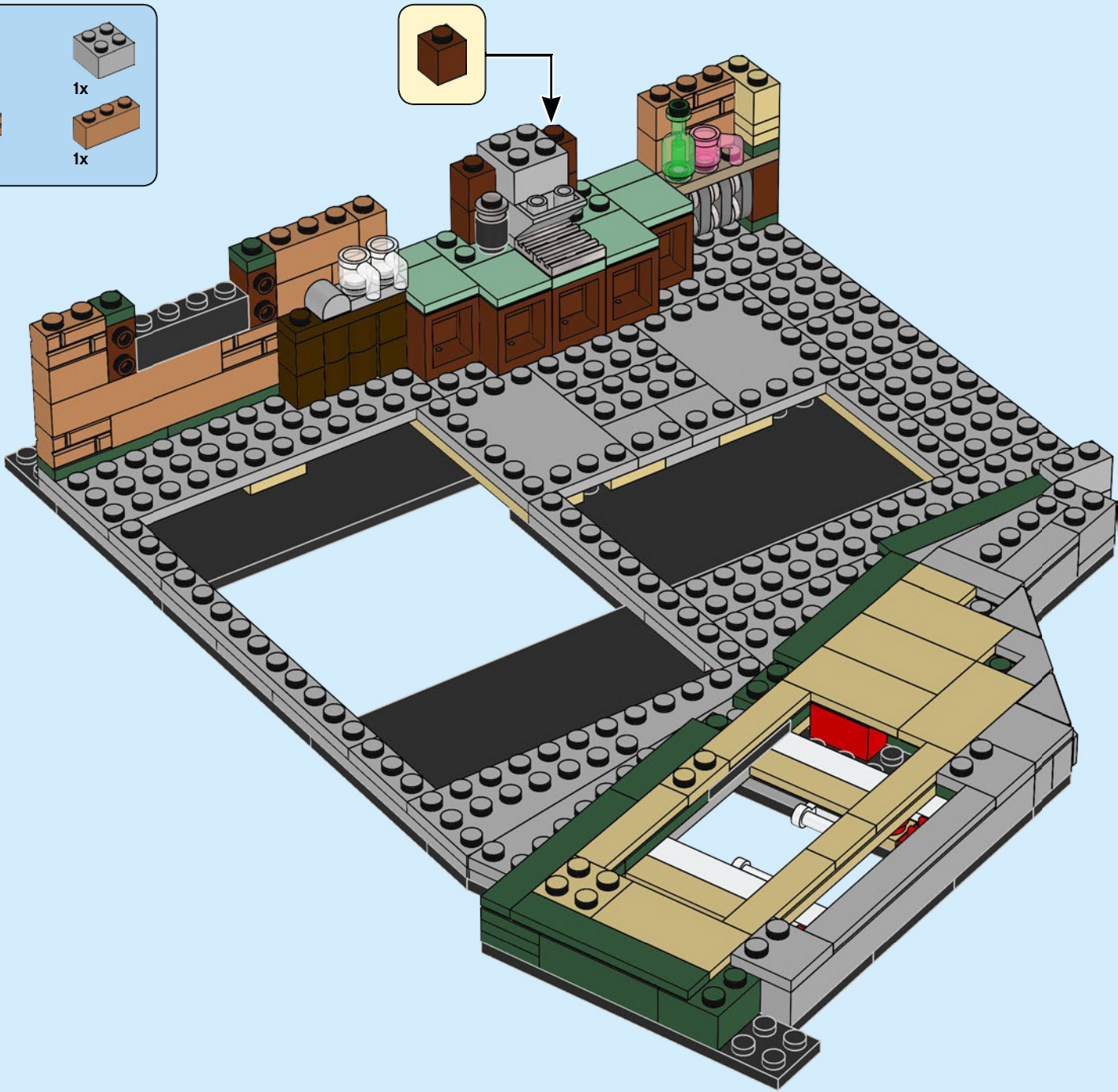



41

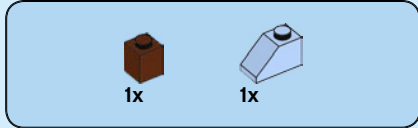

42

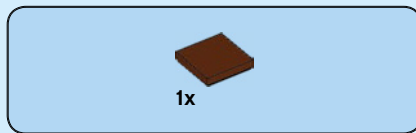

43

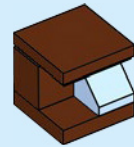

44

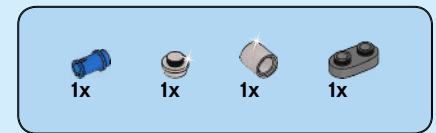
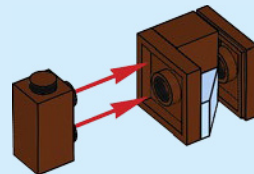
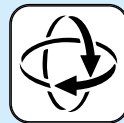

45

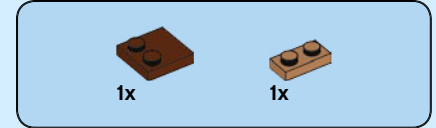
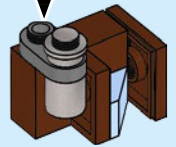
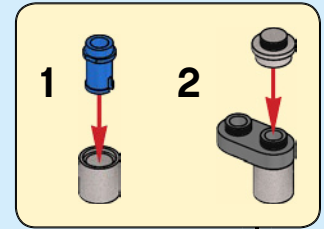

46

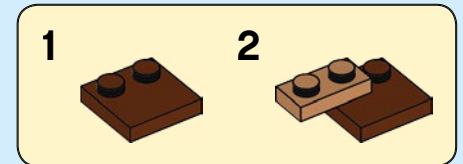

47

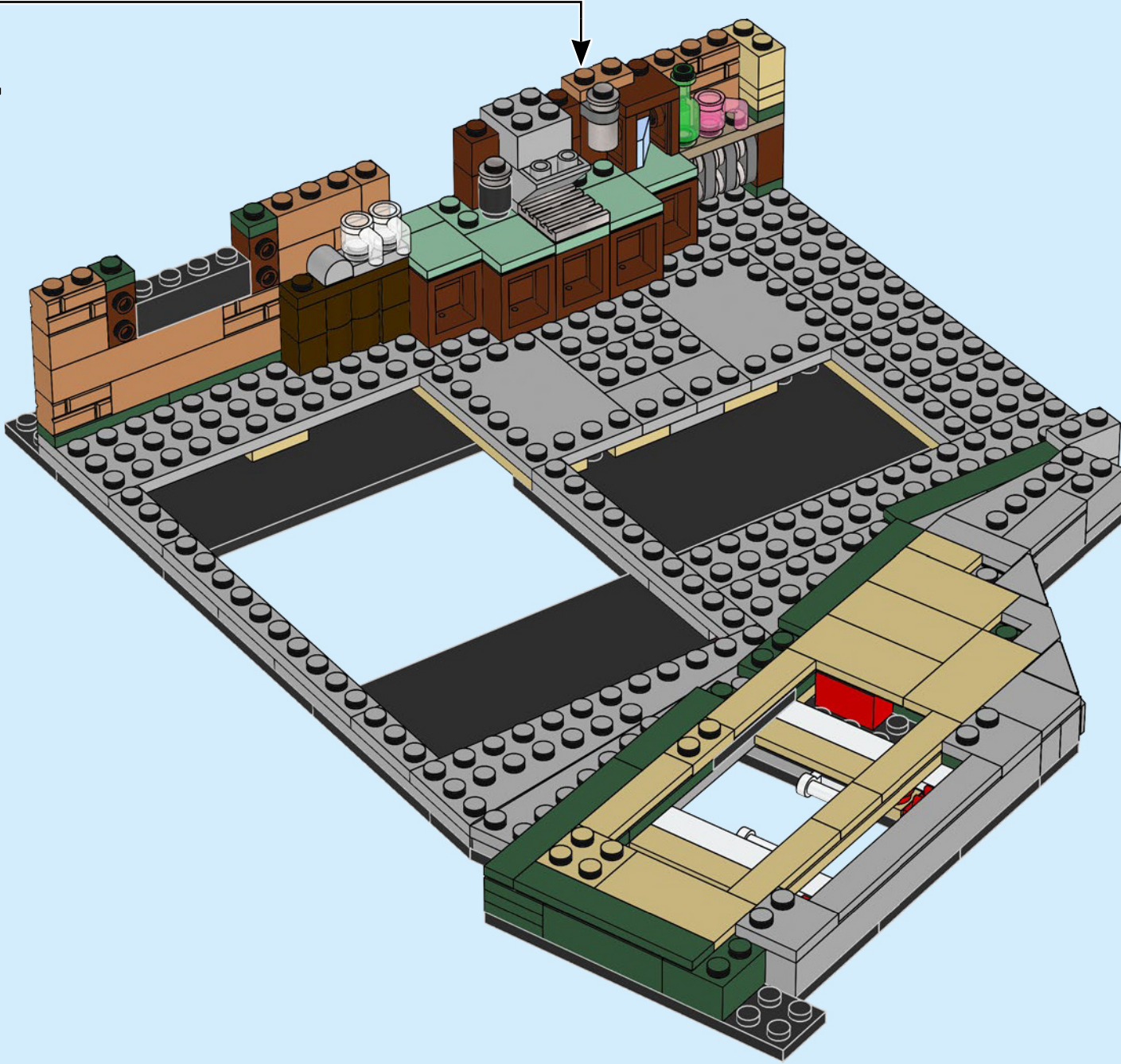



48

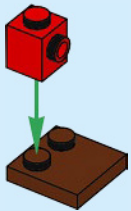

49

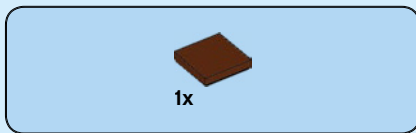
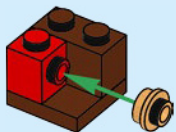

50

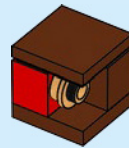

51

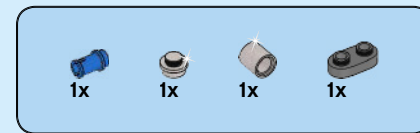
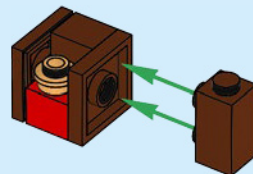

52

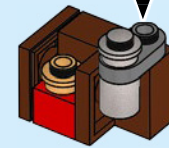
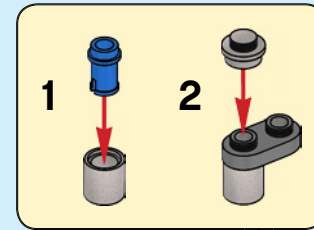

53

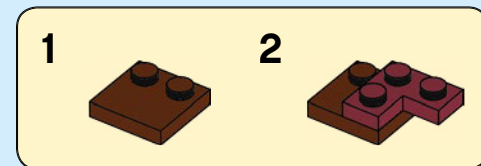

54

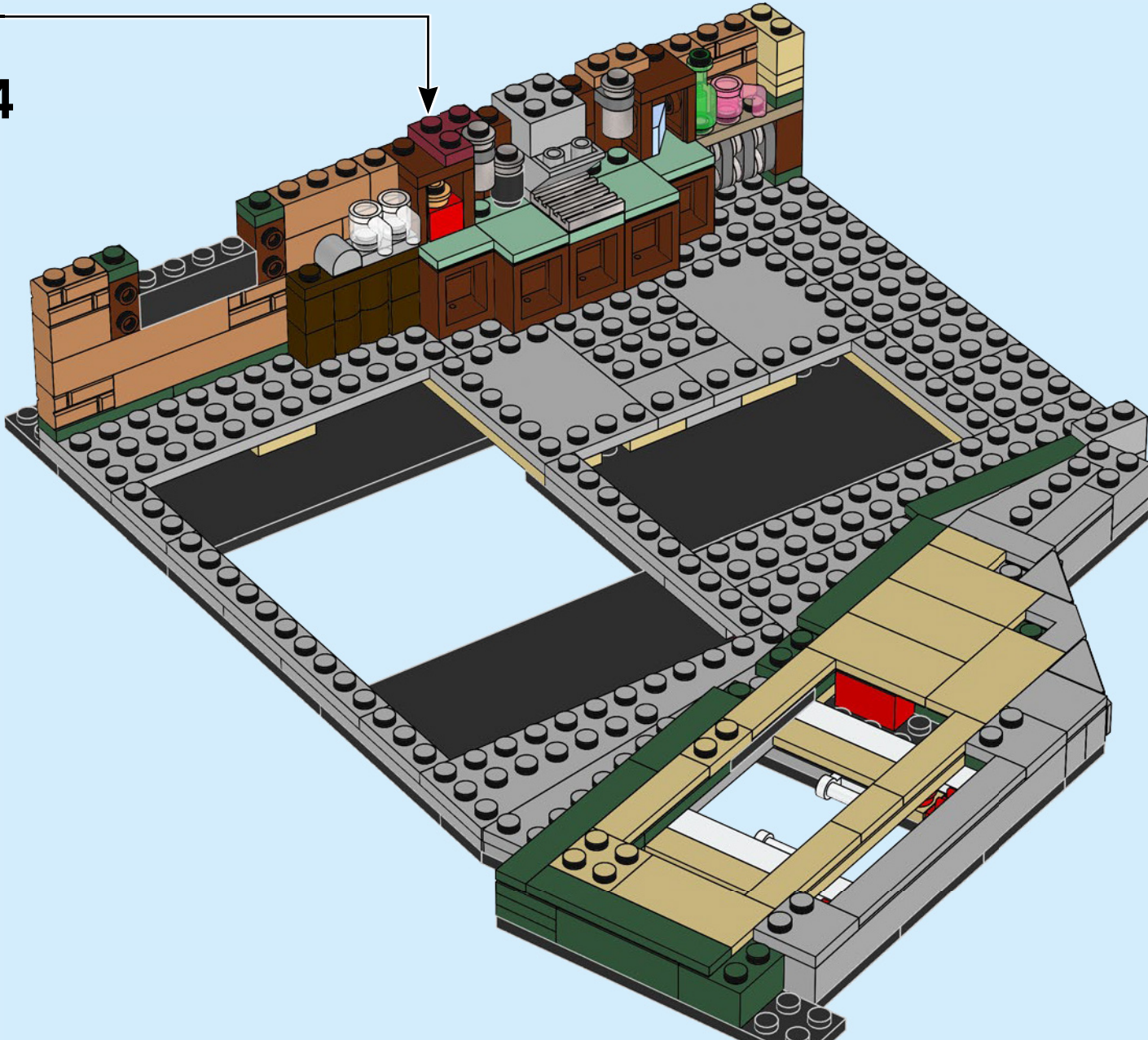

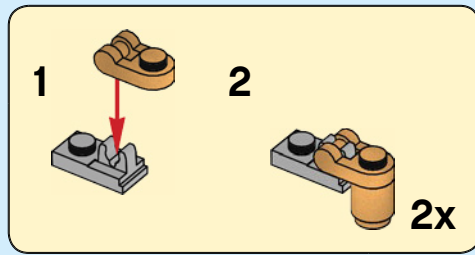
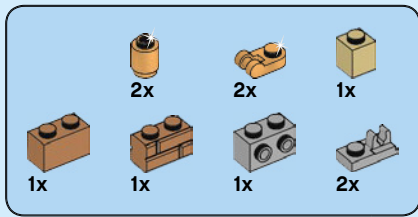

55

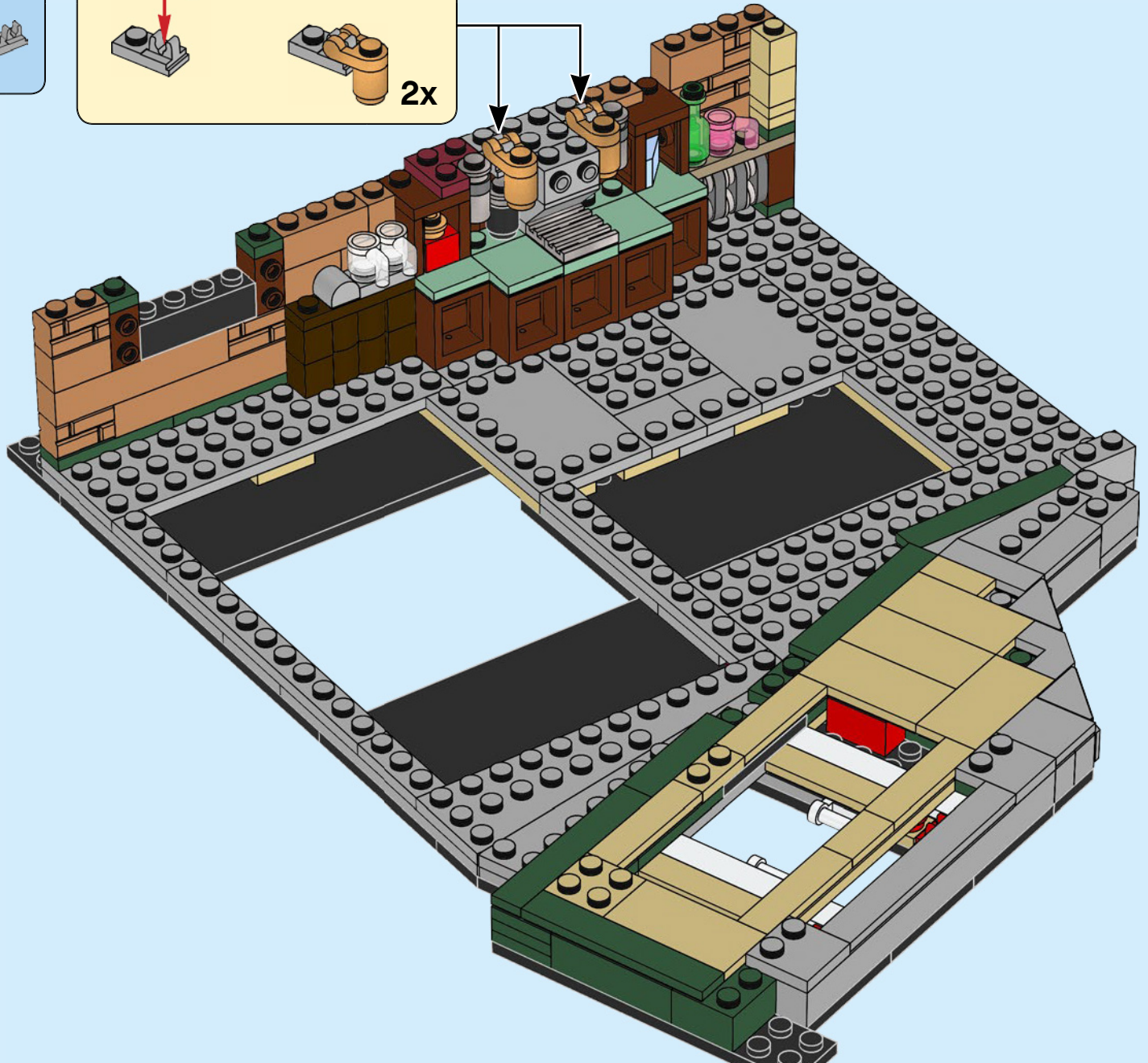

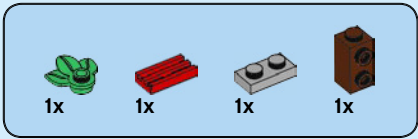

56

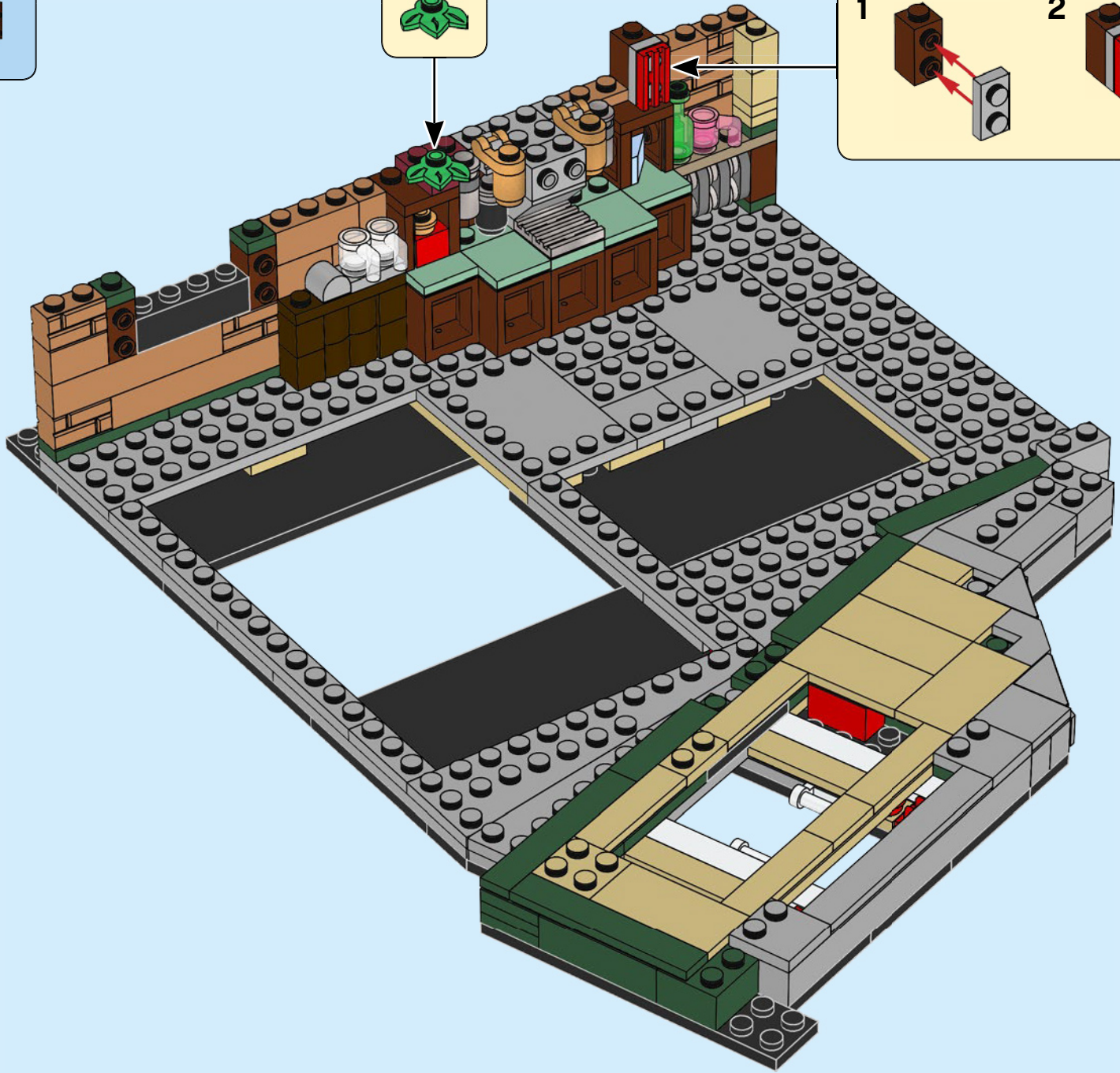
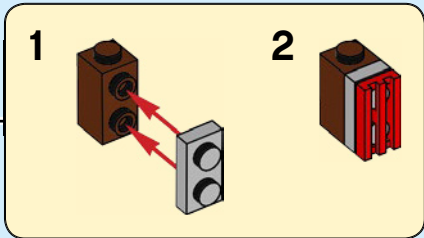

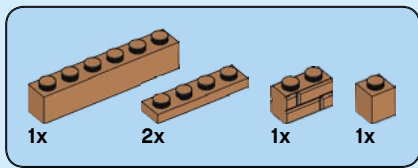

57

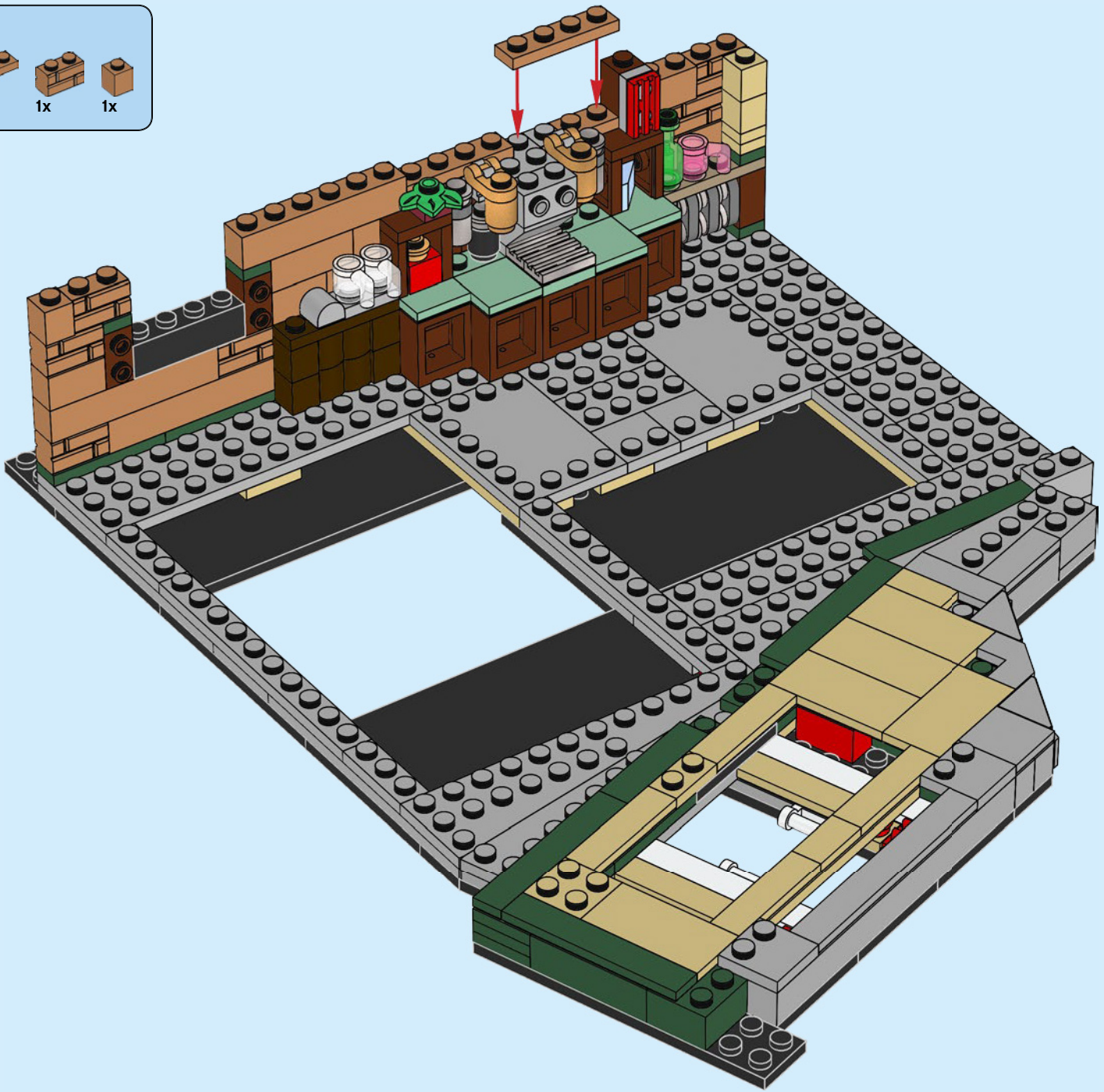

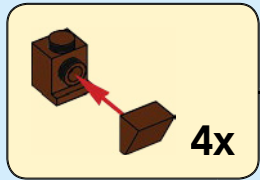
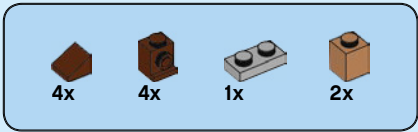

58

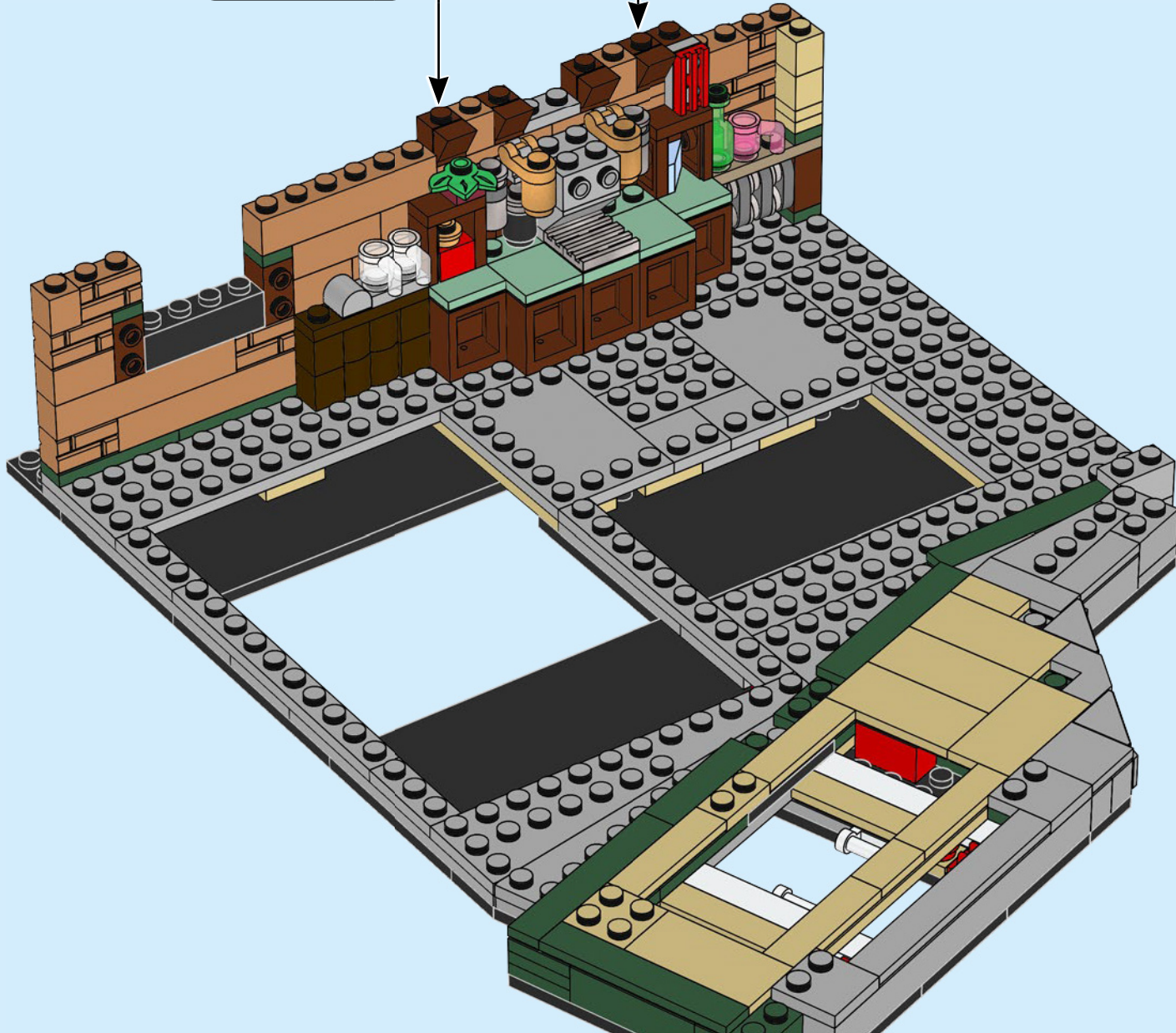

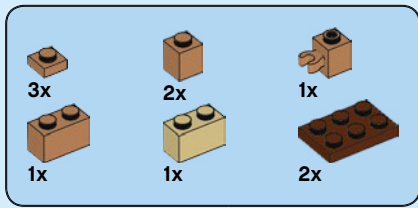

59

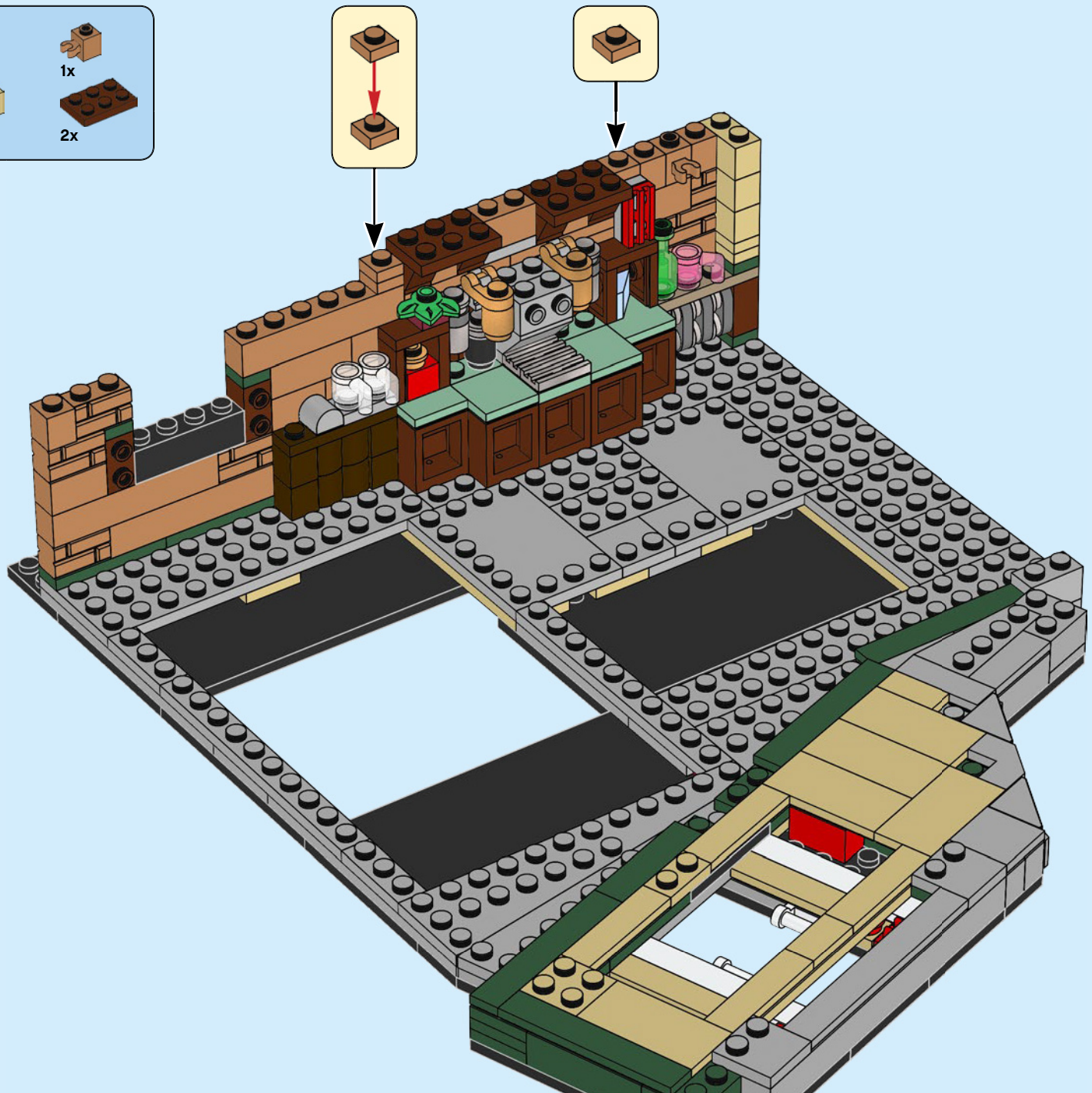

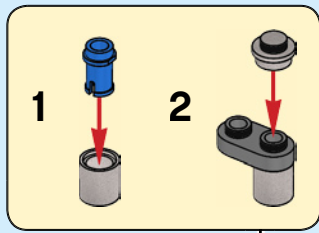
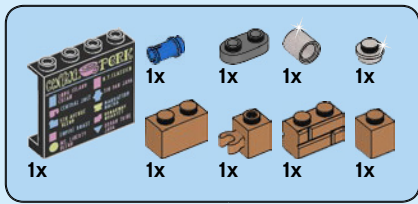

60

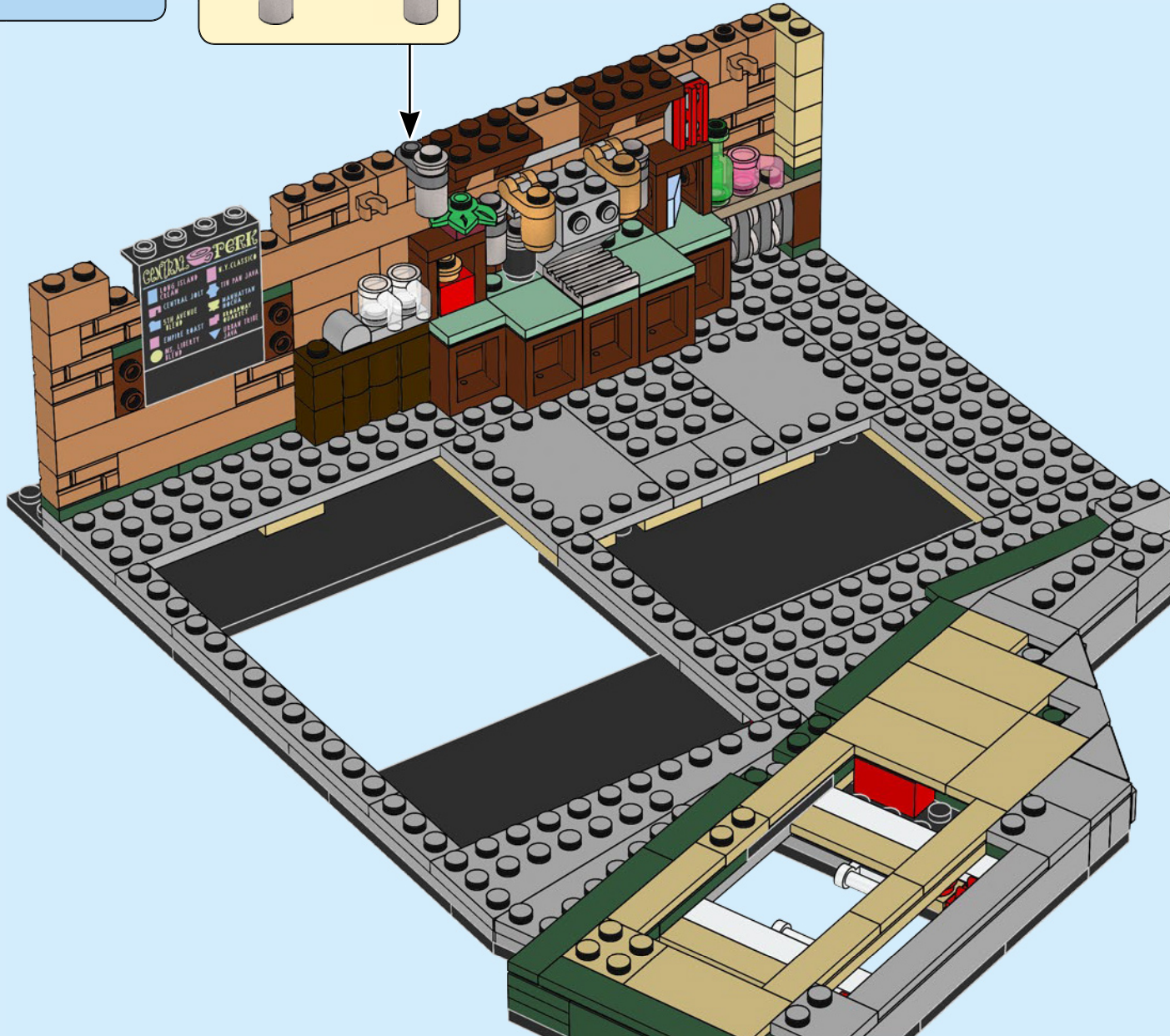

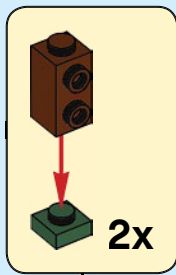
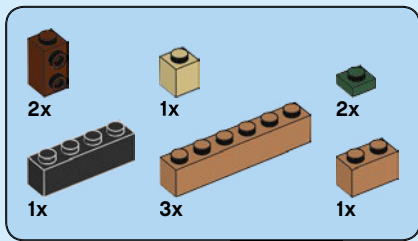

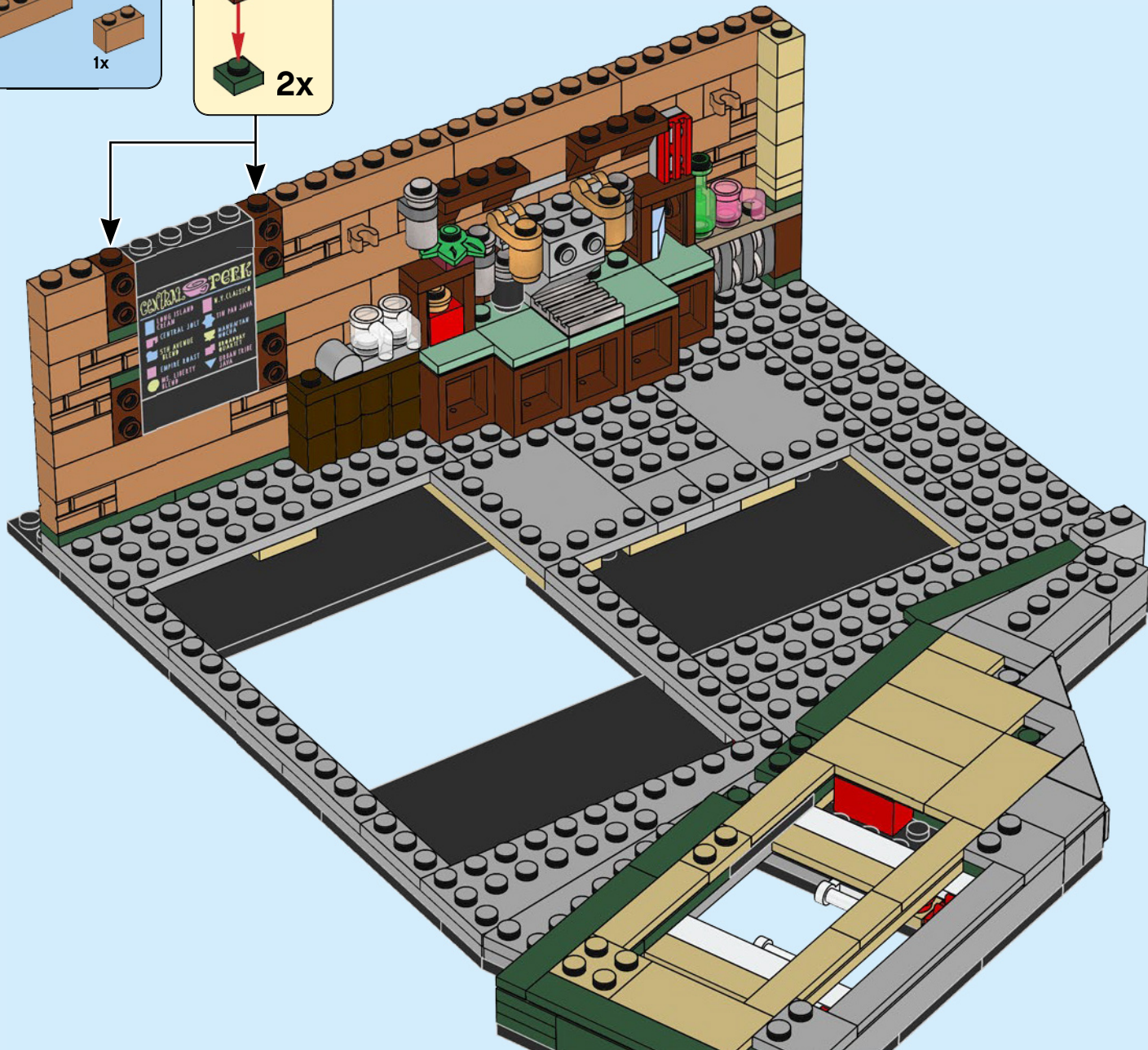

61

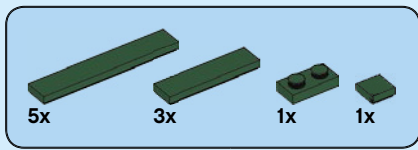

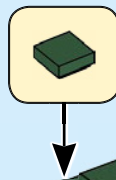

63



4x  1x 

64

3x 

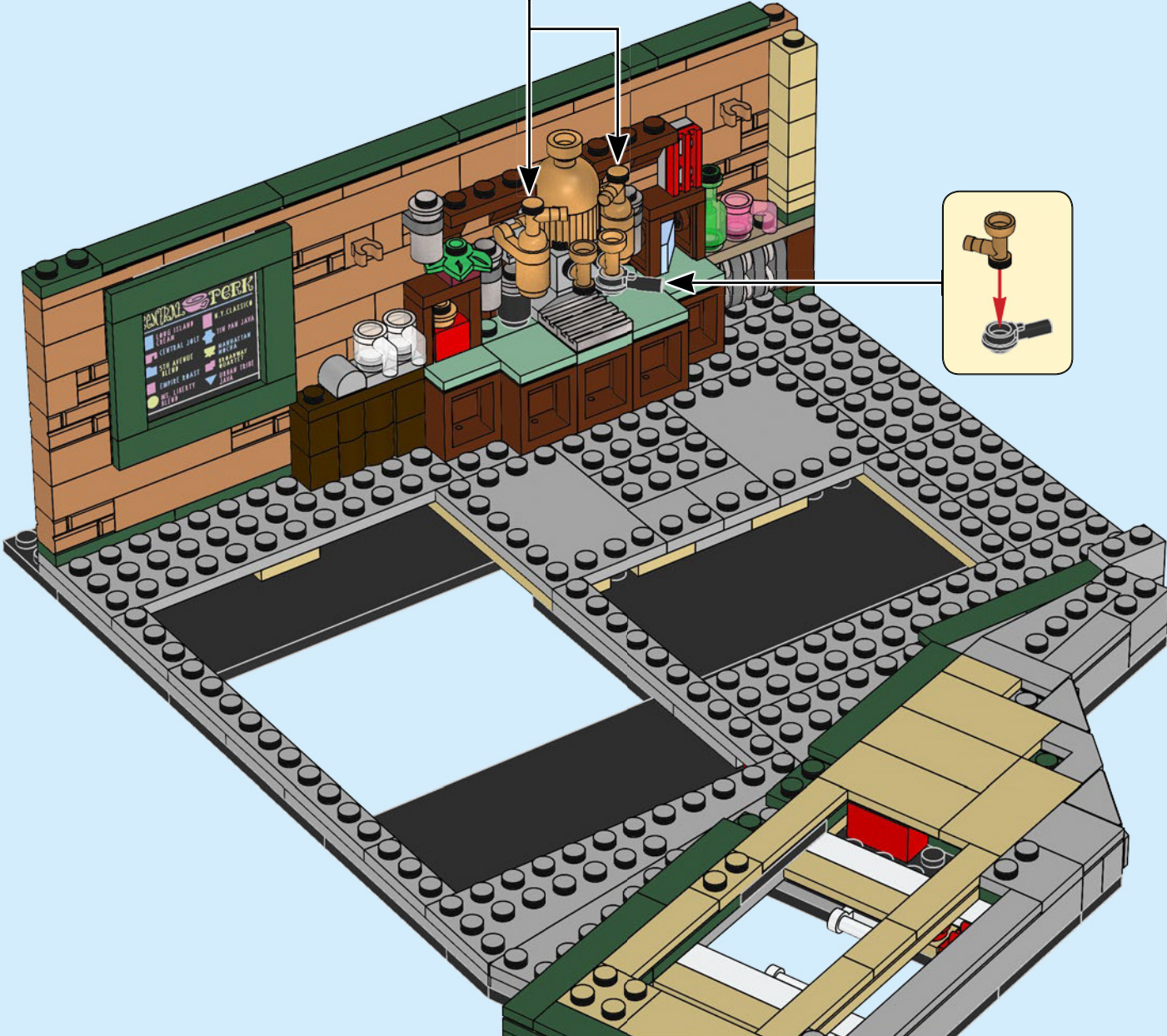

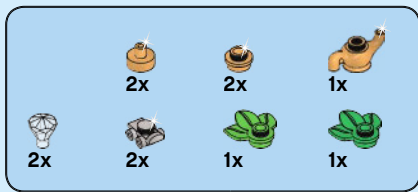

65

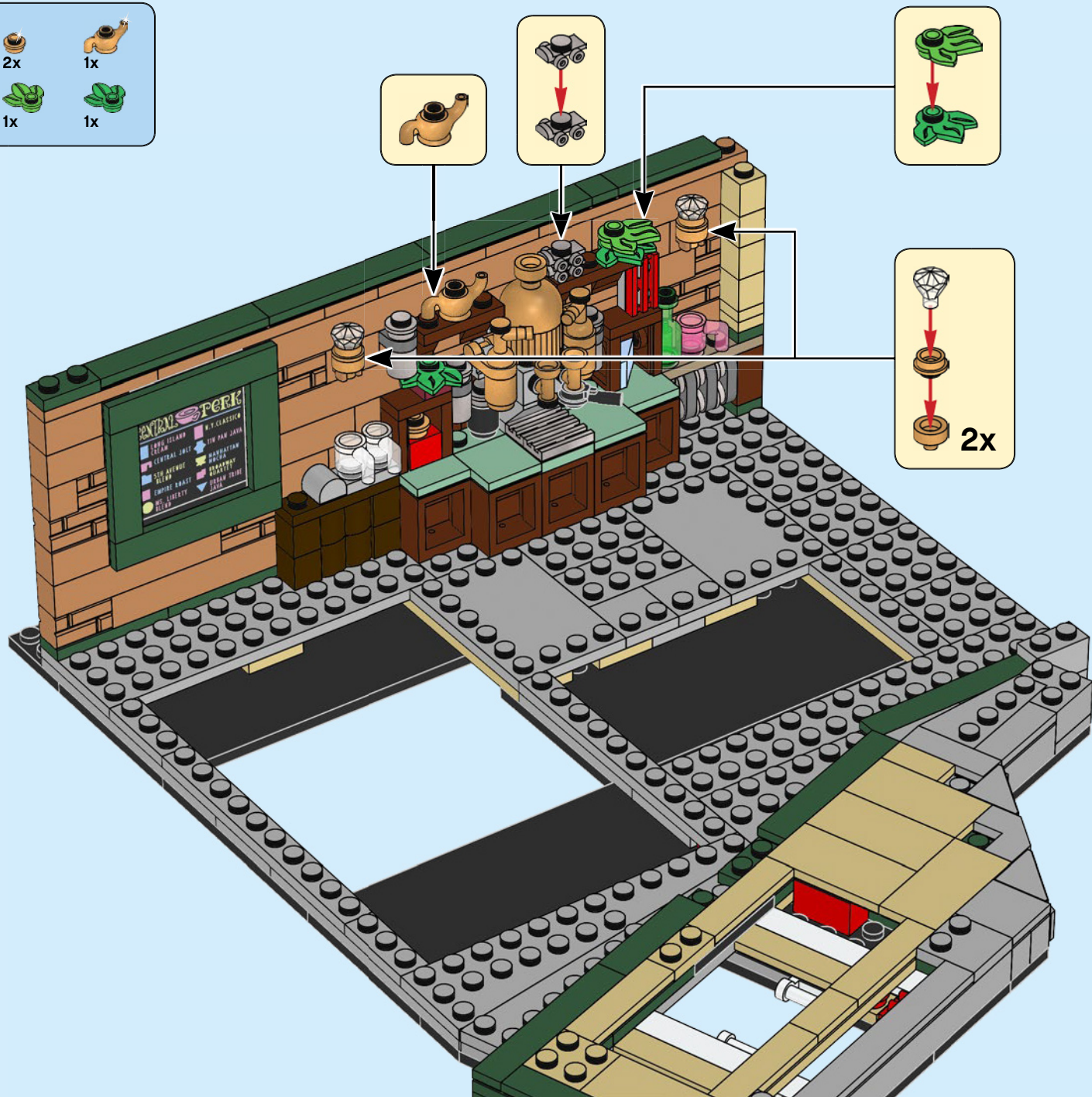

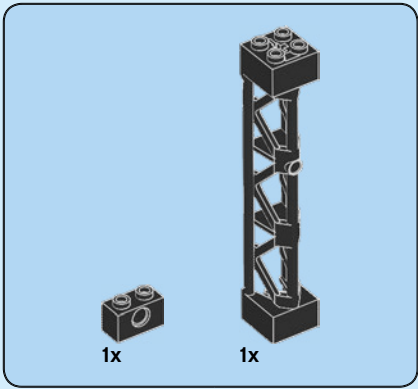

66

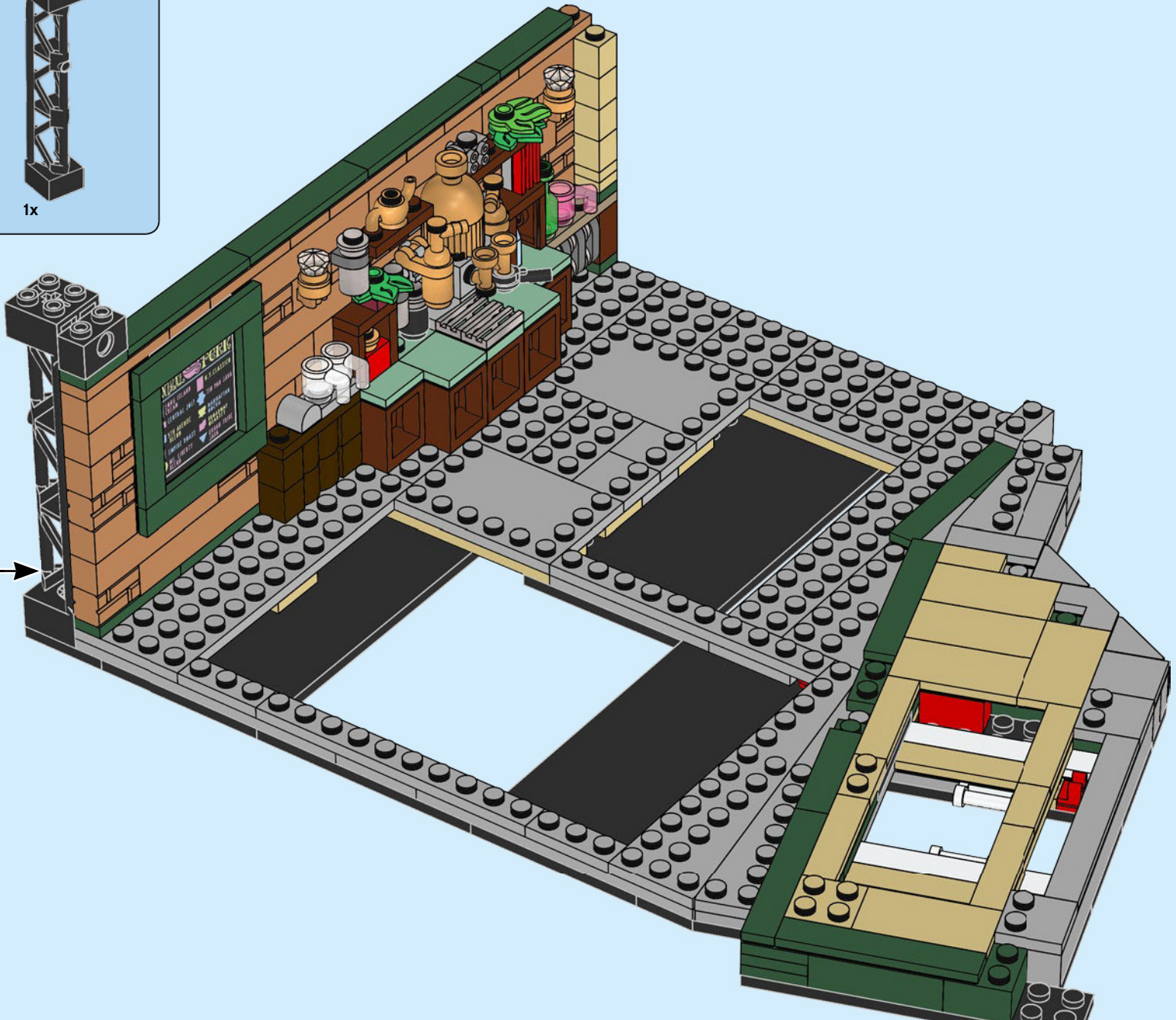
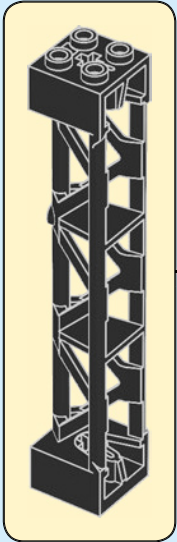

1x 1x

1x

67



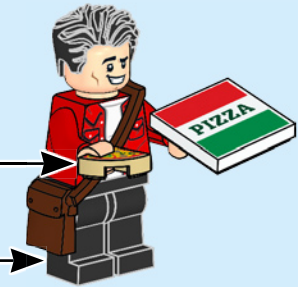
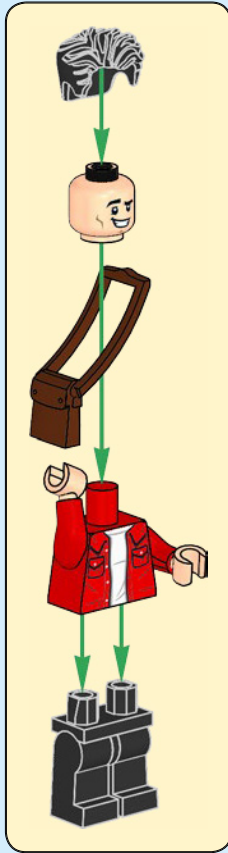
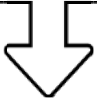
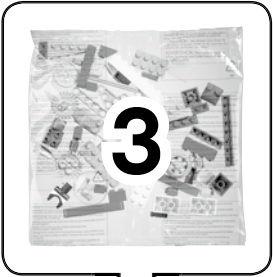

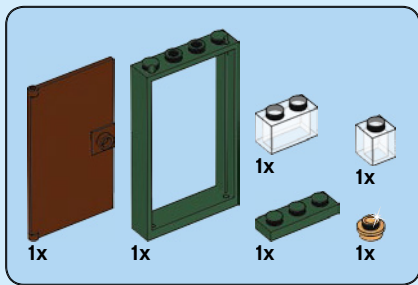

68

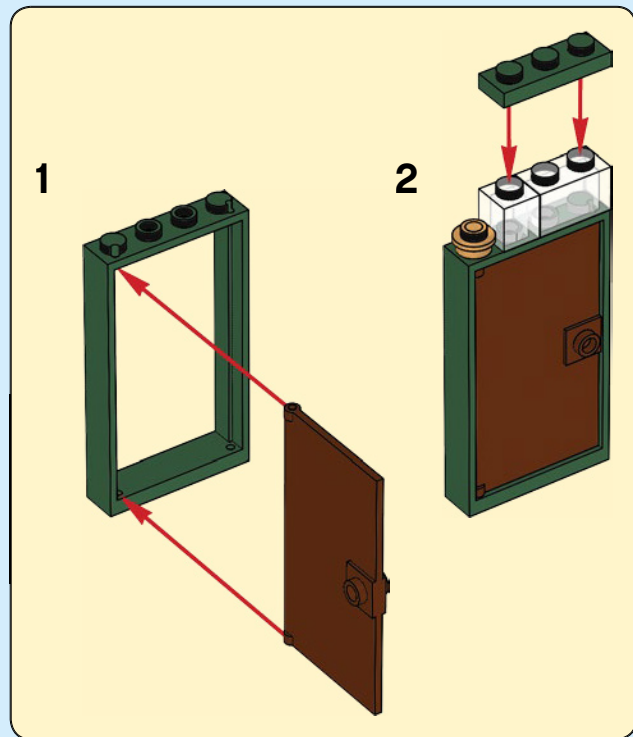
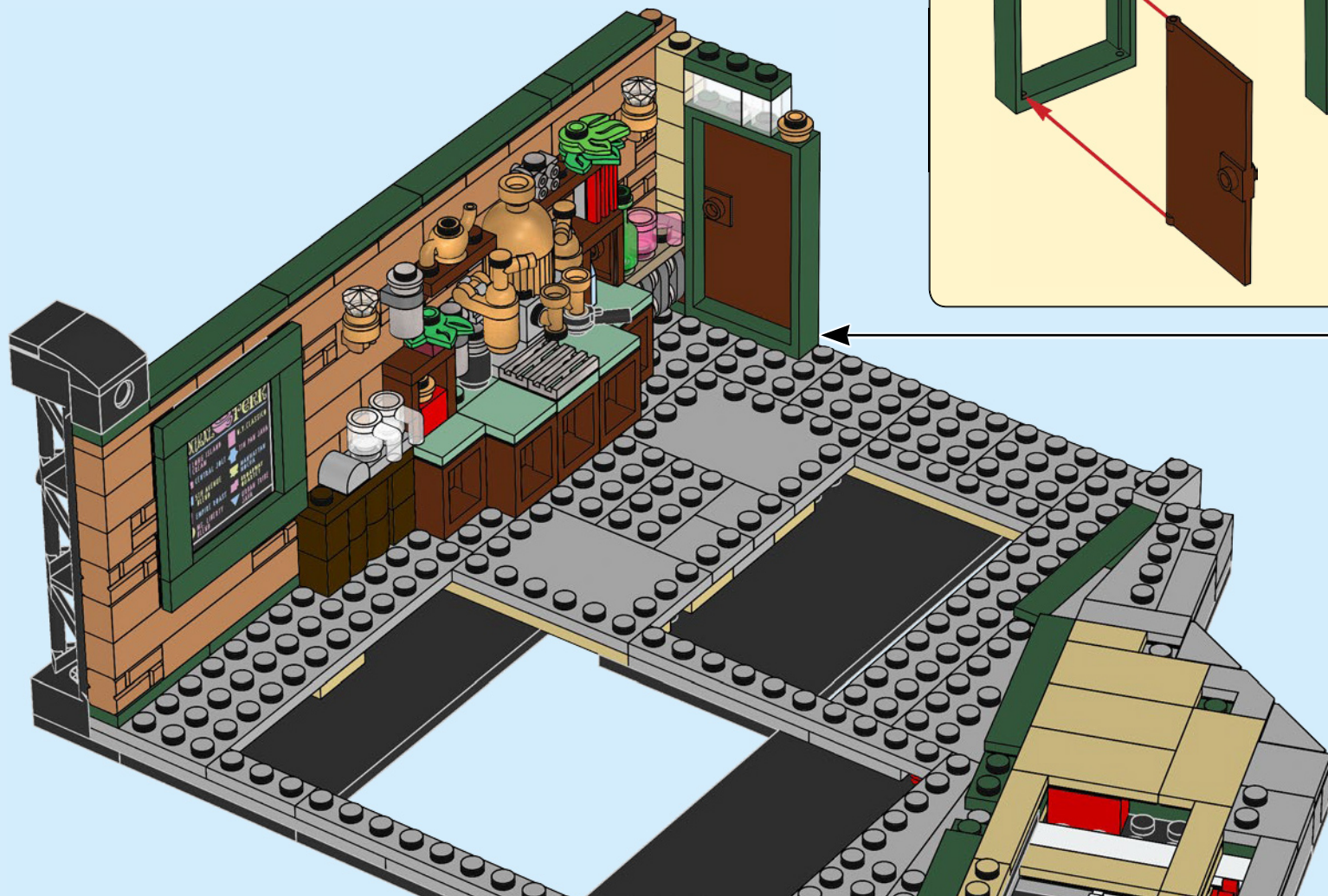

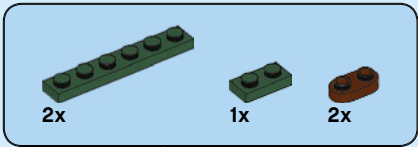



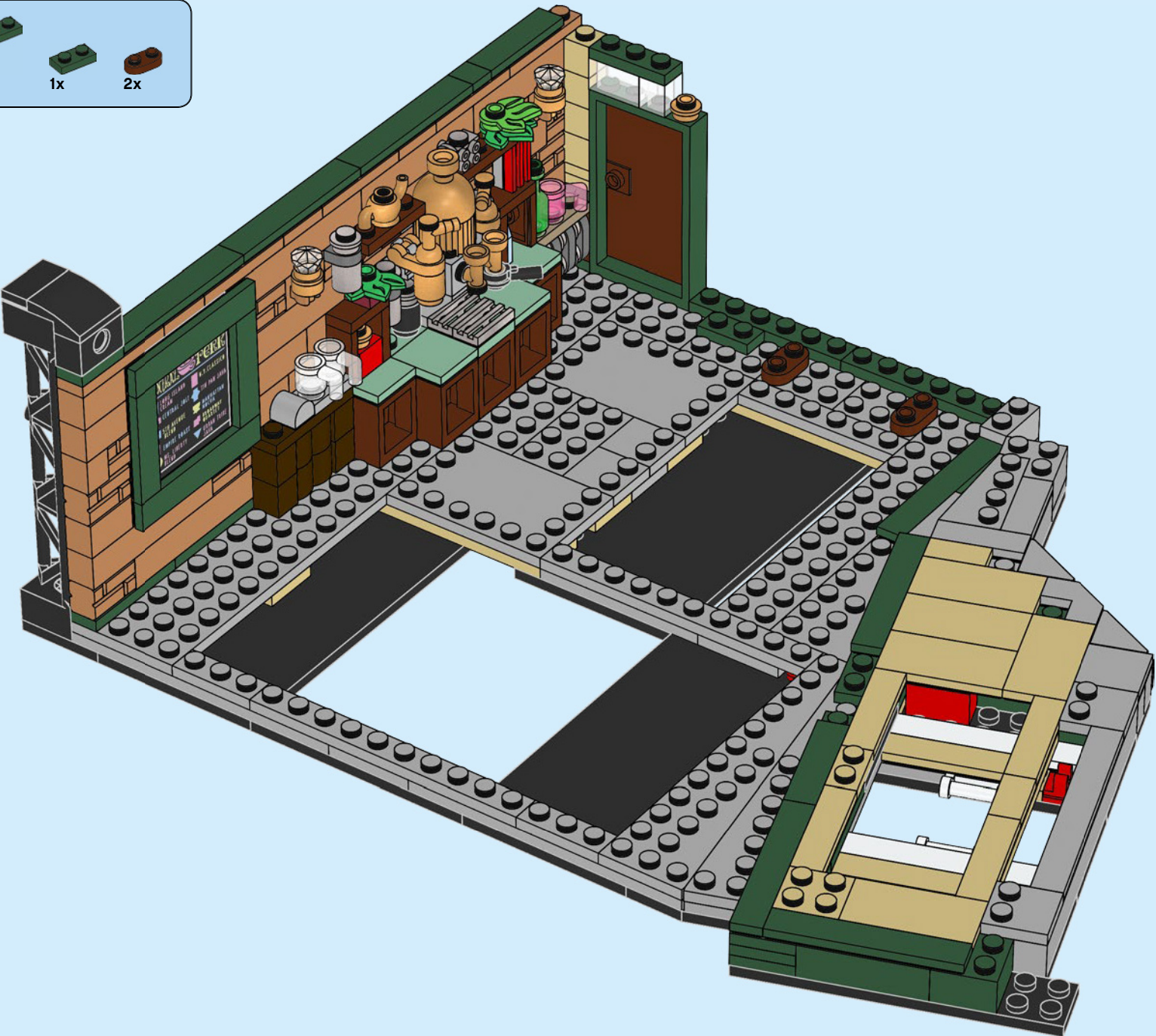

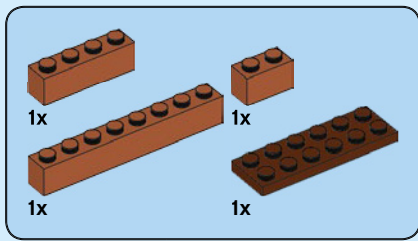
69



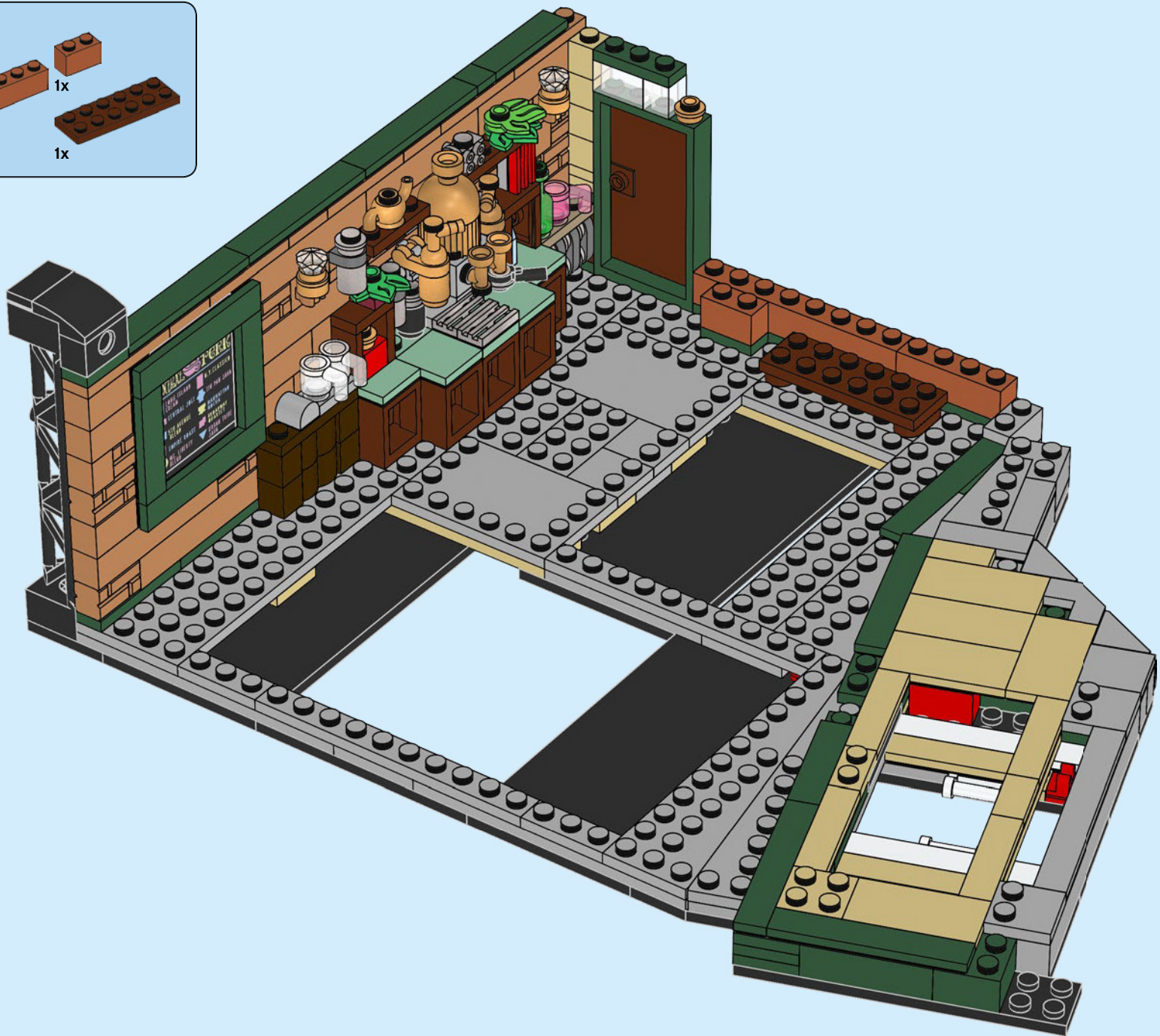

70



3x  1x  2x 

71

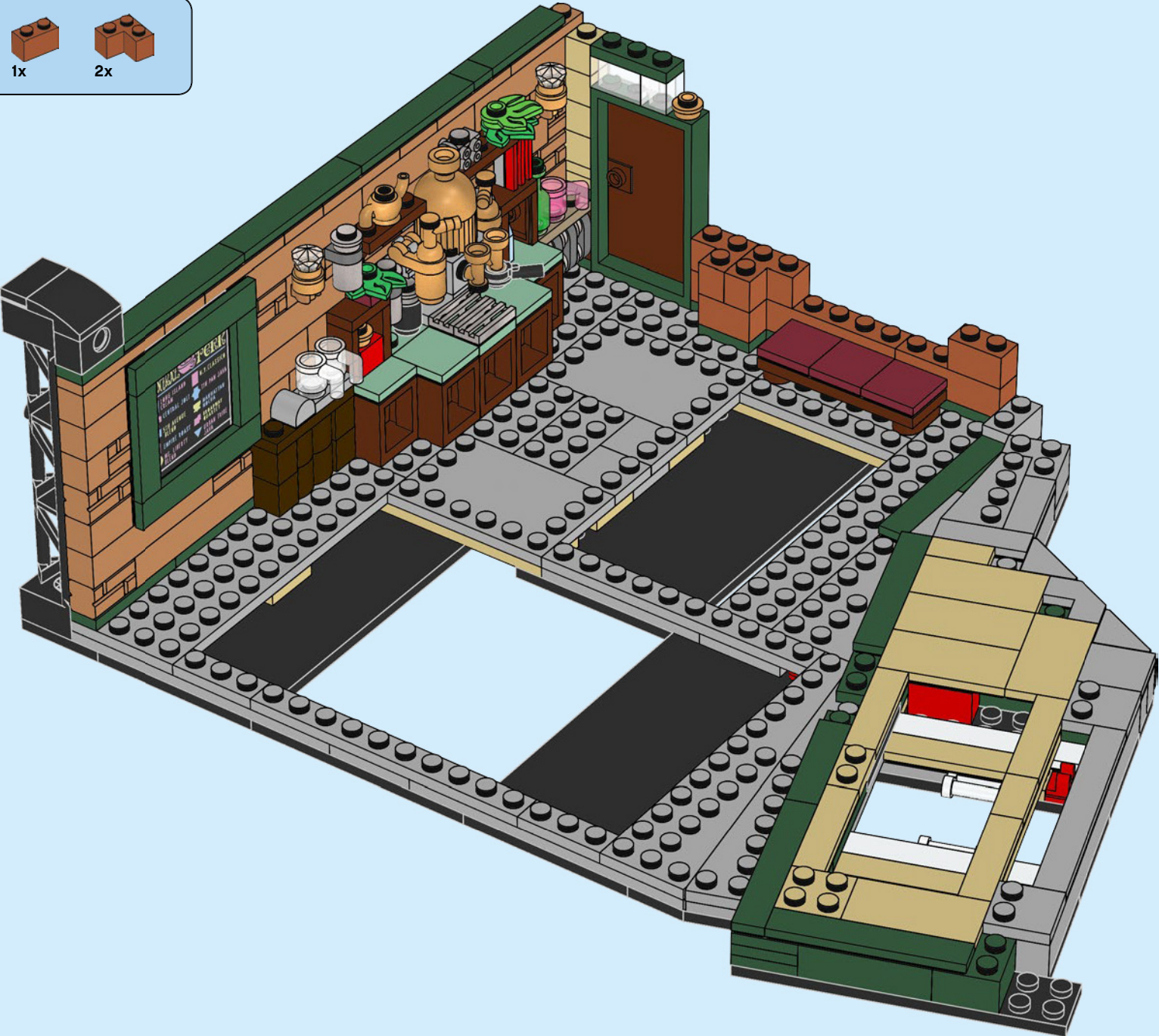

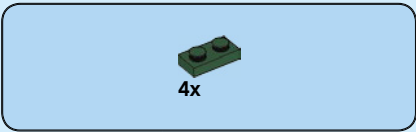

72



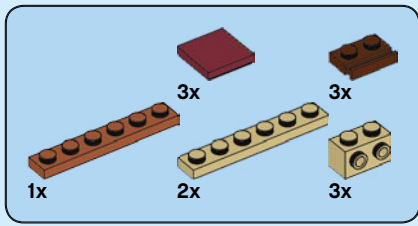

73

1

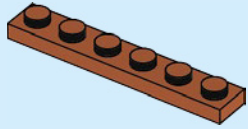

2

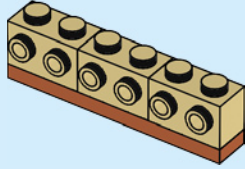

3

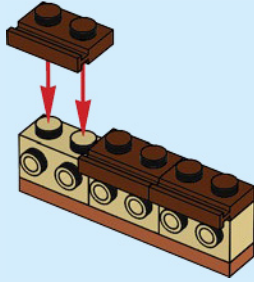

4

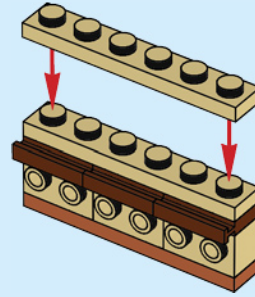

5

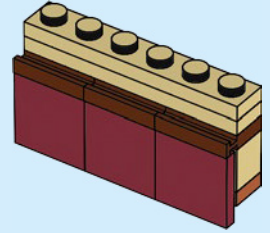

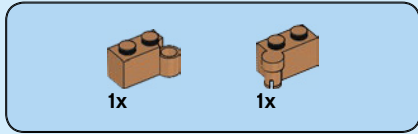
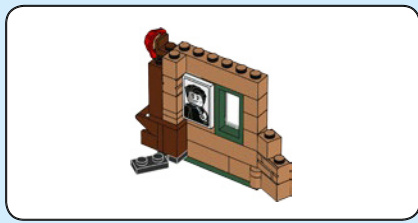

74

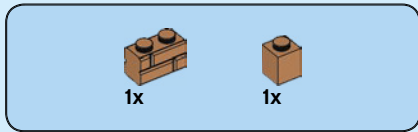
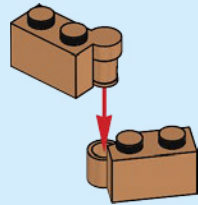

75

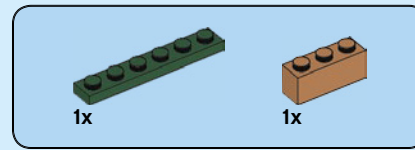
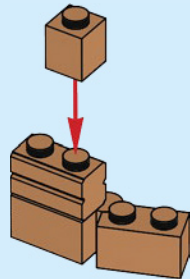

76

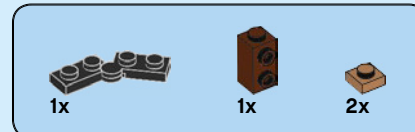
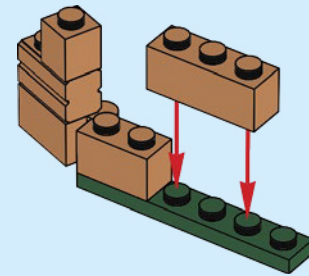

77

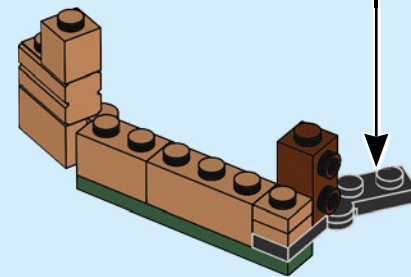
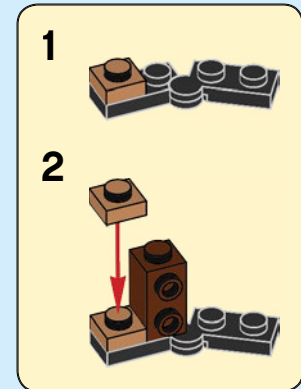

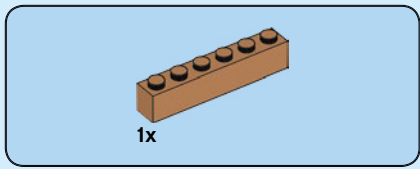

78

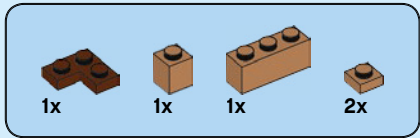
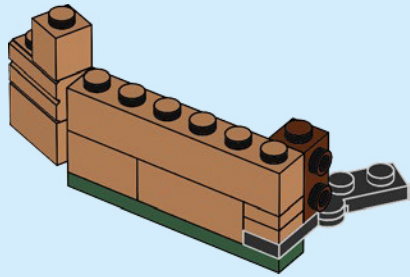

79

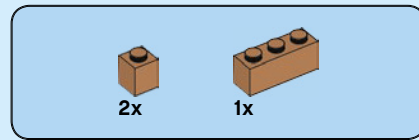
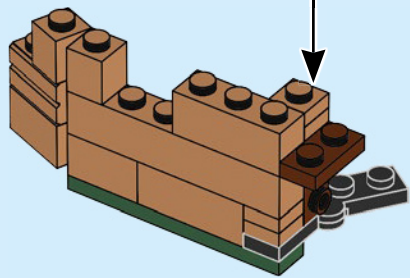
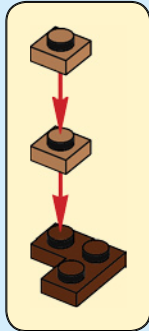

80

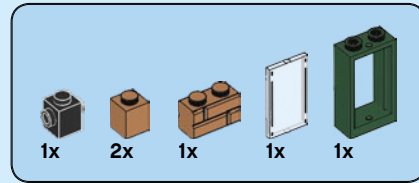
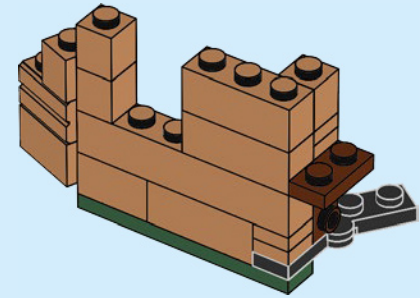

81

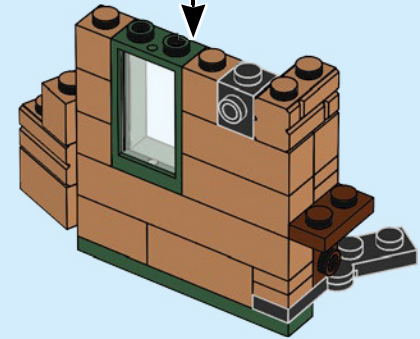
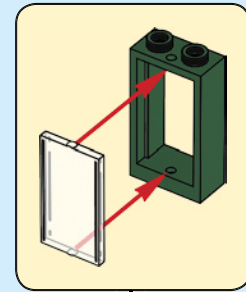

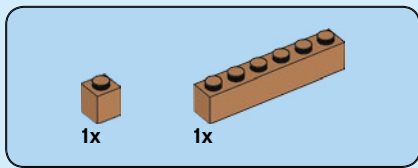

82

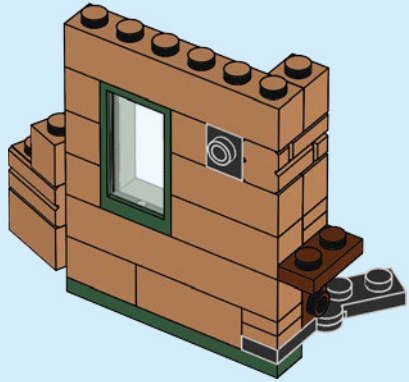

83

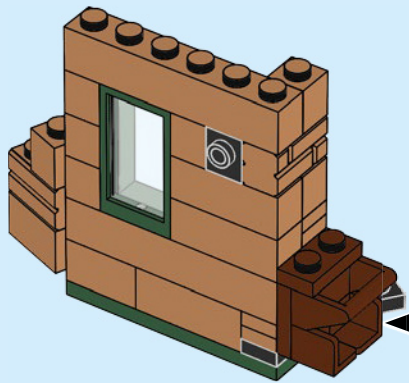
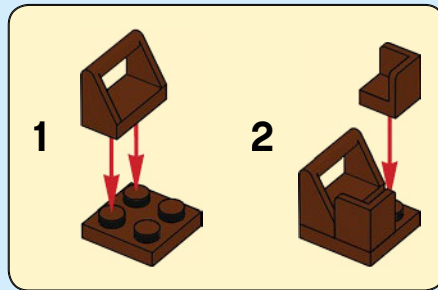

84

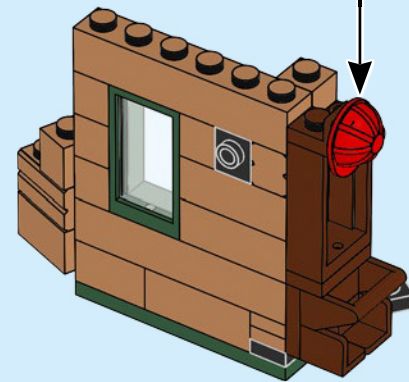
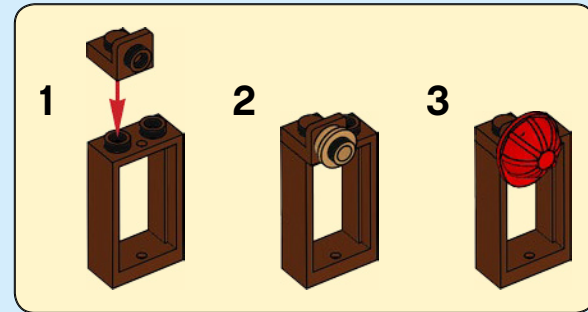

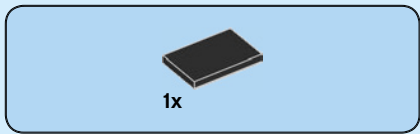

85

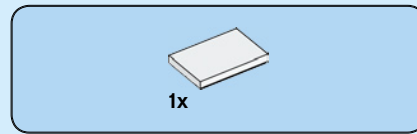
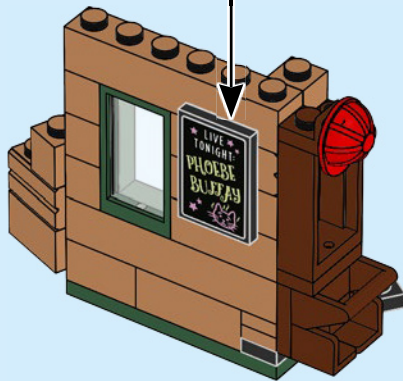
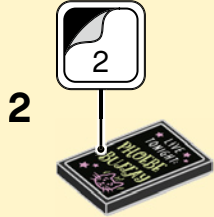
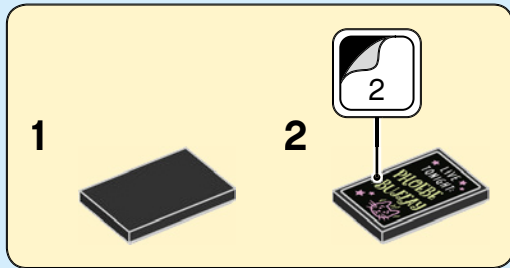

86

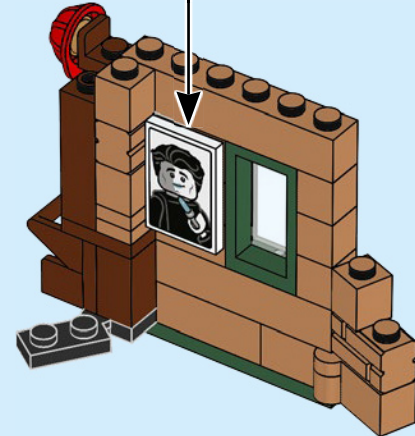
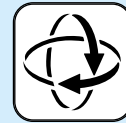
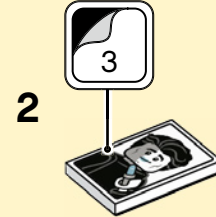
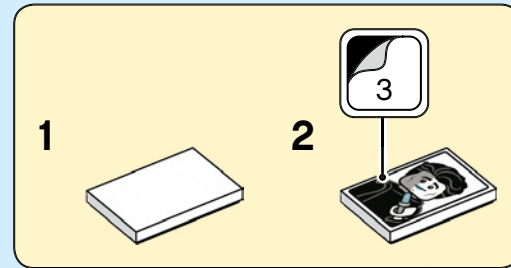

87

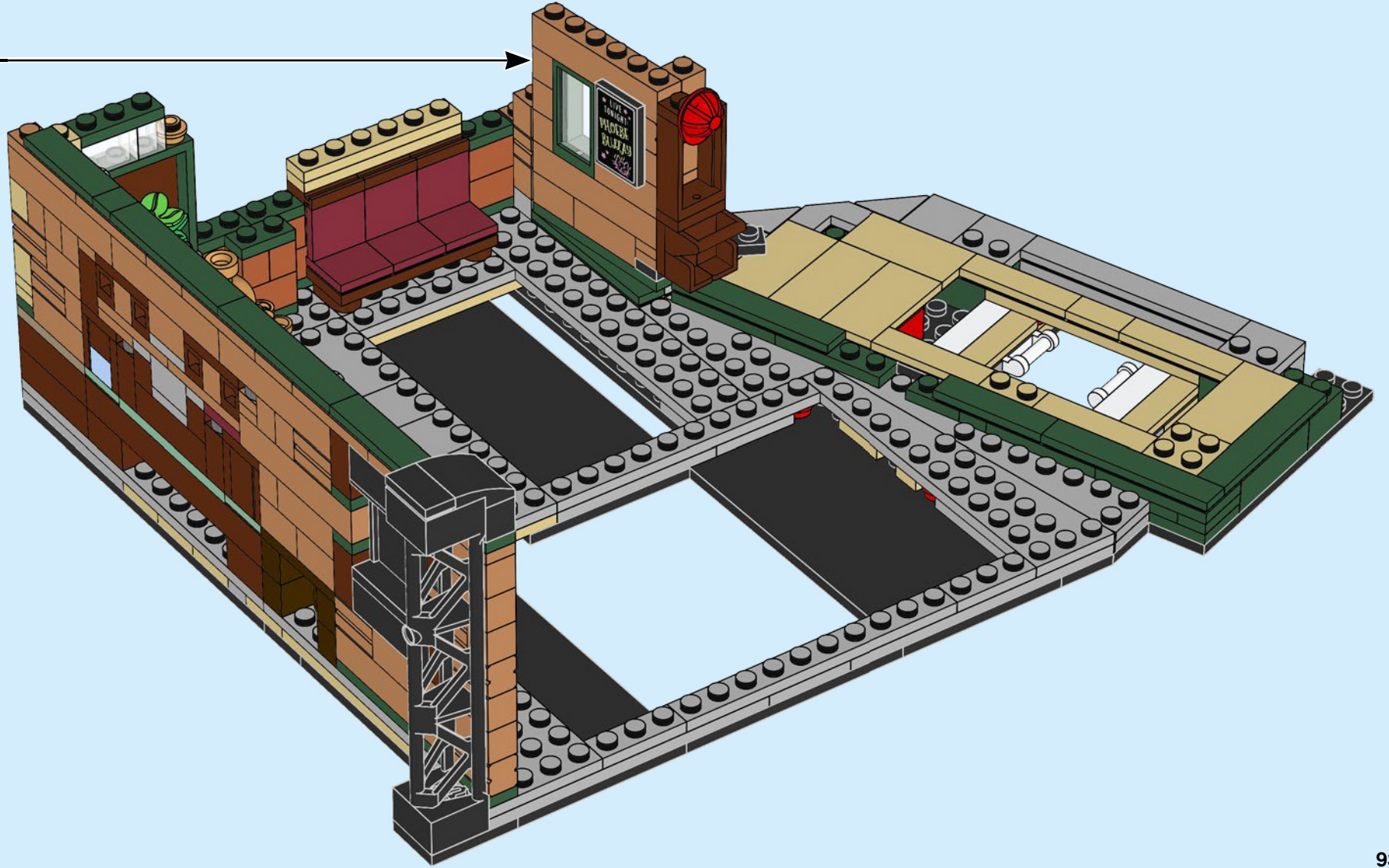

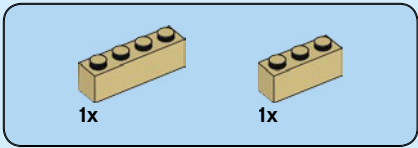

88

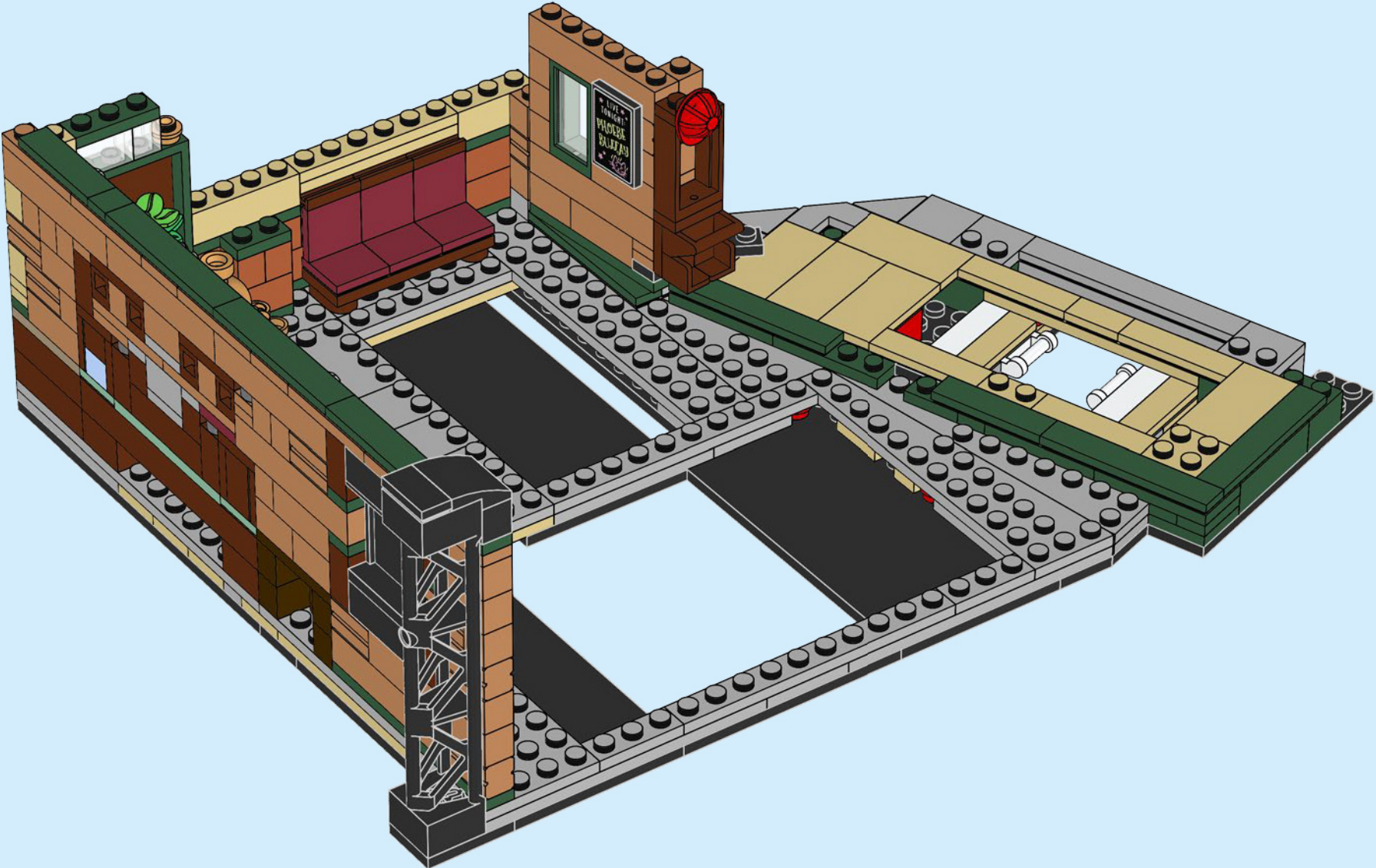

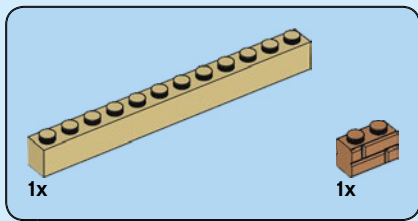

89

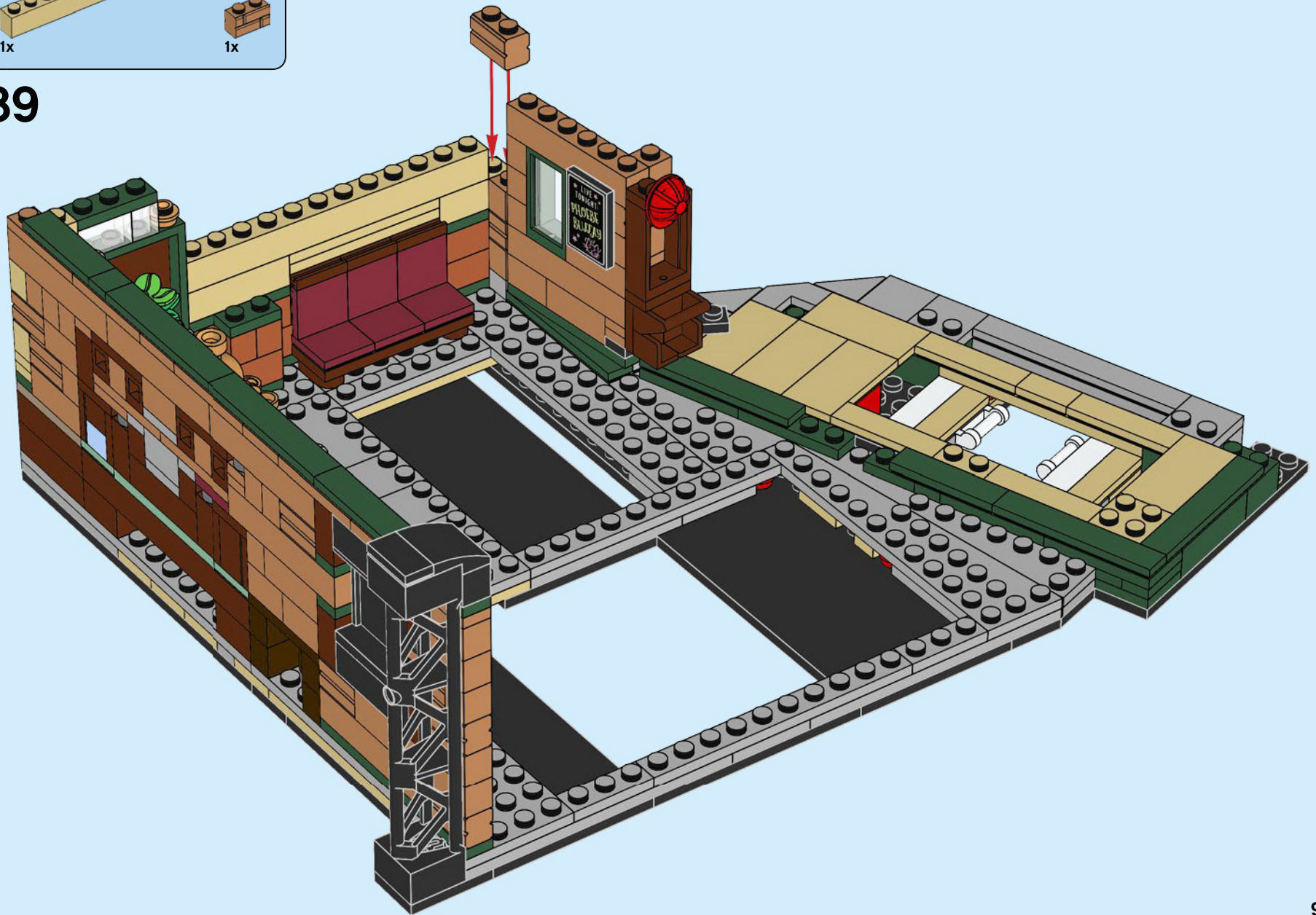

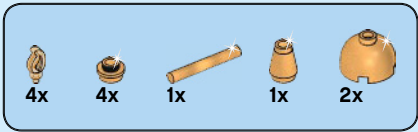

90

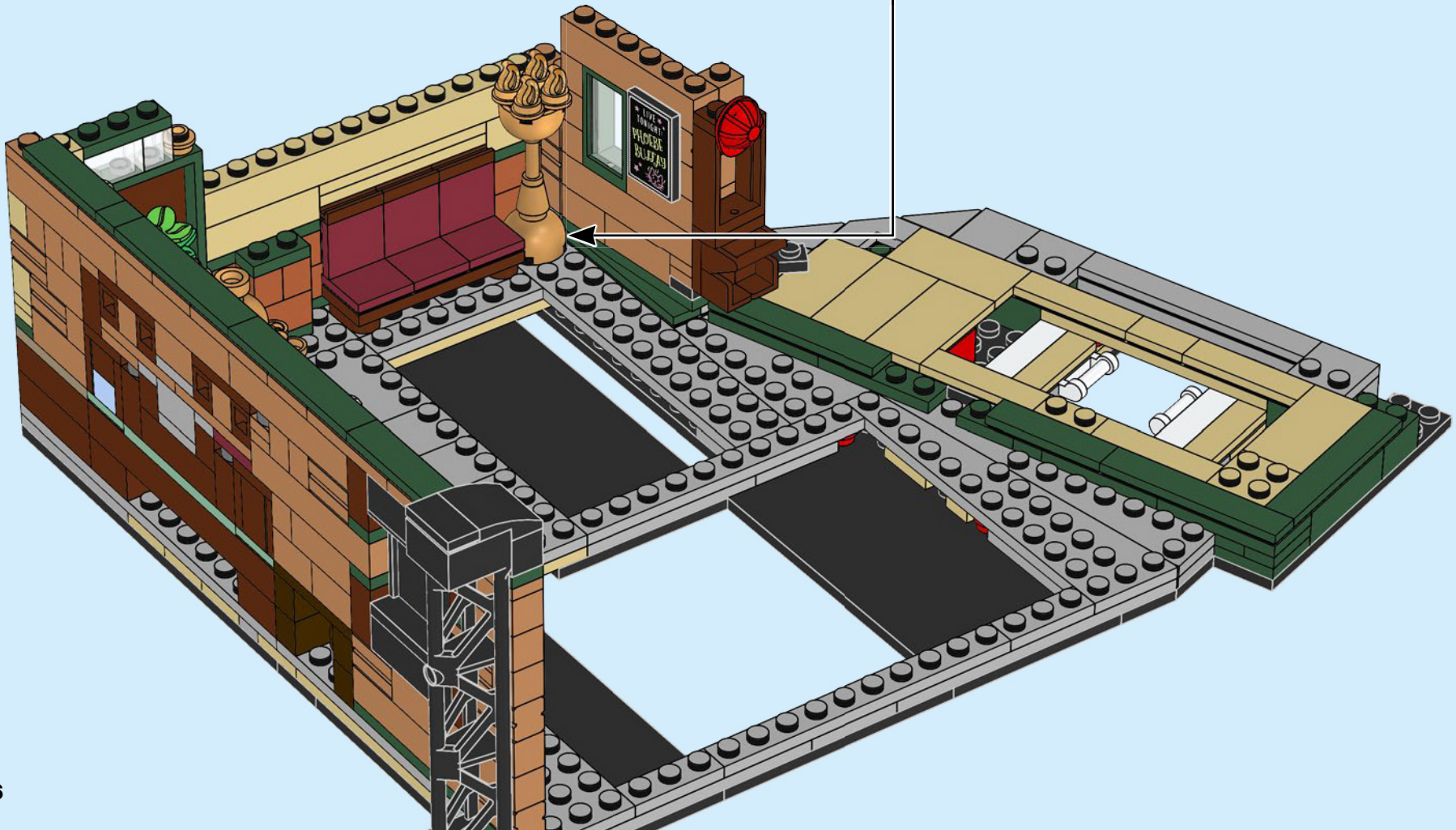
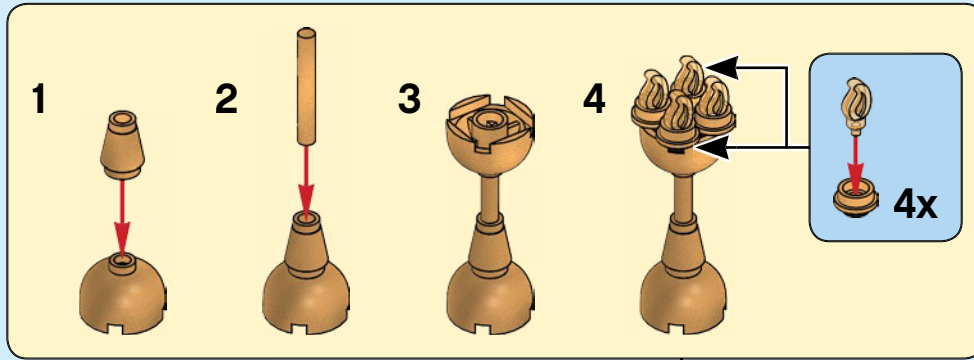

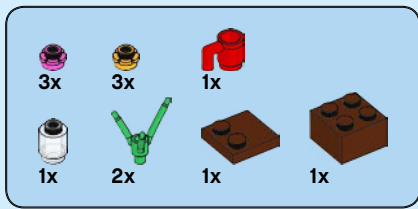

91

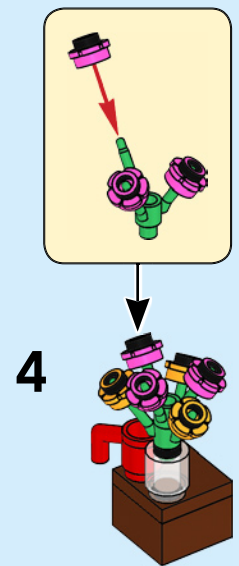
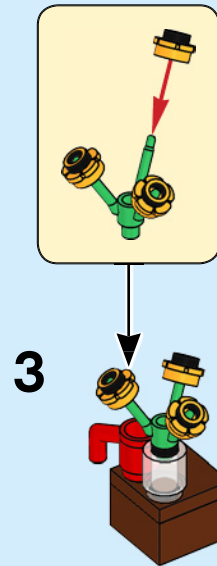
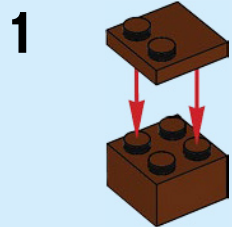

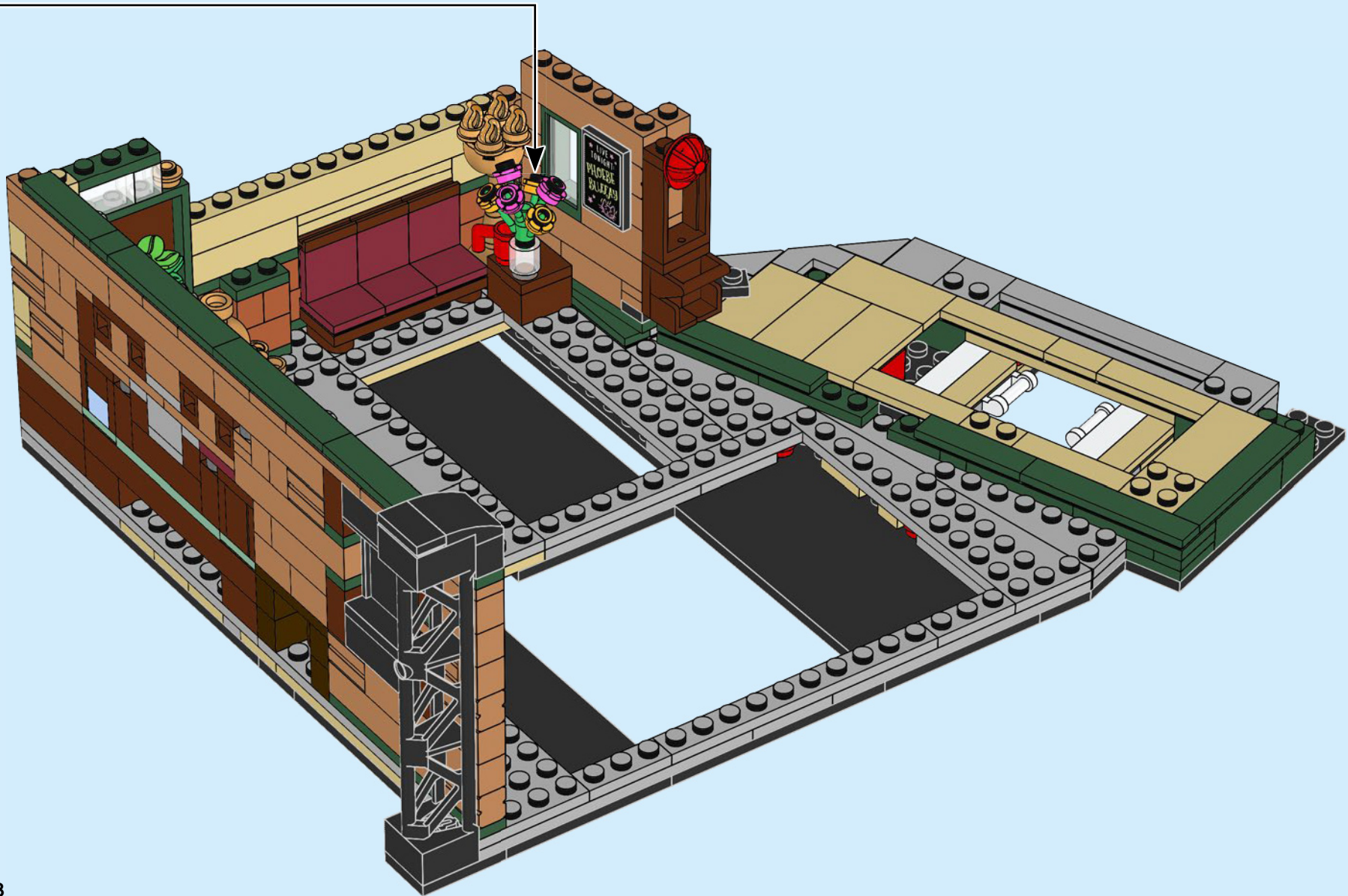

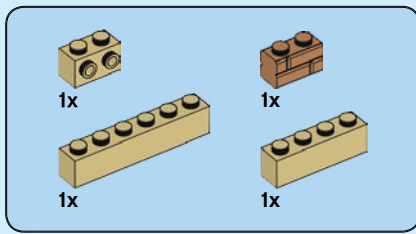

92

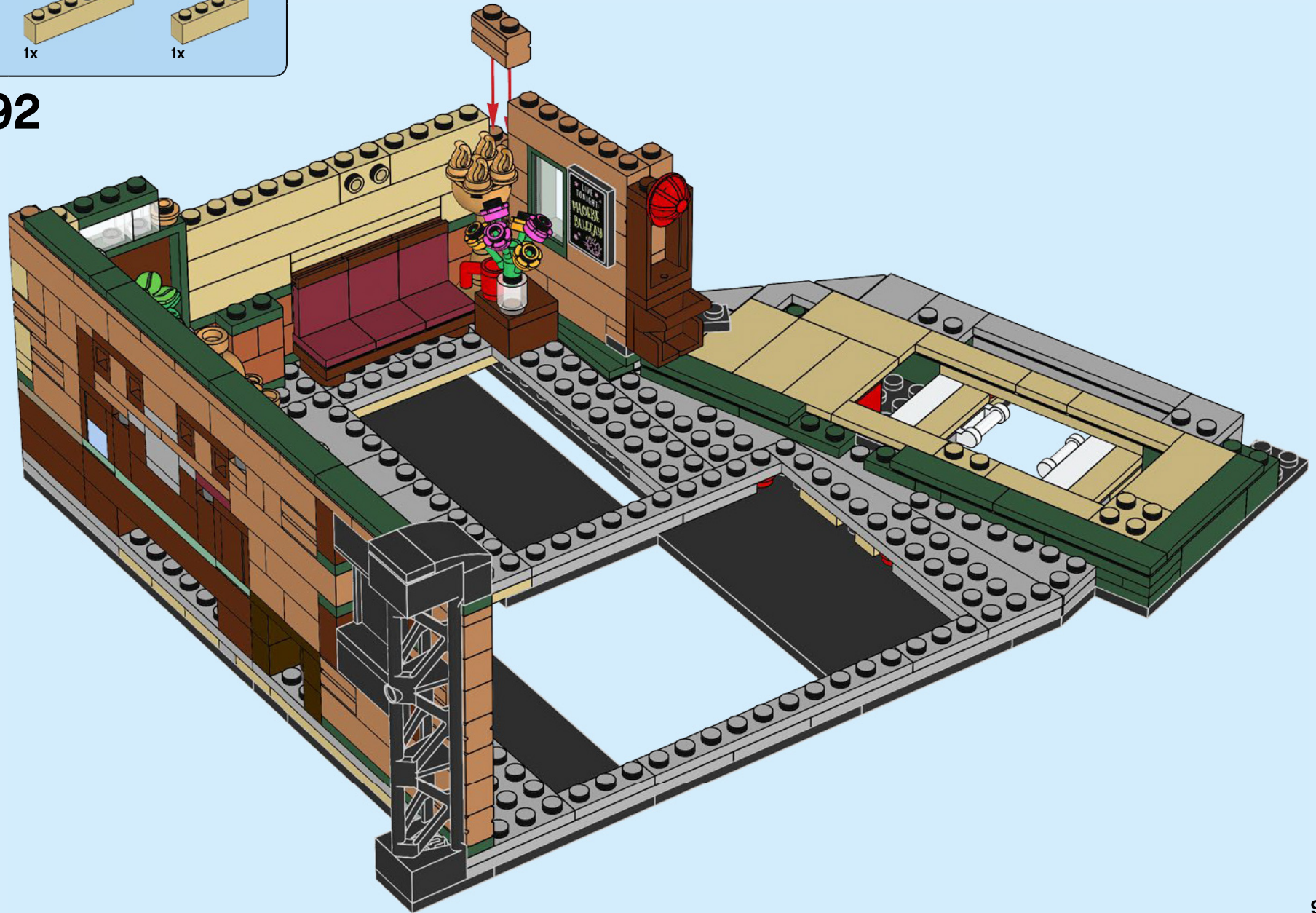

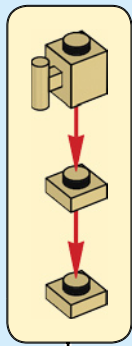
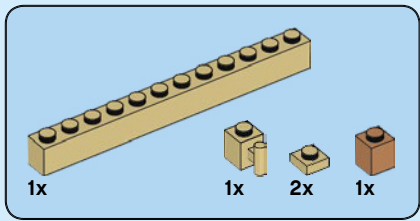

93

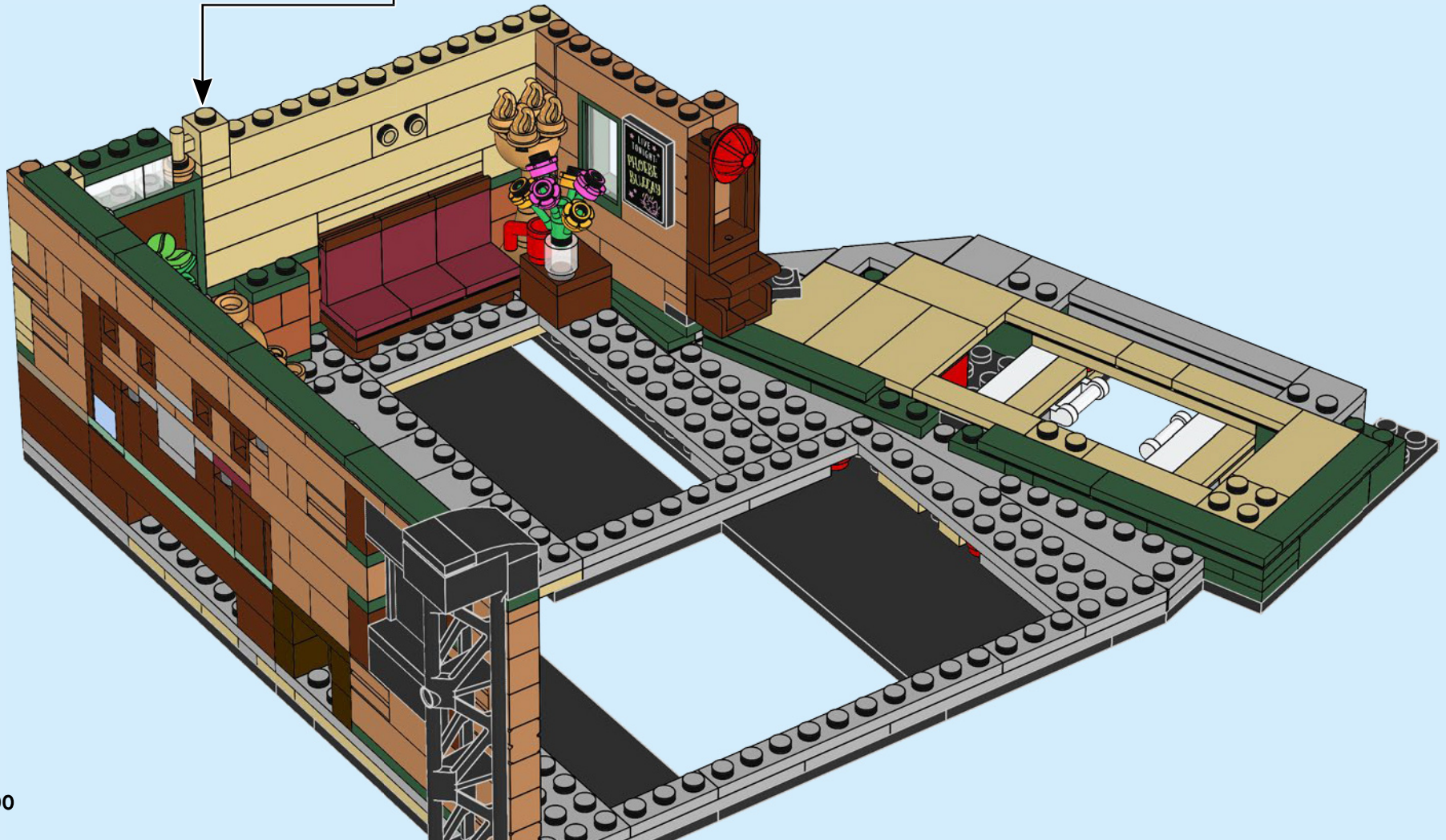

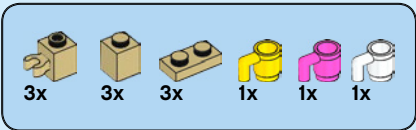

94

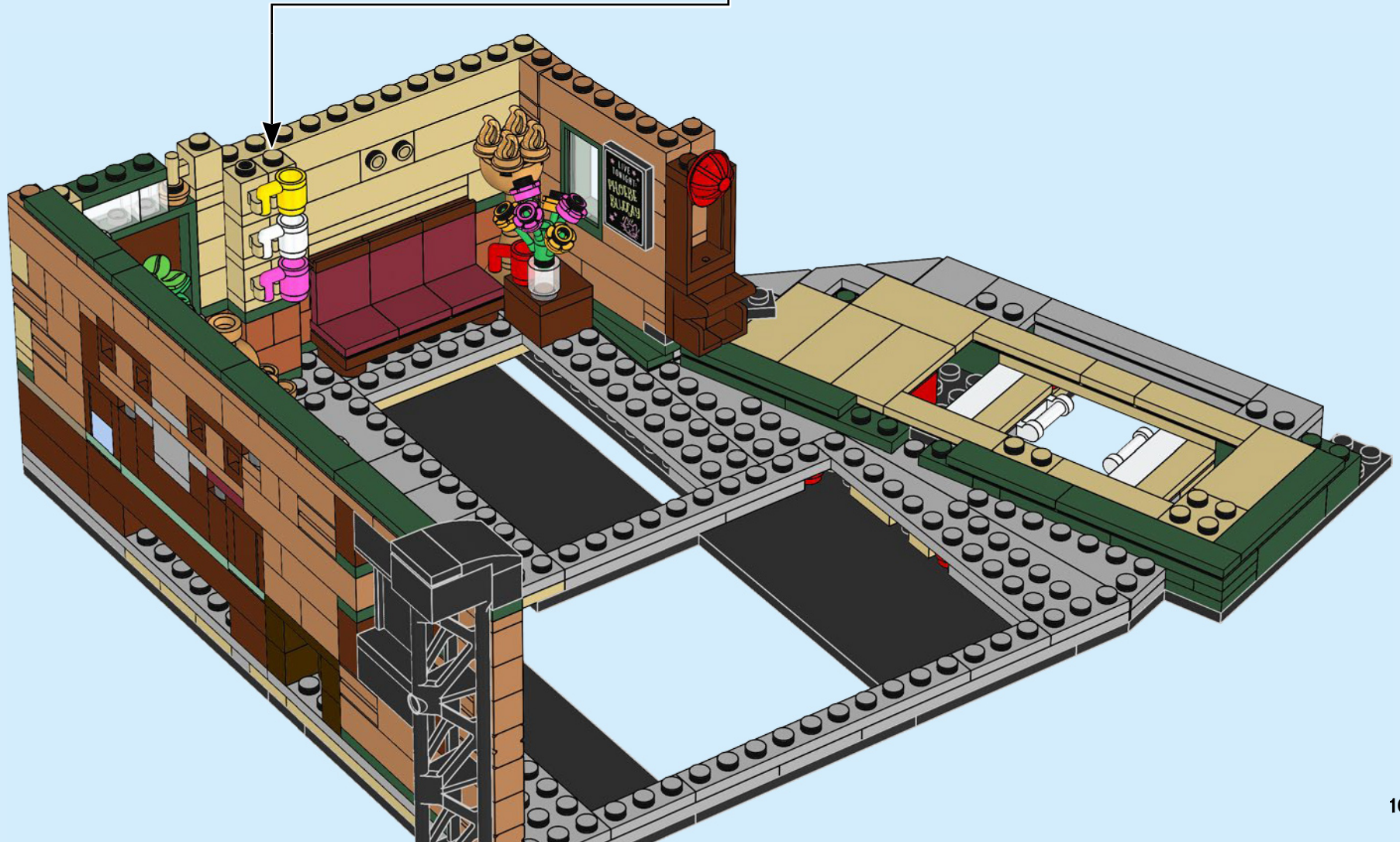
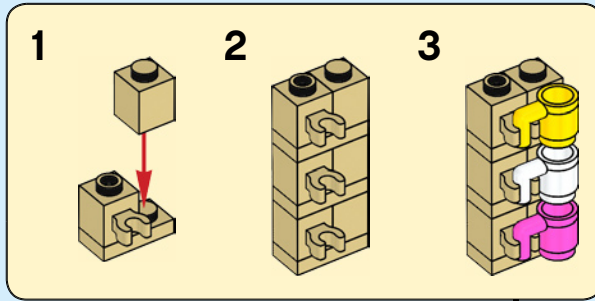

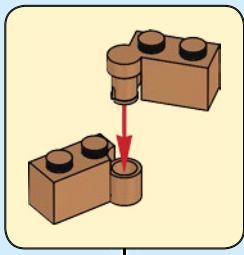
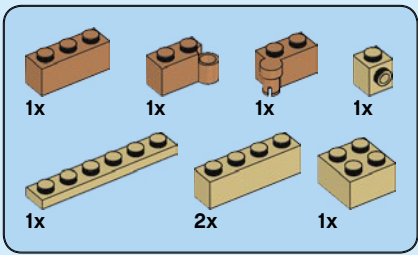

95

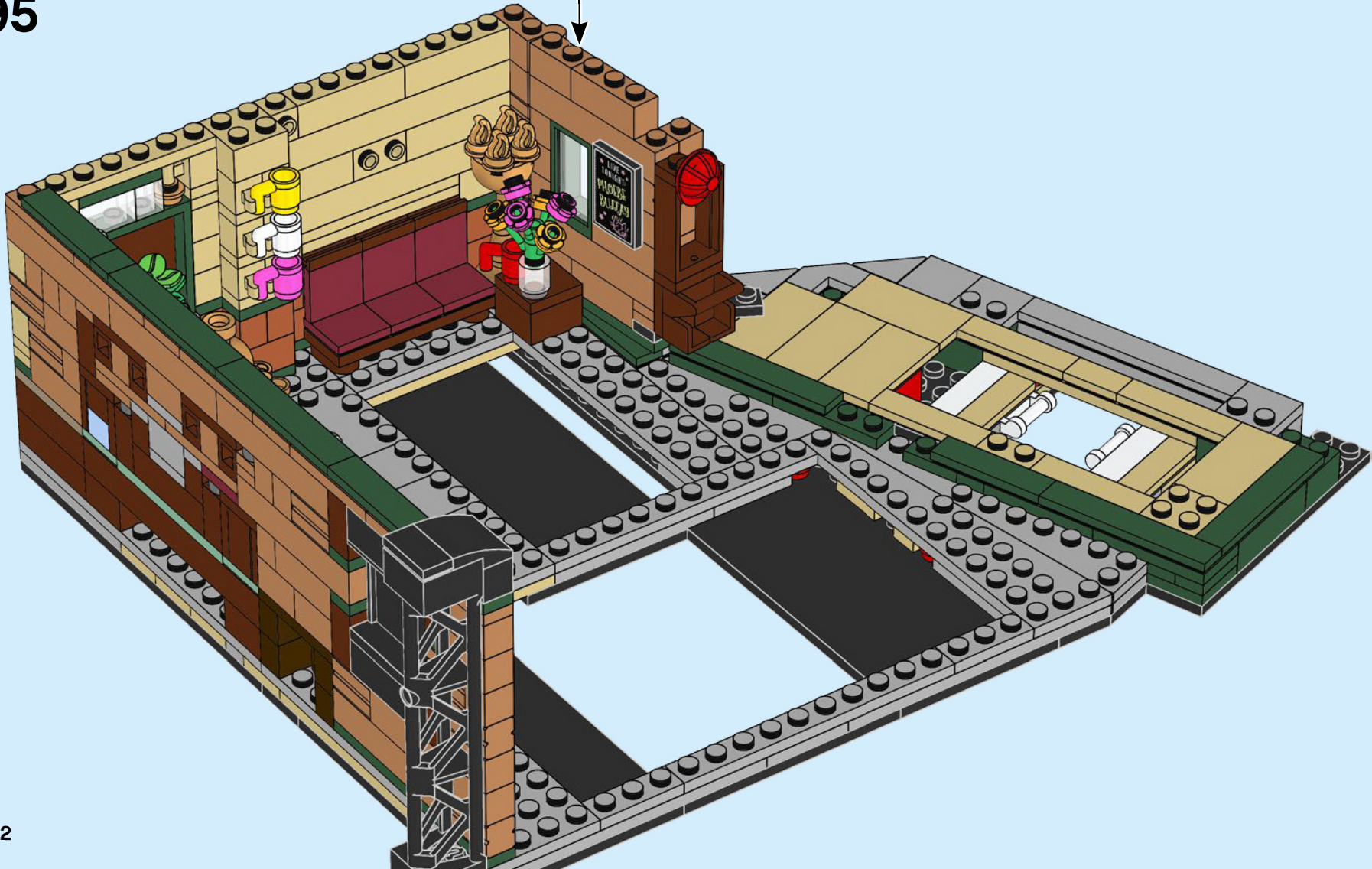

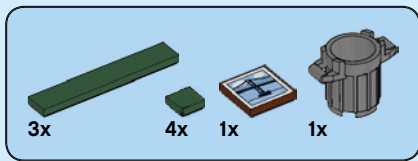

96



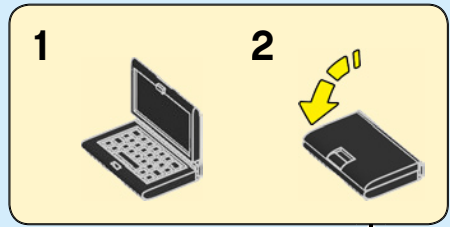
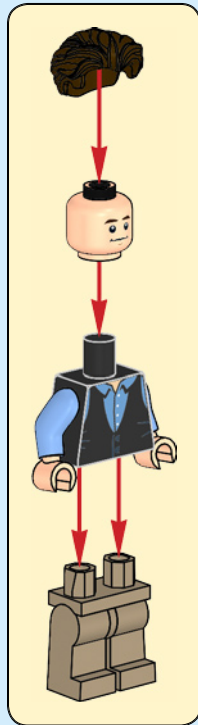
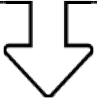

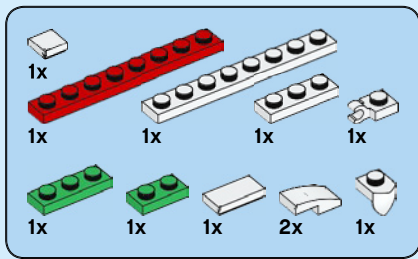

97

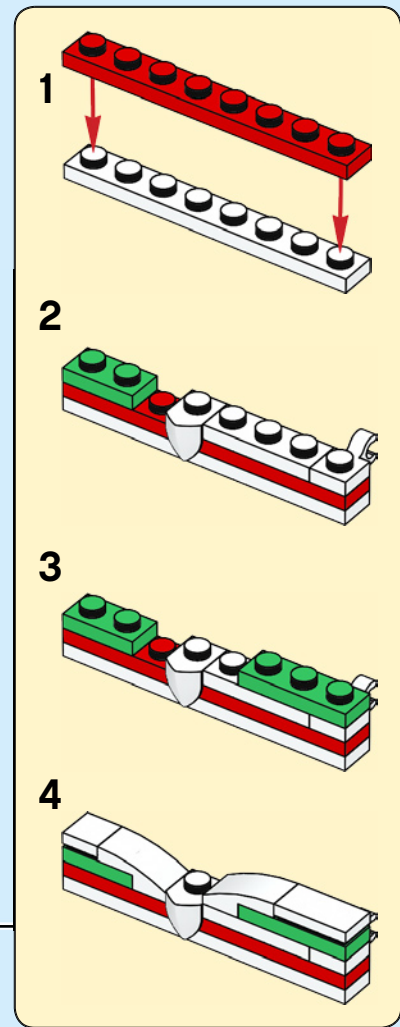

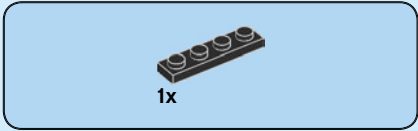
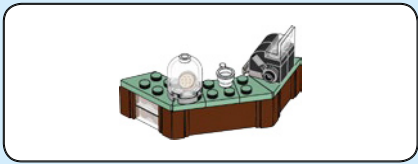

98

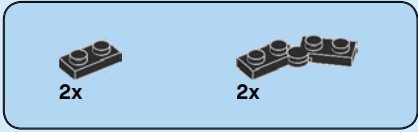

99

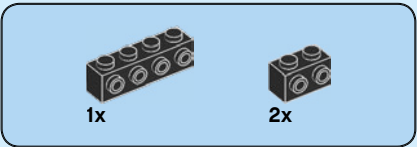
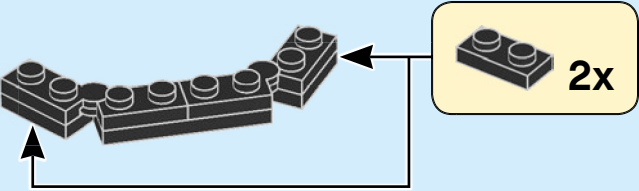

100

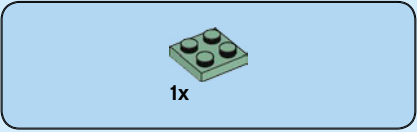
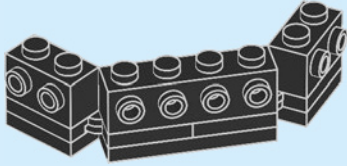

101

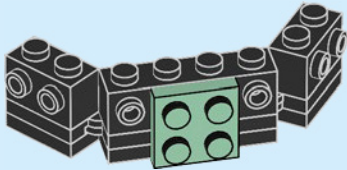

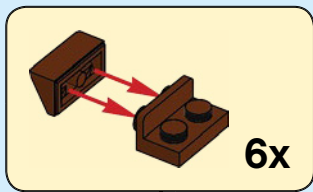
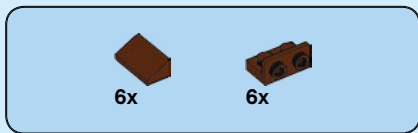

102

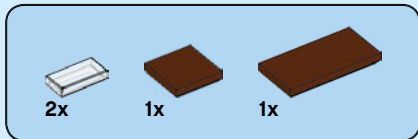
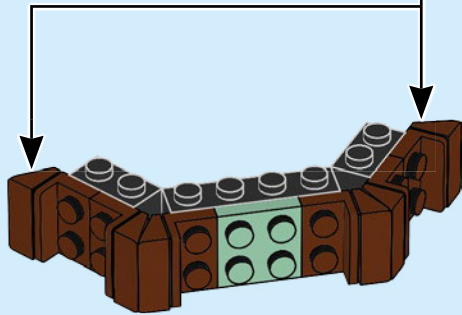

103

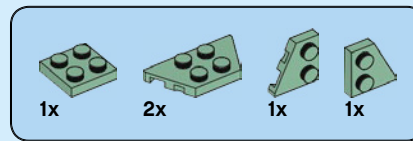
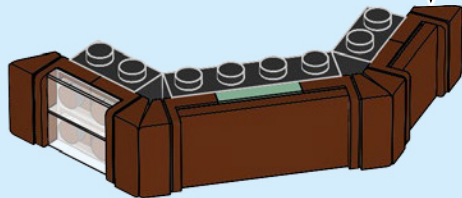

104

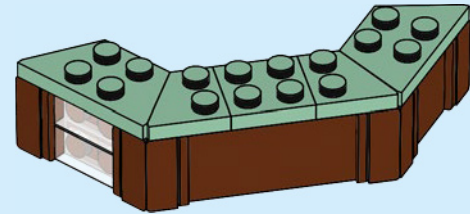

105

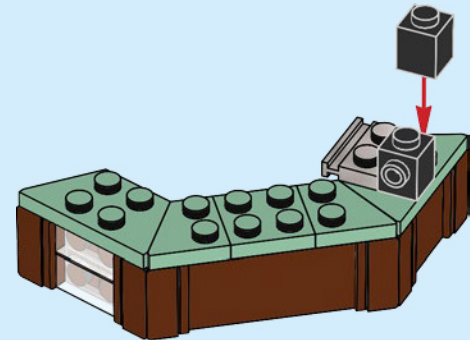



2x

106

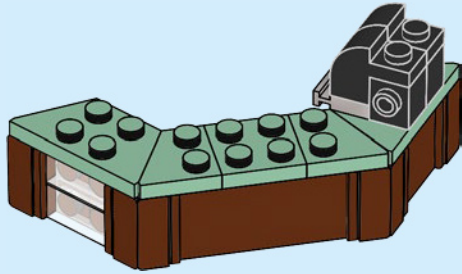

1x



1x



1x



1x

108

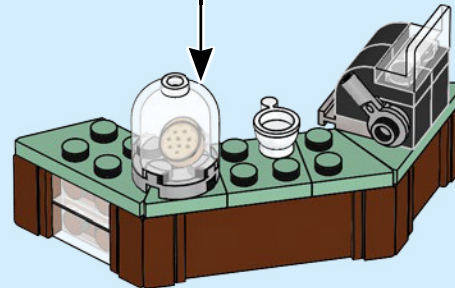
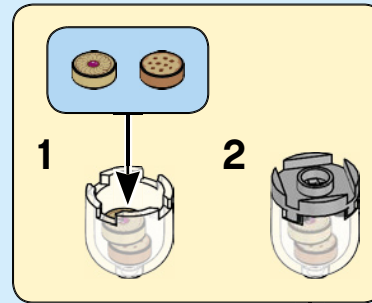

1x



1x



1x

107

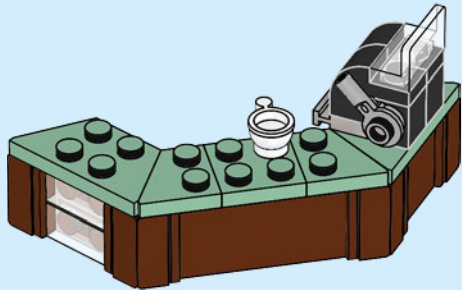



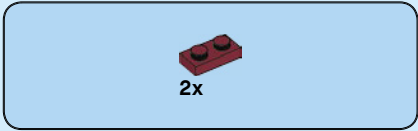
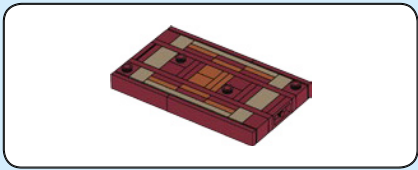

110

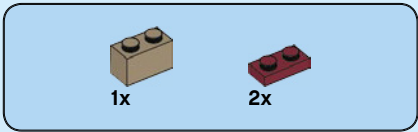
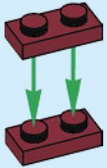

111

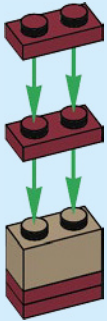

112

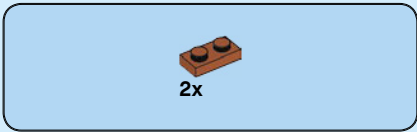

113

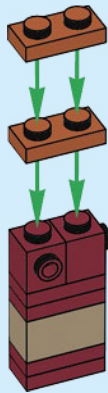



2x

114

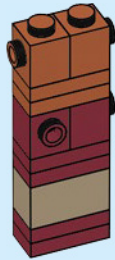

2x

115

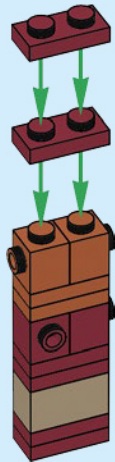

2x

116



1x



1x



1x

117



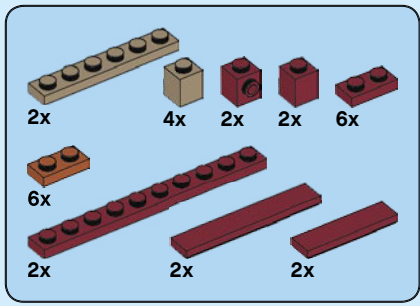

118

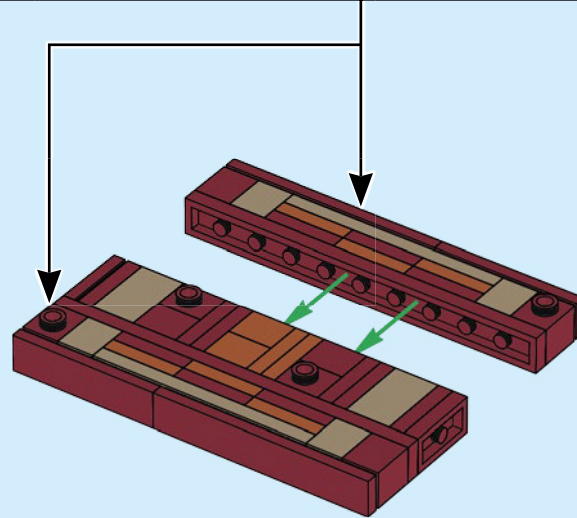
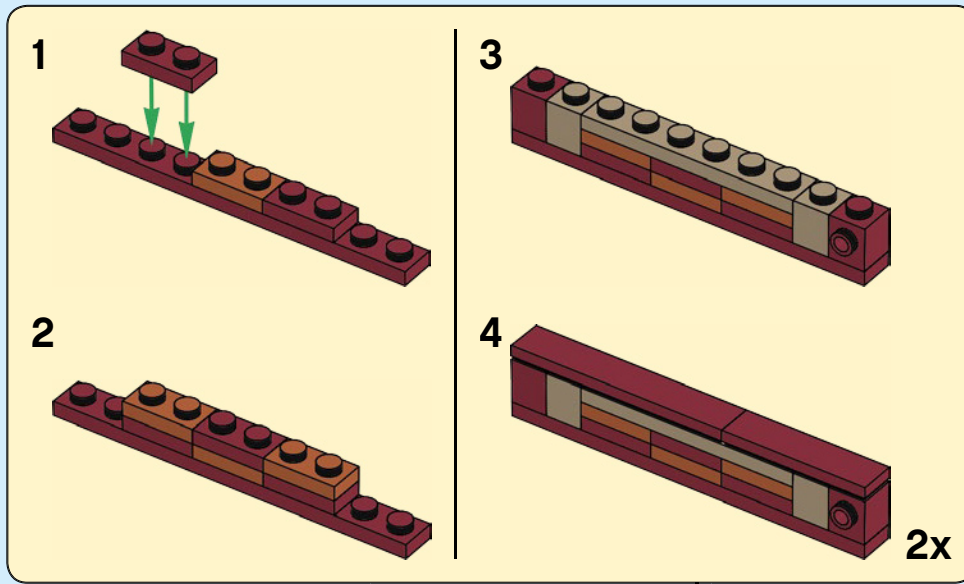

119



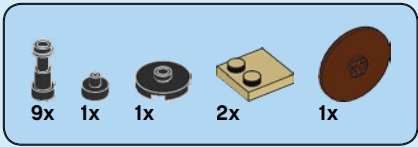

120

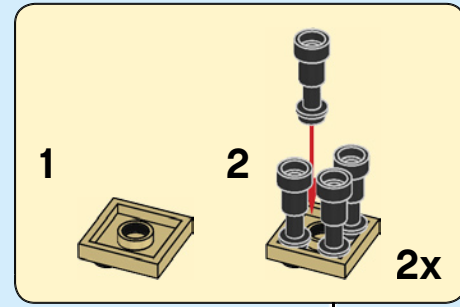
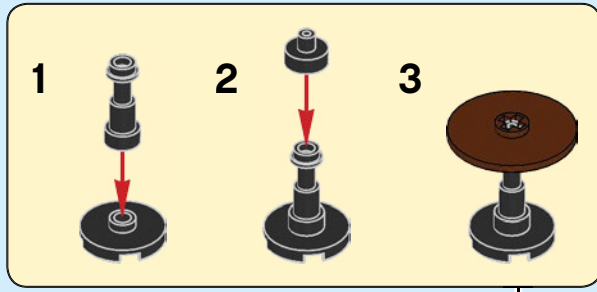

5

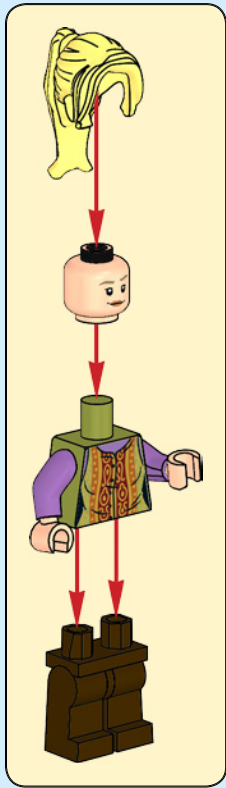
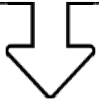

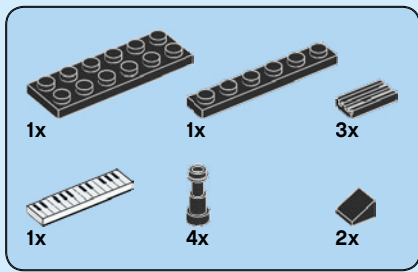

122

1

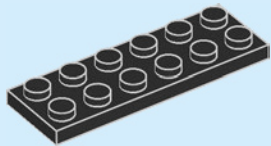

2

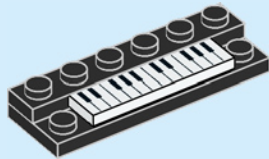

3

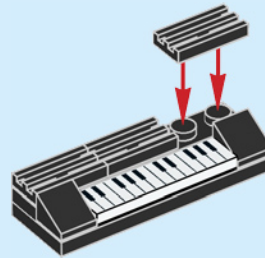

4

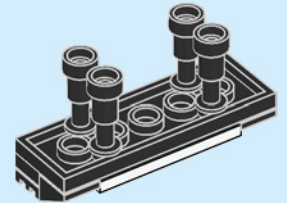
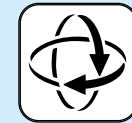

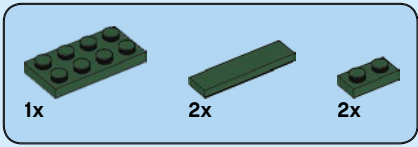

123

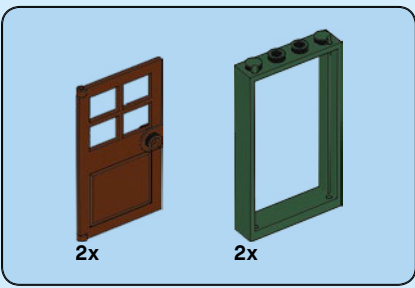
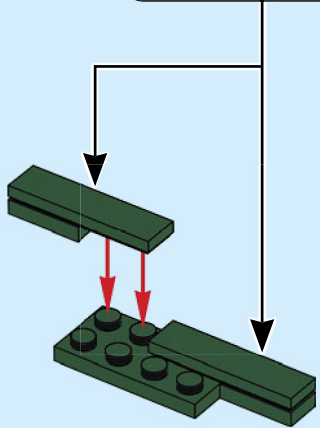
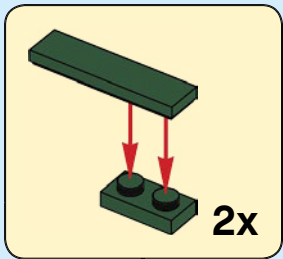

124

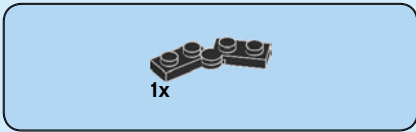
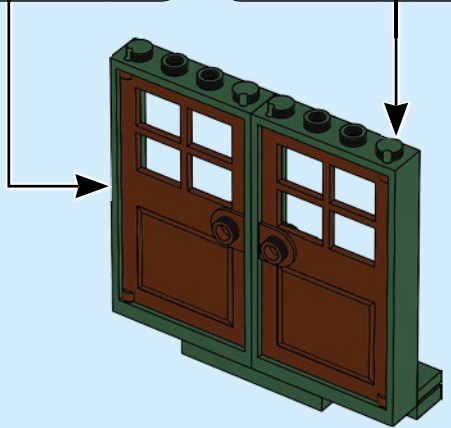
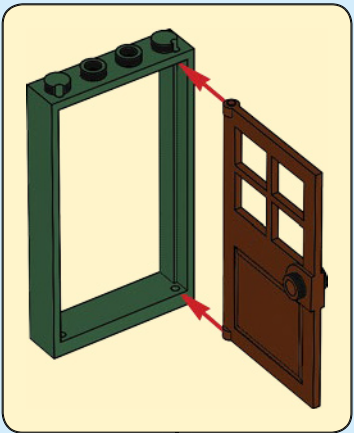
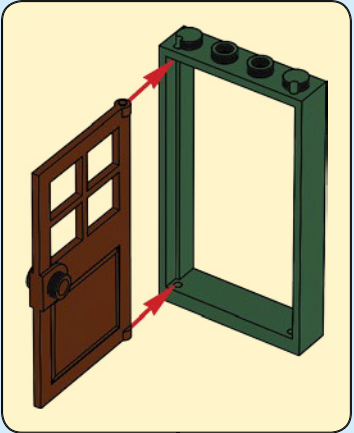

125

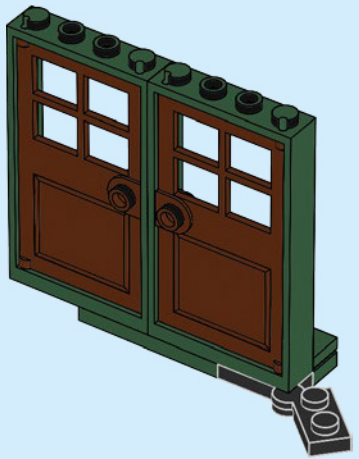

126

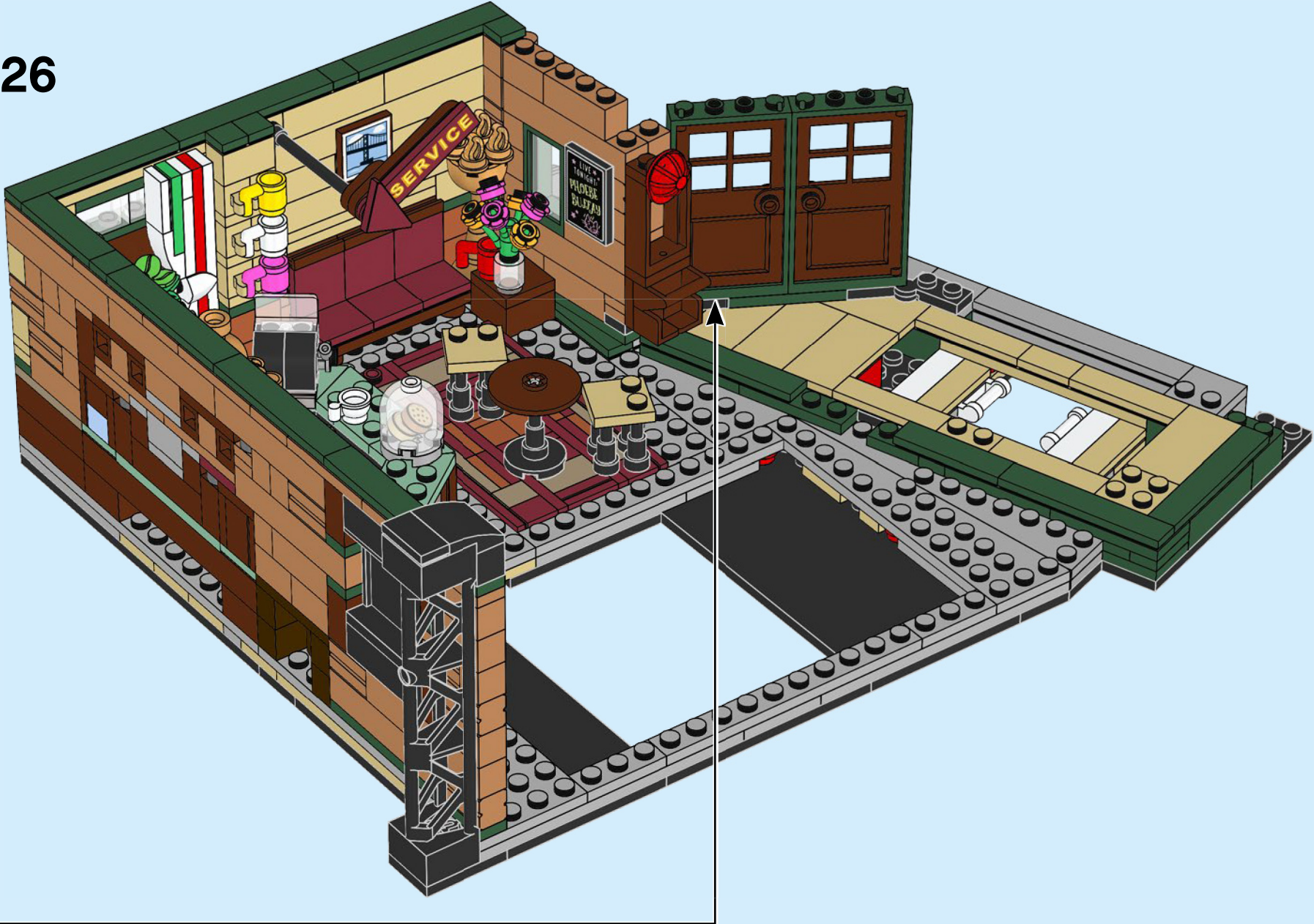

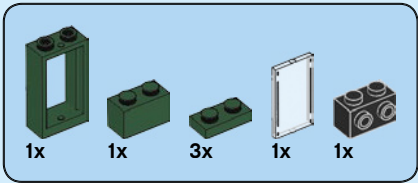

127

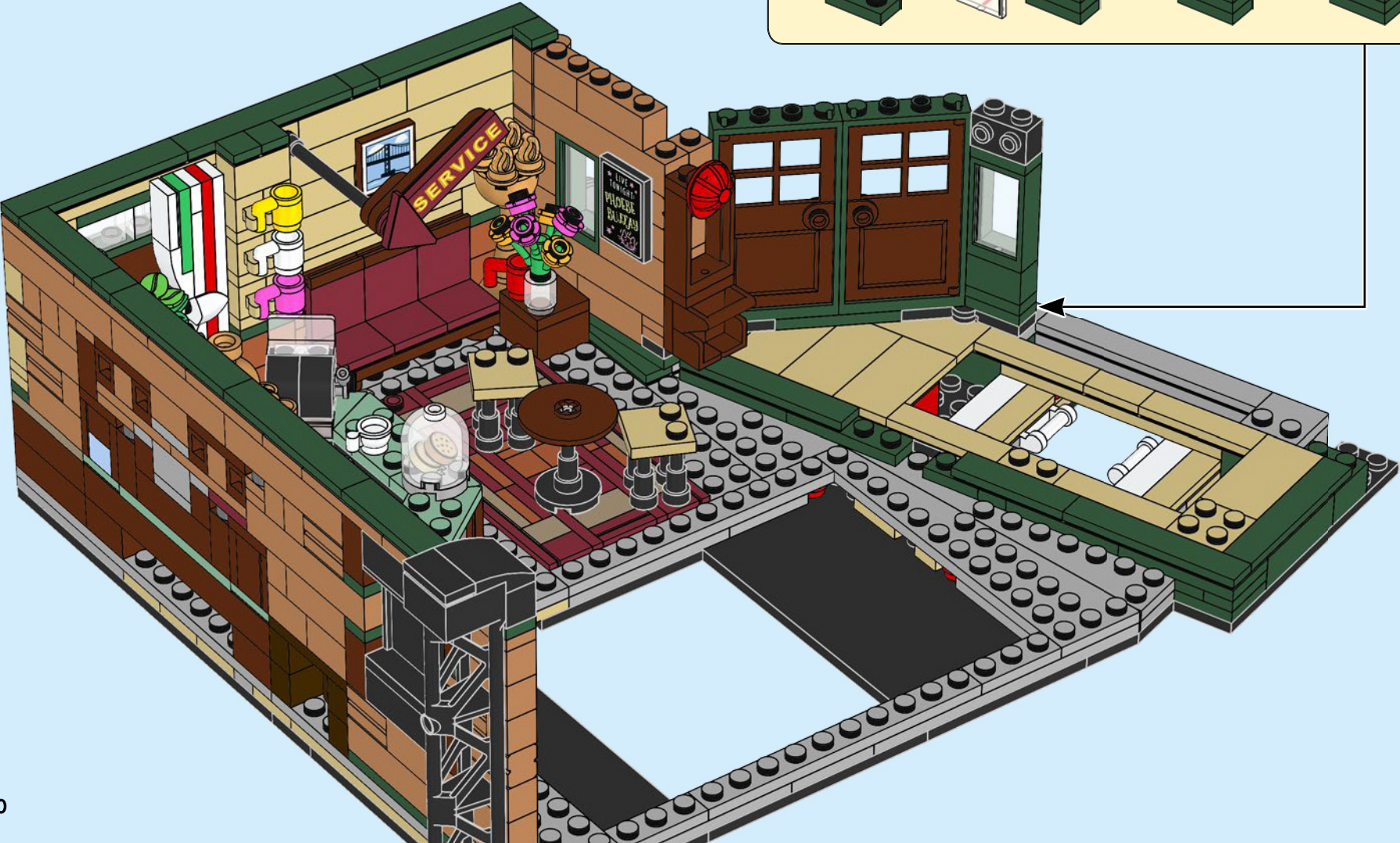
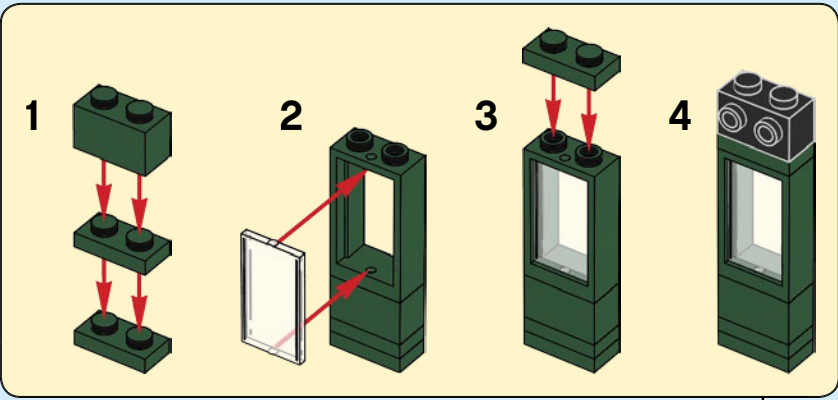

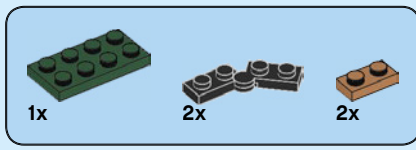

128

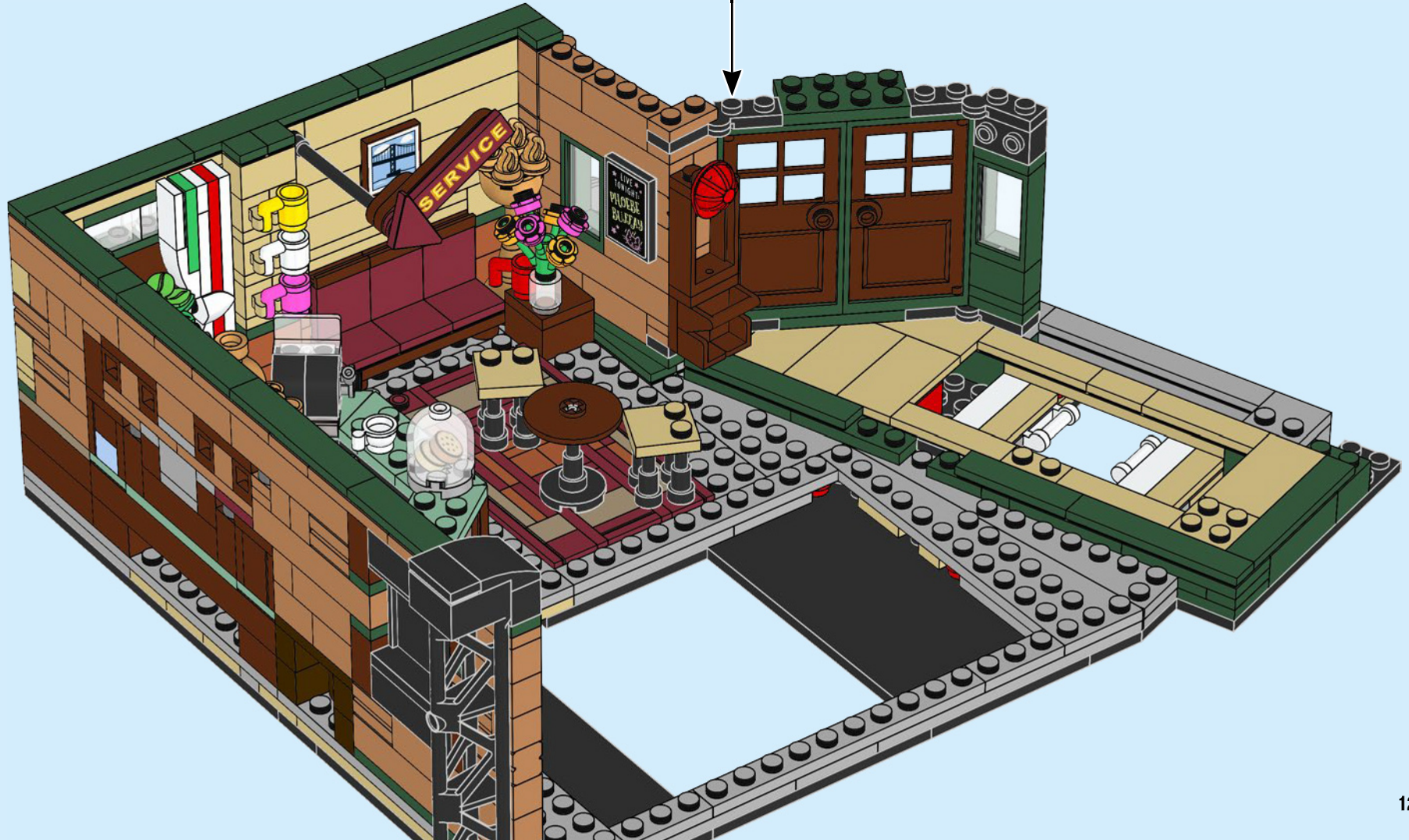
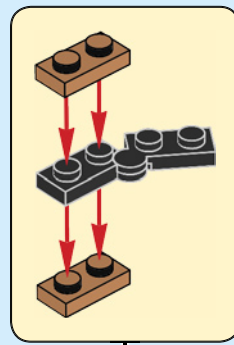

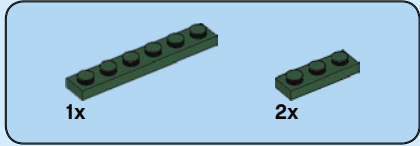

129

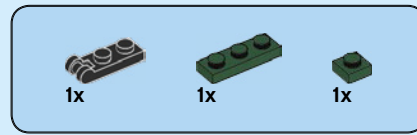
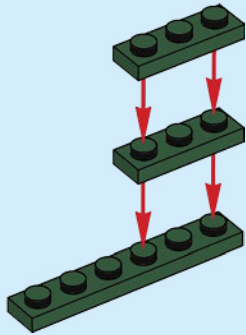

130

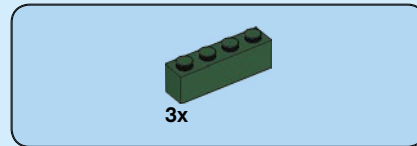
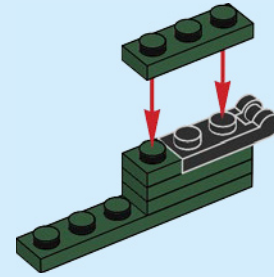

131

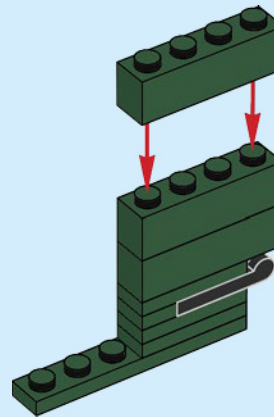

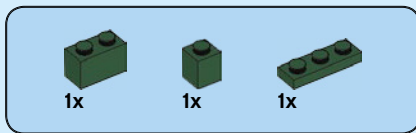

132

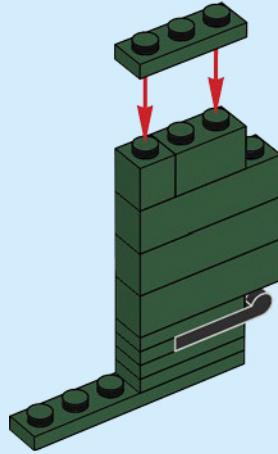

133

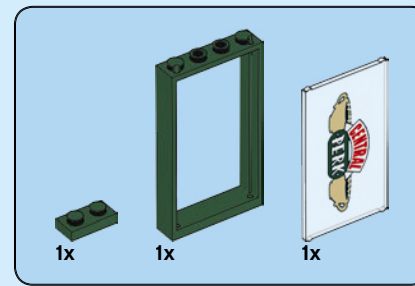
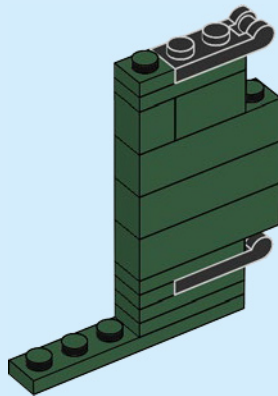

134

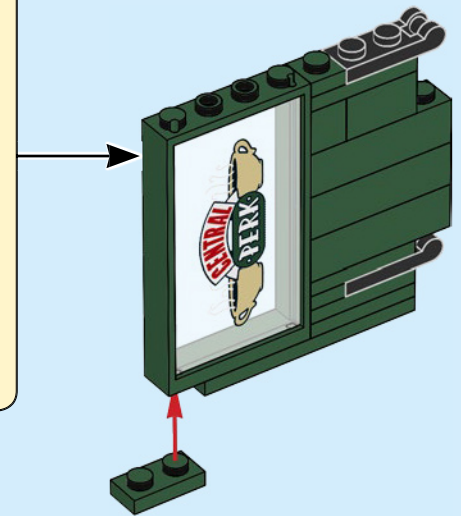
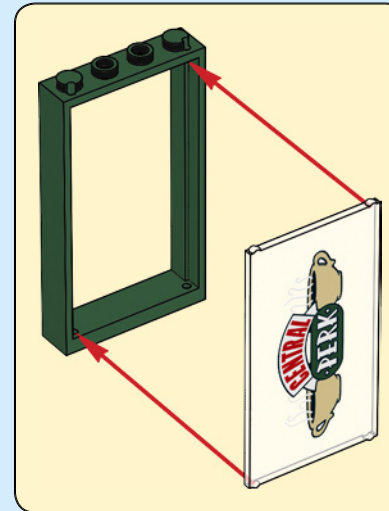



135

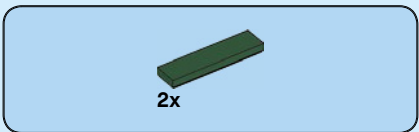
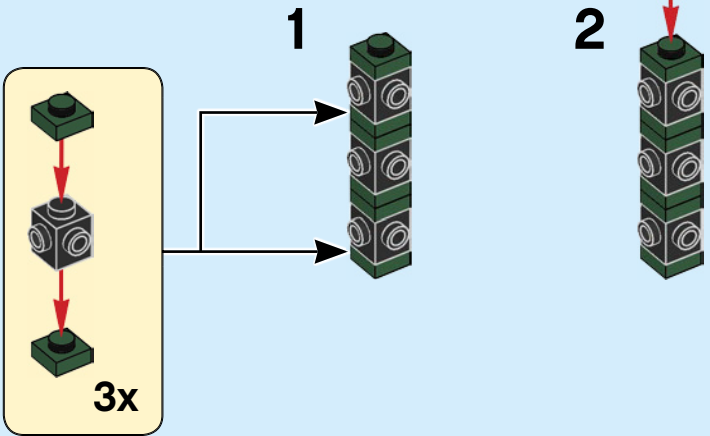

136

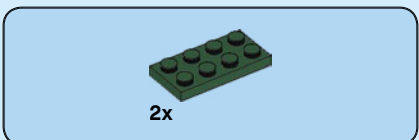
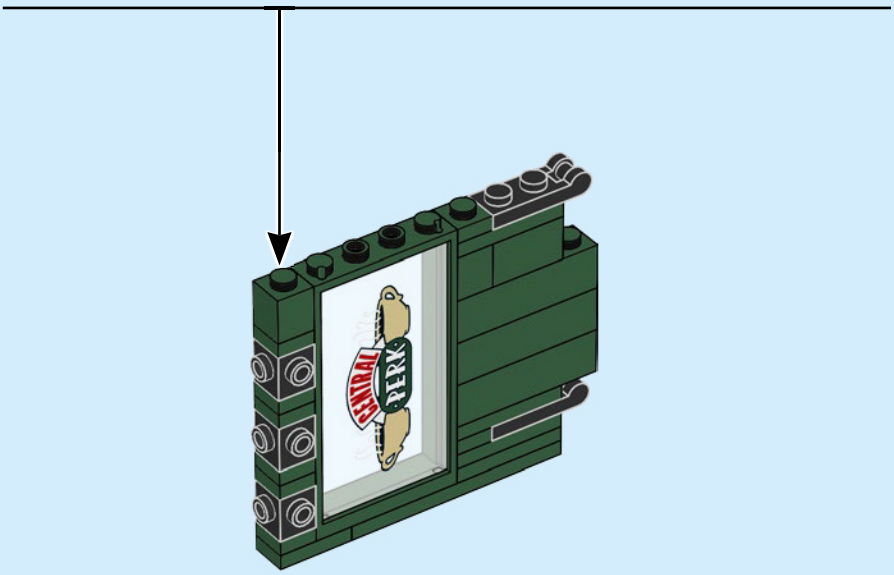
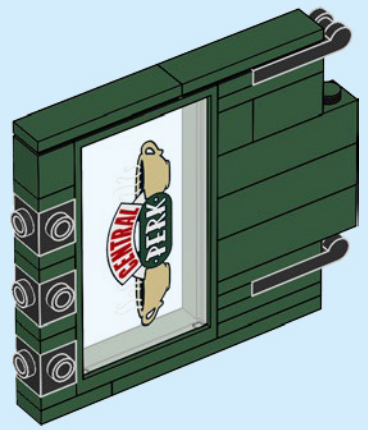

137



138

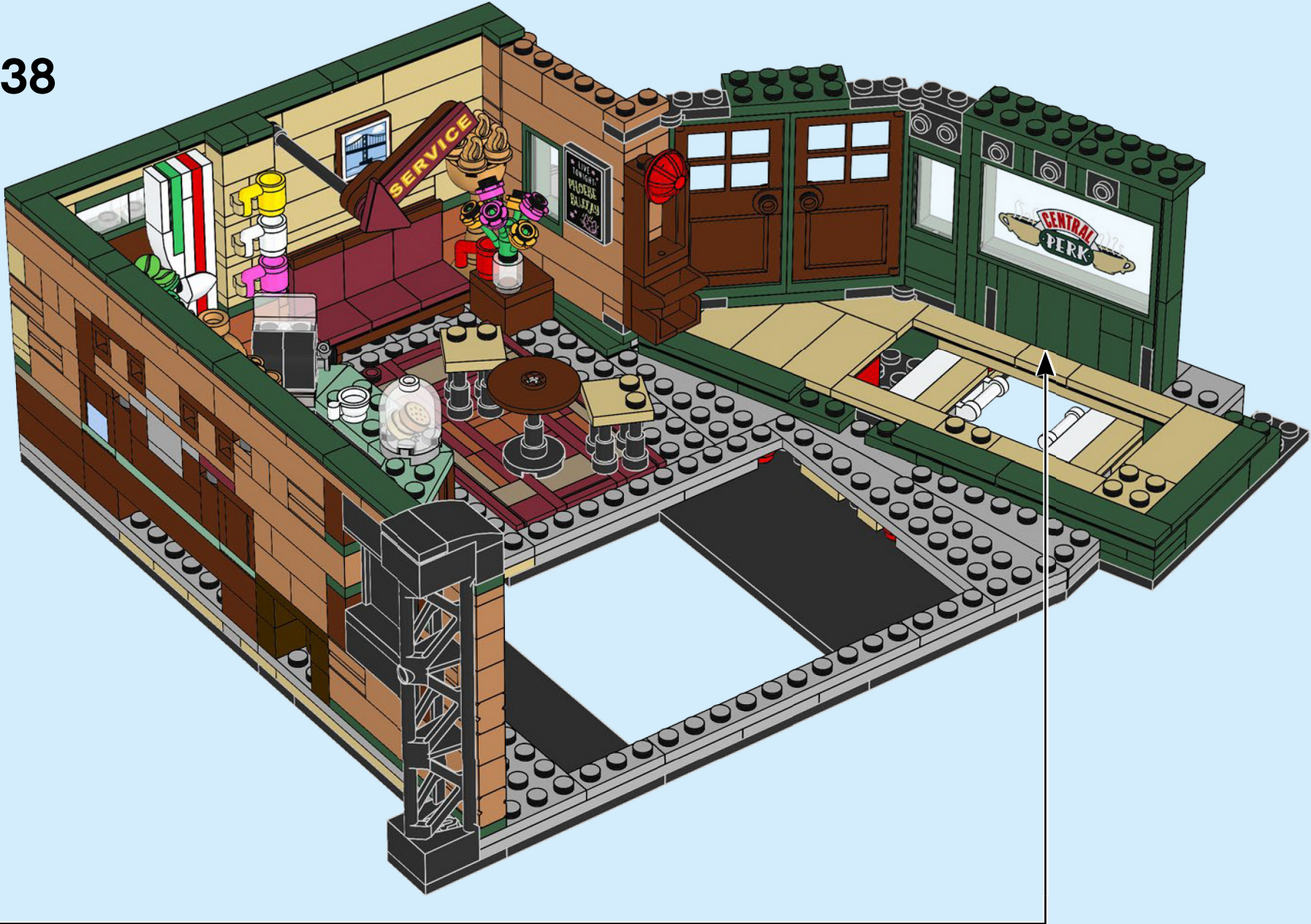

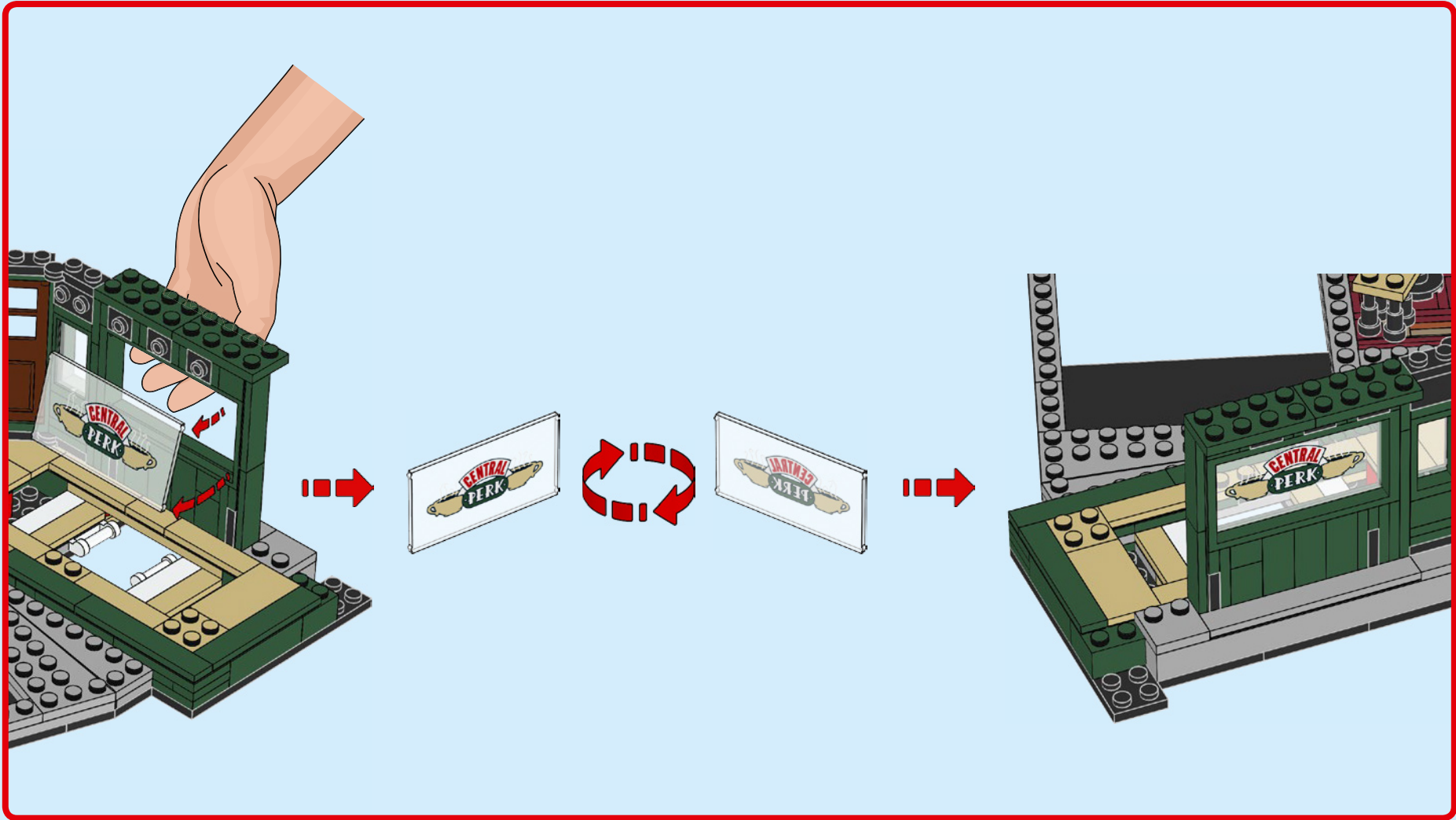

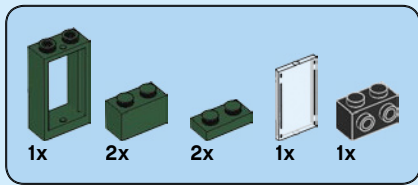

139

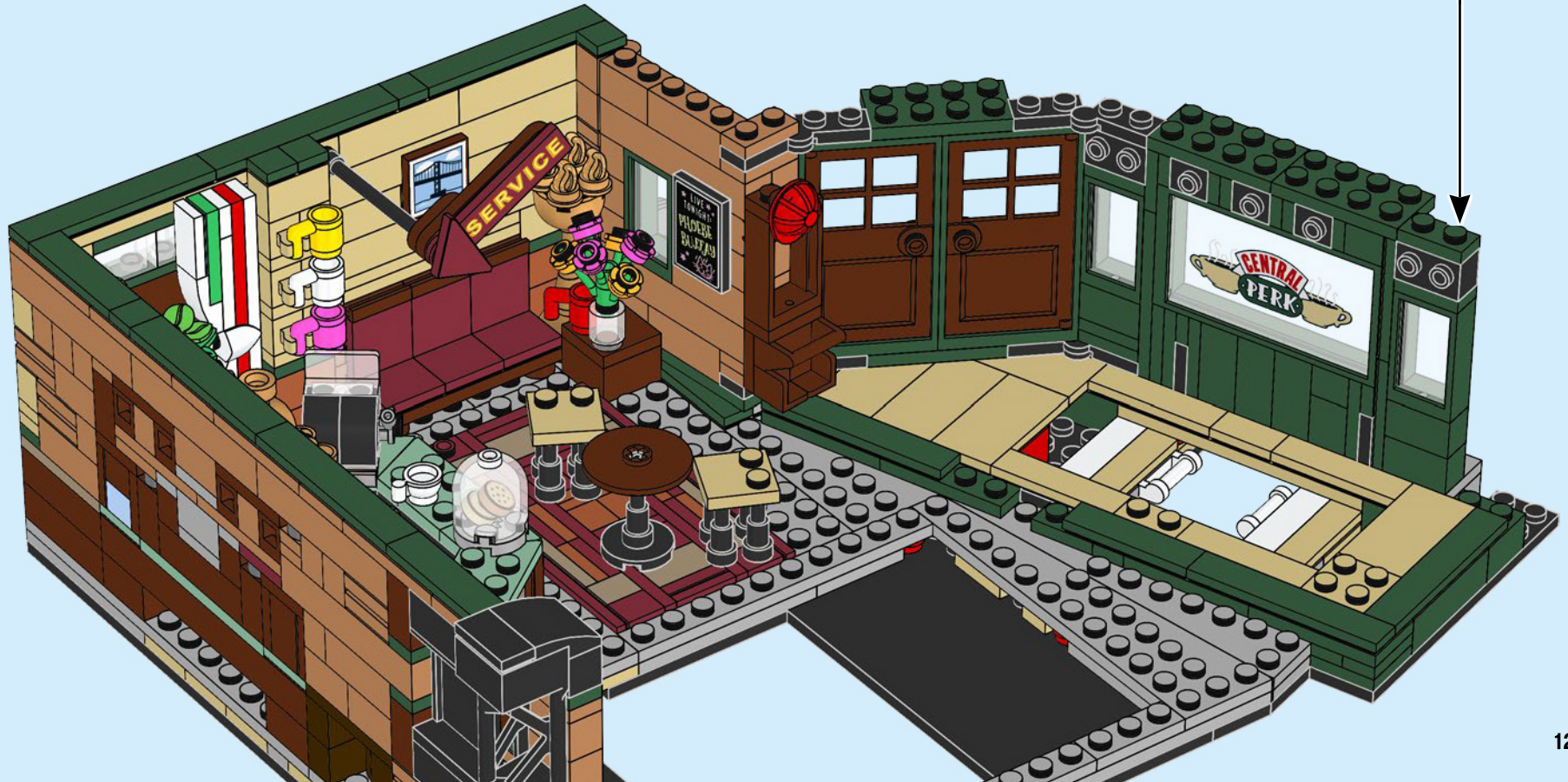
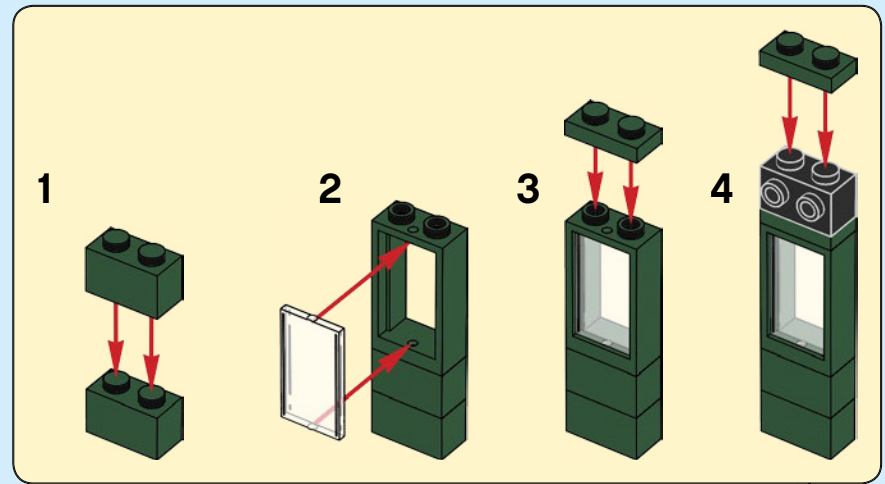



7x



1x

140

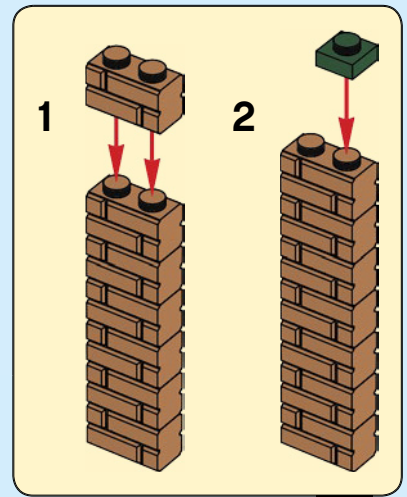

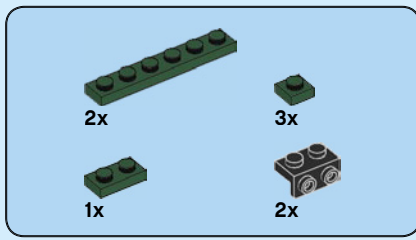

141



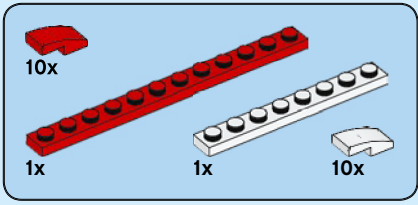

142

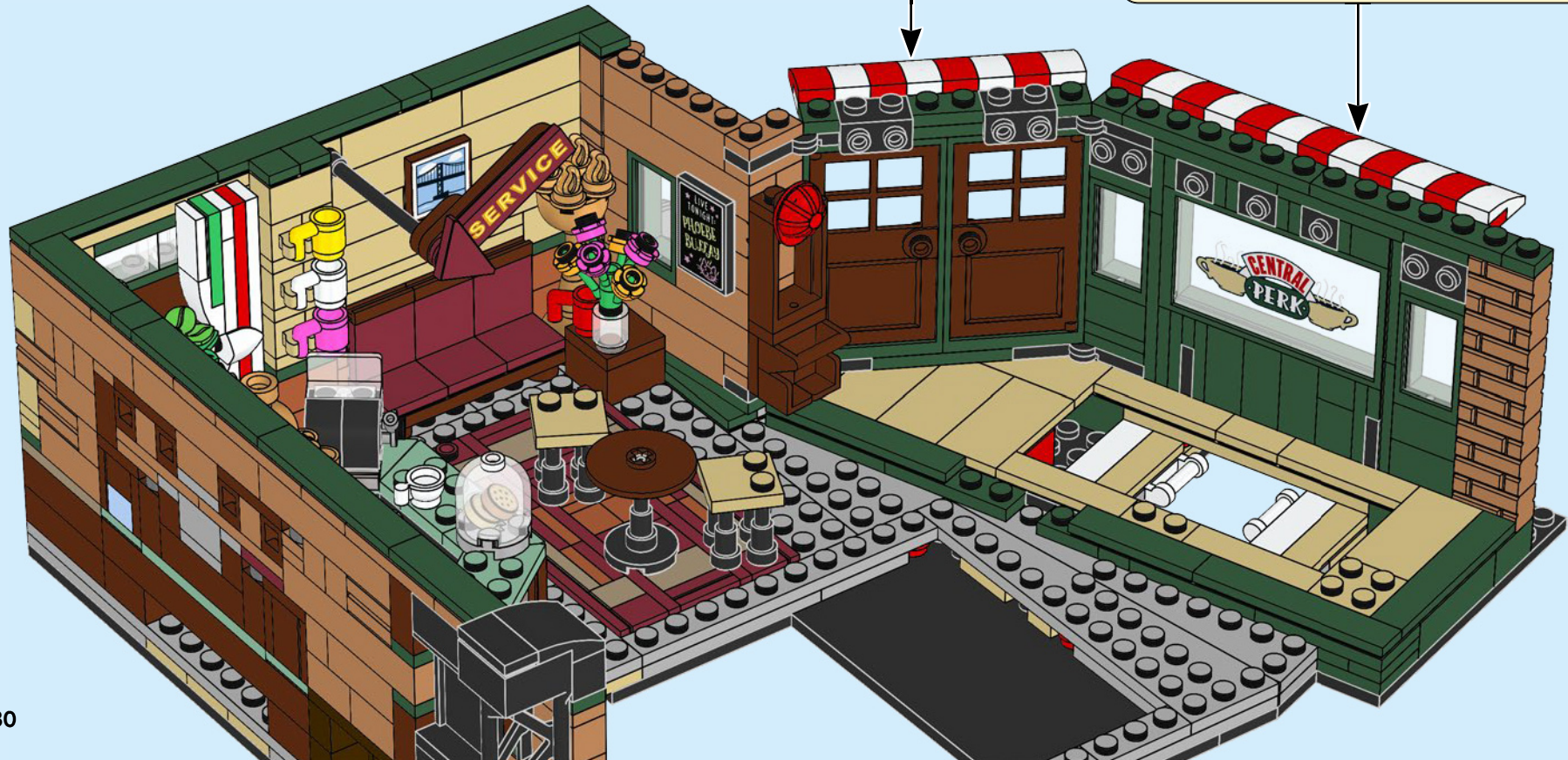
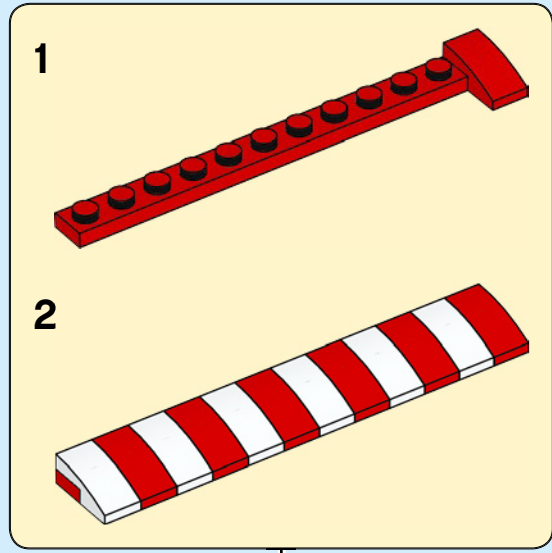
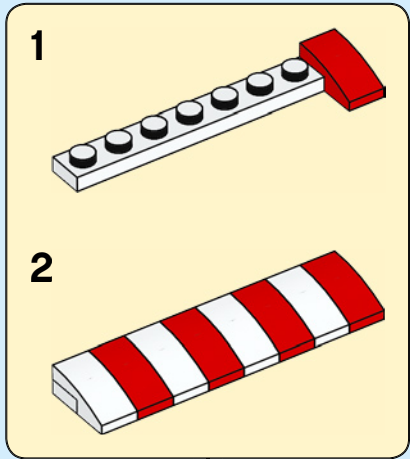

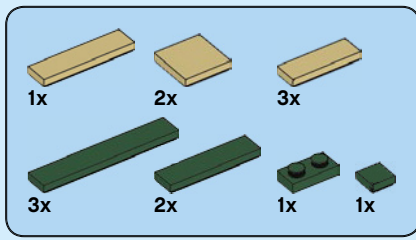

143



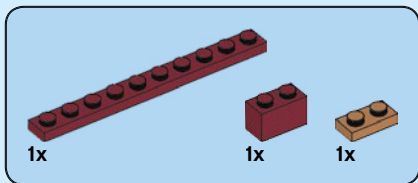

144

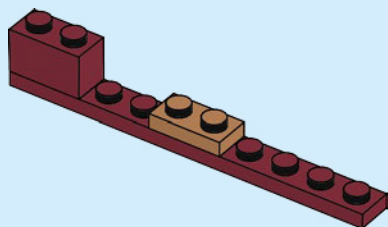

145

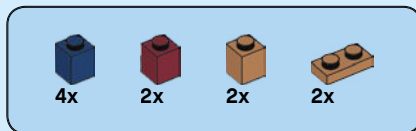
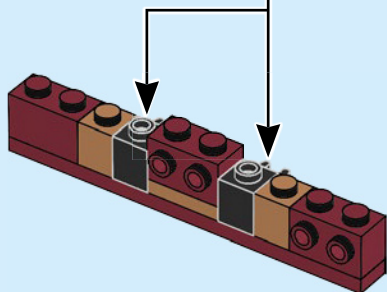

146

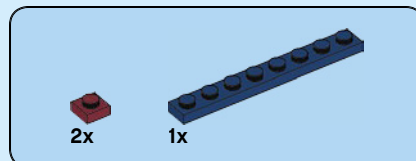
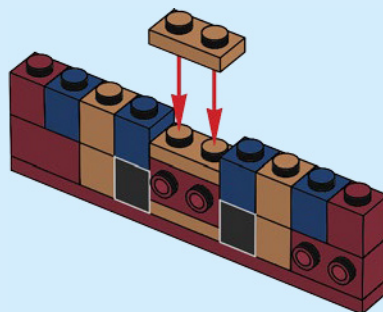

147

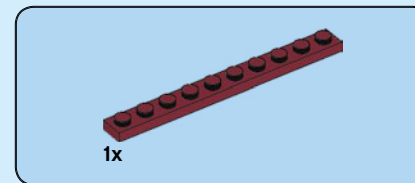
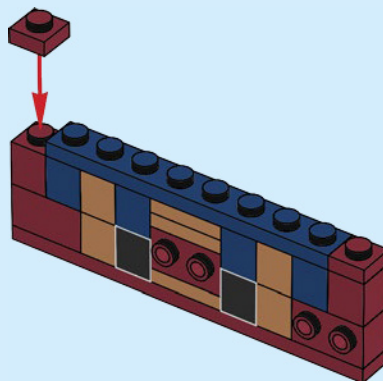

148

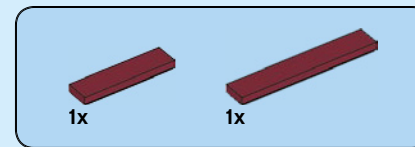
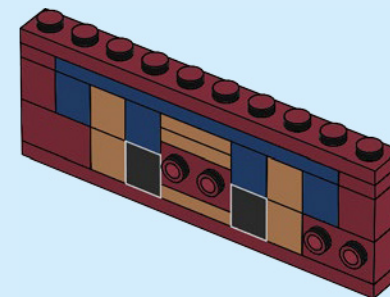

149

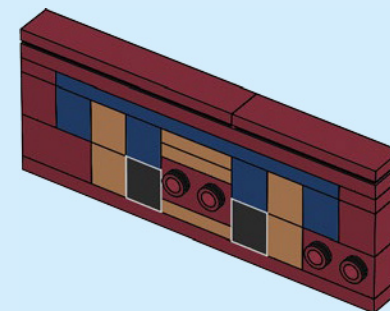

150

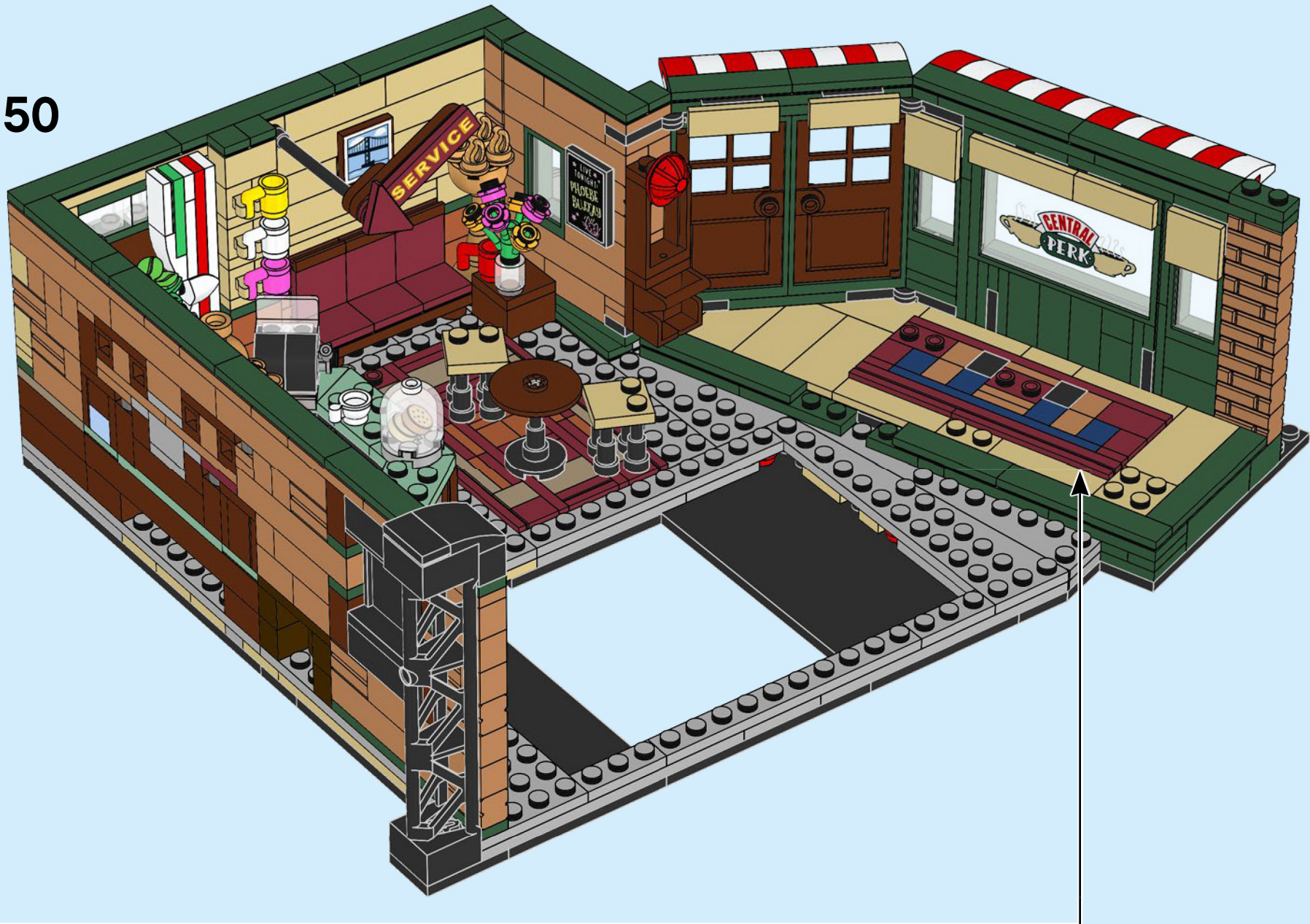



151

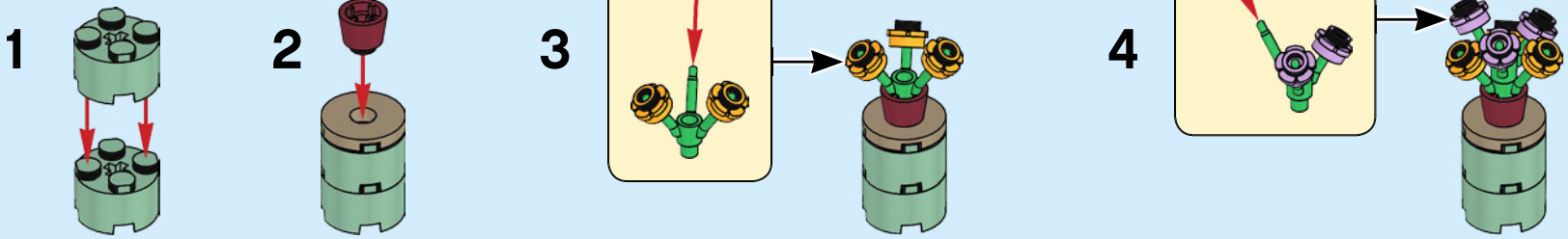

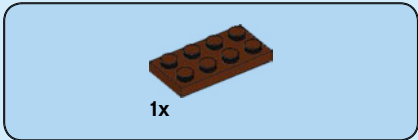

152

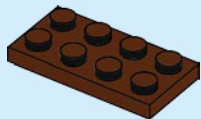

153

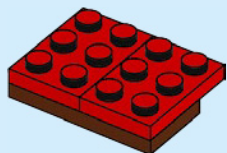

154

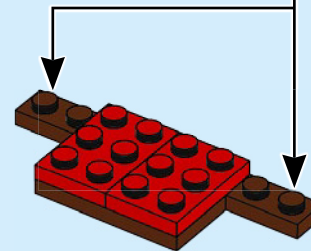
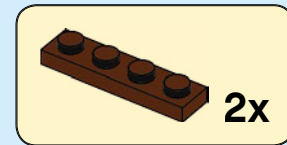

155

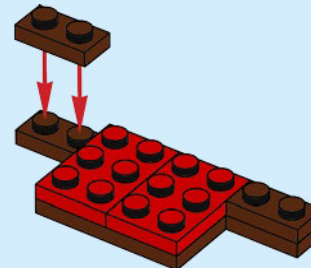

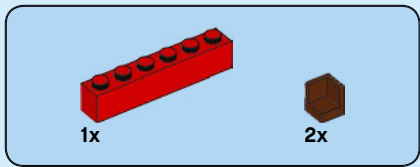

156

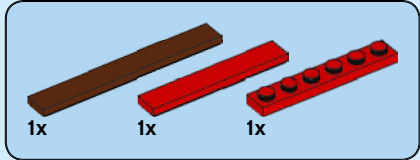
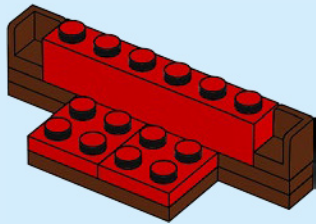

157

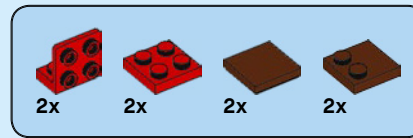
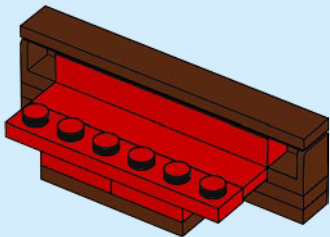

158

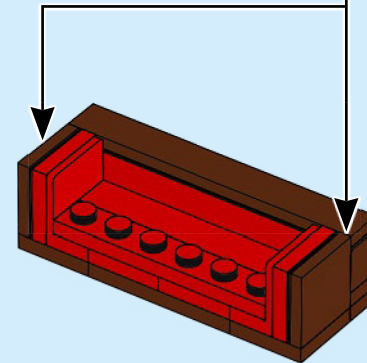
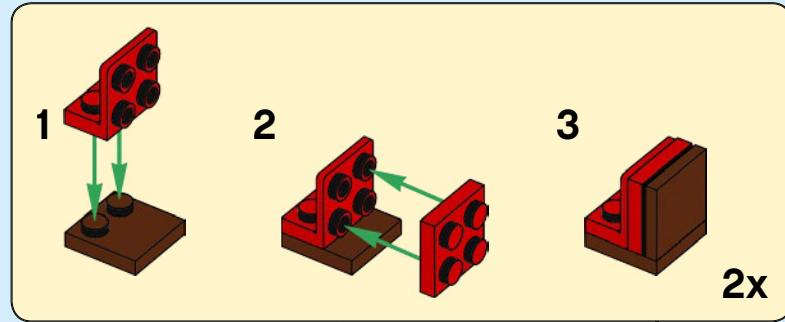

159



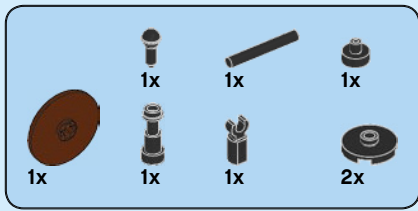

160

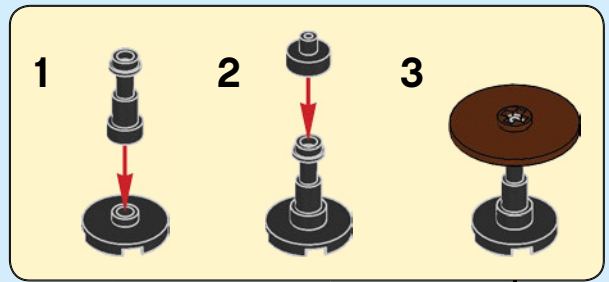
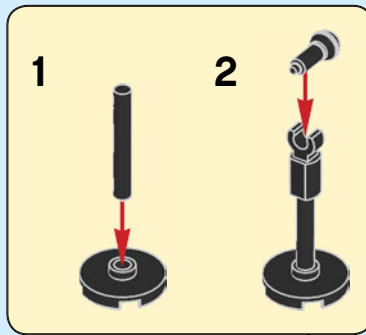

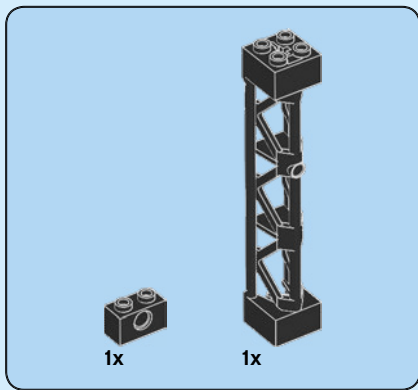

161

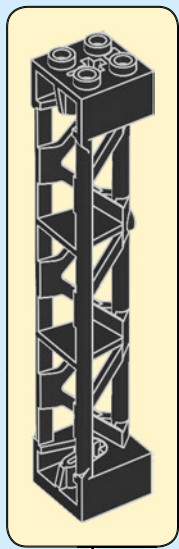

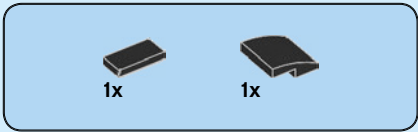

162



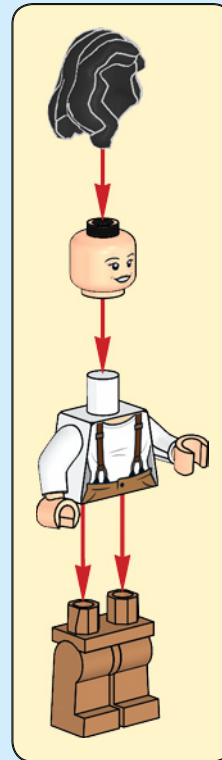

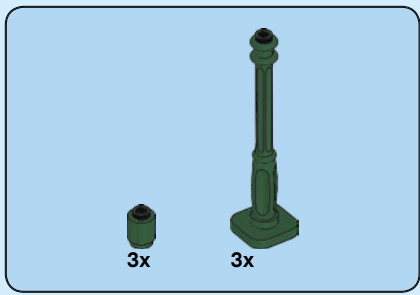

163

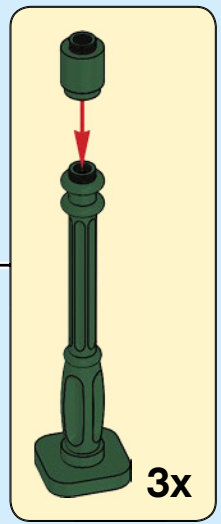

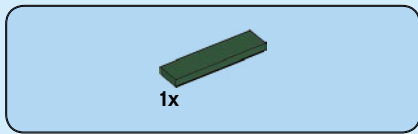

164

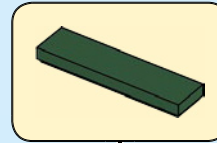

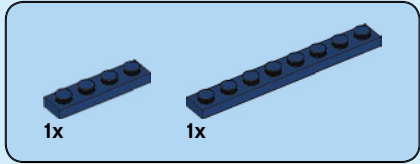
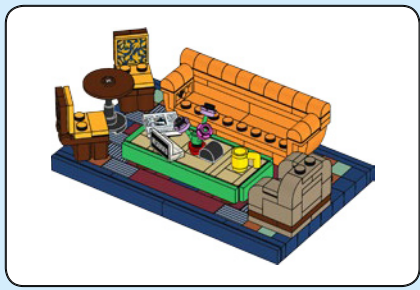

165

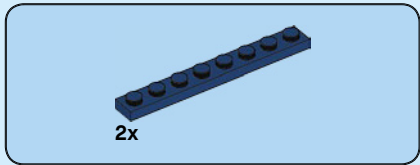
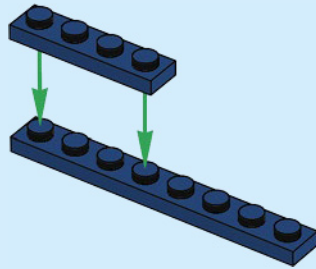

166

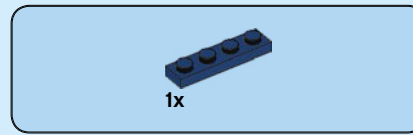
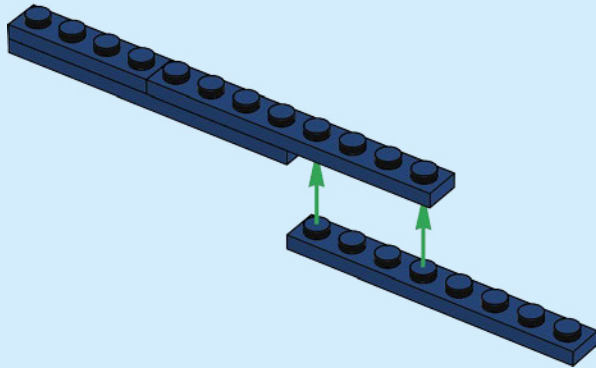

167

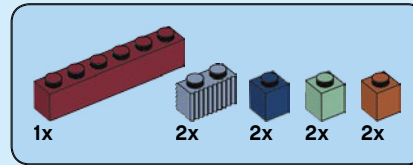
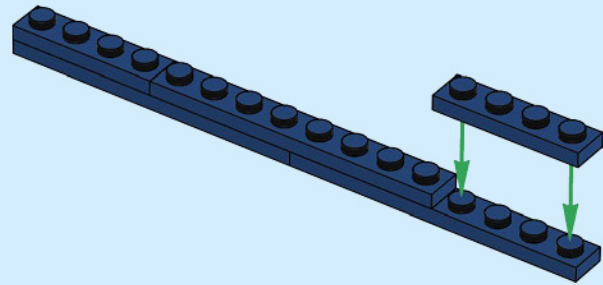

168

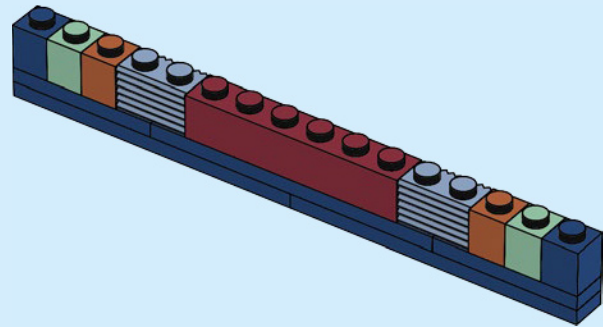

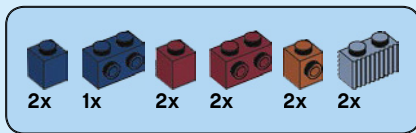

169

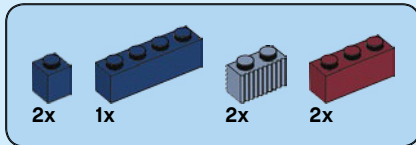
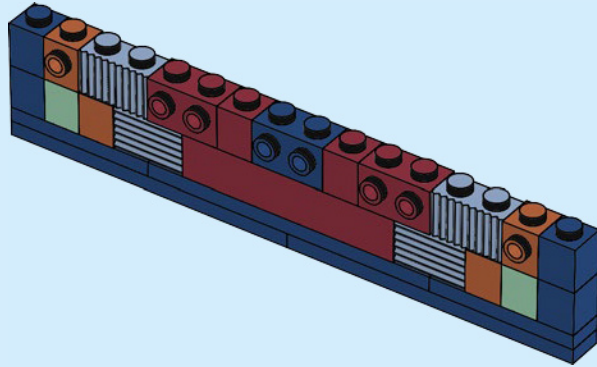

170

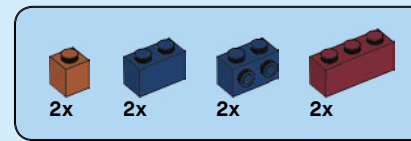
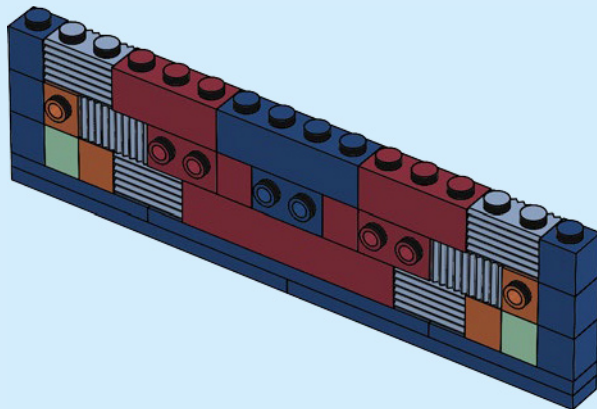

171

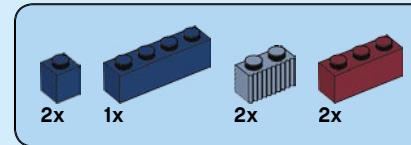
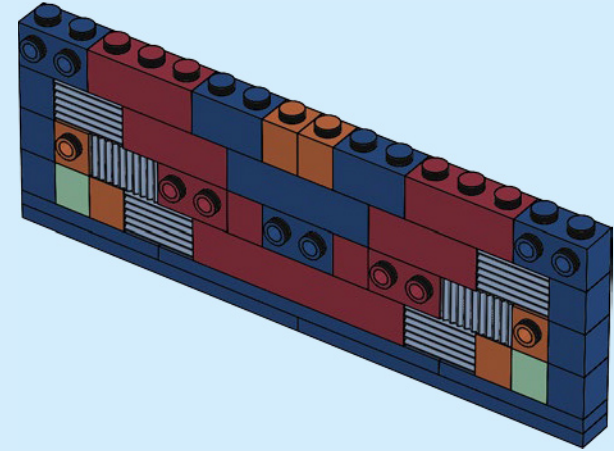

172

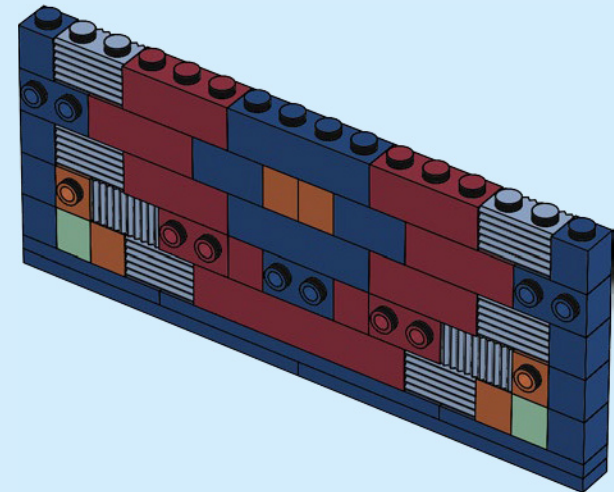

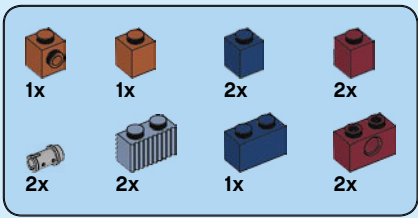

173

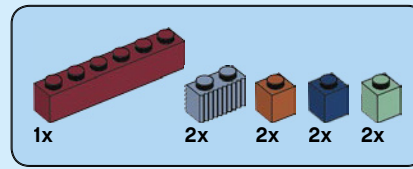
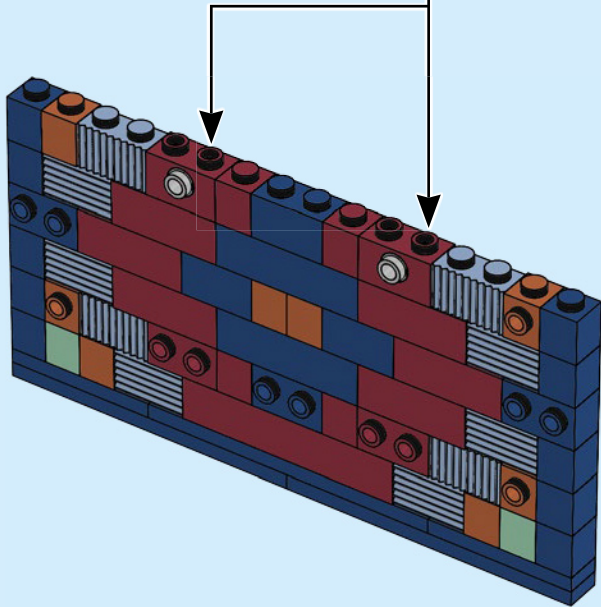
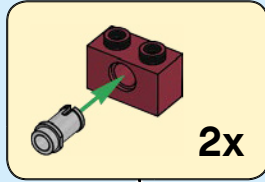

174

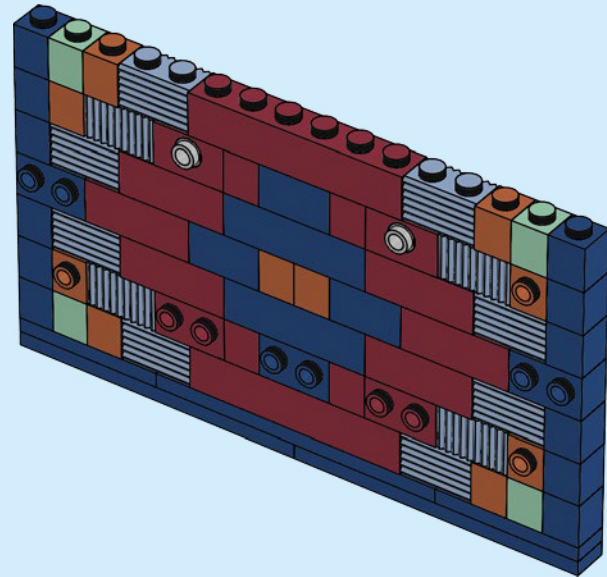

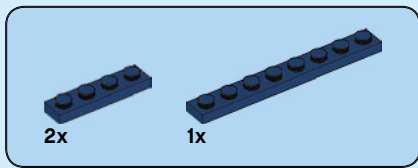

175

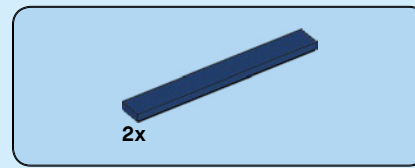
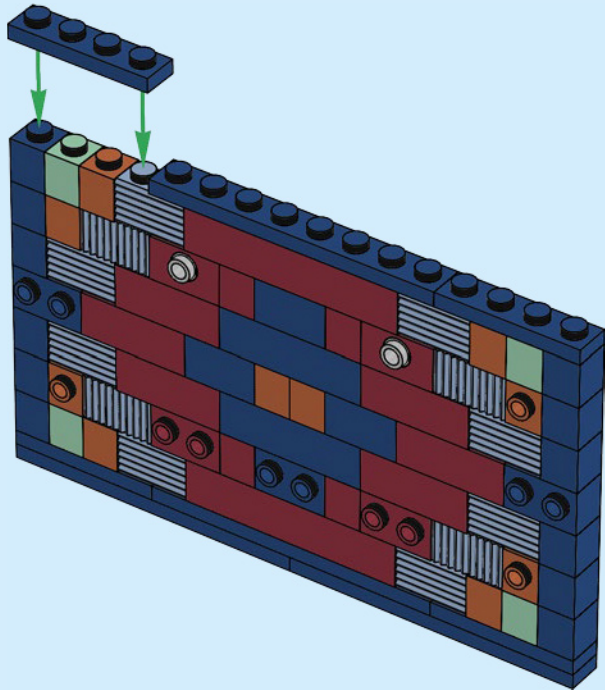

176

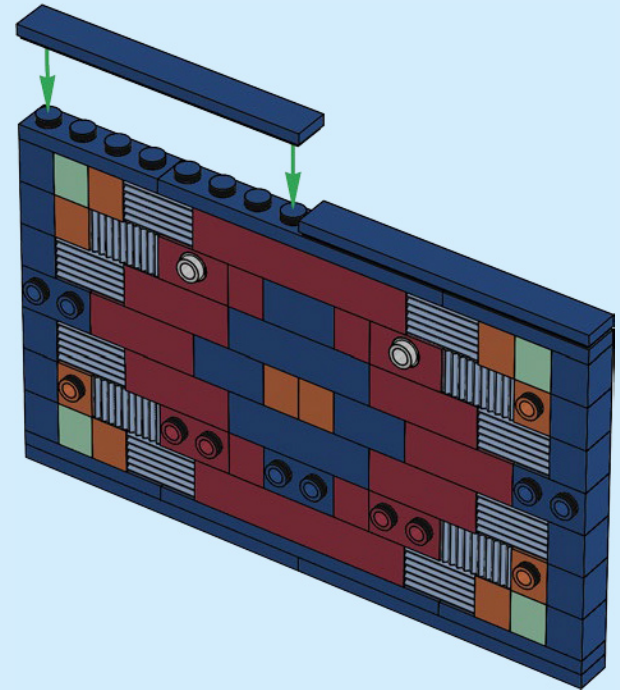

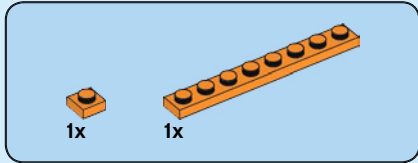
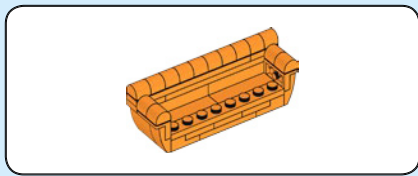

177

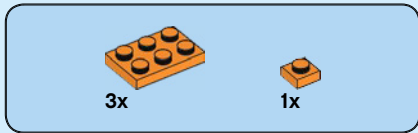
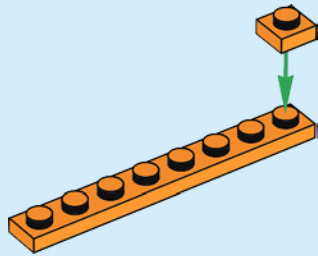

178

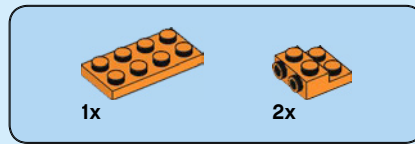
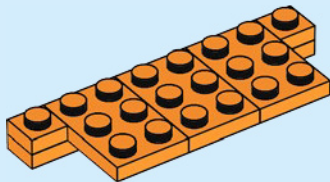

179

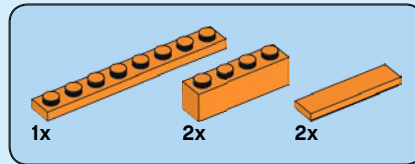
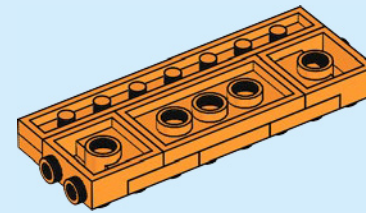
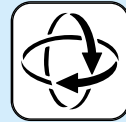

180

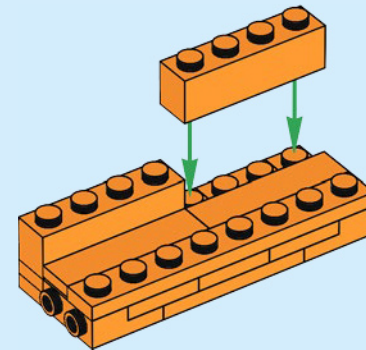
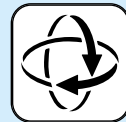

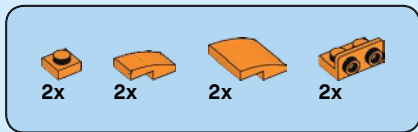

181

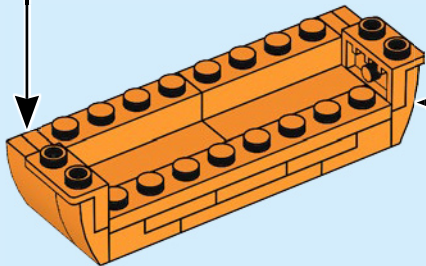
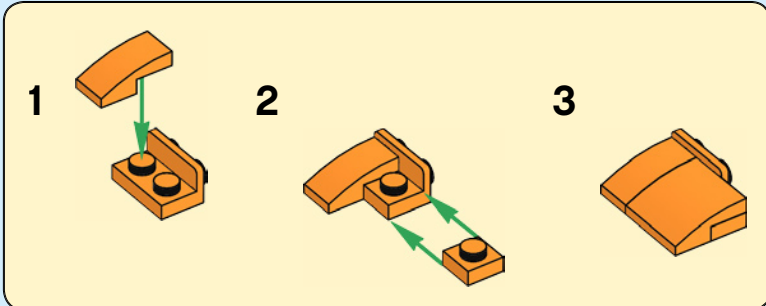
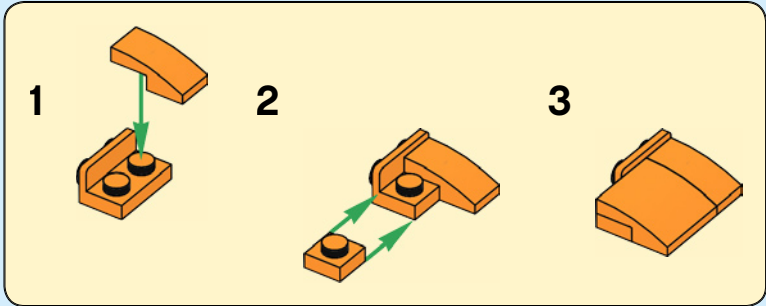

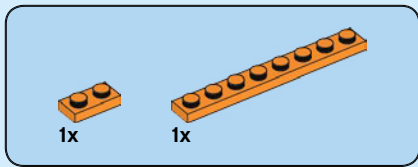

182

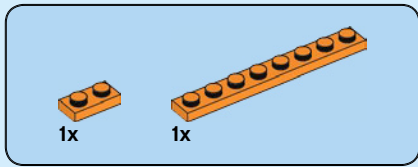
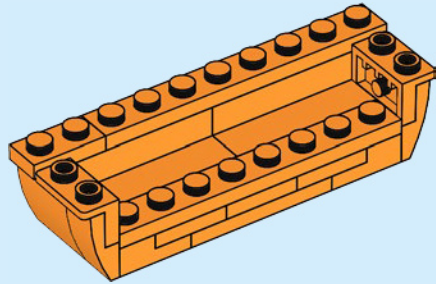

183

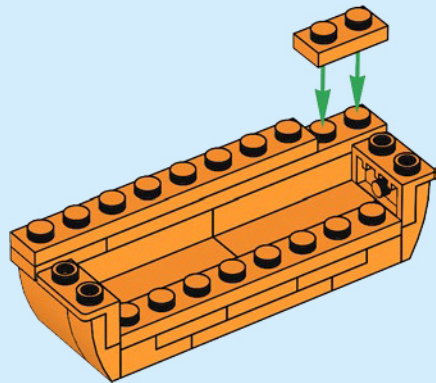

184

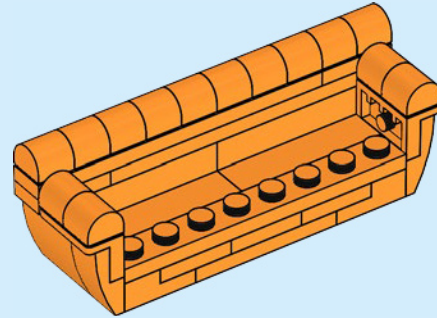

185

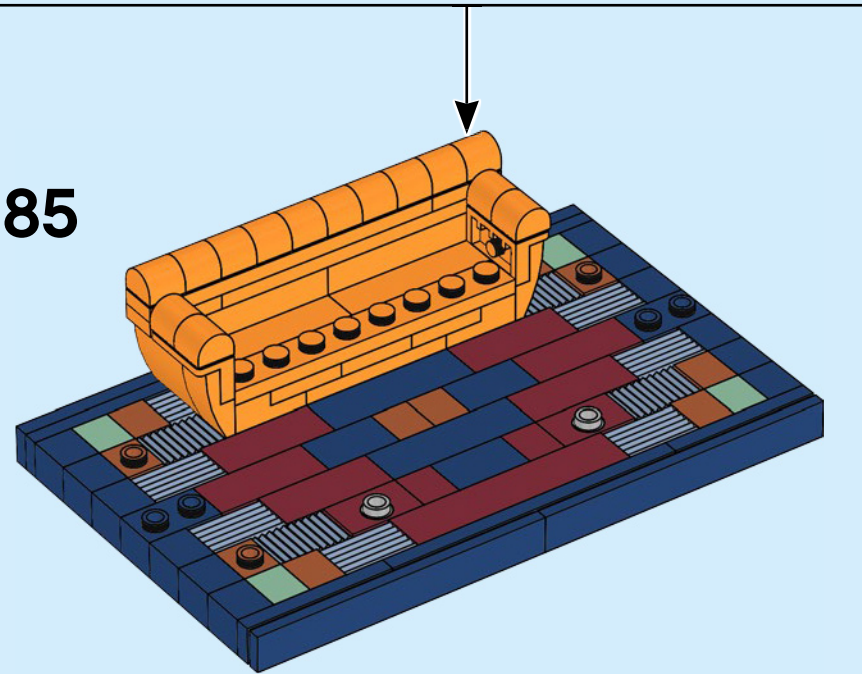

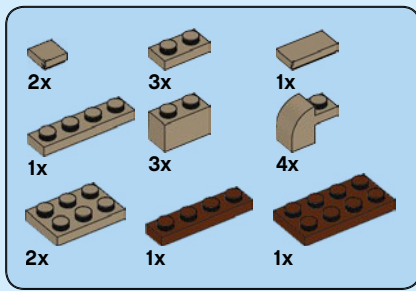

186

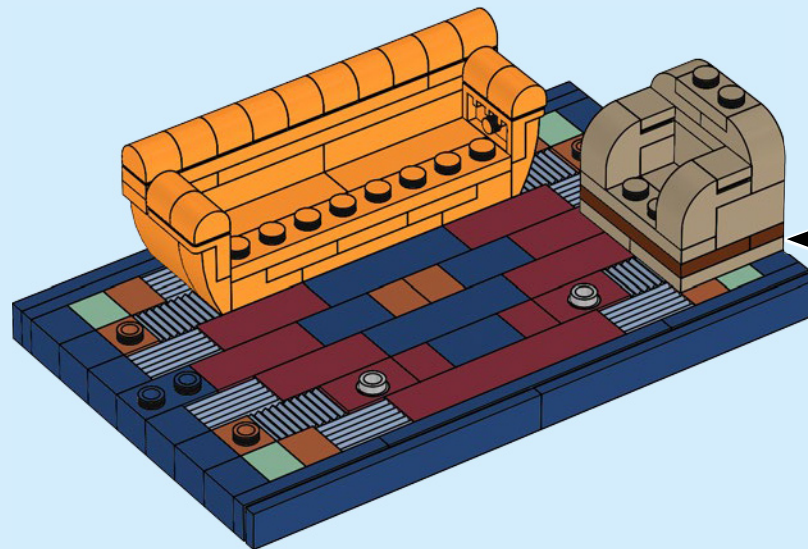
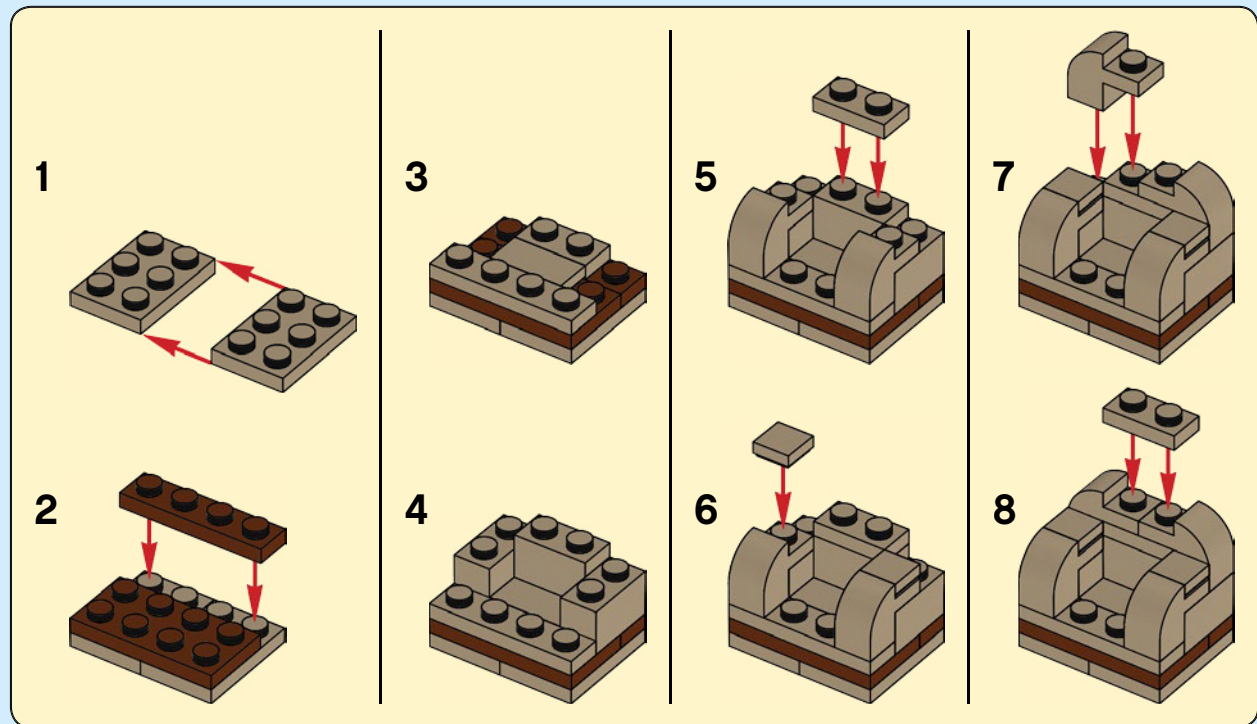

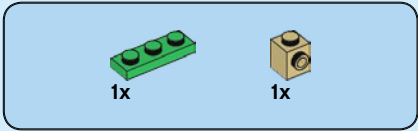
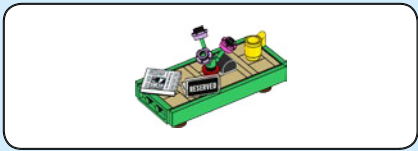

187

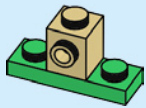

188

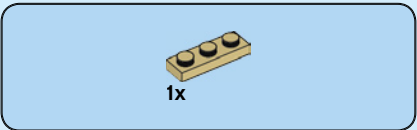
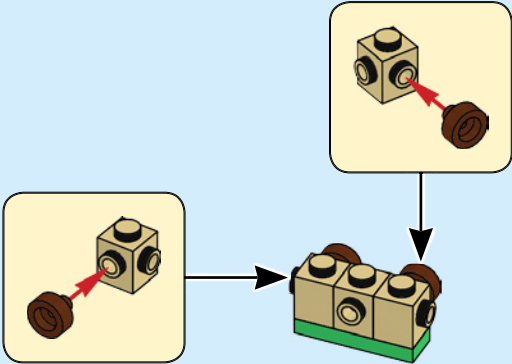

189

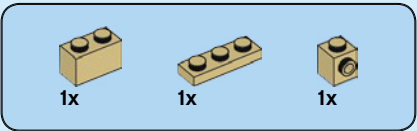
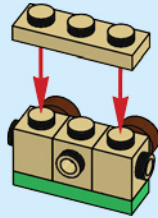

190

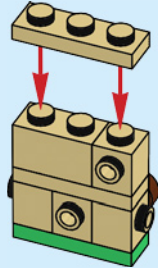

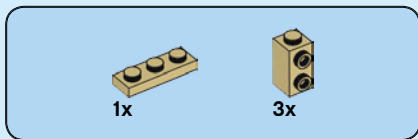

191

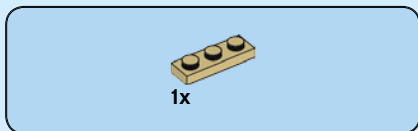
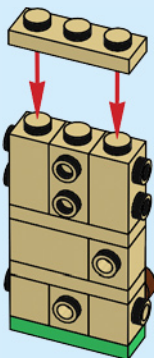

192

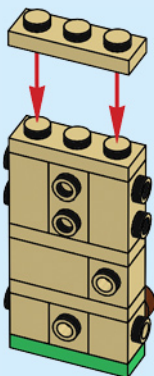

193

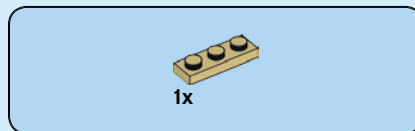
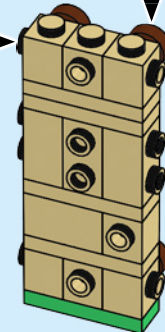
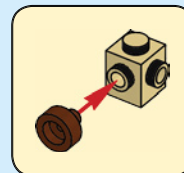
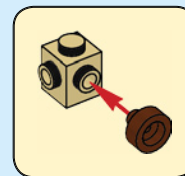

194

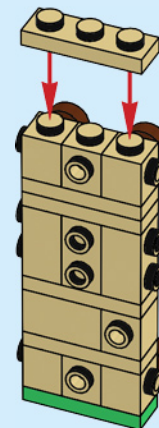

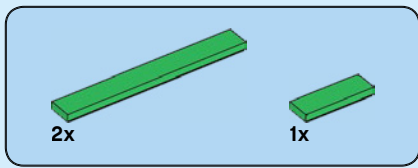

195



196

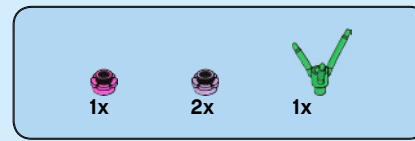
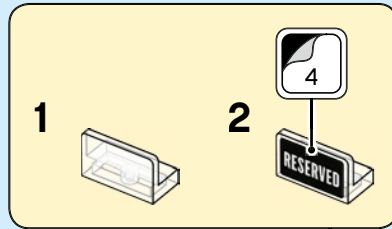
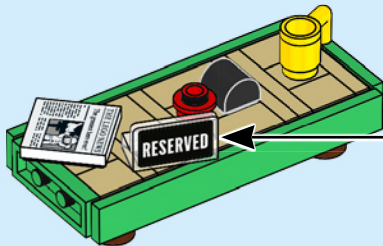

197

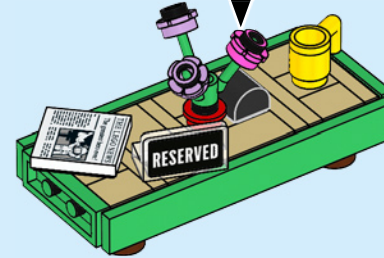
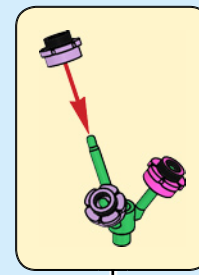

198

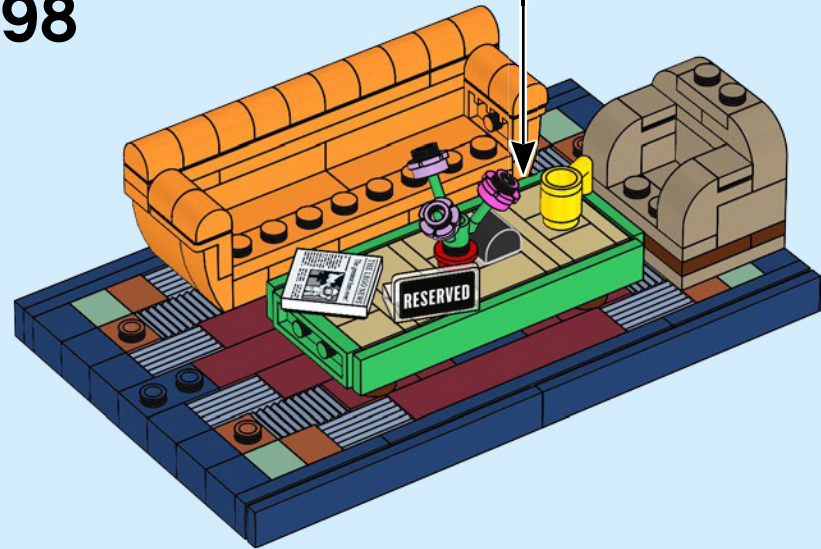

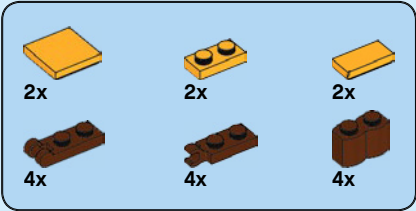

199

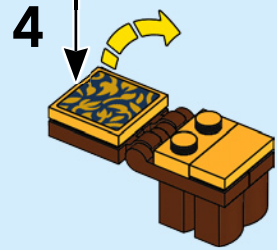
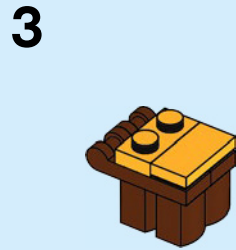
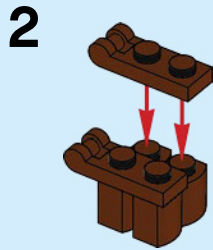
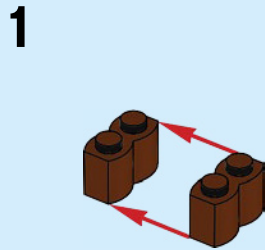
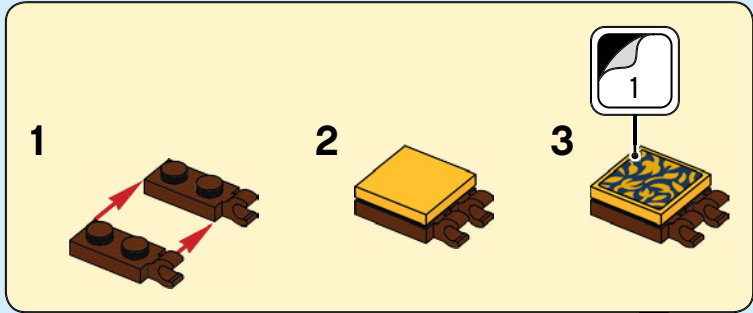

2x

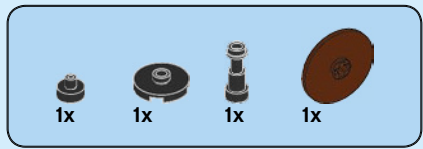

200

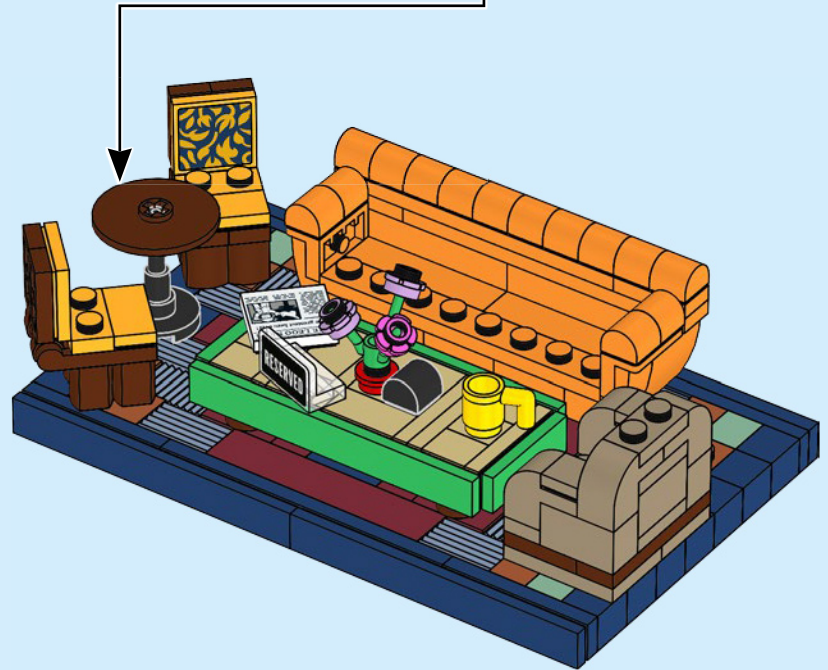
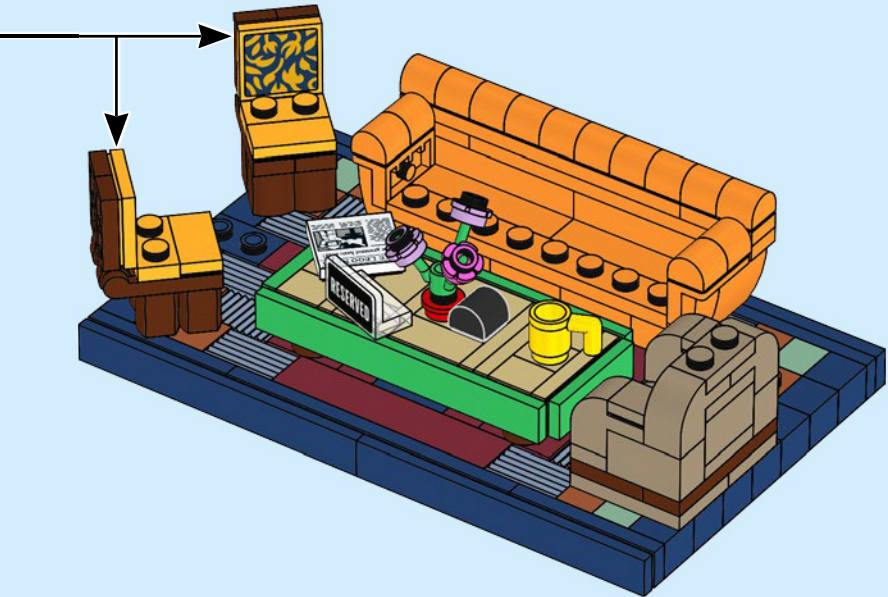
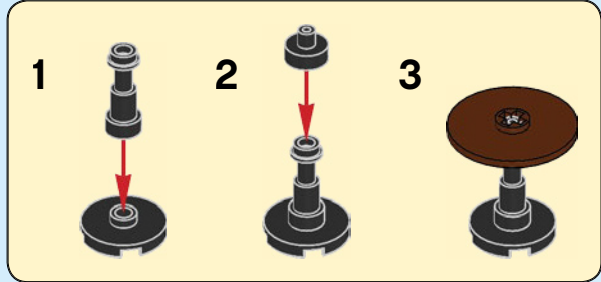

201



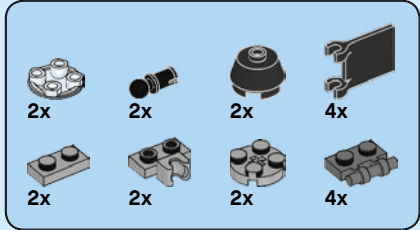
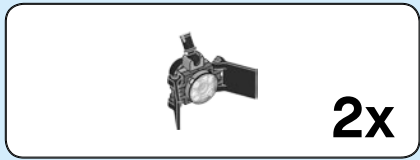

202

1



2

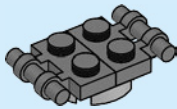

3

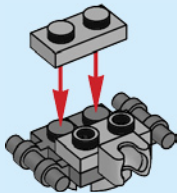

4

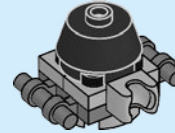

5

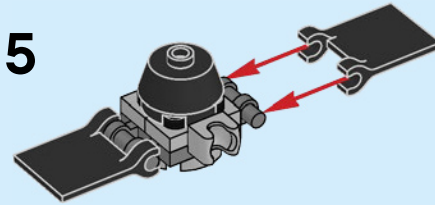

6

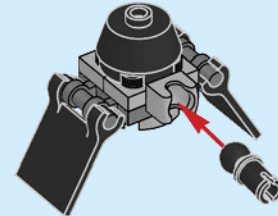

7

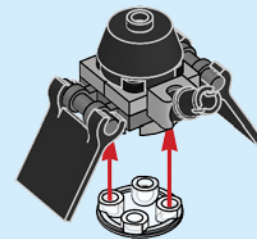

2x



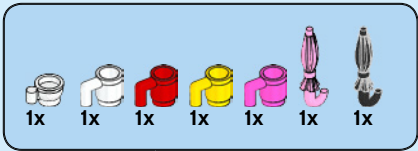

203





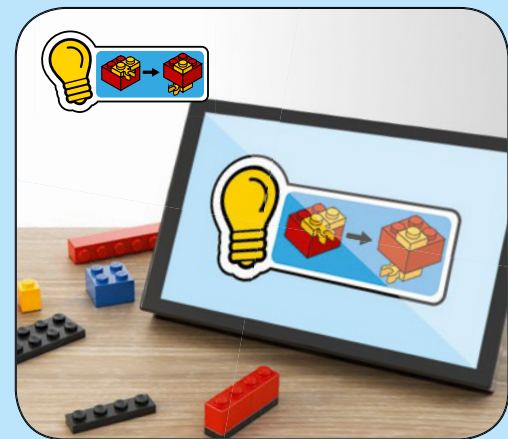

3x 6235083
 1x 307001
 1x 6046905
 2x 4659665
 1x 6037640
 1x 4538353
 1x 306901
 12x 6034044
 2x 4222017
 1x 6218212
 1x 6175184
 1x 362301
 1x 6156667
 1x 6284099
 2x 663601
 2x 346001

1x 6285621
 2x 4159553
 4x 4579260
 1x 6175469
 5x 4113915
 3x 6232135
 1x 6170568
 4x 6175968
 3x 6136390
 3x 4109995
 4x 6024495
 2x 4114026
 13x 4113917
 4x 6102772
 2x 6221467

3x 4114084
 2x 4185177
 1x 4114306
 1x 4162465
 3x 6131896
 5x 4121921
 7x 4550324
 4x 4113916
 5x 6122047
 3x 4124067
 1x 4112982
 2x 4114324
 4x 4249019

2x 6075179
 1x 6030980
 1x 4514843
 1x 6223427
 8x 614121
 1x 4558886
 2x 389921
 1x 383321
 2x 4597713
 10x 6029946
 1x 241221
 2x 6001806
 2x 302221
 2x 302121

1x 4113858
 1x 300921
 1x 366621
 1x 4181138
 1x 346021
 3x 4143005
 3x 389924
 1x 6170421
 1x 6088550
 15x 4538456
 1x 6015891
 1x 306226
 3x 6186675

1x 6171840
 2x 4504382
 1x 6273589
 1x 4558954
 1x 300526
 3x 6187572
 1x 4214559
 1x 6134617
 2x 4184169
 1x 6079896
 1x 6196548
 2x 4533771
 1x 4180508
 2x 4653822
 4x 6195325
 1x 4610232

1x 6288616
 2x 9339
 2x 370026
 4x 6138173
 3x 241226
 2x 6184784
 2x 306926
 4x 302326
 2x 6016172
 4x 6011815
 1x 6093525
 6x 6102782
 1x 302126
 1x 4162443

2x 4209003
 1x 4209013
 2x 6053077
 2x 4667463
 2x 4515368
 1x 6162892
 2x 301026
 3x 371026
 1x 6087083

1x 6286146
 2x 366626
 1x 379526
 2x 346026
 1x 4106977
 2x 303526
 1x 383226
 3x 6001494
 3x 6147030

2x 6229130	1x 6264069	4x 4524929	2x 6055172	4x 4502089	3x 4245571	4x 6133896	1x 4585751	4x 4225469	6x 6174856
5x 6269971	1x 6223655	14x 6278436	4x 6001824	2x 4264569	11x 4543949	3x 6186823	6x 6264025	4x 4645400	3x 4645103
1x 302328	1x 6247798	2x 4177932	1x 6132790	2x 4507080	2x 6020923	2x 6187591	3x 4539060	9x 6201911	3x 6288632
1x 6023083	1x 6220959	2x 6055069	1x 4524098	2x 4507080	2x 6020923	1x 6194726	1x 6288639	1x 6238874	4x 6008297
2x 4107758	1x 6252258	2x 6067913	4x 6100644	5x 6250216	4x 6262972	1x 6168645	2x 4541528	3x 6248944	5x 4271949
2x 4296081	2x 6238856	2x 6289113	5x 4521914	3x 6253282	9x 4586057	1x 6173138	3x 4650865	6x 6035291	1x 6122977
1x 6182261	2x 6163901	3x 4125278	1x 4496699	19x 6055169	4x 4260493	2x 4539114	4x 6037995	4x 4211180	1x 4216695
5x 4666322	2x 6163901	2x 4118827	3x 4528604	6x 6055171	4x 4260493	8x 4541376	4x 6236437	1x 4221886	7x 6196221
7x 6254484	1x 6286876	2x 4160593	2x 6035540	2x 4521915	15x 6216880	6x 6212007	4x 6236437	1x 4221886	3x 4211210
2x 4579659	1x 6244904	1x 4158355	1x 4626904	4x 4245570	6x 4245566	4x 6252545	6x 6209681	1x 4211219	3x 4211210
8x 4570877	2x 6246888	4x 6210229	1x 4267874	19x 6013102	4x 4521948	2x 6212010	2x 6028736	2x 4211150	1x 4211257
2x 6253417	2x 6251294	1x 6240515	1x 4267874	3x 6288626	1x 6247894	1x 4539090	2x 4622062	1x 4211149	4x 6102975
1x 6223040	1x 6286161	1x 6167767	2x 6015424	4x 4521948	1x 6247894	13x 4539097	2x 6020147	1x 6058084	1x 6248918
1x 6253418	1x 6247364	12x 6177135	16x 4255413	3x 6289117	1x 6247895	1x 4539102	1x 6060731	1x 6058084	1x 6248918
		3x 4249891	3x 4249891	5x 6013975	2x 6258145	1x 6288635	4x 6186673	5x 4595814	2x 6103769
		3x 6135606	3x 6135606		2x 4616578	6x 4539105	3x 4211242	1x 6270078	
							4x 4504376		

2x
4211189

3x
4211225

3x
4211190

1x
4211157

1x
6280388

1x
4579690

2x
4211186

2x
4211193

1x
4211247

1x
4585337

1x
6096716

2x
4211483

2x
4521921

1x
6262085

2x
4558953

1x
4211389

1x
6163478

1x
6227897

1x
4211735

3x
4211475

2x
6043656

1x
4211388

10x
4211398

1x
6015344

2x
4598526

2x
6217876

2x
4282786

1x
4211413

4x
6212077

1x
4208988

1x
4209006

1x
6177078

1x
4211387

1x
4211436

2x
4211349

3x
4211429

3x
4558169

1x
4211386

5x
6015347

7x
4211395

1x
6039346

6x
4211438

1x
4211481

2x
4211838

5x
4251149

1x
4211522

1x
4211401

3x
4662161

6x
6221607

4x
4210660

1x
6171068

1x
6171068

1x
6057389

4x
6209679

2x
4618670

1x
6237878

1x
6288690

1x
6284416

1x
6287783

1x
6114026

1x
6163442

1x
6287796

1x
6287798

1x
6162427

1x
6288448

1x
6288451

1x
6292182

1x
6288449

1x
6288443

1x
6288445

1x
6288446

2x
6060800

1x
4529247

9x
6190252

3x
6186672

4x
6146054

2x
6212377

3x
4569316

1x
6107194

1x
6081658

1x
6093529

1x
6223146

2x
4519970

1x
4529672

4x
6058257

1x
6226792

1x
6055384

20x
6057986

7x
6215606

2x
4569385

1x
6287762

1x
6262262

7x
4569382

2x
6162886

18x
4656783

9x
6218360

2x
6102967

6x
6192922

7x
6167700

1x
6160320

8x
6099341

10x
4633691

3x
6161155

2x
6215447

1x
6076677

3x
4619636

1x
6132264

5x
6214235



Customer Service
Kundenservice
Service Consommateurs
Servicio Al Consumidor
LEGO.com/service or dial
: 00800 5346 5555
: 1-800-422-5346



SHARE YOUR IDEA
PARTAGE TON IDÉE
COMPARTE TU IDEA

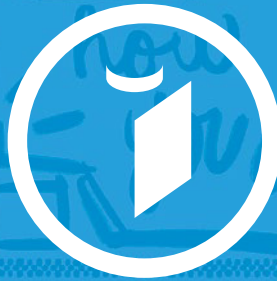

GATHER SUPPORT
OBTIENS DE L'APPUI
OBTÉN APOYOS

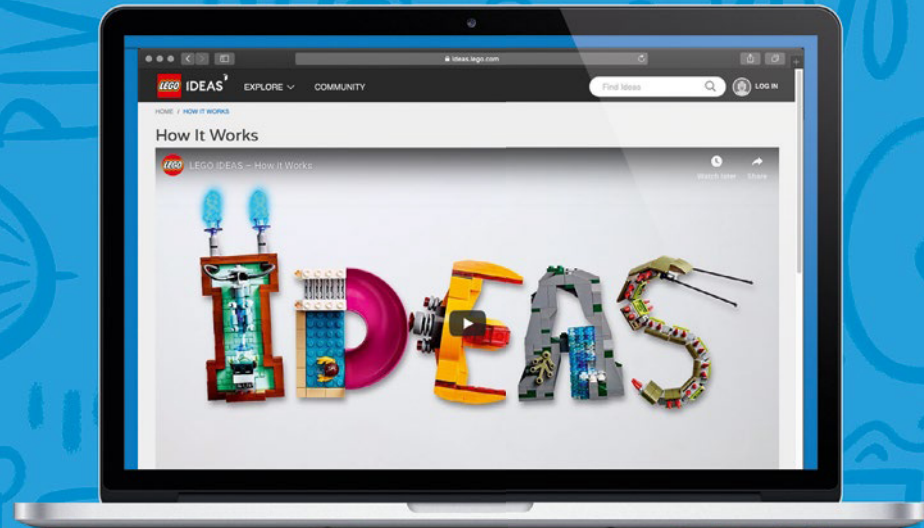

NEW LEGO® PRODUCT
NOUVEAU PRODUIT LEGO®
NUEVO PRODUCTO LEGO®



LEGO® REVIEW
EXAMEN LEGO®
REVISIÓN DE LEGO®



THE FLINTSTONES and all related characters and elements © & ™ Hanna-Barbera. (s19)
©Disney

[LEGO.com/ideas](https://www.lego.com/ideas)



IDEAS

Do you like this LEGO® Ideas set?

The LEGO Group would like your opinion on the new product you have just purchased. Your feedback will help shape the future development of this product series.

Please visit:

[LEGO.com/productfeedback](https://www.lego.com/productfeedback)

By completing our short feedback survey, you will be automatically entered into a drawing to win a LEGO® prize.

Terms & Conditions apply.

Aimez-vous cet ensemble LEGO® Ideas ?

Le Groupe LEGO aimerait connaître votre opinion sur le produit que vous venez d'acheter. Vos commentaires nous aideront à concevoir les futurs produits de cette gamme.

Veuillez visiter :

[LEGO.com/productfeedback](https://www.lego.com/productfeedback)

En remplissant ce court sondage sur le produit, vous serez automatiquement inscrit à un tirage au sort pour gagner un prix LEGO®.

Des conditions s'appliquent.



¿Te gusta este set LEGO® Ideas?

The LEGO Group quiere conocer tu opinión acerca del nuevo producto que acabas de comprar. Tus comentarios nos ayudarán a dar forma a los futuros productos de esta serie.

Visita:

[LEGO.com/productfeedback](https://www.lego.com/productfeedback)

Al contestar este breve cuestionario de opinión, participarás automáticamente en el sorteo de un producto LEGO®.

Sujeto a términos y condiciones.

LEGO and the LEGO logo are trademarks of the/son des marques de commerce du/son marcas registradas de LEGO Group. ©2019 The LEGO Group.



FRIENDS and all related characters and elements © & ™ Warner Bros. Entertainment Inc. (s19)

6315249