

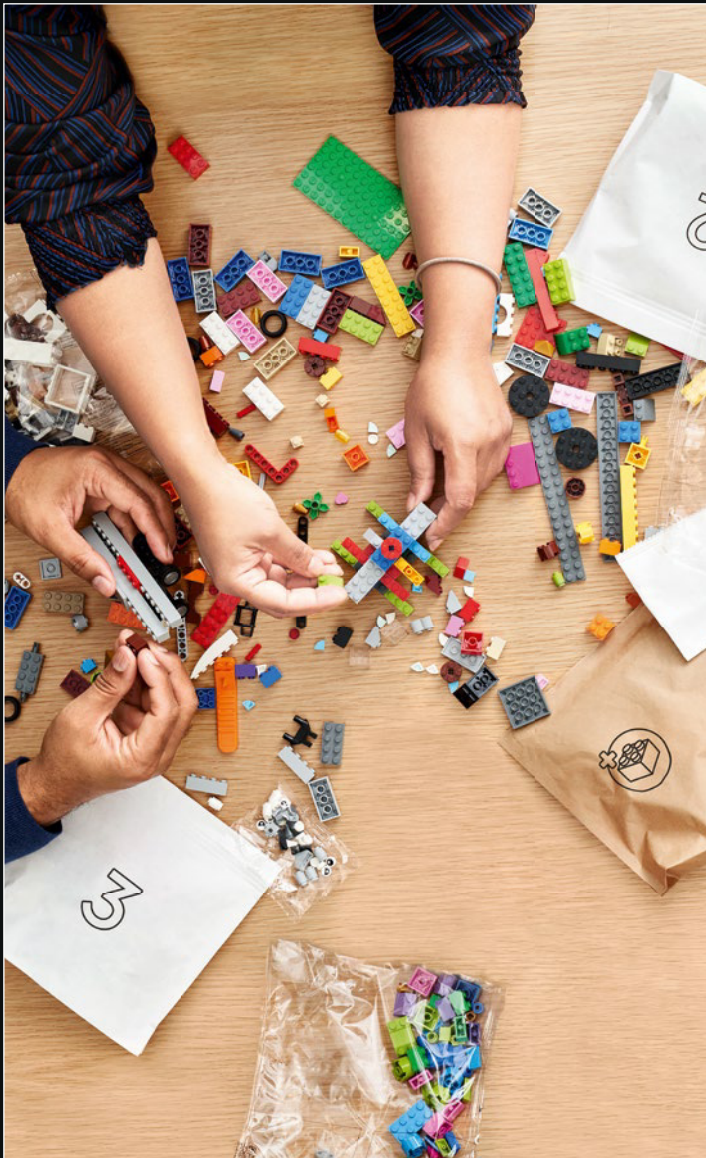

Booklet available in English on
Livret disponible en français sur
Folleto disponible en español en



WE'RE MAKING OUR PACKAGING MORE SUSTAINABLE

We're transitioning from single-use plastic to paper-based packaging. As we progress, you may find a mix of paper and plastic in our boxes.

NOUS RENDONS NOS EMBALLAGES PLUS DURABLES

Nous passons des emballages en plastique à usage unique aux emballages à base de papier. Durant la transition, vous pourriez trouver un mélange de papier et de plastique dans nos boîtes.

QUEREMOS HACER MÁS SUSTENTABLES NUESTROS MATERIALES DE EMBALAJE

Estamos cambiando las bolsas de plástico desechables por bolsas con base de papel. Conforme avanzamos en este propósito, puedes encontrar una mezcla de papel y de plástico en nuestras cajas.

LEGO.com/sustainable-packaging

LEGO® VIP

- 1.** SIGN UP
INSCRIVEZ-VOUS
REGÍSTRATE



- 2.** EARN POINTS FOR
PURCHASES

GAGNEZ DES POINTS
POUR VOS ACHATS
GANA PUNTOS POR
TUS COMPRAS

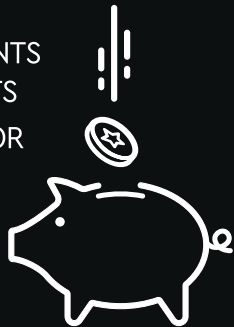

- 3.** REDEEM POINTS FOR REWARDS,
EXPERIENCES, DISCOUNTS & MORE
ÉCHANGEZ DES POINTS CONTRE DES
RÉCOMPENSES, DES EXPÉRIENCES,
DES RÉDUCTIONS ET PLUS ENCORE
CANJEA PUNTOS POR RECOMPENSAS,
EXPERIENCIAS, DESCUENTOS Y
MUCHO MÁS

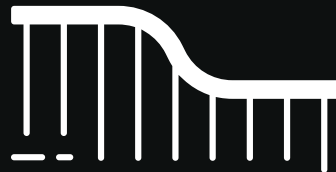
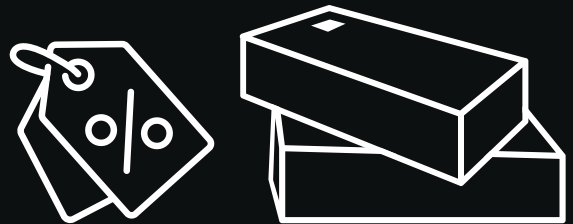

LEGOLAND®



WELCOME TO LEGO® ART

● Add a stroke of warm, vivid and unique modern LEGO® Art to your walls. Recreate a gallery vibe in any room with one of four exclusive designs featured in this booklet or reconstruct your artwork anytime you feel inspired to try new expressions!

BIENVENUE À LEGO® ART

● Ajoutez un trait d'art LEGO® moderne chaleureux, vif et unique à vos murs. Recréez l'ambiance d'une galerie dans n'importe quelle pièce avec l'un des quatre motifs exclusifs présentés dans ce livret ou reconstruisez votre œuvre d'art chaque fois que vous sentez l'inspiration d'essayer de nouvelles expressions !

TE DAMOS LA BIENVENIDA A LEGO® ART

● Dale a tus paredes una cálida, vibrante y original pincelada de estilo moderno con LEGO® Art. Recrea el ambiente de una galería en cualquier habitación con uno de los cuatro exclusivos diseños que encontrarás en este folleto, ¡o reconstruye tus obras de arte en cualquier momento si te llega la inspiración y prueba nuevas expresiones!

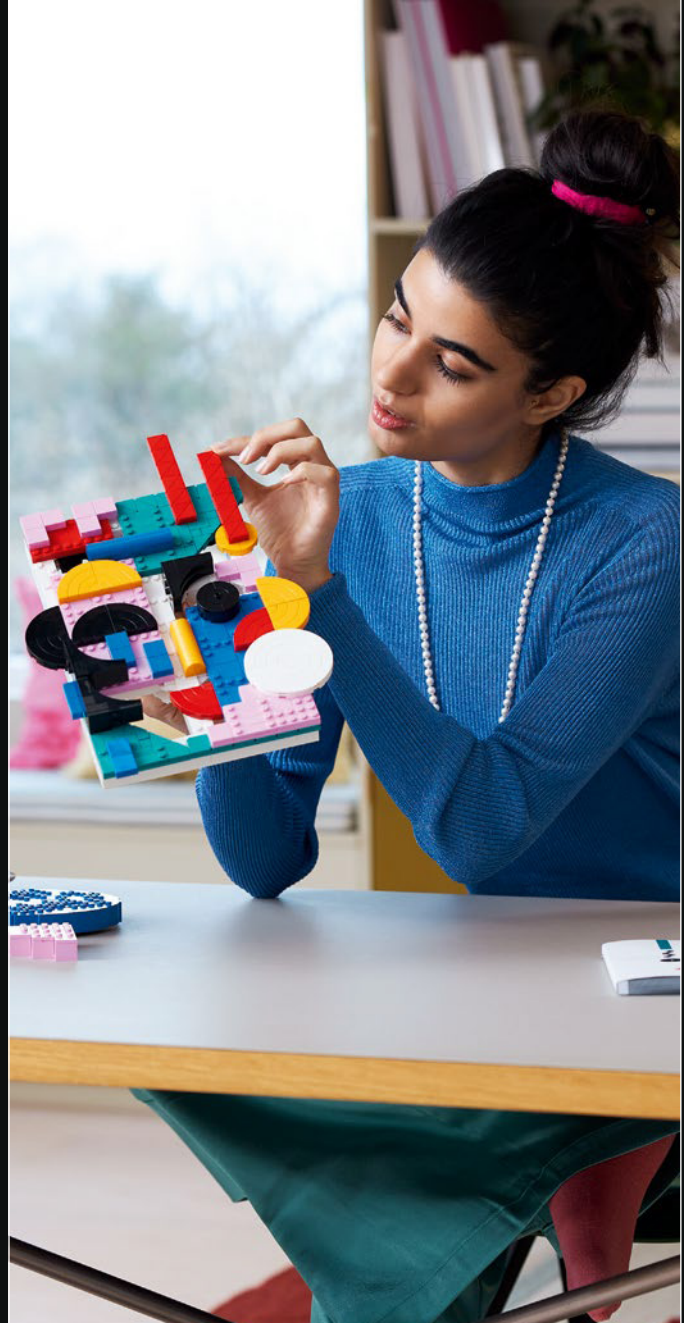



CREATE AND DISPLAY – YOUR WAY

● Klint, Kandinsky, Matisse, YOU. Be inspired by your favorite abstract artists, build your own vibrant masterpiece and turn it into endless new combinations. Find tips to rebuild and combine your modules, and play with colors, lines and shapes to create balance, rhythm, movement – and fun!

CRÉEZ ET EXPOSEZ – À VOTRE FAÇON

● Klint, Kandinsky, Matisse, VOUS. Laissez-vous inspirer par vos artistes abstraits préférés, construisez votre propre chef-d'œuvre éclatant et transformez-le en une infinité de nouvelles combinaisons. Trouvez des astuces pour reconstruire et combiner vos modules, et jouez avec les couleurs, les lignes et les formes pour créer équilibre, rythme, mouvement... et plaisir !

CREA Y EXHIBE A TU MANERA

● Klint, Kandinsky, Matisse, TÚ. Déjate inspirar por tus artistas abstractos favoritos, construye tu propia y llamativa obra maestra, y transfórmala en infinitas combinaciones inesperadas. Consulta nuestros consejos para reconstruir y combinar los módulos, y juega con los colores, las líneas y las formas para crear equilibrio, ritmo, movimiento... ¡y diversión!





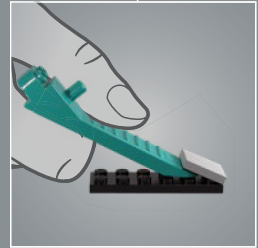
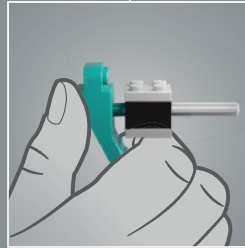
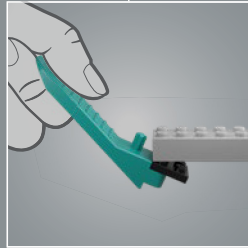
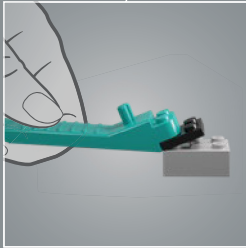
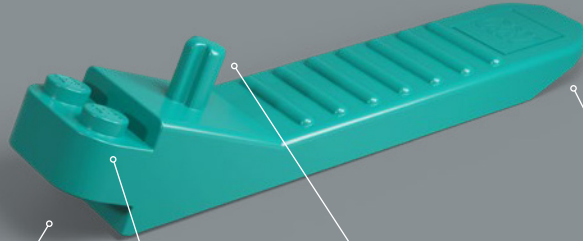

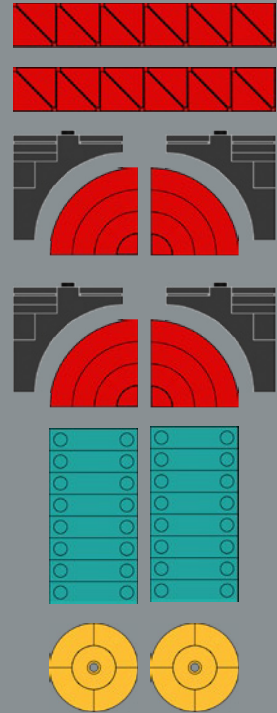
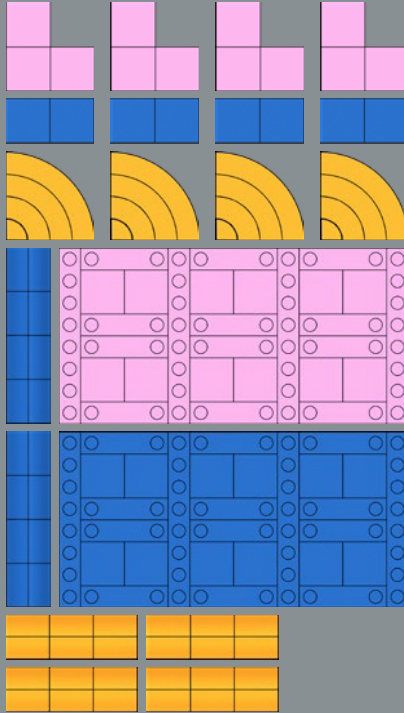
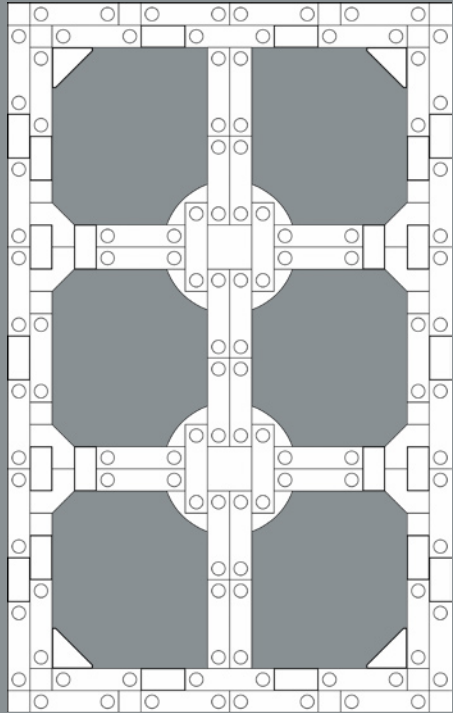
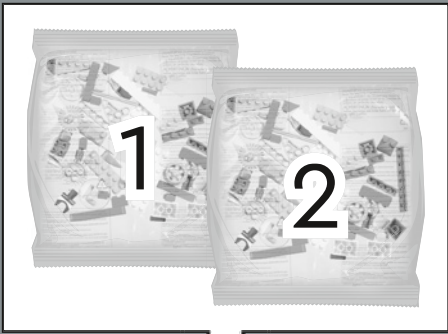

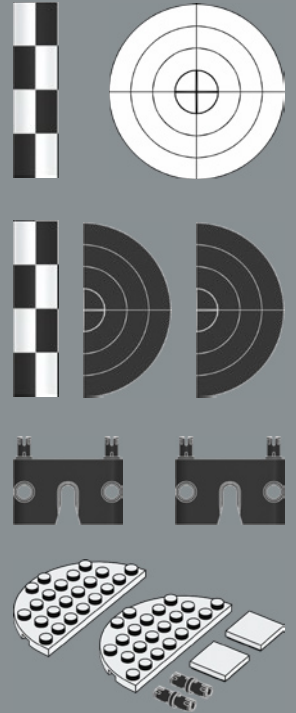
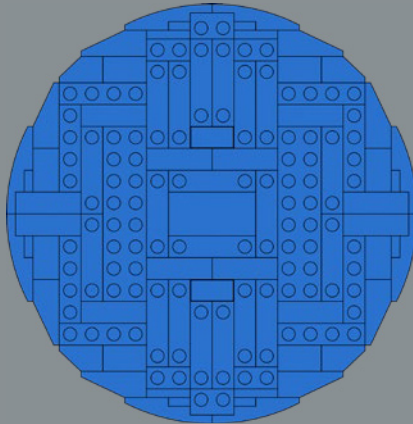
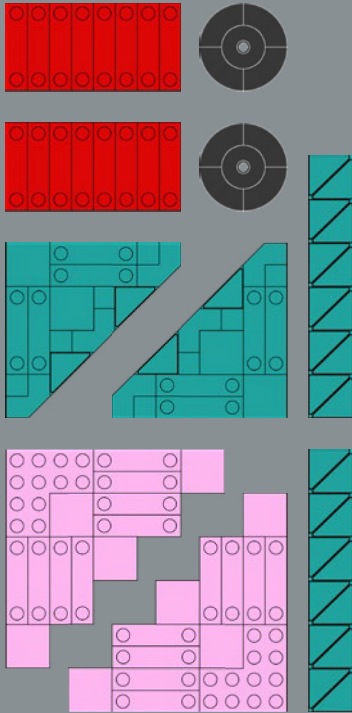

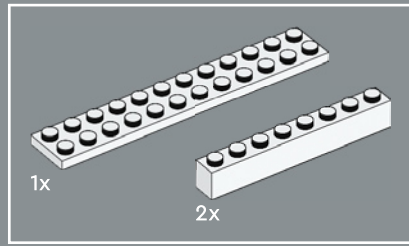

1

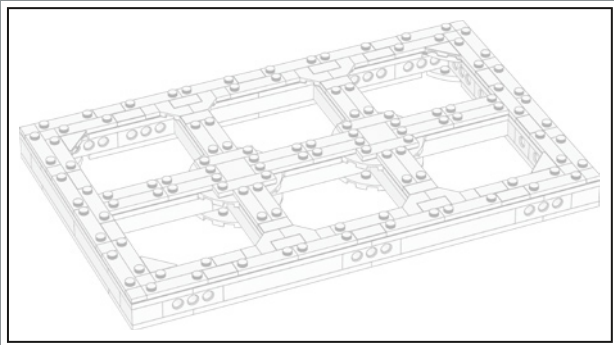
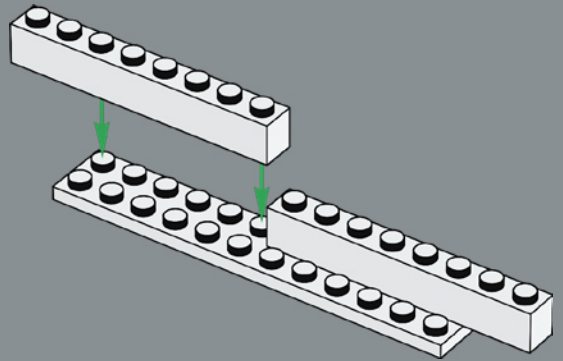

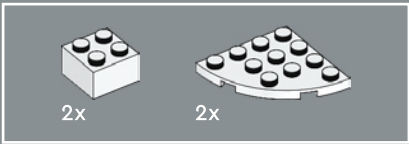

2

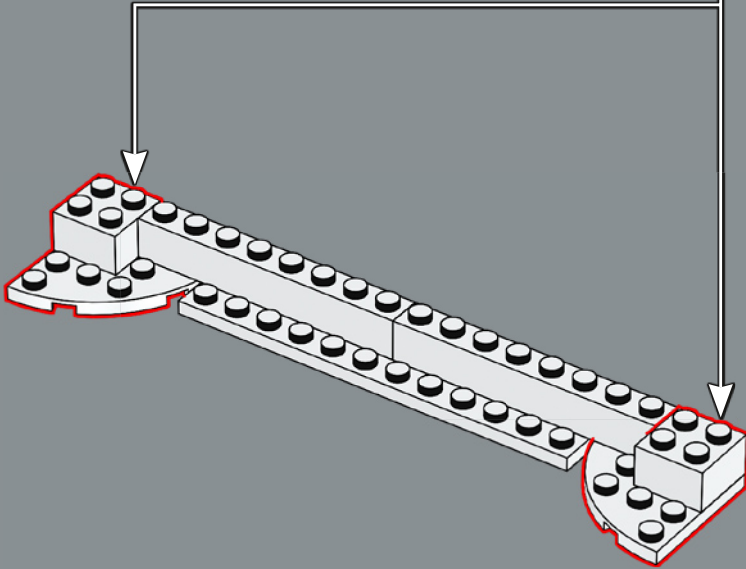
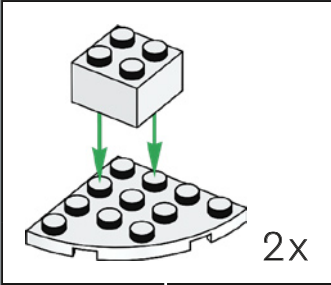

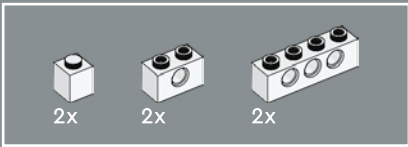

3

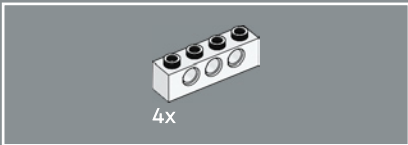
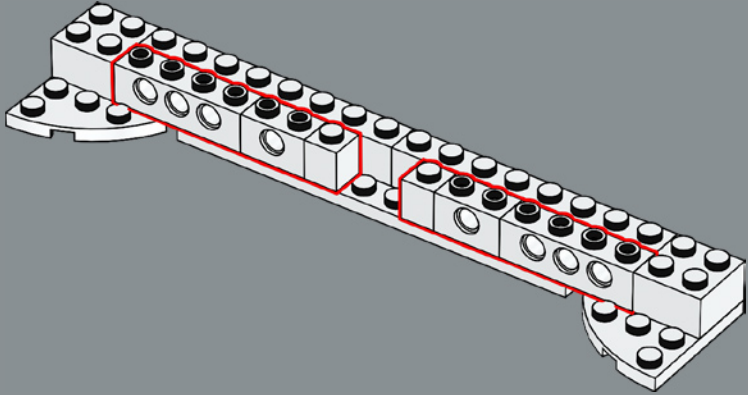

4

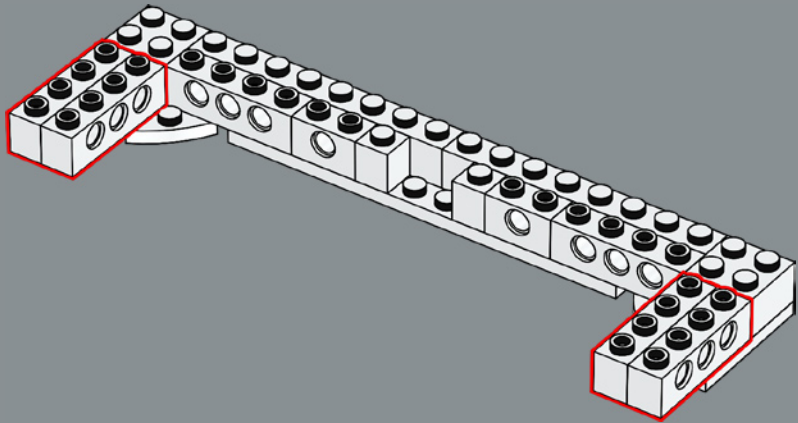

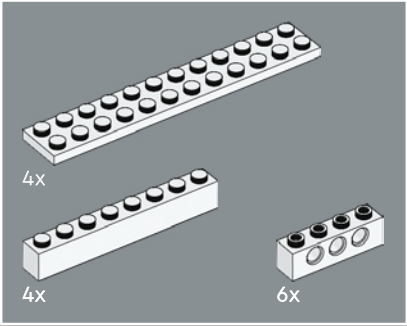
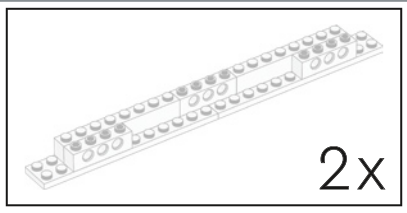

5

1

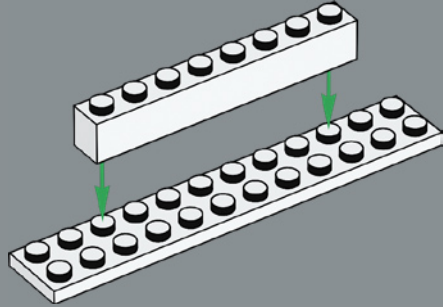

2

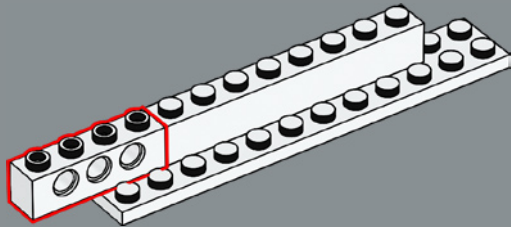

3

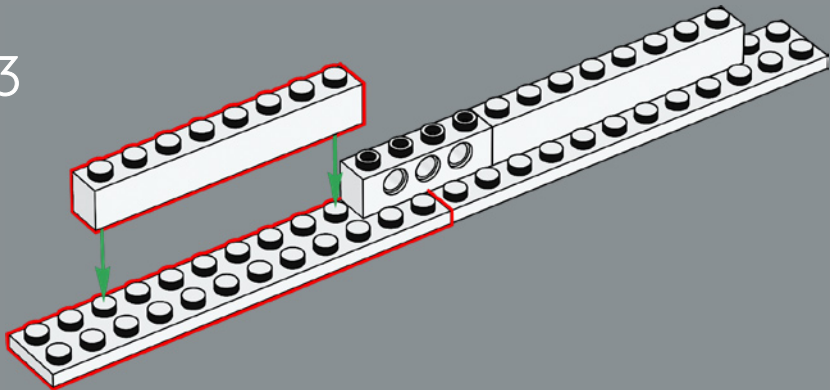

4

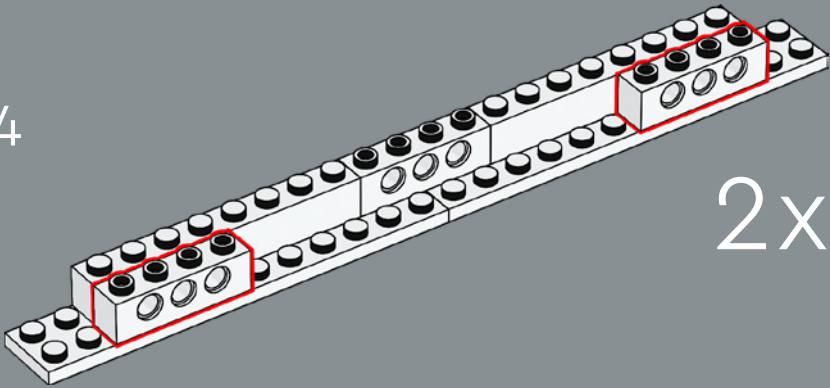

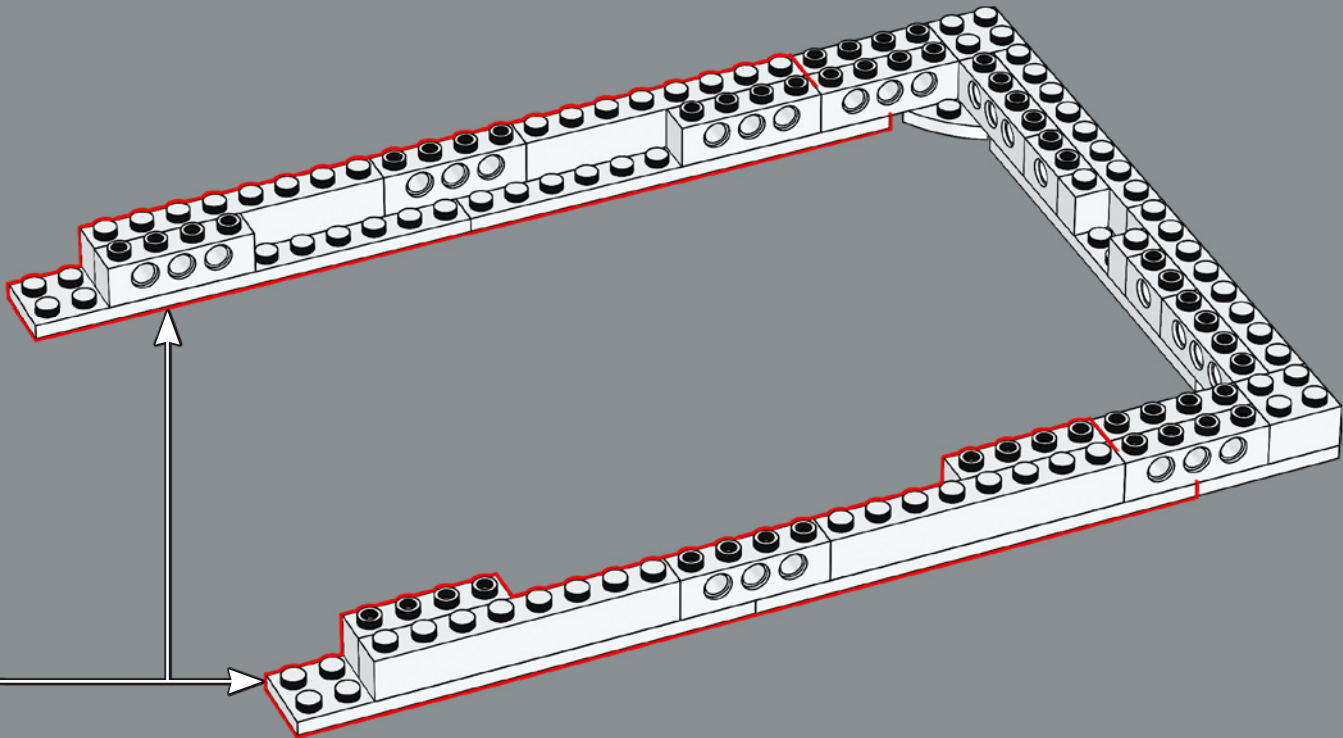

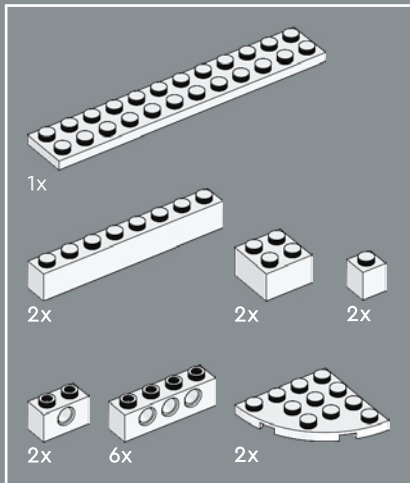
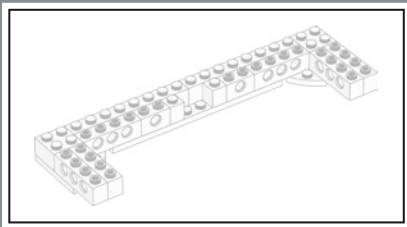

6

1

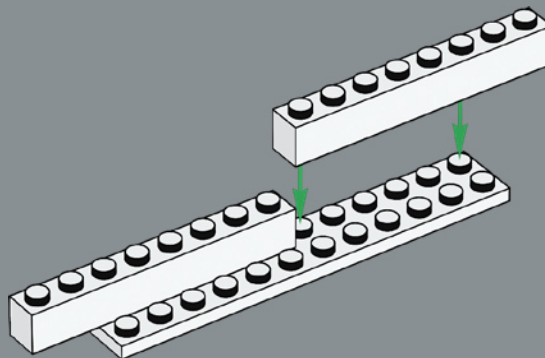

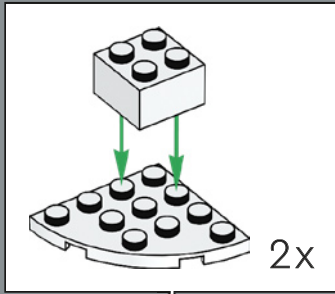

2

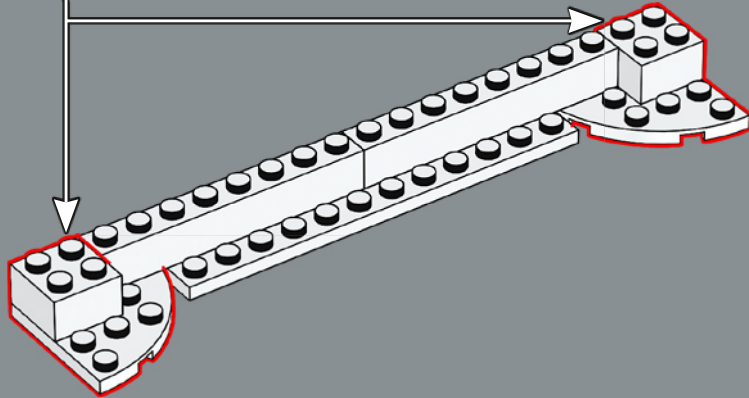

3

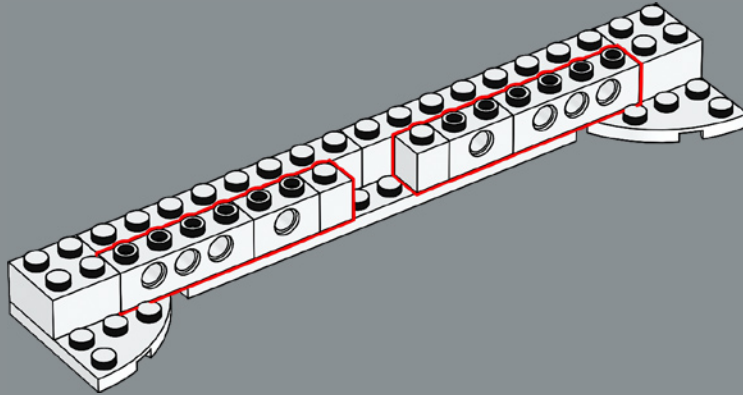

4

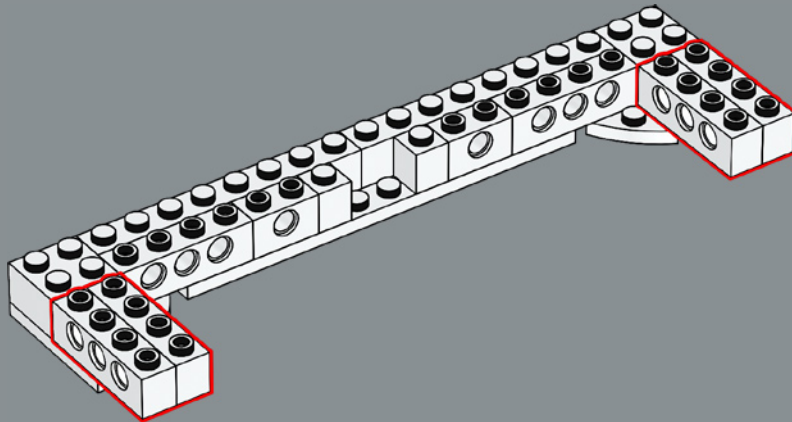

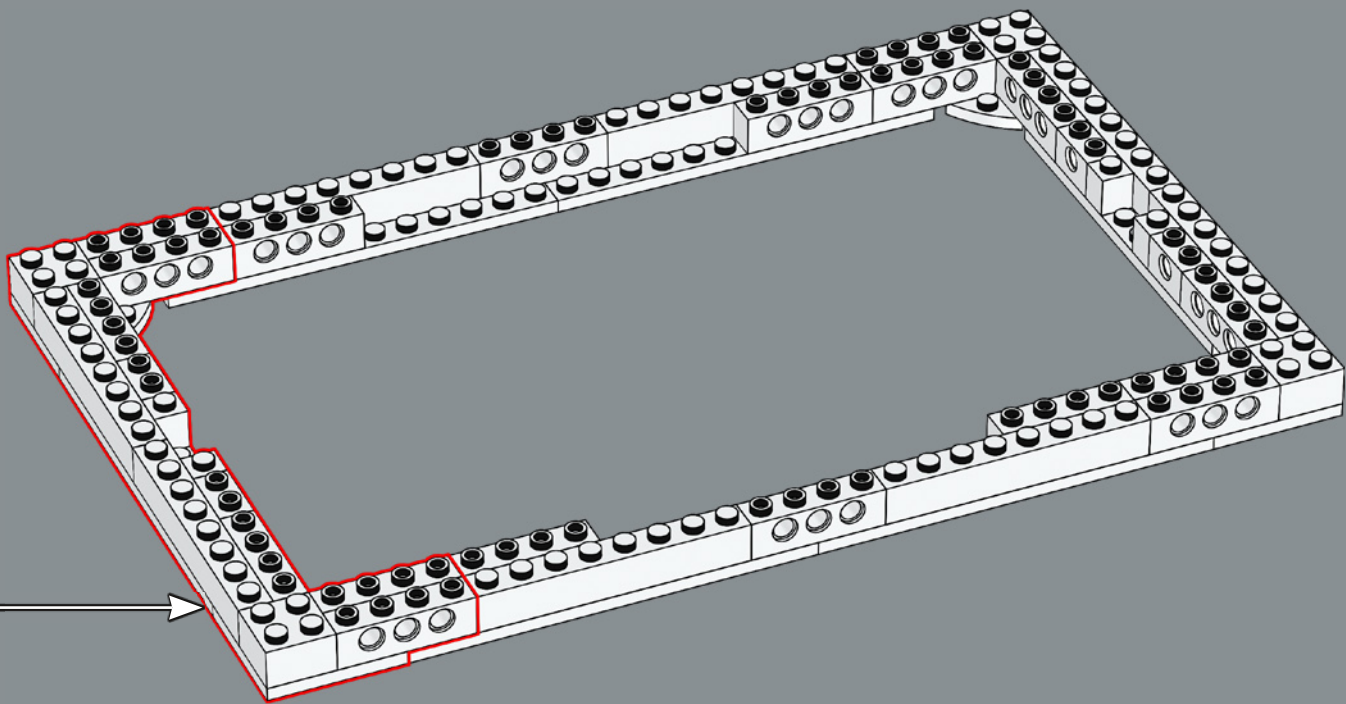

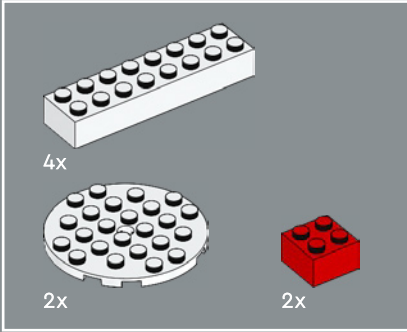
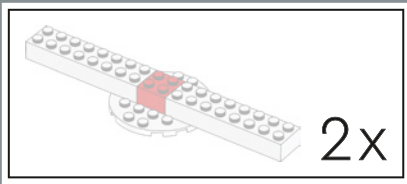

7

1

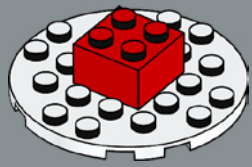

2

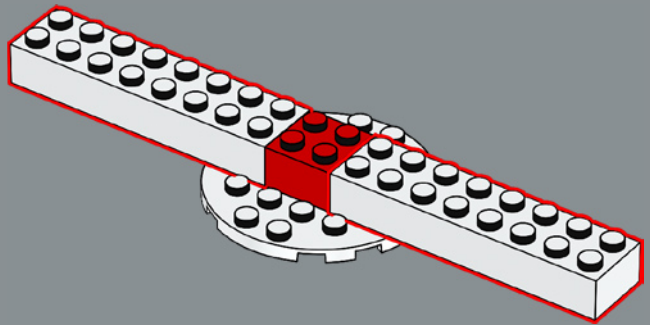

2x

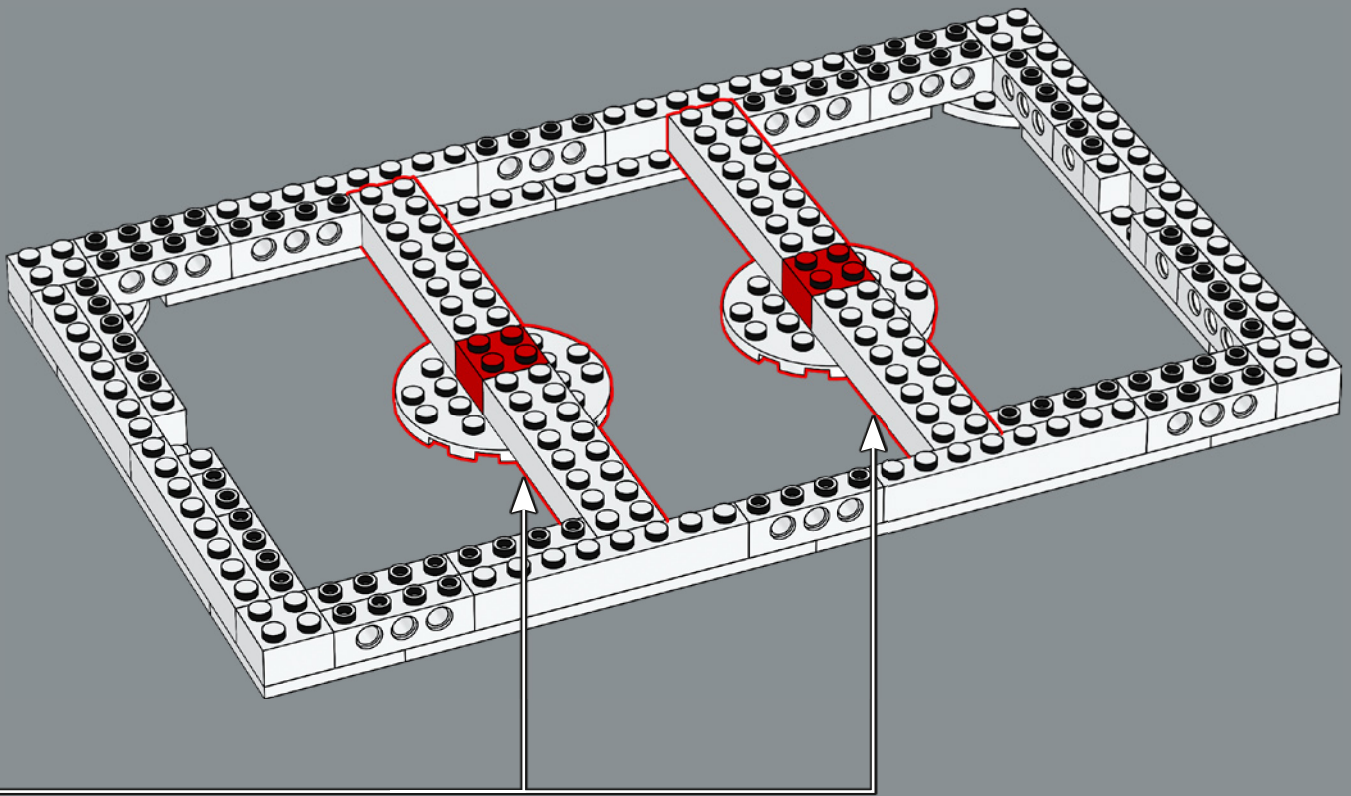

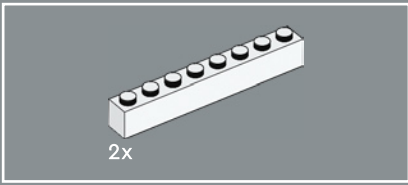

8

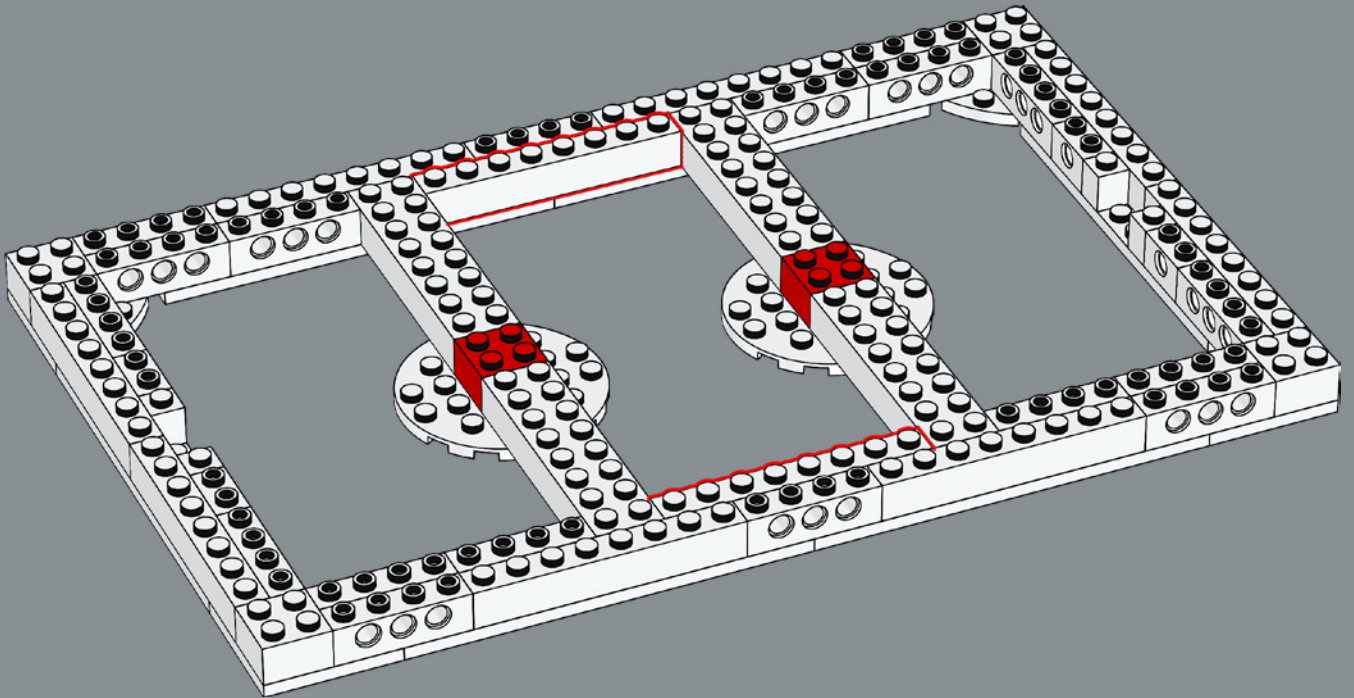

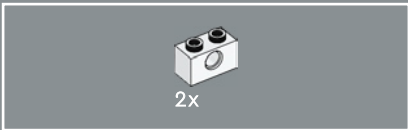

9

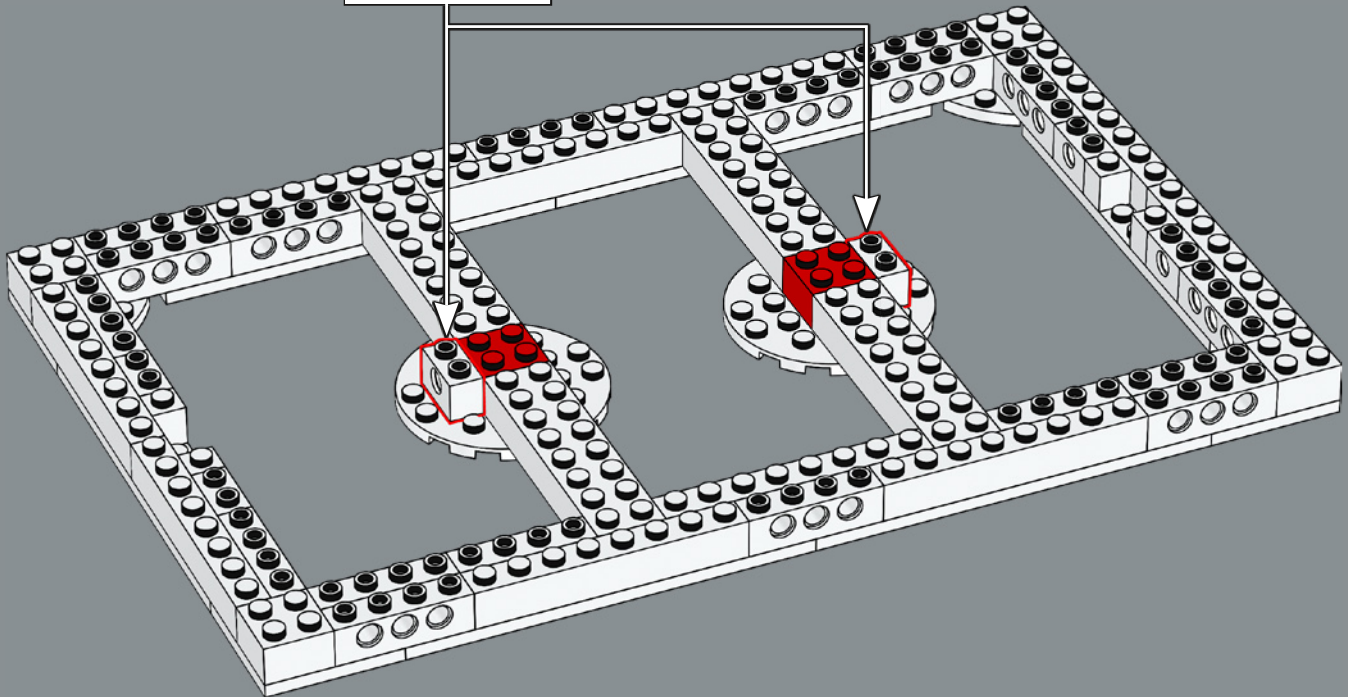
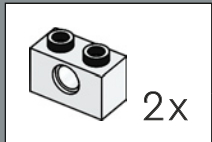

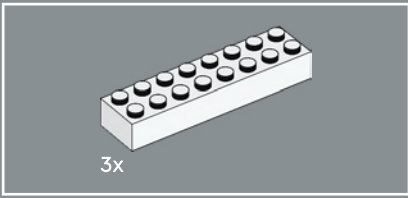

10

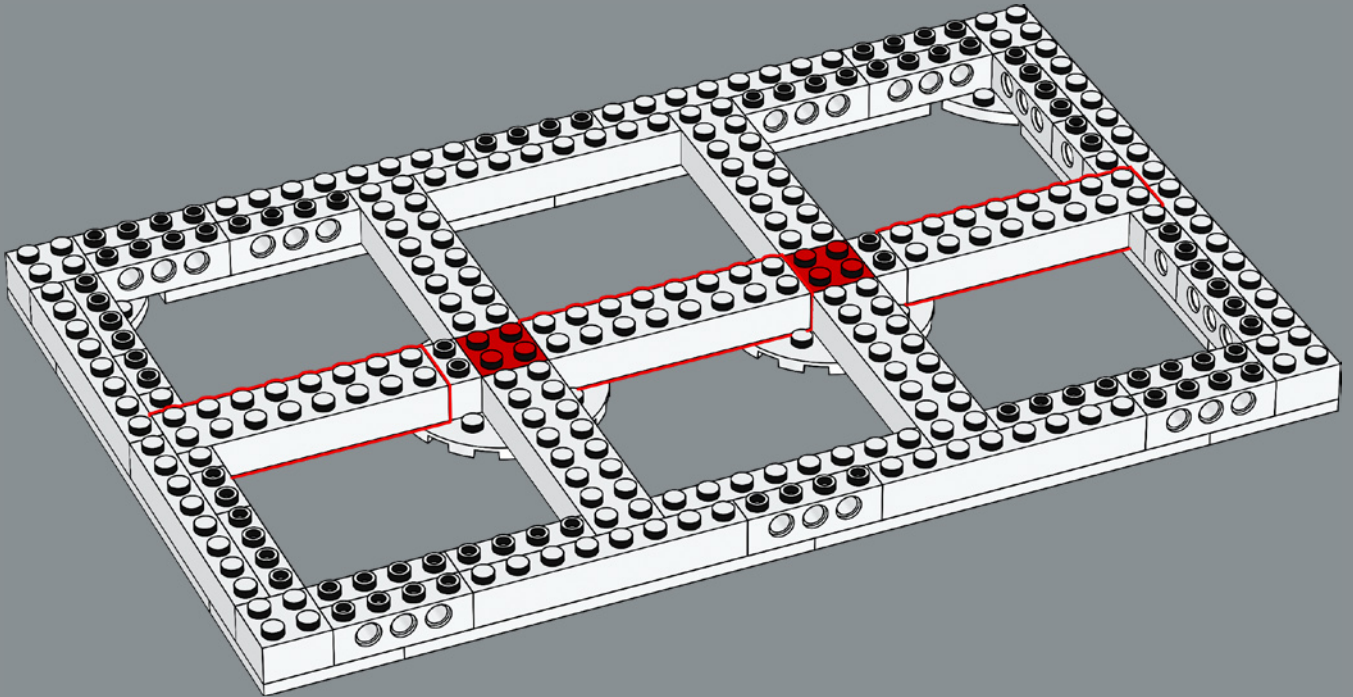



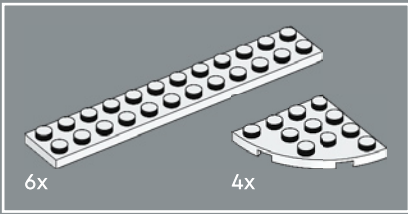

11

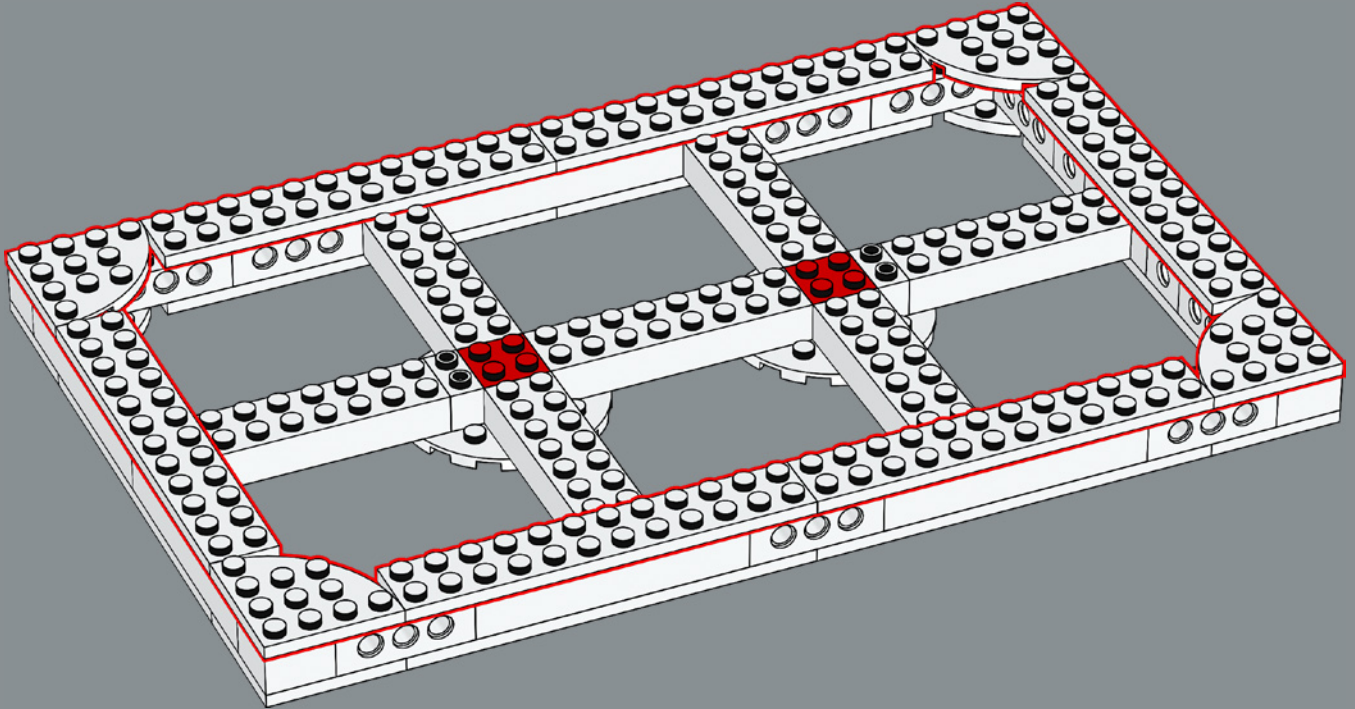

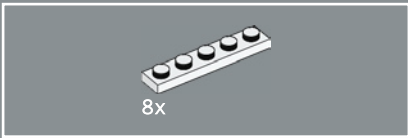

12

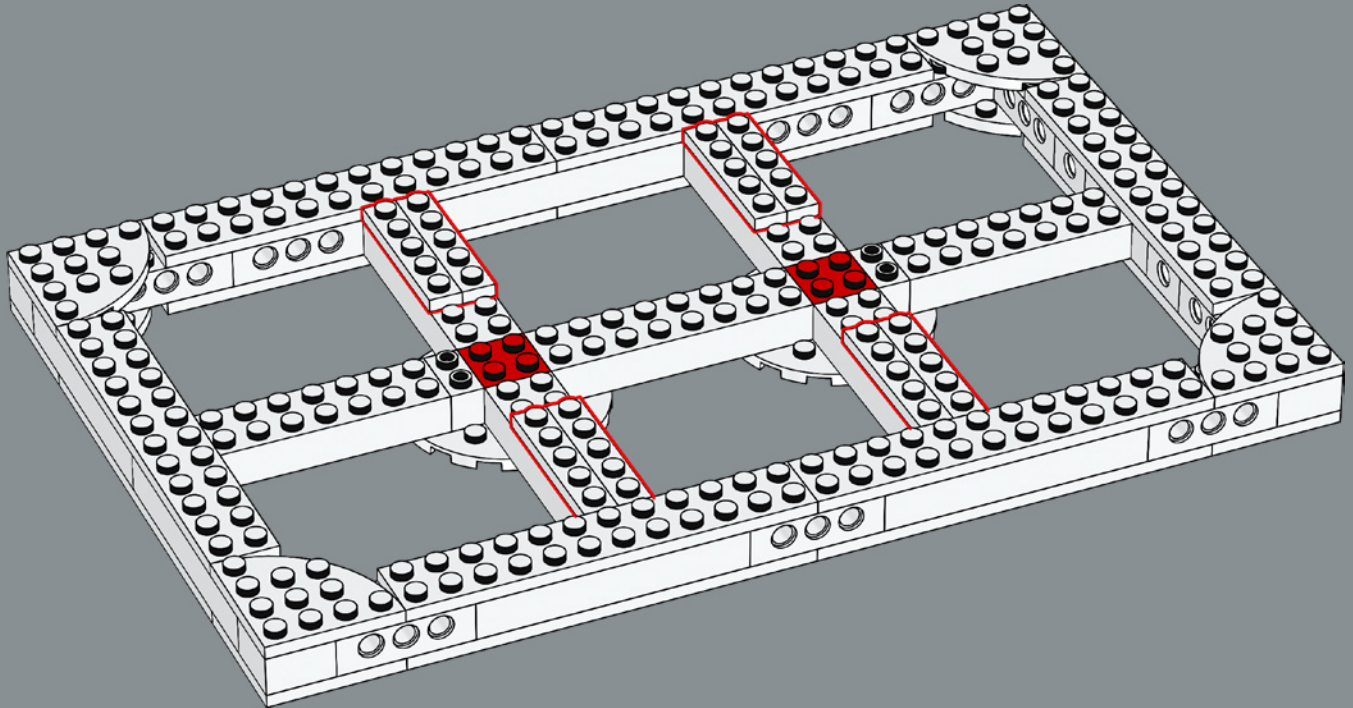

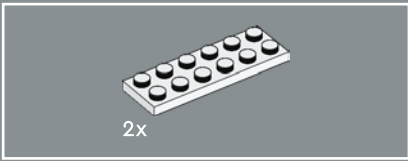

13

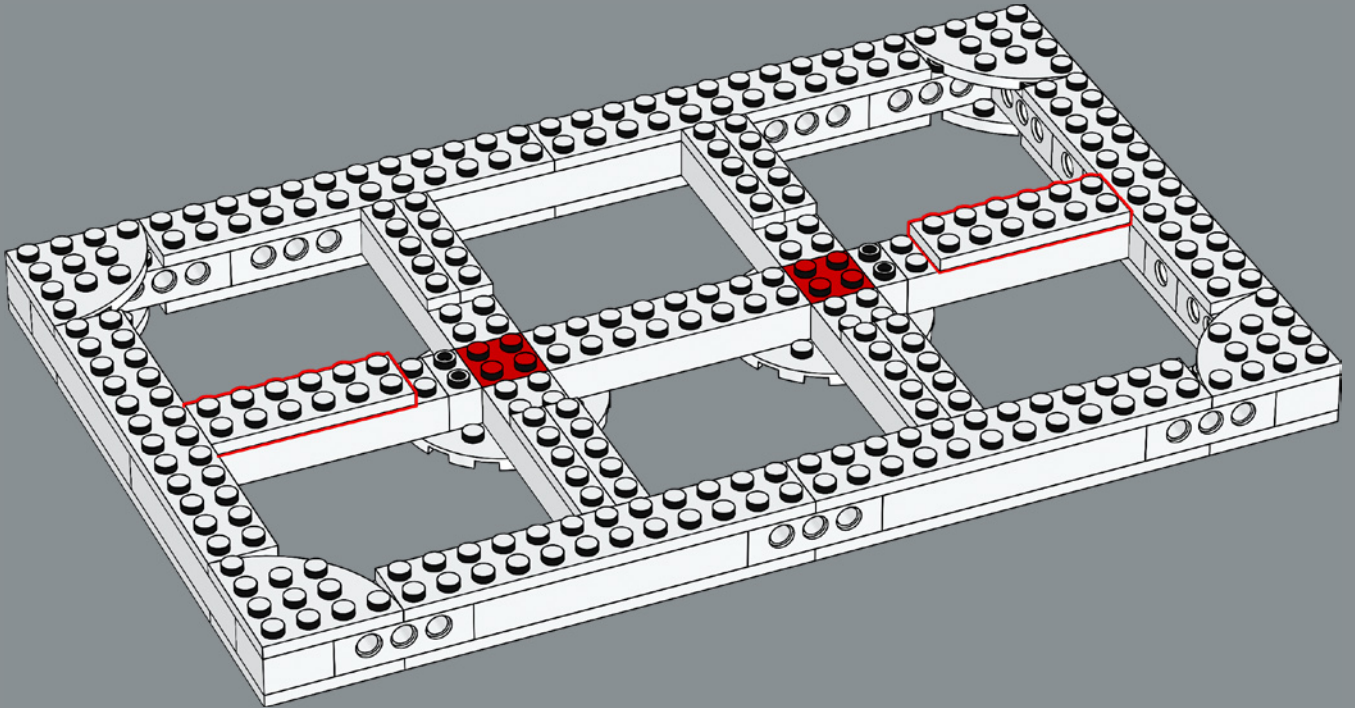

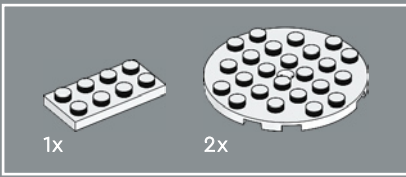

14

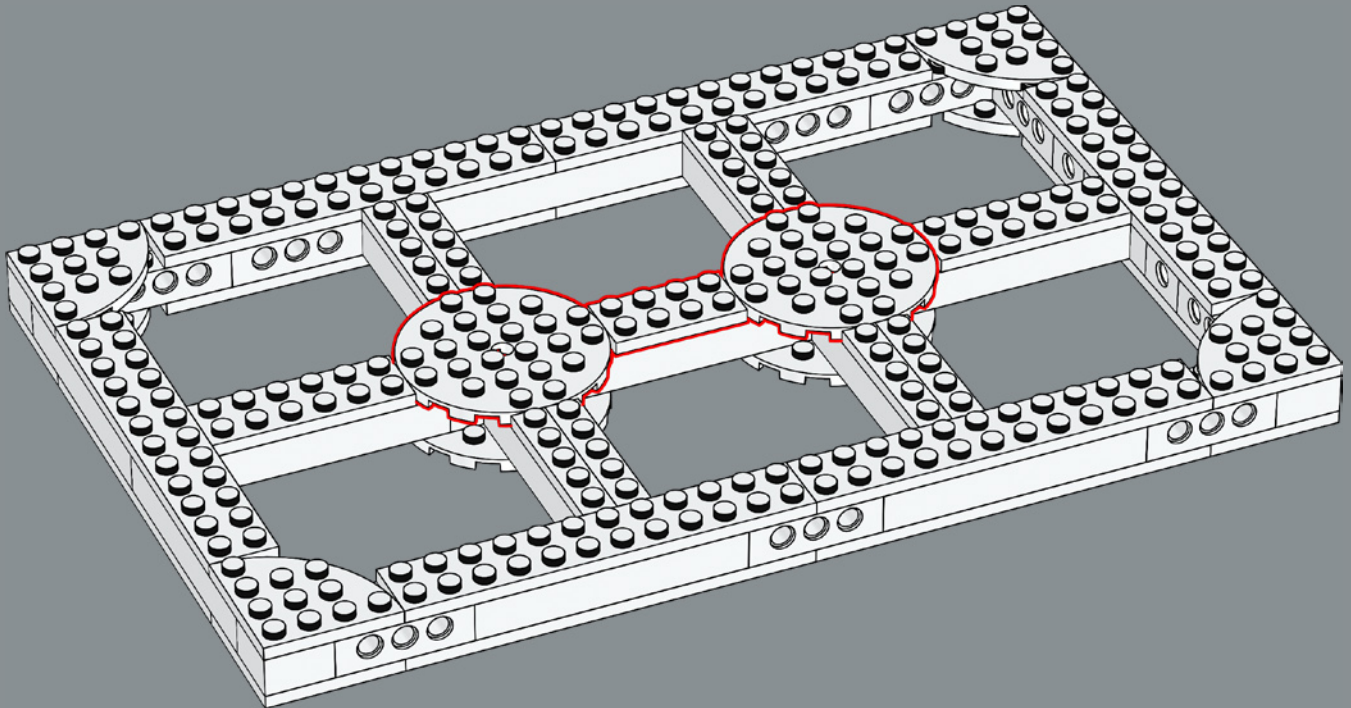



15

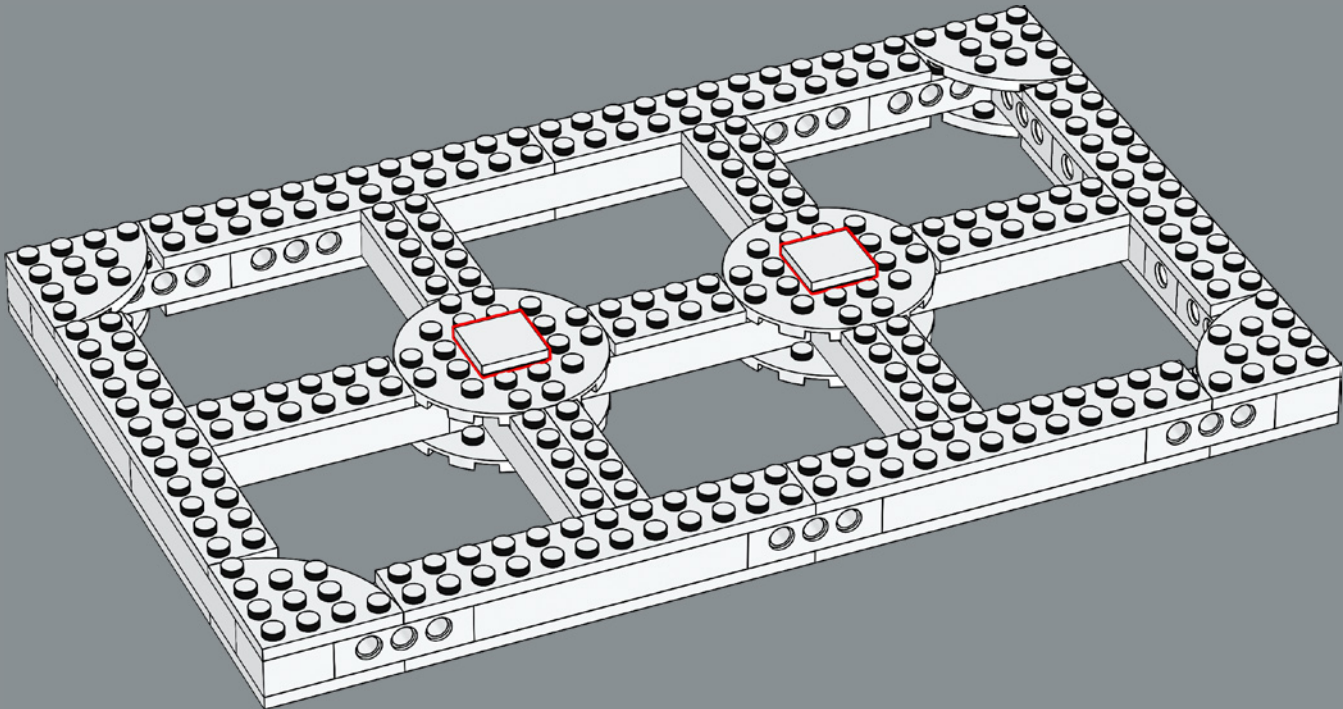

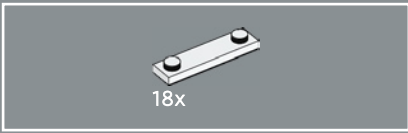

16

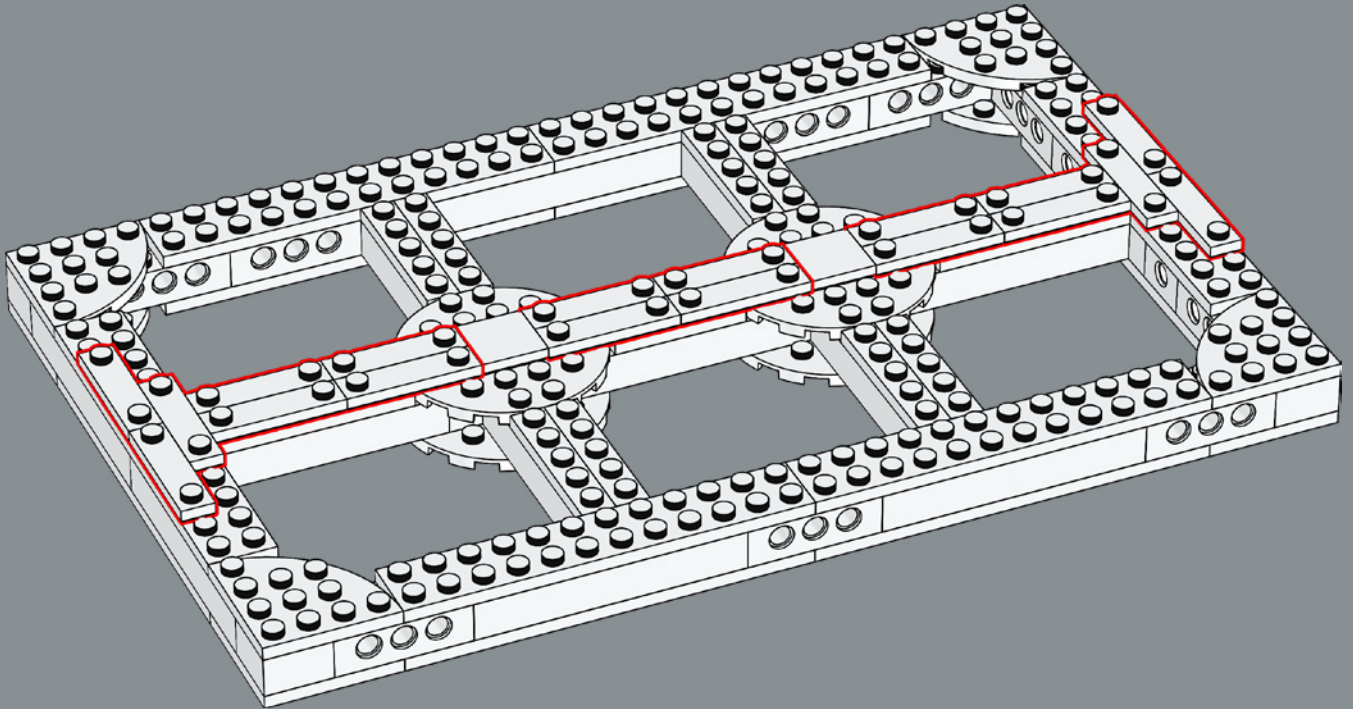

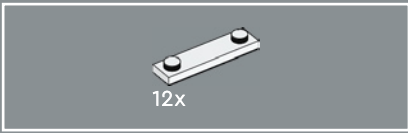

17

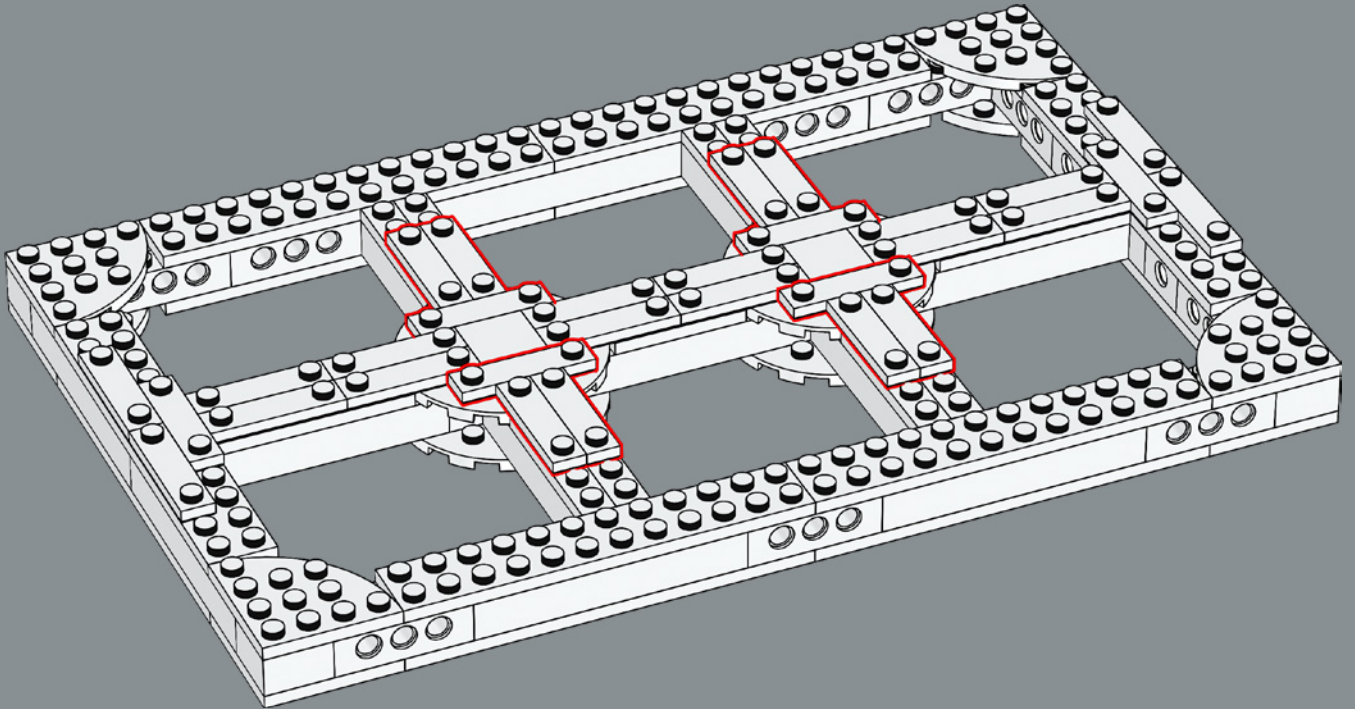

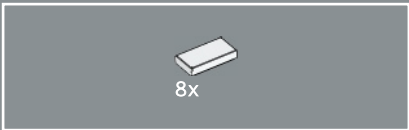

18

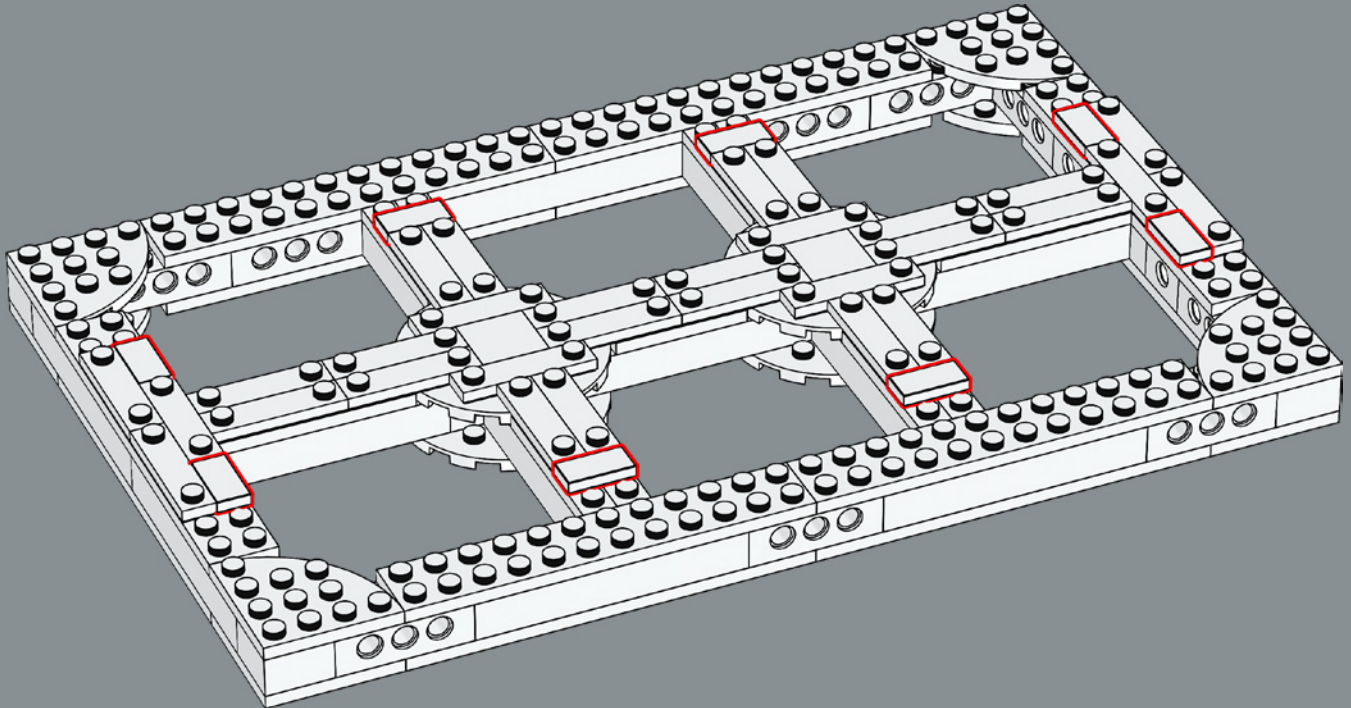

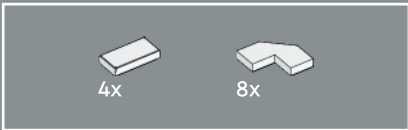

19

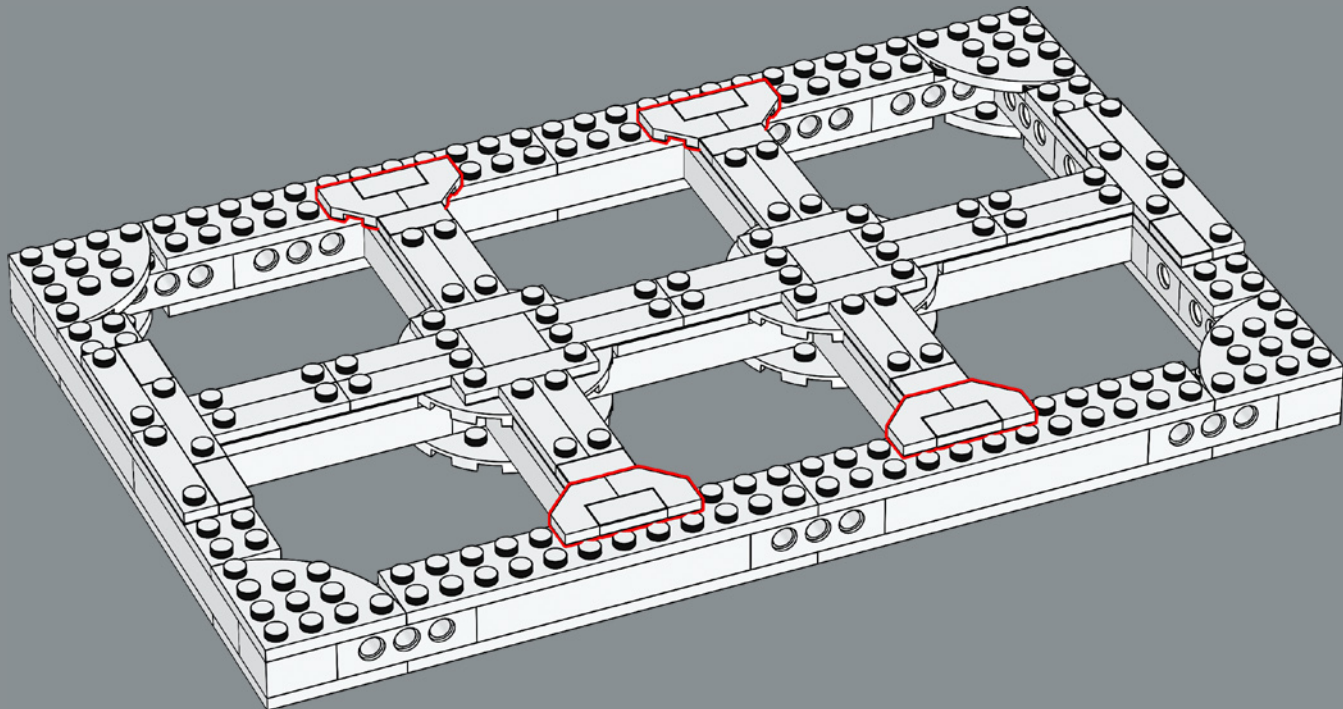



12x

20

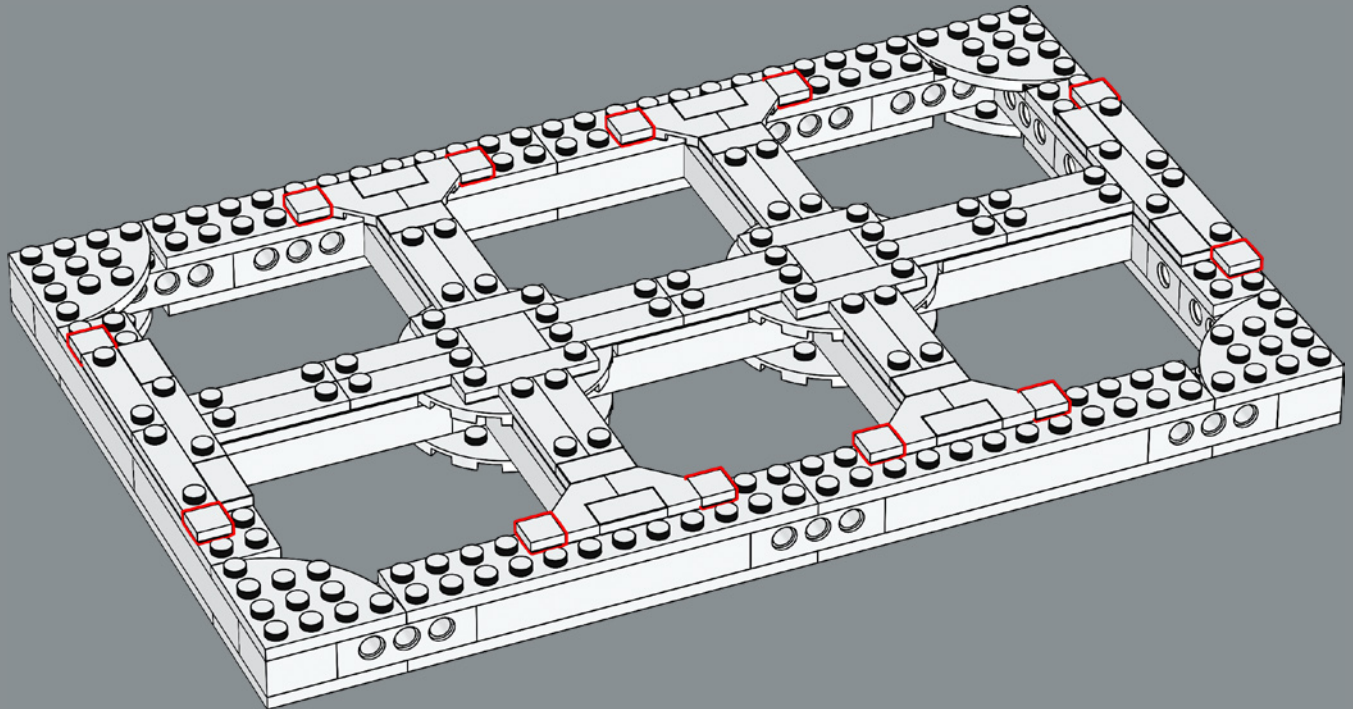

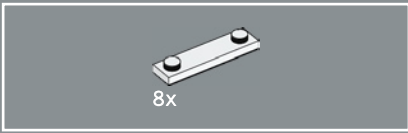

21

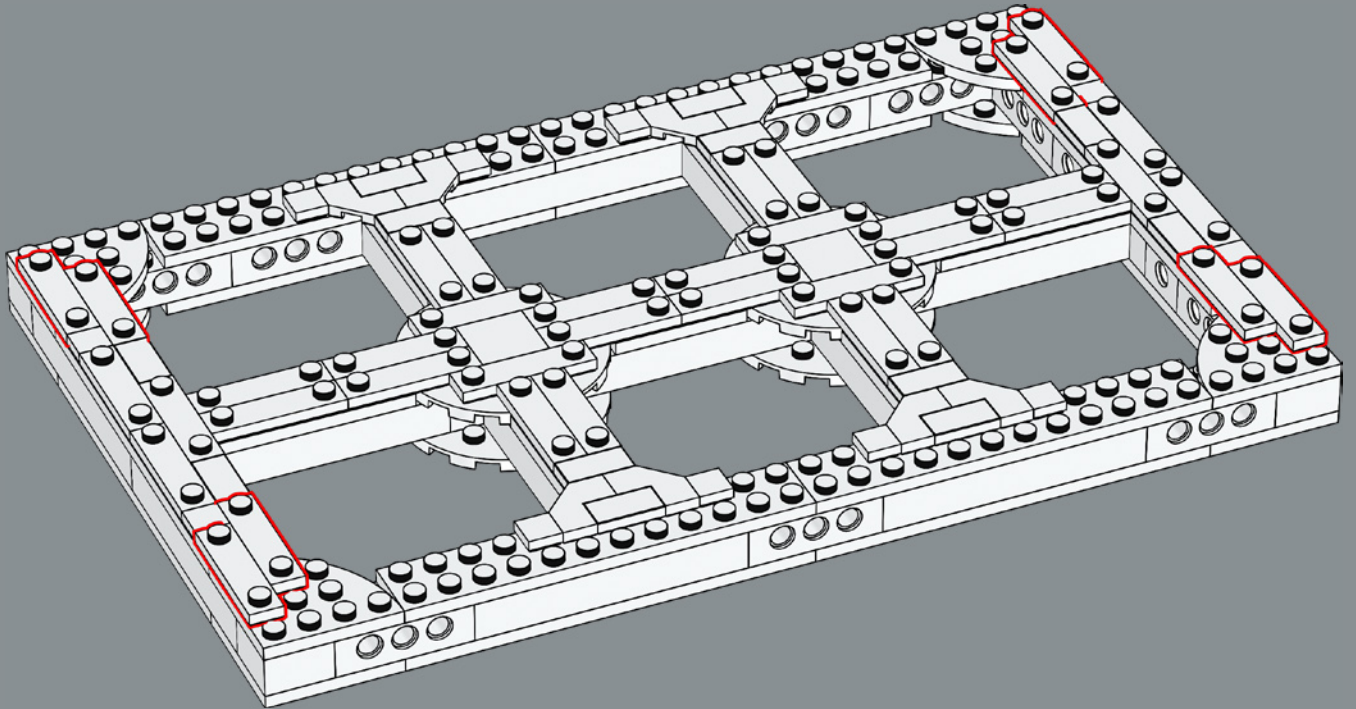



22

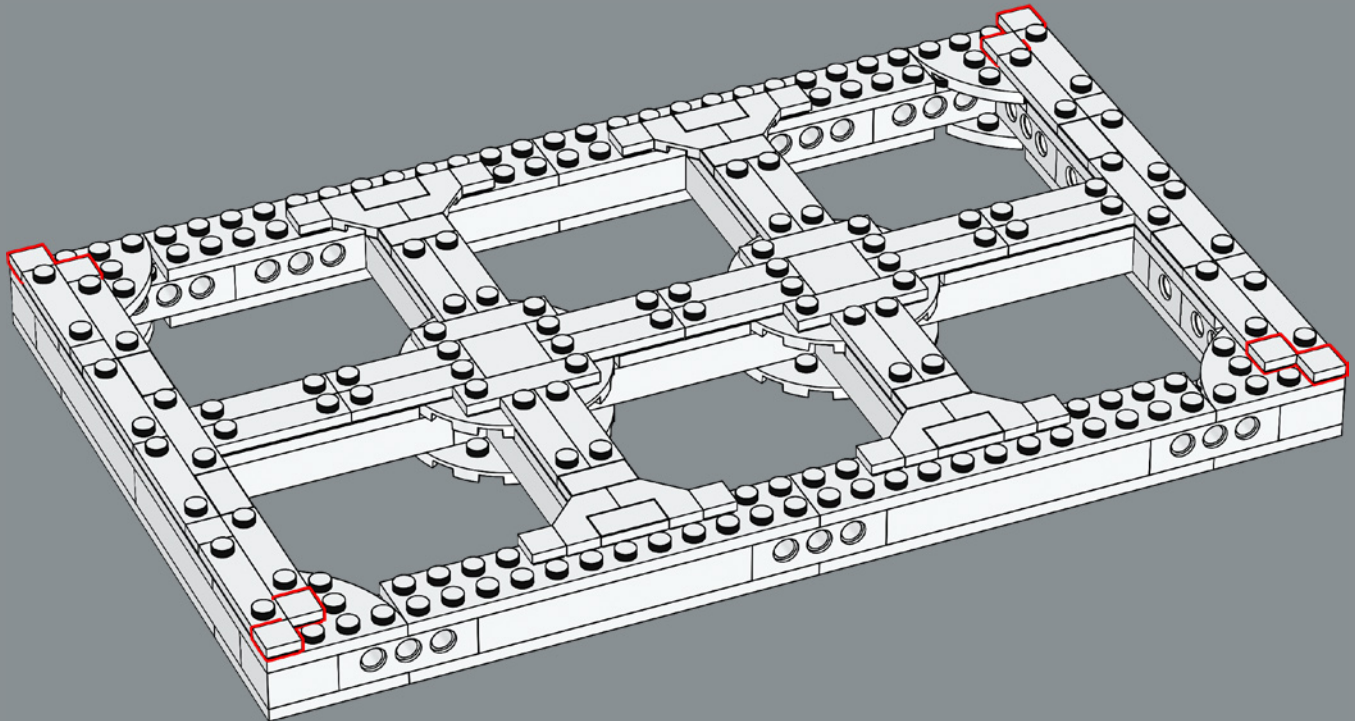

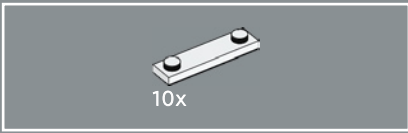

23

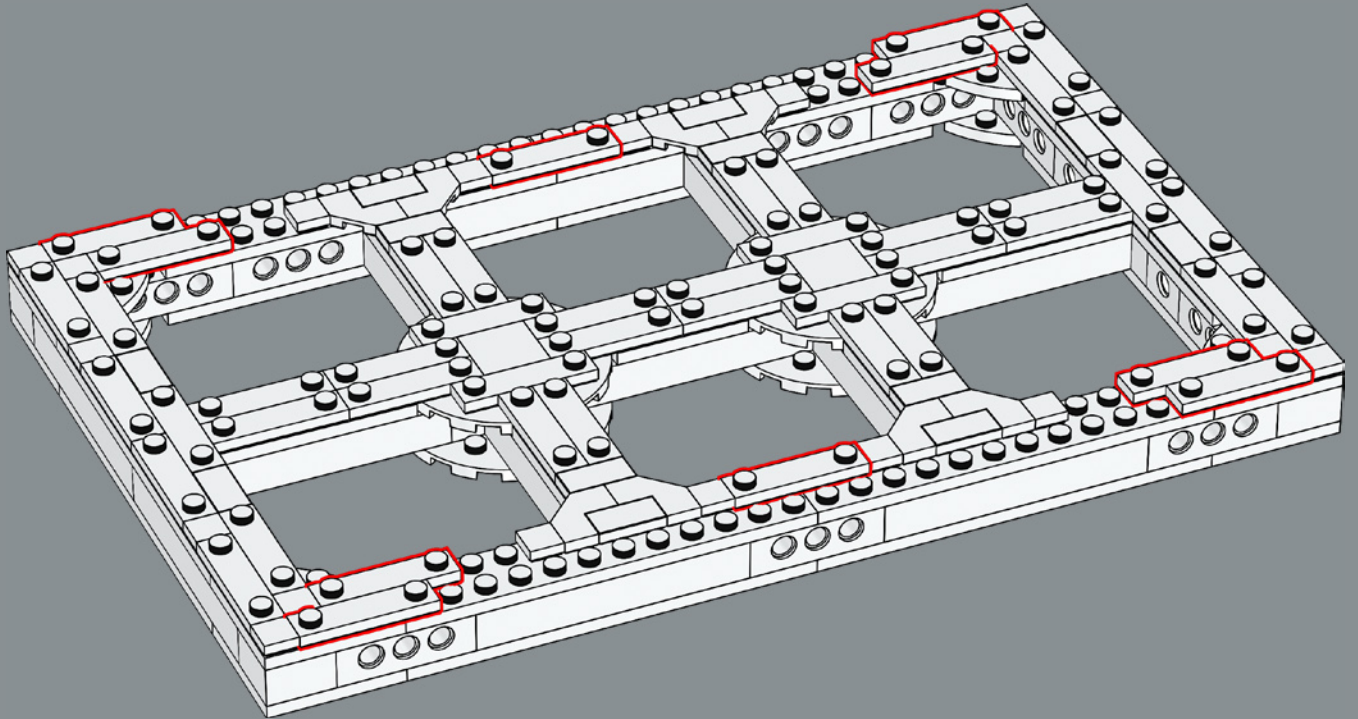



24

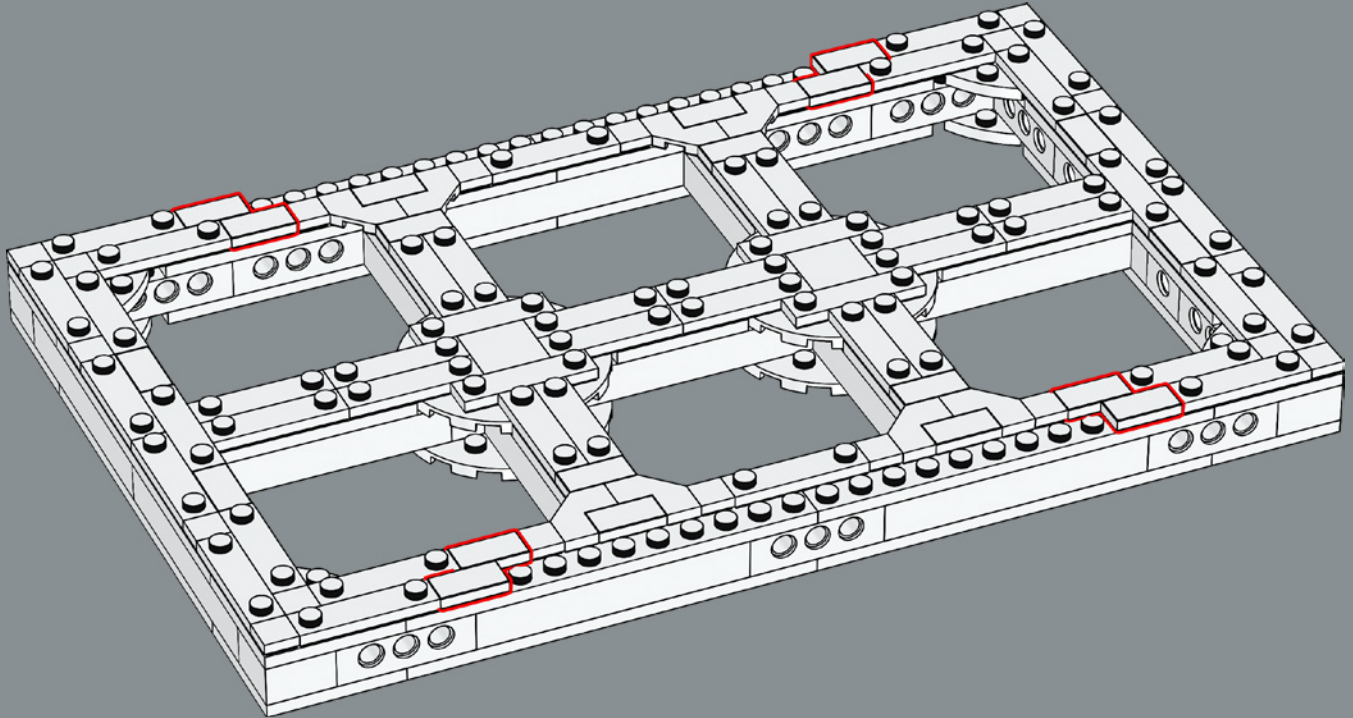

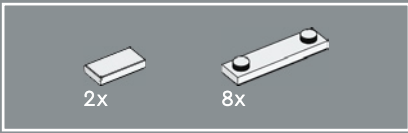

25

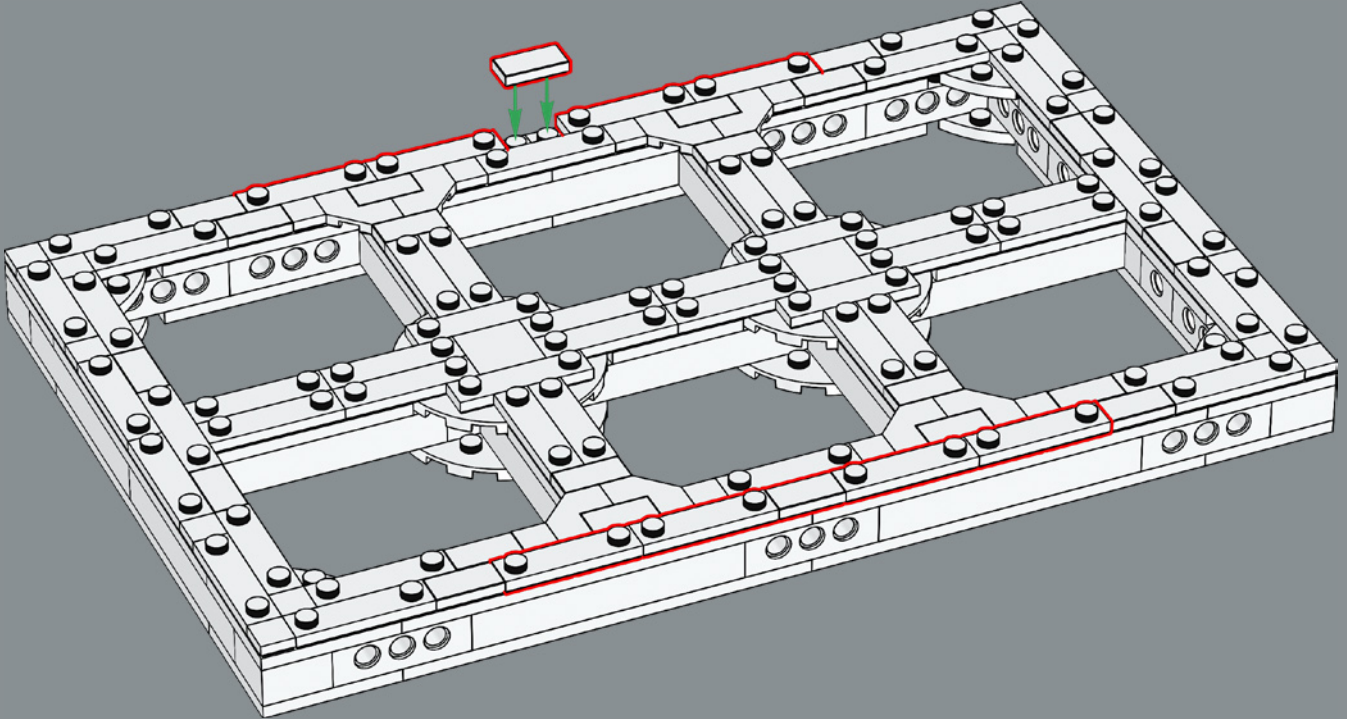



26

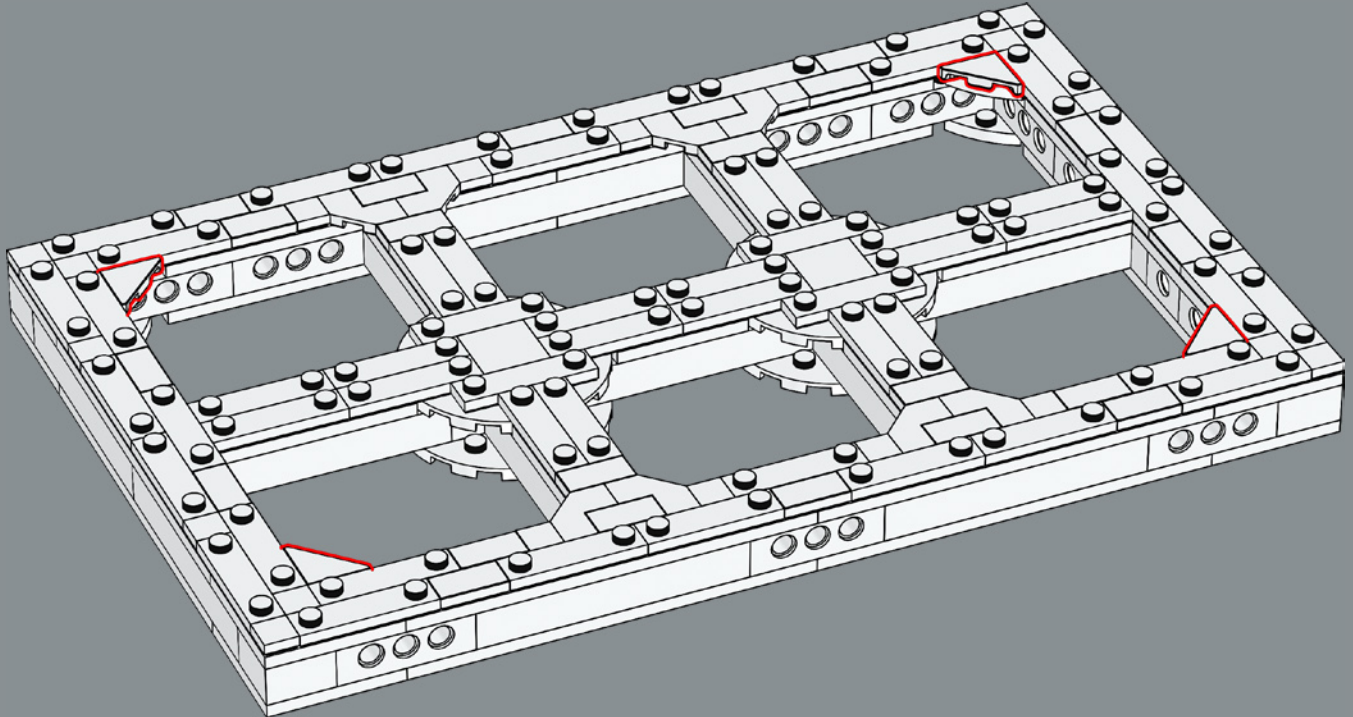

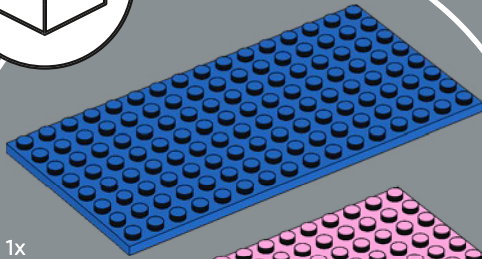
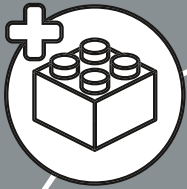

1x

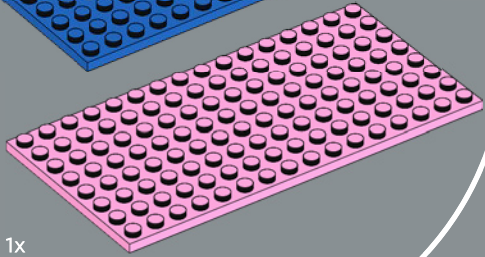

1x

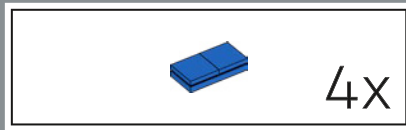

4x

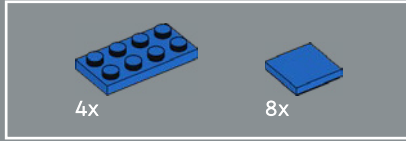

4x

8x

27

1

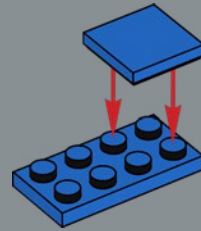

2

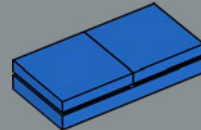

4x

3



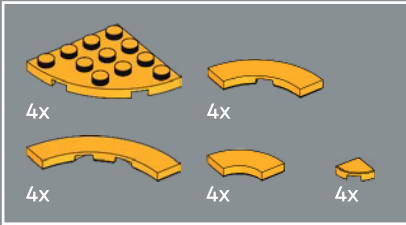
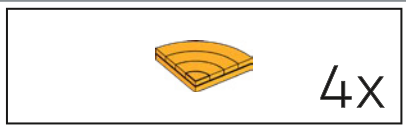

28

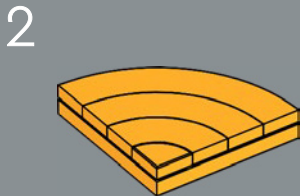
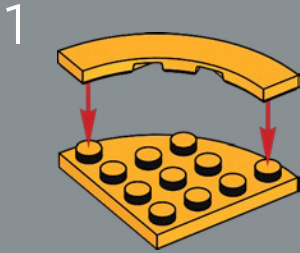

4x

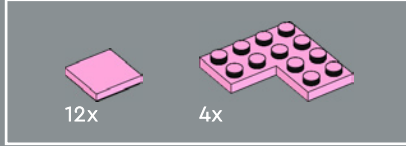
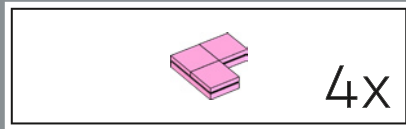

29

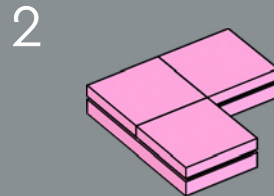
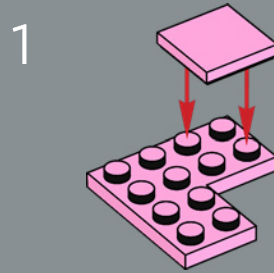

4x

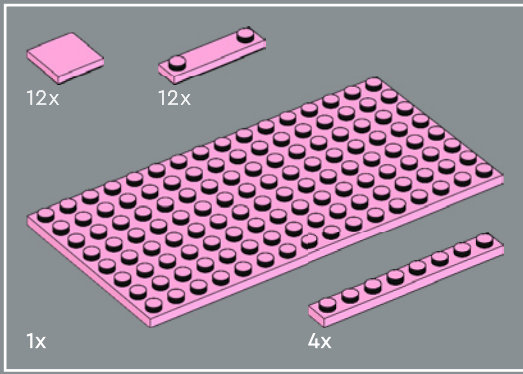

30

1

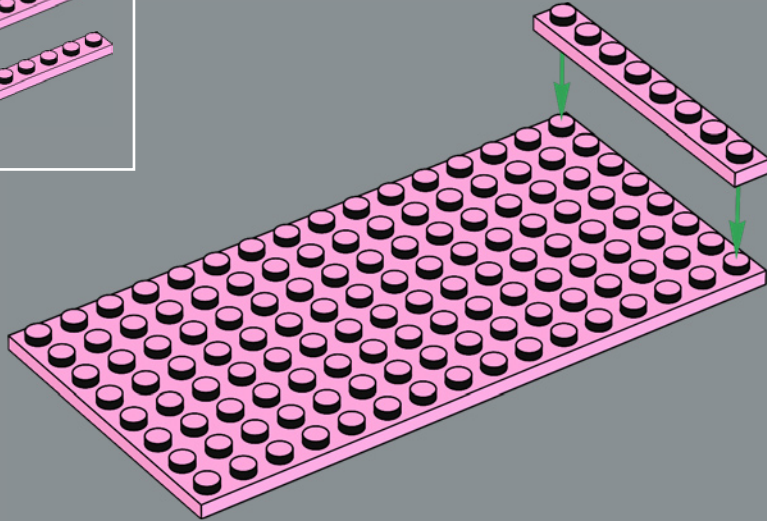

2

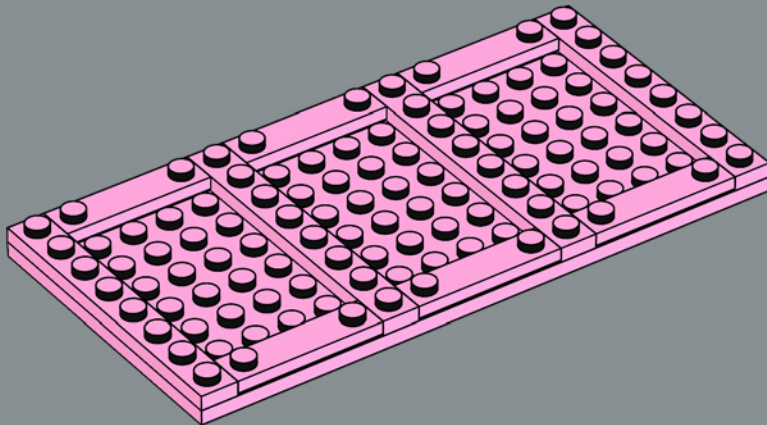

3

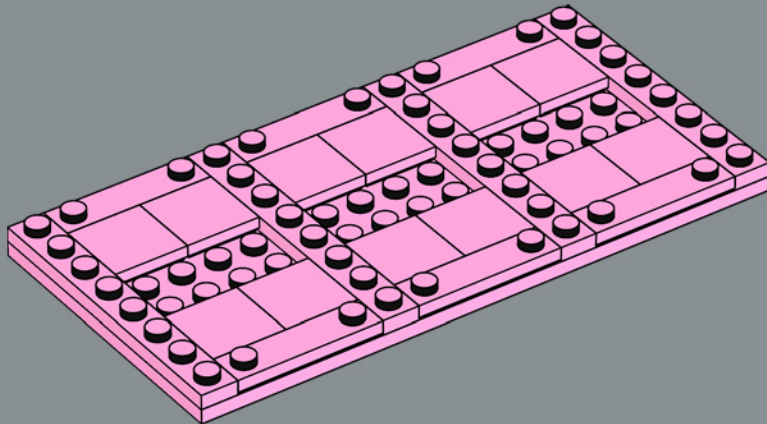

4

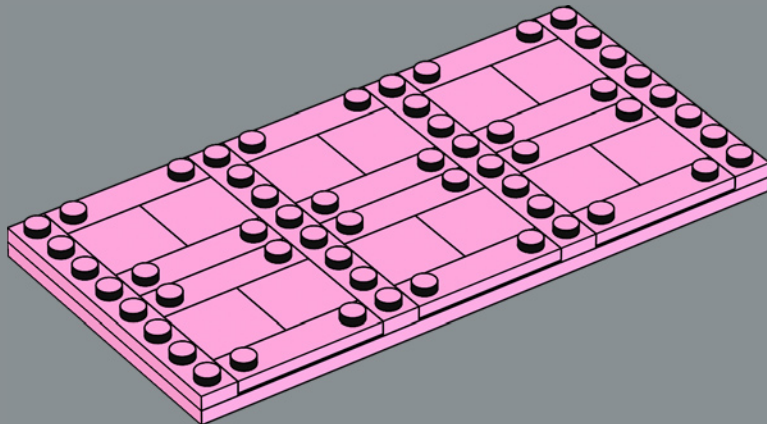

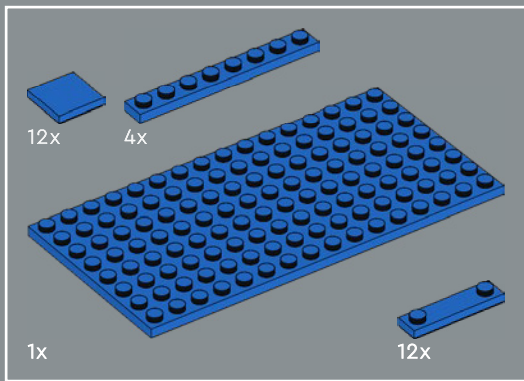

31

1

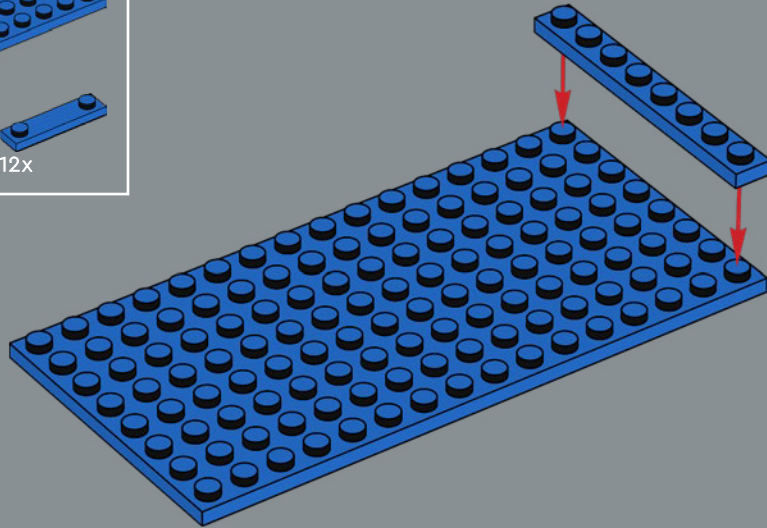

2

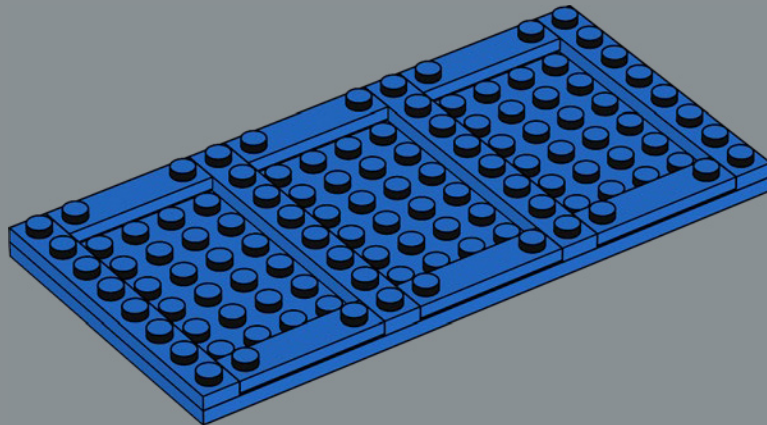

3

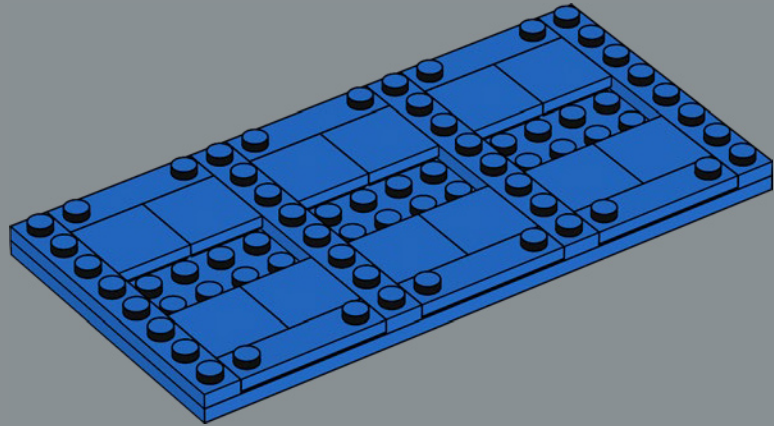

4

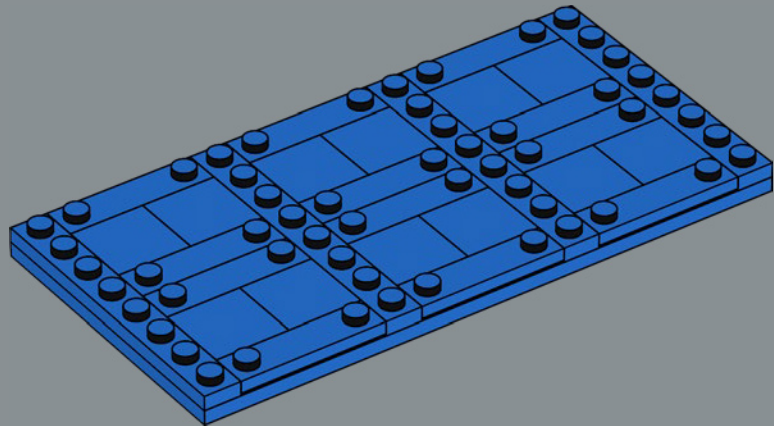

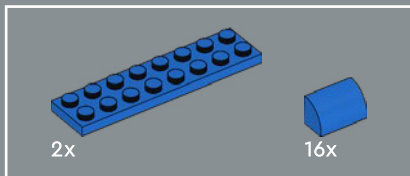
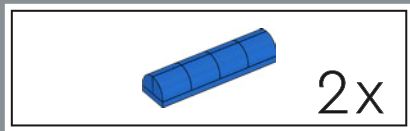

32

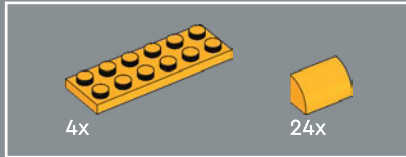
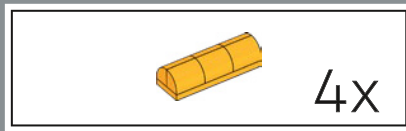
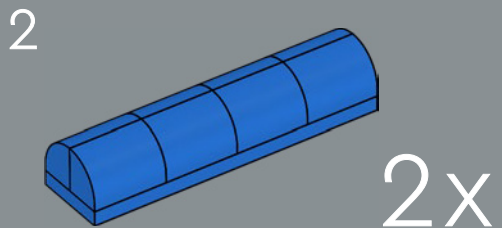
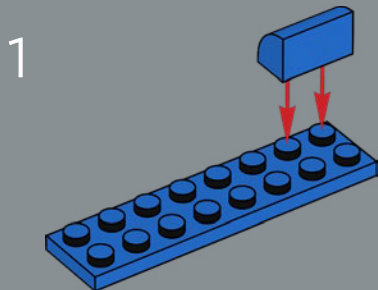

33

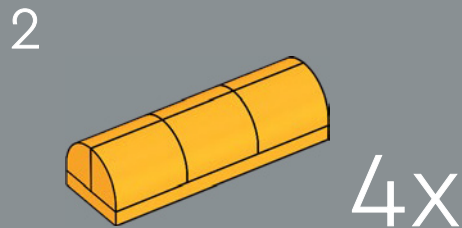
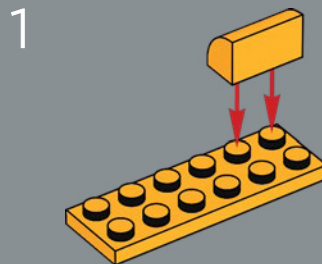

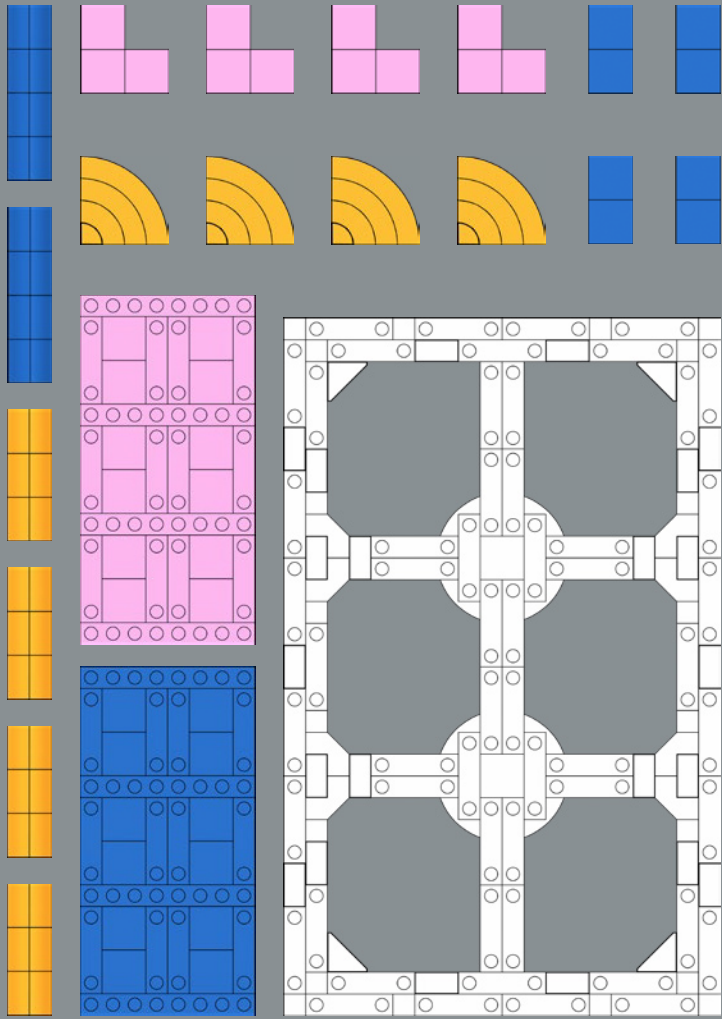

BALANCE

ÉQUILIBRE

EQUILIBRI

- Every element in your composition has a **visual weight**. By arranging elements symmetrically, or according to the **Rule of Thirds**, you can create a feeling of equilibrium.

Look for these elements in your set to help you explore this principle.

- Chaque élément de votre composition a un **poinds visuel**. En disposant les éléments de manière symétrique, ou selon la **règle des tiers**, vous pouvez créer un sentiment d'équilibre.

Recherchez ces éléments dans votre ensemble pour vous aider à explorer ce principe.

- Cada elemento de tu composición tiene un **peso visual**. Puedes crear una sensación de equilibrio distribuyendo los elementos simétricamente o de acuerdo con la **regla de los tercios**.

Fíjate en los siguientes elementos del set para explorar fácilmente este principio.

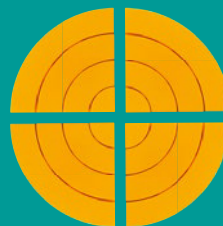

Citrus slice / Tranche d'agrumes /
Rebanada de fruta



Tube / Tubo



Chip / Éclat



Corner chip /
Éclat en coin /
Aperitivo triangular

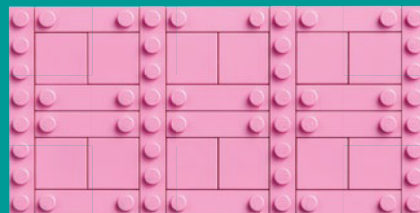

Platform / Plateforme / Plataforma

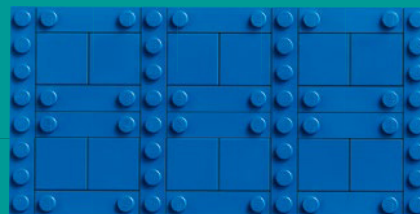

Tube / Tubo



Tube / Tubo

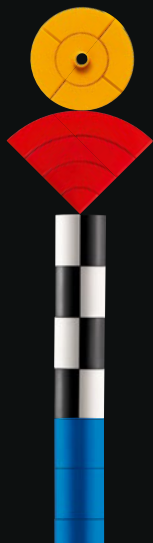

TIP THE SCALES!

- What happens to the balance in your artwork when you shift your elements around between the top, bottom, sides and center within the **Rule of Thirds** principle?

FAITES PENCHER LA BALANCE !

- Qu'arrive-t-il à l'équilibre de votre œuvre lorsque vous répartissez vos éléments entre le haut, le bas, les côtés et le centre selon le principe de la **règle des tiers** ?

¡INCLINA LA BALANZA!

- ¿Cómo cambia el equilibrio de tu obra de arte al desplazar los elementos entre las partes superior e inferior, los lados y el centro de acuerdo con la **regla de los tercios**?

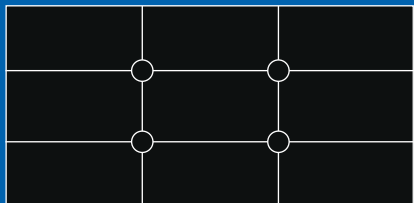
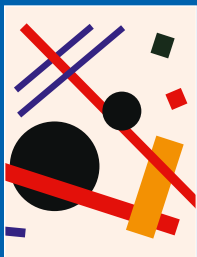
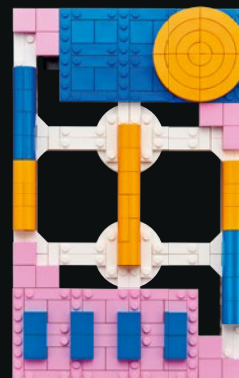
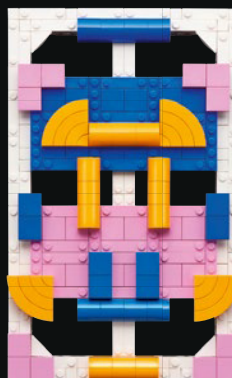

CALM OR FUN DISRUPTION?

- Unbroken, stable **Horizontal or Vertical Lines**, as well as placing 'weight' in the **lower two-thirds** of your composition help create stability and calm. Want a little more drama? Add some disruption, tip the scales and find your own balance!

HARMONIE OU DÉSORDRE AMUSANT ?

- Des **lignes horizontales ou verticales** constantes et ininterrompues, ainsi que le fait de placer du « poids » dans les **deux tiers inférieurs** de votre composition contribuent à créer stabilité et harmonie. Vous voulez un peu plus de drame ? Ajoutez du désordre, faites pencher la balance et trouvez votre propre équilibre !

¿CALMA O INQUIETUD DIVERTIDA?

- Las **líneas horizontales o verticales** estáticas e ininterrompidas, al igual que ubicar "peso" en los **dos tercios inferiores** de tu composición, contribuyen a crear estabilidad y calma. ¿Buscas un poco de dramatismo? ¡Agrega algún elemento que genere inquietud, inclina la balanza y encuentra tu propio equilibrio!



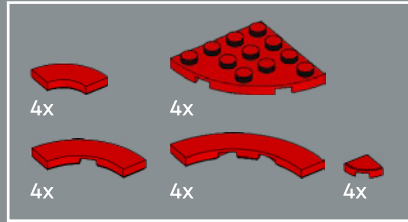
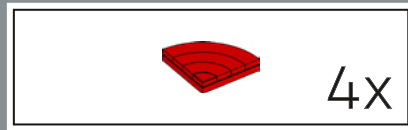

34

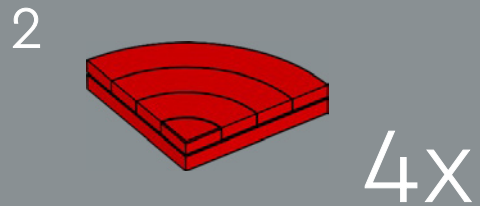
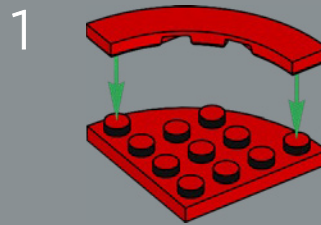

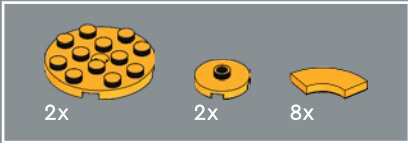
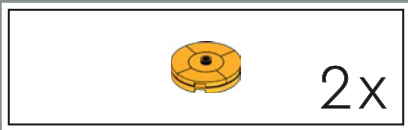

35

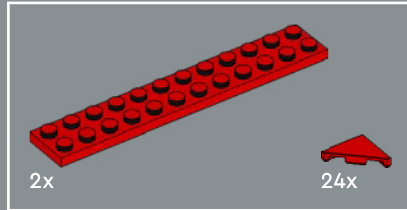
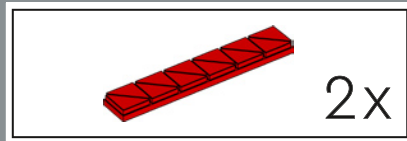
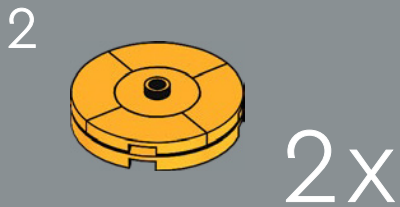
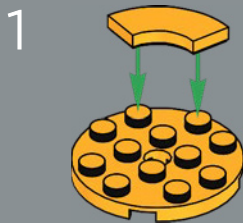

36

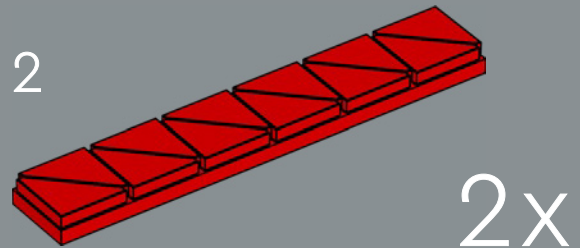
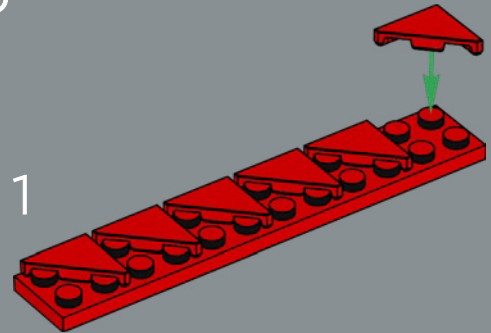

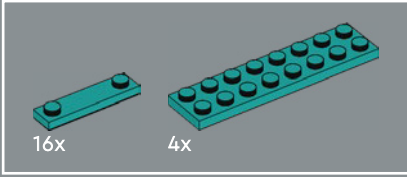
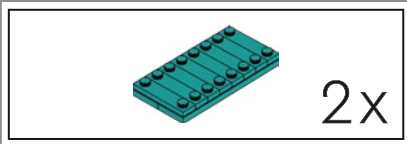

37

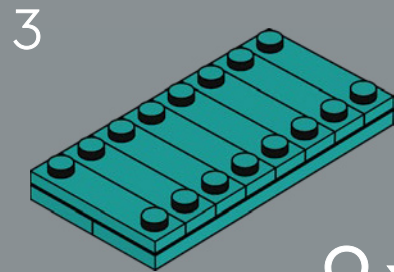
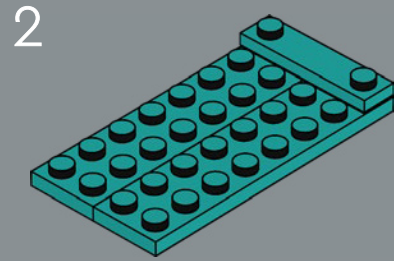
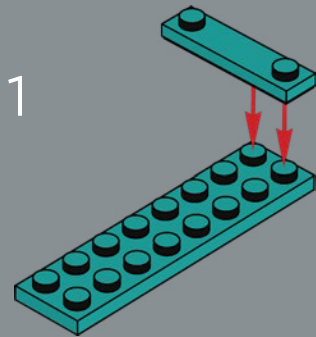

2x

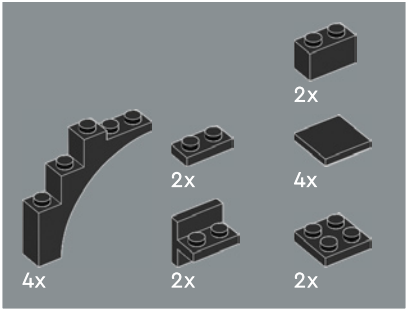
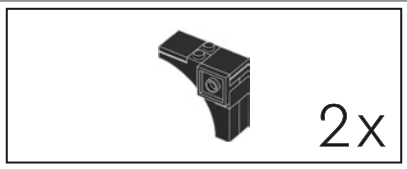

38

1

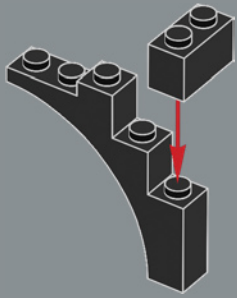

2

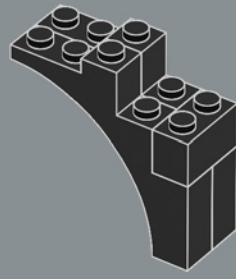

3

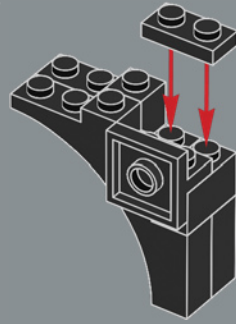

4

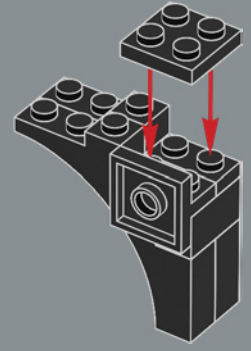

5

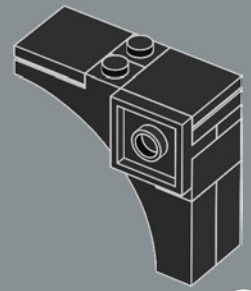

2x

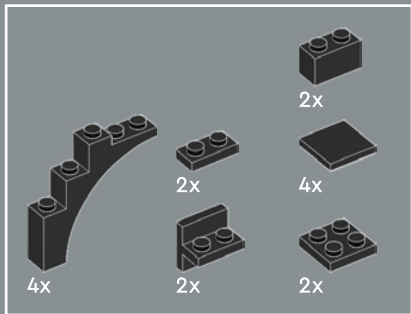
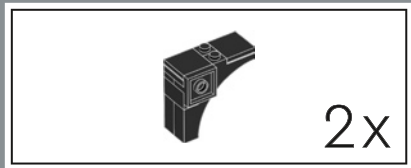

39

1

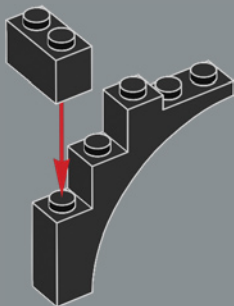

2

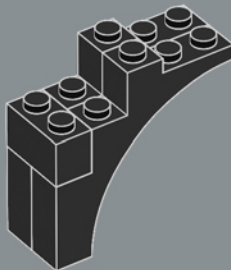

3

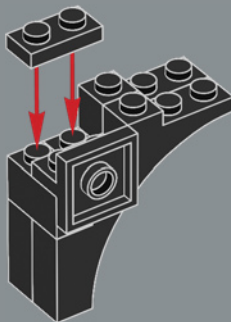

4

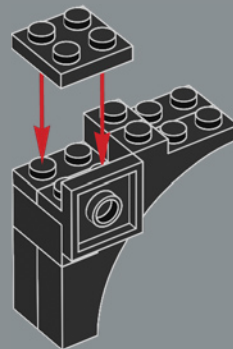

5

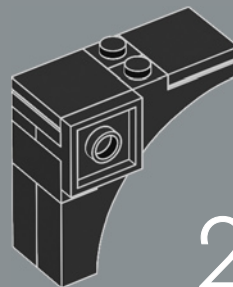

2x

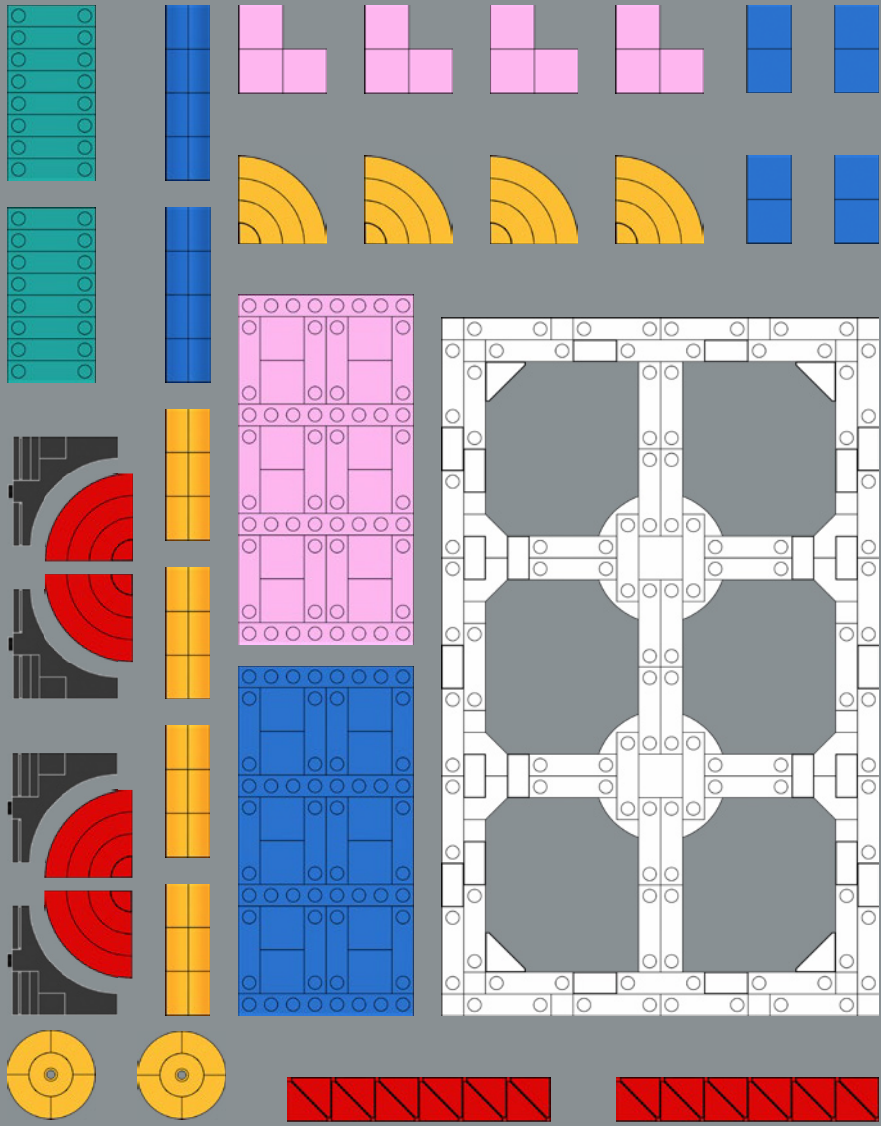

RHYTHM

RYTHME

RITMO

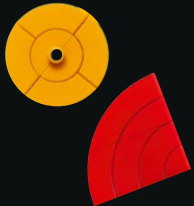
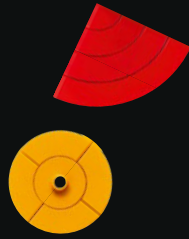

- Repetition of shapes and colors creates visual dynamics and tempo for the viewer's eye to follow. By making **Every Corner Unique**, you create a variety of interest points that brings the composition to life.

- La répétition des formes et des couleurs crée une dynamique visuelle et un rythme que l'œil de l'observateur doit suivre. En rendant **chaque coin unique**, vous créez une variété de curiosités qui donnent vie à la composition.

- Repetir formas y colores crea una dinámica visual y un compás que el ojo del espectador puede interpretar. Al **diferenciar bien cada esquina**, creas un abanico de puntos de interés que aportan vida a la composición.

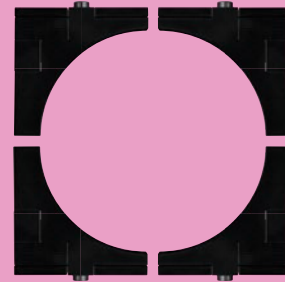

Half moon/Demi-Lune/Media luna



Strip/Bande/Franja

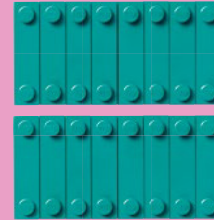

Paddle/Rame/Remo



Dot/Point/Punto

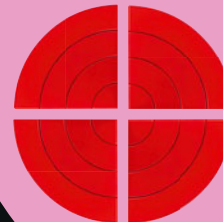

Tomato slice/
Tranche de tomate/
Rebanada de tomate

CREATING COHESION

● How do you apply the **Every Corner Unique** technique? Use the elements you have built and experiment with different shapes and colors to give your artwork a sense of cohesion. Use as many or as few elements as you like!

CRÉER LA COHÉSION

● Comment appliquez-vous la technique « **Chaque coin est unique** » ? Utilisez les éléments que vous avez construits et jouez avec différentes formes et couleurs pour donner à votre œuvre une certaine cohésion. Utilisez autant ou aussi peu d'éléments que vous le souhaitez !

CREAR COHESIÓN

● ¿Cómo se aplica la técnica que permite **diferenciar bien cada esquina**? Usa los elementos que construiste y experimenta con diferentes formas y colores para darle a tu obra de arte cierto sentido de cohesión. ¡Usa tantos o tan pocos elementos como quieras!

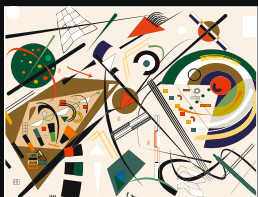
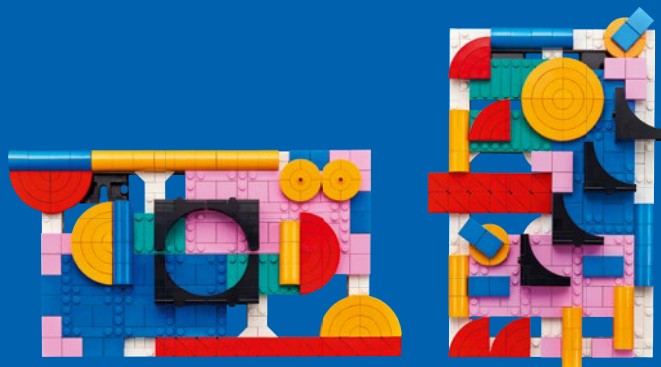

SHAPES AND SIZES

● Organic shapes help create flow, rhythm and maybe just the right amount of chaos in a composition, whereas geometric shapes usually create a more structured, calm expression. Play with the sizes of your shapes, too, if you want to draw attention to specific elements.



FORMES ET TAILLES

● Les formes organiques aident à créer un flot, un rythme et peut-être juste la bonne dose de chaos dans une composition, alors que les formes géométriques créent généralement une image plus structurée et harmonieuse. Jouez également avec la taille de vos formes, si vous voulez attirer l'attention sur des éléments spécifiques.

FORMAS Y TAMAÑOS

● Las formas orgánicas contribuyen a crear fluidez, ritmo y, tal vez, la cantidad justa de caos en una composición, mientras que las formas geométricas, por lo general, dan lugar a una expresión más estructurada y calmada. Juega también con el tamaño de tus formas si quieres llamar la atención sobre elementos específicos.

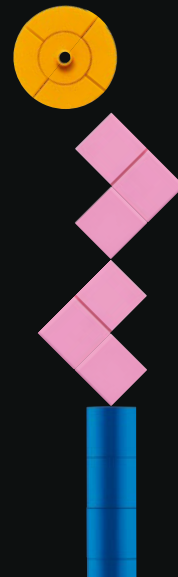

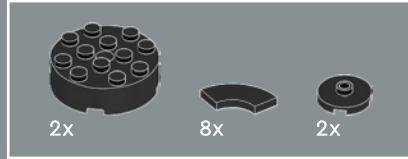
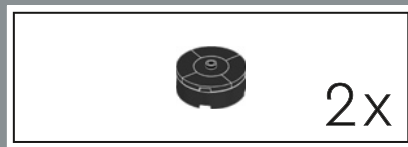

40

1

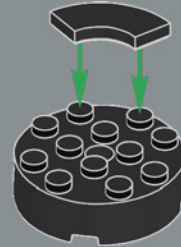

2

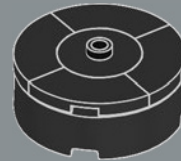

2x

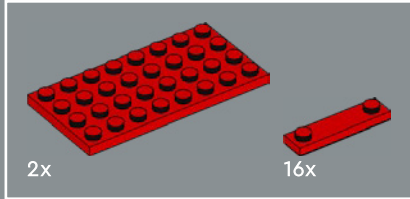

41

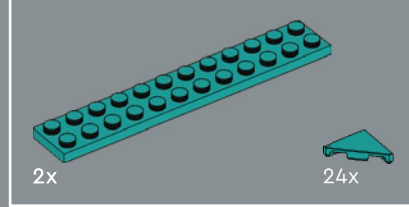
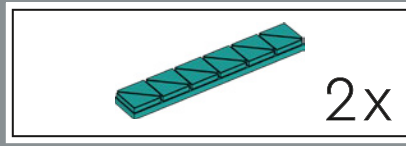
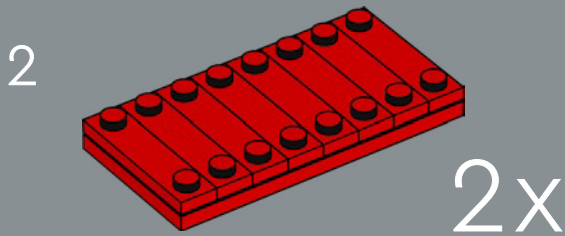
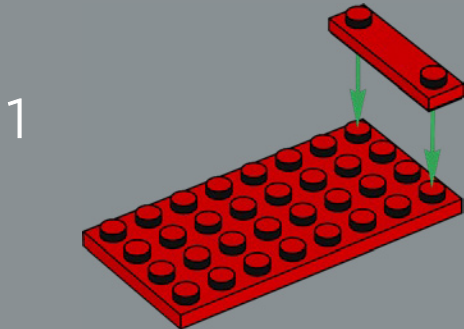

42

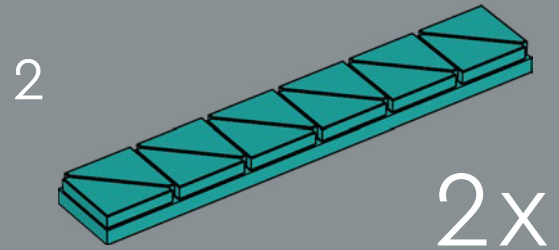
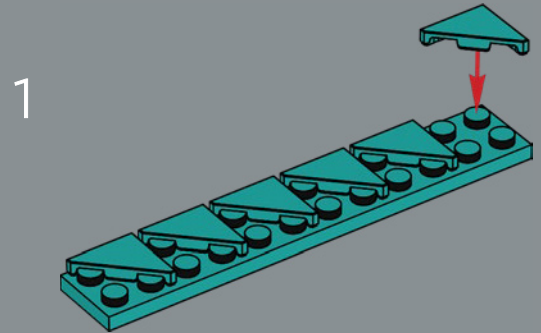

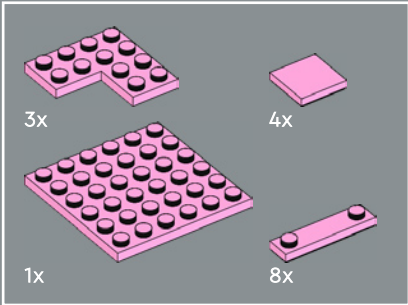
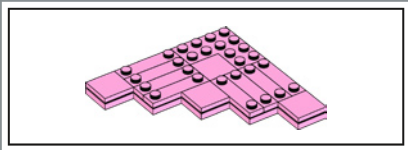

43

1

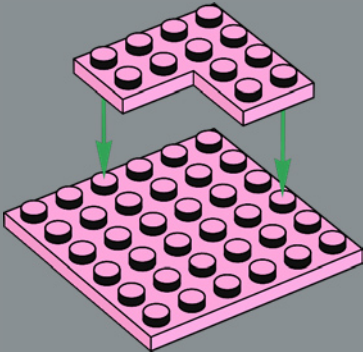

2

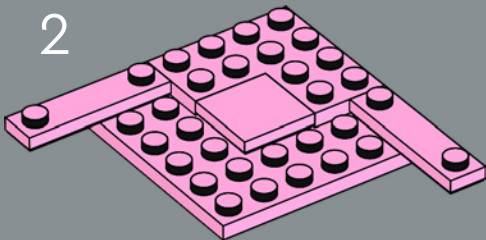

3

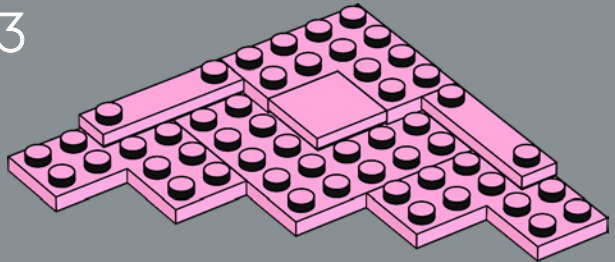

4

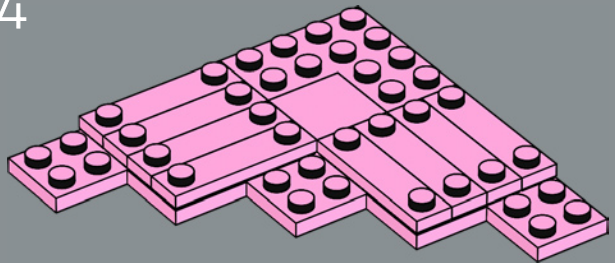

5

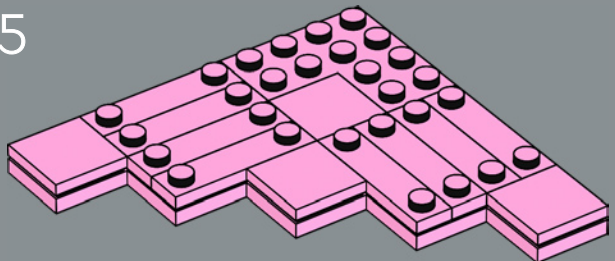

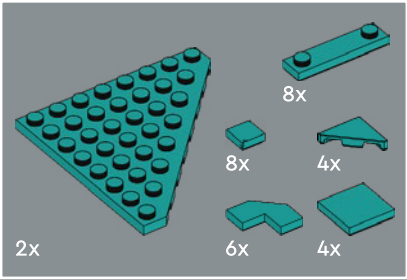
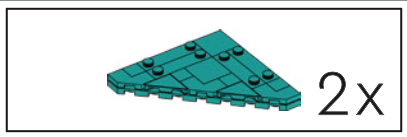

44

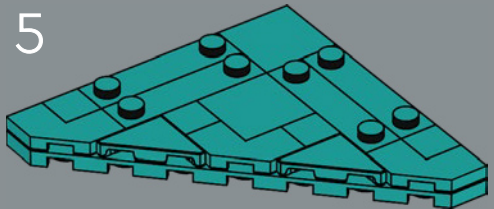
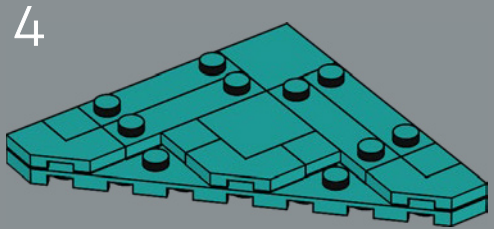
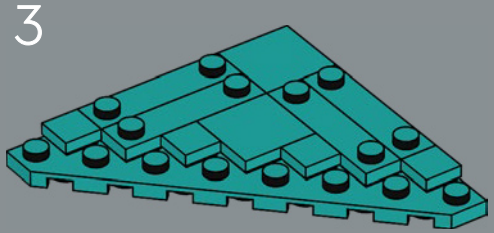
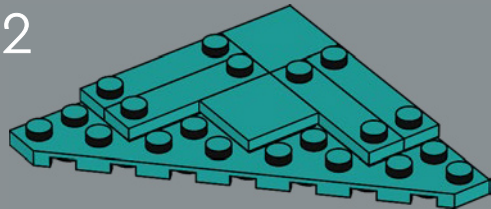
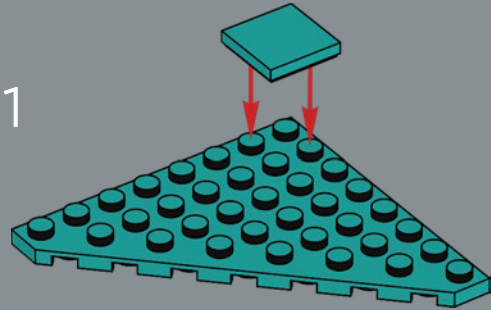

2x 63

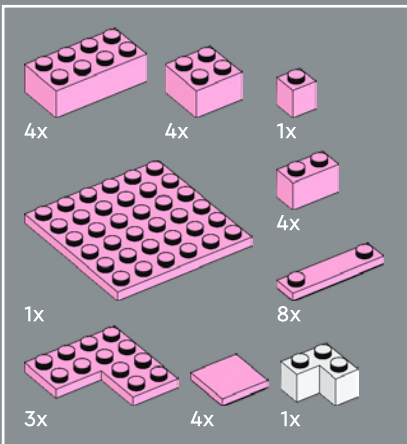
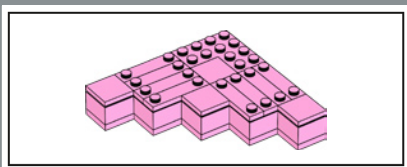

45

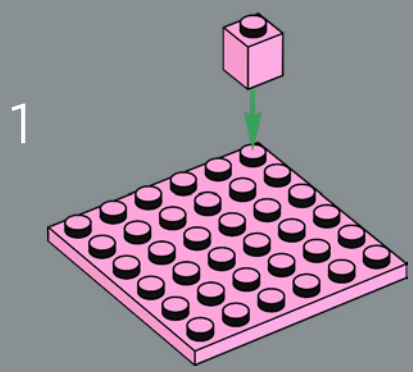

2

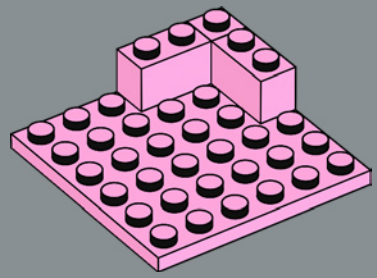

3

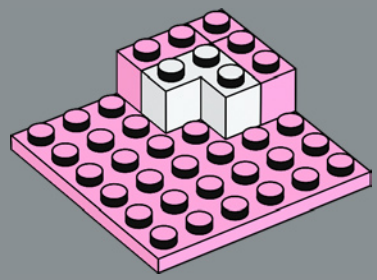

4

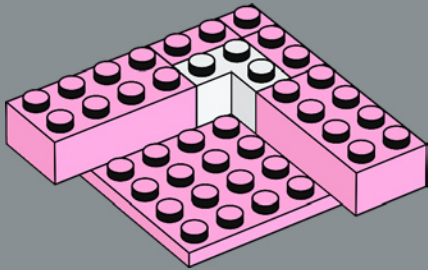

5

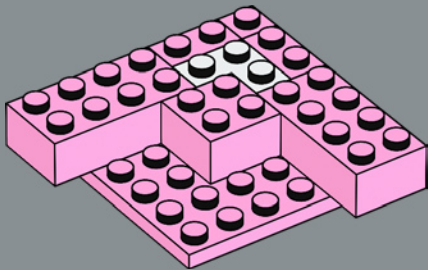

6

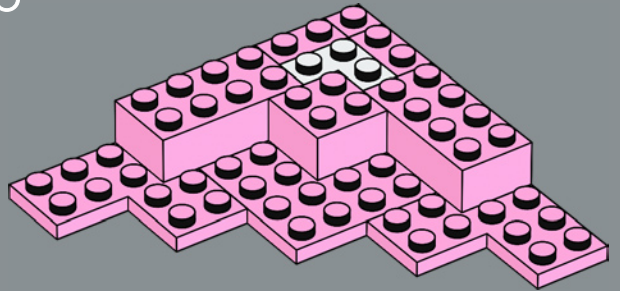

7

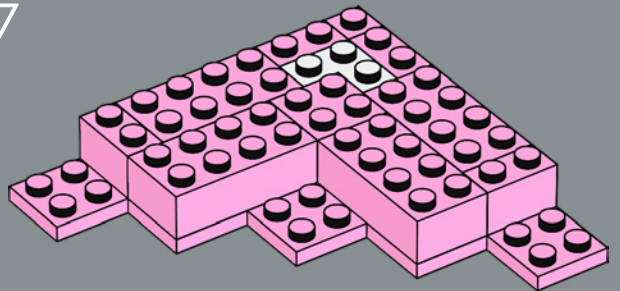

8

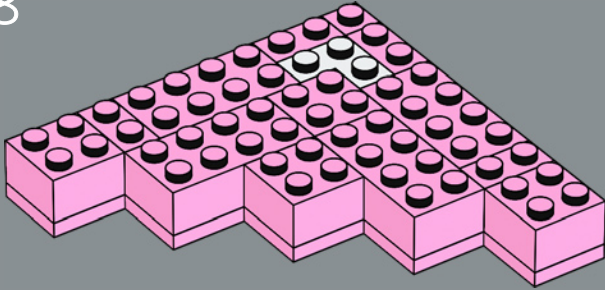

10

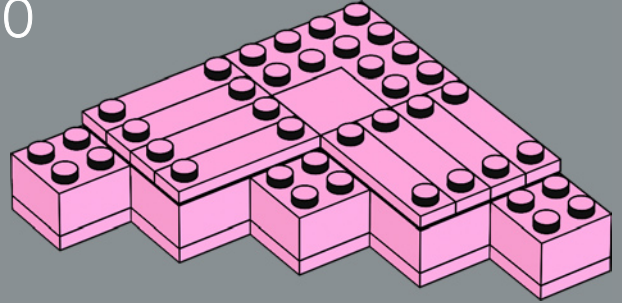

9

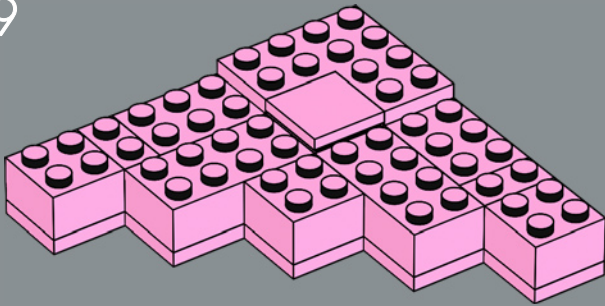

11

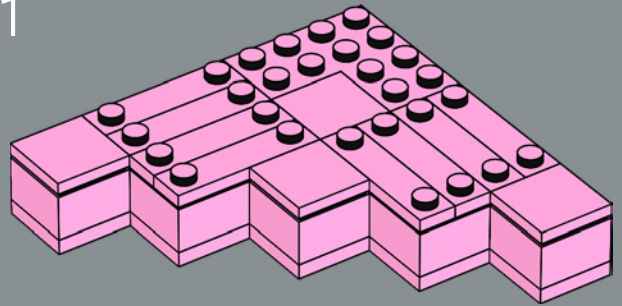

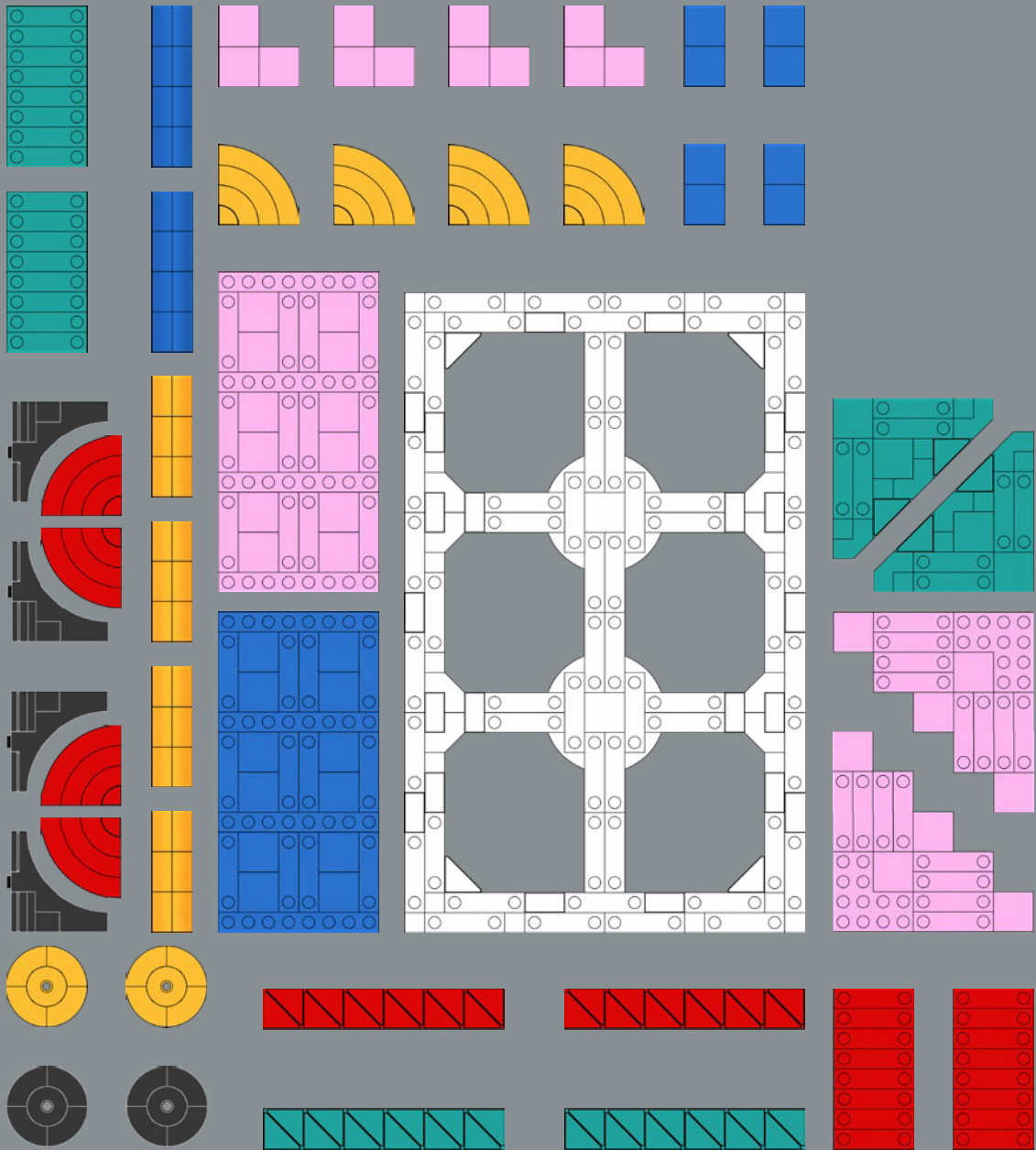

MOVEMENT MOUVEMENT MOVIMIENTO



- Using your elements to create **Diagonal Lines** draws the viewer's eye and brings a sense of movement and direction to your artwork.

Whether they're explicit or more subtle lines, they can take the viewer on a journey to different destinations around the artwork.

- L'utilisation de vos éléments pour créer des **lignes diagonales** attire l'œil de l'observateur et donne une impression de mouvement et de direction à votre œuvre.

Les lignes, qu'elles soient nettes ou plus subtiles, peuvent faire voyager l'observateur vers différentes destinations dans l'œuvre d'art.

- Usar elementos para crear **líneas diagonales** atrae la atención del espectador y le aporta una sensación de movimiento y dirección a tu obra de arte.

Ya sea que se trate de líneas visualmente explícitas o más sutiles, pueden llevar al observador de viaje hacia diferentes destinos alrededor de la obra.

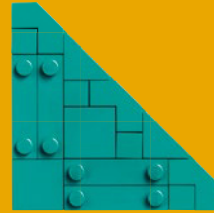
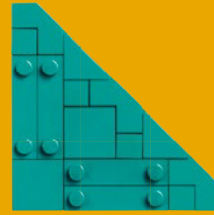

Nacho



Dot/Point/Punto



Strip/Bande/Franja

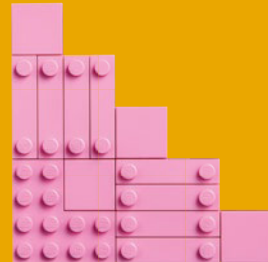

Step/Escalier/Paso

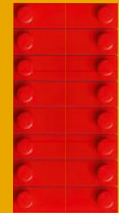

Paddle/Rame/
Remo

PLACEMENT AND CONTRASTS

- Use your elements to shape colorful paths and transitions between modules or through different color blocks. What happens when you place your **Diagonal Lines** behind other elements versus in front of them? Give it a try!

DISPOSITION ET CONTRASTES

- Utilisez vos éléments pour former des chemins et des transitions colorés entre les modules ou à travers différents blocs de couleur. Que se passe-t-il lorsque vous placez vos **lignes diagonales** derrière d'autres éléments plutôt que devant eux ? Faites-en l'essai !

UBICACIÓN Y CONTRASTES

- Usa tus elementos para formar senderos de colores y transiciones entre módulos o a través de diferentes bloques de color. ¿Qué sucede al insertar **líneas diagonales** detrás de otros elementos en comparación con lo que pasa al colocarlas encima de ellos? ¡Inténtalo!

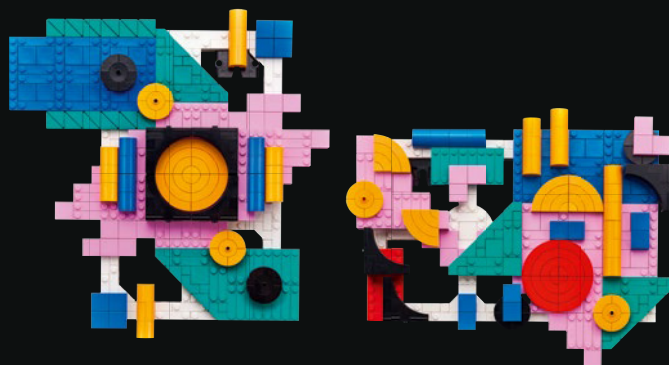

WHAT'S YOUR PERSPECTIVE?

- Color-blocking, placement of contrasting colors and light and dark shades can help you create focal points, depth and perspective in your artwork. And now, for the final touch, give your masterpiece an intriguing name that really draws the viewer in!

QUELLE EST VOTRE PERSPECTIVE ?

- Le blocage des couleurs, la disposition des couleurs contrastantes et des nuances claires et foncées peuvent vous aider à ajouter des points focaux, de la profondeur et de la perspective à votre œuvre. Et maintenant, pour la touche finale, donnez à votre chef-d'œuvre un nom intrigant qui captivera vraiment l'observateur !

¿CUÁL ES TU PUNTO DE VISTA?

- Componer bloques de color, ubicar contrastes cromáticos y usar luces y sombras puede ser de ayuda para crear puntos de atención, profundidad y perspectiva dentro de tu obra de arte. Y ahora, como toque final, ¡ponle a tu obra maestra un nombre misterioso que atraiga e interese al observador!

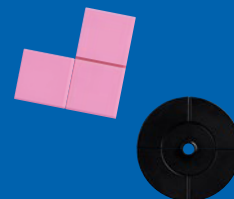

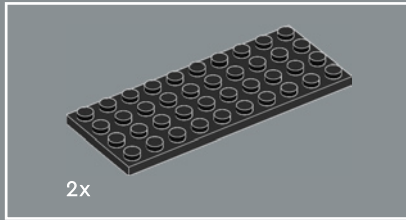
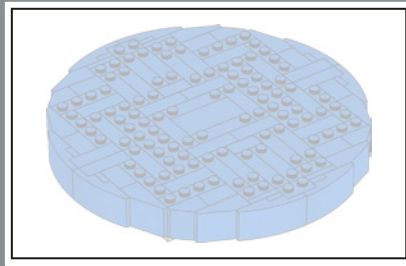

46

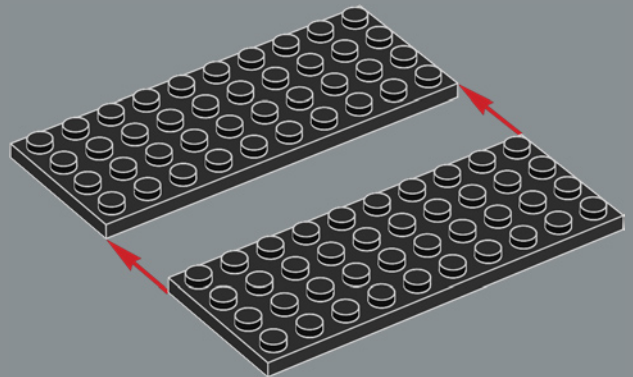

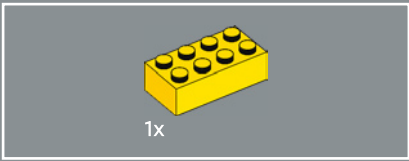

47

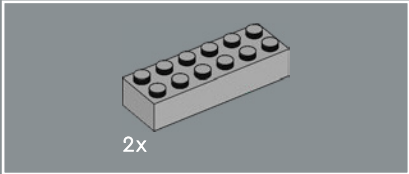
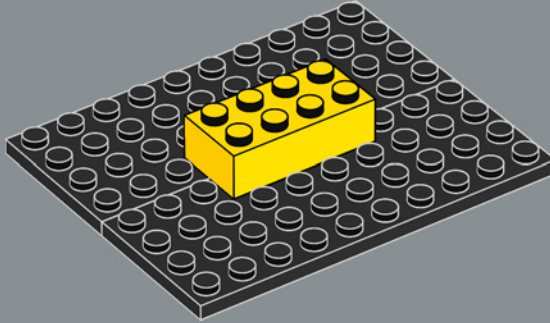

48

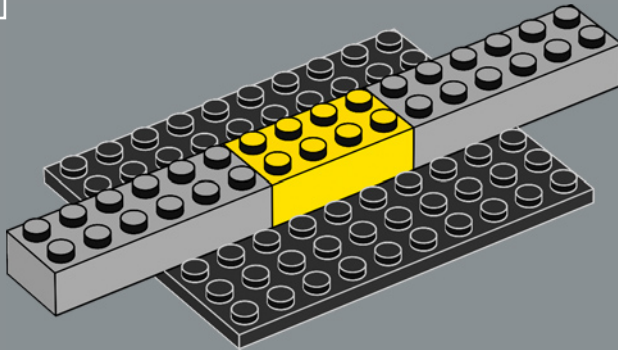

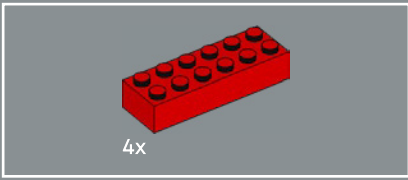

49

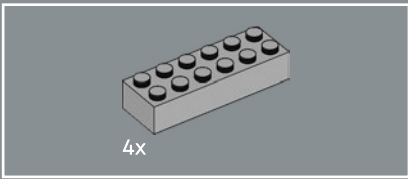
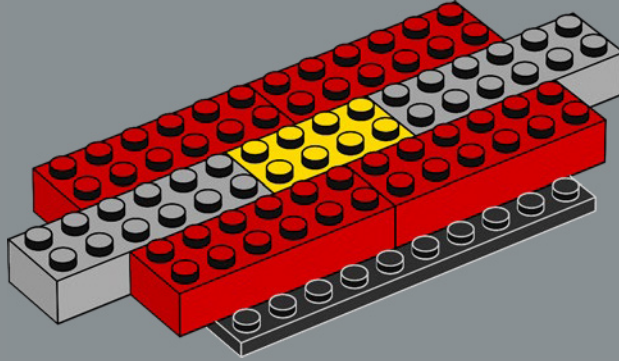

50

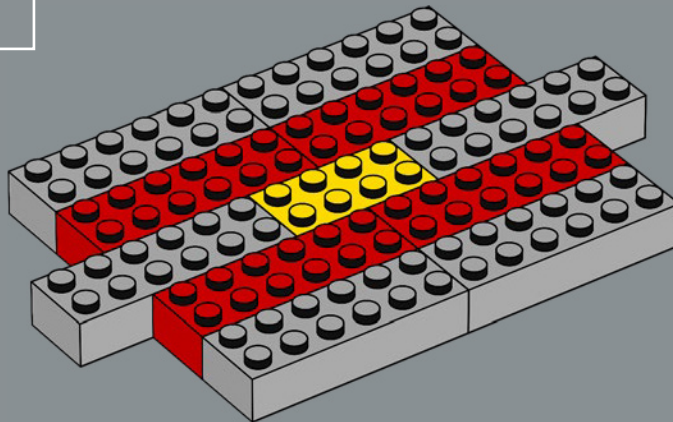

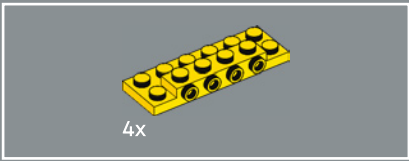

51

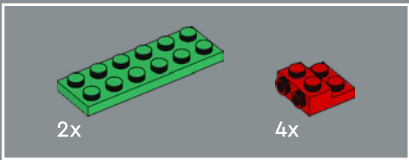
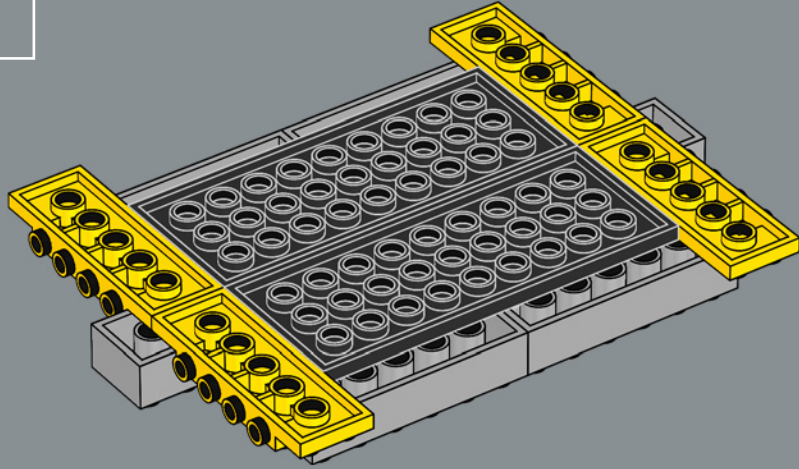

52

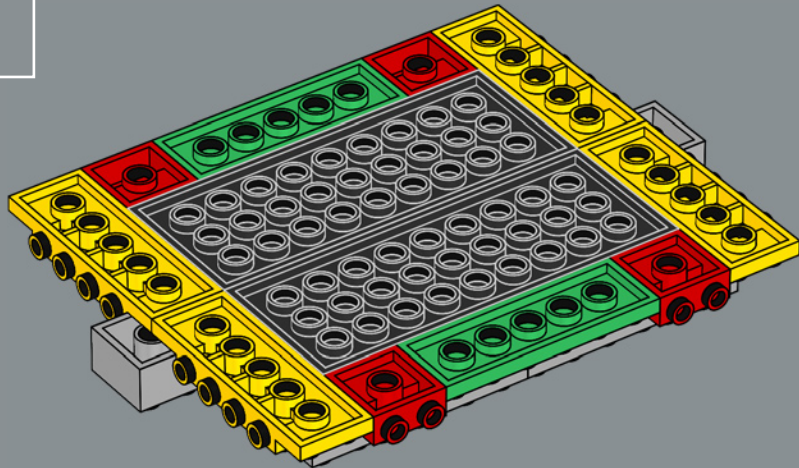

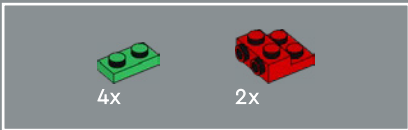

53

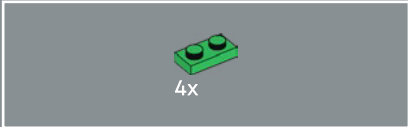
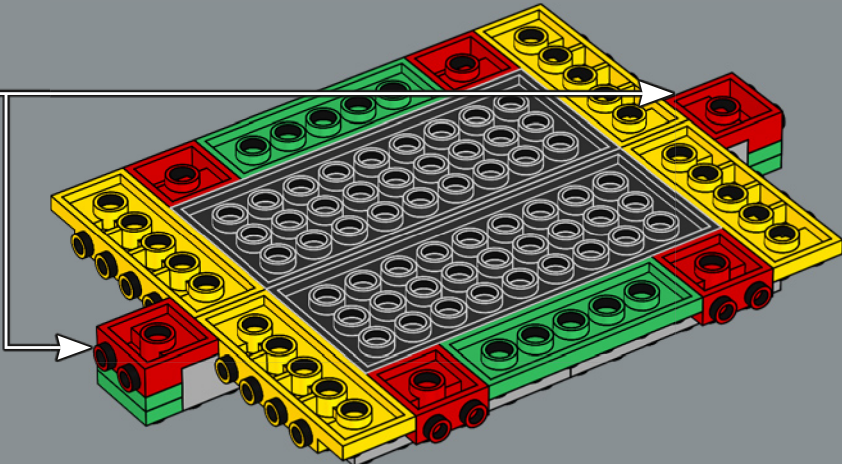
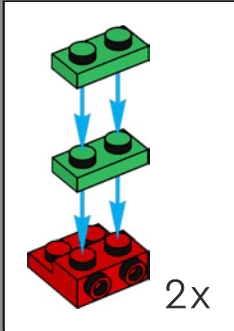

54

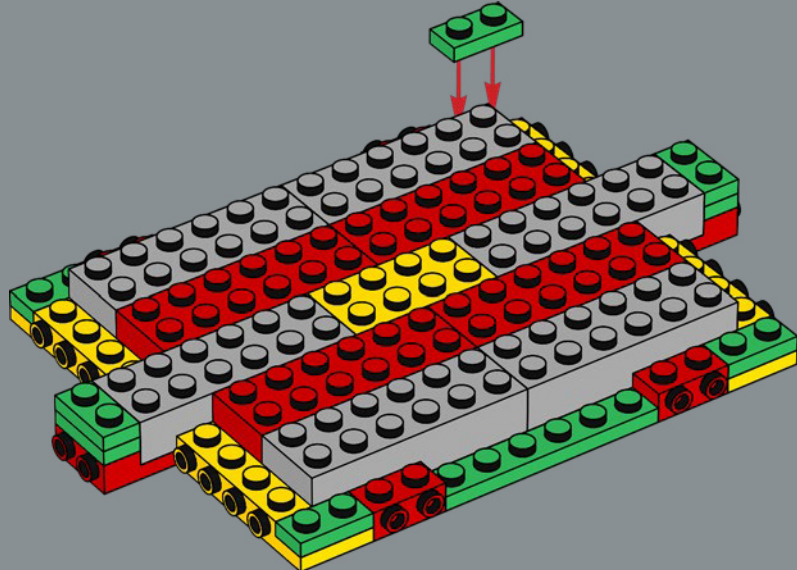

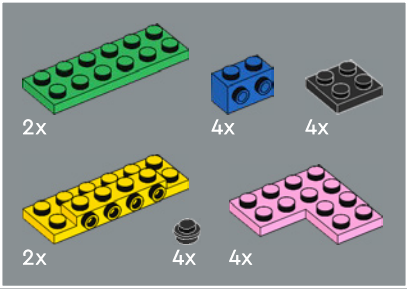
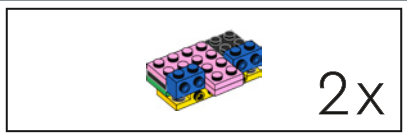

55

1

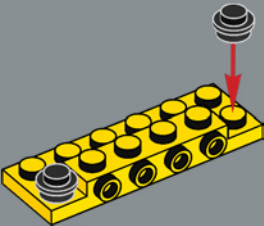

2

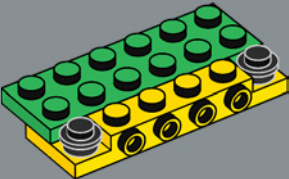

3

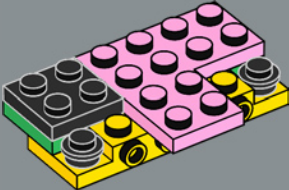

4

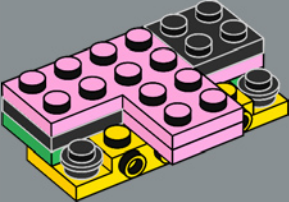

5

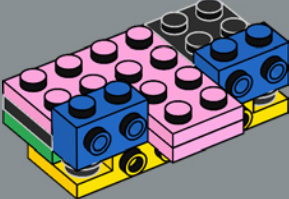

2x

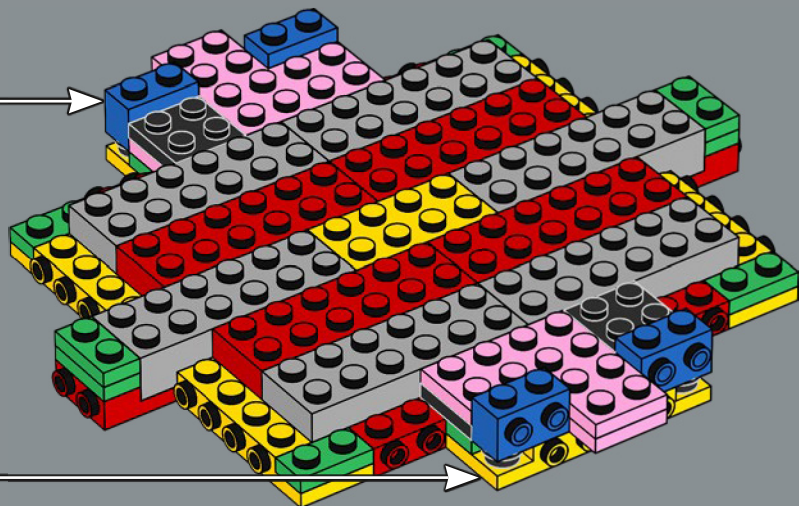

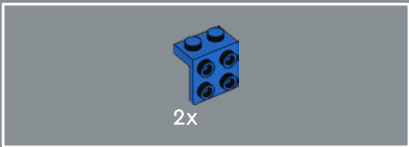

56

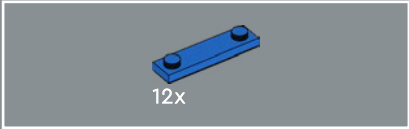
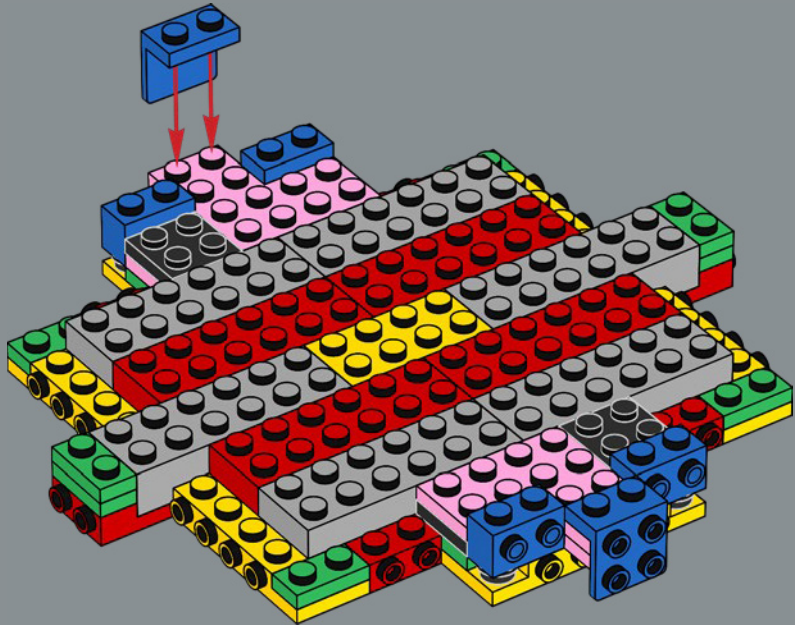

57

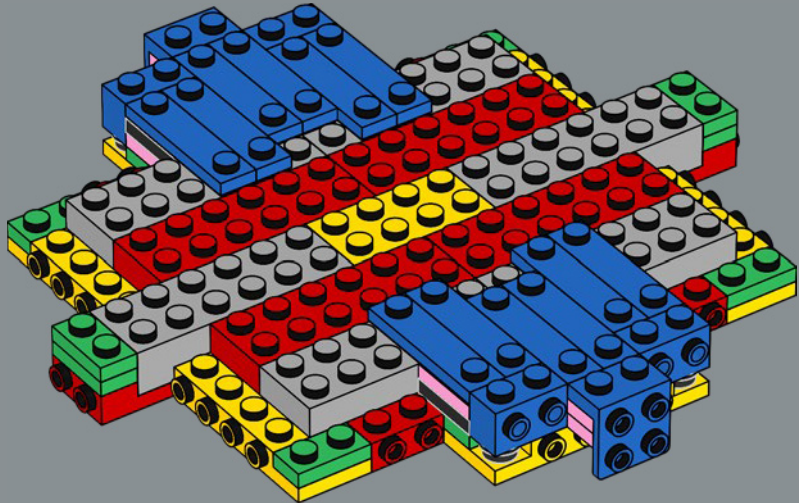

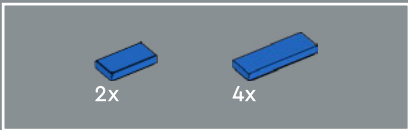

58

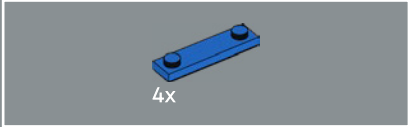
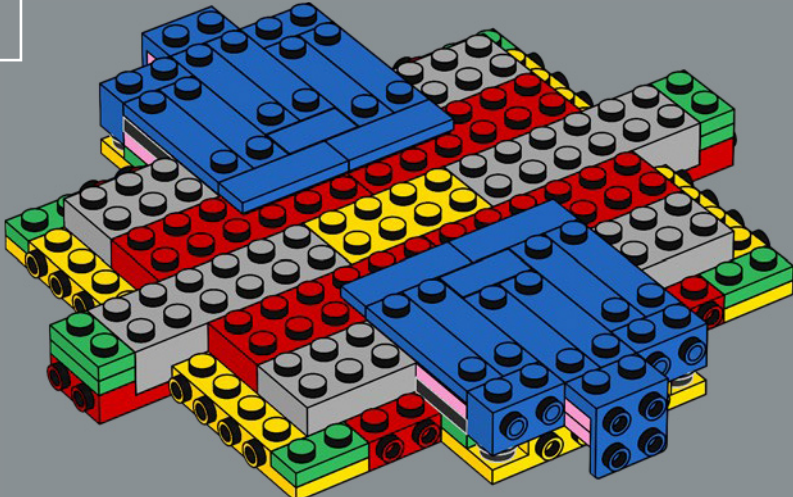

59

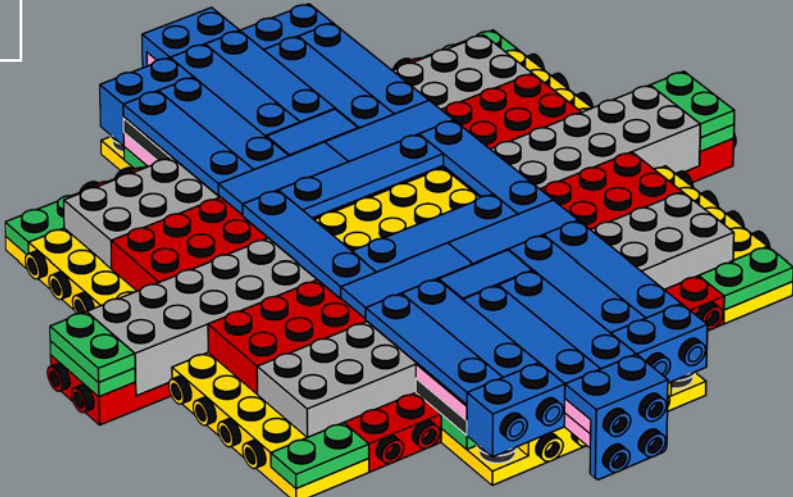

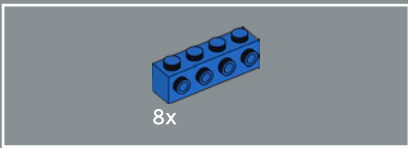

60

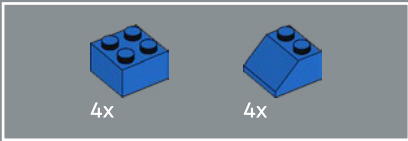
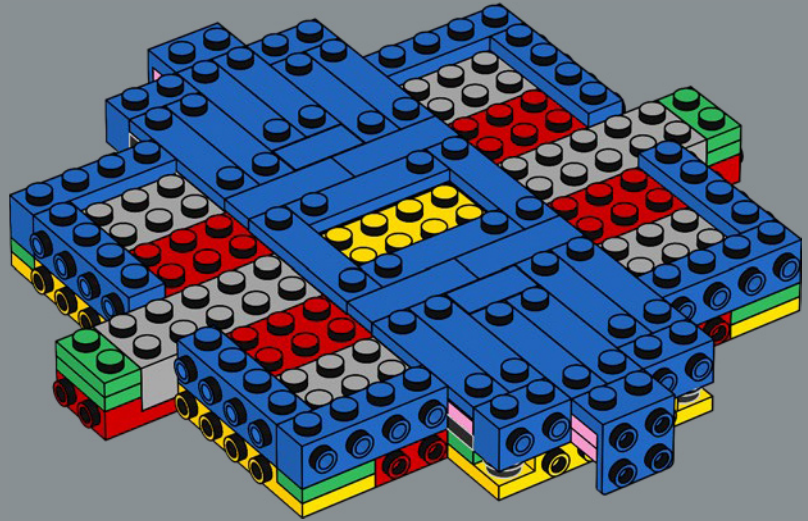

61

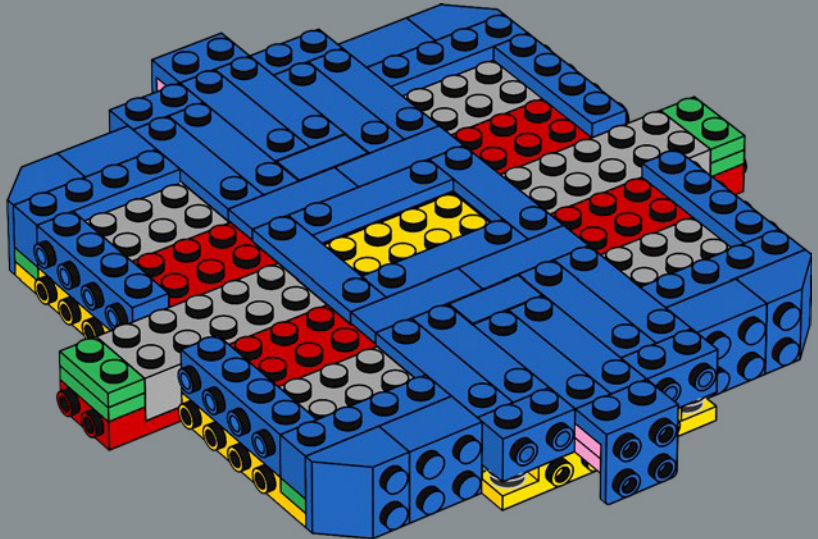

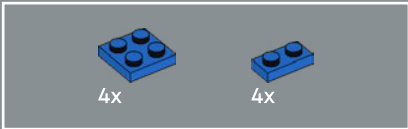

62

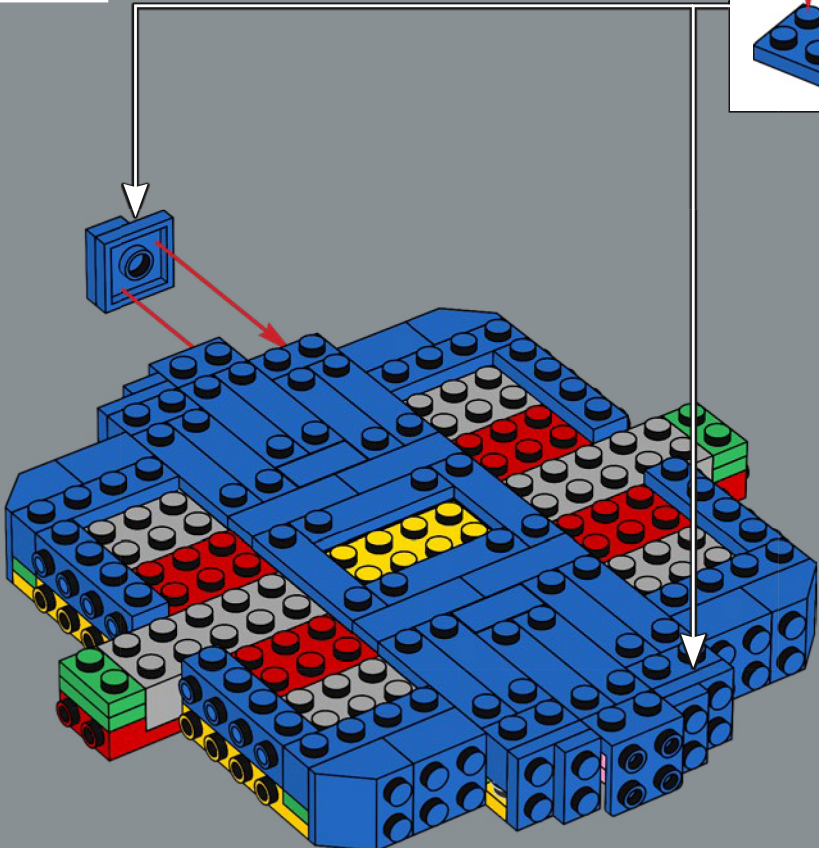
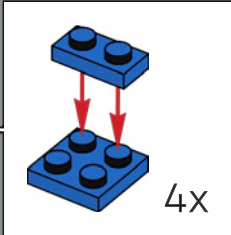

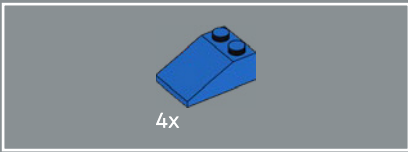

63

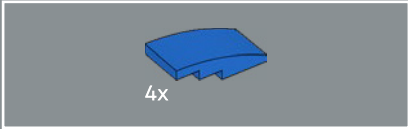
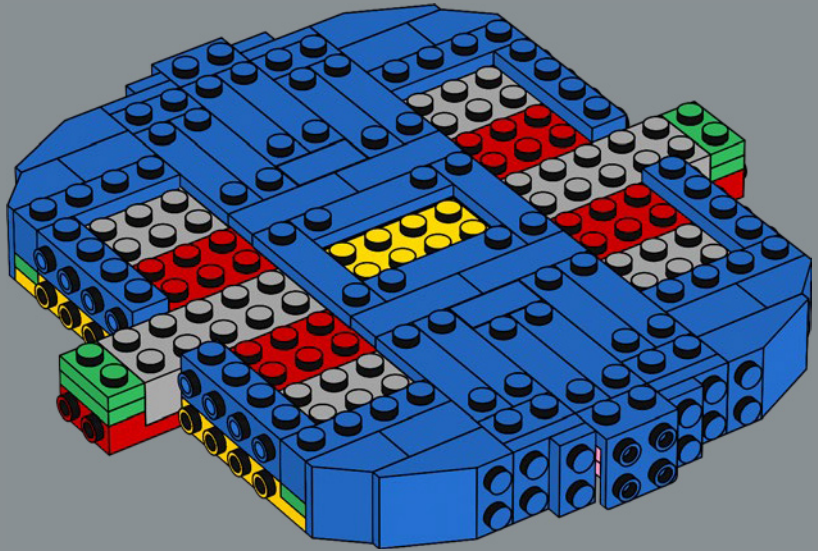

64

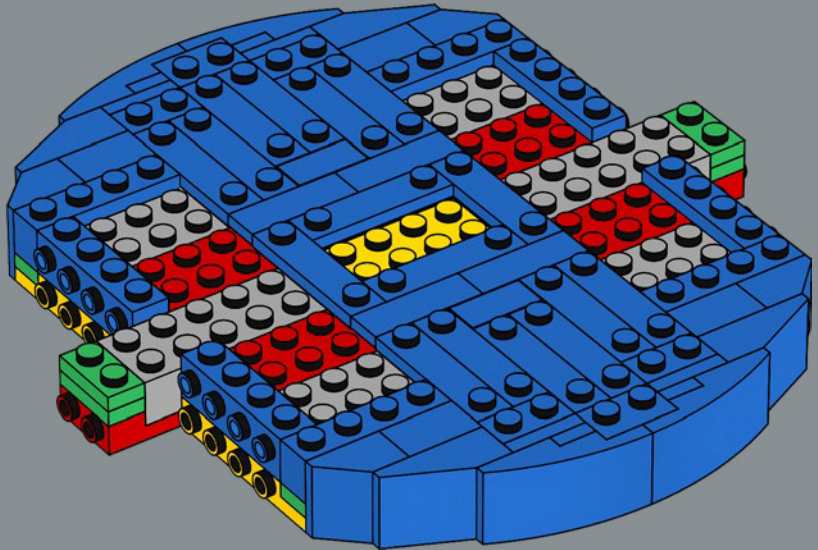

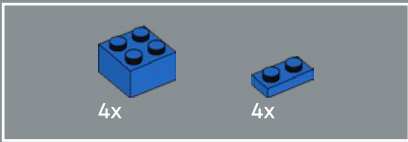

65

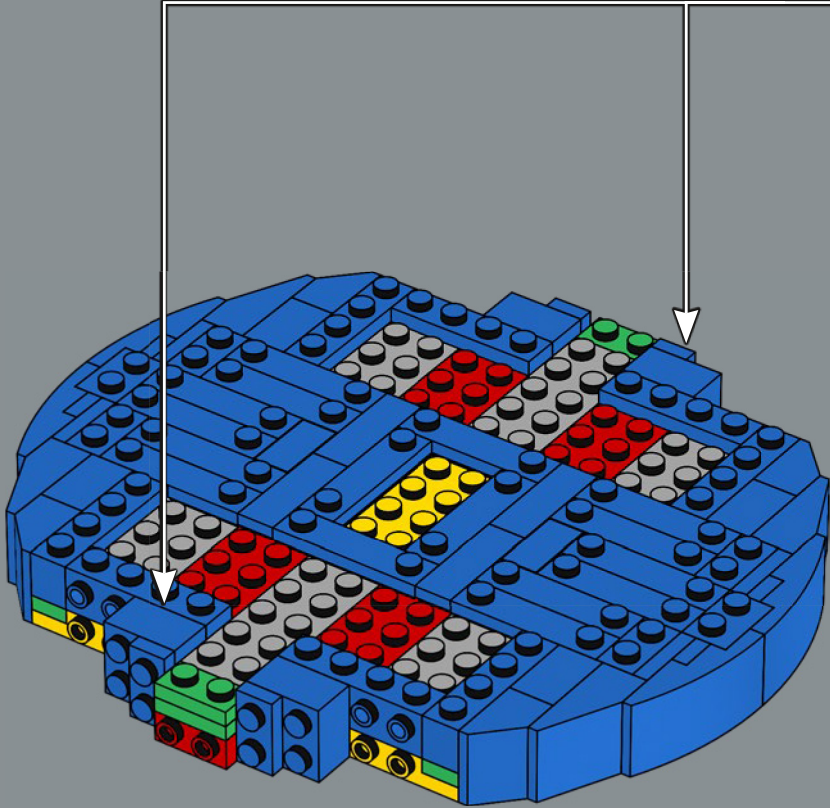
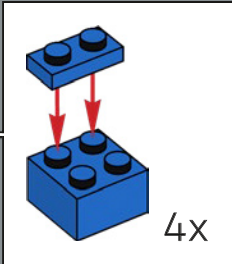

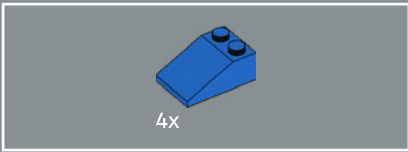

66

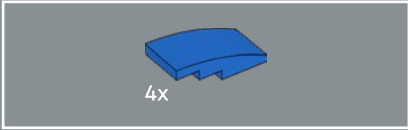
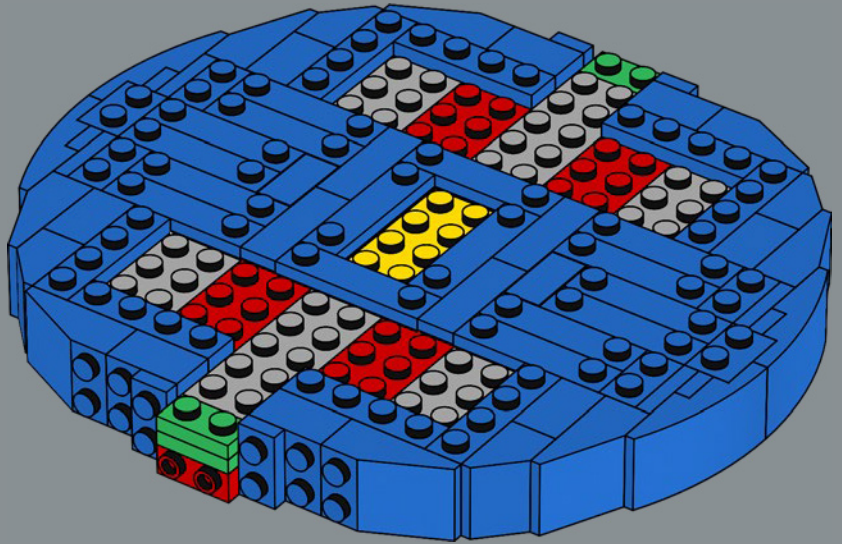

67

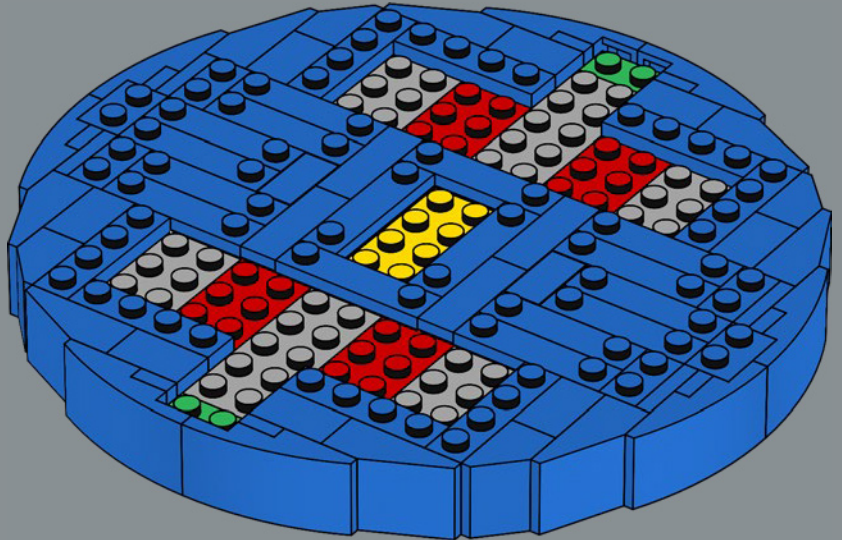

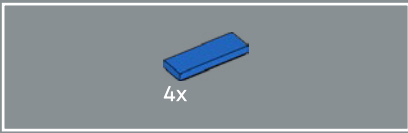

68

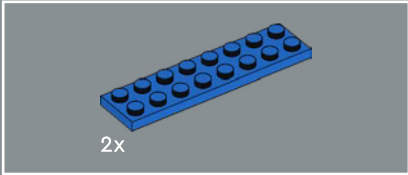
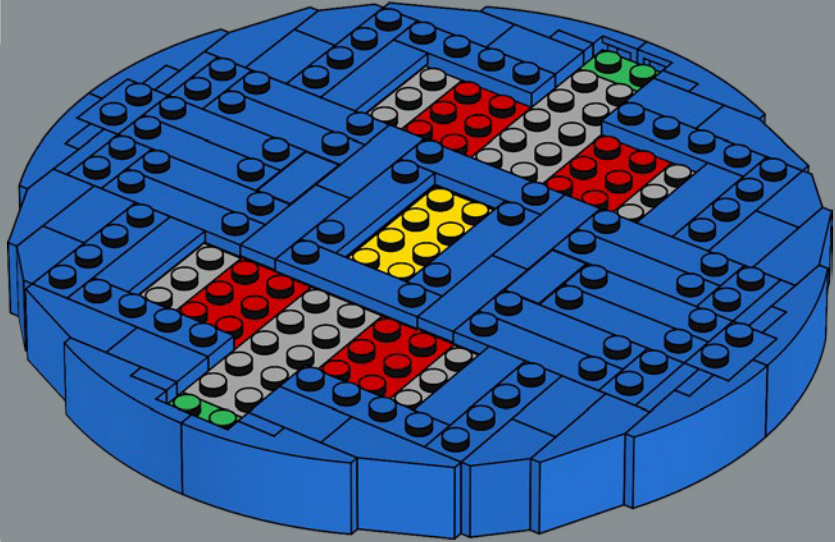

69

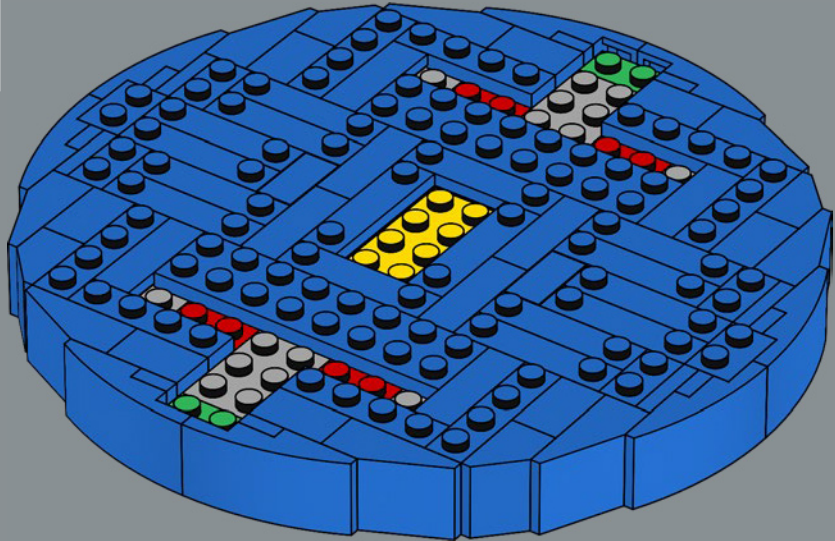

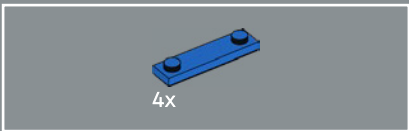

70

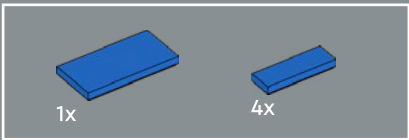
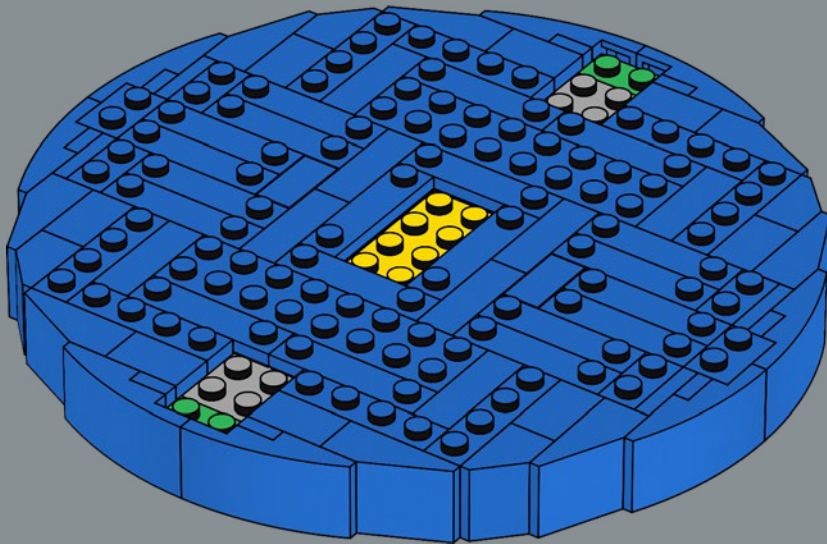

71

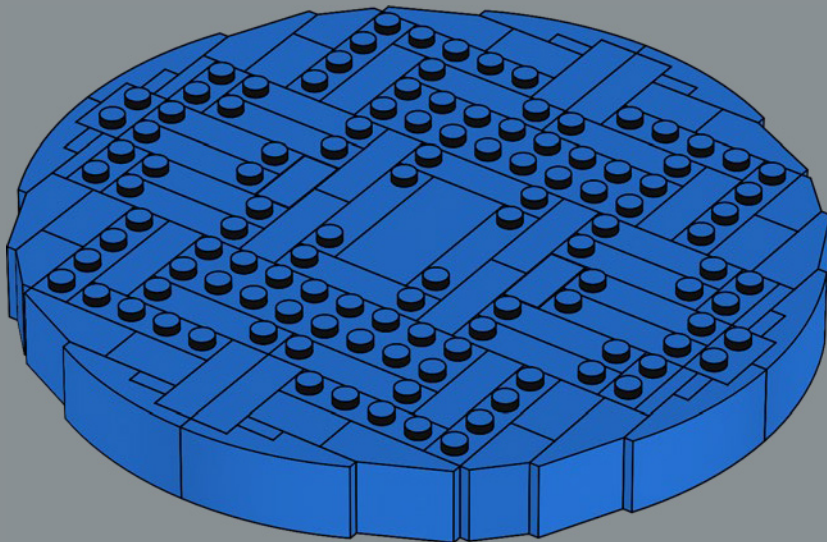

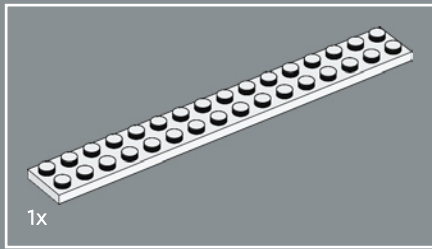

72

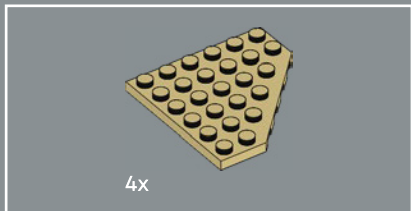
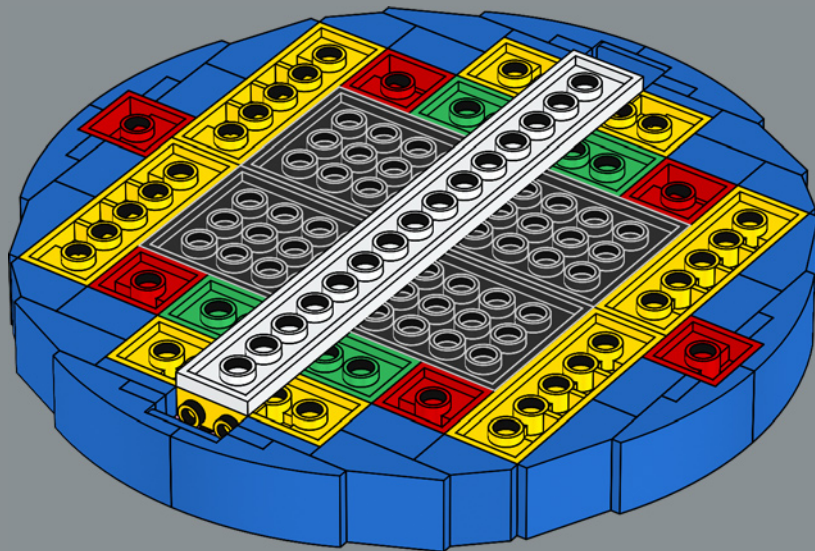

73

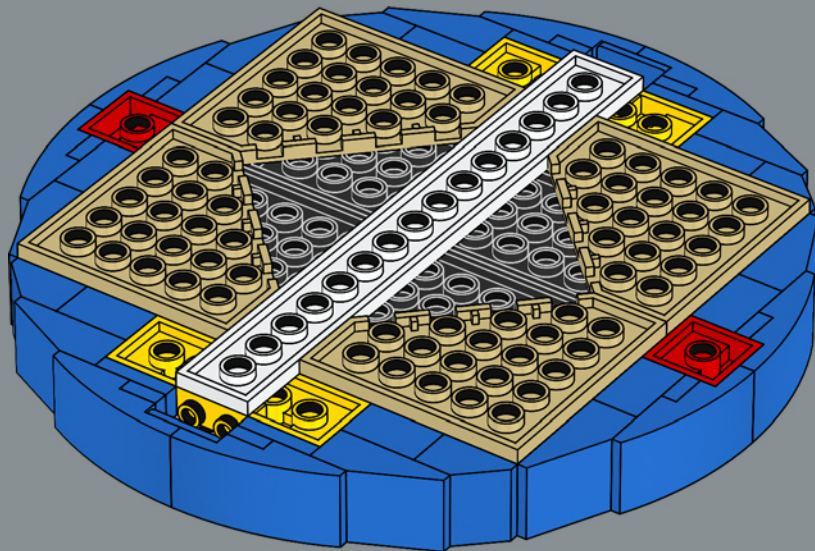

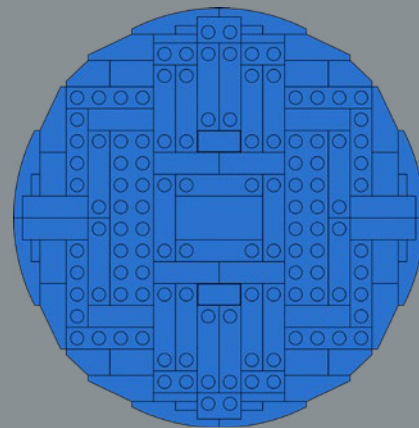
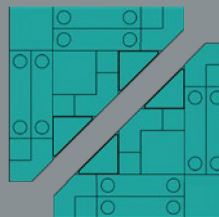
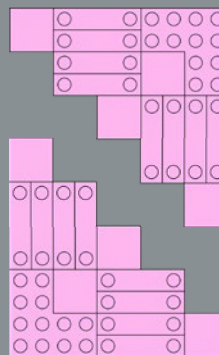
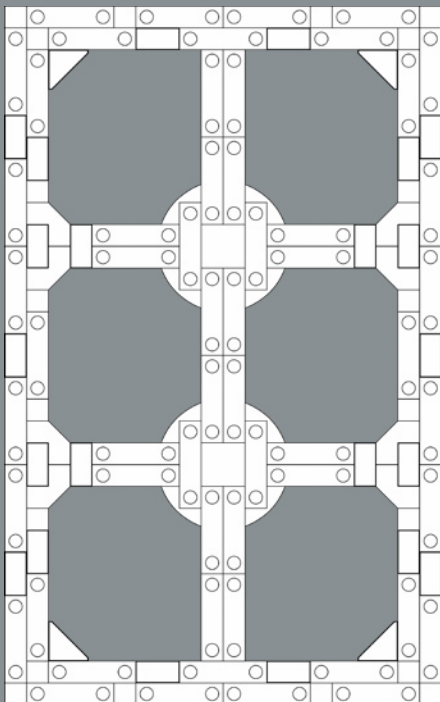
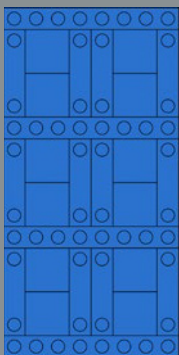
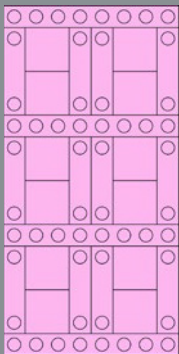
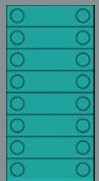
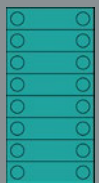

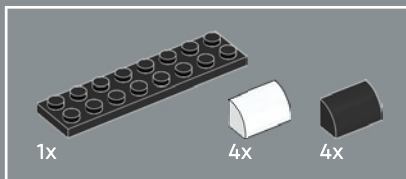
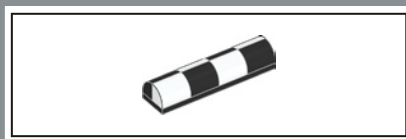

74

1

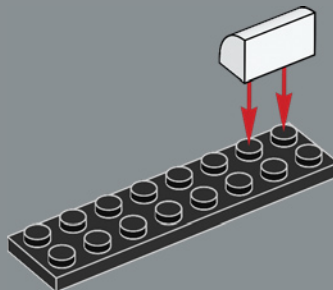

2

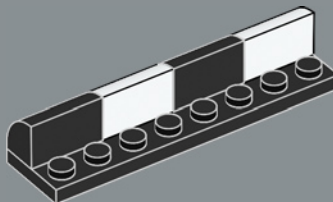

3

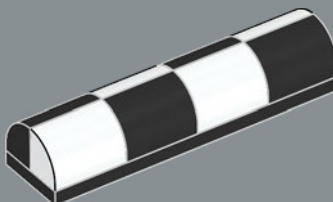

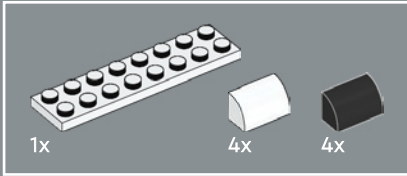
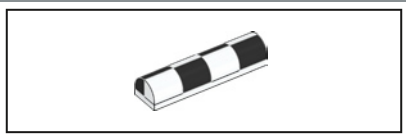

75

1

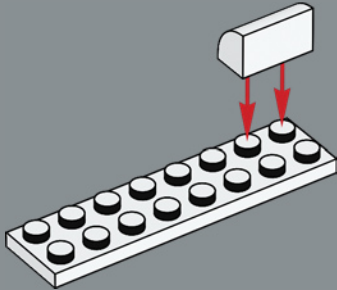

2

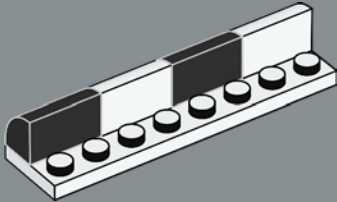

3

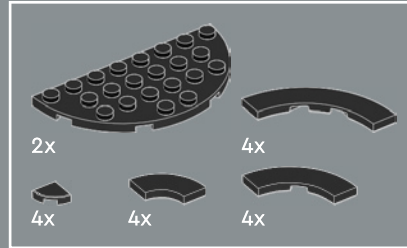
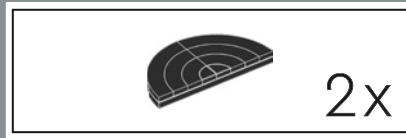
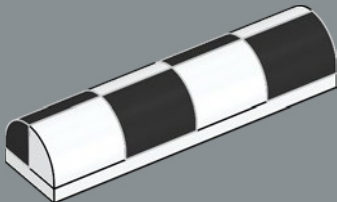

76

1

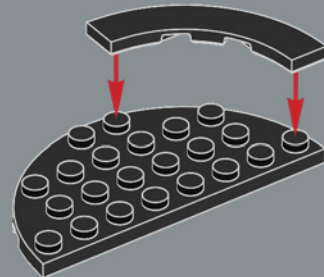

2

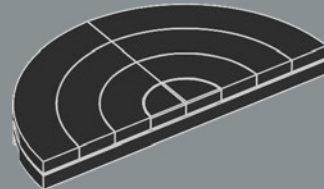

2x

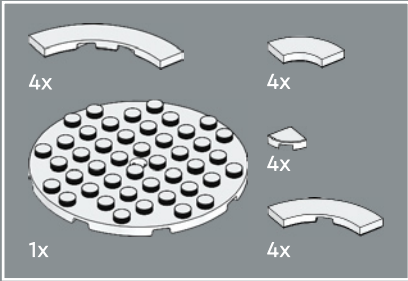
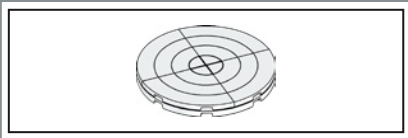

77

1

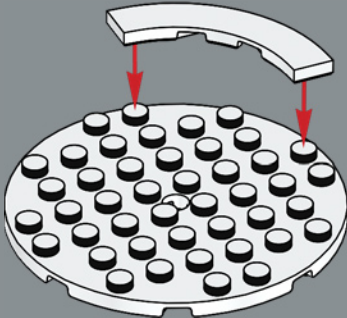

2

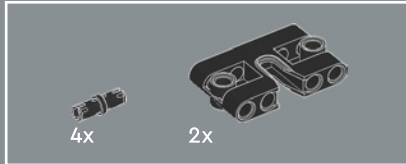
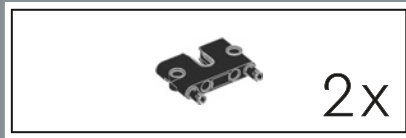
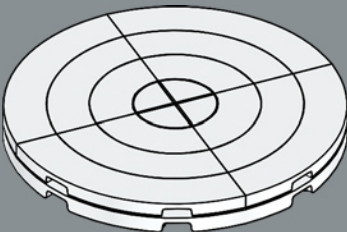

78

1

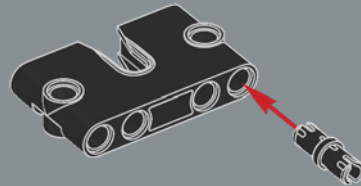

2

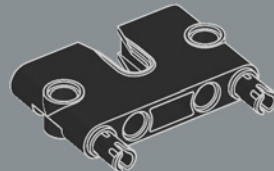

2x

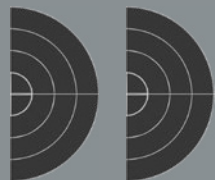
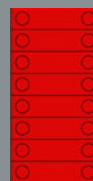
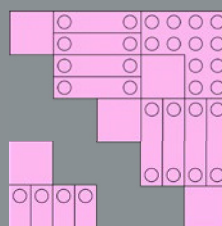
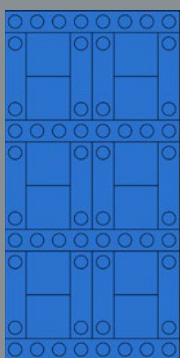
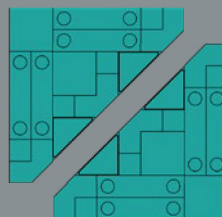
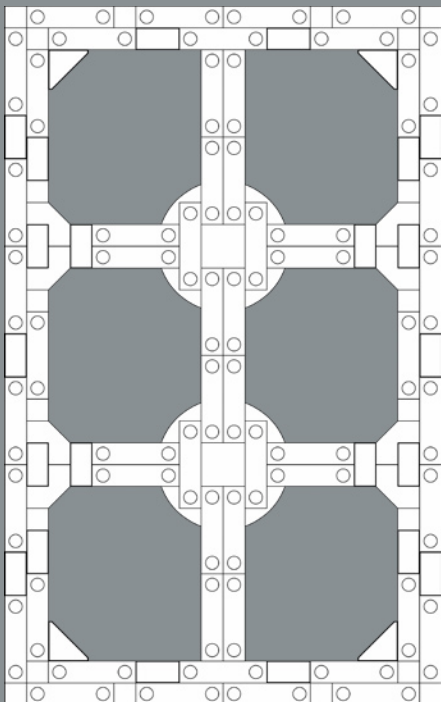
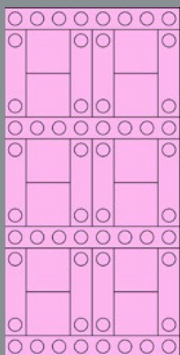
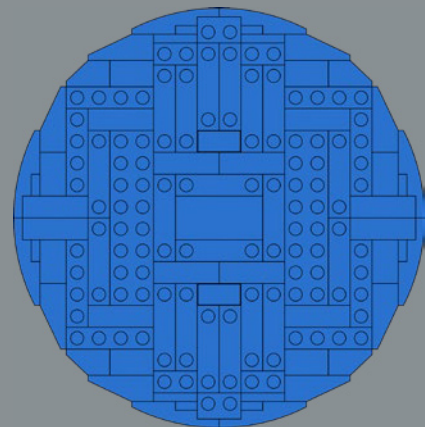
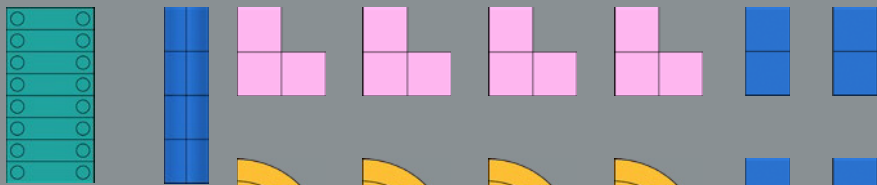

A

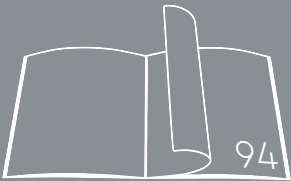

B

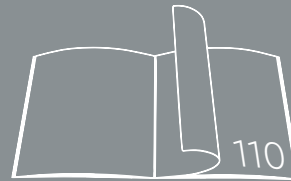

C

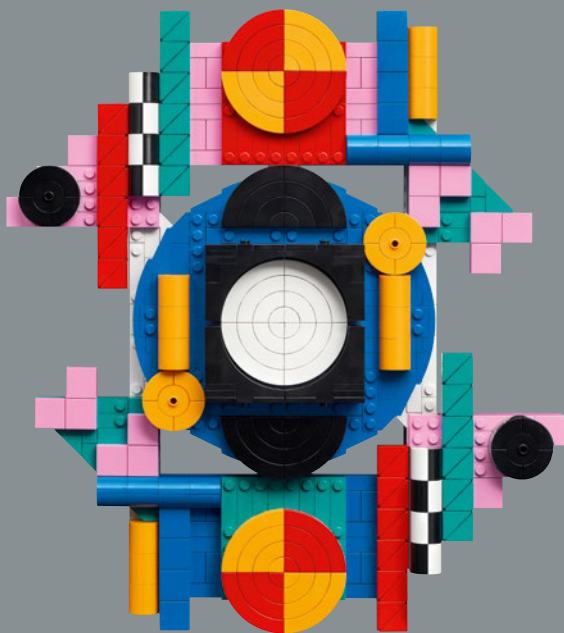

D

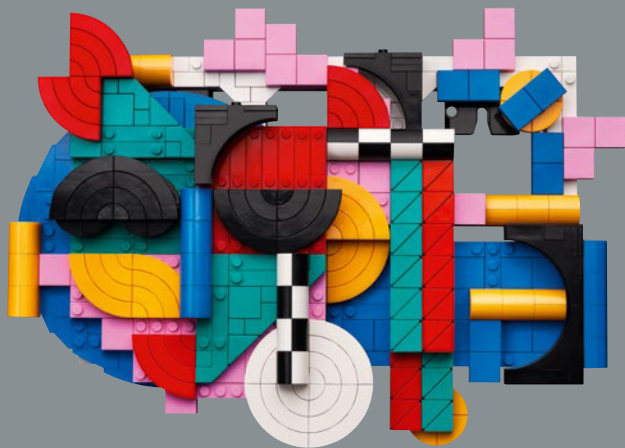





1

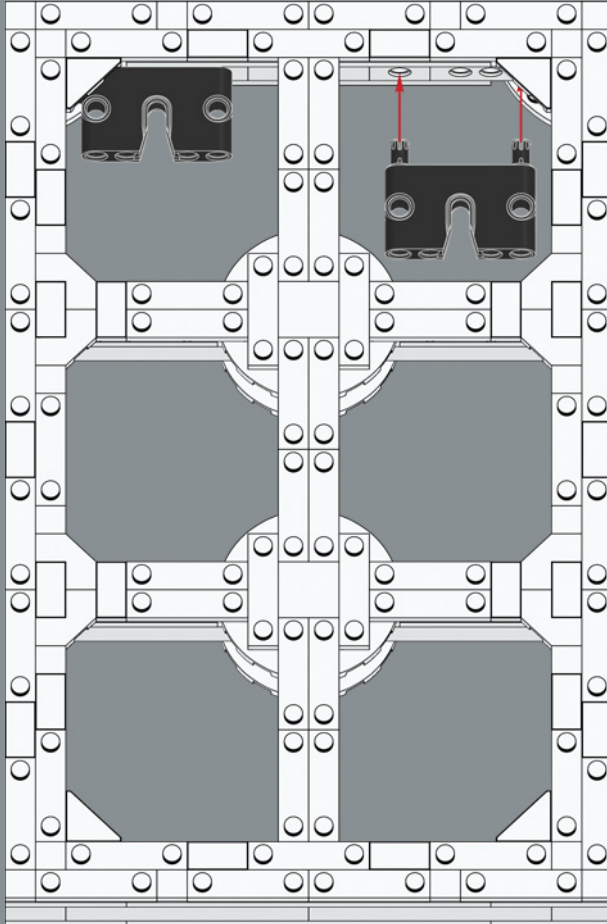

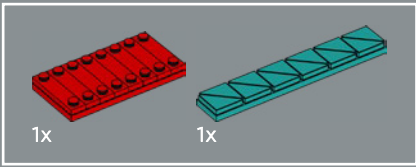

2

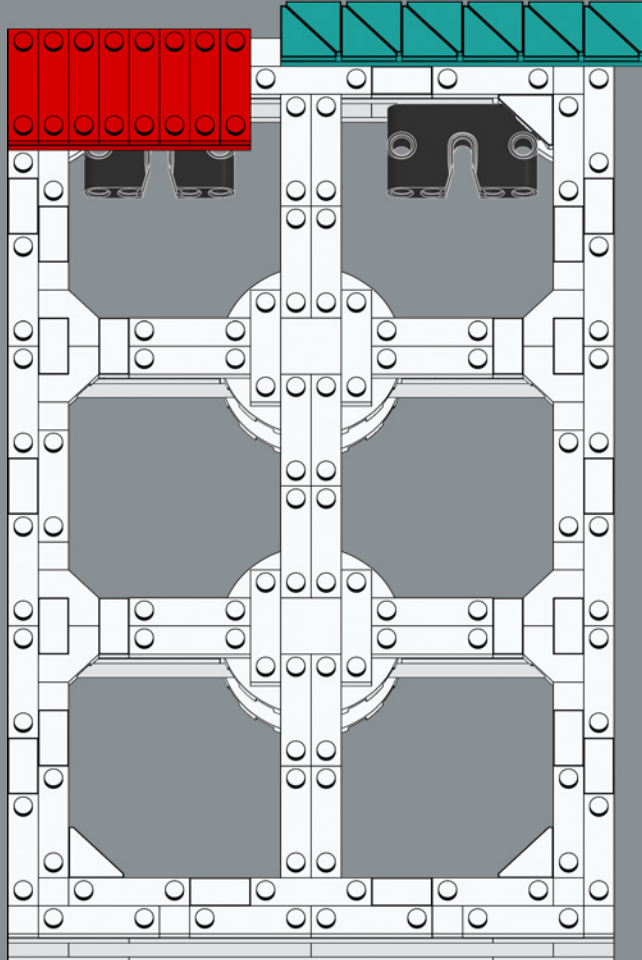

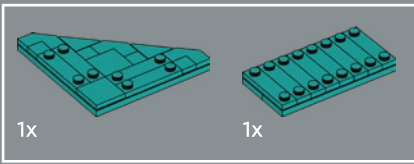

3

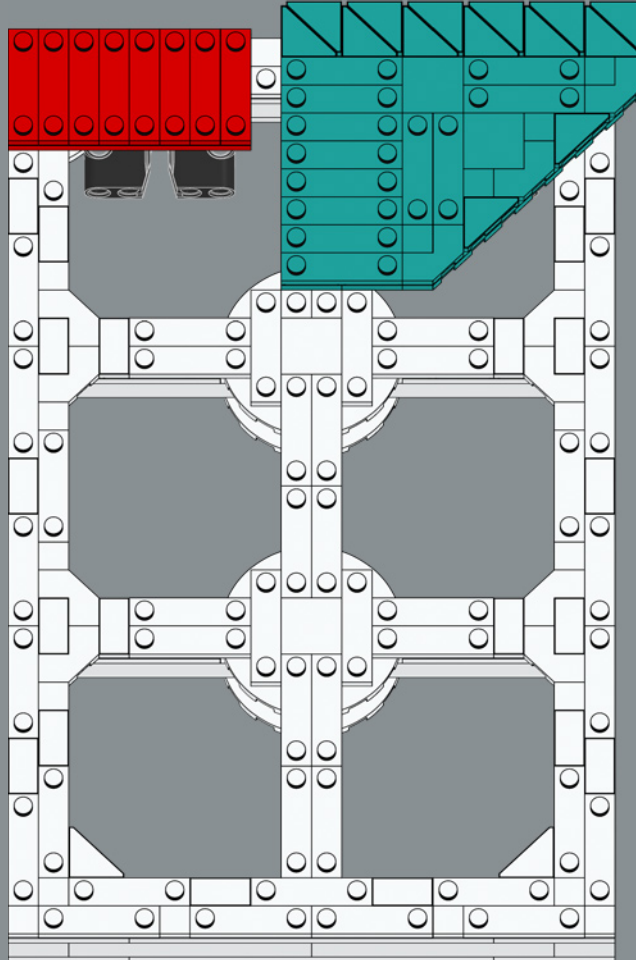

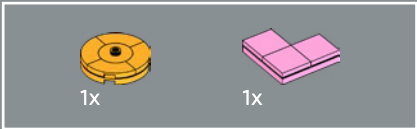

4

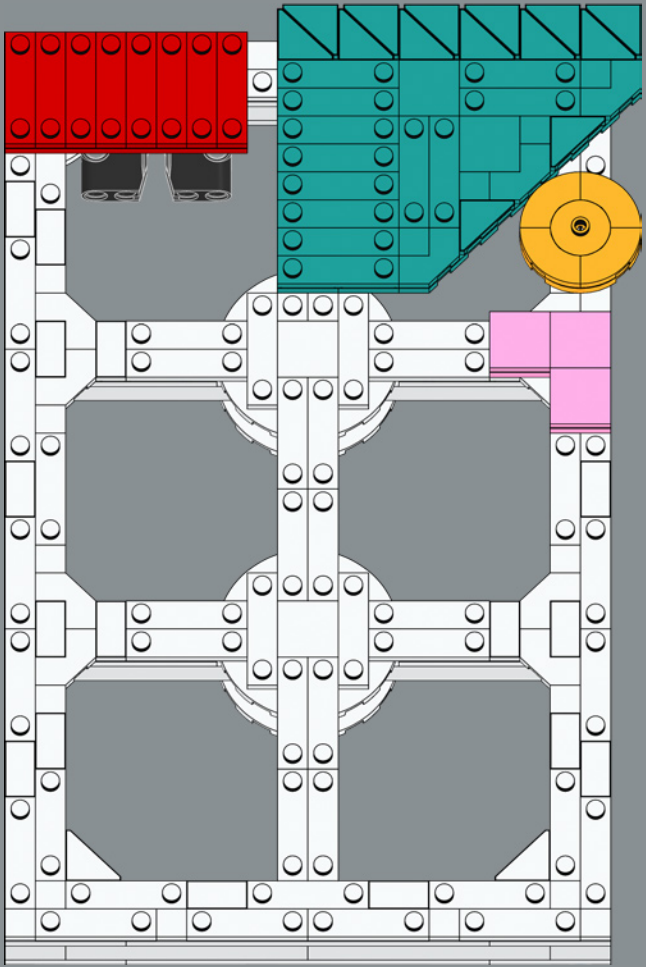

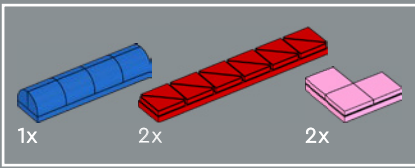

5

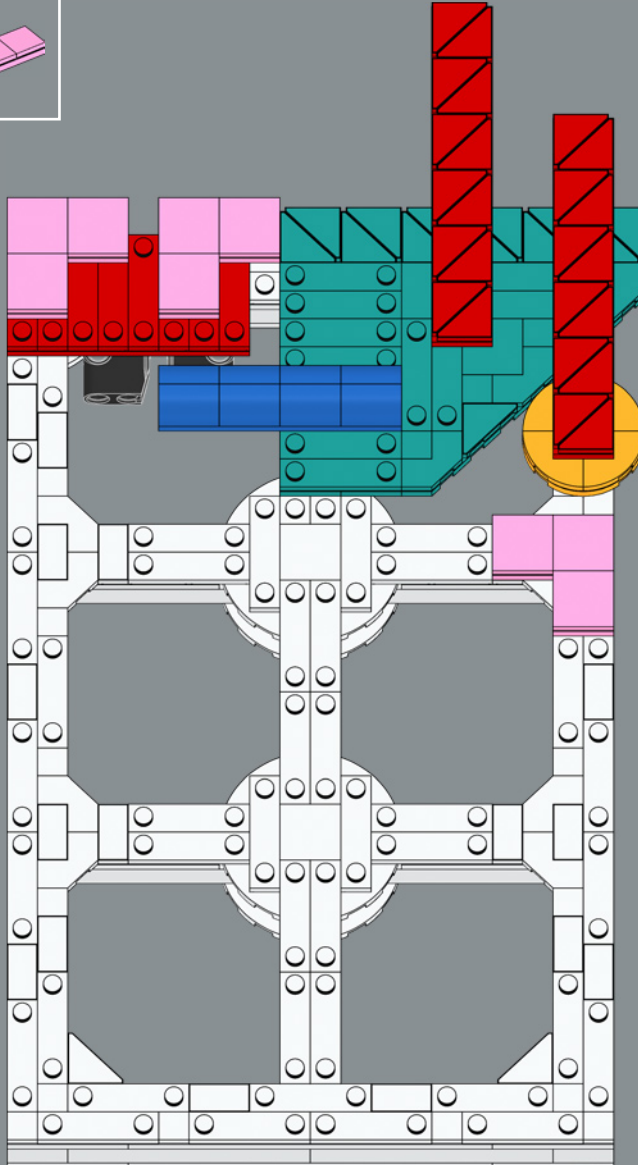

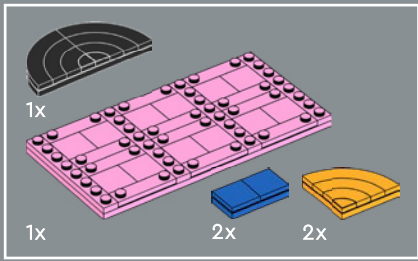

6

1

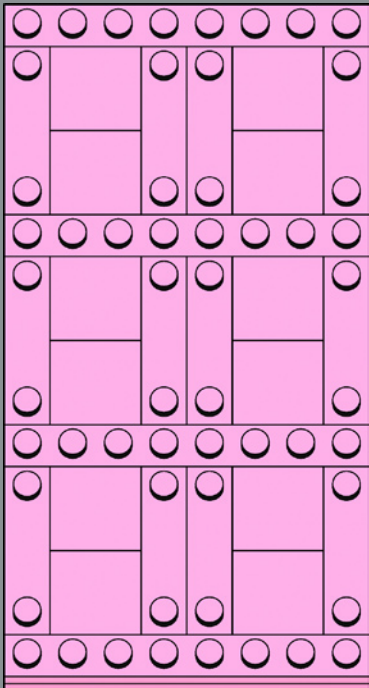

2

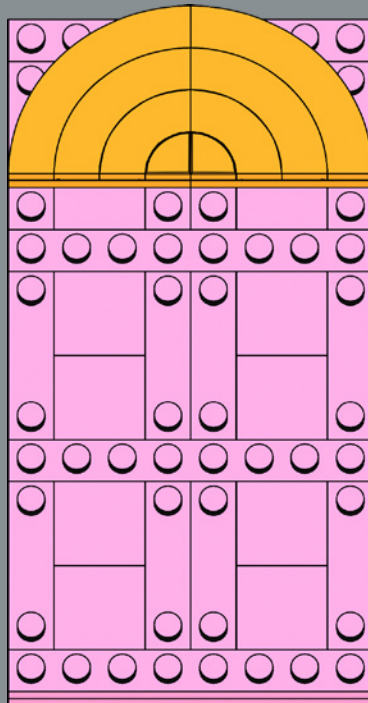

3

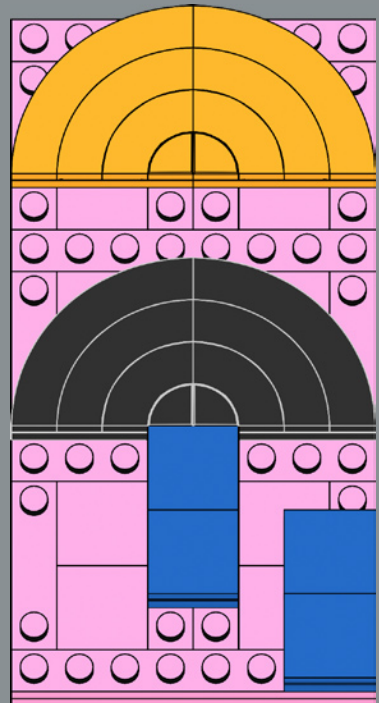

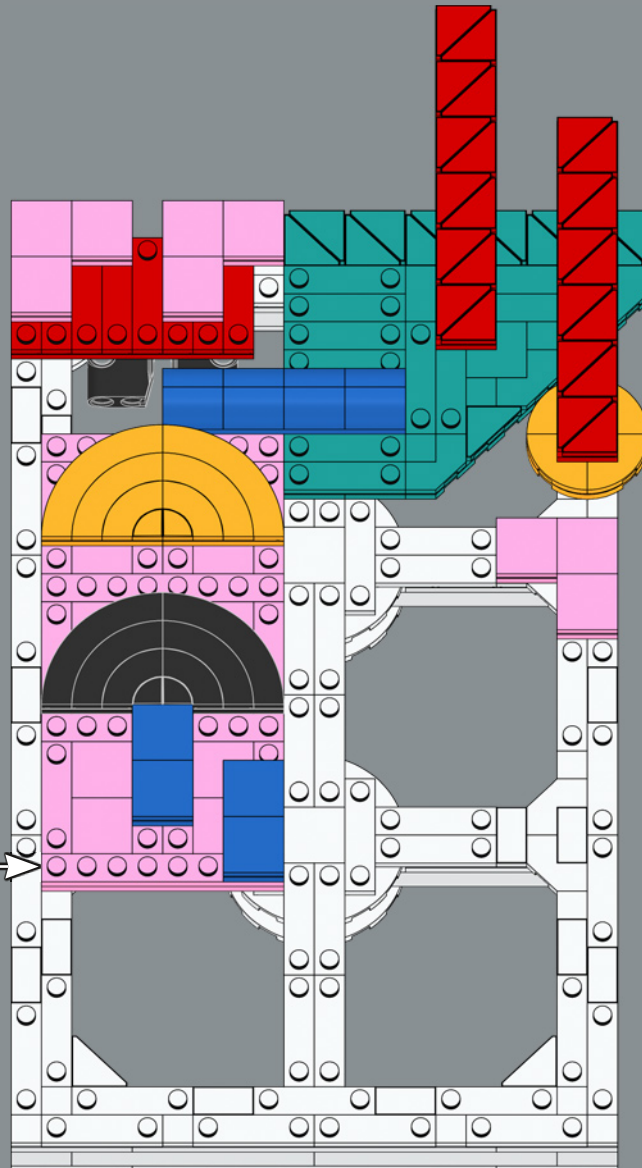

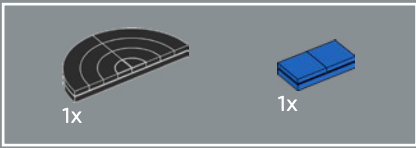

7

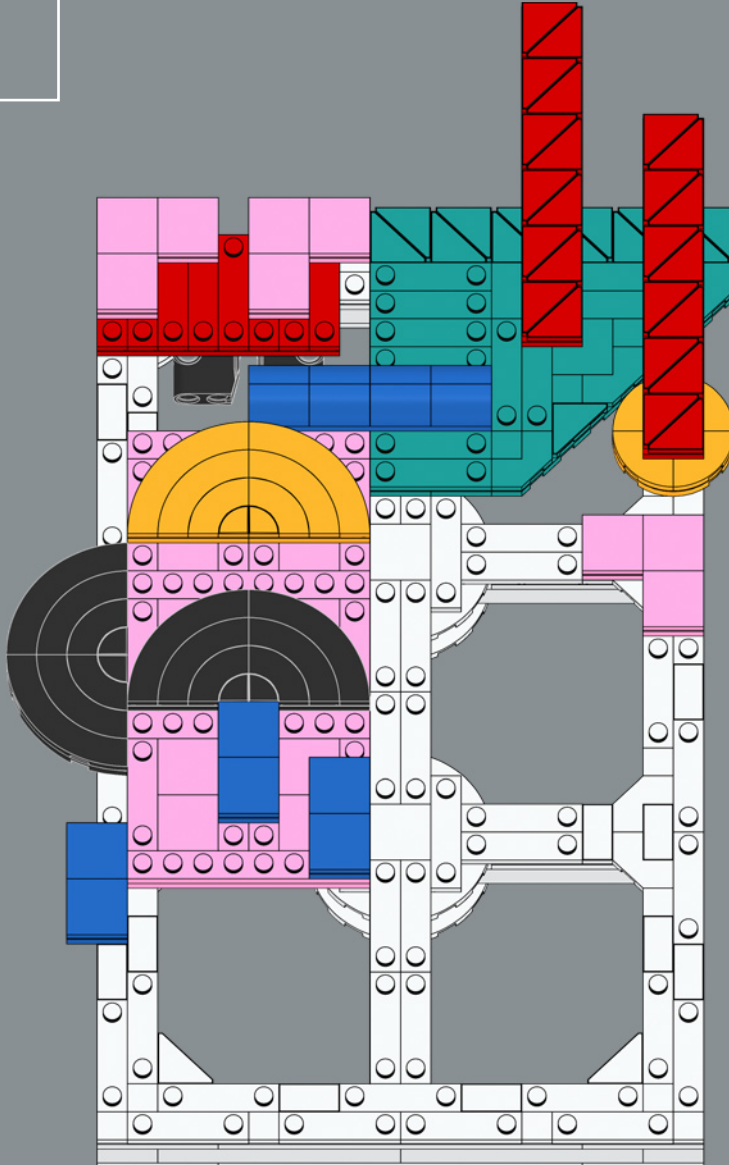

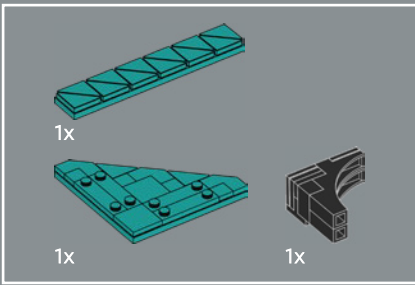

8

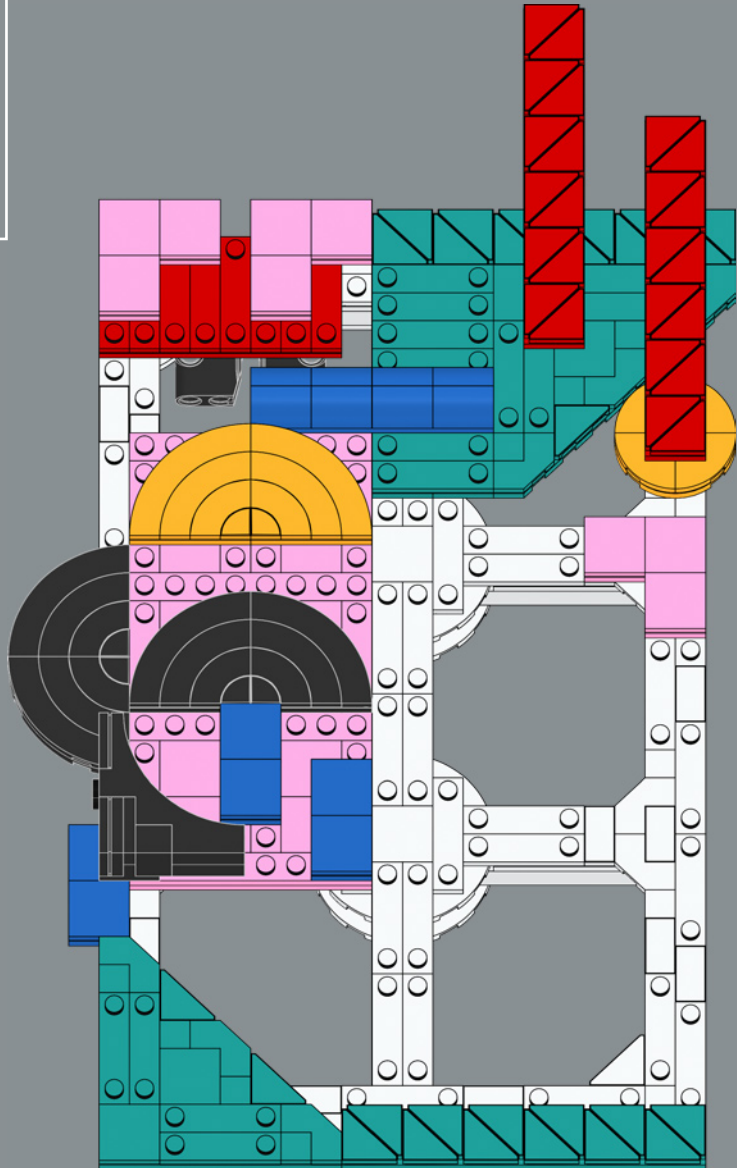

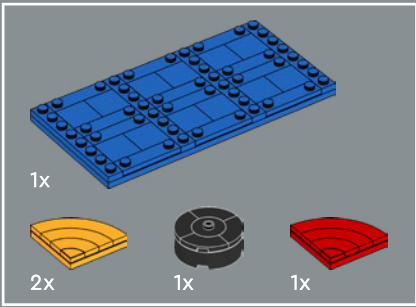

9

1

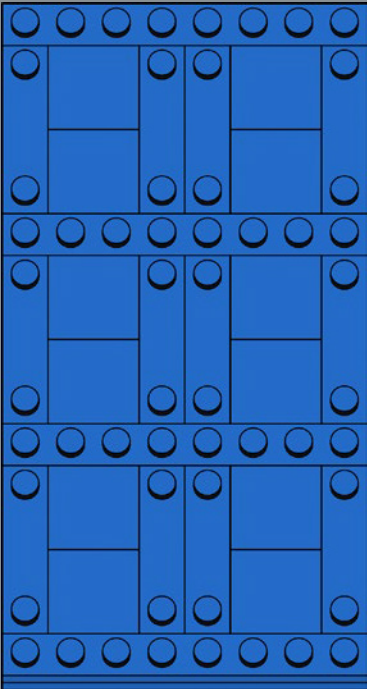

2

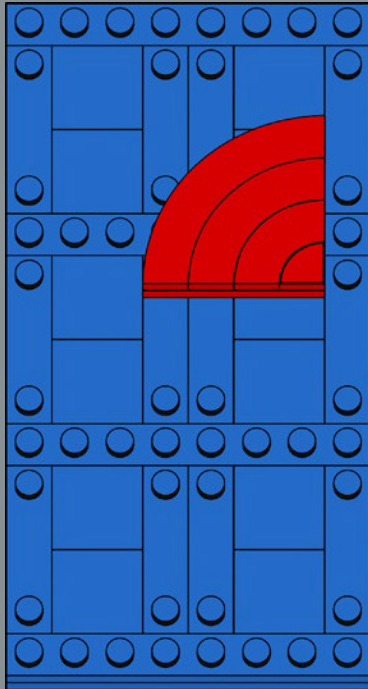

3

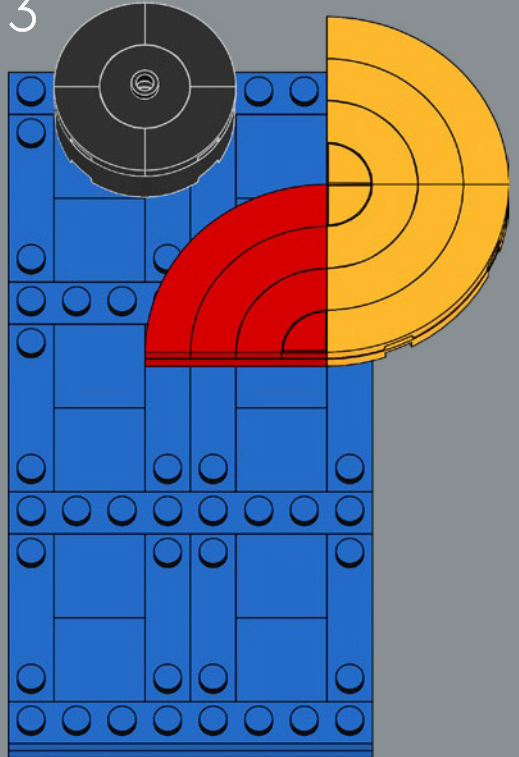

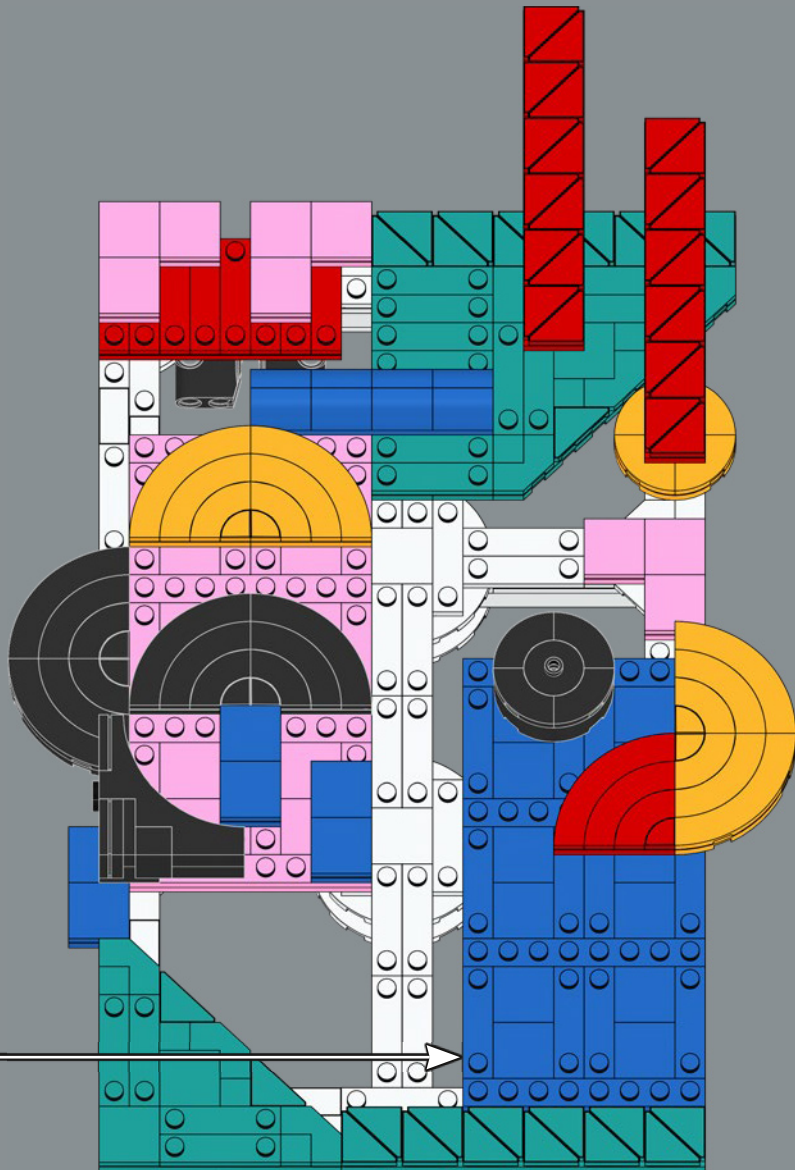

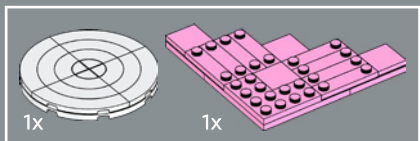

10

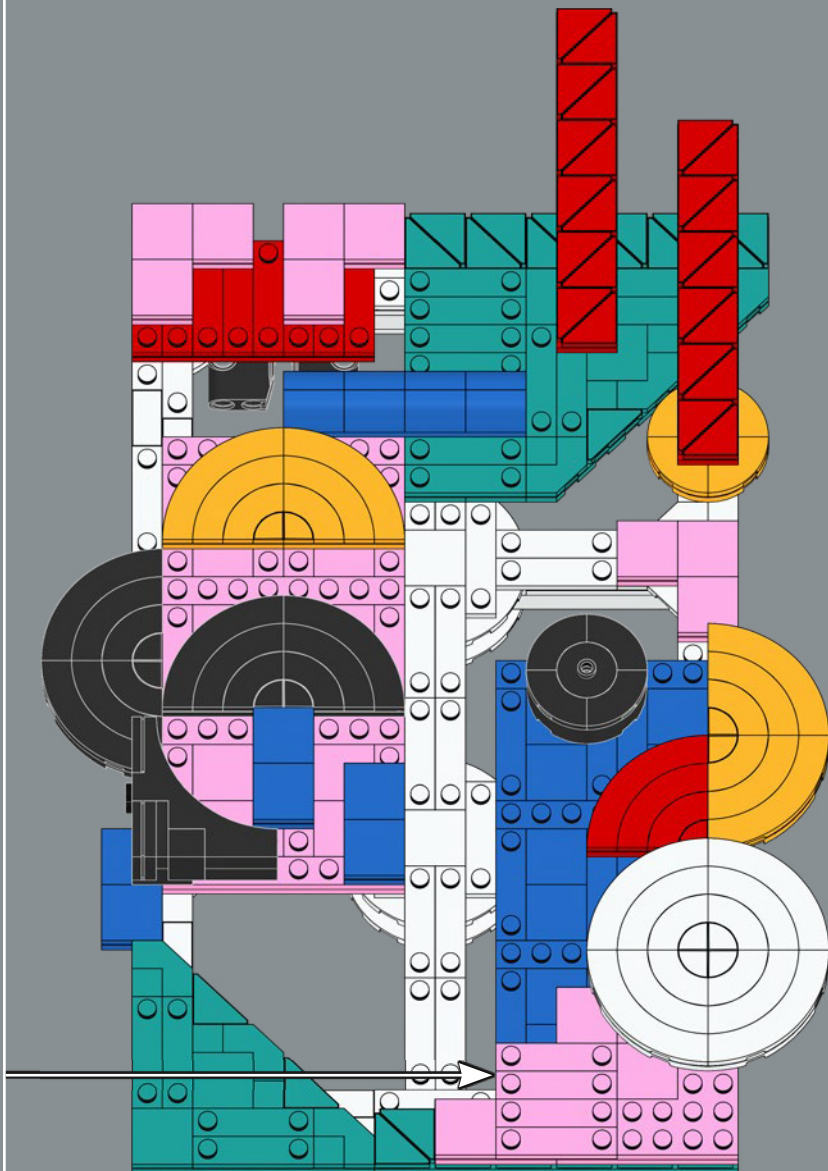
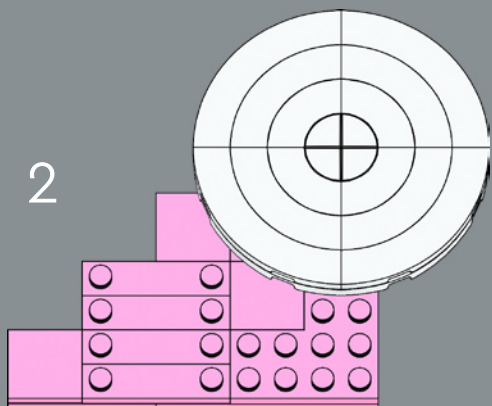
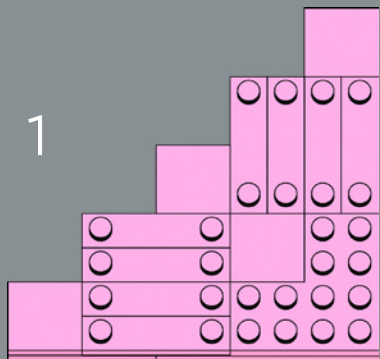

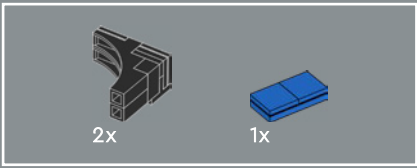

11

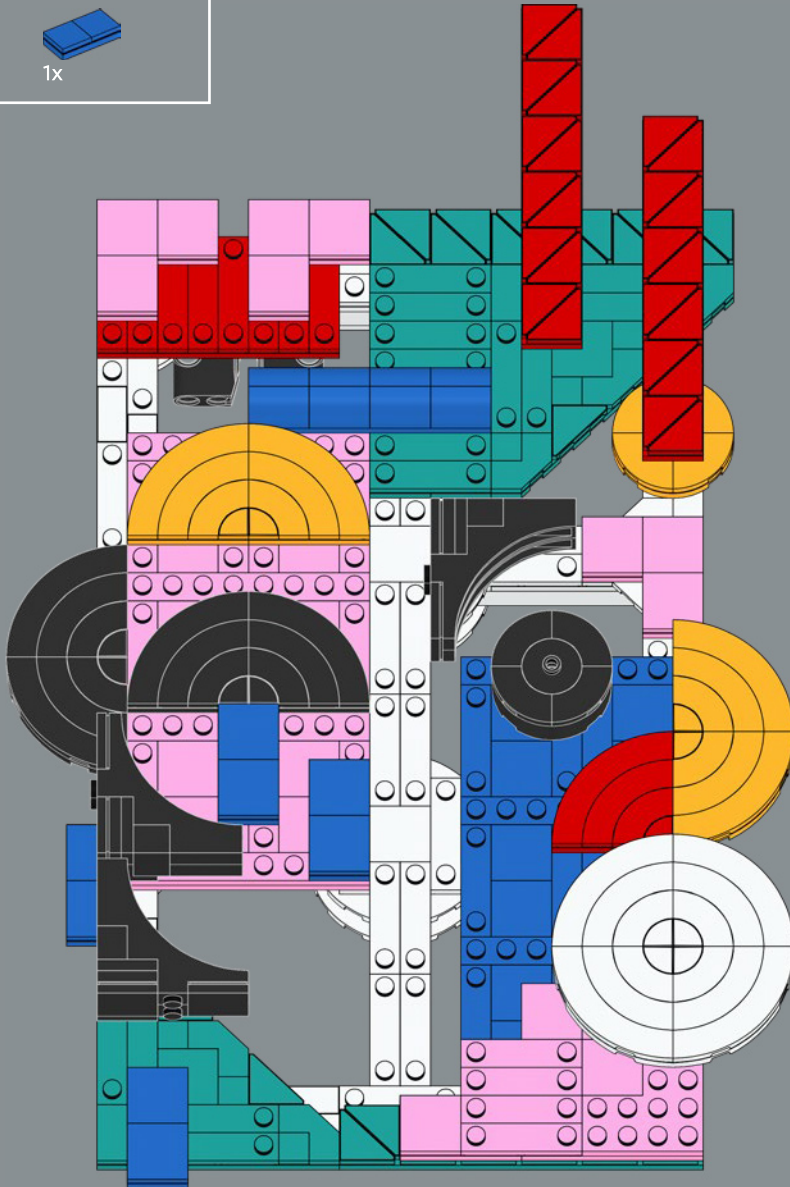

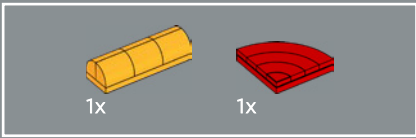

12

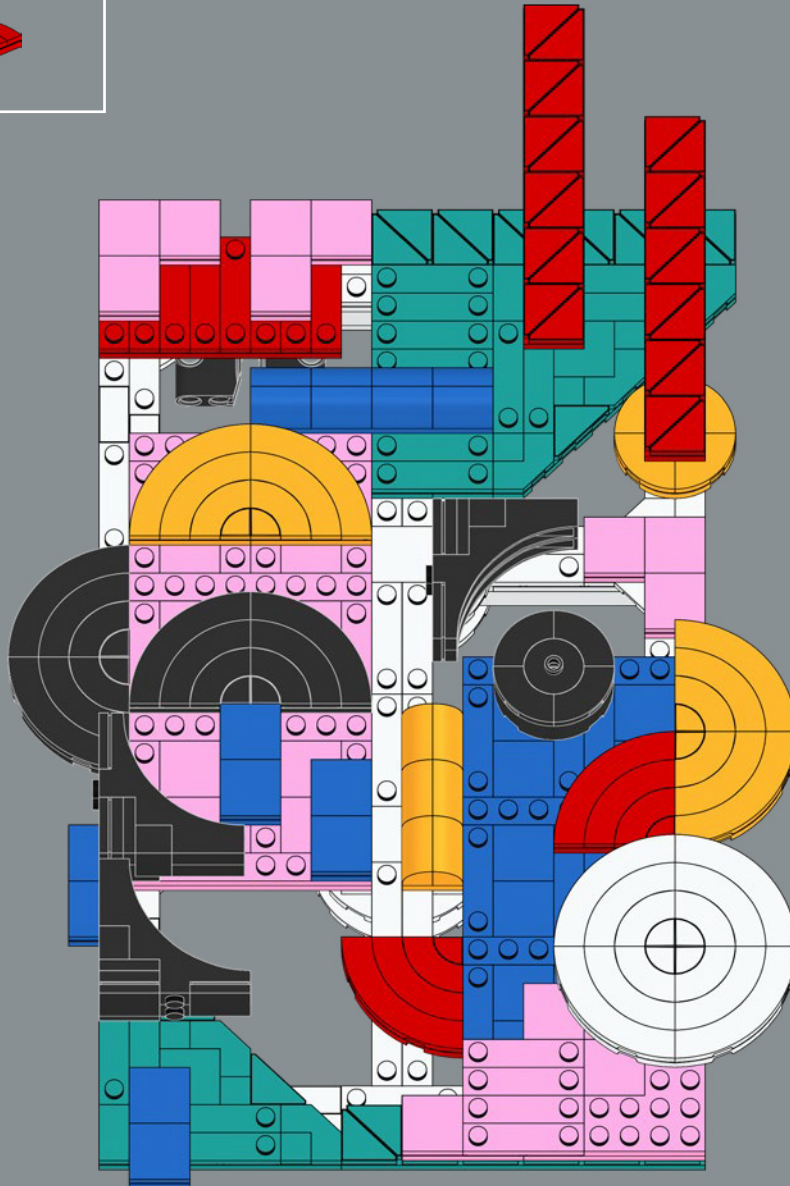

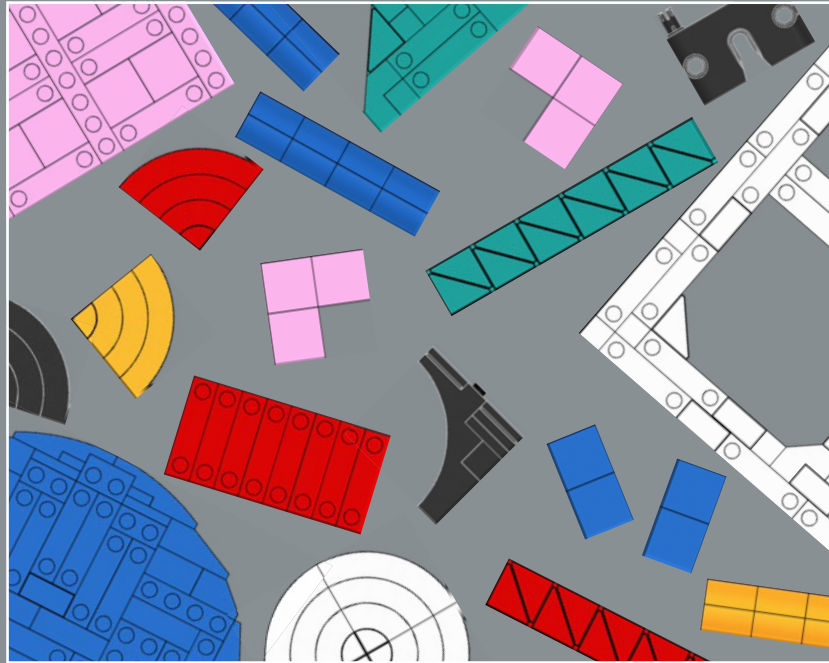

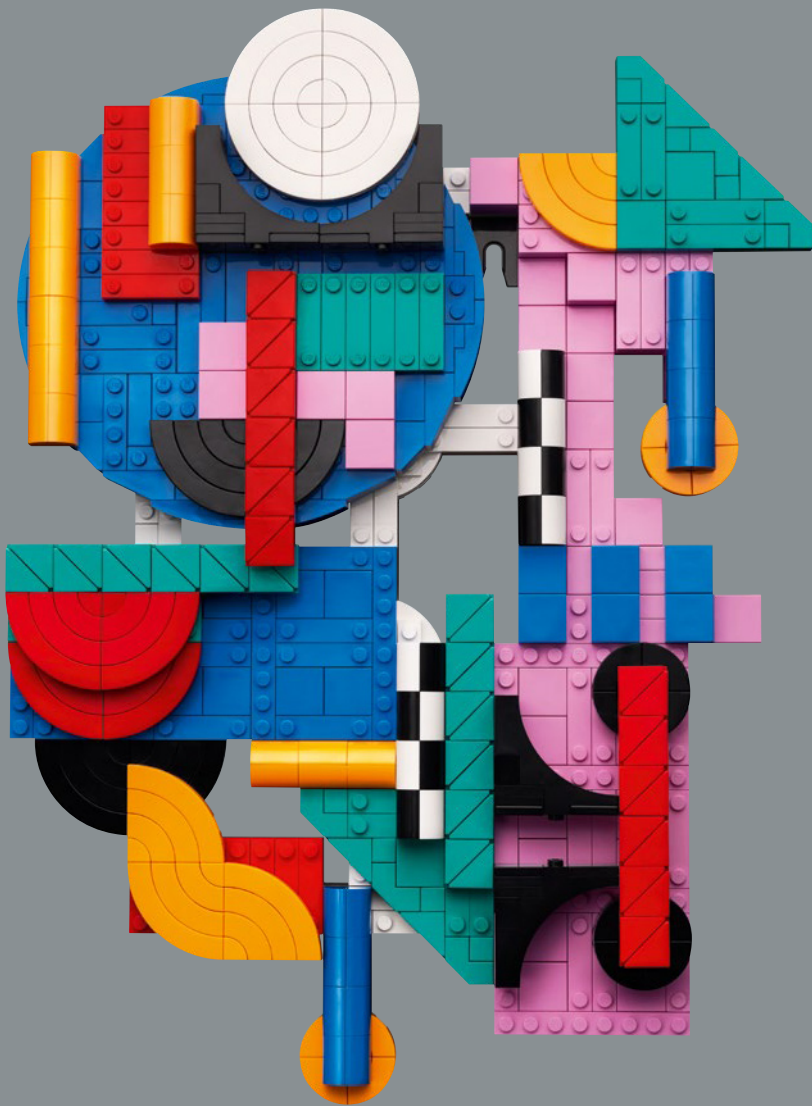



1

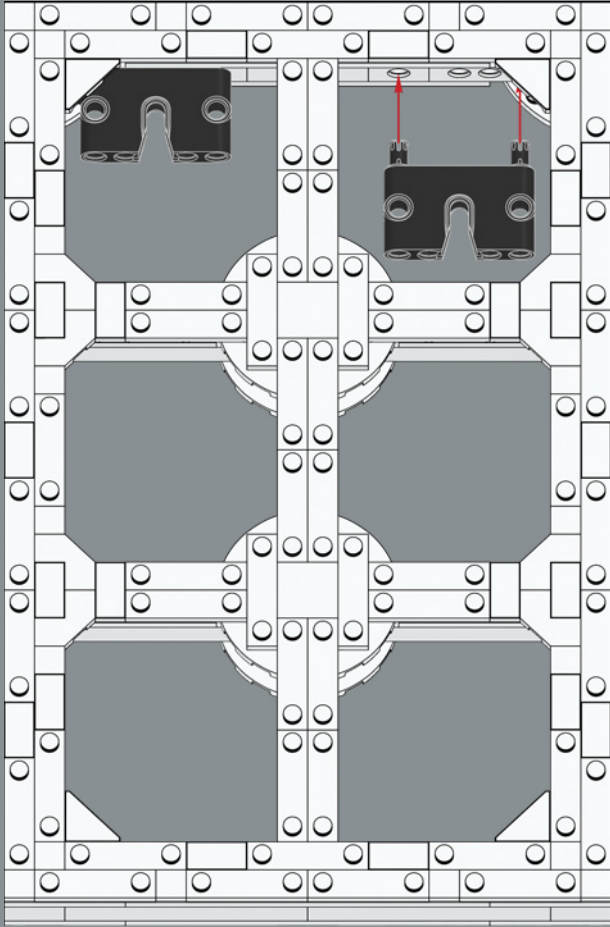

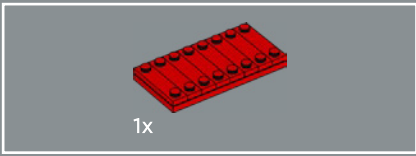

2

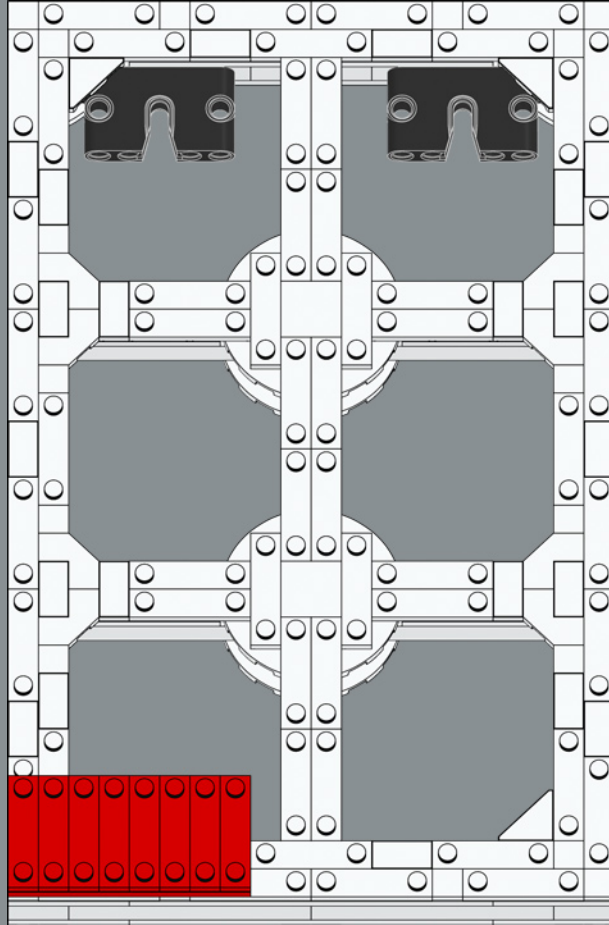

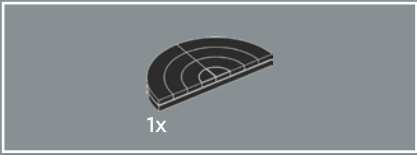

3

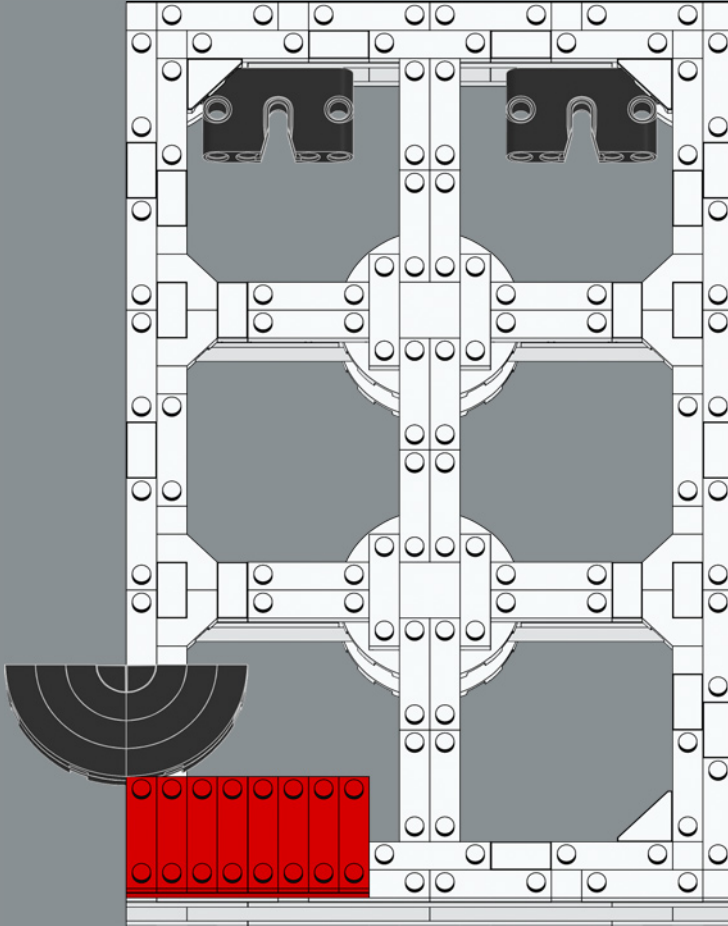

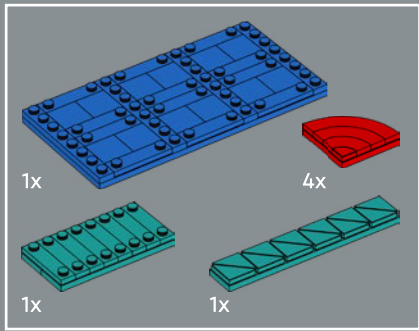

4

1

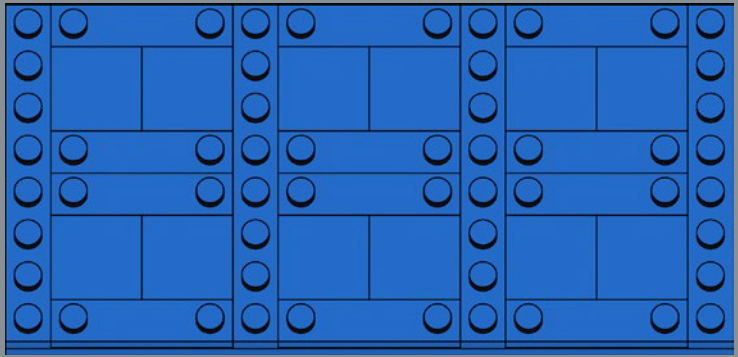

2

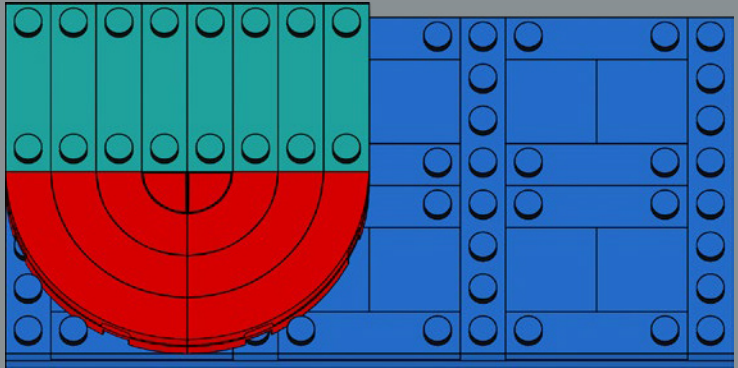

3

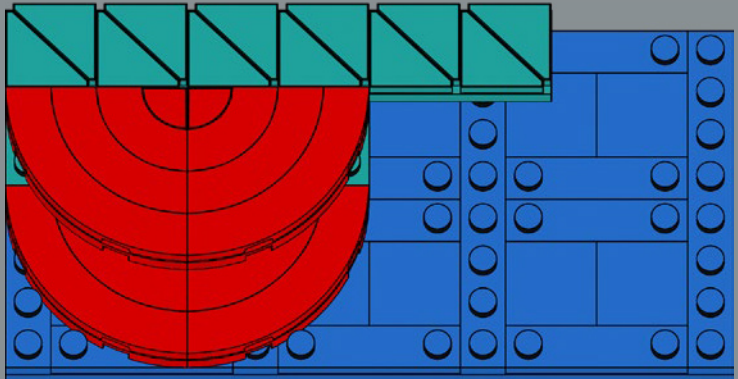

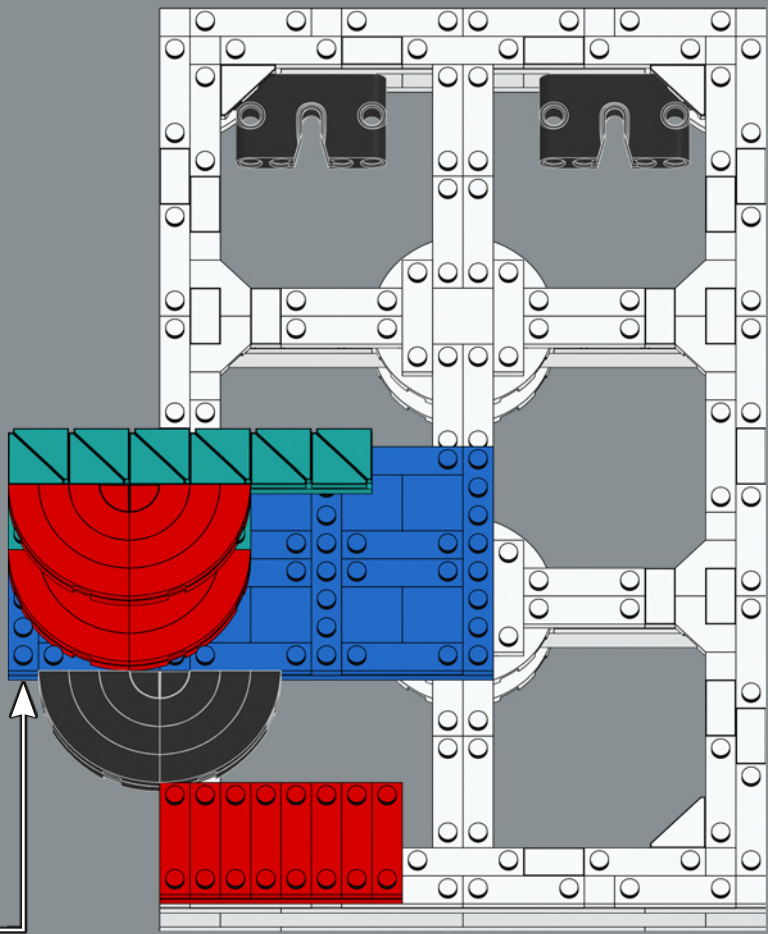

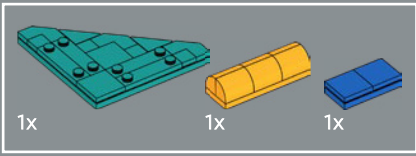

5

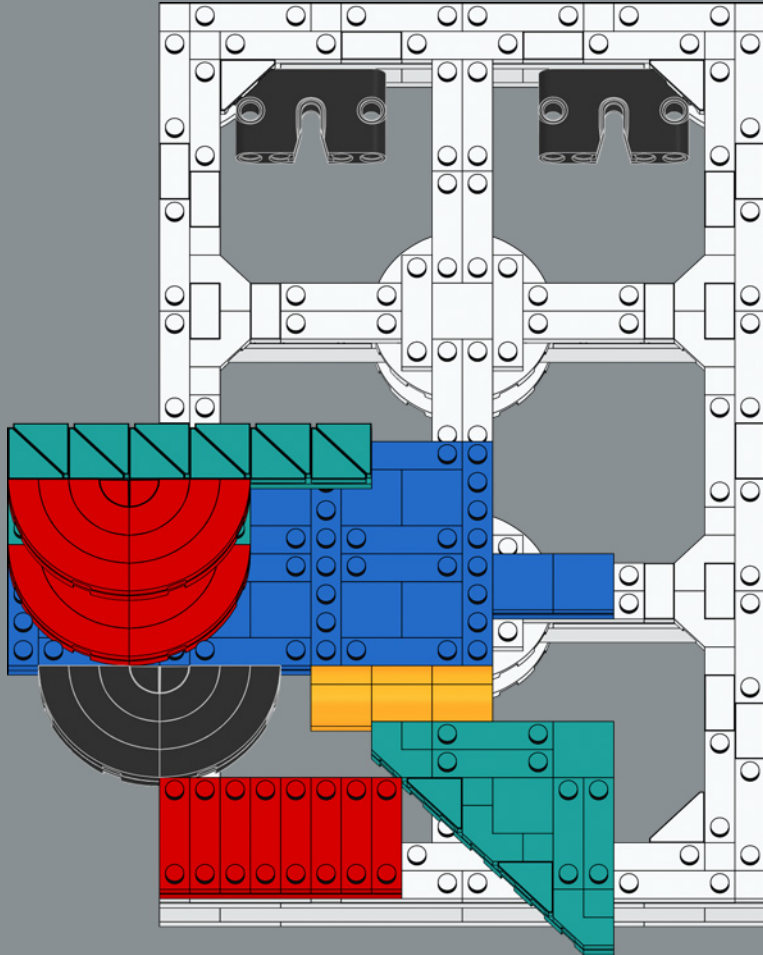

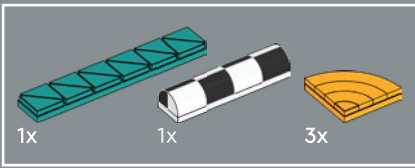

6

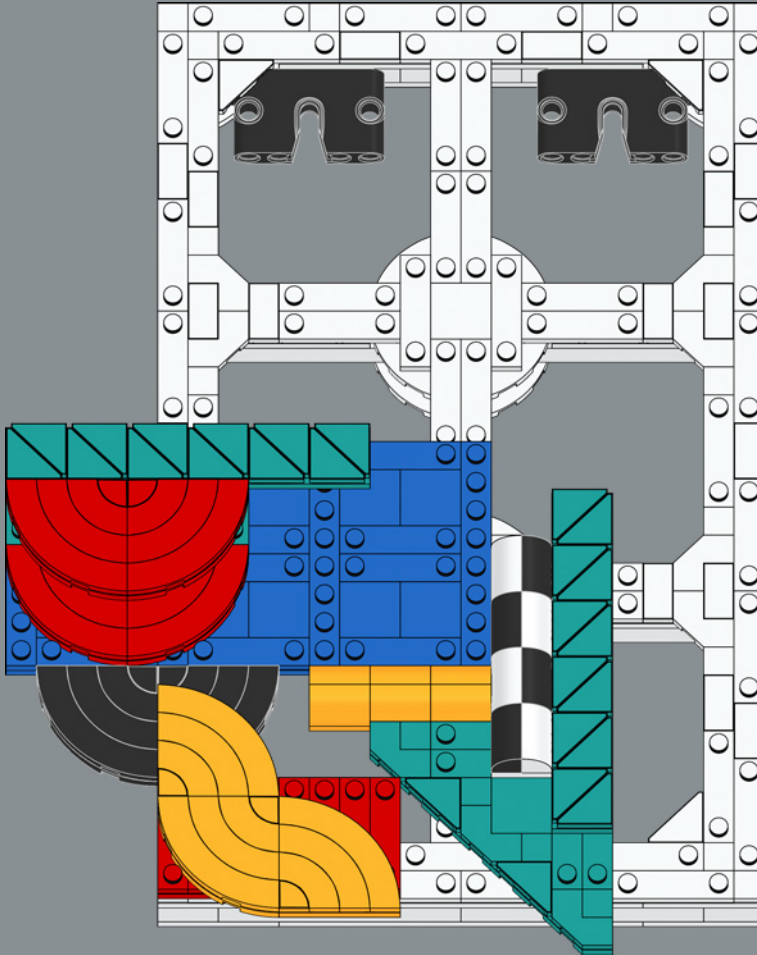

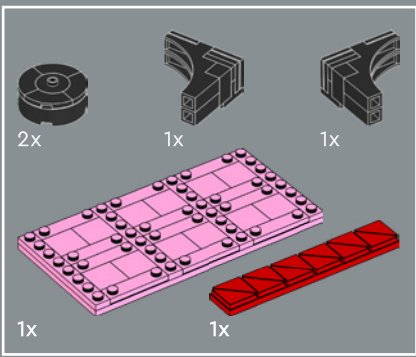

7

1

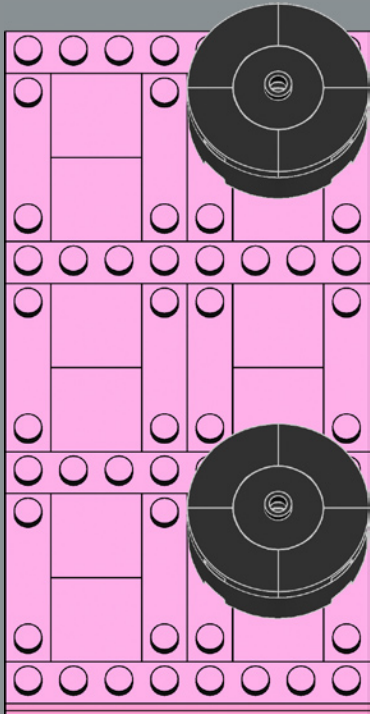

2

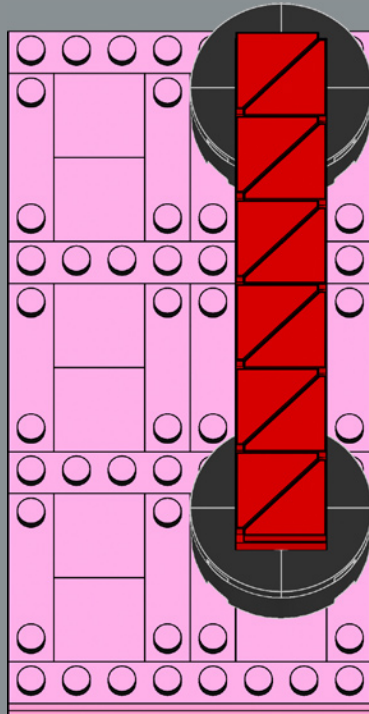

3

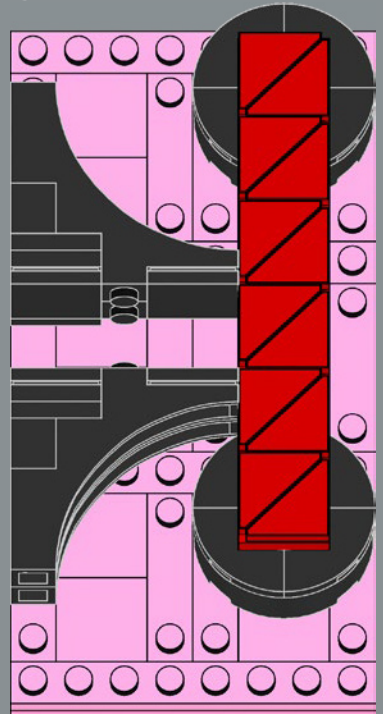

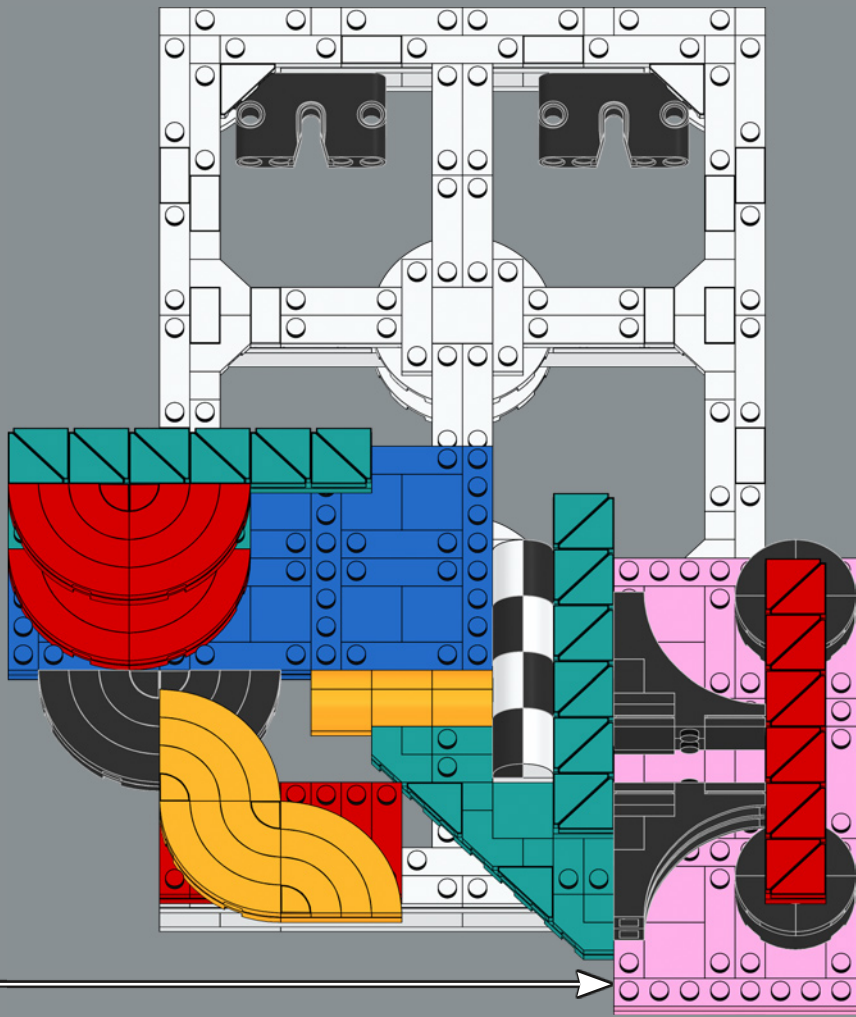

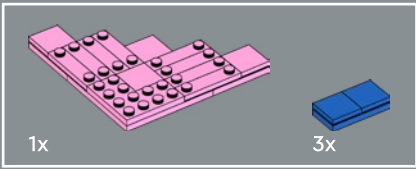

8

1

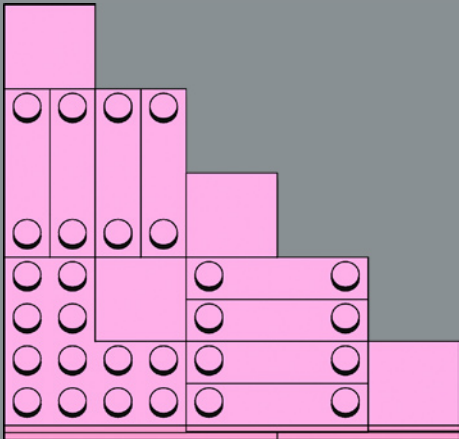

2

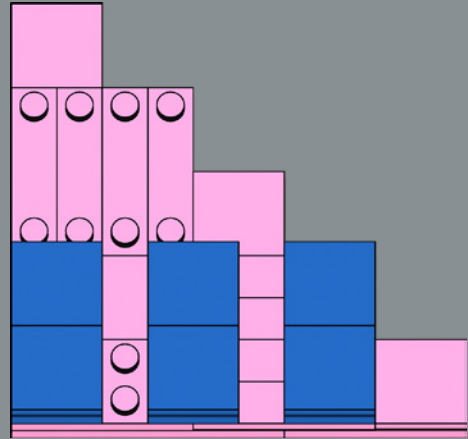

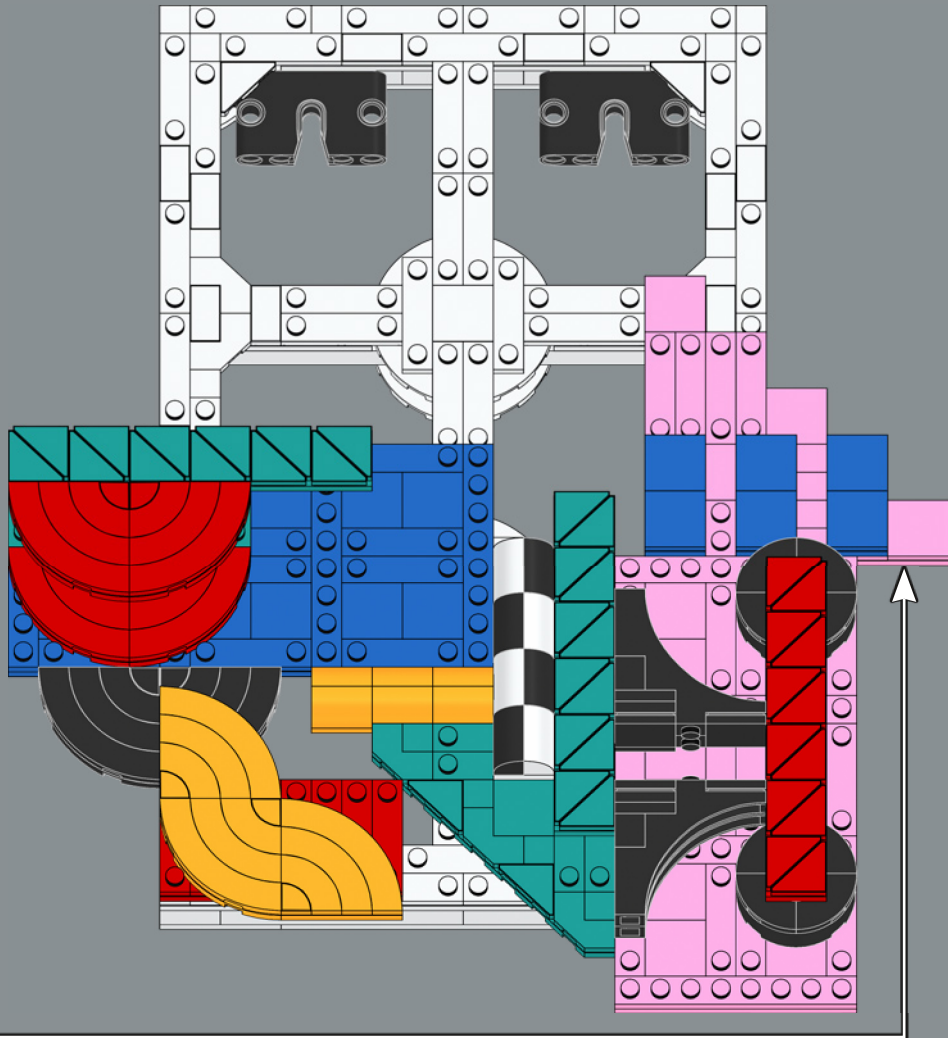

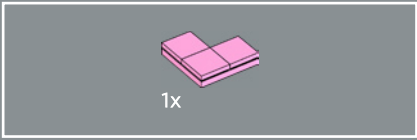

9

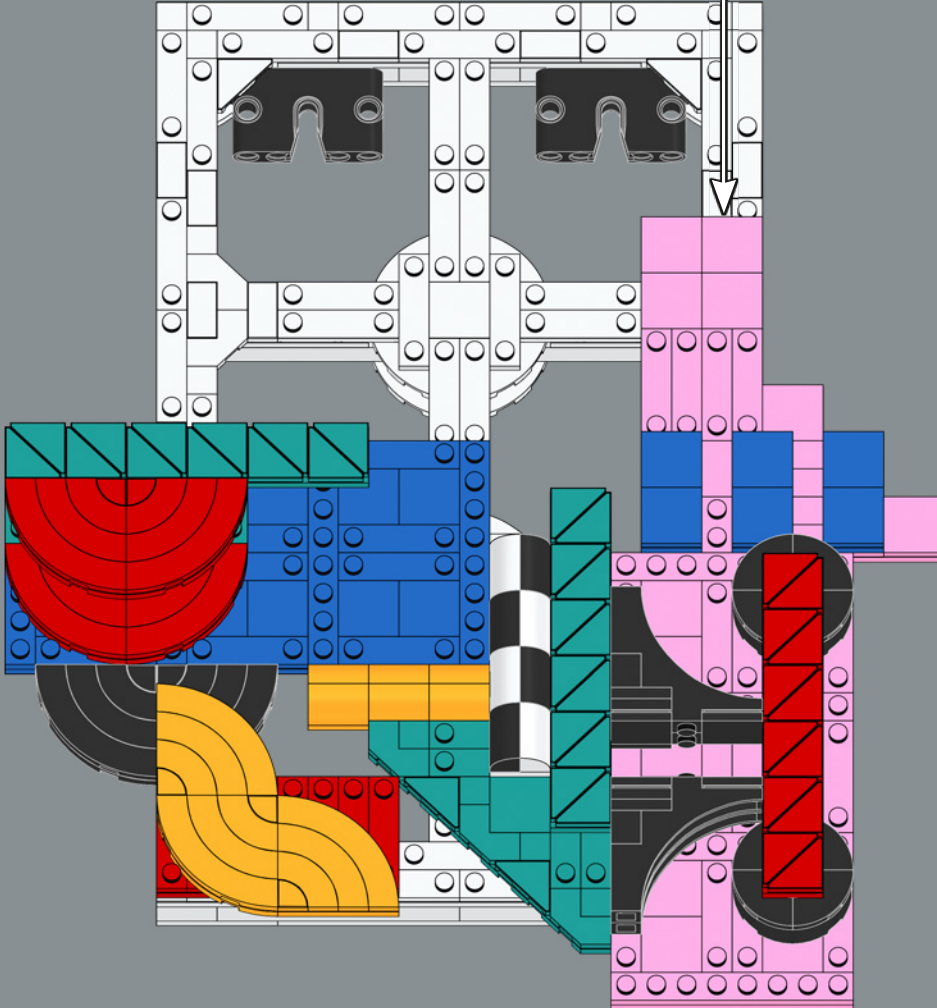
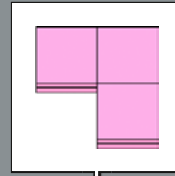

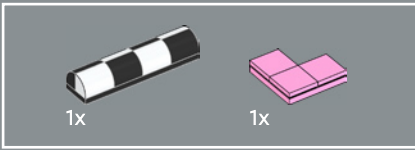

10

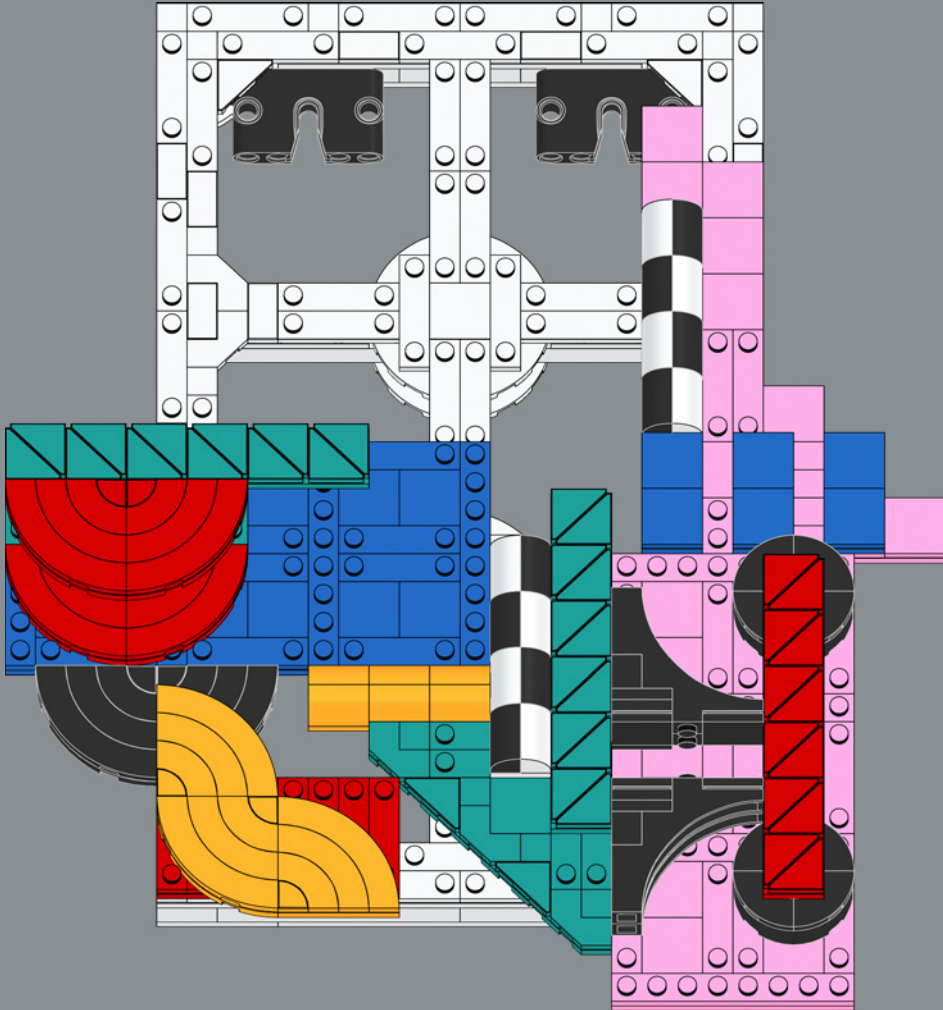

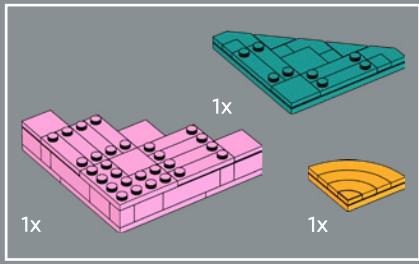

11

1

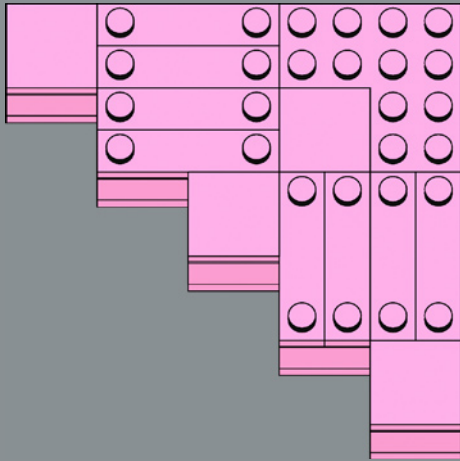

2

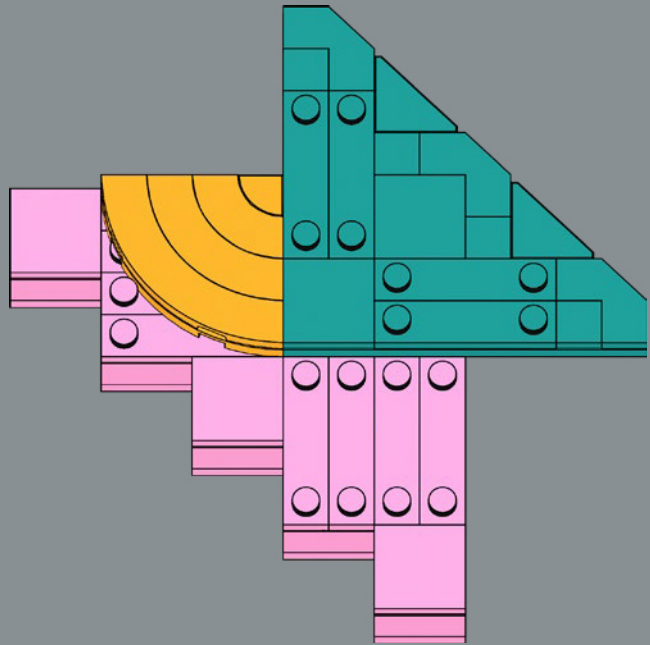

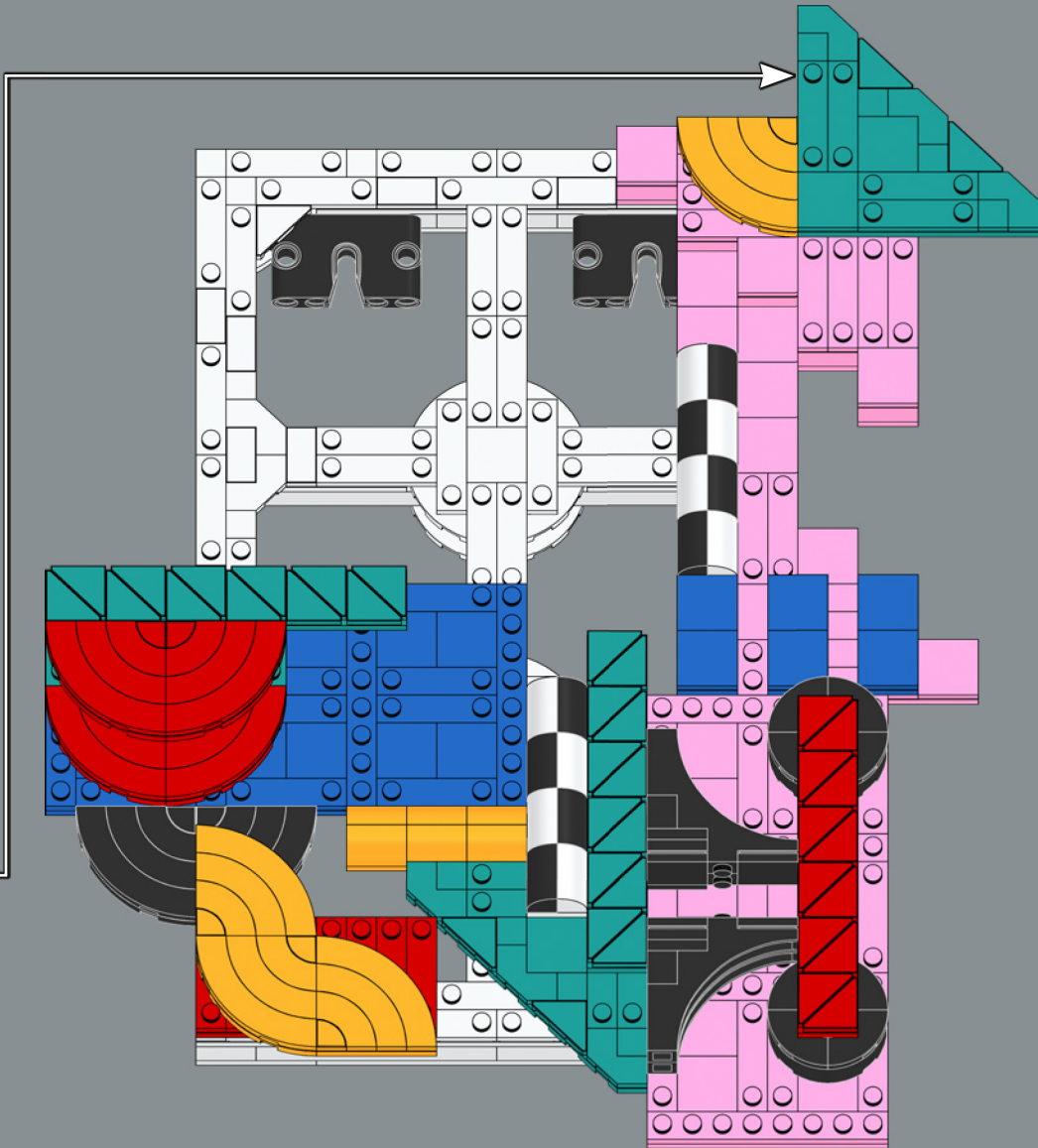

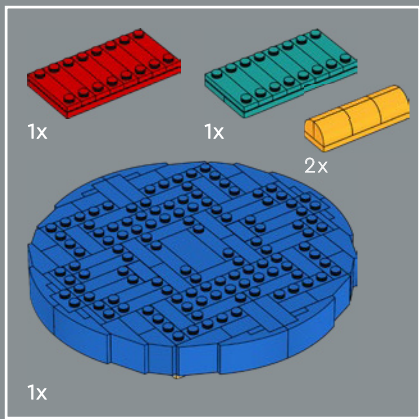

12

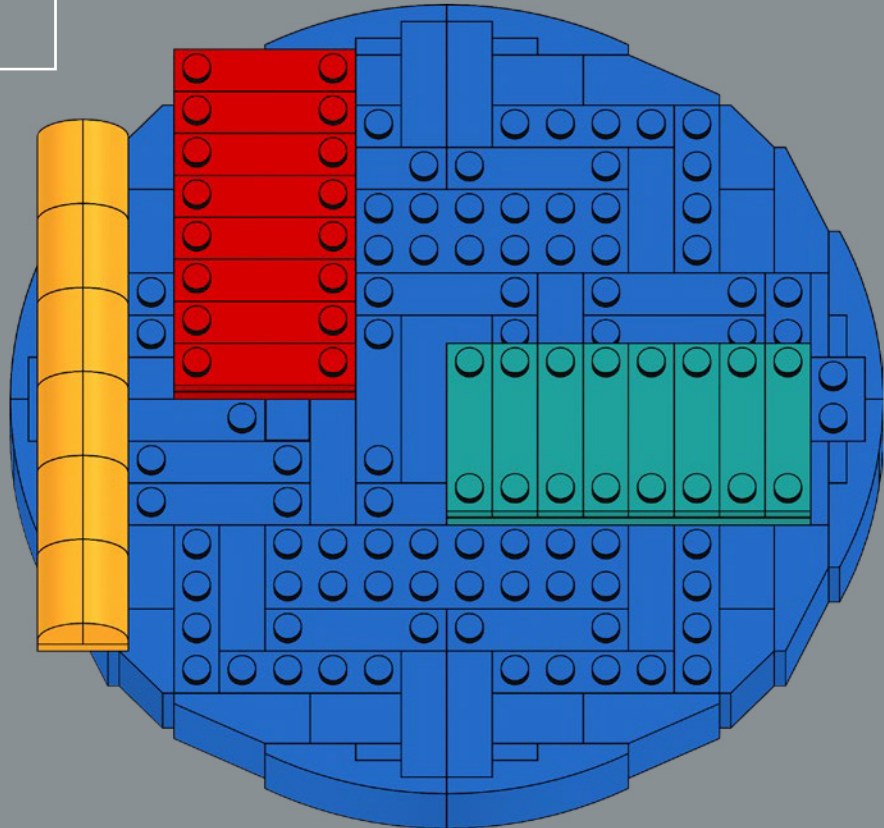

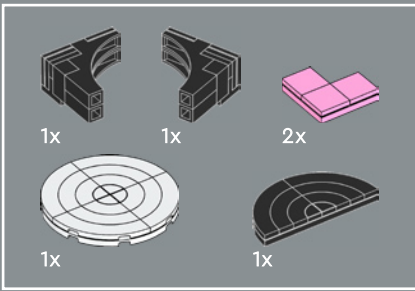

13

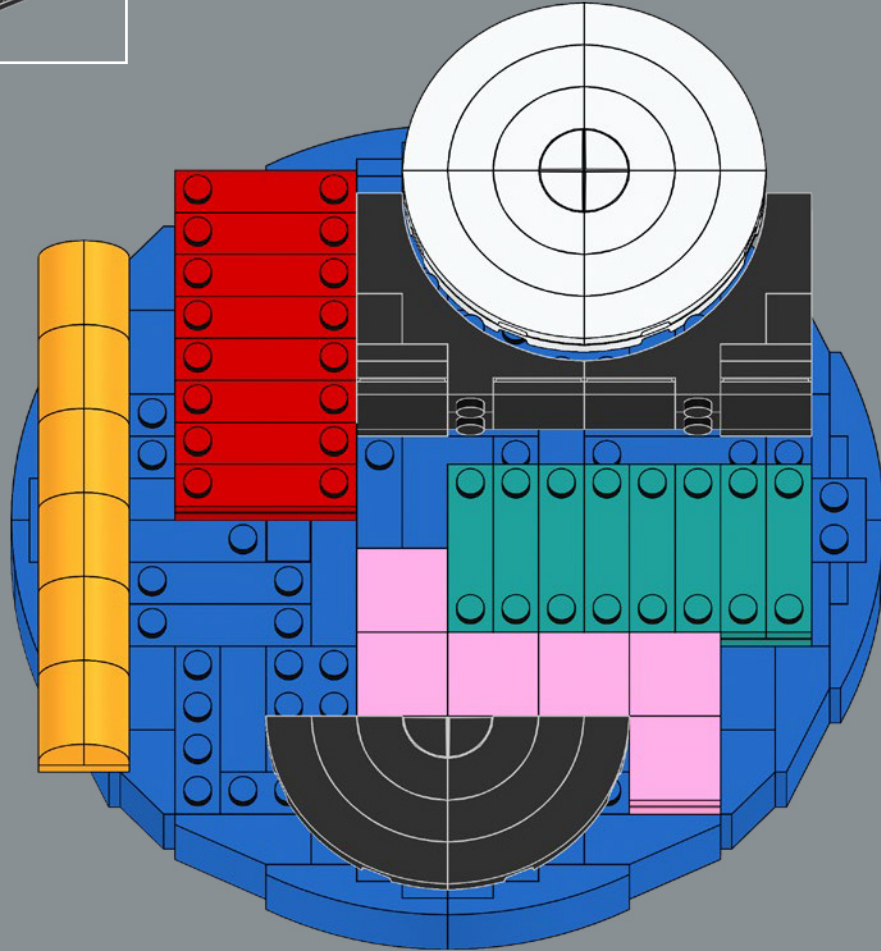

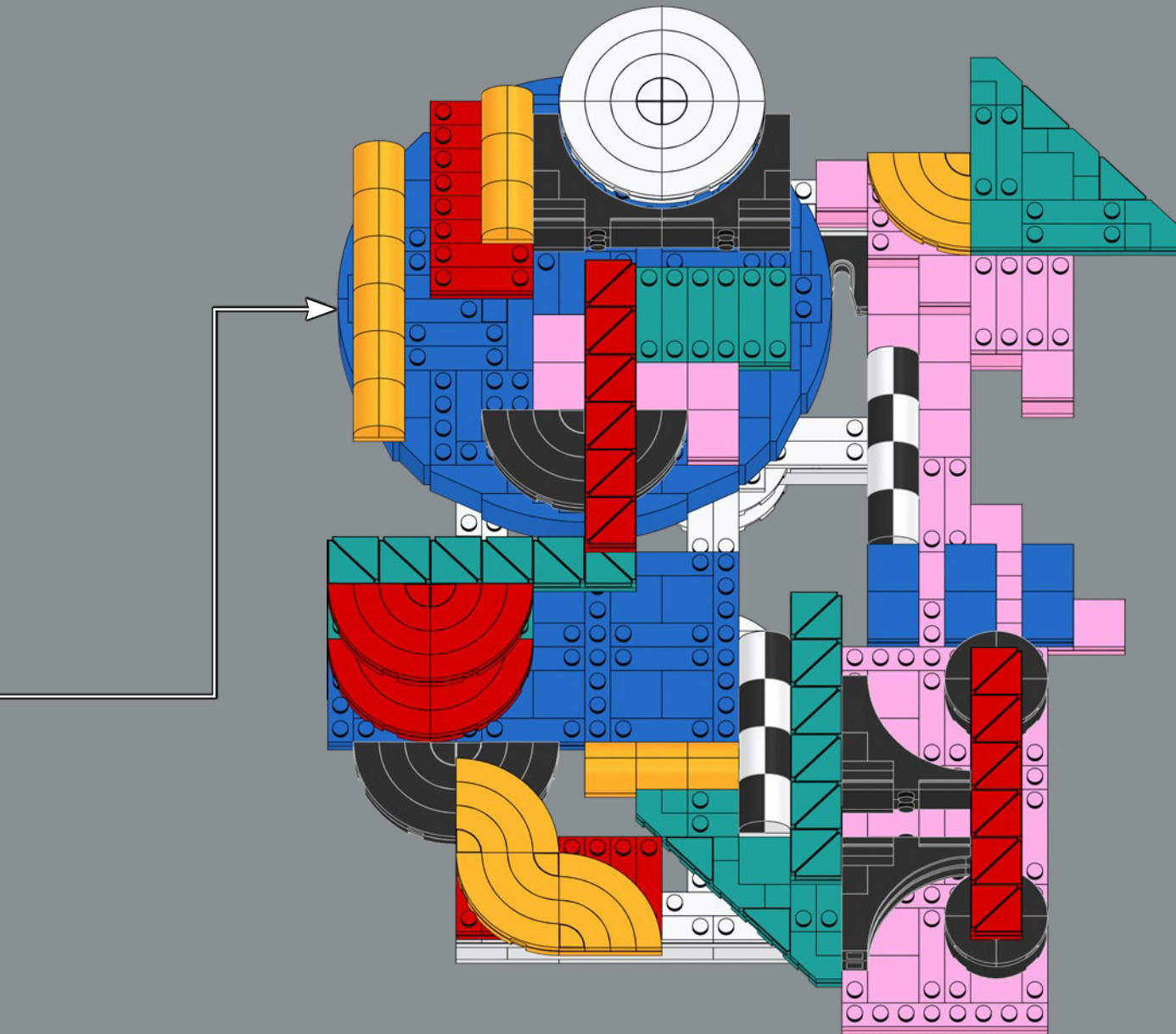

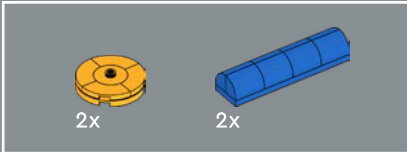
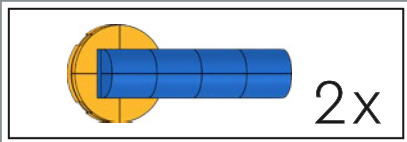

15

1

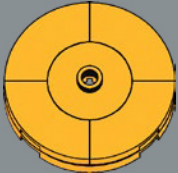

2

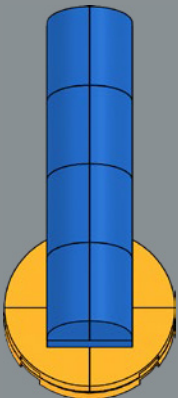

2x

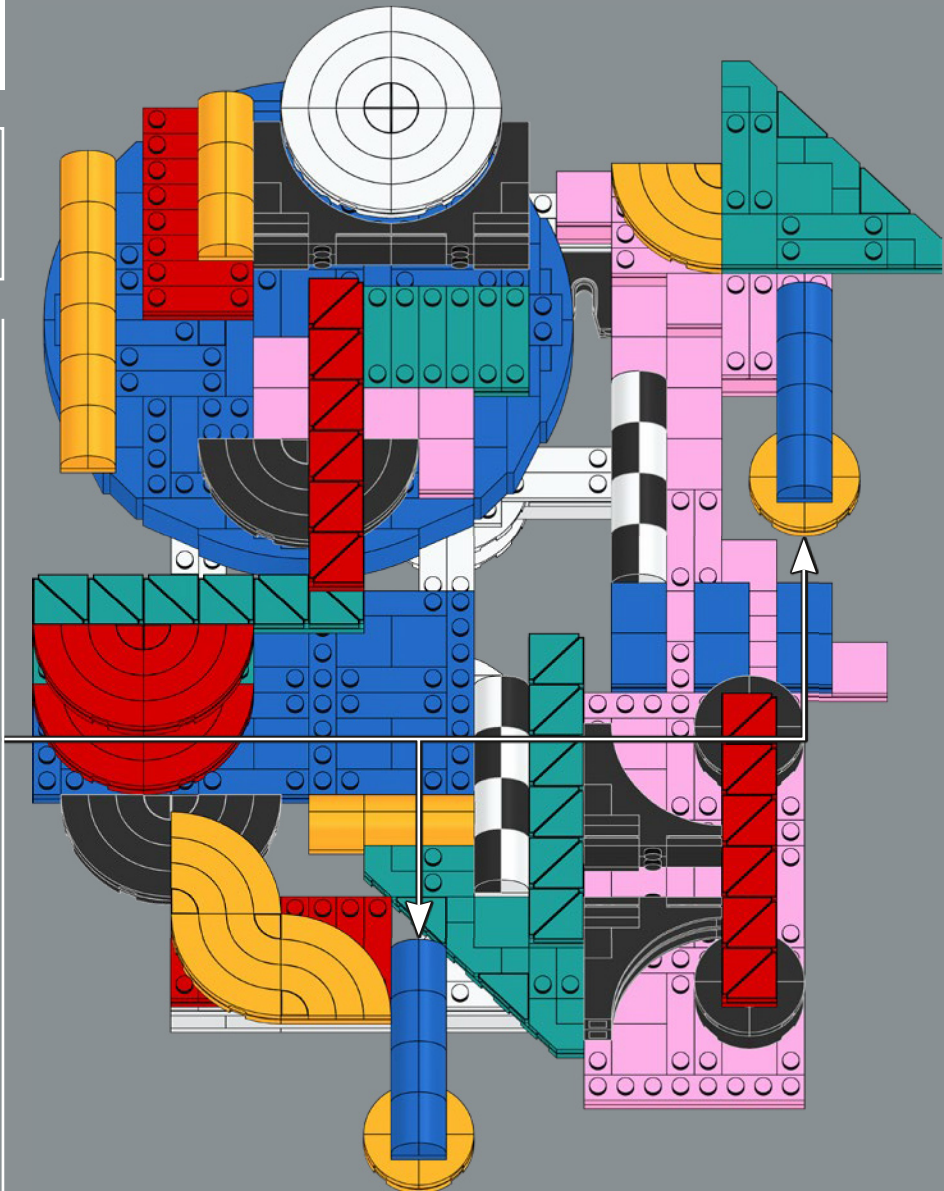

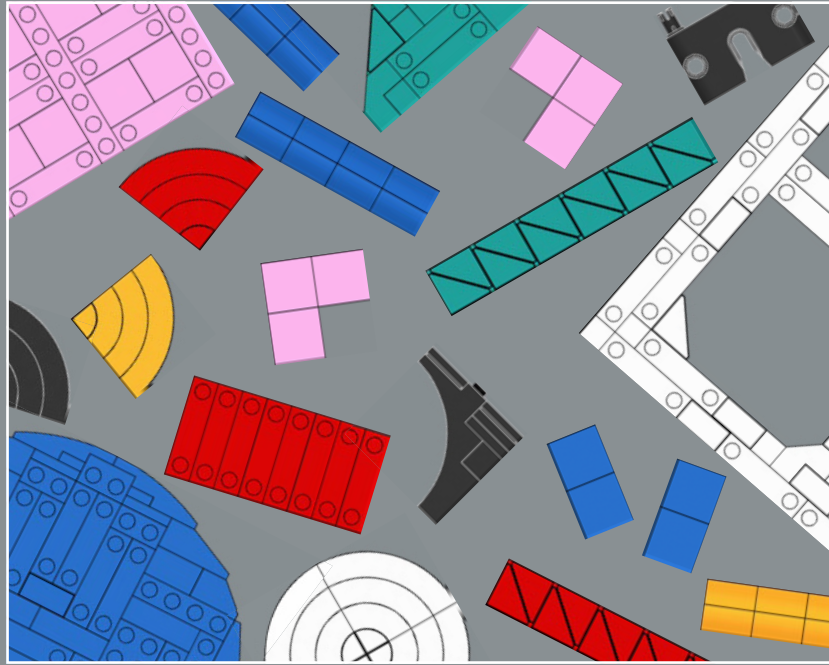

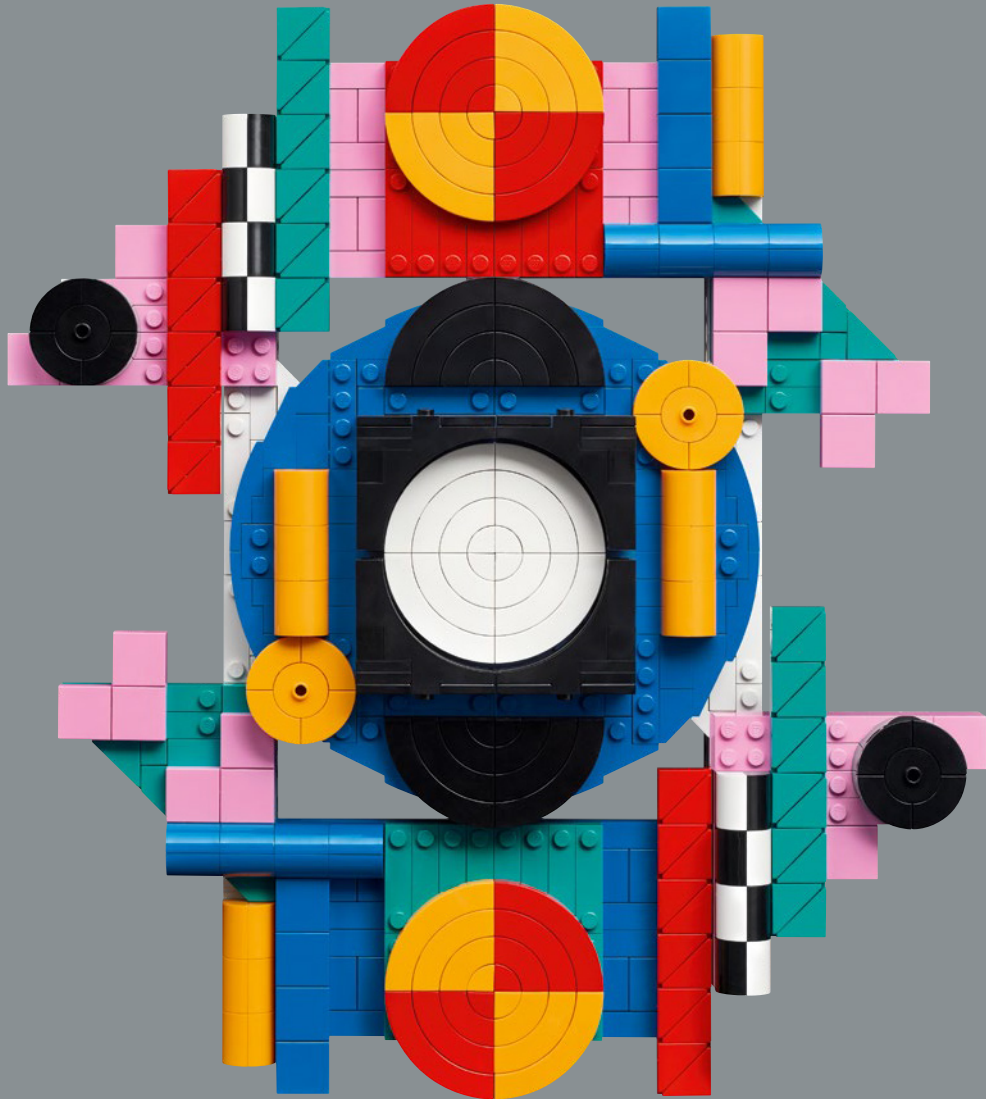



1

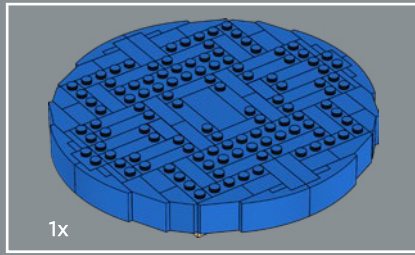
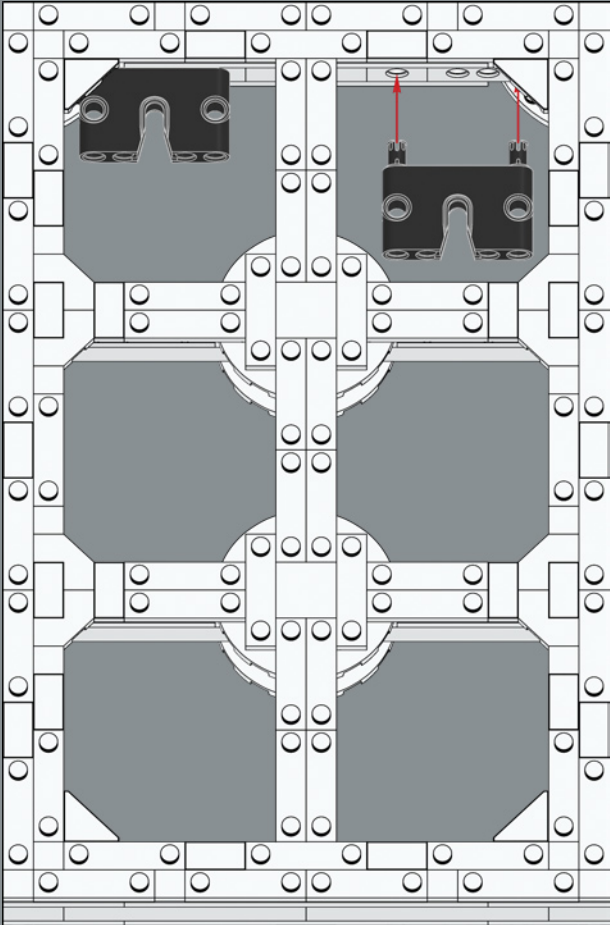

2

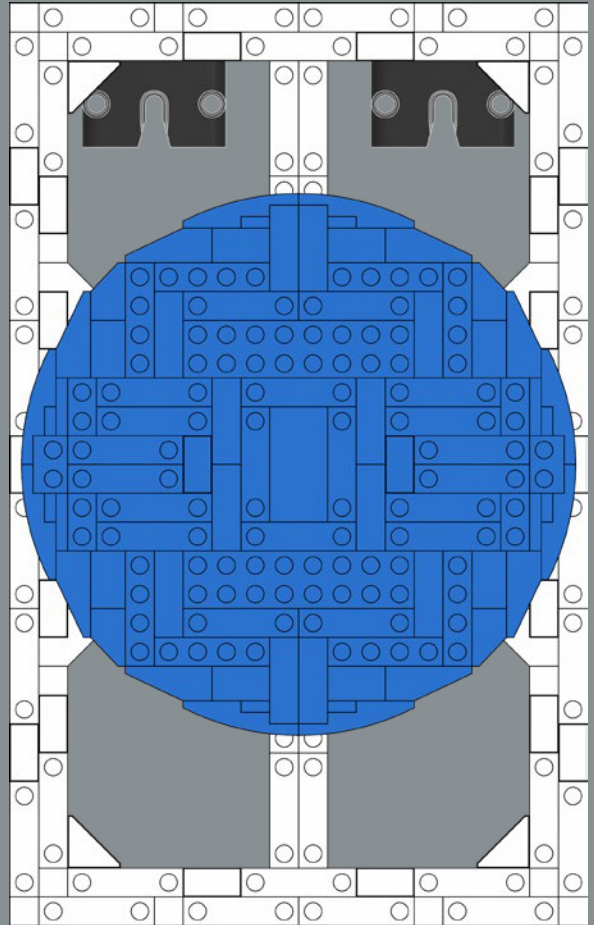

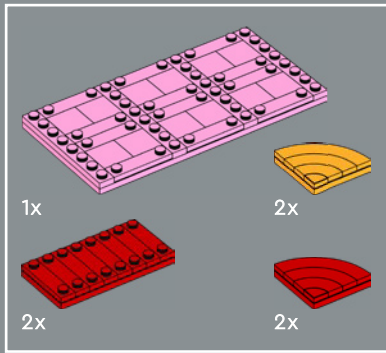

1

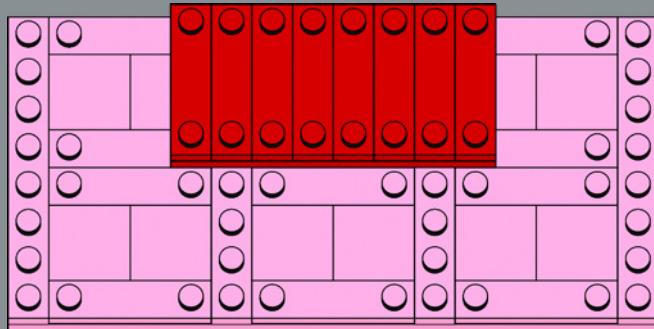

3

2

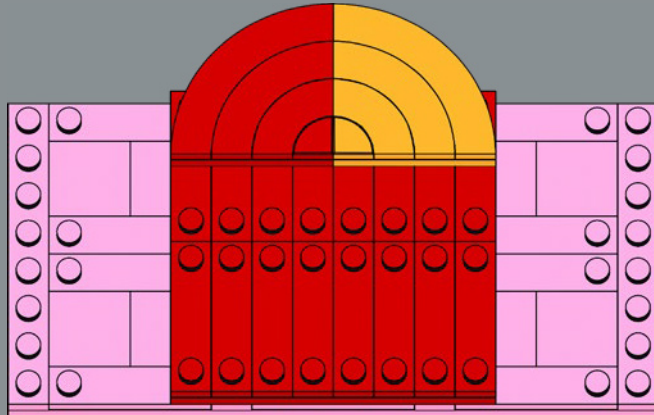

3

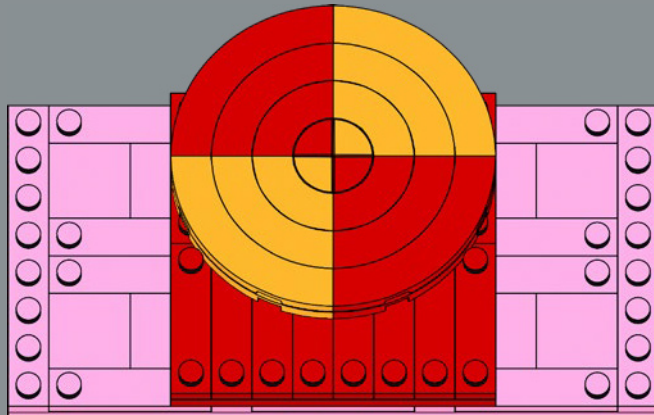

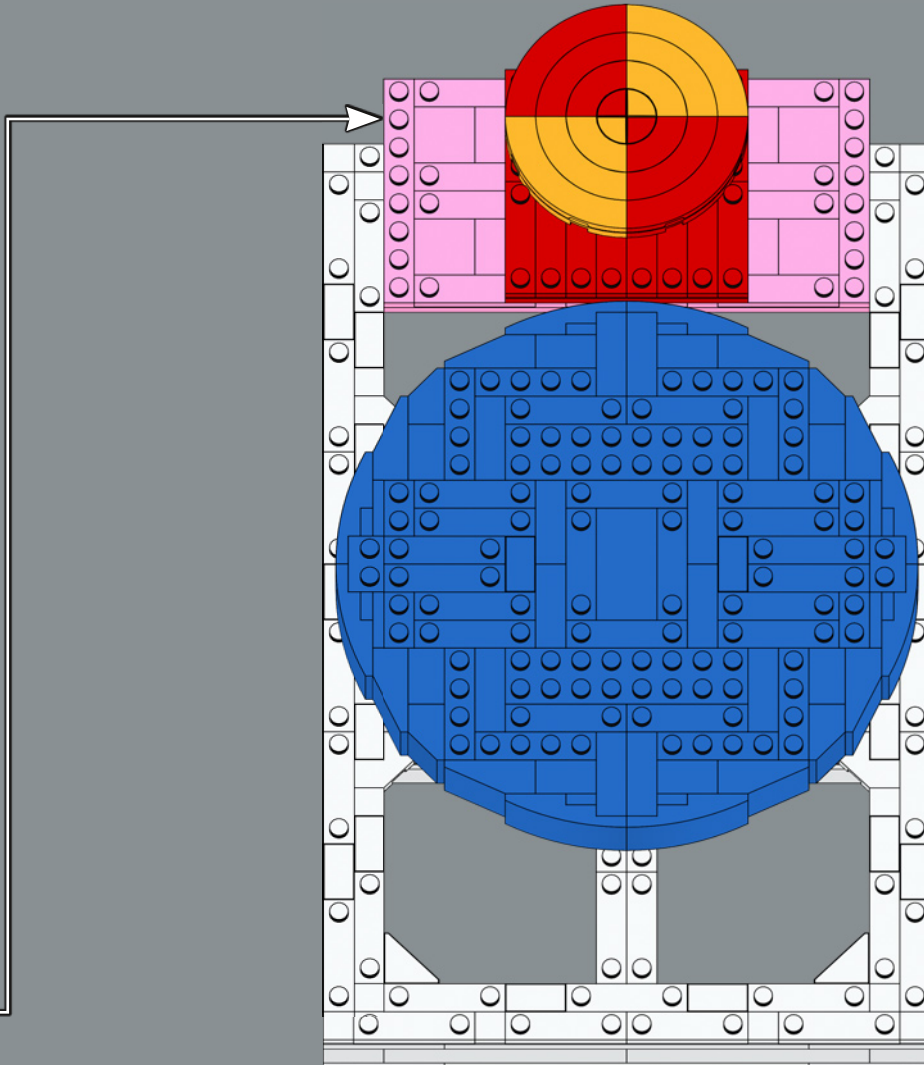

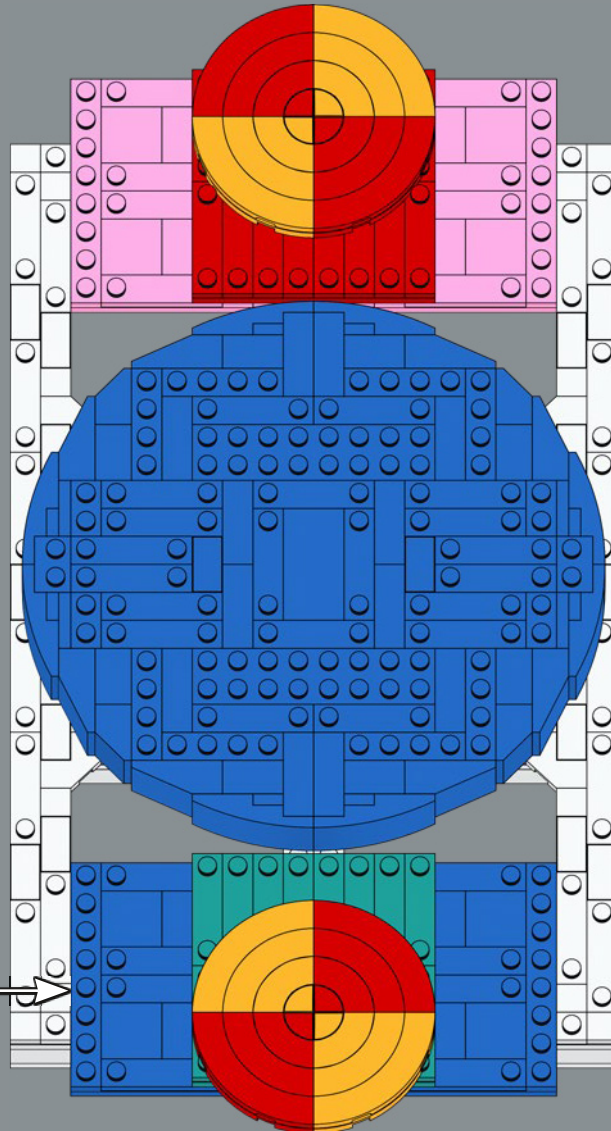

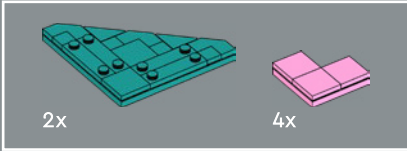
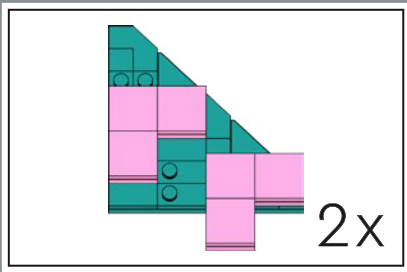

5

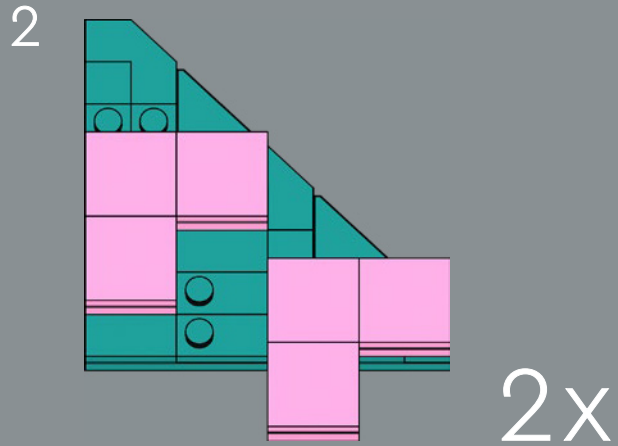
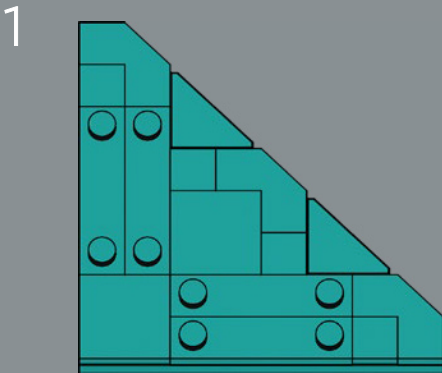

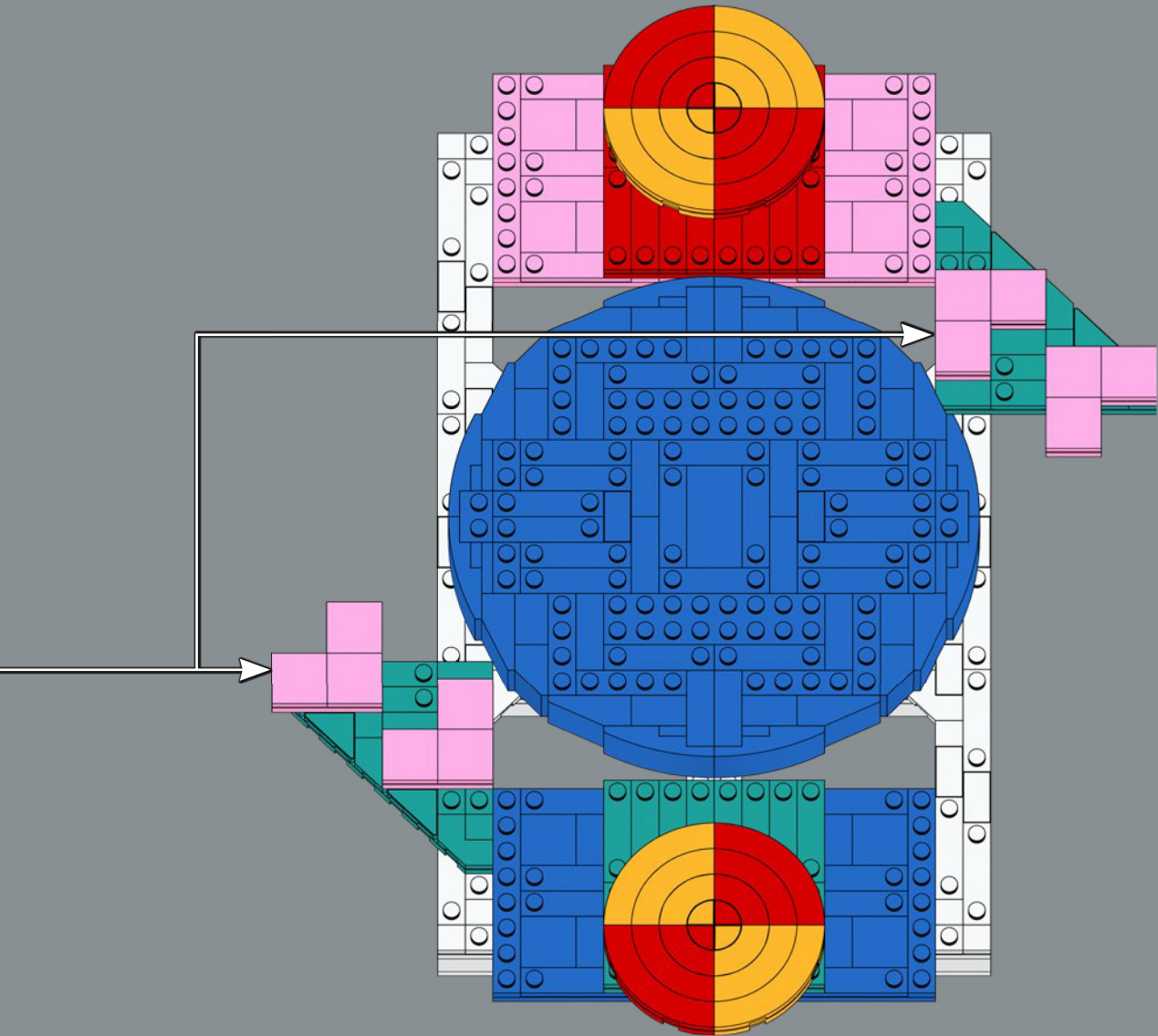

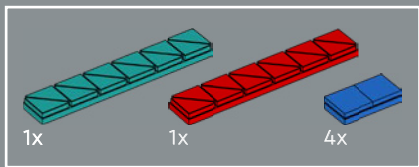

6

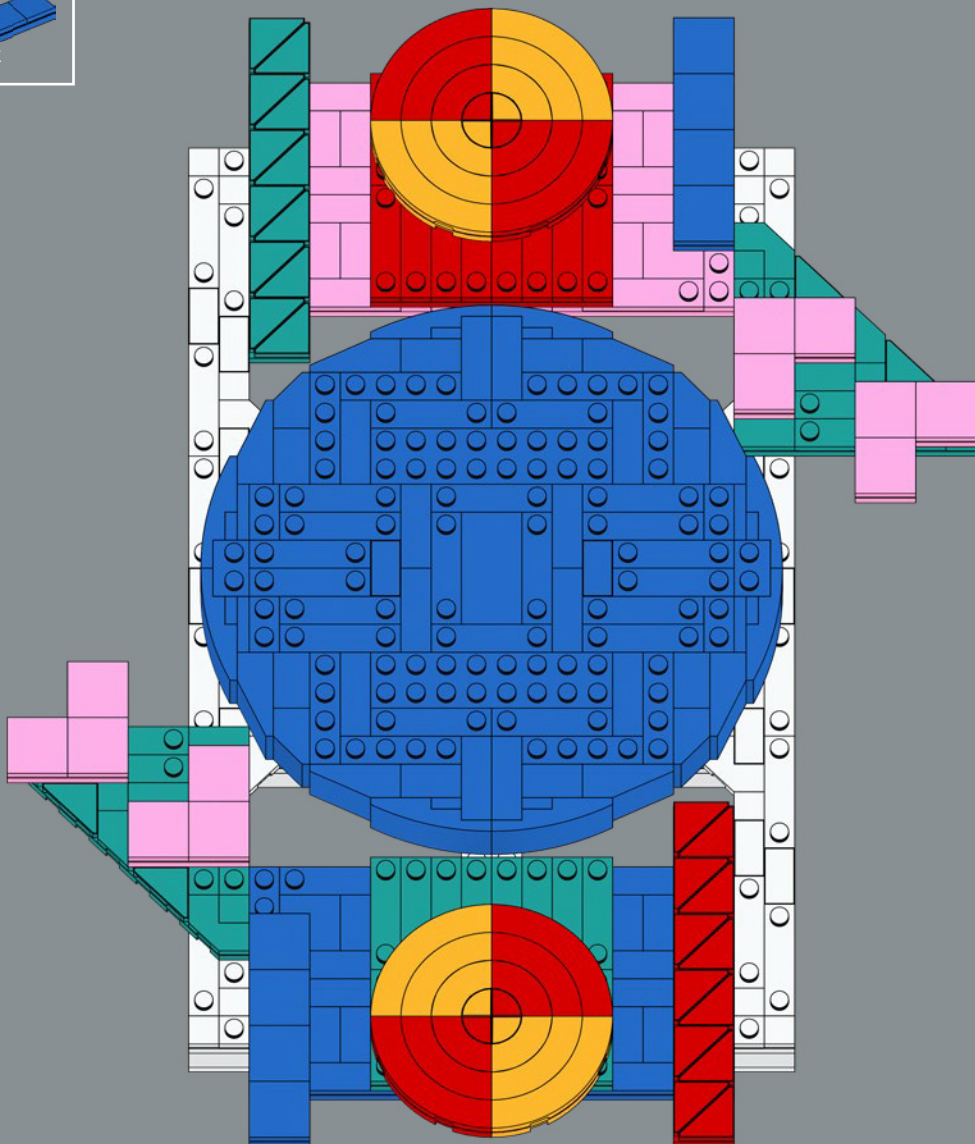

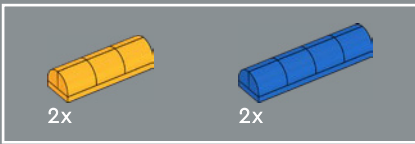

7

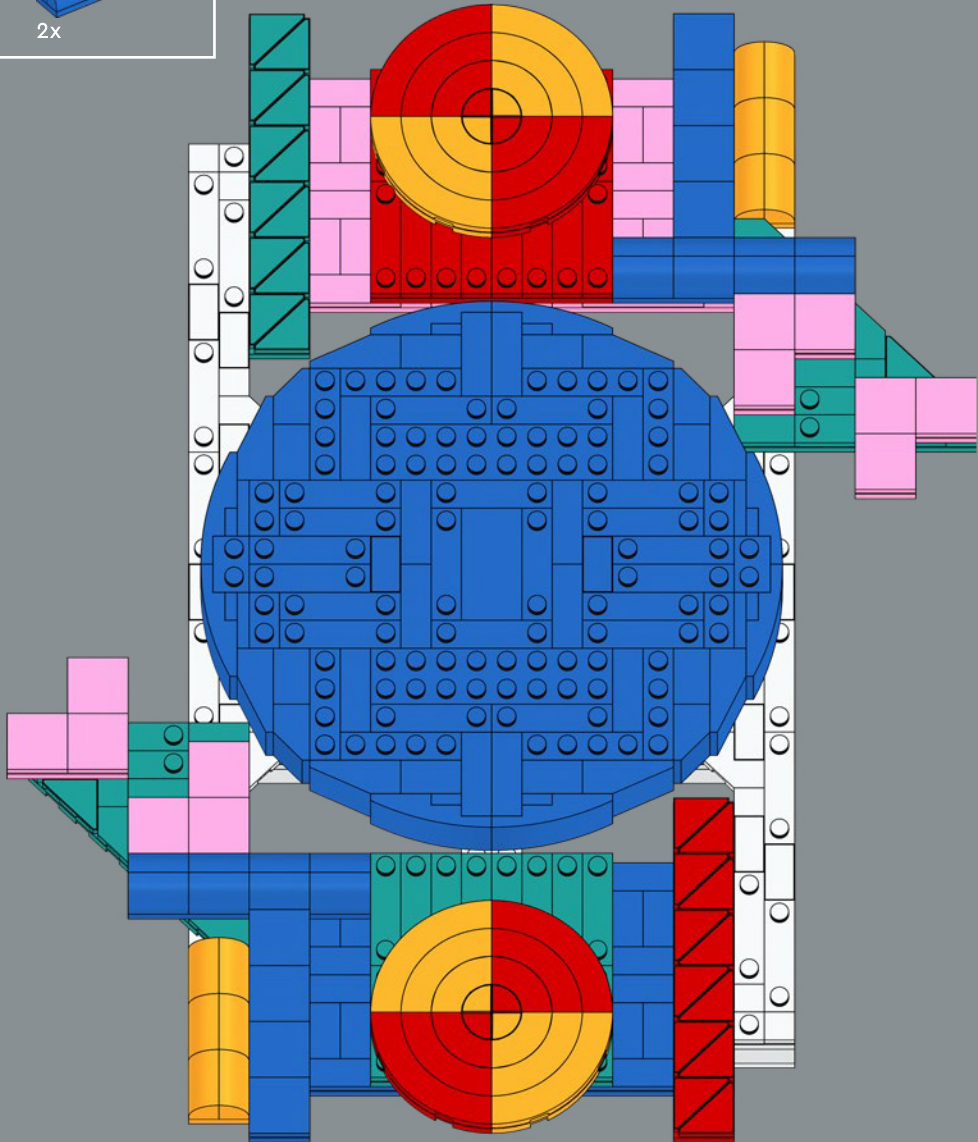

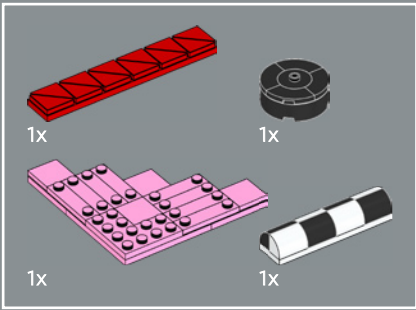

8

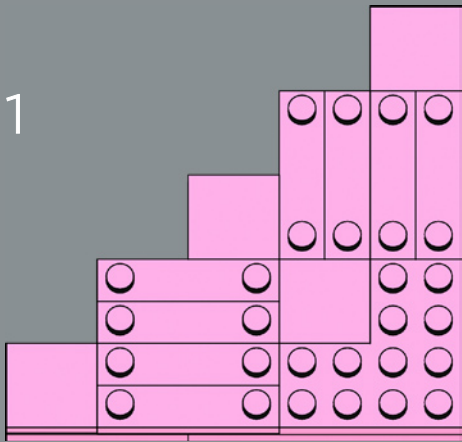

2

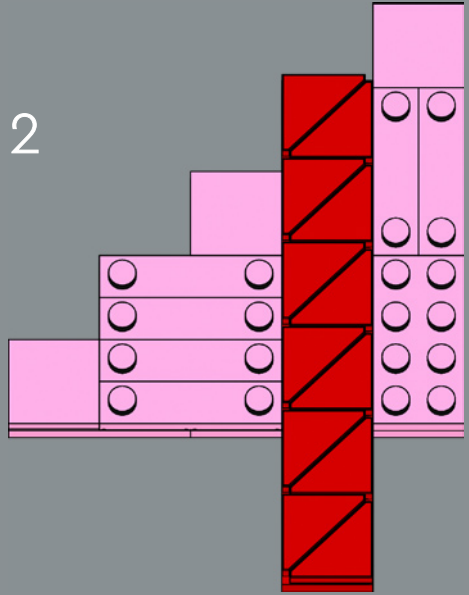

3

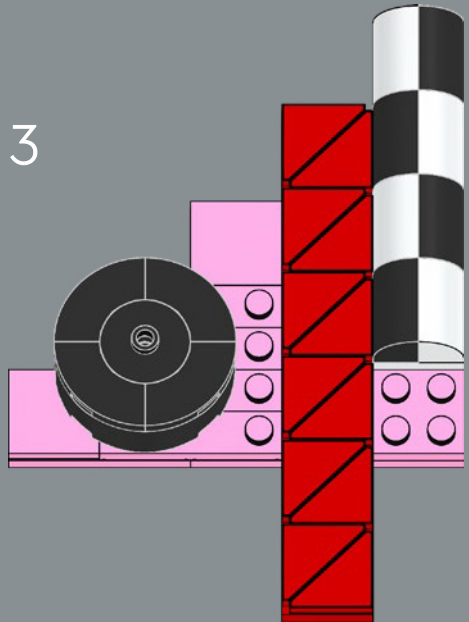

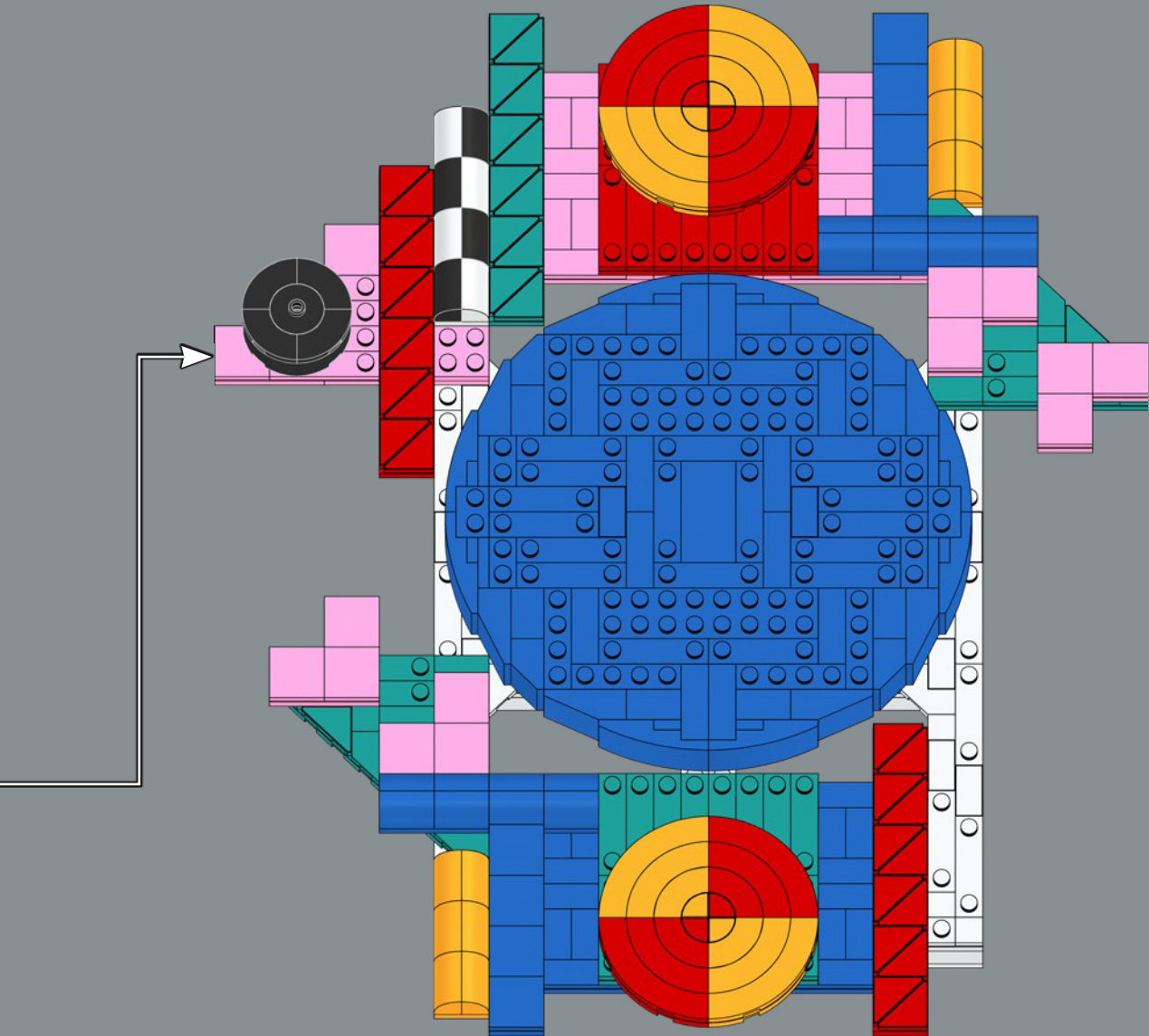

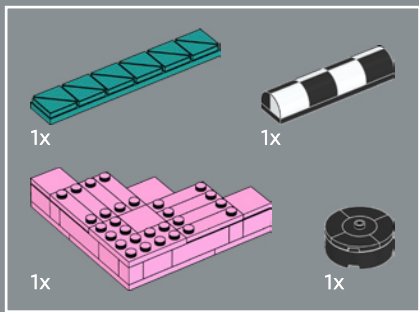

9

1

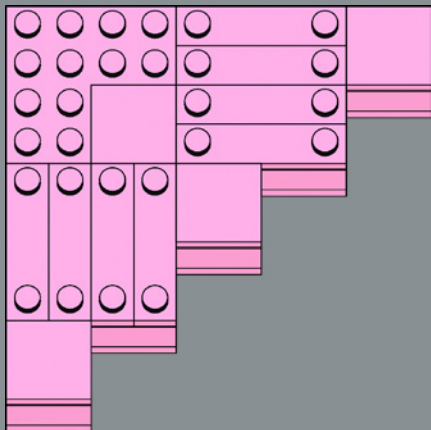

2

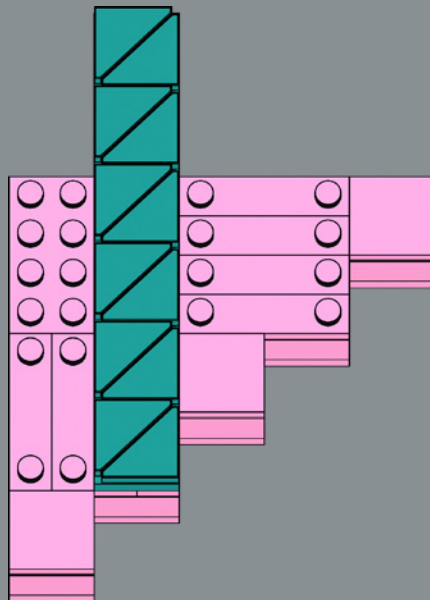

3

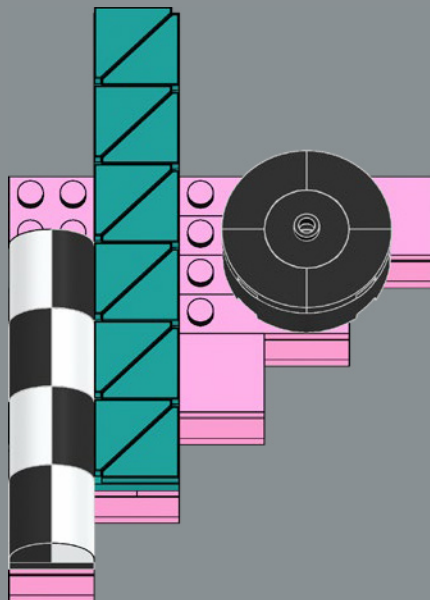

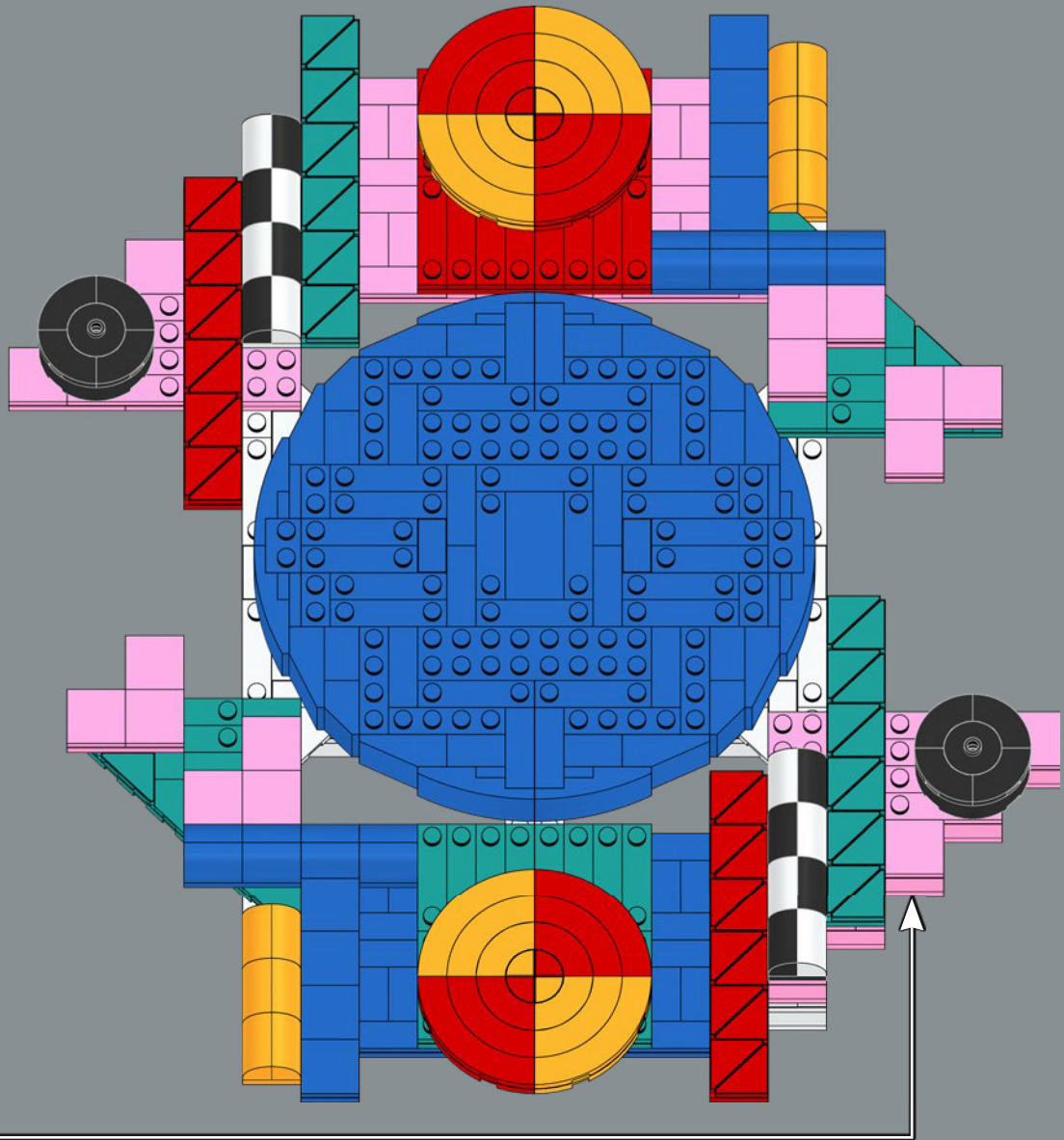

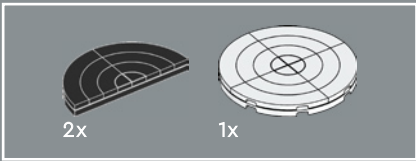

10

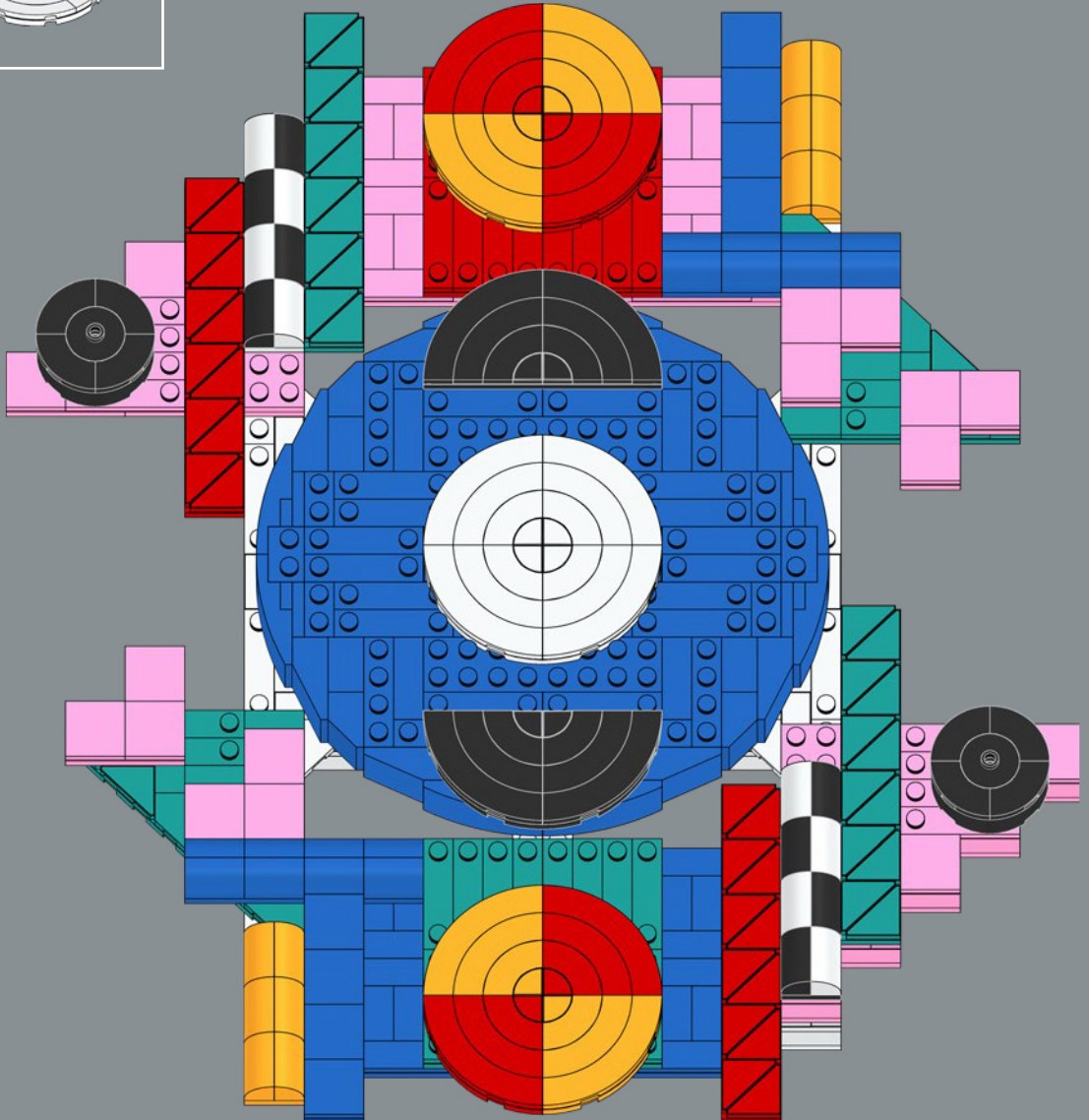

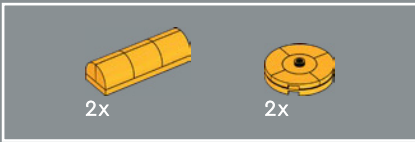

11

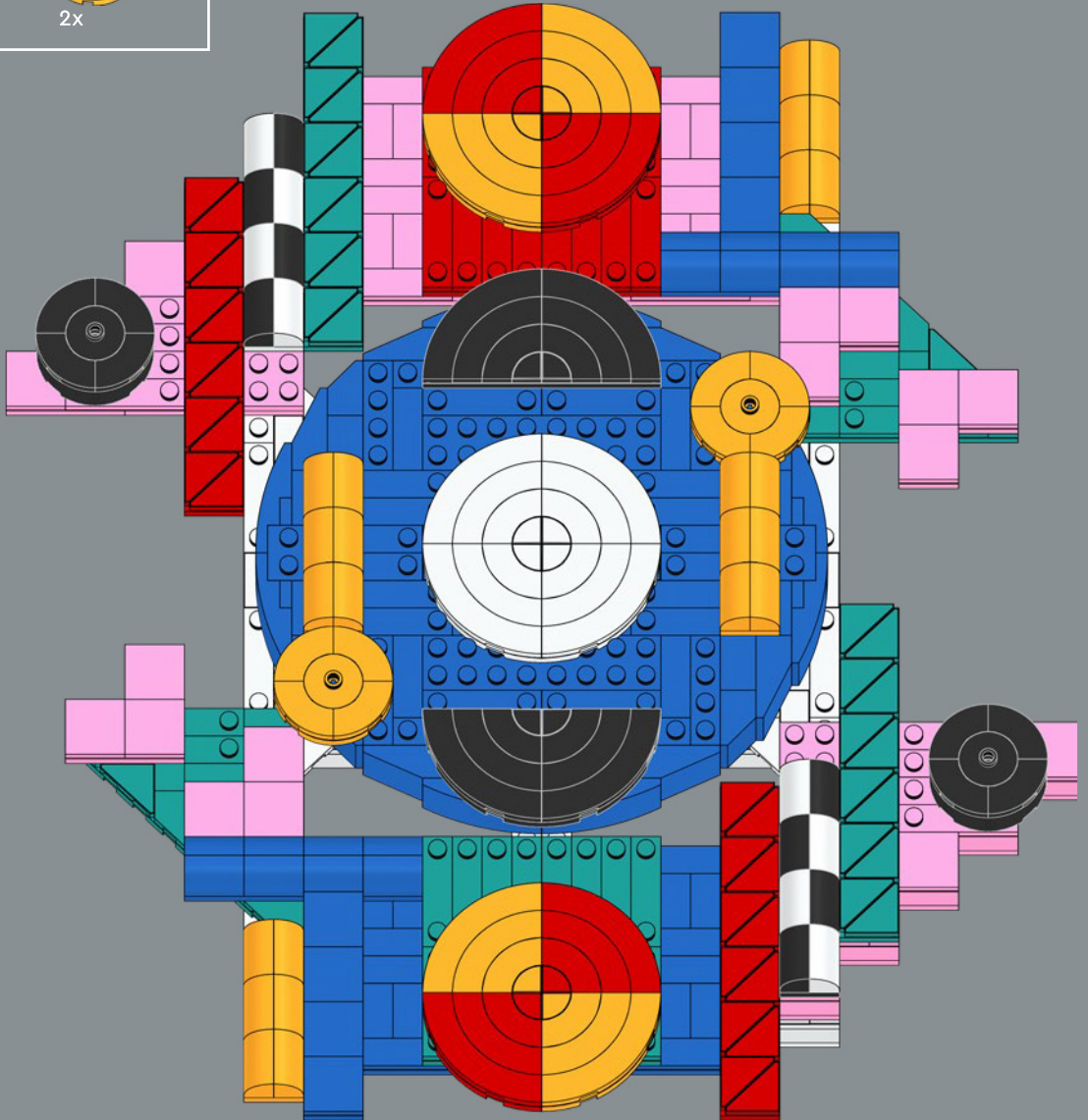

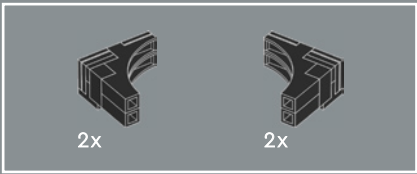

12

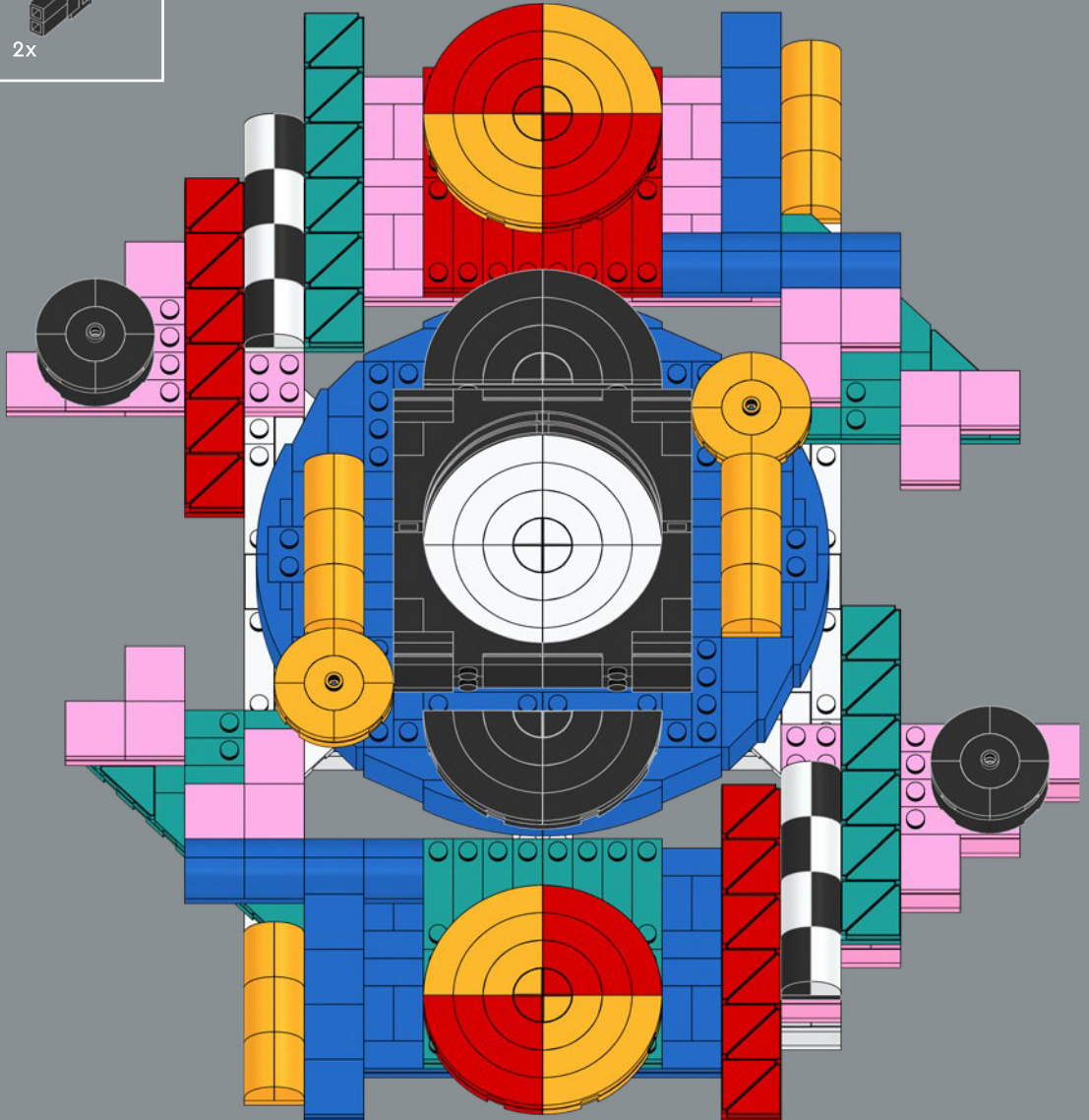

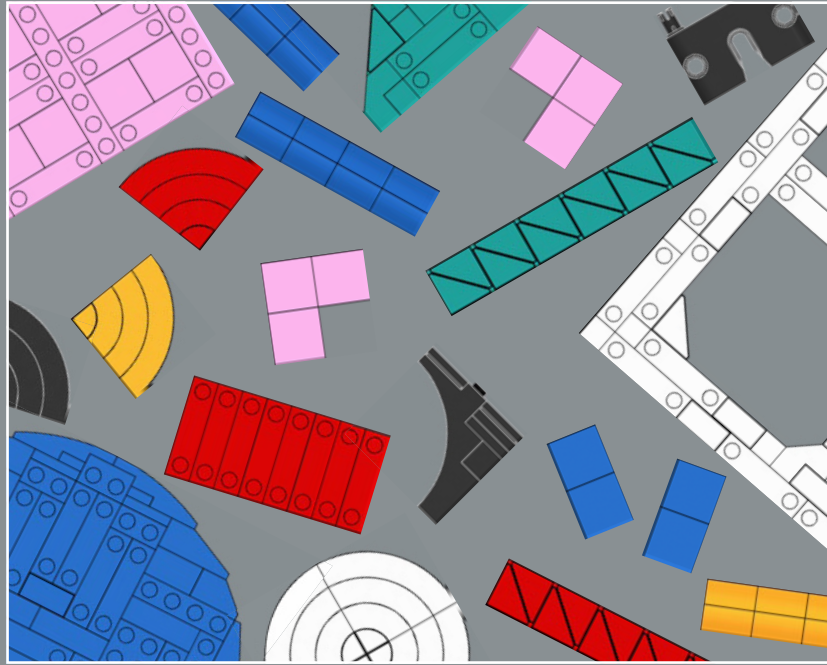

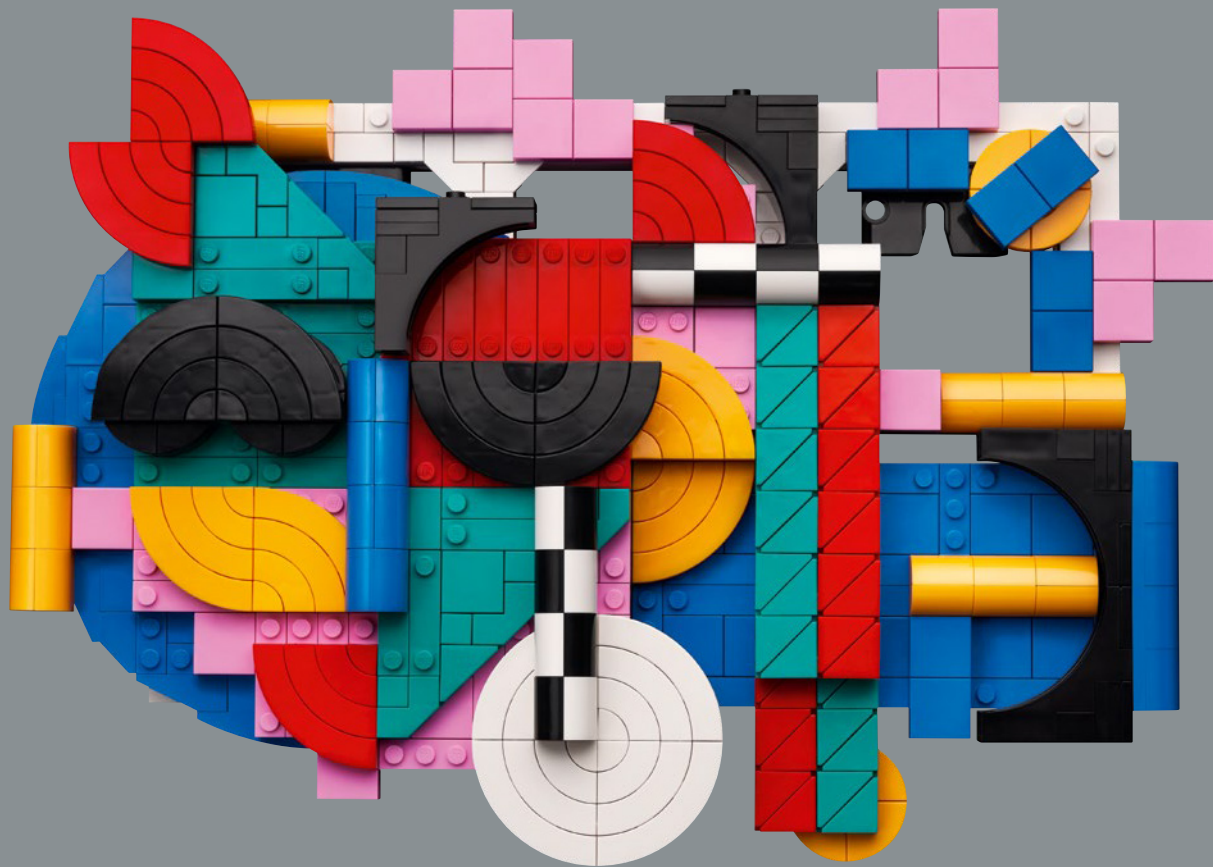



1

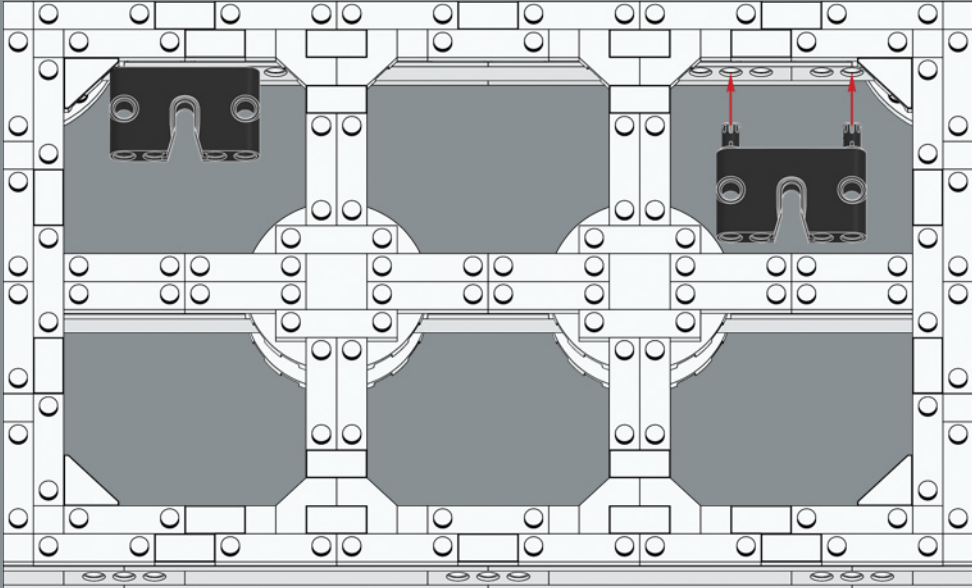

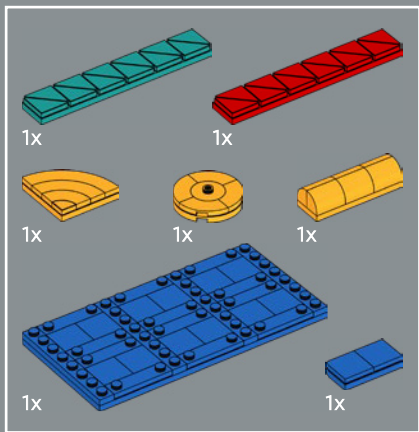

2

1

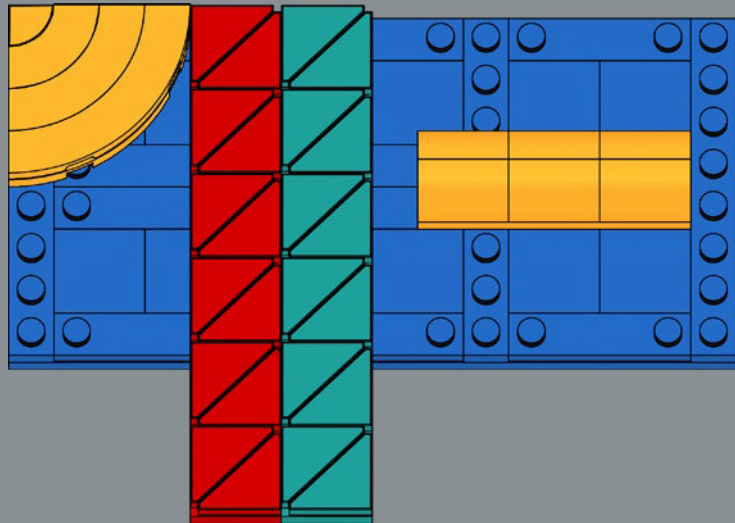

2

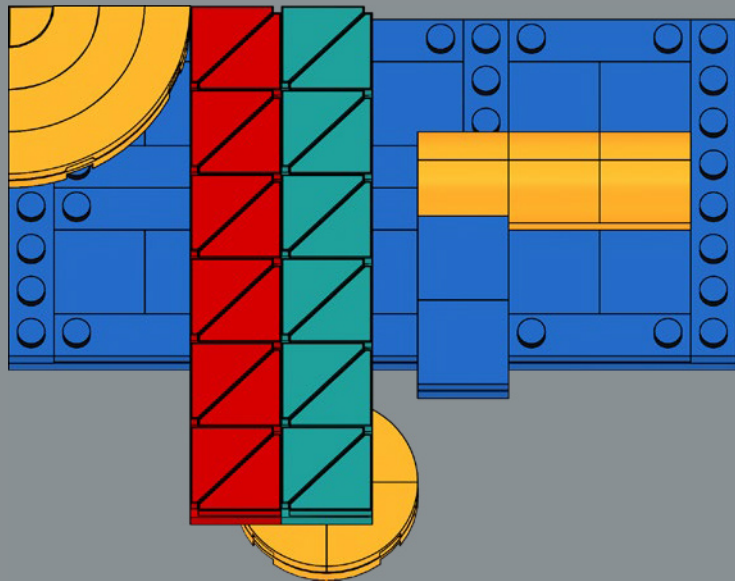

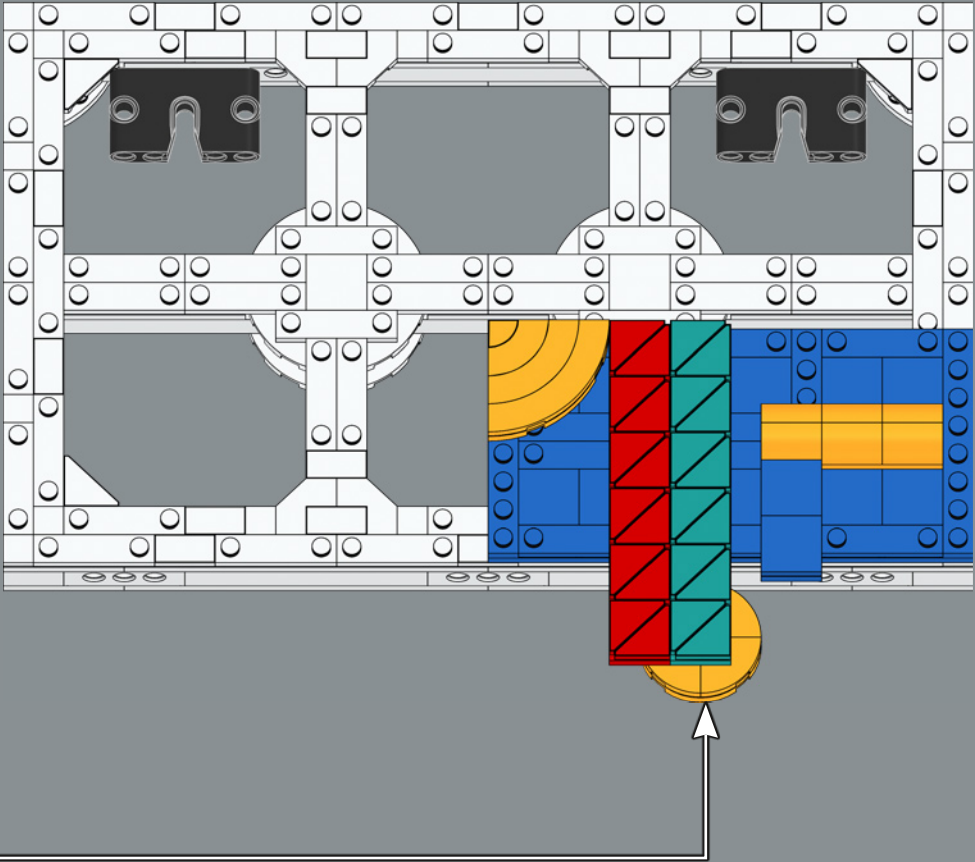

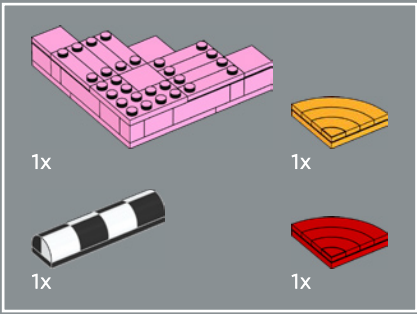

3

1

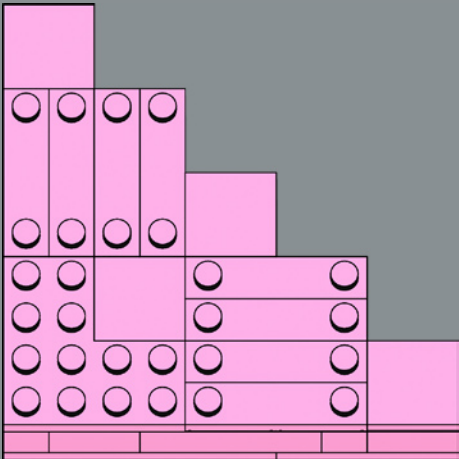

2

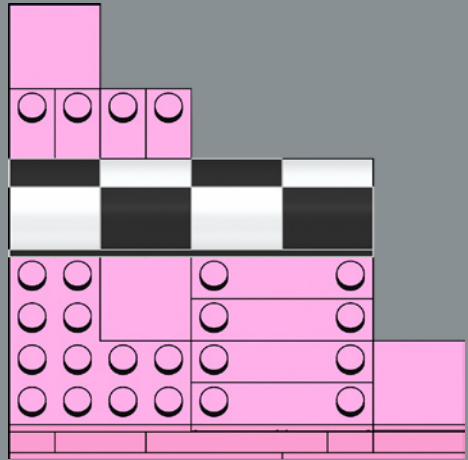

3

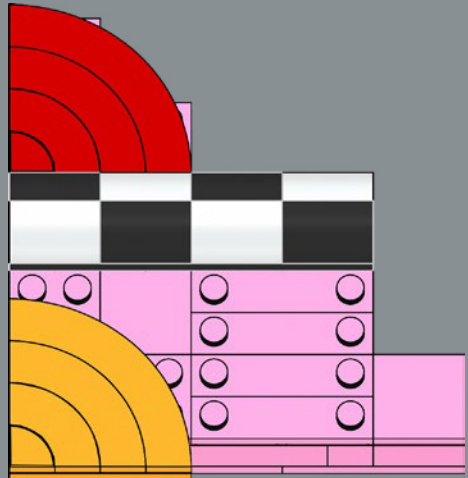

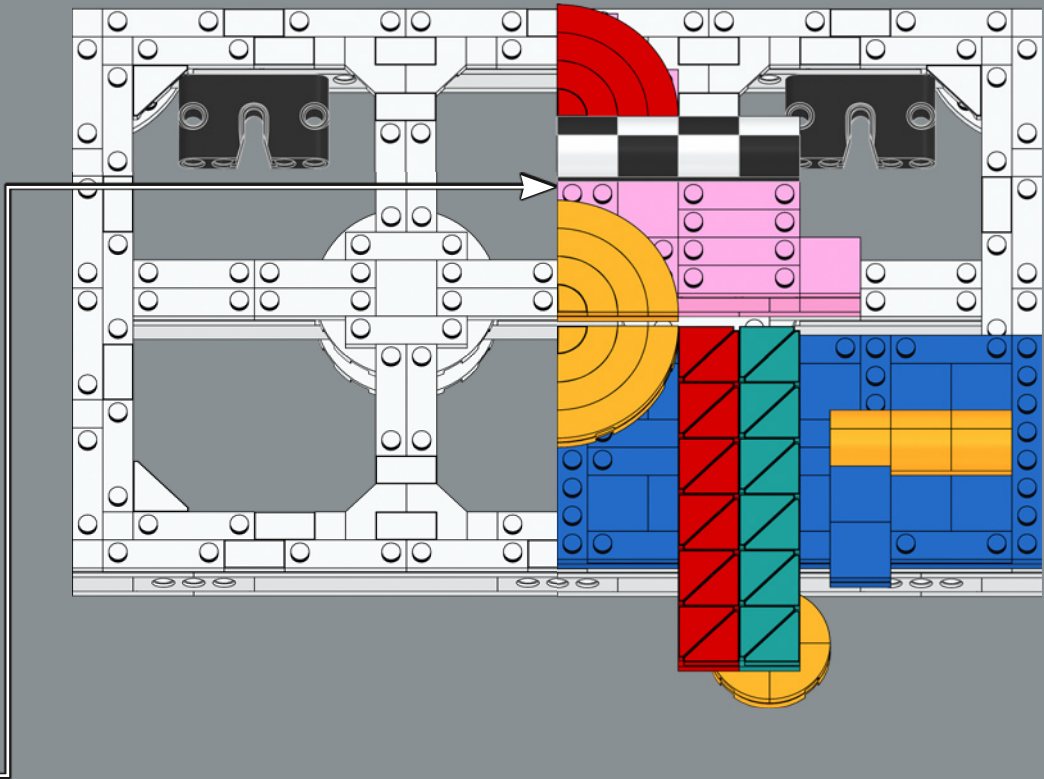

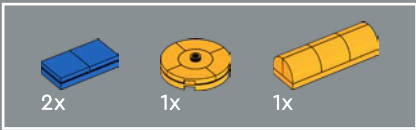

4

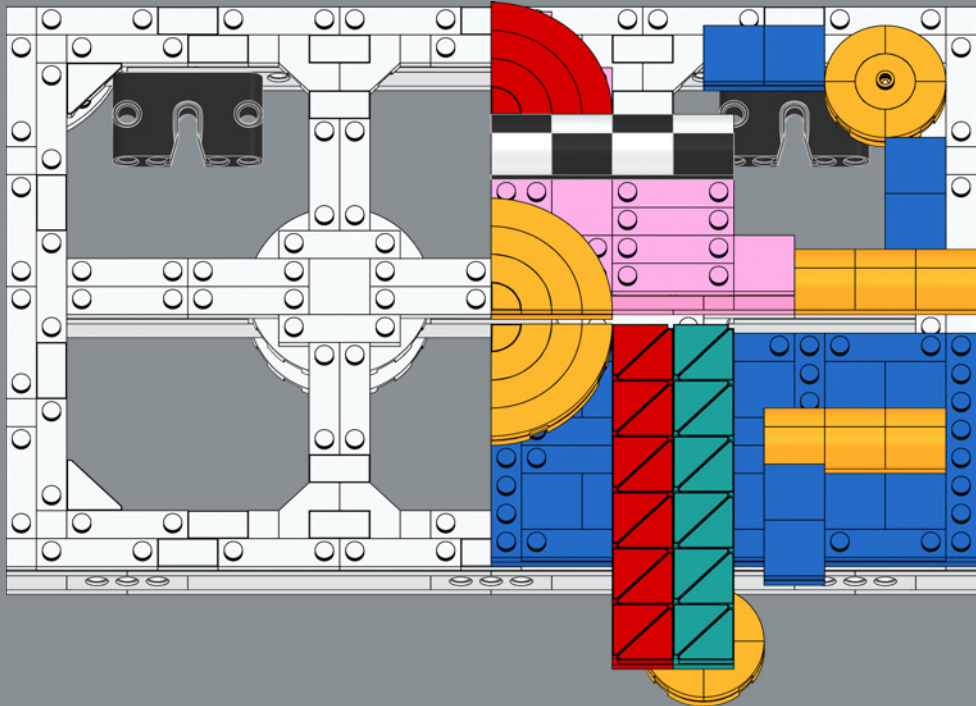

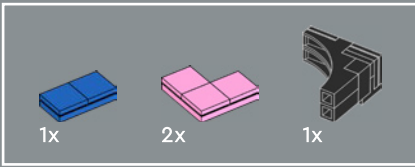

5

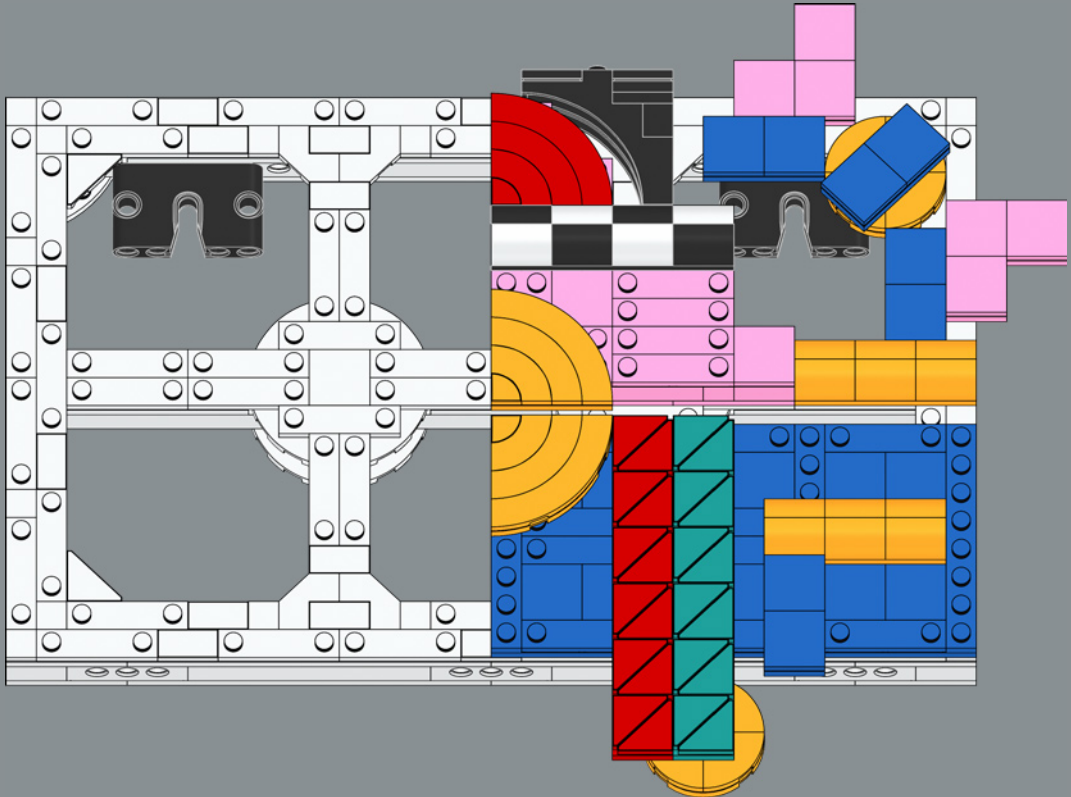

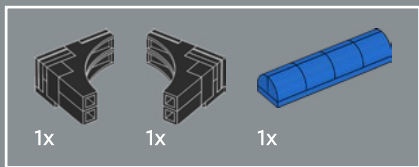

6

1

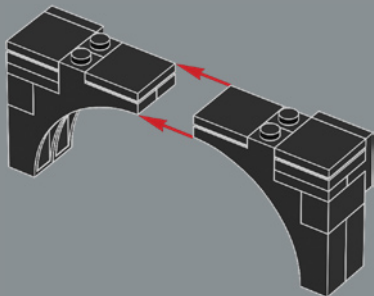

2

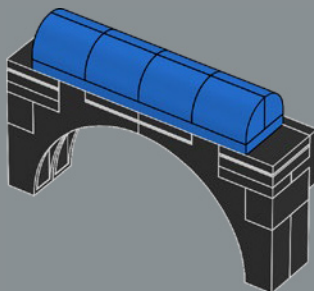

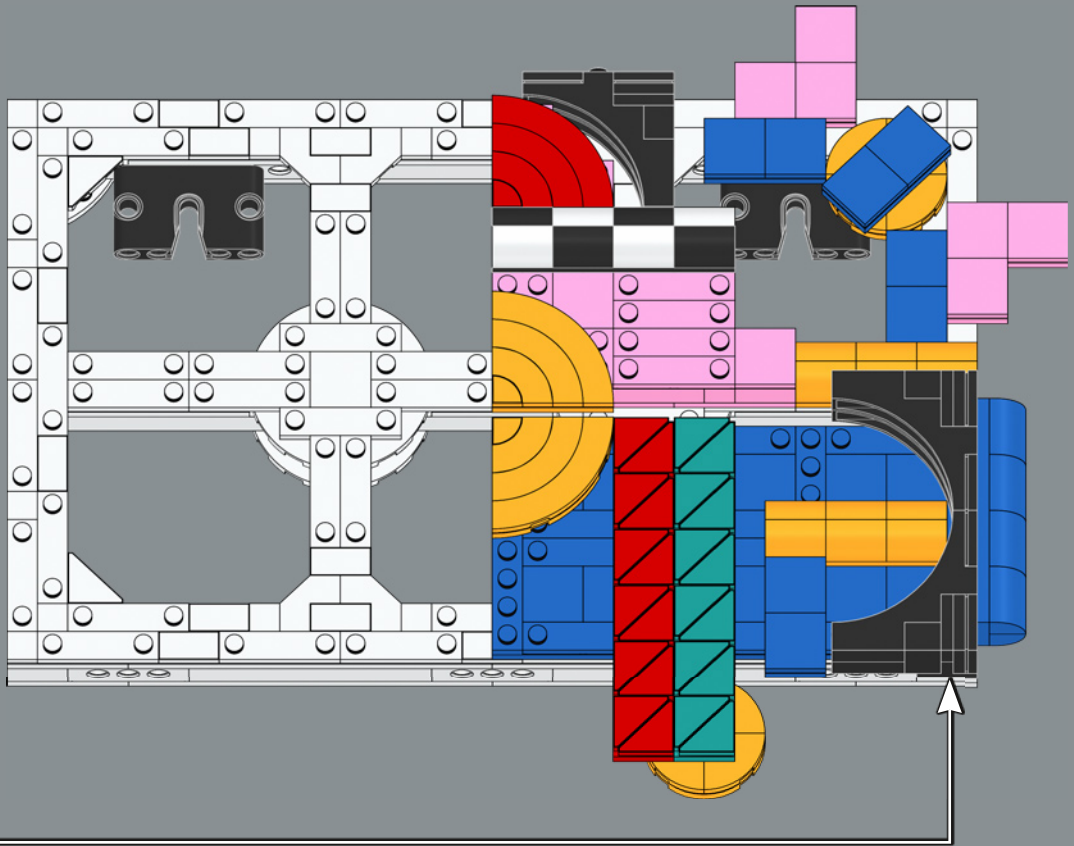

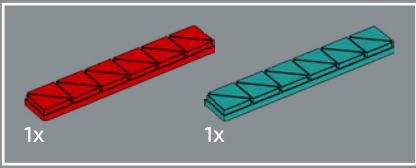

7

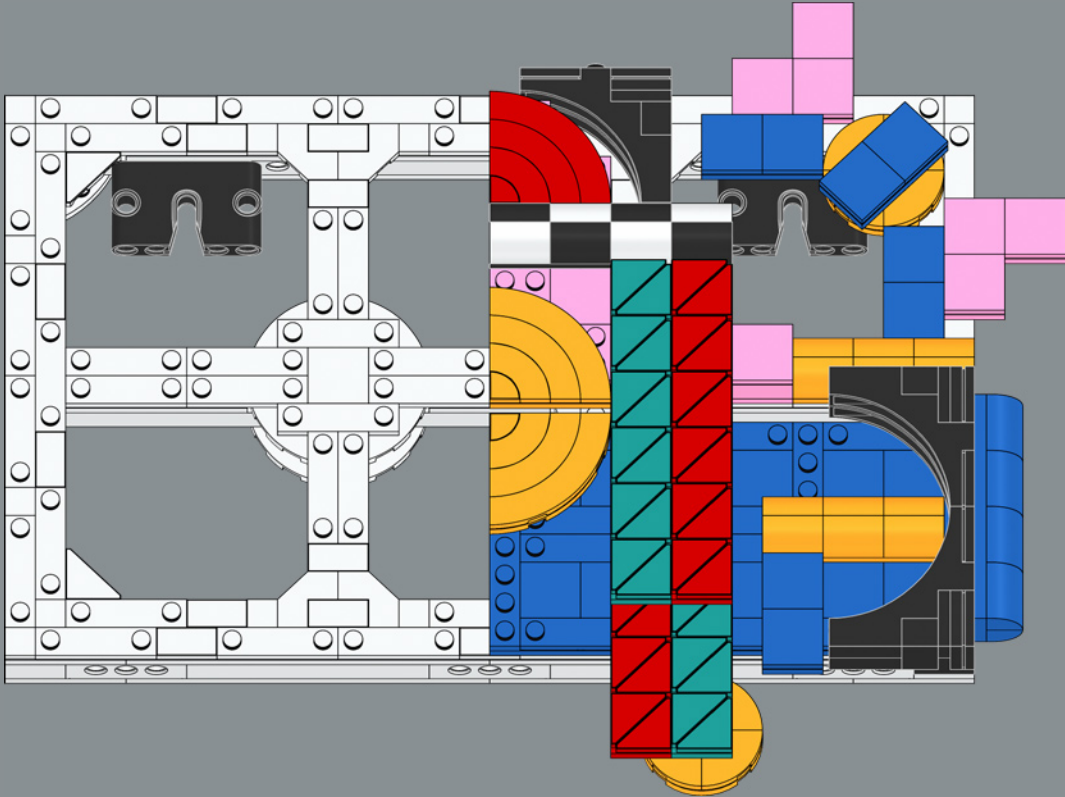

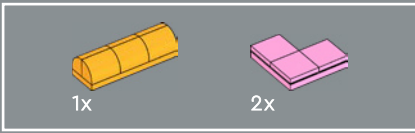

8

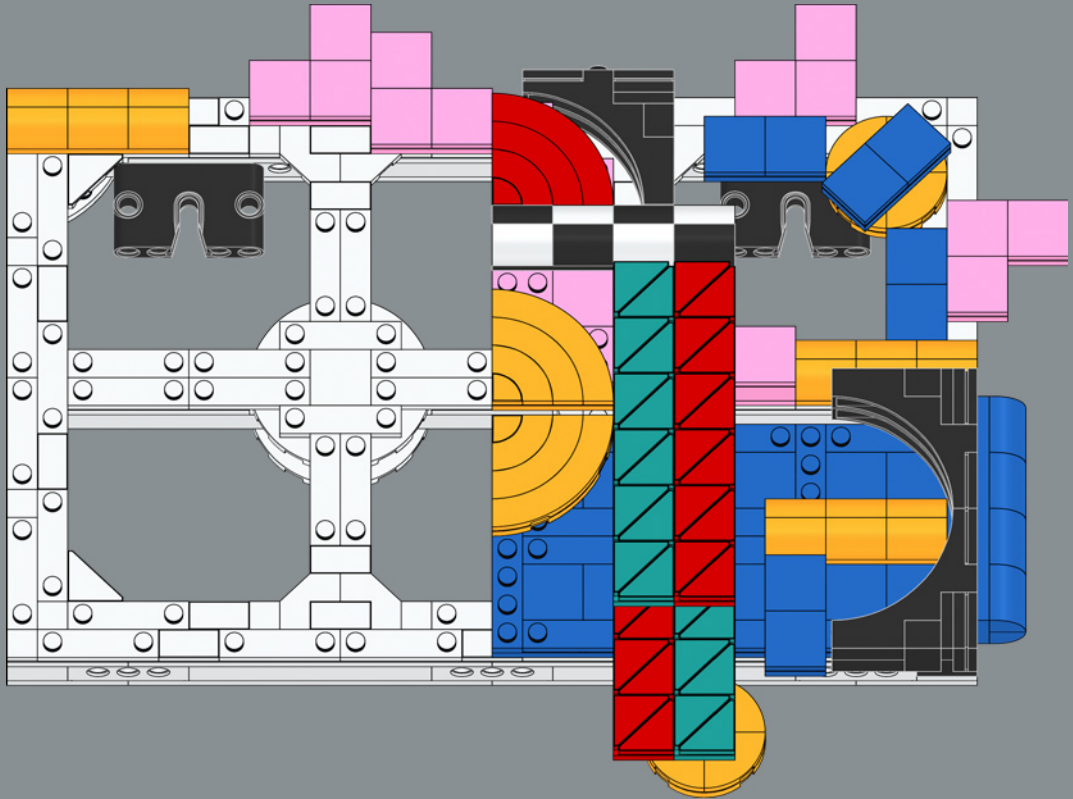

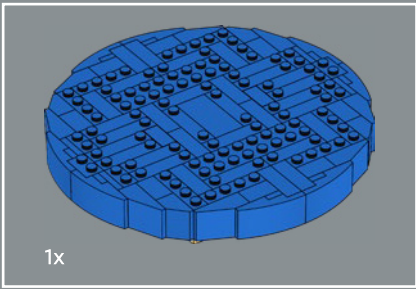

9

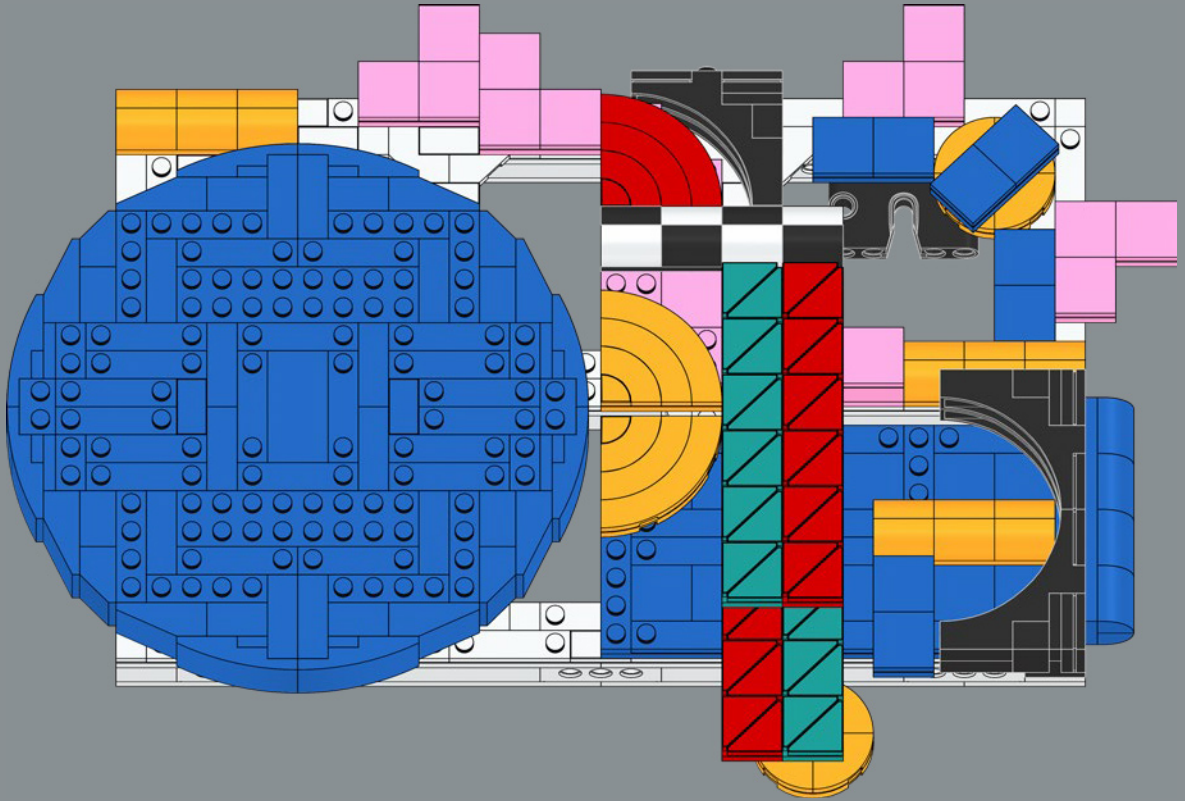

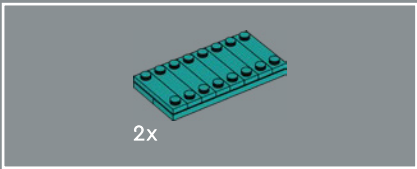

10

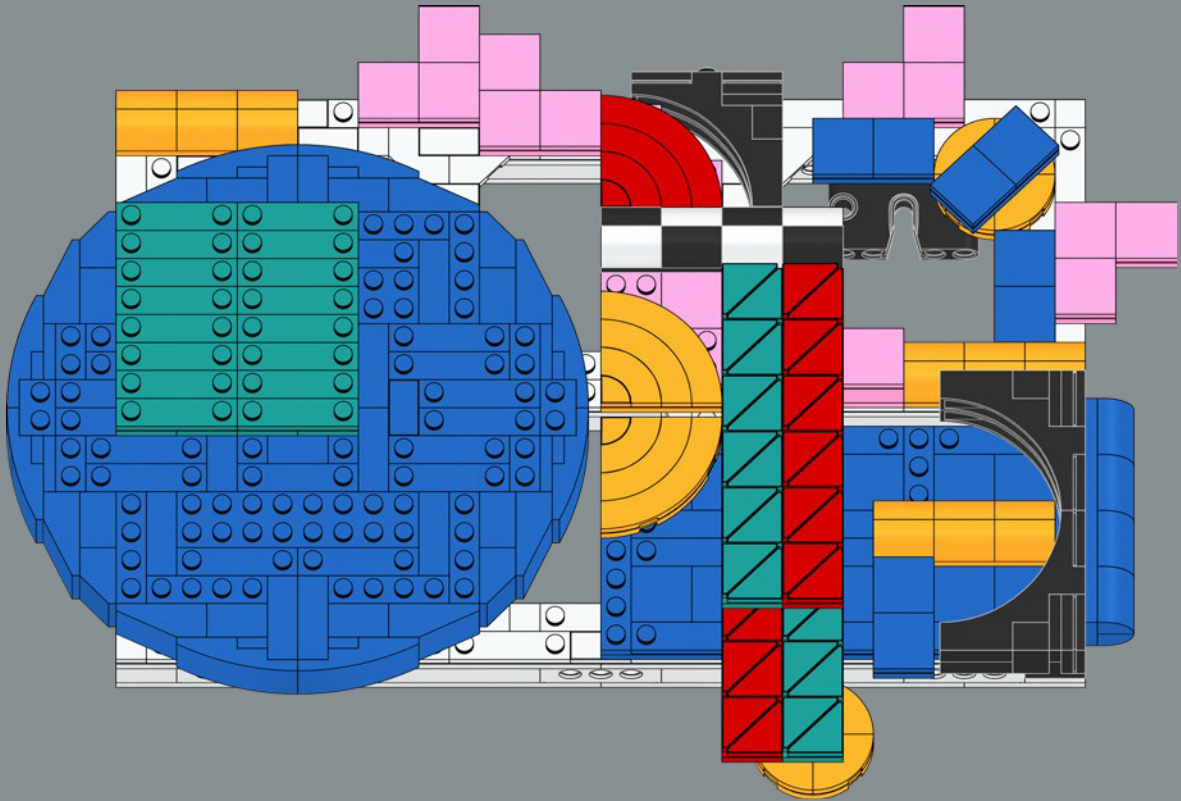

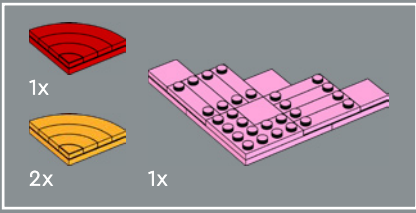

11

1

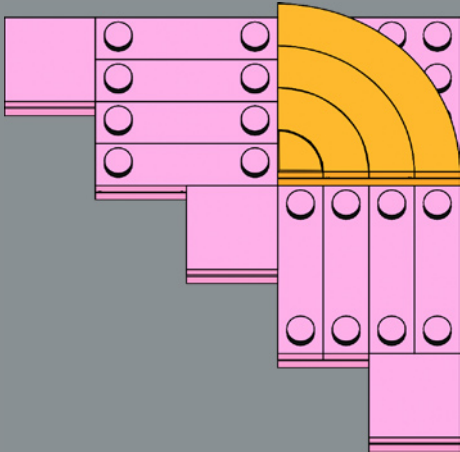

2

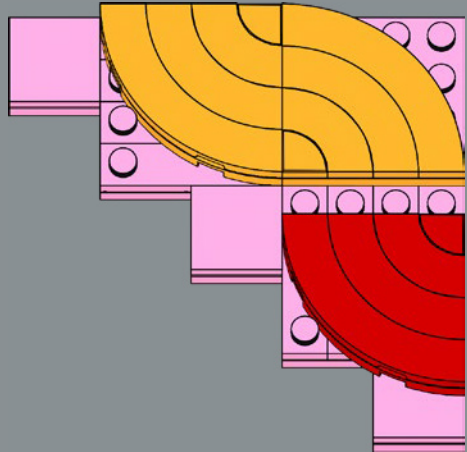

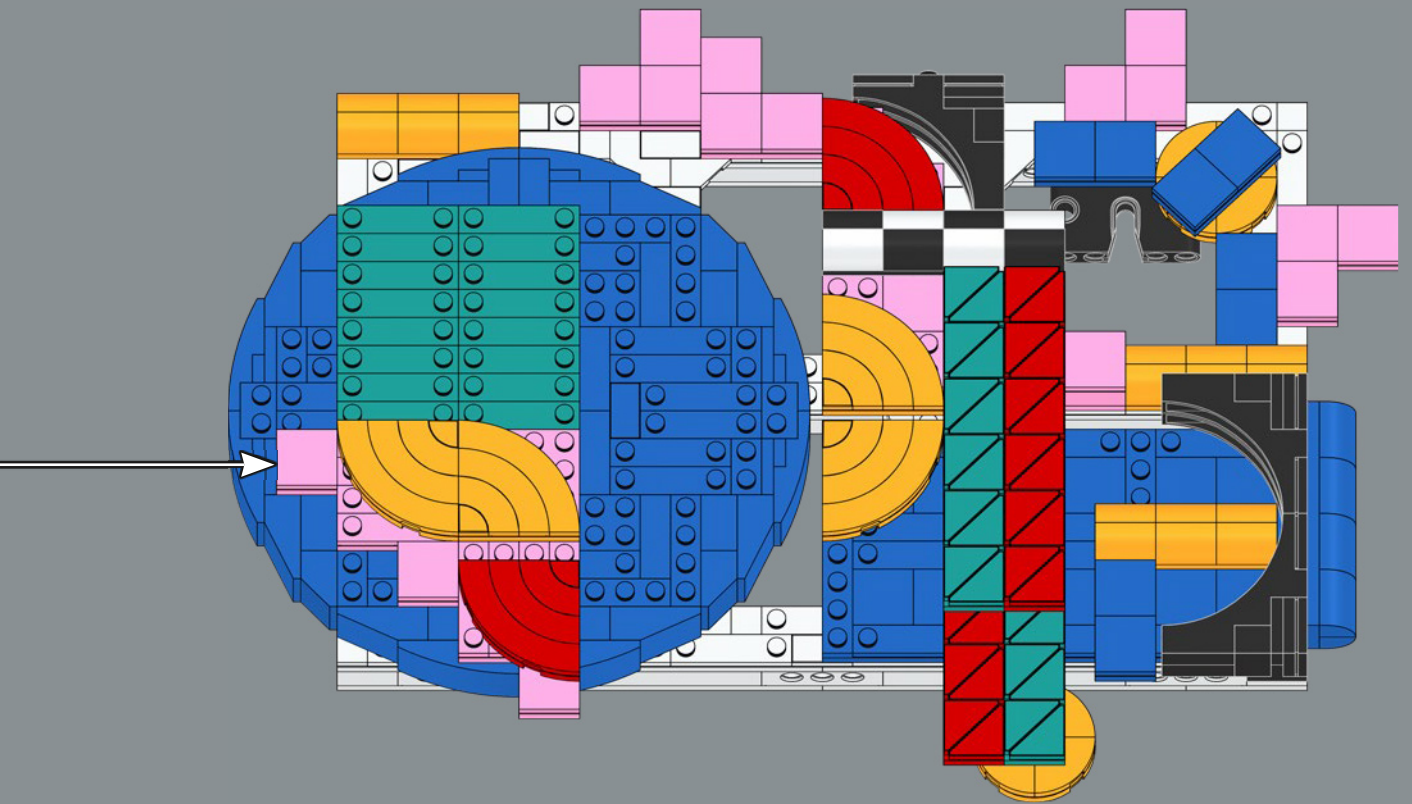

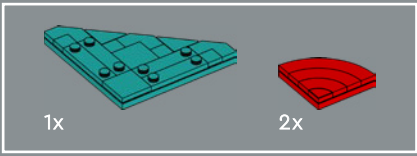

12

1

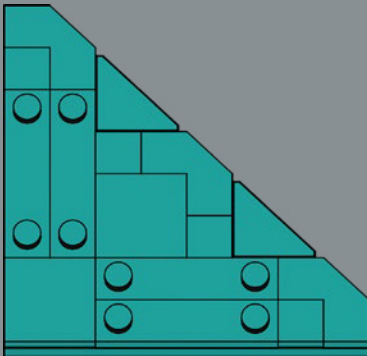

2

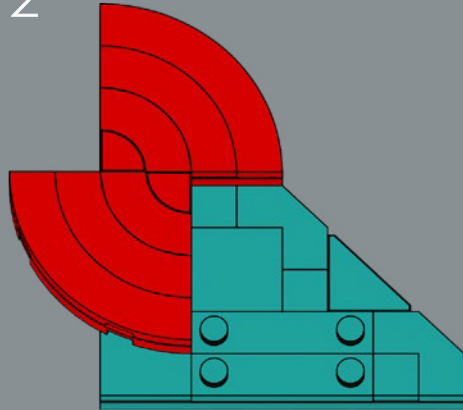

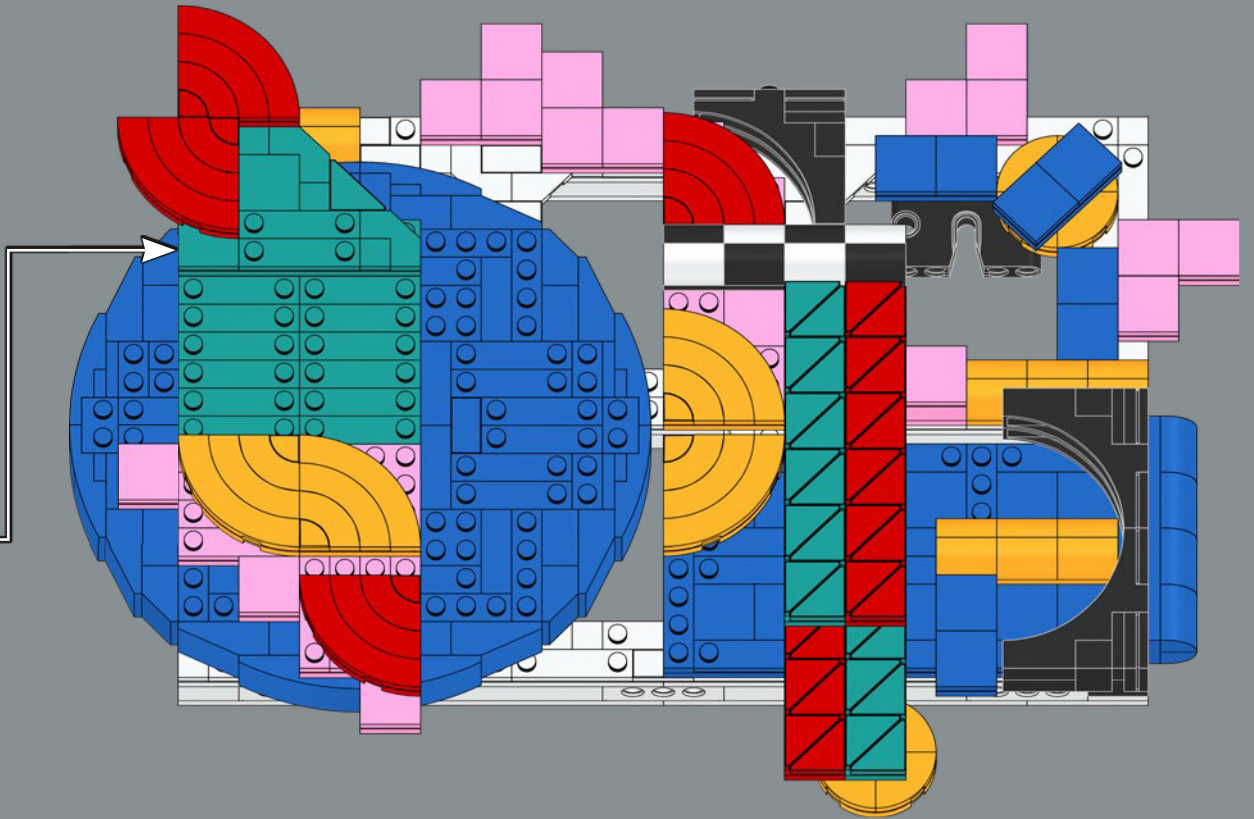

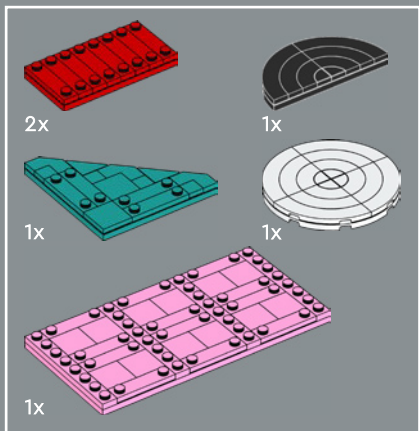

13

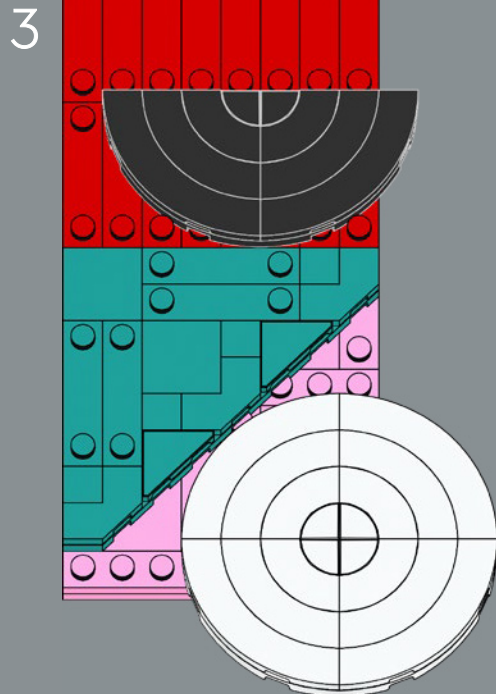
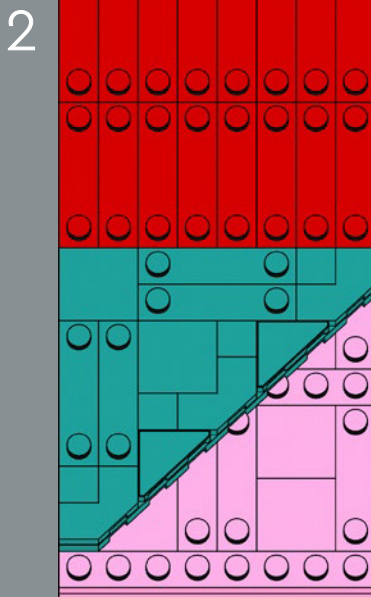
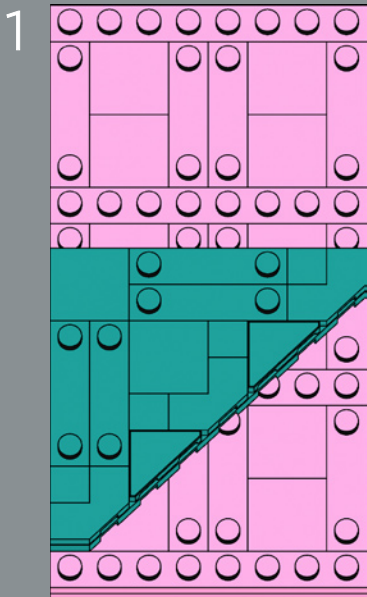

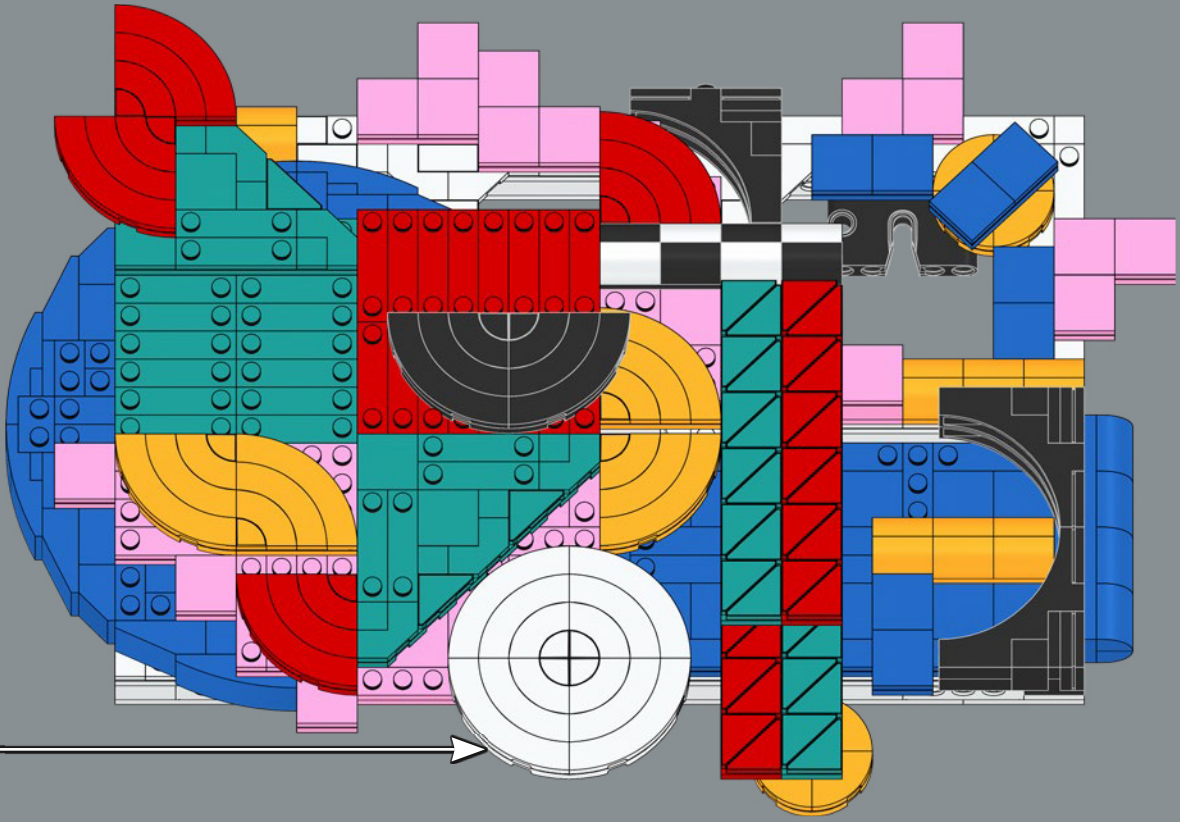



14

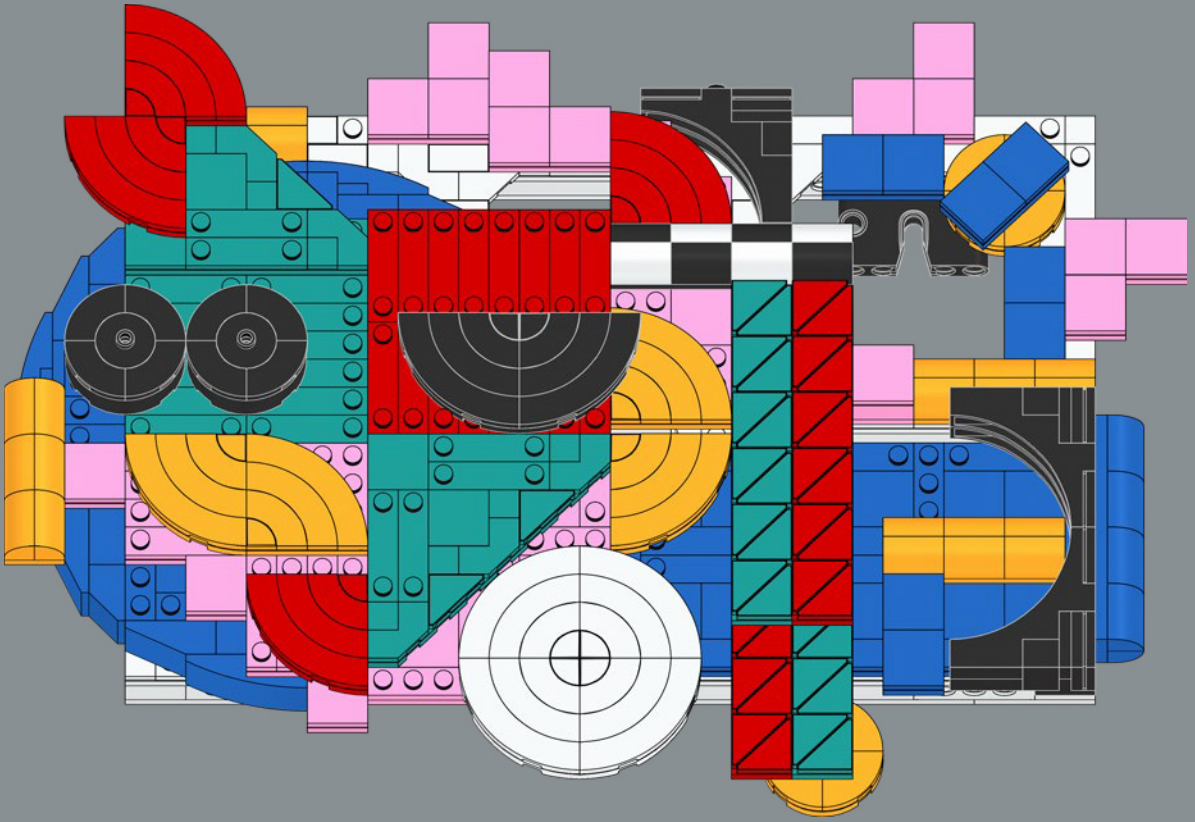

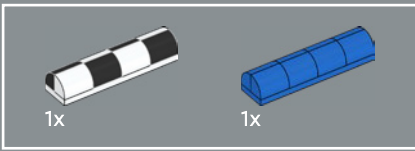

15

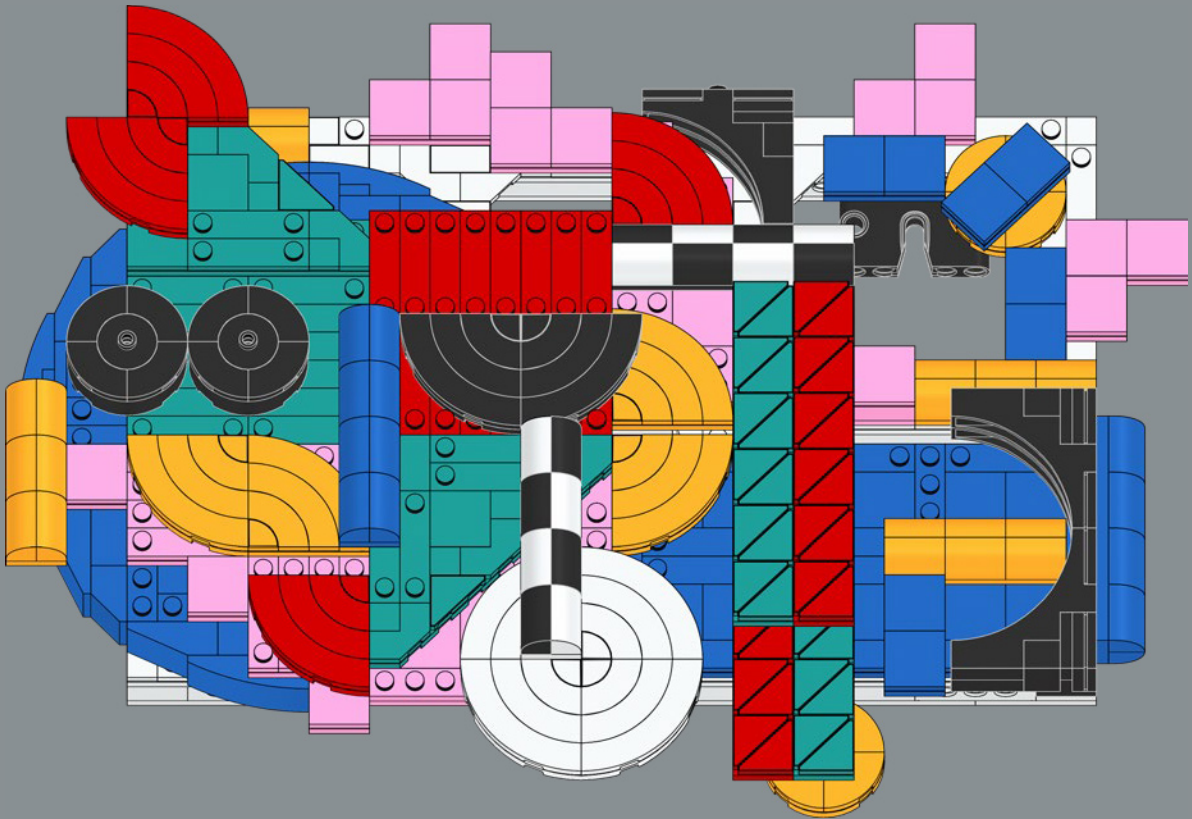

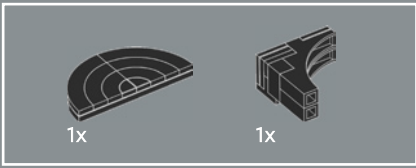

16

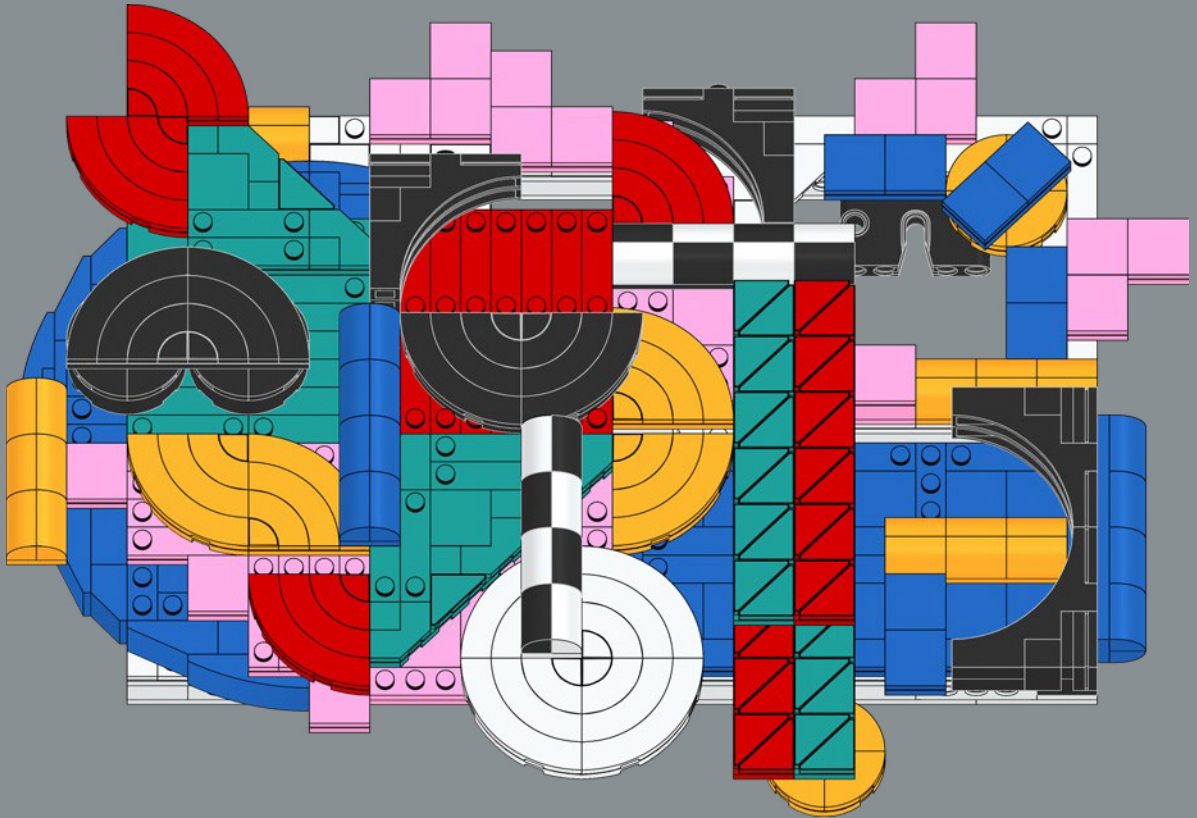

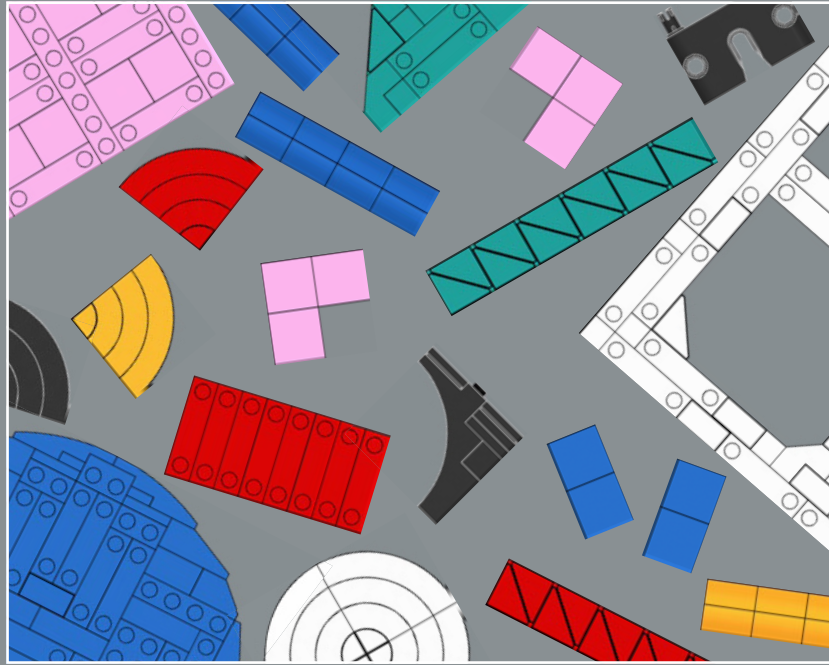

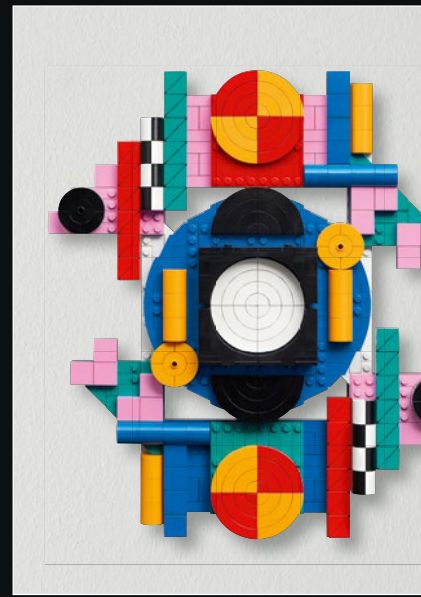
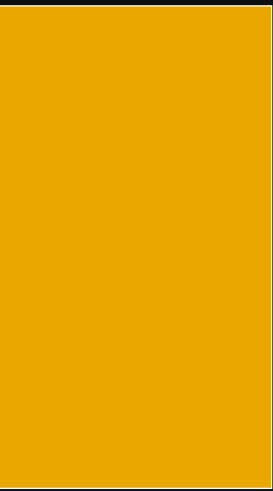
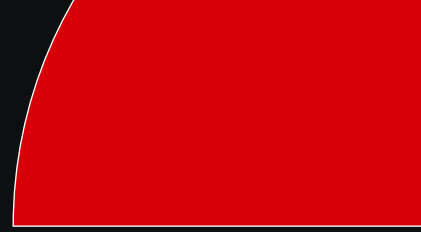

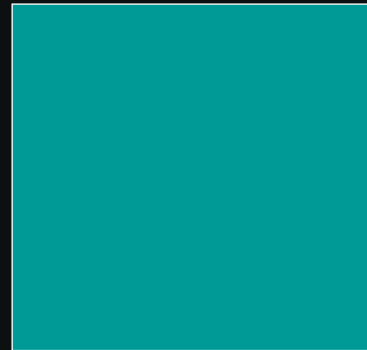
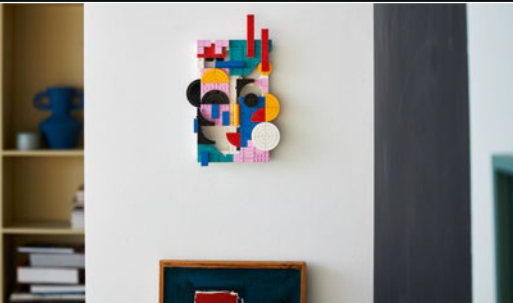



2x

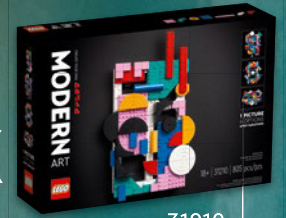

31210



EXPAND YOUR
MODERN ARTWORK
Combine 2 sets

DÉVELOPPEZ VOTRE
ŒUVRE D'ART MODERNE
Combinez 2 ensembles

AMPLÍA TU OBRA
DE ARTE MODERNO
Combina 2 sets



4x
300501
20x
307001
4x
6172366
6x
370001
22x
306901
8x
6248827
4x
6217875
4x
306801
4x
300301
4x
6172674
1x
235701
8x
6168612
56x
6249091
18x
370101
4x
6373439

1x
302001
8x
6350399
4x
6457244
8x
4178429
4x
6109817
2x
379501
10x
300801
2x
6138699
7x
6033776
1x
303401

1x
6331510
12x
244501
1x
4119227
4x
6036485
4x
6170390
24x
6351892
2x
300321
4x
6310198
6x
6061711
16x
6256923
4x
6375825

4x
6458177
4x
6297811
4x
4181138
2x
303521
2x
4255035
8x
302323
4x
6189191
2x
306923
16x
6290532
2x
6117968
20x
306823
4x
303923

8x
300323
4x
302223
12x
4587840
8x
6294307
8x
4212411
32x
6292291
8x
6429287
4x
302023
1x
4560180
4x
346023
4x
303423
1x
4610354

1x
300124
6x
4567996
4x
614126
4x
6172383
6x
6279875
2x
6195325
8x
6275732
4x
302326
4x
300426
4x
6250020
12x
6191630

8x
302328

24x
6250120

8x
302226

1x
4286050

4x
6214457

4x
379528

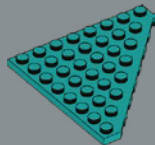

8x
306826

4x
4517993

2x
6133933

6x
4211795

2x
6430060

2x
4558957

32x
4615728

24x
6334836

8x
6213782

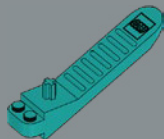

4x
6434275

4x
4550359

12x
6334203

28x
6334128

4x
6254100

8x
6075062

28x
6253655

2x
6115115

4x
6273853

2x
6453950

8x
4520632

4x
4520632

4x
6453948

6x
6453949

2x
6302094

14x
6453947

4x
6458166



2x
6133200

4x
6143789

4x
6453946

1x
303426

2x
6358030

4x
6097509

2x
303026

1x
6453953

 [LEGO.com/service](https://www.LEGO.com/service)



YOU COULD WIN

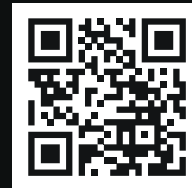

YOU COULD WIN

Your feedback will help shape the future development of this product series.

Visit:

DU KÖNNTEST GEWINNEN

Dein Feedback trägt zur Weiterentwicklung dieser Produktreihe bei.

Geh auf:

VOUS POURRIEZ GAGNER

Vos commentaires nous aideront à concevoir les futurs produits de cette gamme.

Visitez :

POTRESTI VINCERE TU

La tua opinione ci aiuterà a migliorare la creazione futura di questa linea di prodotti.

Visita:

PUEDES GANAR

Tu opinión contribuirá al futuro de esta serie de productos.

Visita:

轻松获奖

您的反馈将有助于我们在今后改进本产品系列。

请访问：

LEGO.com/productfeedback

You also have the chance to win a LEGO® set.

Terms and conditions apply.*

Außerdem hast du die Chance, ein LEGO® Set zu gewinnen.

Es gelten die Teilnahmebedingungen.*

Vous pourriez également gagner un ensemble LEGO®.

Des conditions s'appliquent.*

Hai anche la possibilità di vincere un set LEGO®.

Termini e condizioni sono applicabili.*

También tienes la oportunidad de ganar un set LEGO®.

Aplican términos y condiciones.*

您还有机会赢取乐高®套装。

条款和条件适用。*

*LEGO.com/productfeedback-terms

