



# IDEAS

Cosmic Cardboard  
ADVENTURES

40533



LEGO.com



## Meet LEGO® Ideas fan designer Ivan Guerrero

As kids, playing with LEGO® bricks and cardboard boxes let us journey to the frontiers of our imagination. My siblings and I had a lot of fun discovering new boxes to play with. It is a universal childhood experience, I think.

This set was inspired by my own childhood memories of building things with cardboard boxes – from trains and dioramas to robots and spaceships.



Sharing my memories with the LEGO team and being part of the design process made this experience unique and special, almost like sharing an old family album with everyone who builds this set.

From a very early age, I loved imaginative play with LEGO® bricks and discovering new ways to express my ideas. Every time I build, I learn something new. Just like an empty cardboard box, LEGO bricks come with infinite potential. Just add your own fun and imagination. It is no wonder that both LEGO bricks and cardboard boxes are recognized by the National Toy Hall of Fame® for their endless adaptability for creative play.

I believe it is important to maintain a sense of 'playful curiosity' in anything you do. Ask questions, search for unexpected answers, tinker and take things apart, build things you love, test your ideas, and always approach

things with a sense of fun. I think these are invaluable skills for building successful LEGO Ideas submissions.

*Ivan Guerrero, LEGO® Ideas double competition winner and LEGO enthusiast*





## Rencontre avec le concepteur LEGO® Ideas amateur Ivan Guerrero

Quand nous étions enfants, jouer avec des briques LEGO® et des boîtes en carton nous permettait d'explorer les frontières de notre imagination. Ma fratrie et moi adorions trouver de nouvelles boîtes avec lesquelles jouer. Je crois que tout le monde a vécu cette expérience dans son enfance. Cet ensemble est inspiré de mes souvenirs d'enfance, de l'époque où je construisais des objets avec des boîtes en carton, qu'il s'agisse de trains, de dioramas, de robots ou de vaisseaux spatiaux. Partager mes souvenirs avec l'équipe LEGO et faire partie



du processus de conception a rendu cette expérience unique et spéciale, un peu comme si je partageais un vieil album de photos de famille avec tous ceux qui construisent cet ensemble. Dès mon plus jeune âge, j'adorais jouer avec des briques LEGO et découvrir

de nouvelles façons d'exprimer mes idées. Chaque construction m'apprend quelque chose de nouveau. Tout comme une boîte en carton vide, les briques LEGO® ont un potentiel infini. Il suffit d'ajouter une pincée d'imagination. Il n'est pas surprenant que les briques LEGO et les boîtes en carton soient reconnues par le National Toy Hall of Fame® (le temple de la renommée des jouets), pour leur éternelle adaptabilité au jeu créatif. Je crois qu'il est important de conserver une « curiosité ludique » dans tout ce que nous entreprenons. Posez des questions, cherchez des réponses surprenantes, bricolez et démontez des objets, construisez des objets que vous aimez, testez vos idées et abordez toujours les choses avec

enthousiasme. Je pense que ce sont des compétences inestimables pour soumettre des constructions LEGO Ideas réussies.

*Ivan Guerrero, gagnant du concours d'amateurs de LEGO® Ideas et passionné de LEGO*





## Conoce al fan diseñador de LEGO® Ideas: Ivan Guerrero

Cuando somos pequeños, jugar con cajas de cartón y bricks LEGO® nos permite viajar hasta las fronteras de nuestra imaginación. Mis hermanos y yo nos la pasábamos genial descubriendo nuevas cajas con las que inventar juegos. Debe de ser universal: creo que todos lo hicimos en nuestra niñez. Este set se inspira en mis propios recuerdos de infancia, en aquellos momentos en los que construía cosas con cajas de cartón, desde trenes y dioramas hasta robots y naves espaciales. Compartir todo lo que se me venía a la memoria con el equipo de



LEGO y formar parte del proceso de diseño se convirtió en una experiencia única y especial, casi como enseñar un viejo álbum familiar a todo el que construya este set.

Ya con muy poquitos años, me encantaba jugar con bricks LEGO, usar

mi imaginación y descubrir nuevas maneras de expresar mis ideas. Cada vez que construyo aprendo algo nuevo. Exactamente igual que una caja de cartón vacía, los bricks LEGO® traen de serie un potencial infinito. Solo tienes que aportar tu imaginación y tus ganas de divertirse. A nadie sorprende, por tanto, que los bricks LEGO y las cajas de cartón tengan su merecido lugar en el Salón Nacional de la Fama del Juguete estadounidense por su inagotable adaptabilidad para el juego creativo. Opino que es importante mantener un cierto sentido de "curiosidad lúdica" en todo lo que hagas. Preguntar, buscar respuestas inesperadas, desarmar objetos, hacerles pequeños ajustes, construir aquello que adoras, poner a prueba tus ideas y siempre enfocar

cualquier cosa con una actitud divertida. Creo que, en conjunto, son habilidades de valor incalculable a la hora de crear propuestas para LEGO Ideas que logren triunfar.

*Ivan Guerrero, ganador de dos concursos de LEGO® Ideas y entusiasta de LEGO*





Les aventures du vaisseau  
**USS EN CARTON**

**AVENTURAS**  
del Cosmic Cardboard



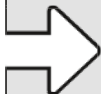
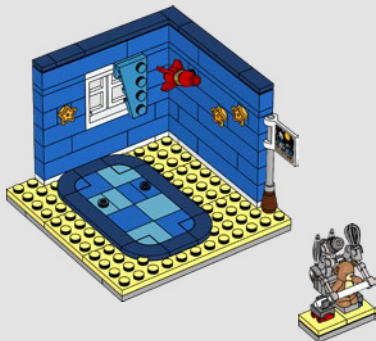
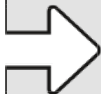

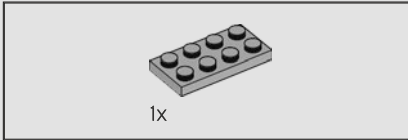
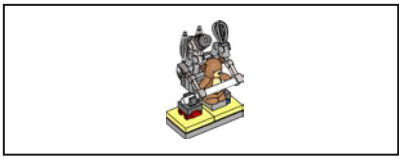

1

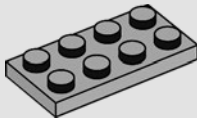

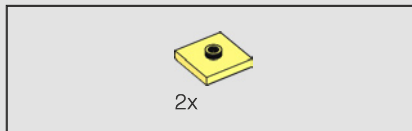

2

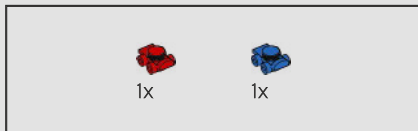
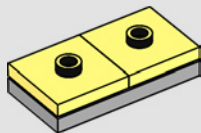

3

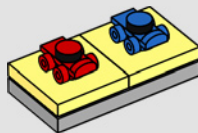



4

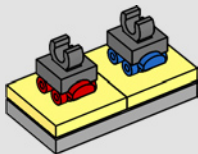

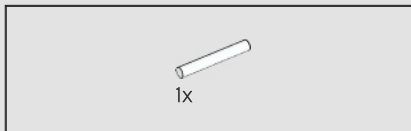

5

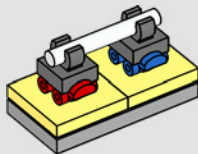

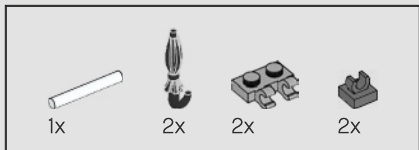

6

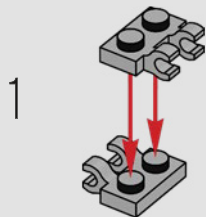

2

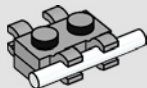

3

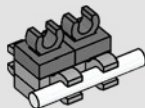



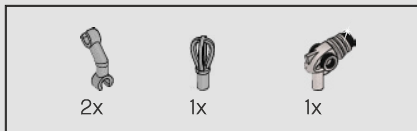

7

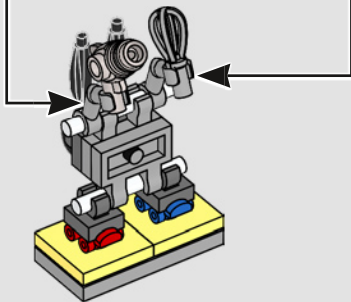
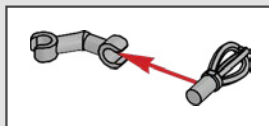
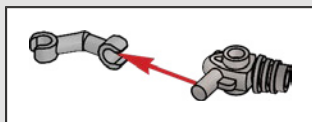





8

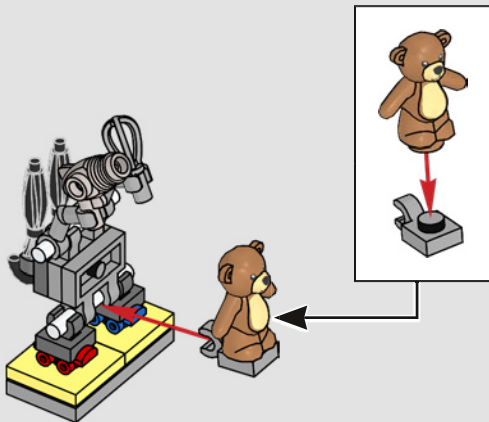

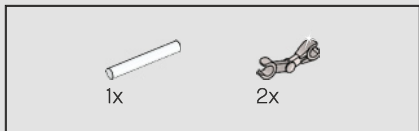

9

1



2

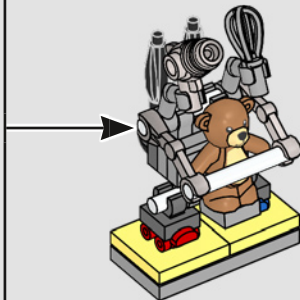
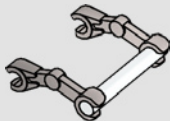

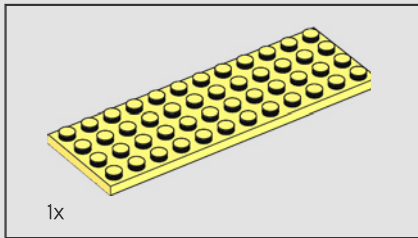
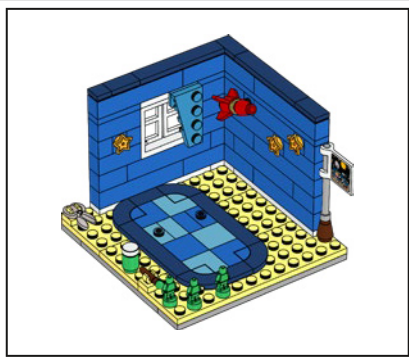

1

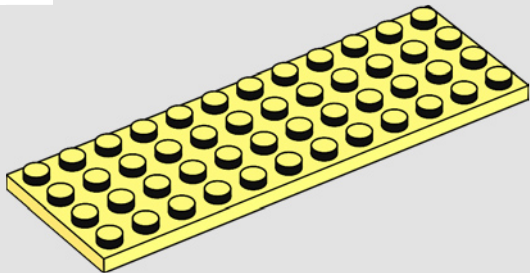

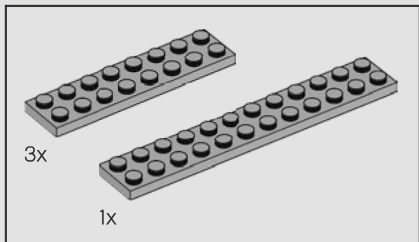

2

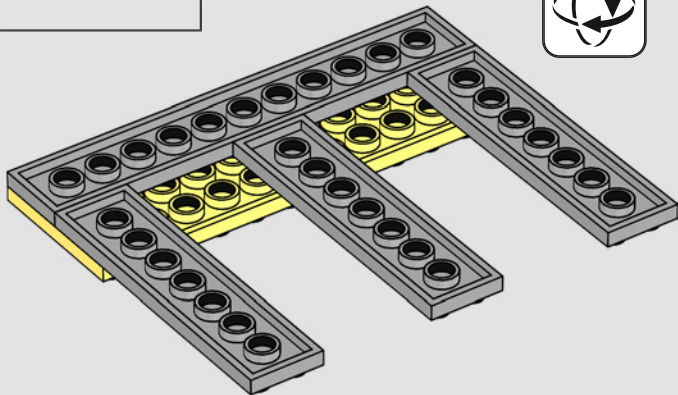

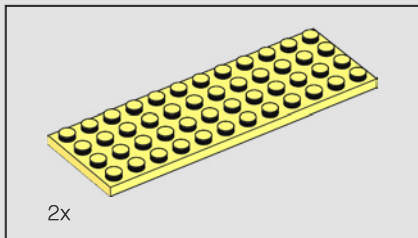

3

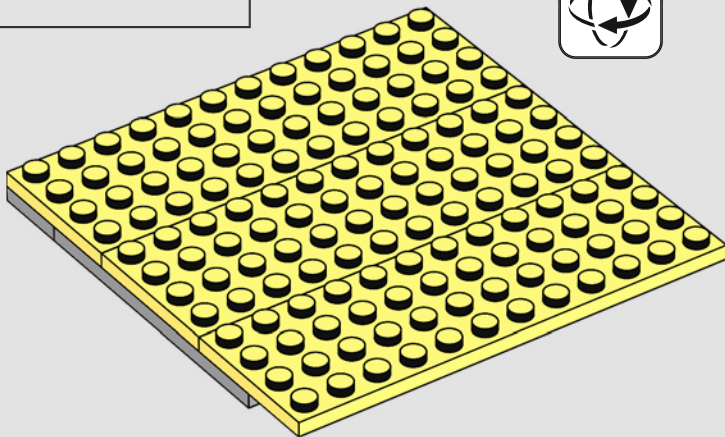

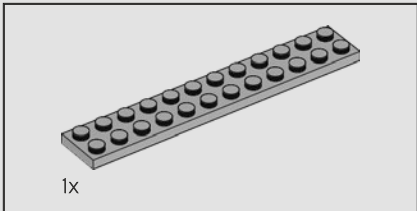

4

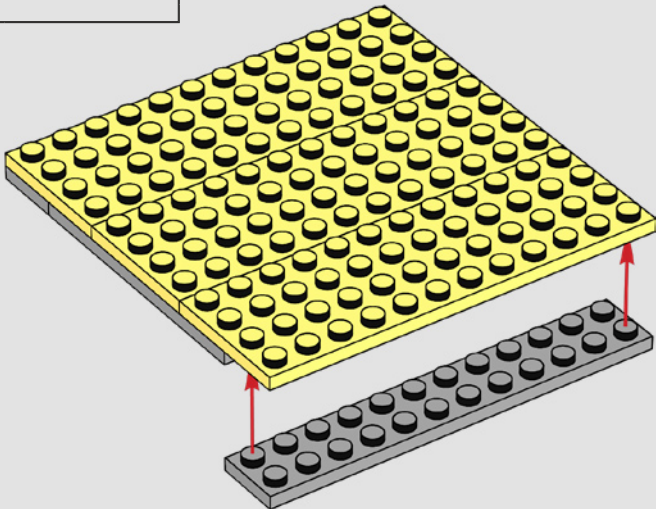

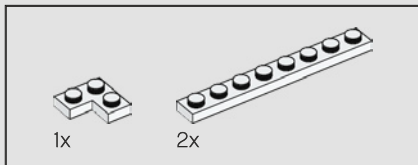

5

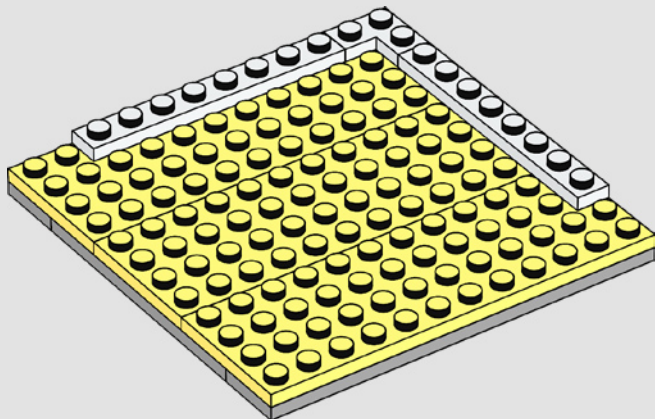



6

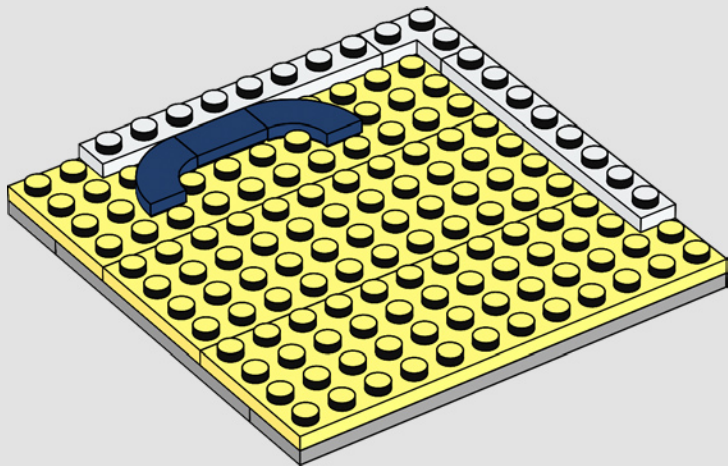



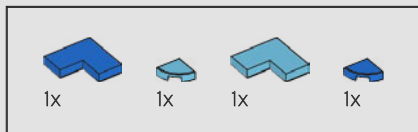

7

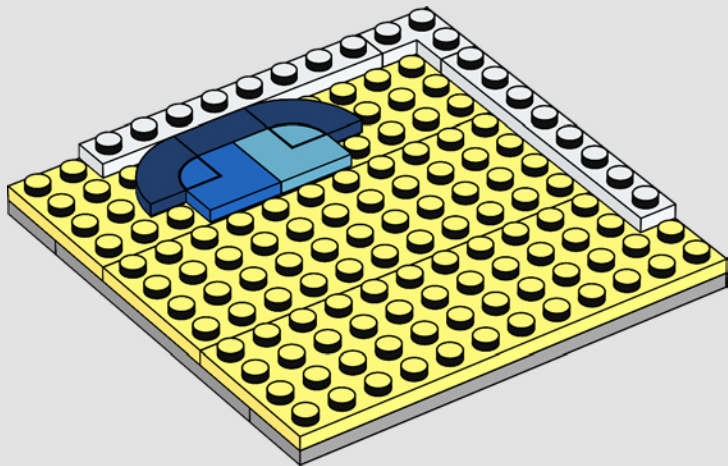

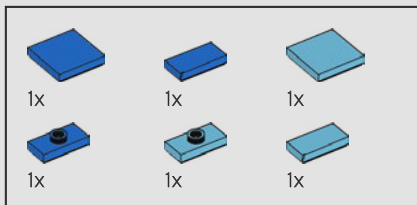

8

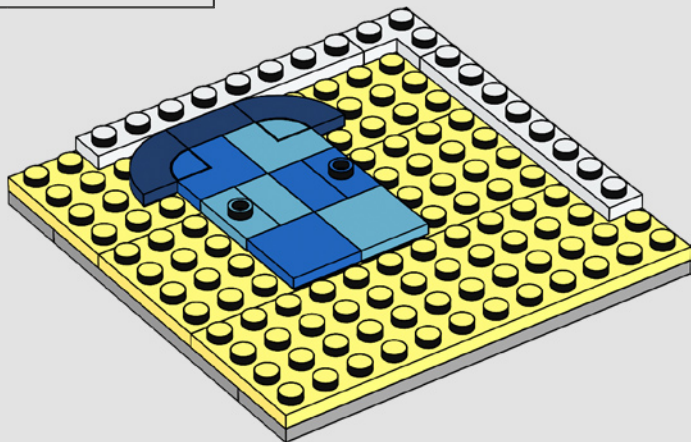

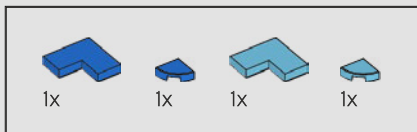

9

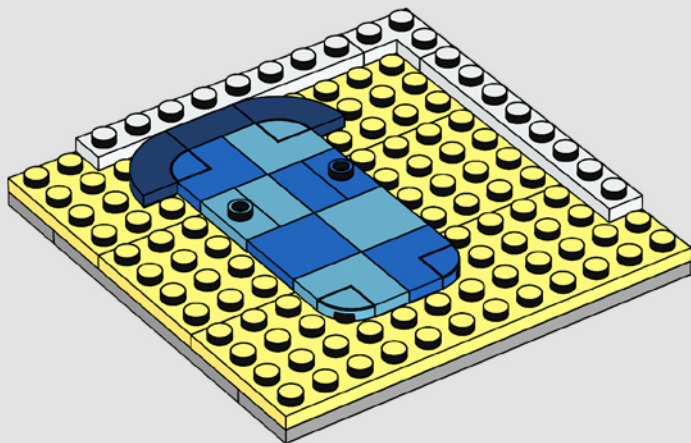

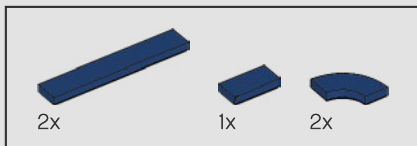

10

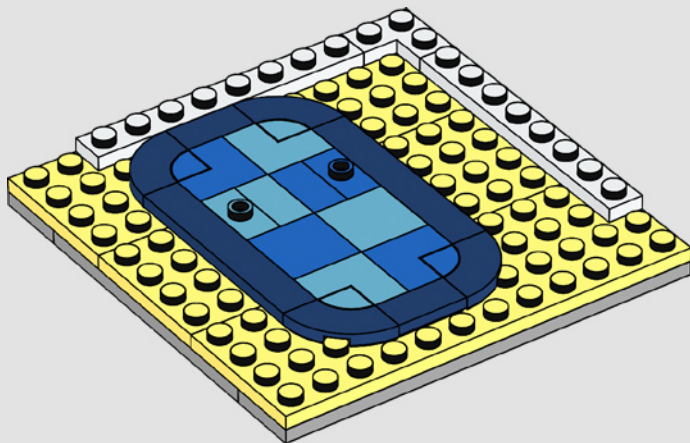

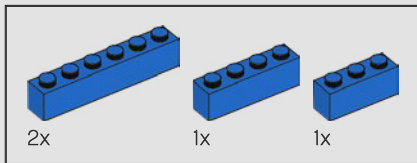

11

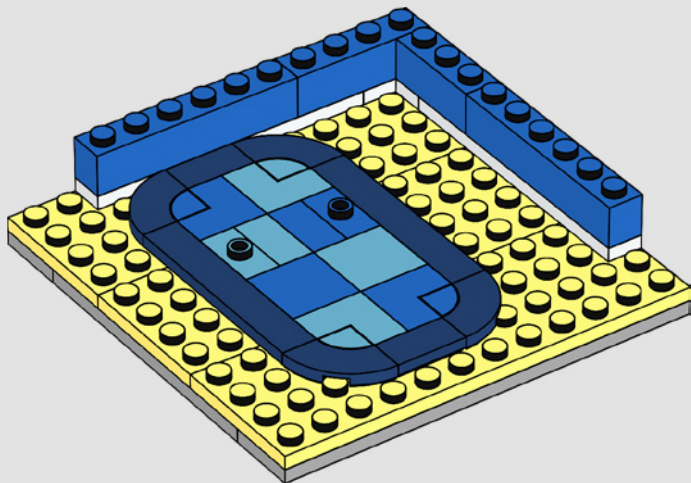

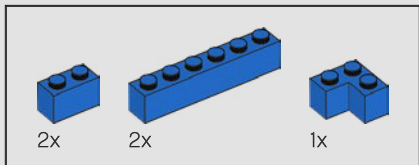

12

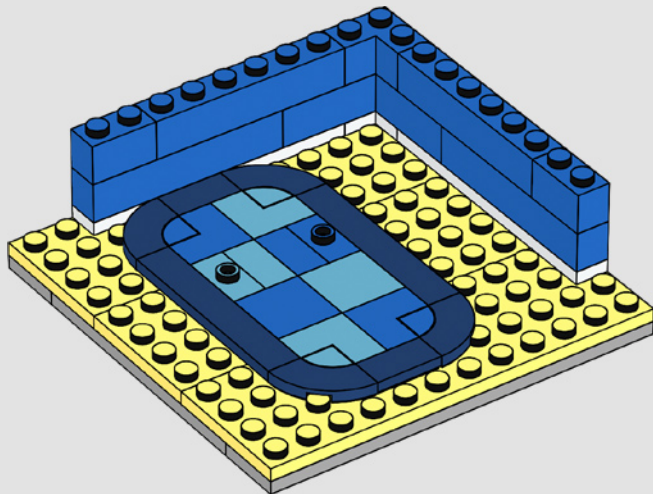

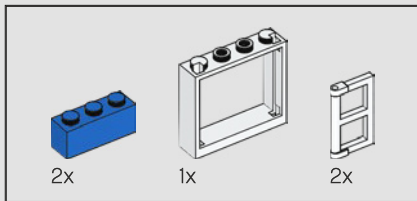

13

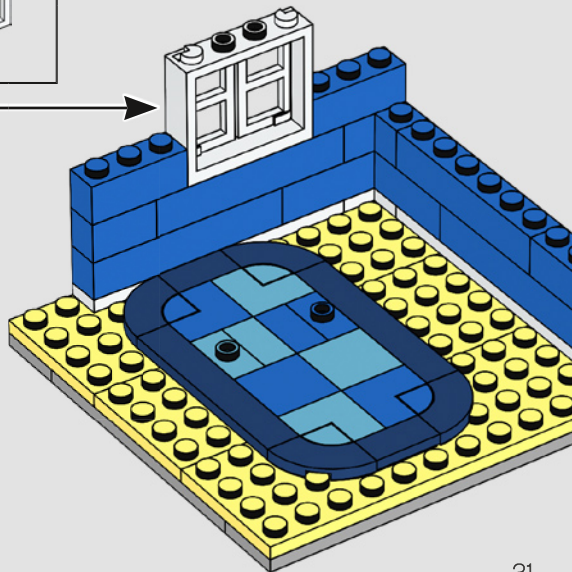
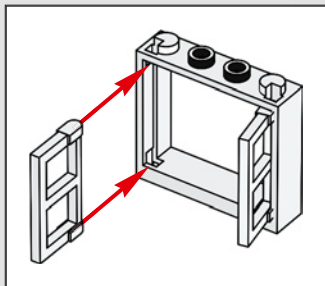

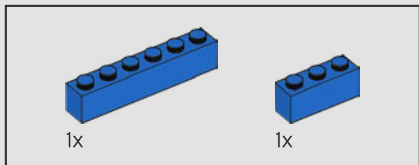

14

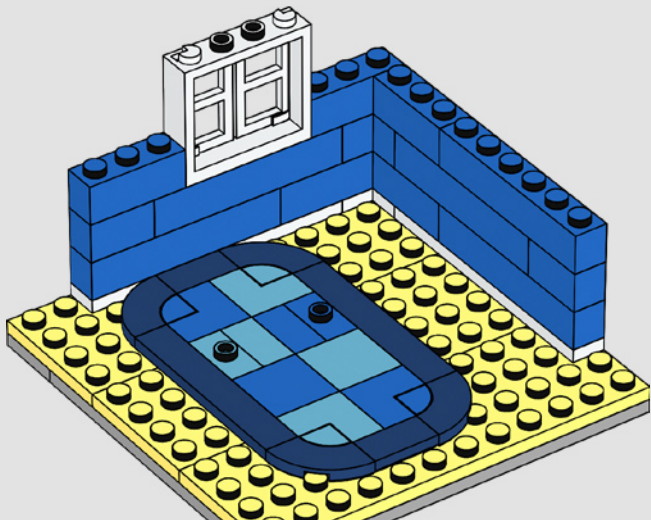



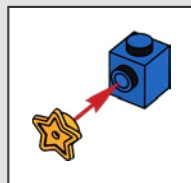
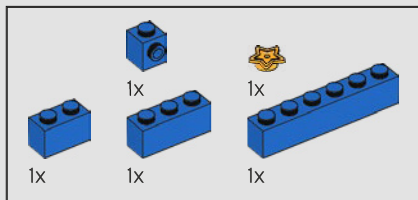

15

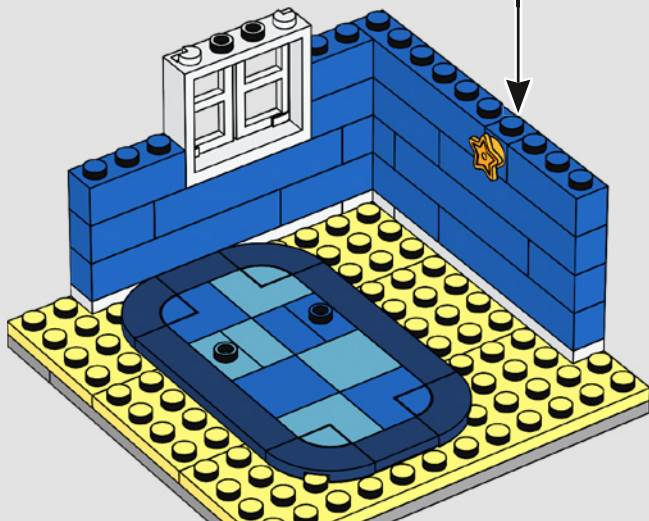

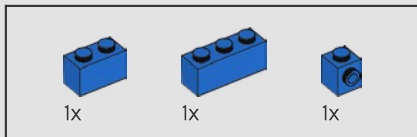

16

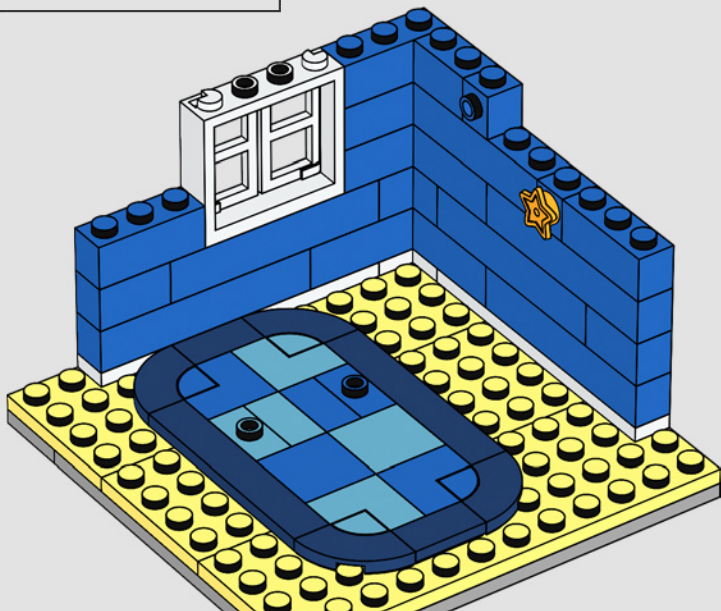



17

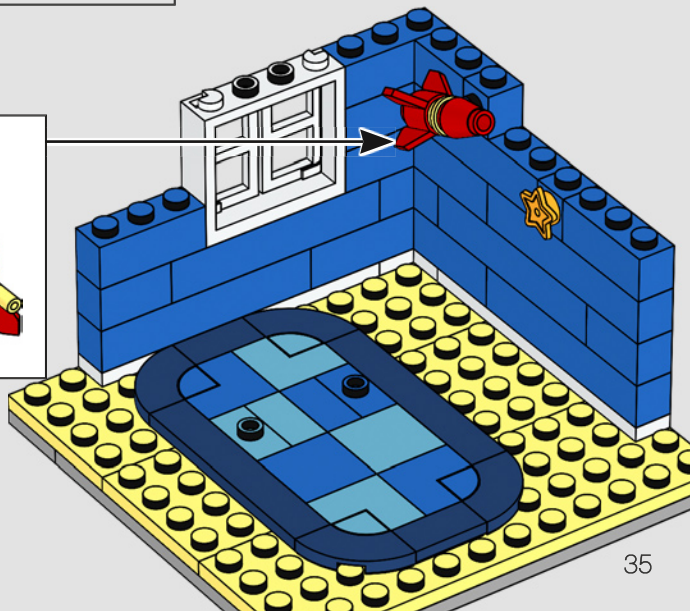
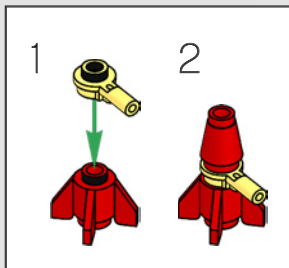

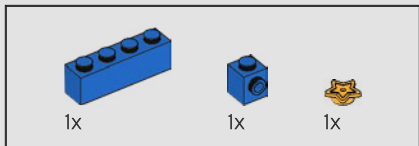

18

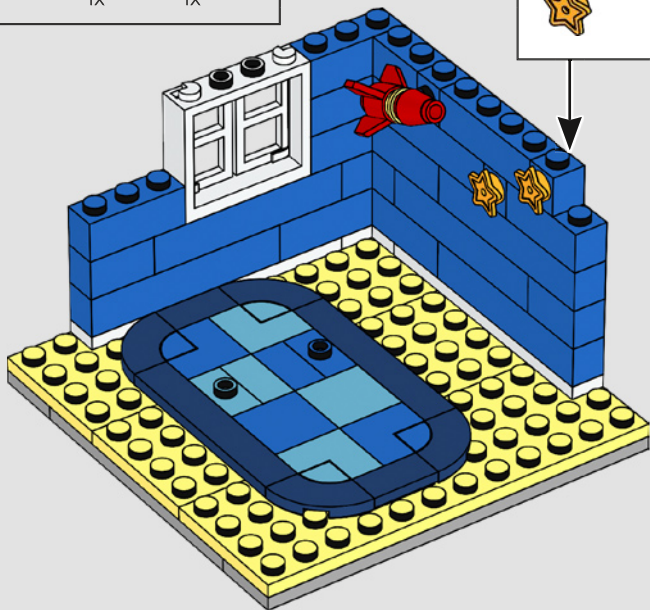
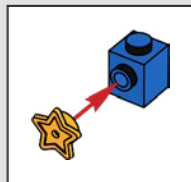

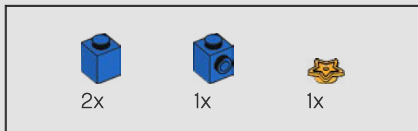

19

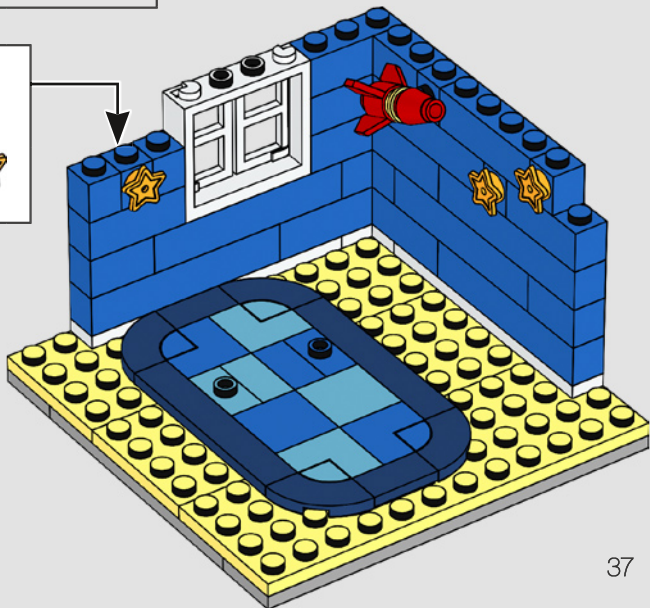
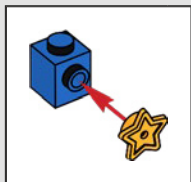

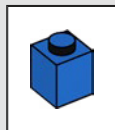
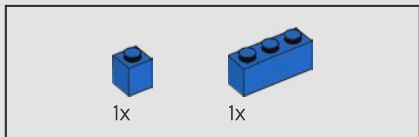

20

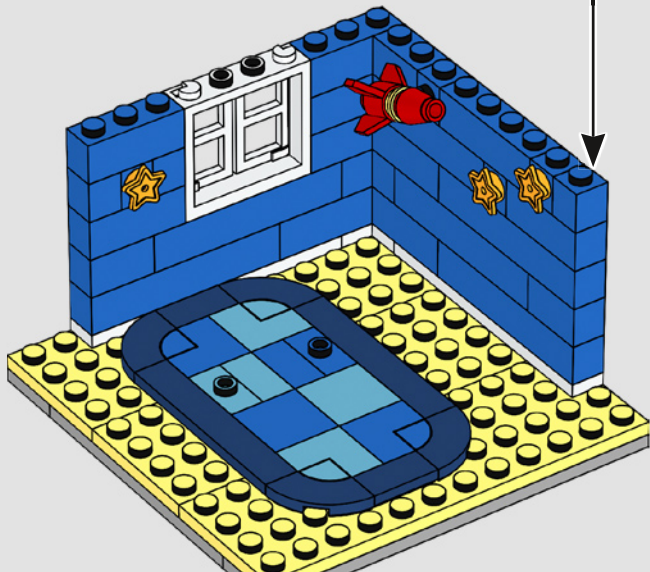

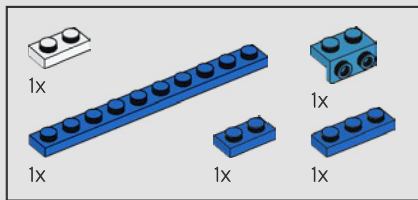

21



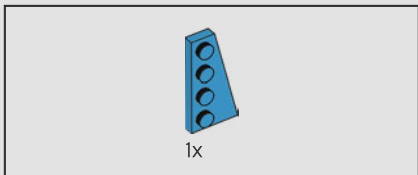

22

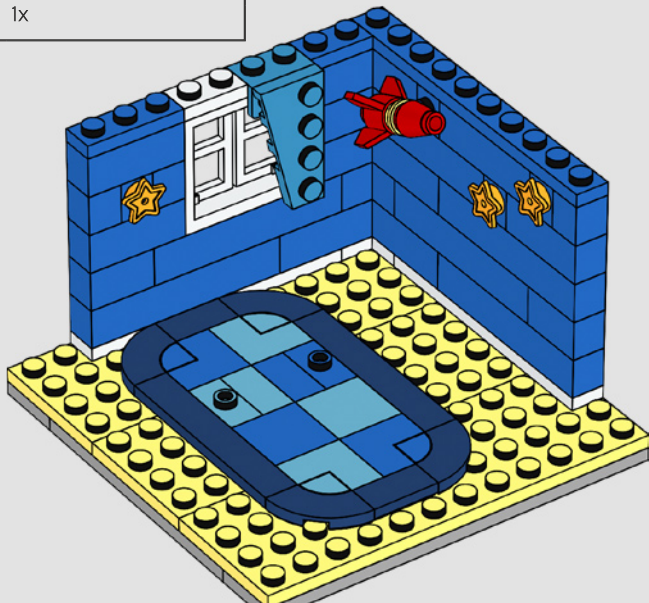



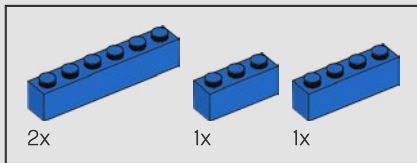

23

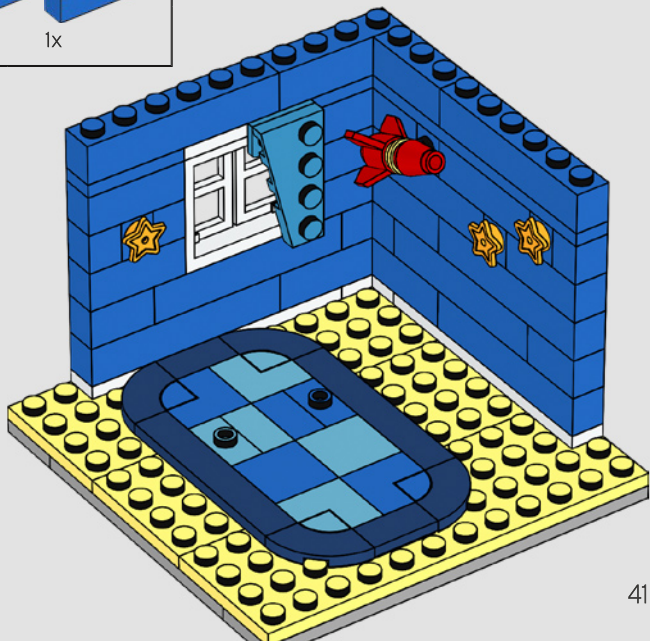

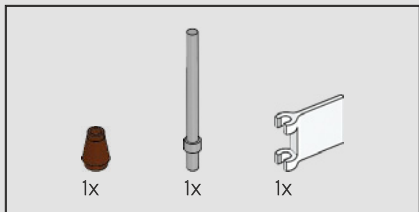

24

1



2

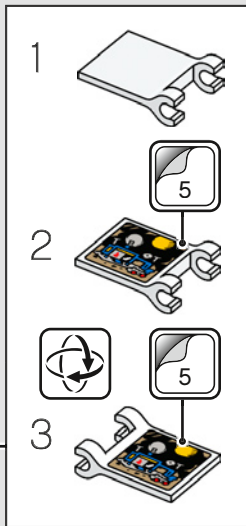
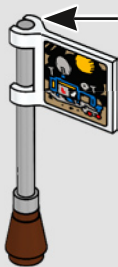

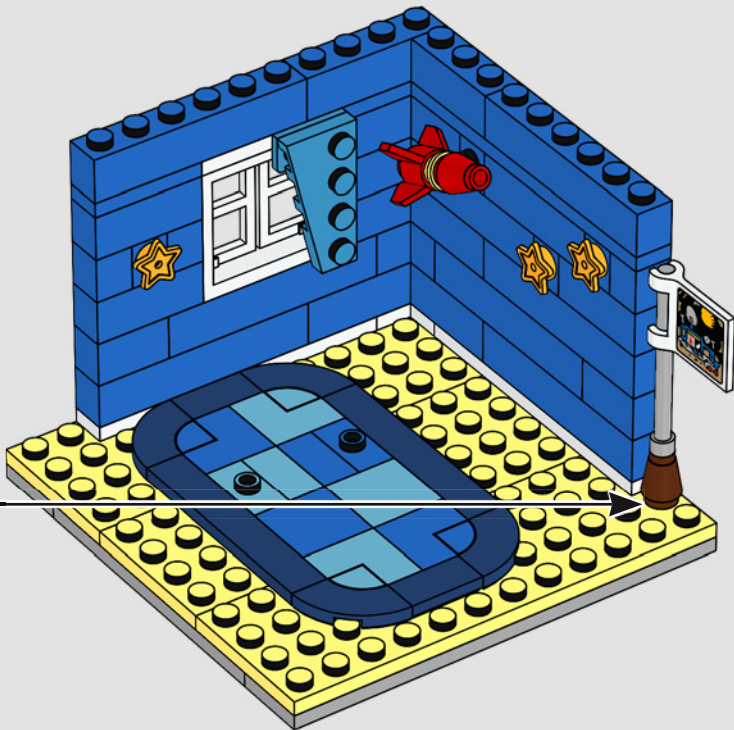

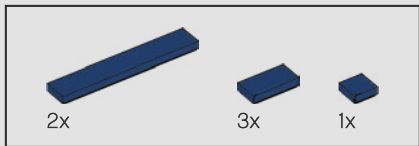



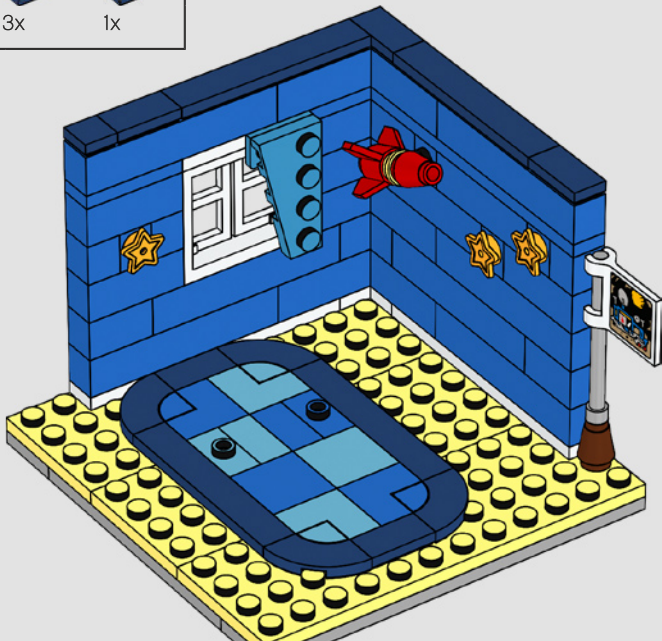

25

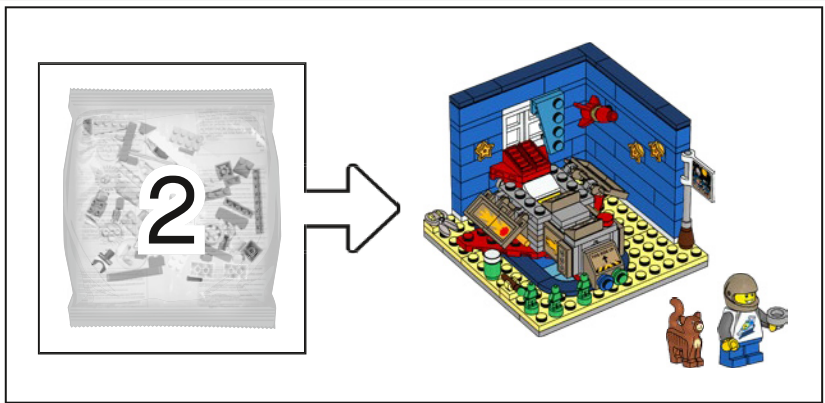

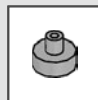
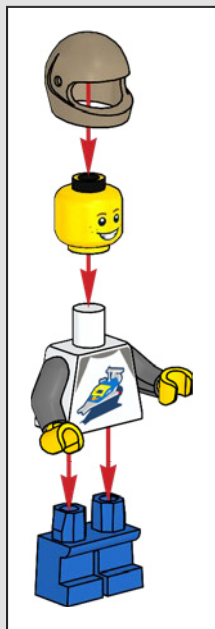
44





-   
1x
-   
1x
-   
1x
-   
1x

26

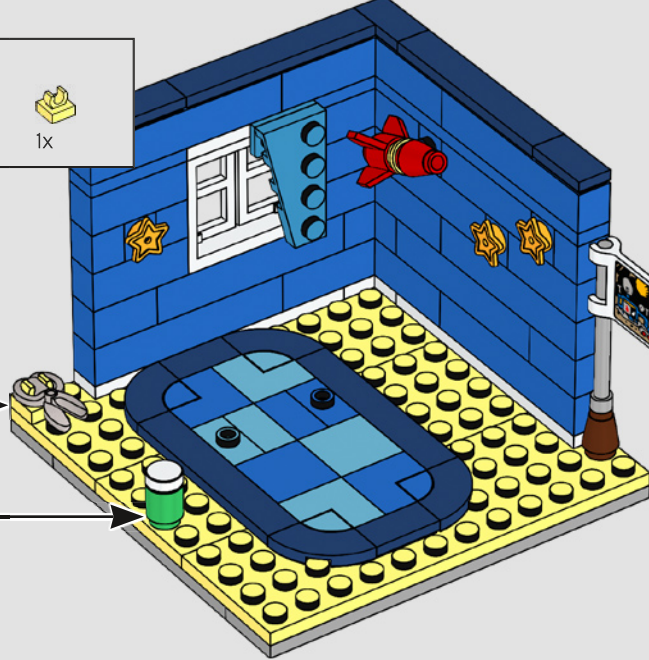
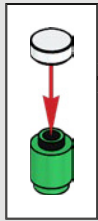
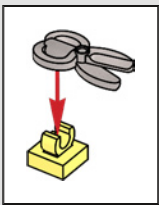

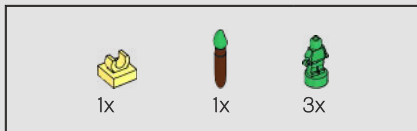

27

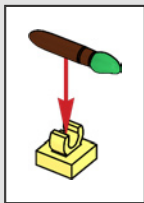



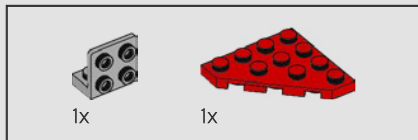
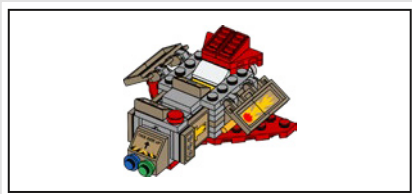

1

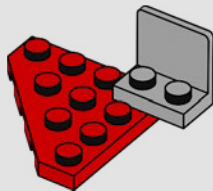



2

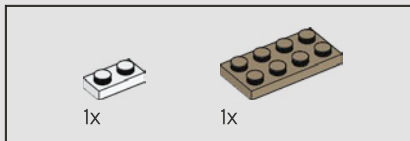
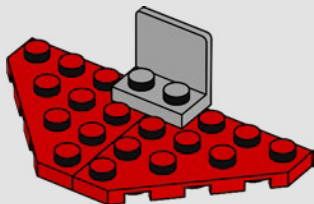

3

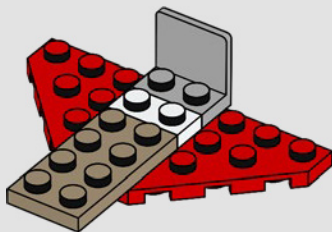

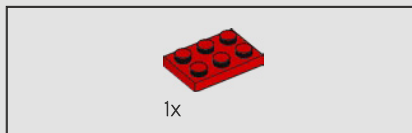

4

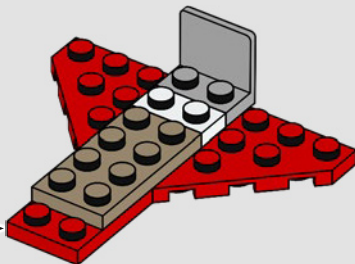
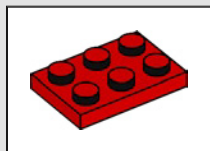

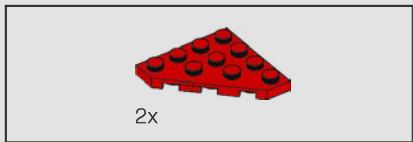

5

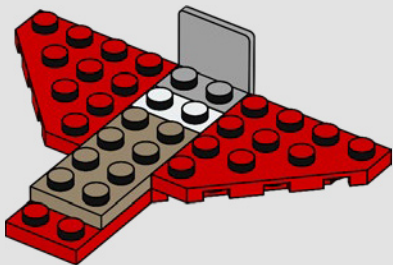

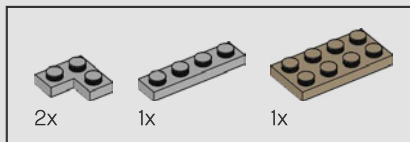

6

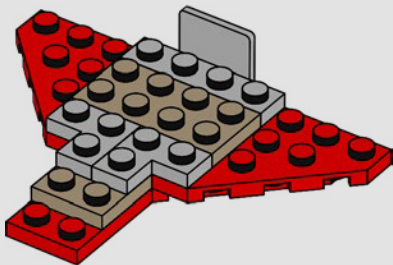

7

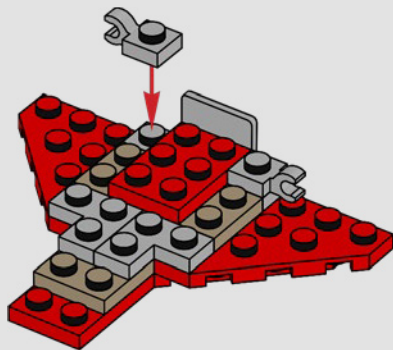

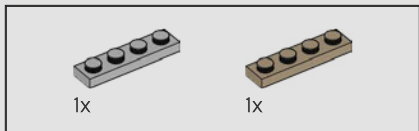

8

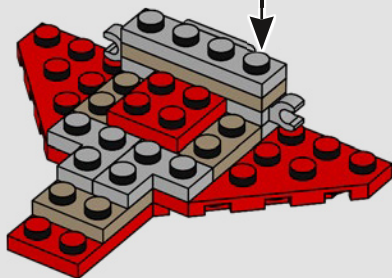
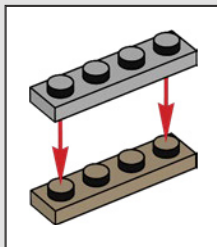

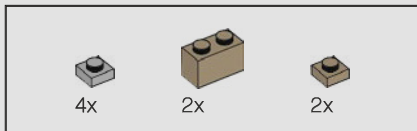

9

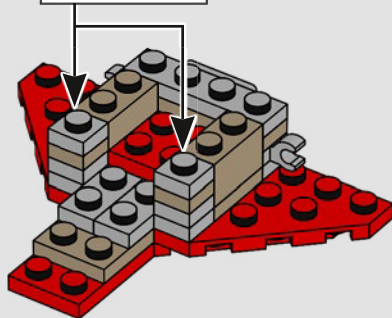
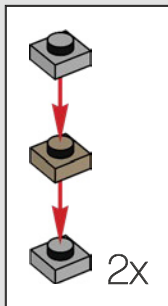

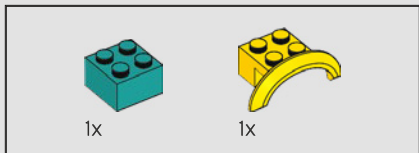

10

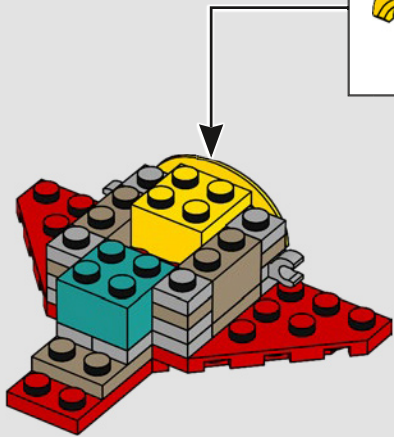
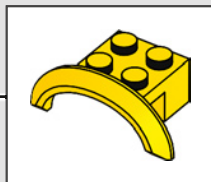



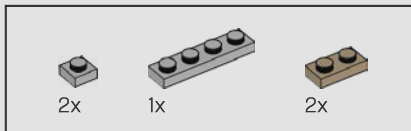

11

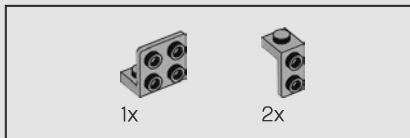
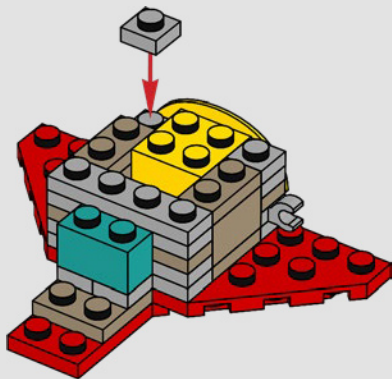

12

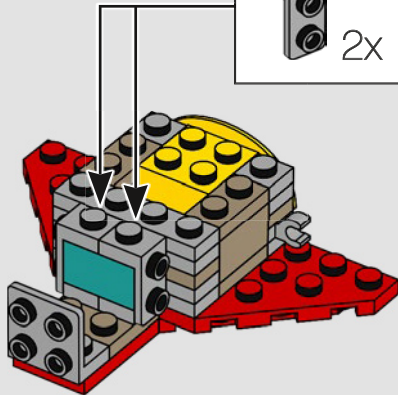
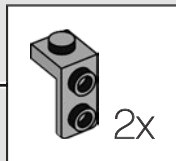

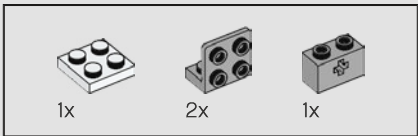
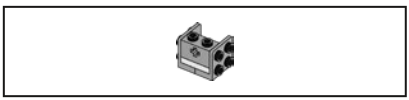

13

1



2

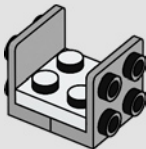

3

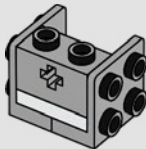

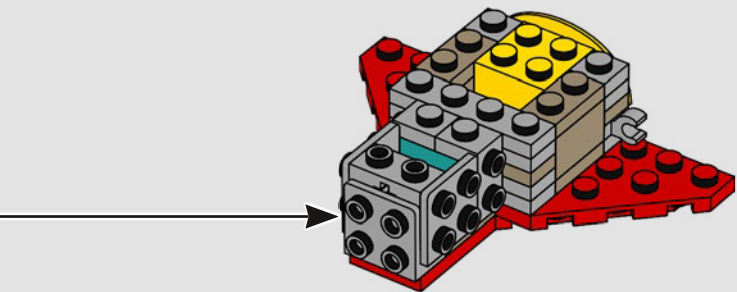

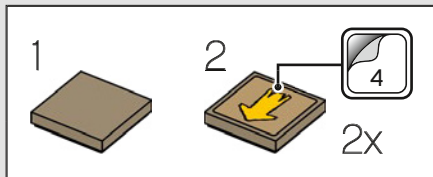
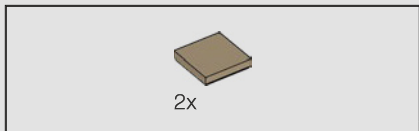

14

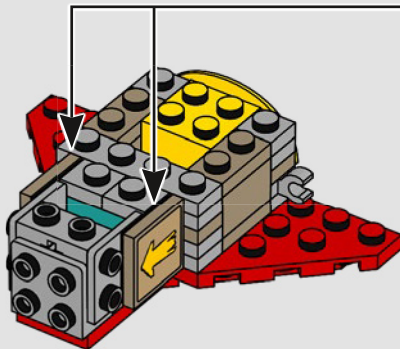

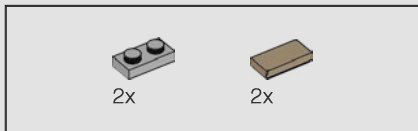

15

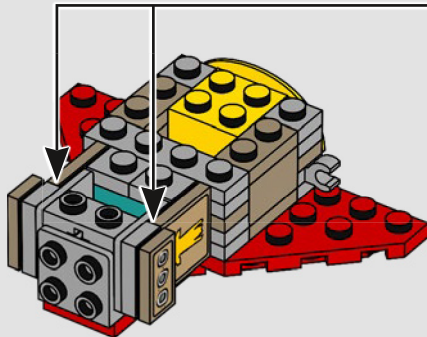
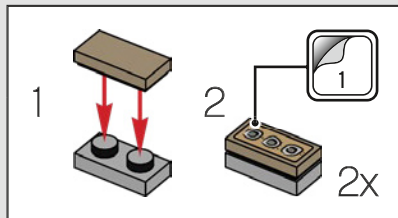

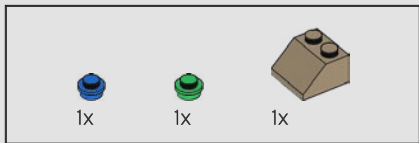

16

1

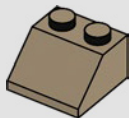

2

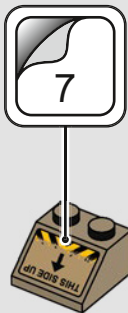

3



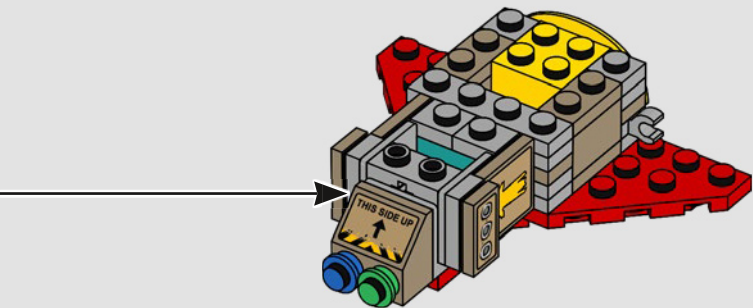

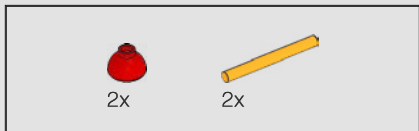

17

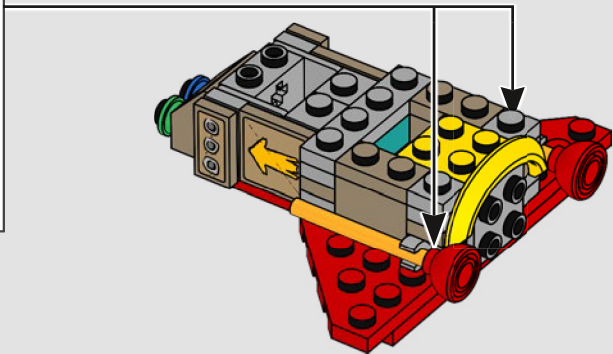
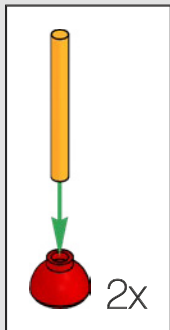



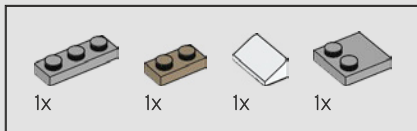

18

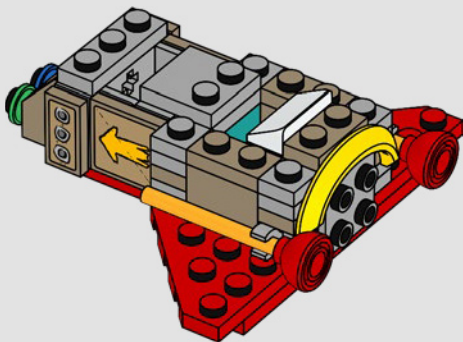

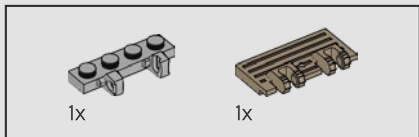

19

1

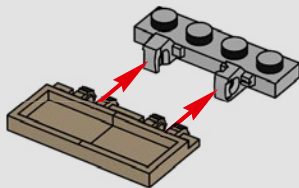

2

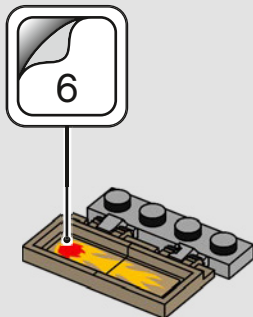

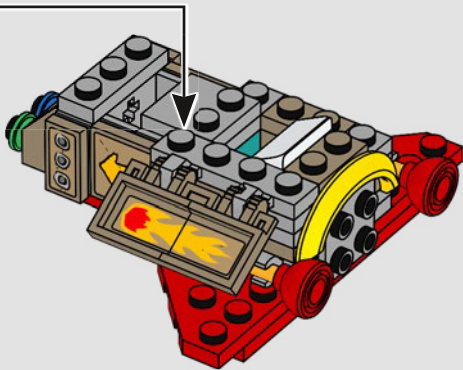

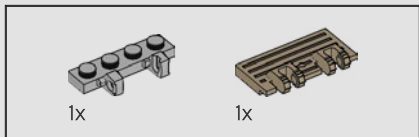

20

1

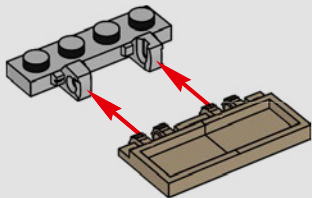

2

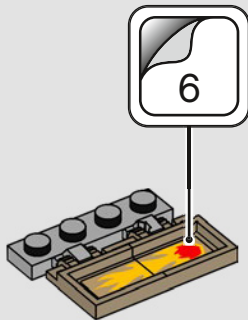

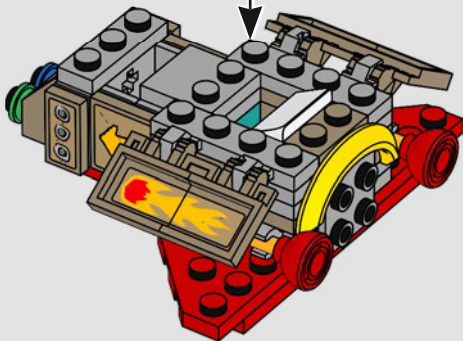



21

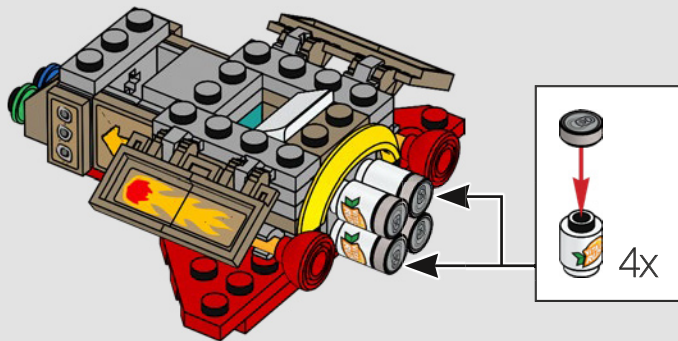

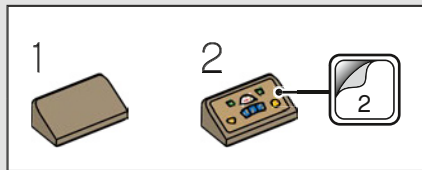
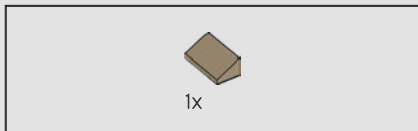

22

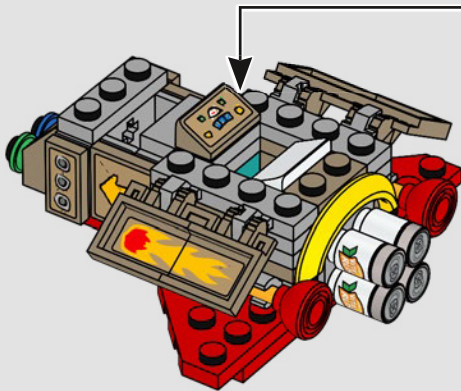

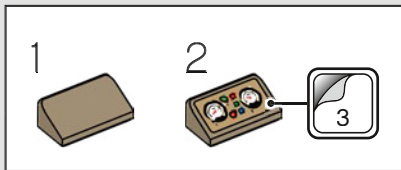
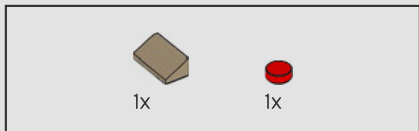

23

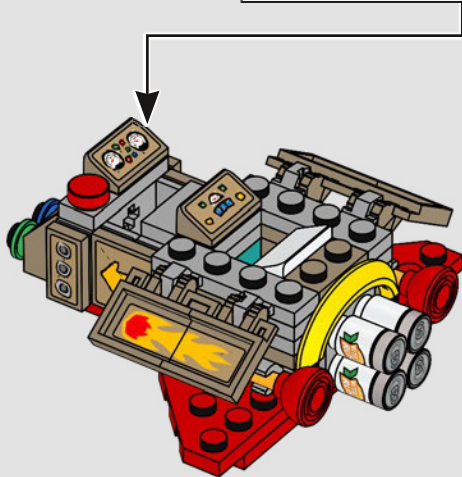



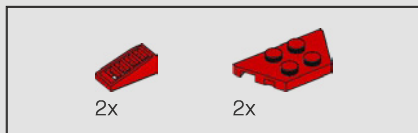

24

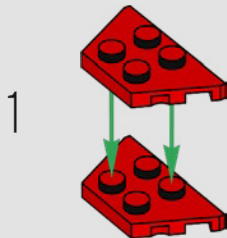

2

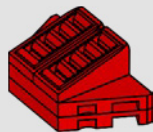

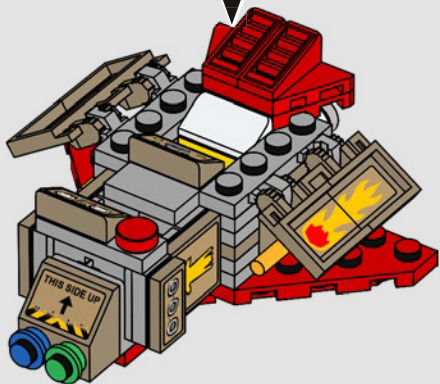

25







4x  
6310230



1x  
6284572



2x  
6171058



1x  
4547489



2x  
302301



1x  
6365487



3x  
6093526



2x  
346001



1x  
242001



1x  
6395657



1x  
4530590



1x  
302201



1x  
614123



1x  
6267163



1x  
447723



3x  
300523



4x  
4583862



2x  
6302961



1x  
362323



1x  
6092582



1x  
306923



1x  
302323



8x  
300923



1x  
306823



2x  
6129747



1x  
4558606



8x  
362223



1x  
6295977



3x  
301023



4x  
300423



1x  
6253907



1x  
6152101



2x  
6150307



1x  
6331949



1x  
4649741



1x  
6060857



2x  
6185308



1x  
6314091



1x  
6121896



1x  
6344180



2x  
6171840



3x  
6396575



1x  
306228



1x  
4569058



1x  
6182674



1x  
6055832



2x  
4549436



1x  
6395585



2x  
6015449



2x  
4521914



2x  
4496699



3x  
4528604



1x  
6184880



2x  
4507045



1x  
4626904



2x  
4267874



2x  
6397921



1x  
4631385



5x  
4528488



4x  
6199898



4x  
4252437



3x  
6167776



2x  
6376752



1x  
6359662



1x  
4529242



1x  
6170418



1x  
6372781



1x  
6258831



6x  
4211399



2x  
6252203



2x  
6362975



3x  
6335378



4x  
6322904



1x  
6096993



1x  
6046398



2x  
6330125



4x  
6344022



2x  
4211398



1x  
6206249



3x  
4211445



1x  
4211395



3x  
4211406

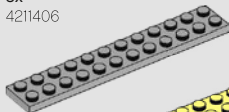

2x  
4211360



2x  
6337268



1x  
6212077



2x  
4211353



1x  
4211429



2x  
6276045

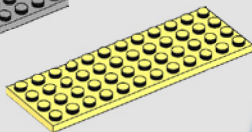

3x  
6290533



4x  
4654580



2x  
6375350



1x  
6296963



2x  
6348060



1x  
4529234



1x  
6284574



4x  
6278445



1x  
6177500



1x  
6331234



2x  
6337734



2x  
4540382



2x  
6023770



2x  
302121



**Customer Service**  
**Kundenservice**  
**Service Consommateurs**  
**Servicio Al Consumidor**

**LEGO.com/service or dial**



**: 00800 5346 5555**



**: 1-800-422-5346**



LEGO and the LEGO logo are trademarks of the/sont des marques de commerce du/son marcas registradas de LEGO Group. ©2022 The LEGO Group. All rights reserved/Tous droits réservés/Todos los derechos reservados. 6408164