



# PIRATES of the CARIBBEAN



4184



1

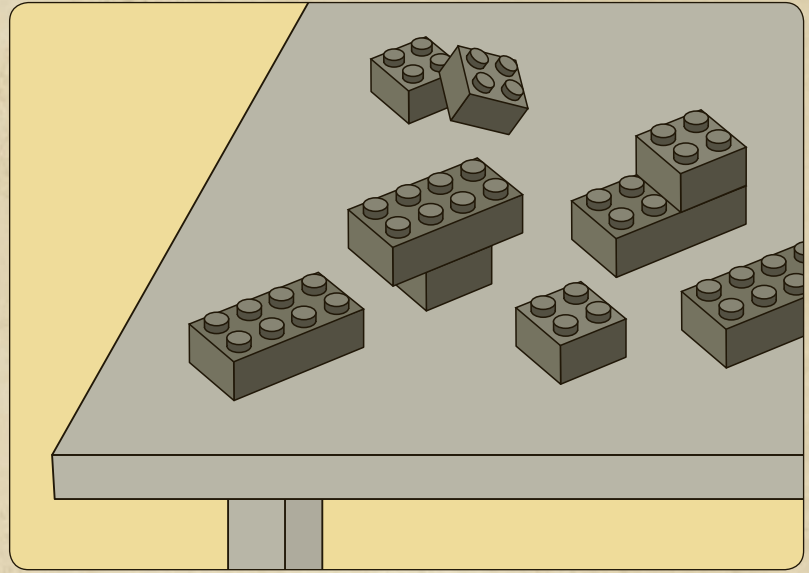
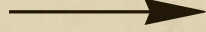
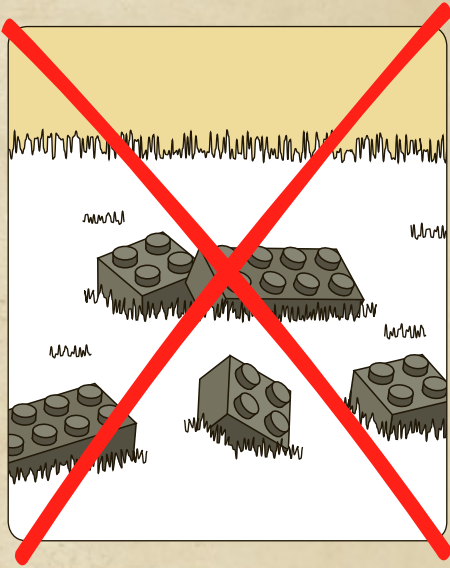

2





+

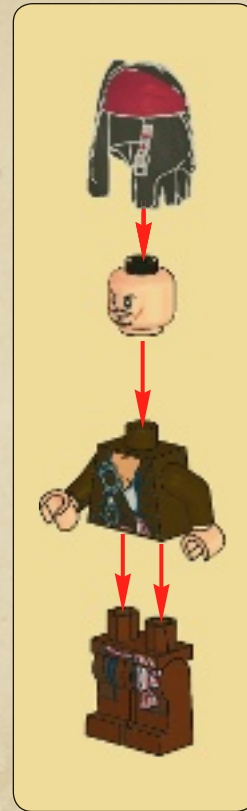

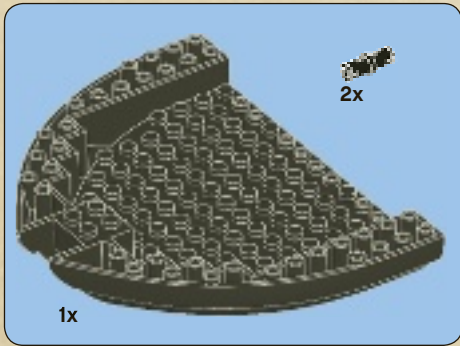
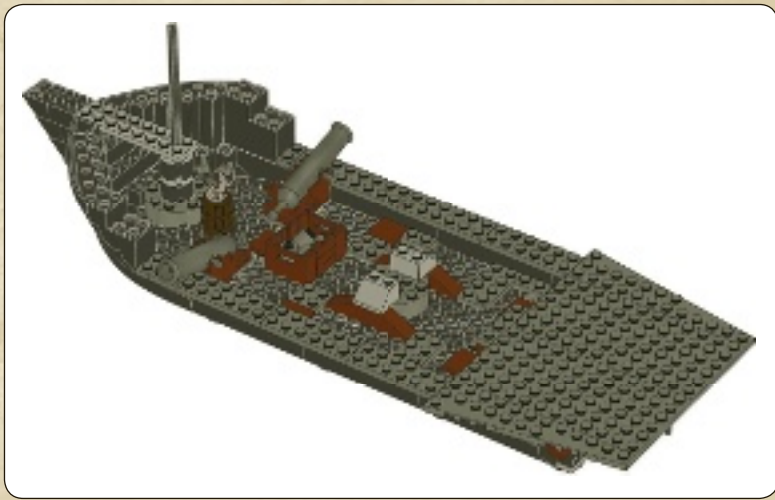

1

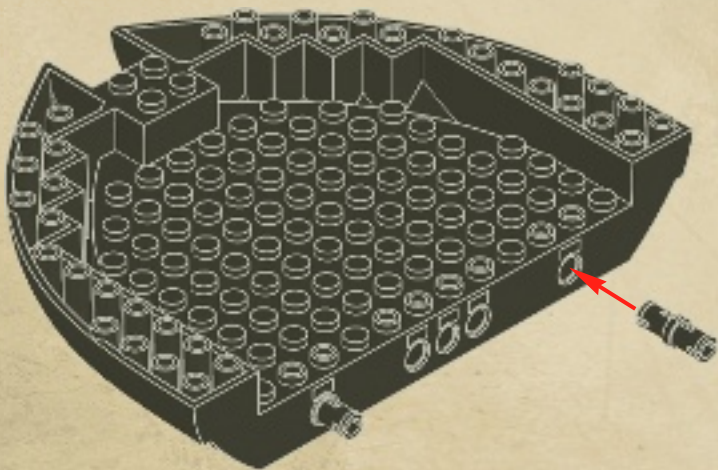

2

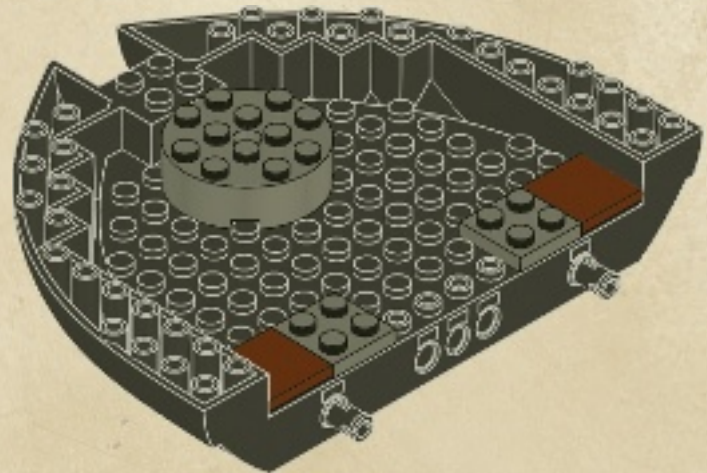

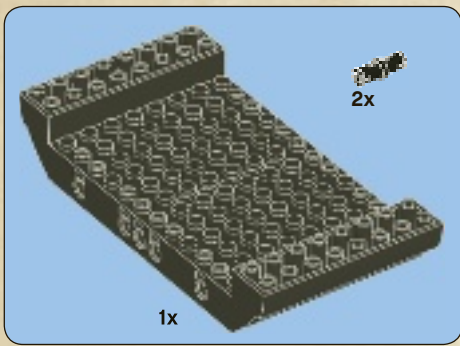

3

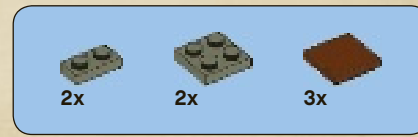
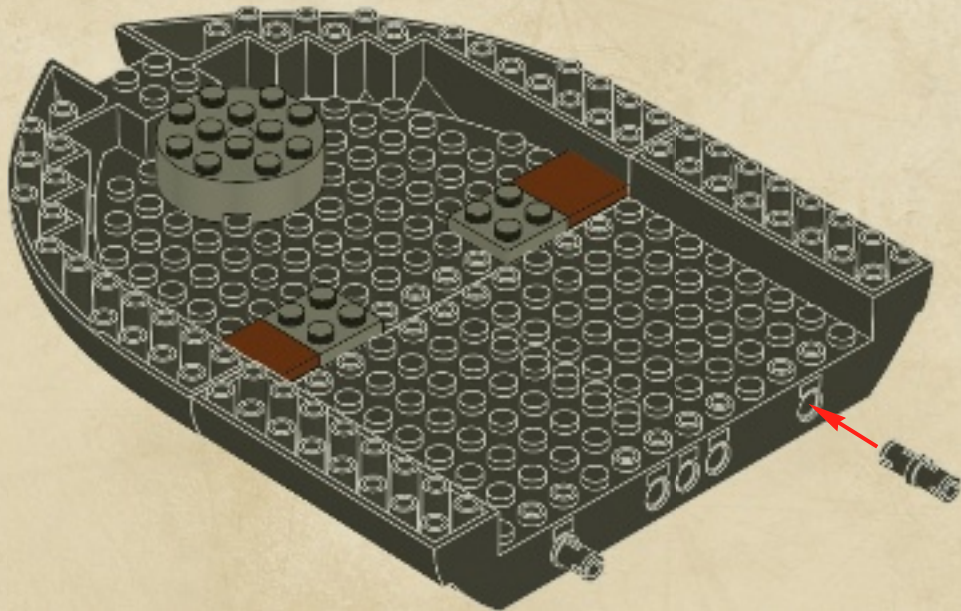

4

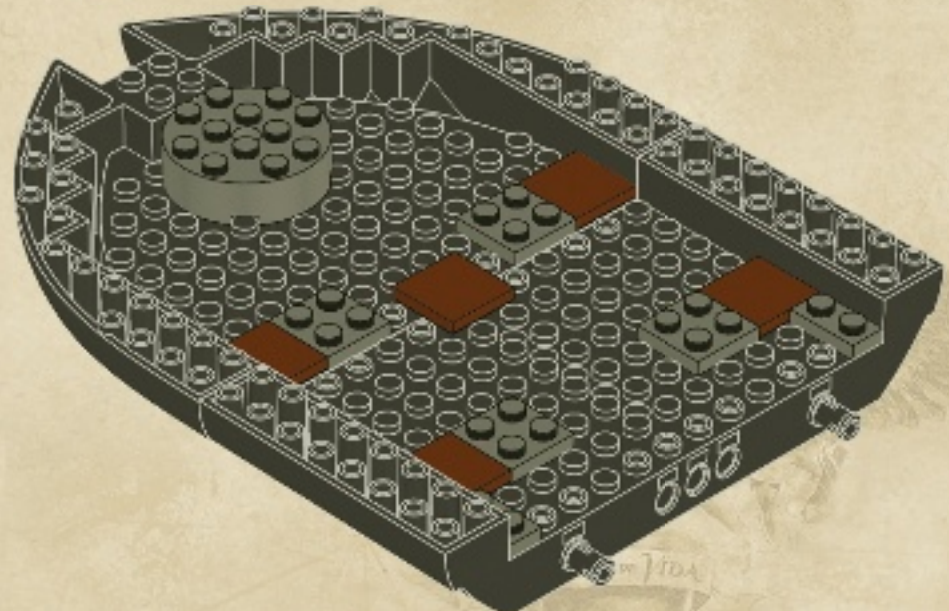

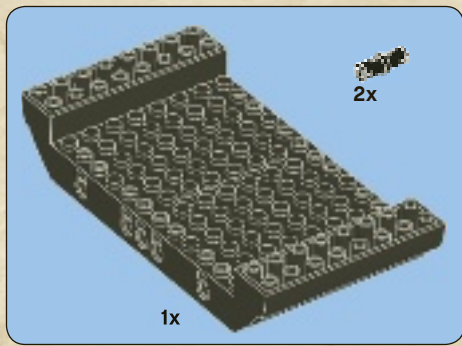

5

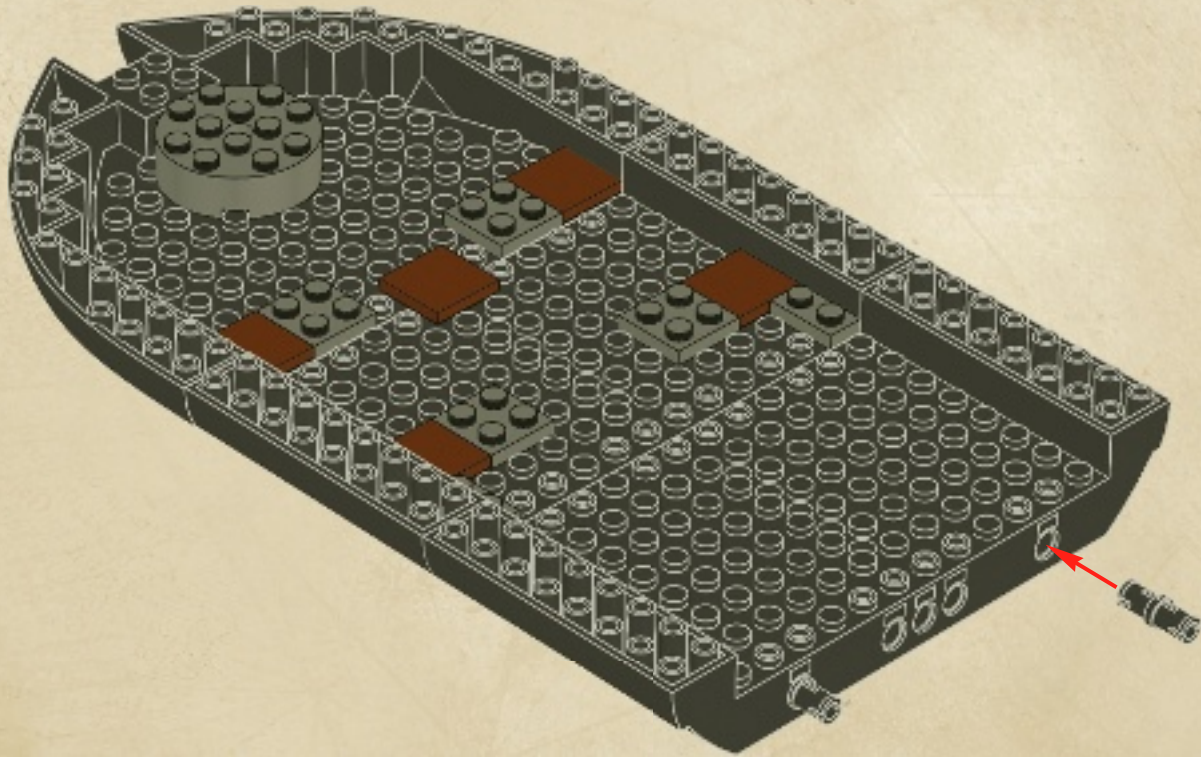

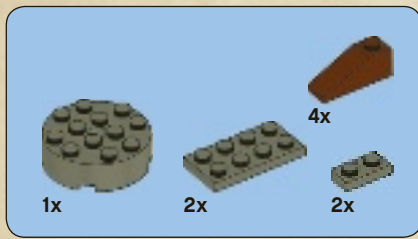

6

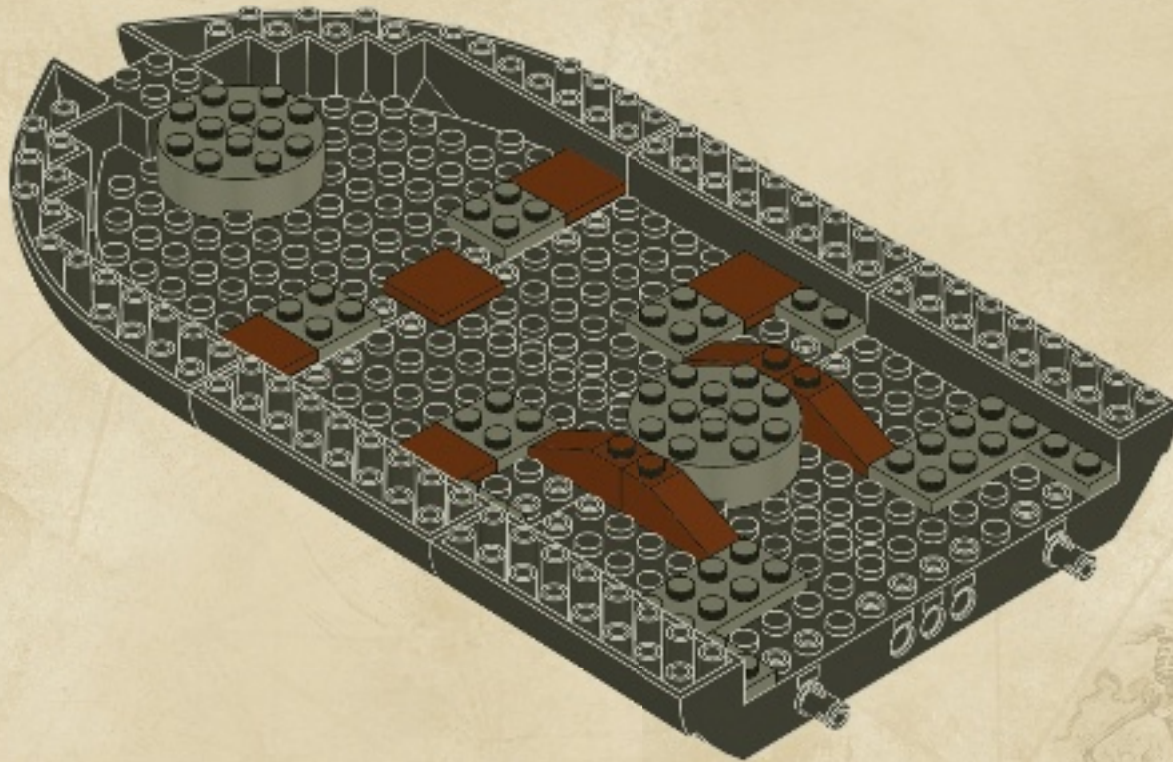

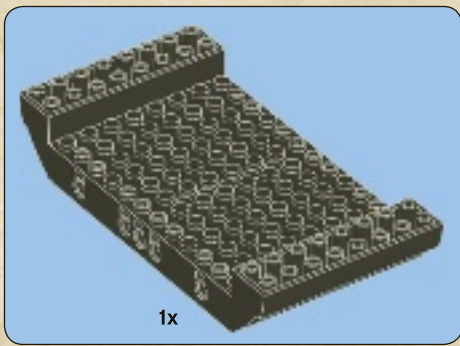

7

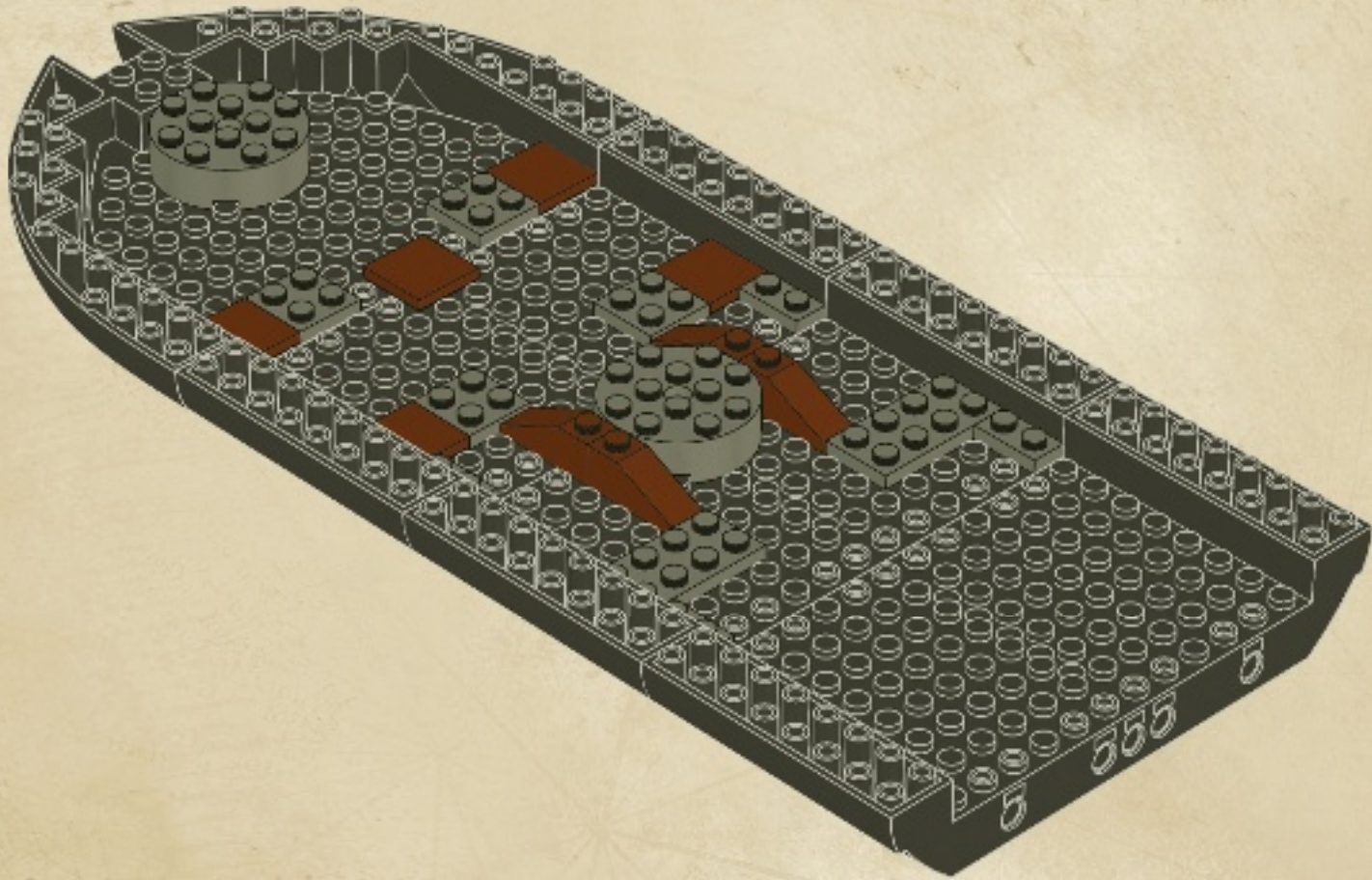





2x

8

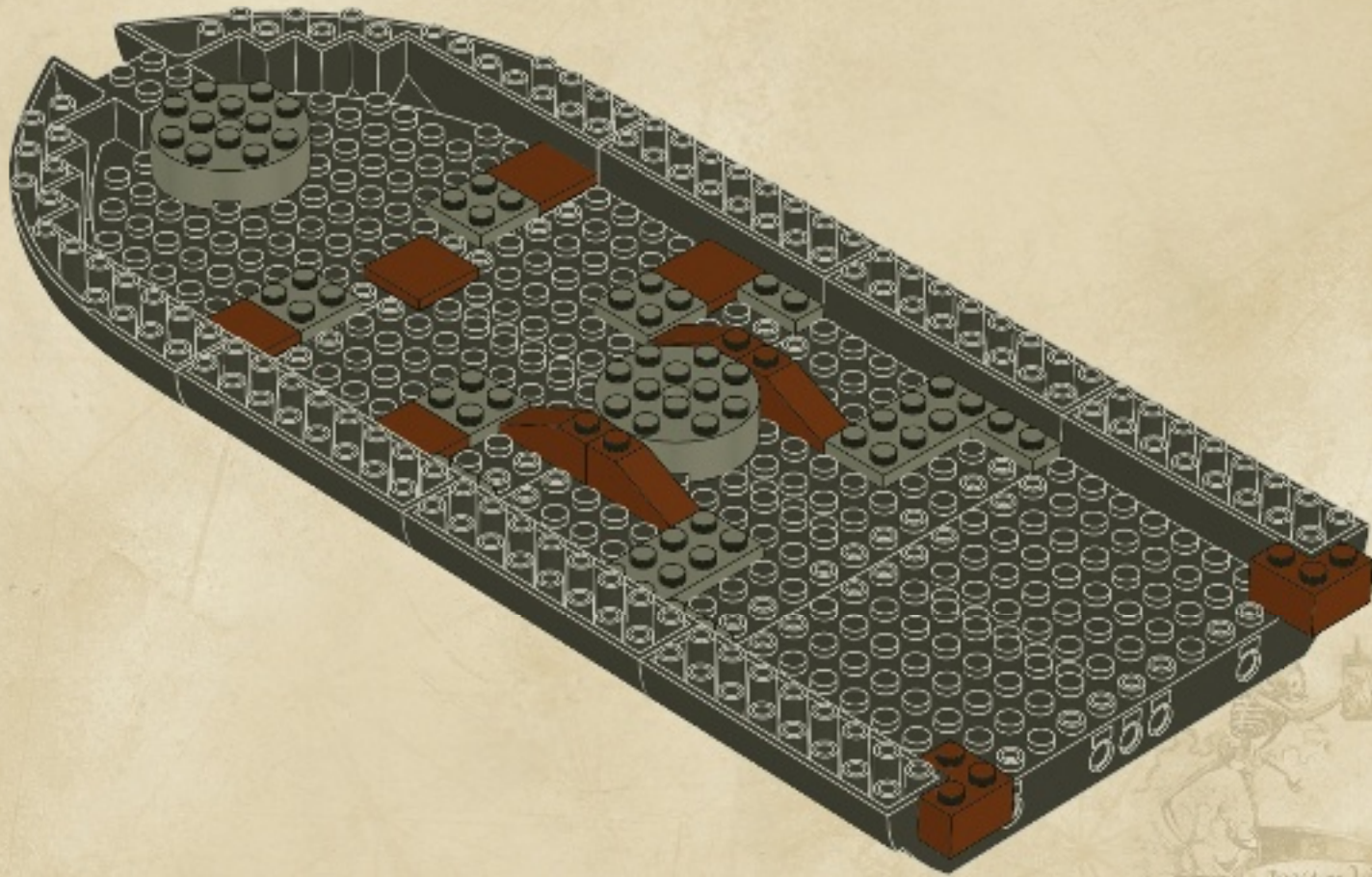

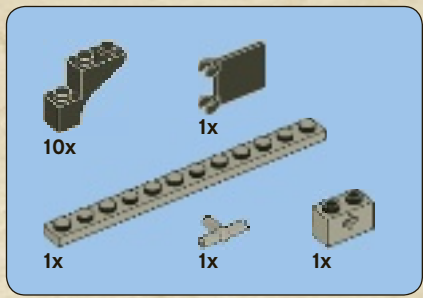

9

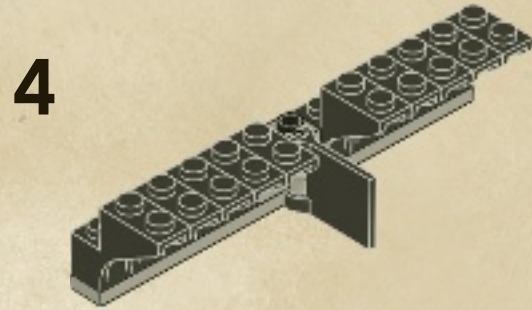
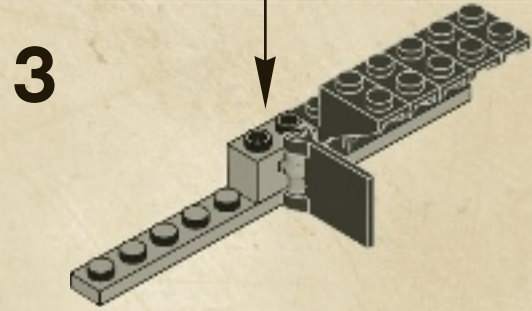
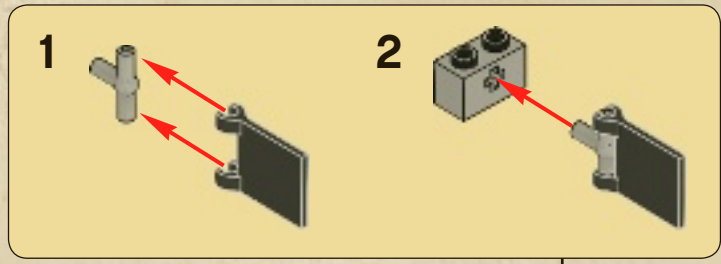
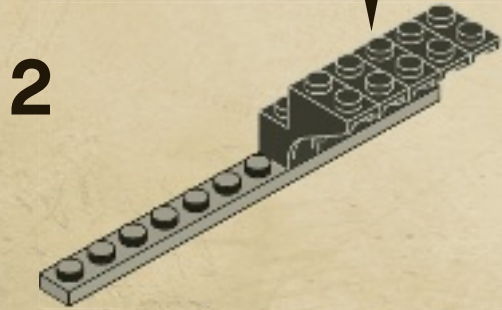
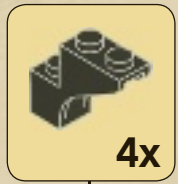
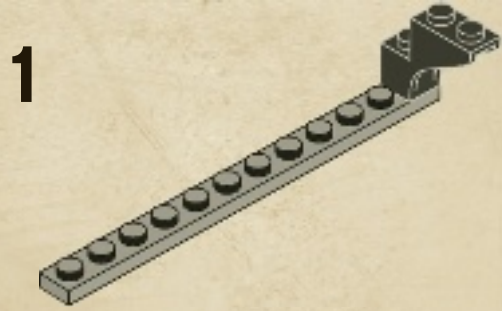

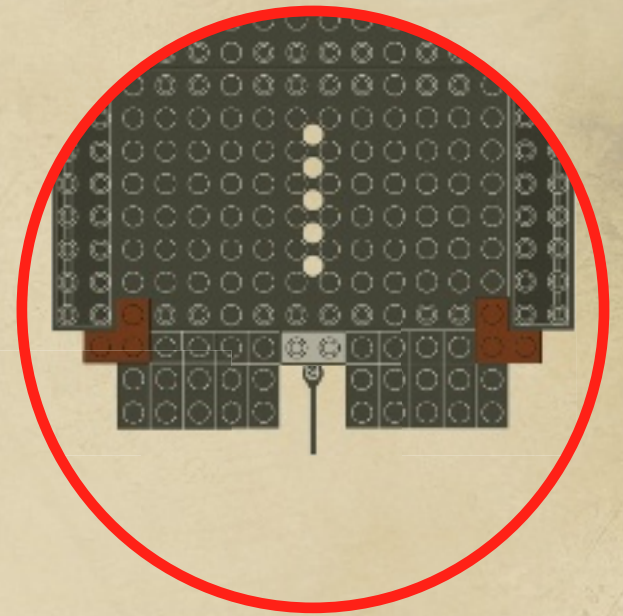
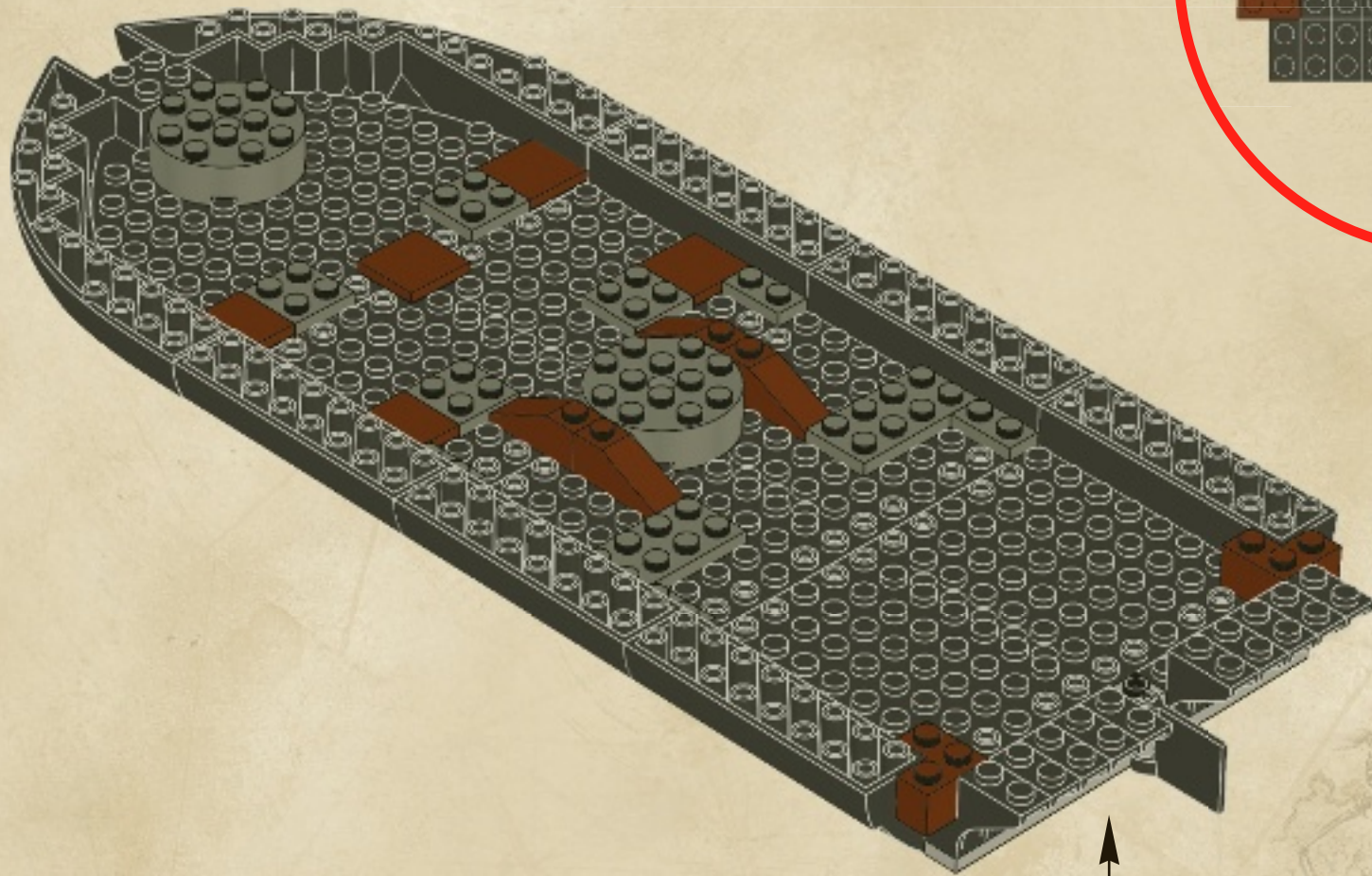



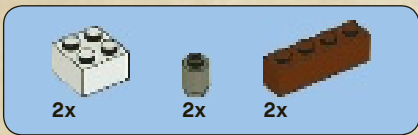

11

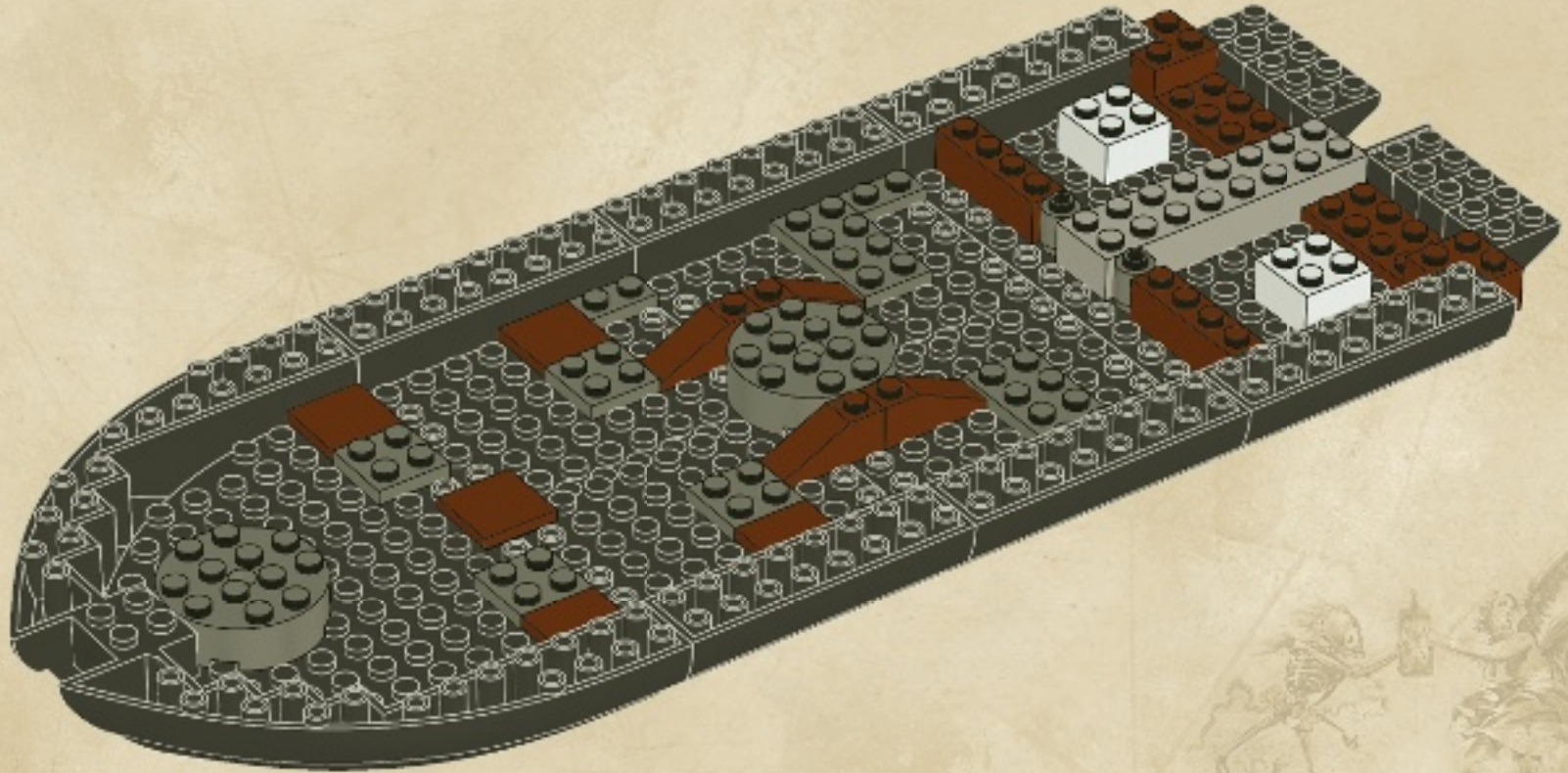



12

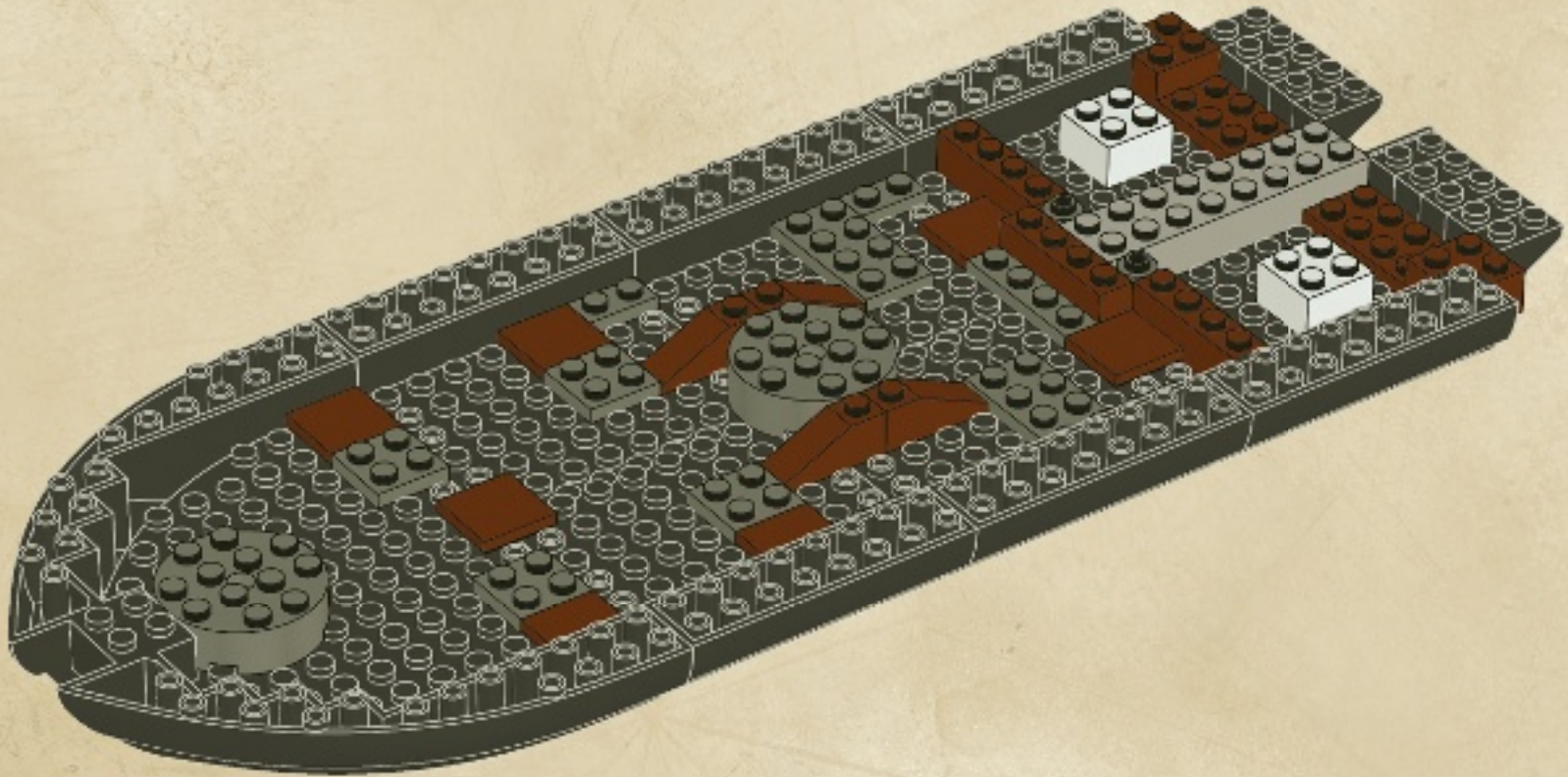



# 13

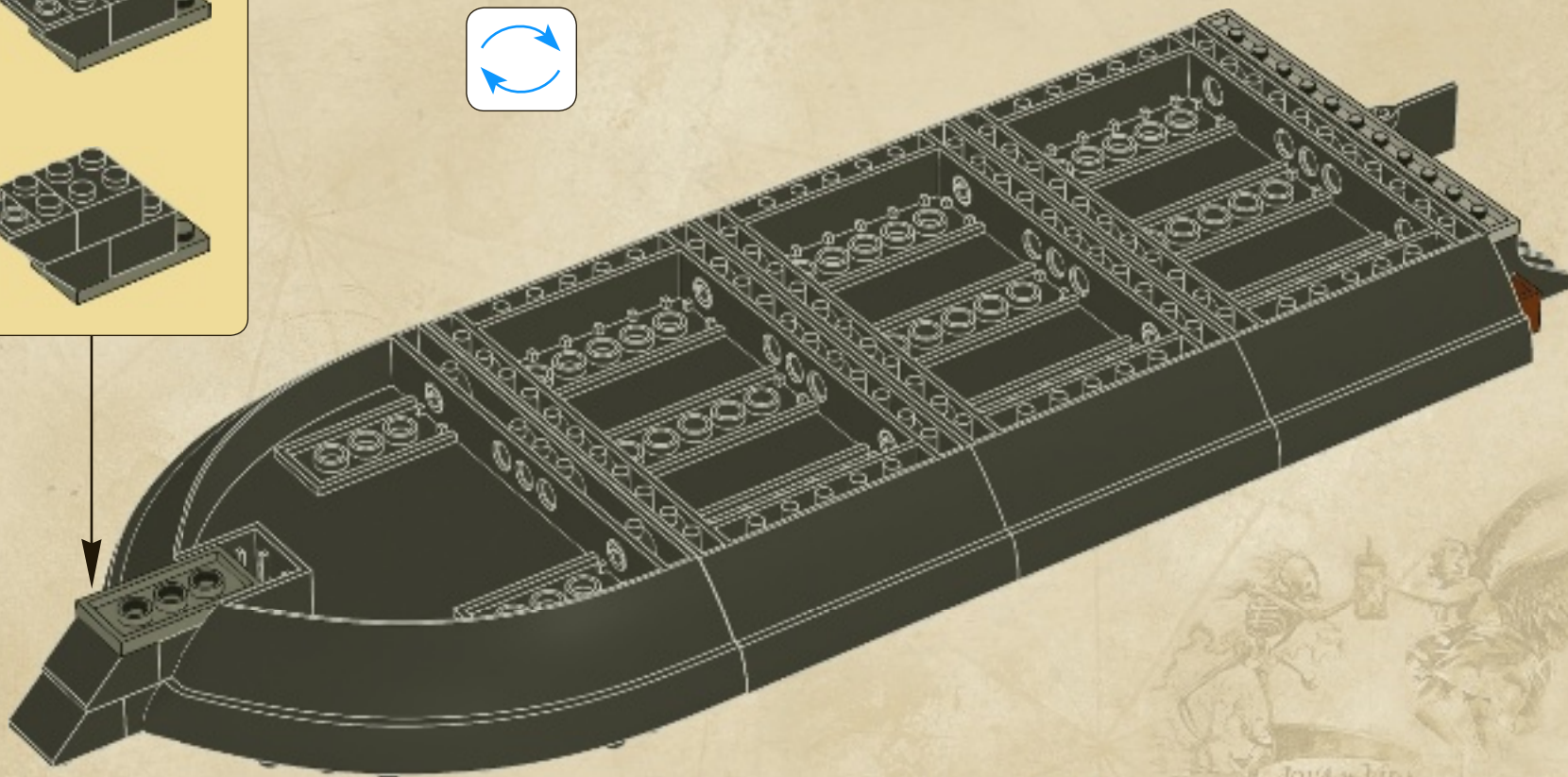
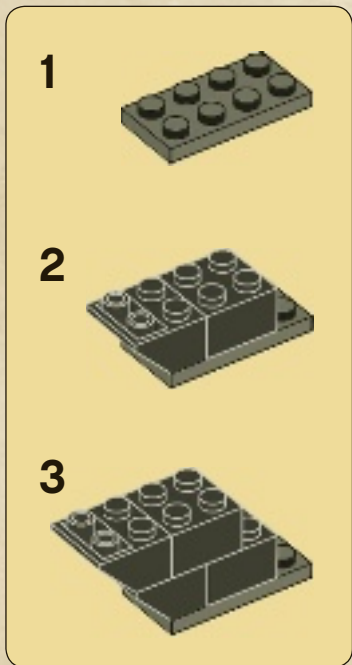



10x

14

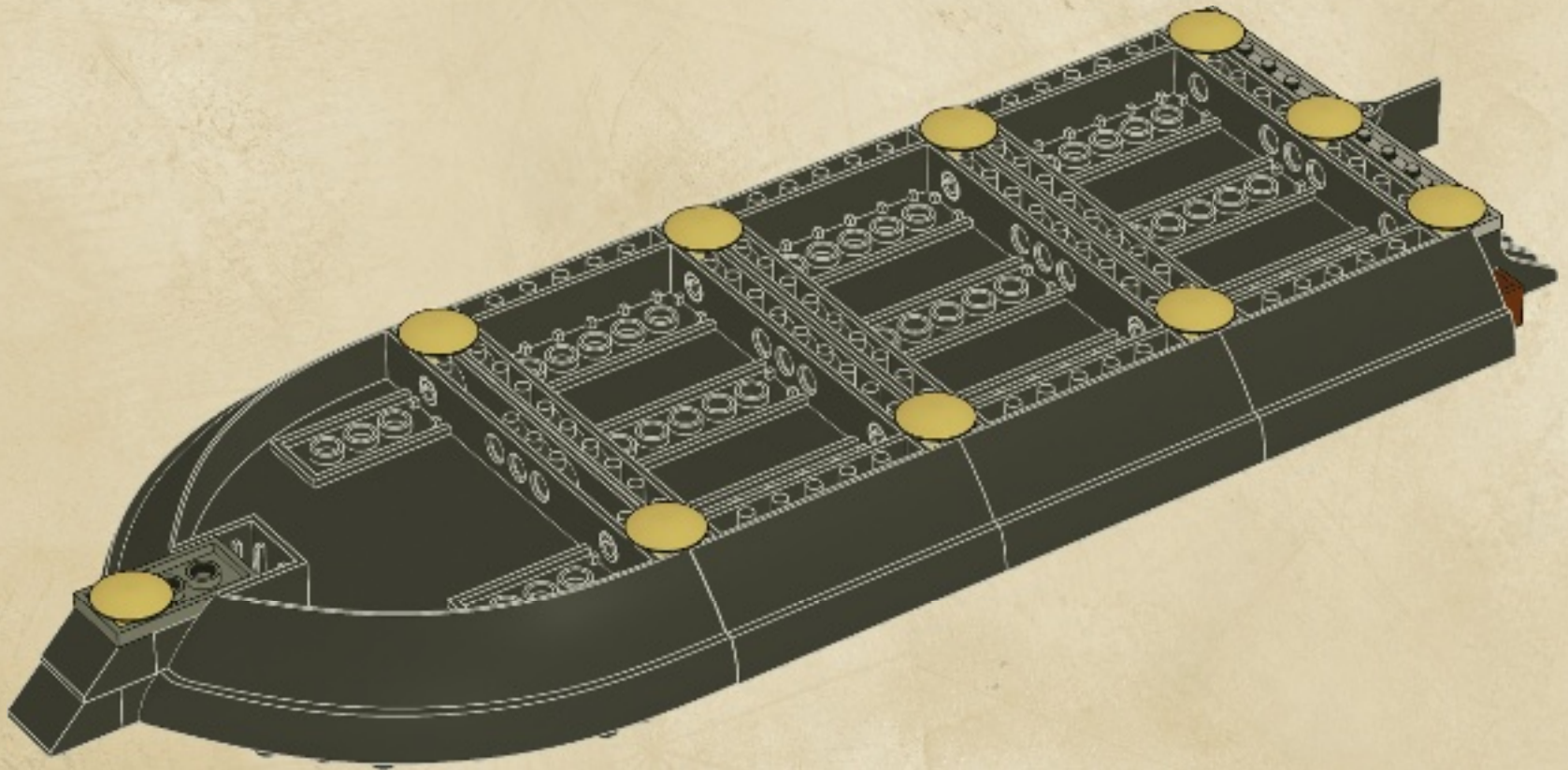



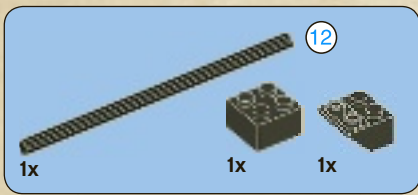

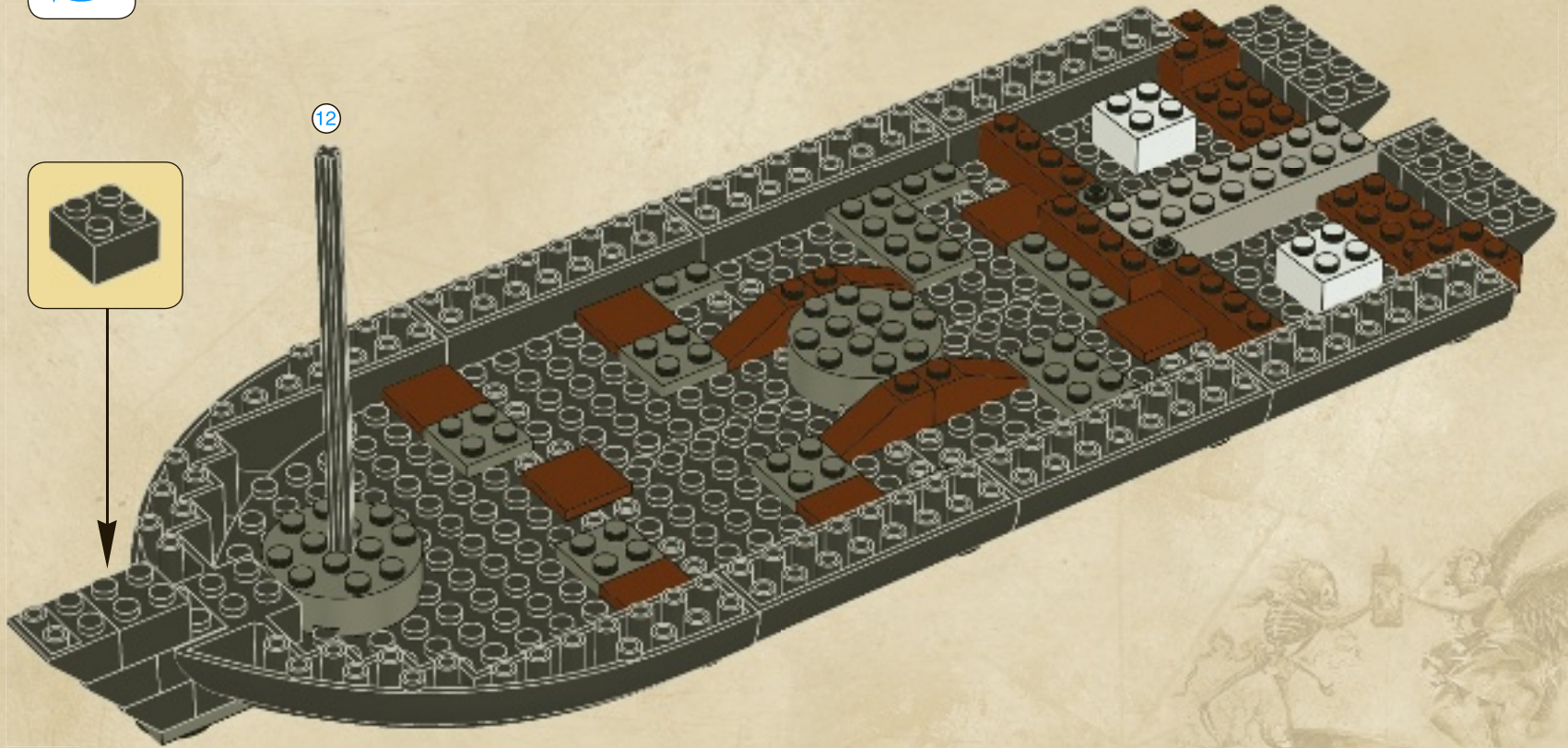

15



1x  1x 

# 16

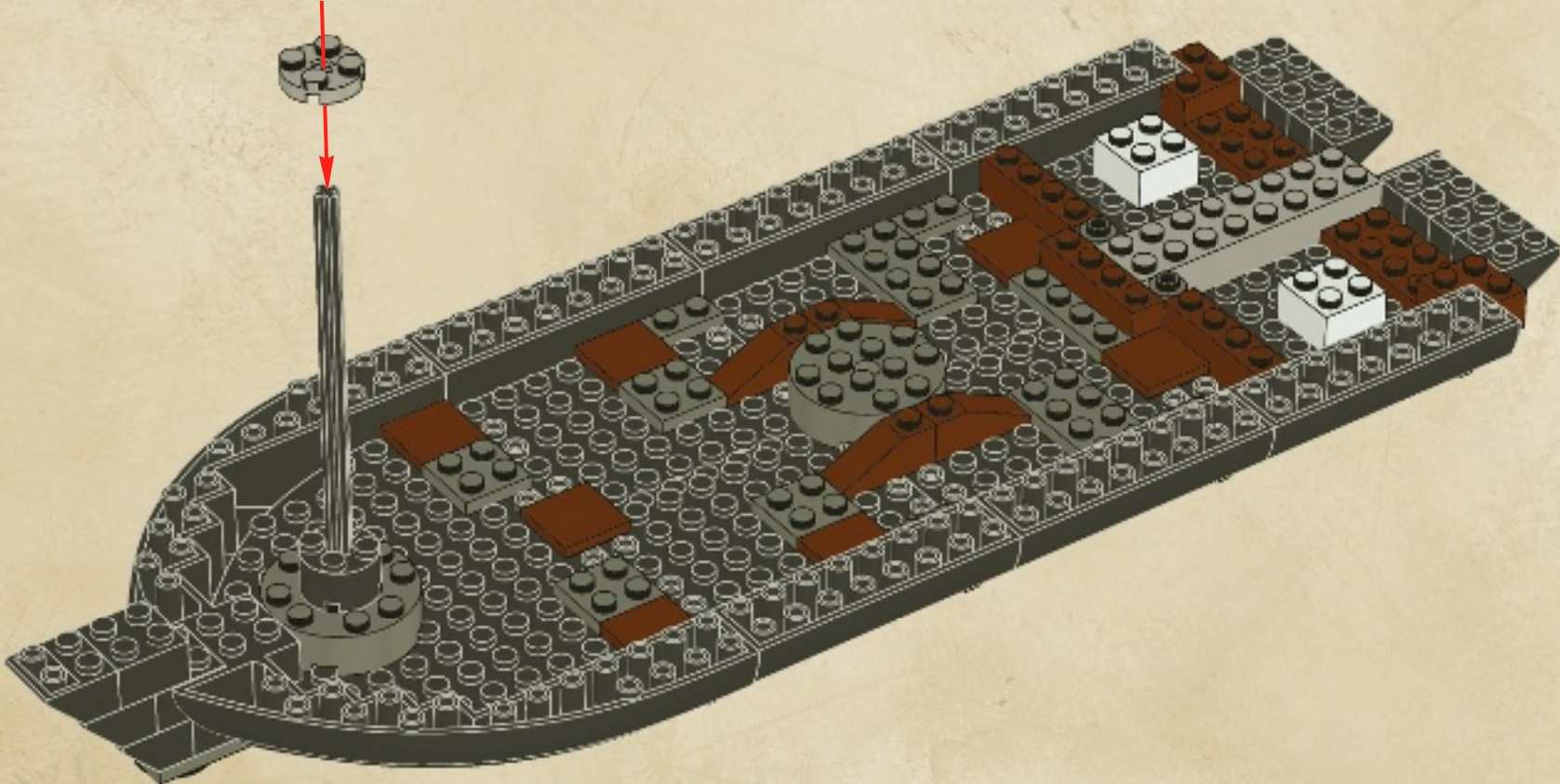

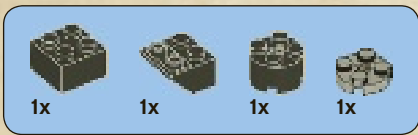

17

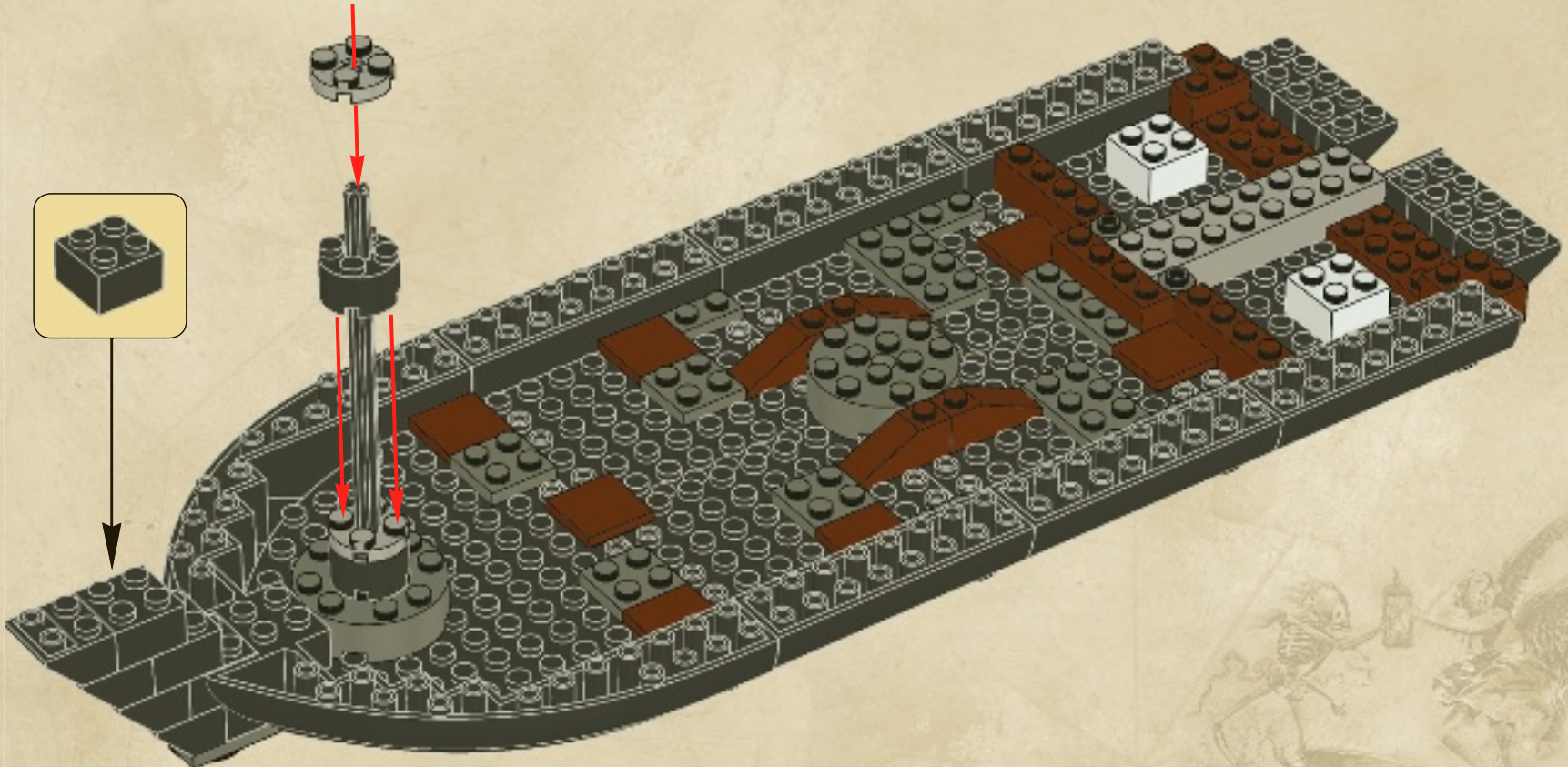

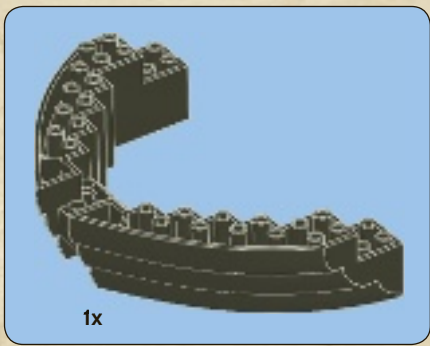

18

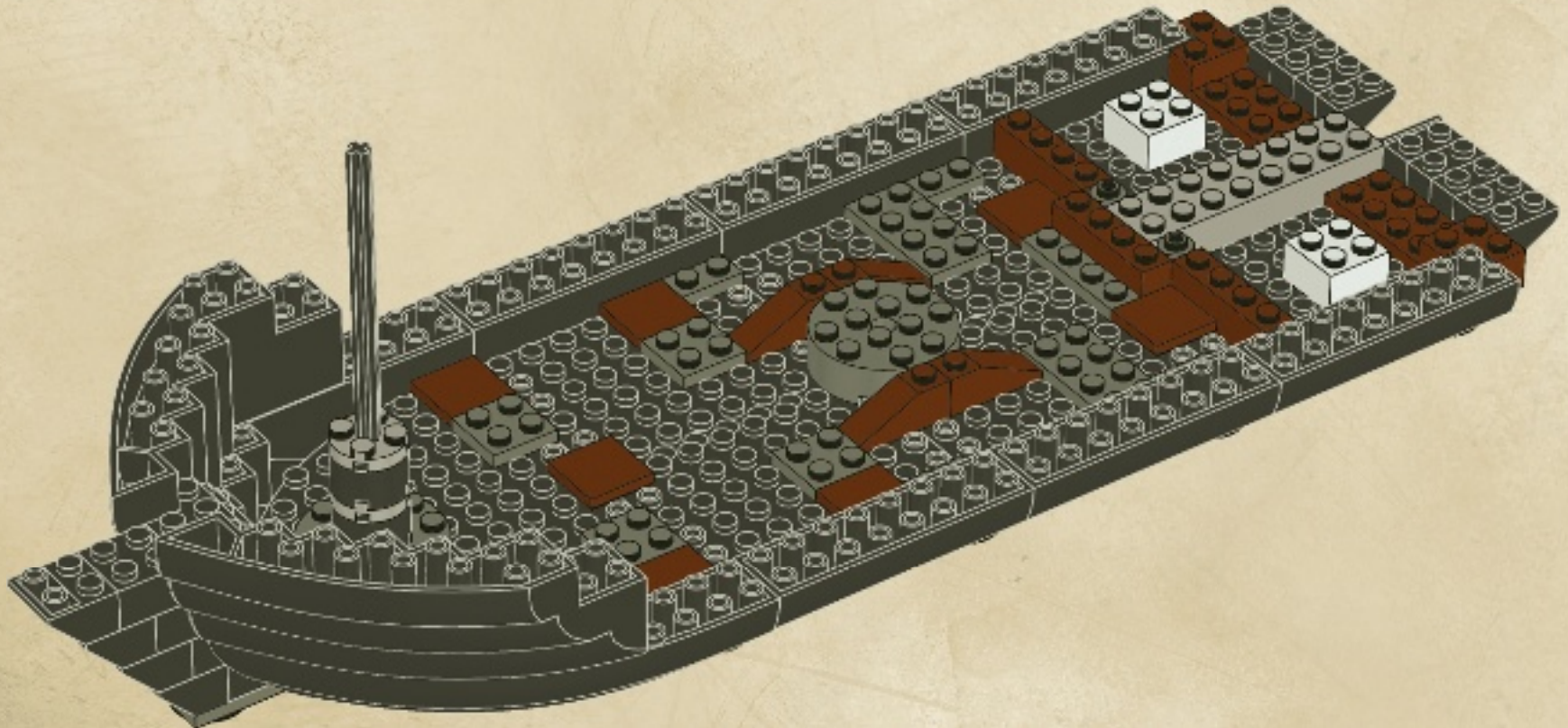

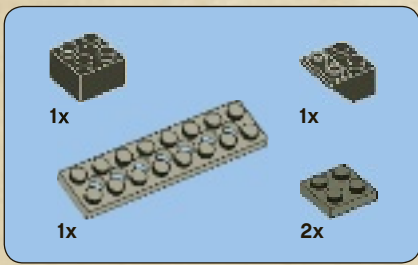

# 19

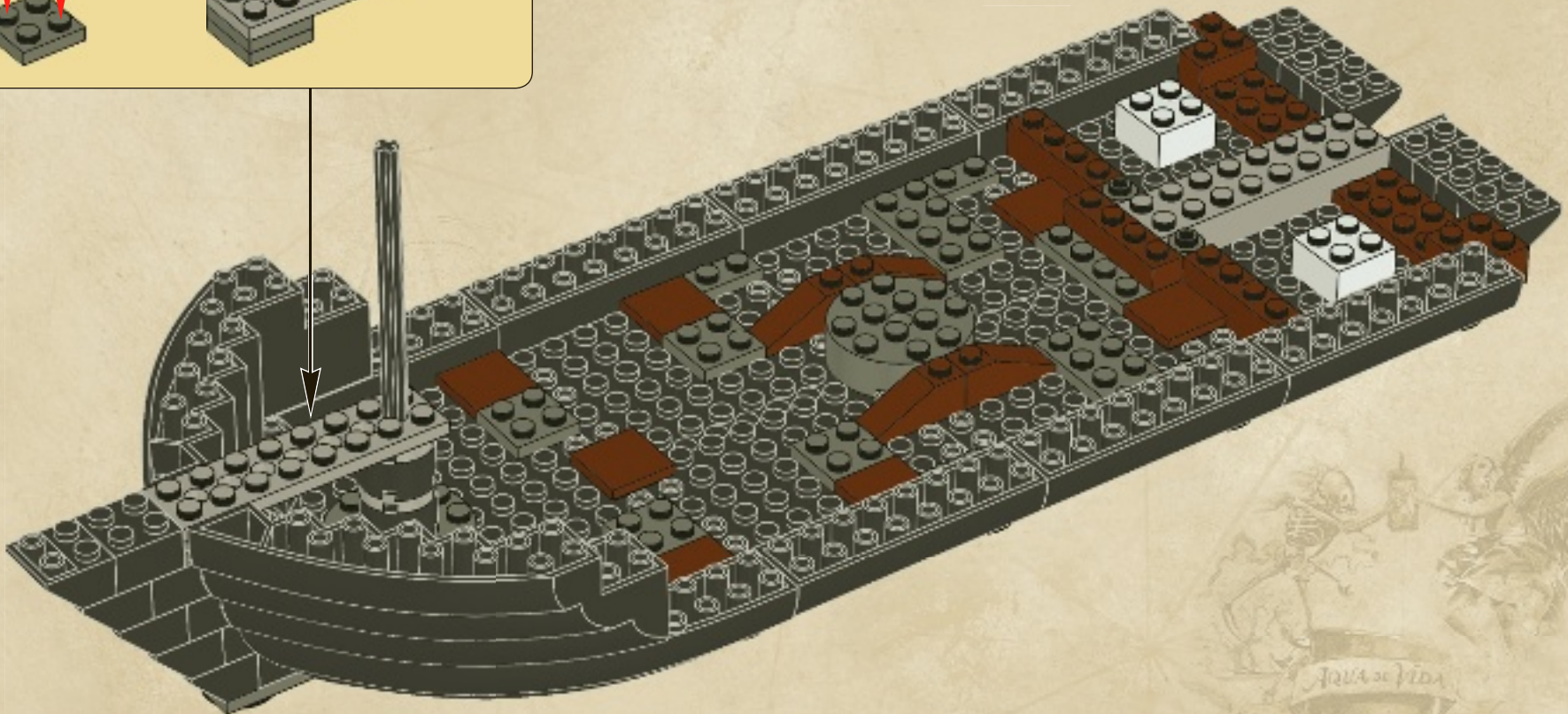
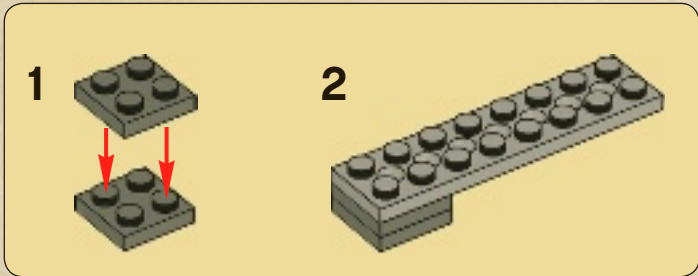

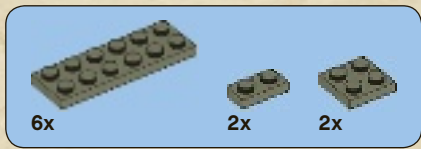

20

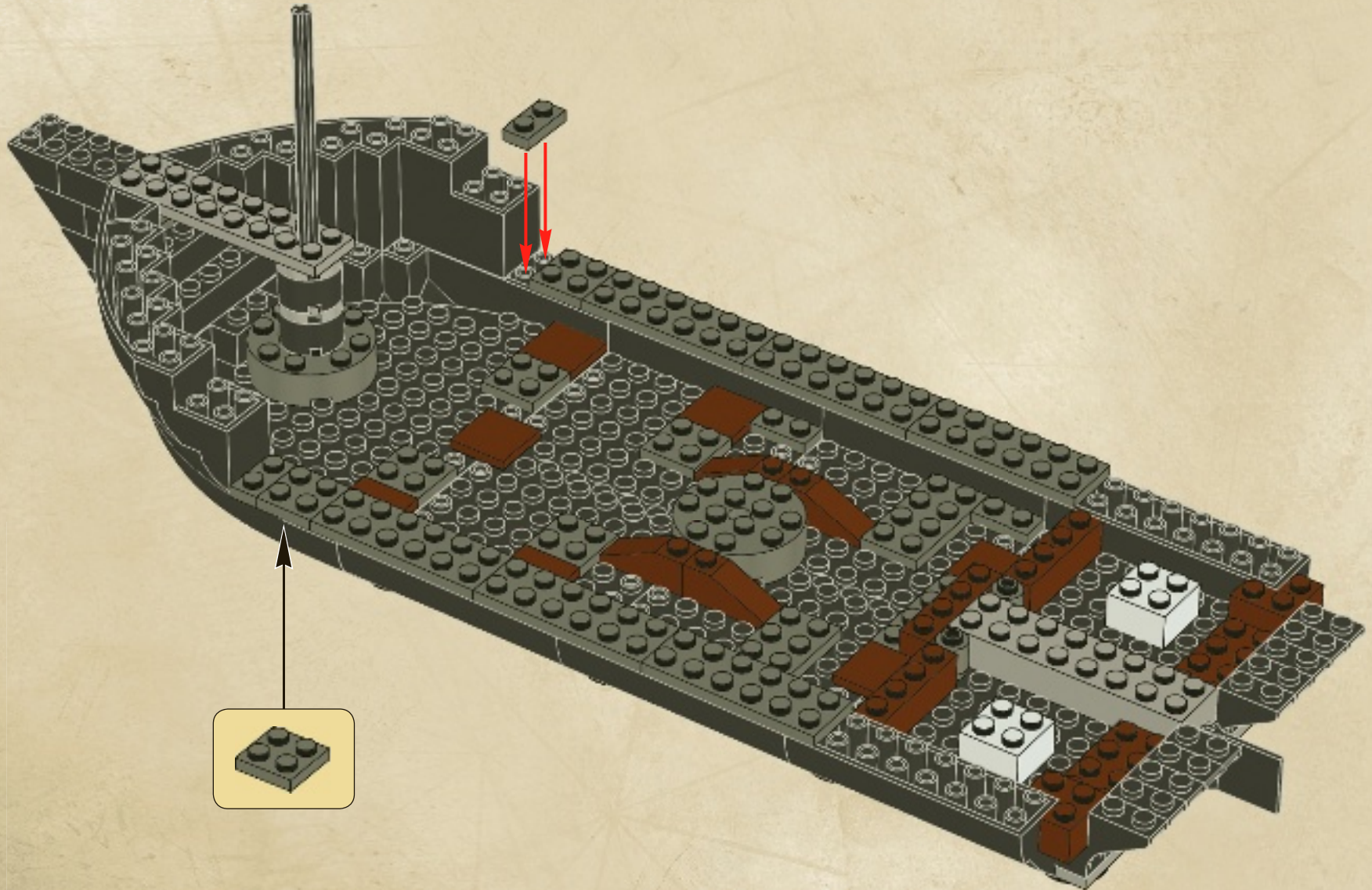



21

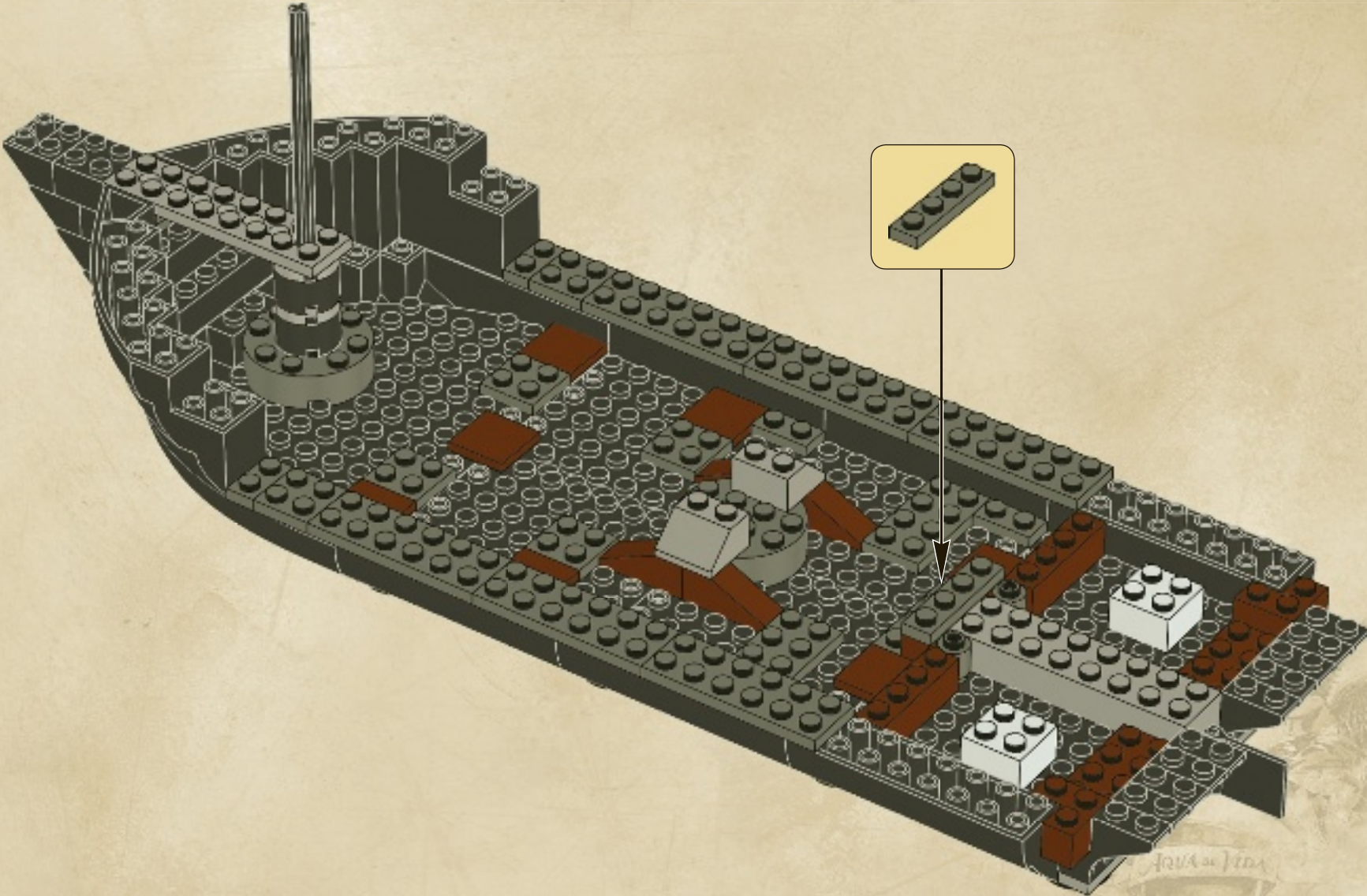

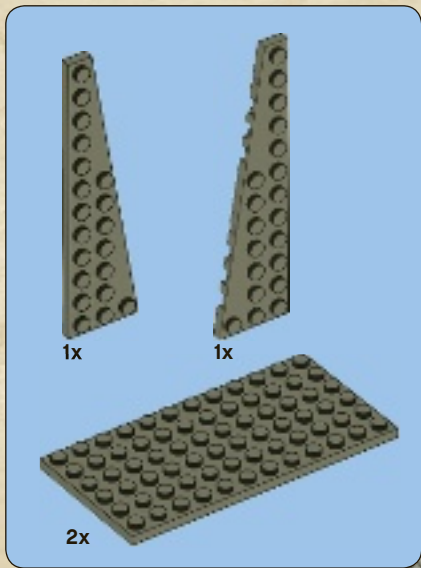

22

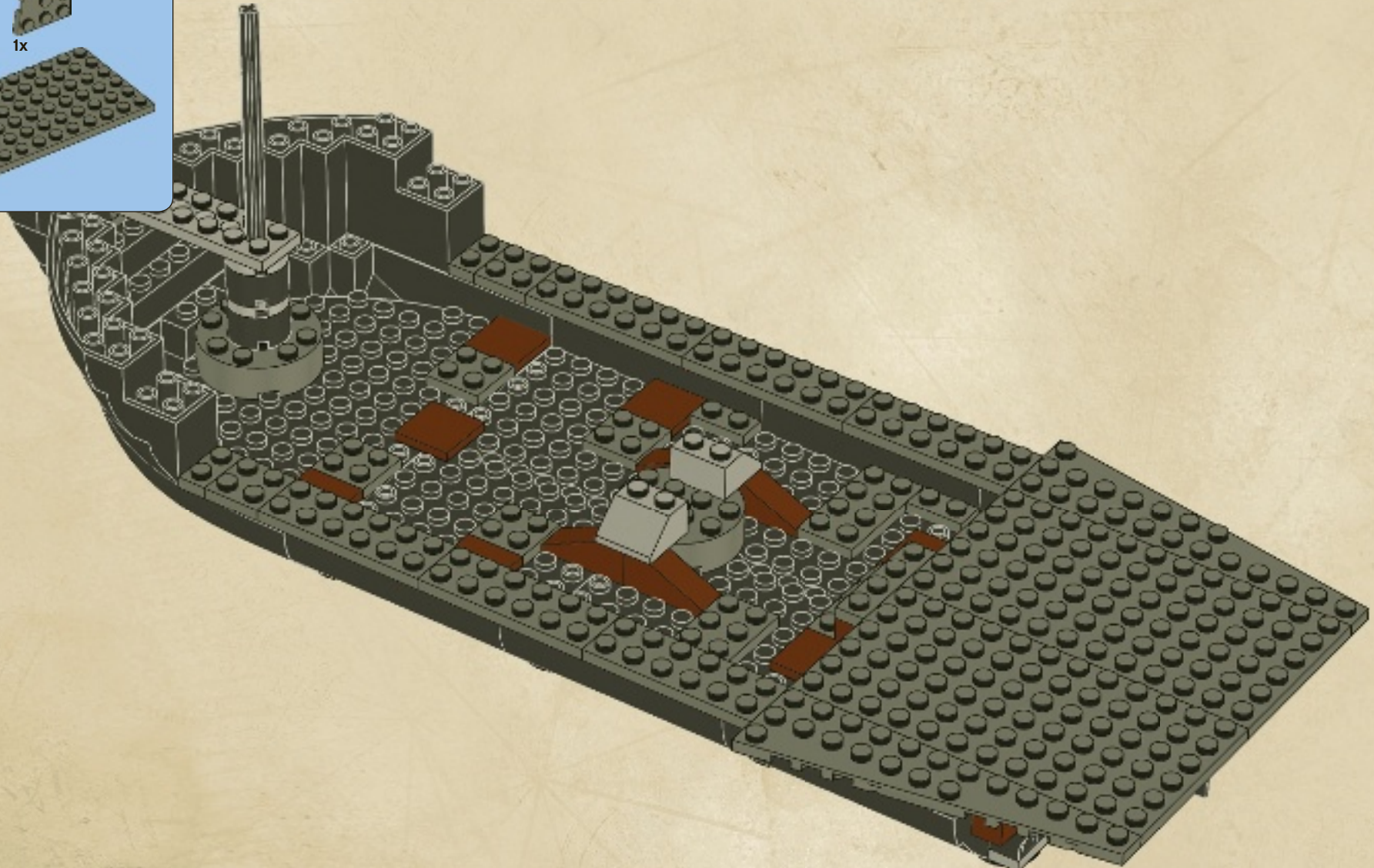





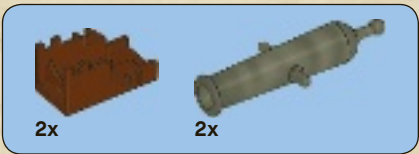

24

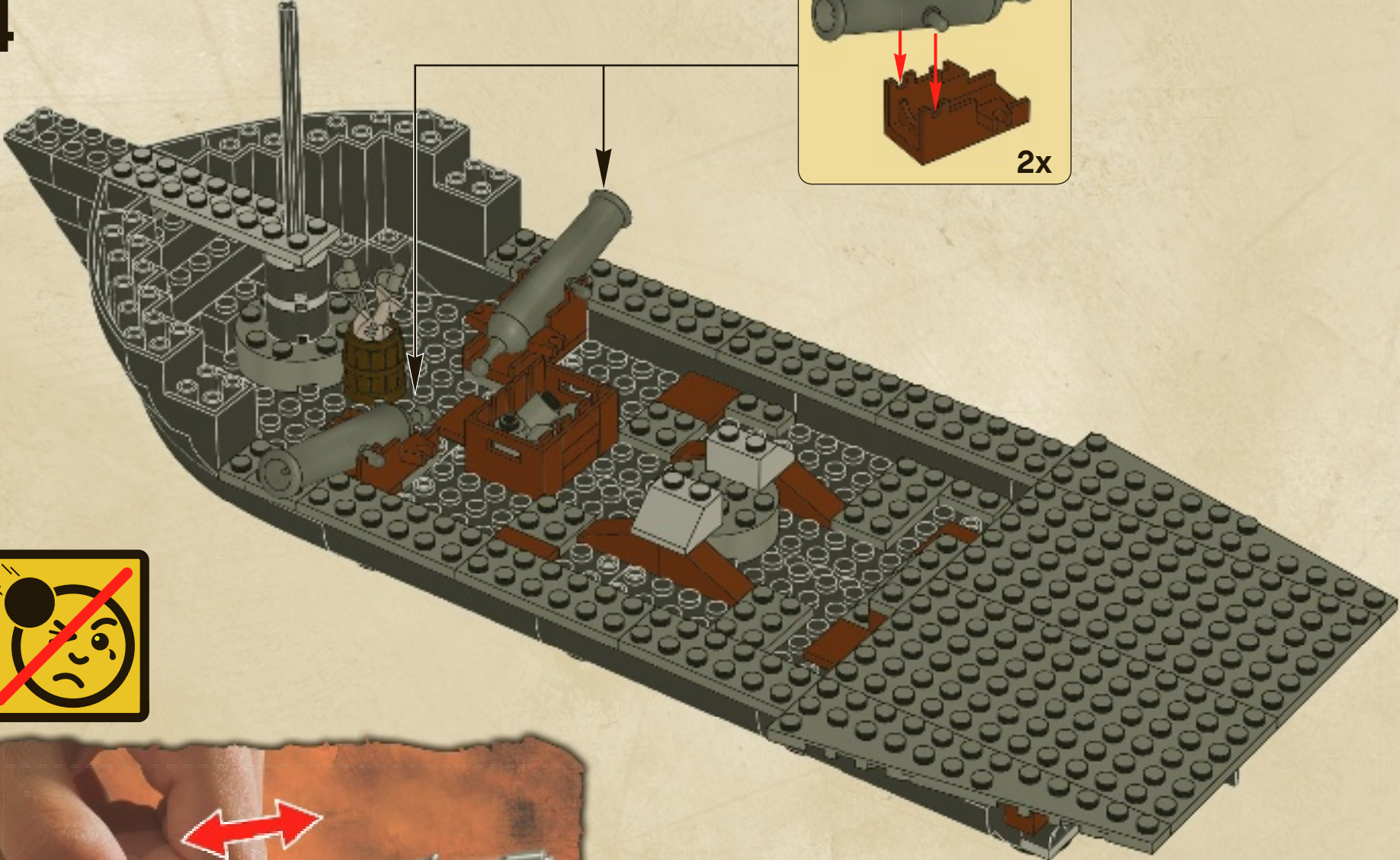
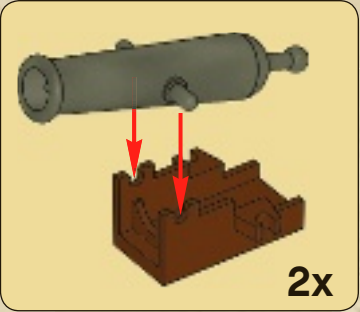

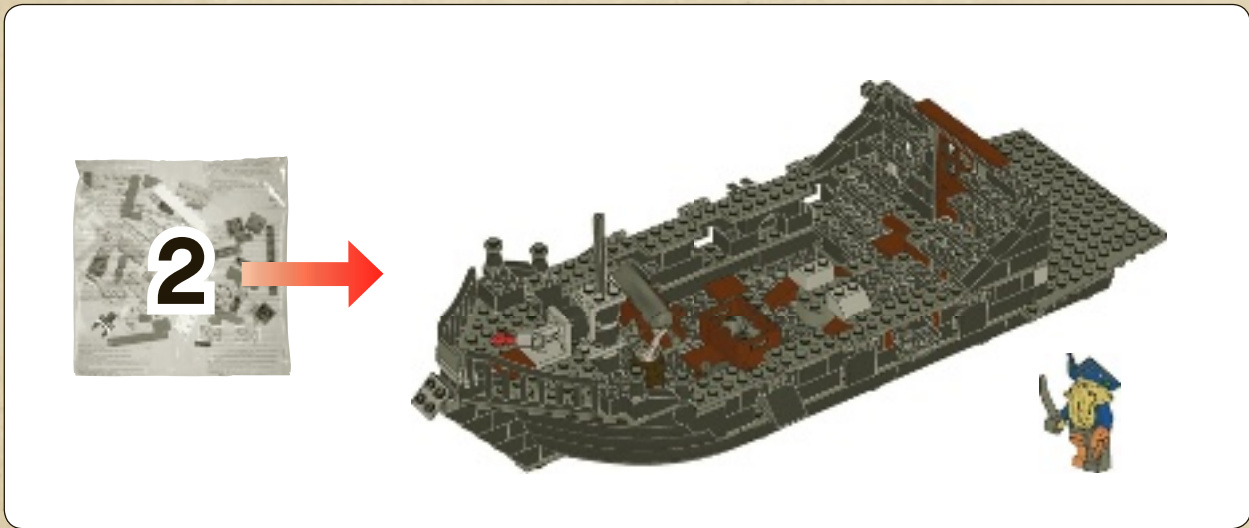



2x 4x

26

2x

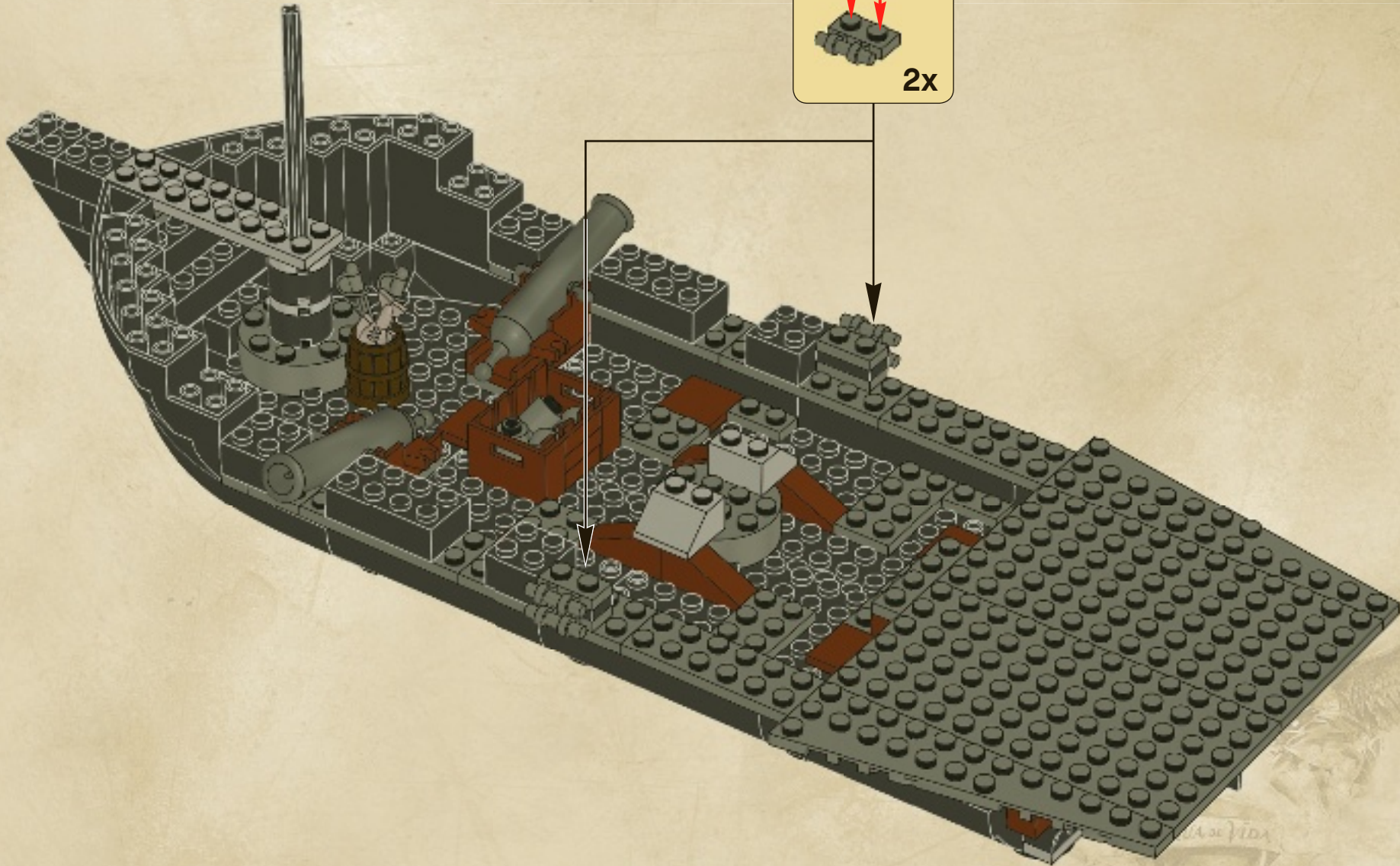



27

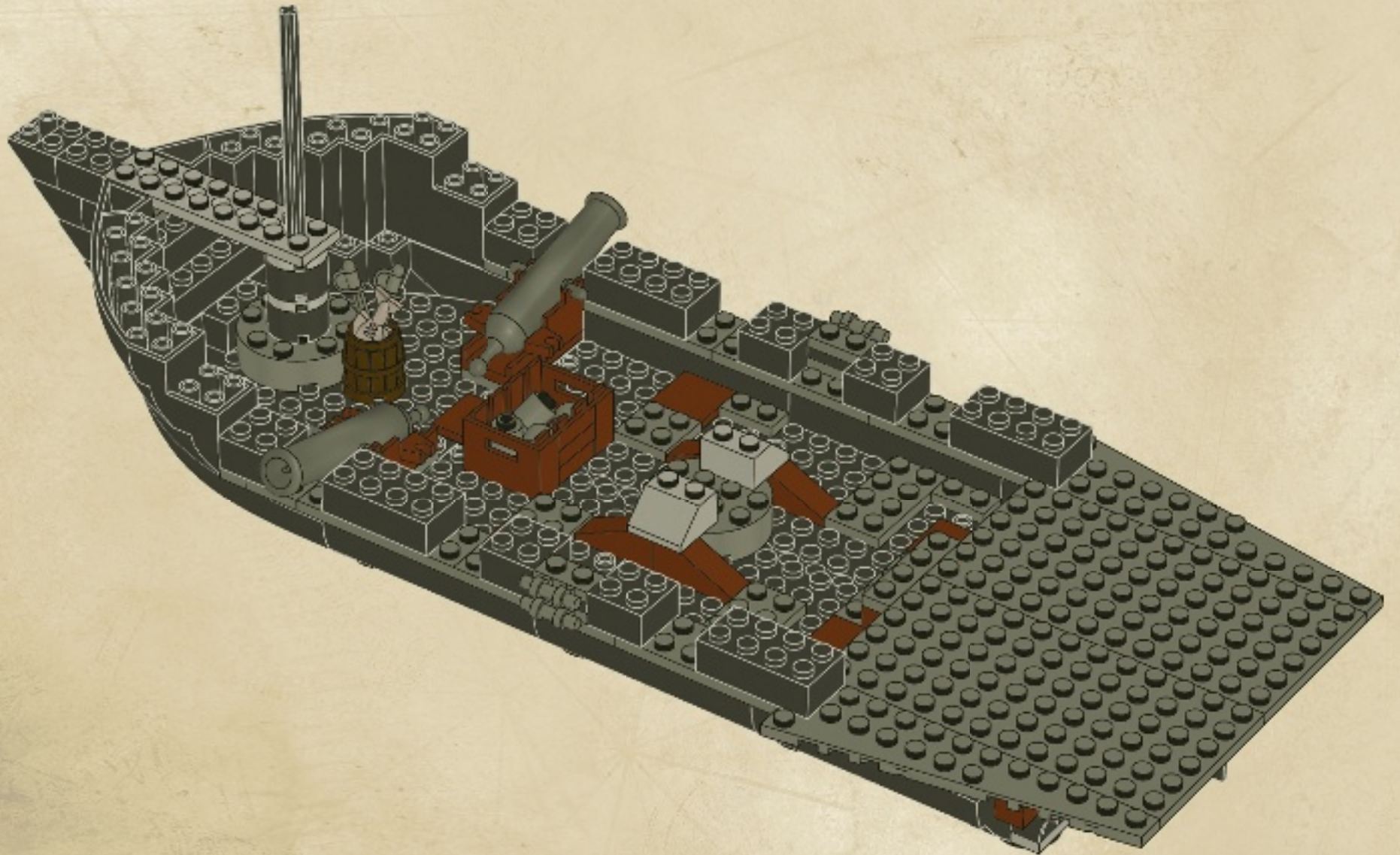



2x



2x

# 28

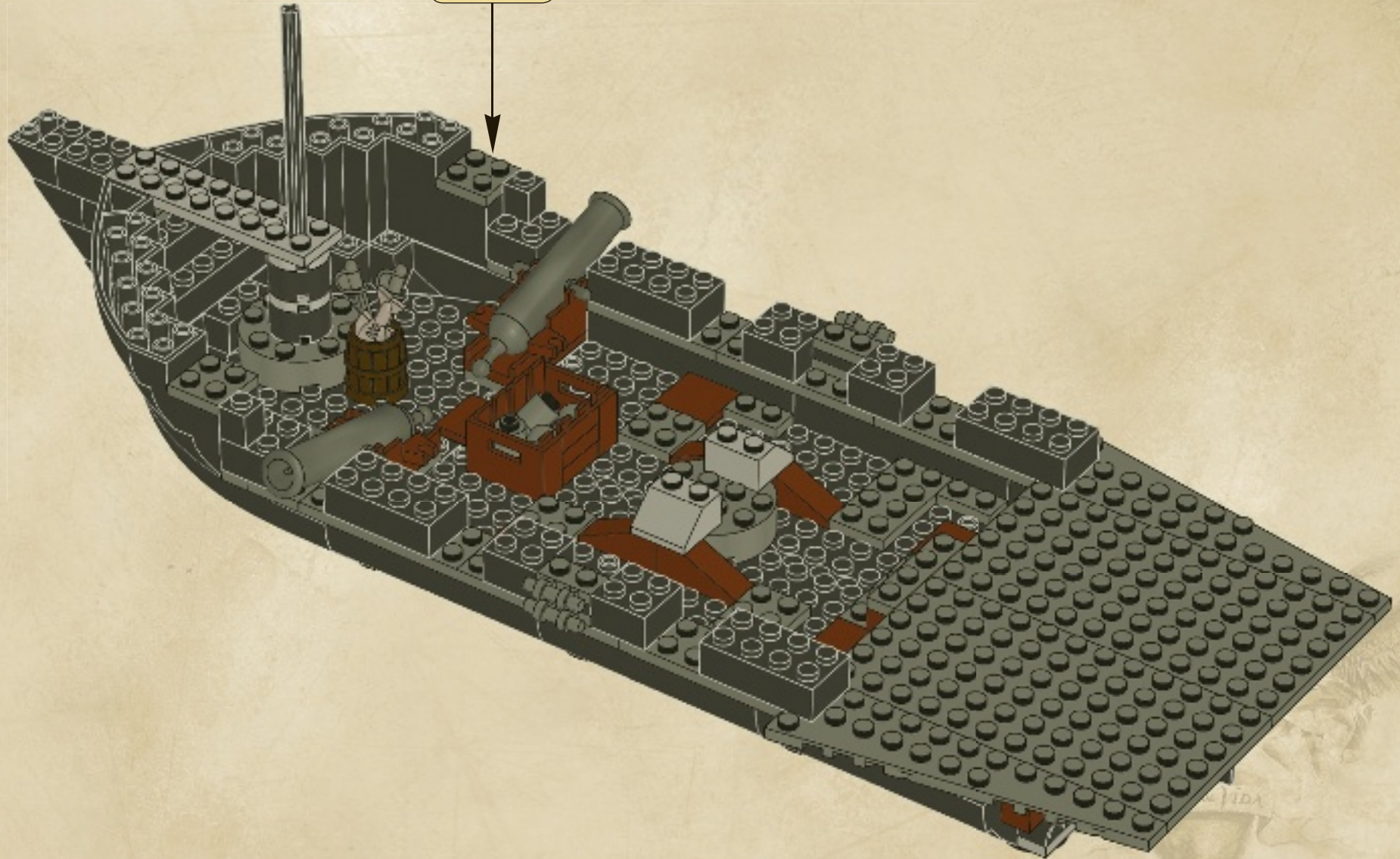
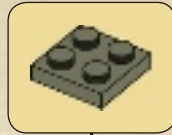



2x



6x

# 29

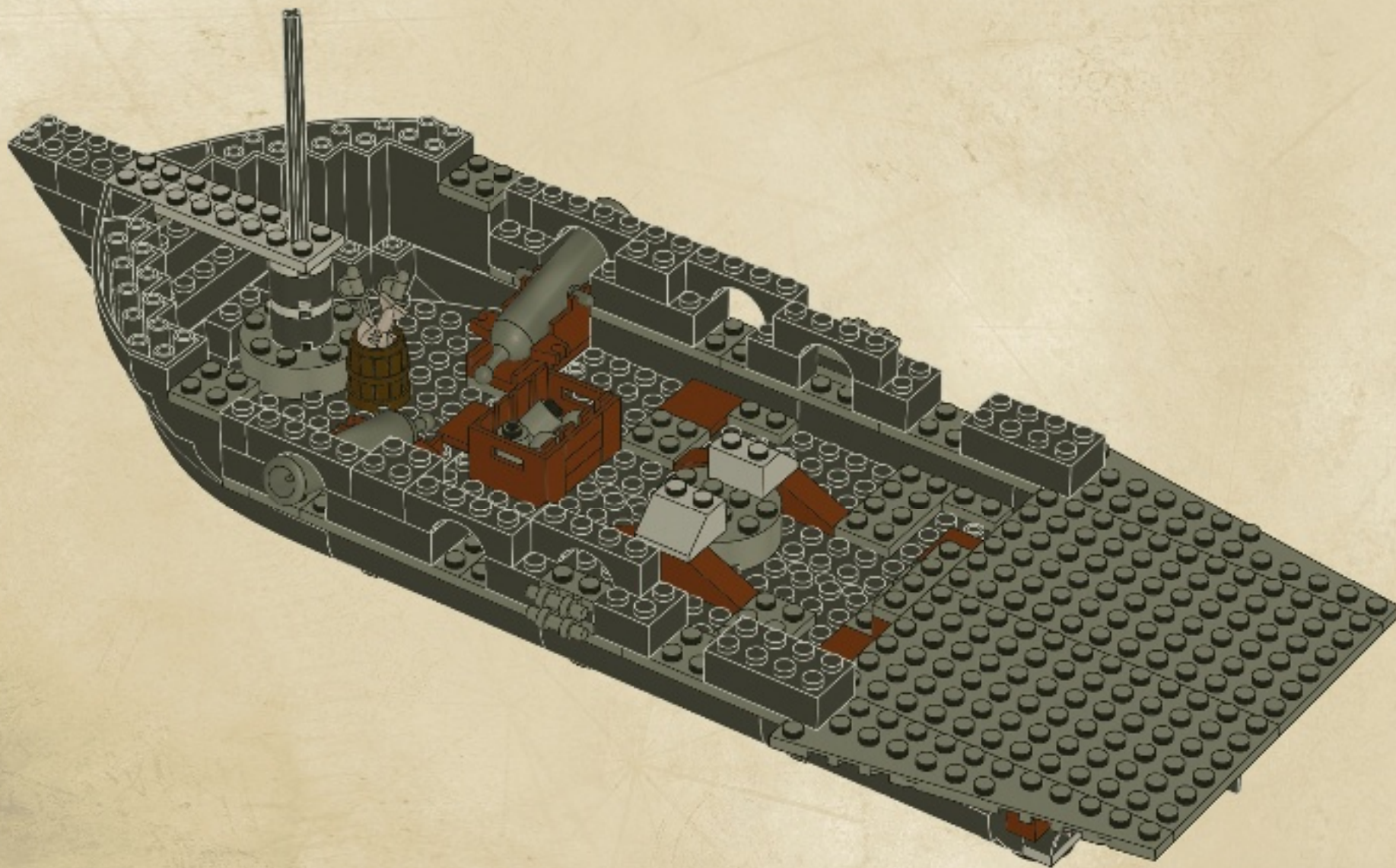





30

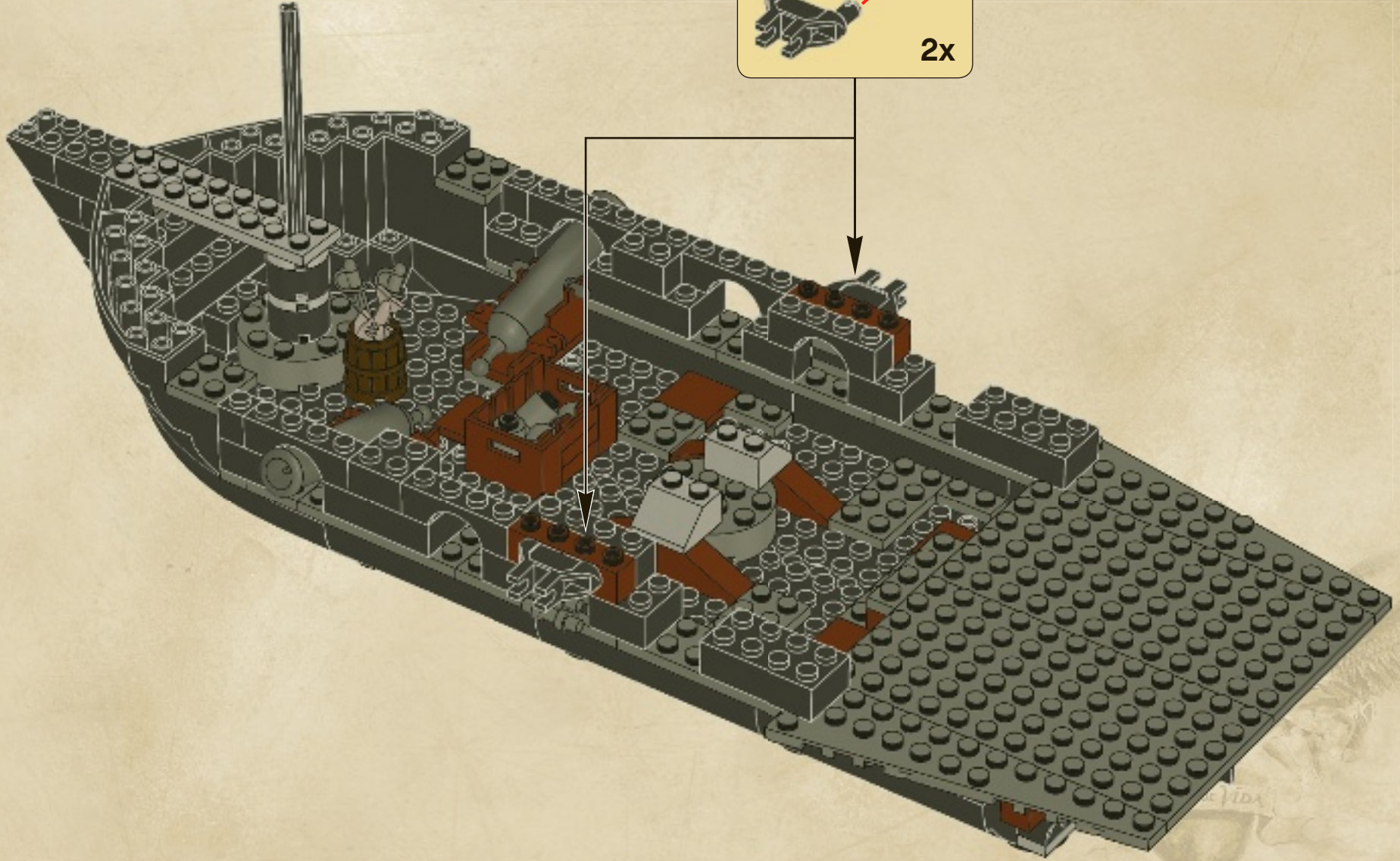
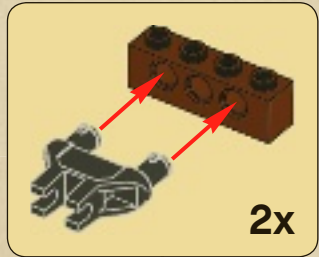



# 31

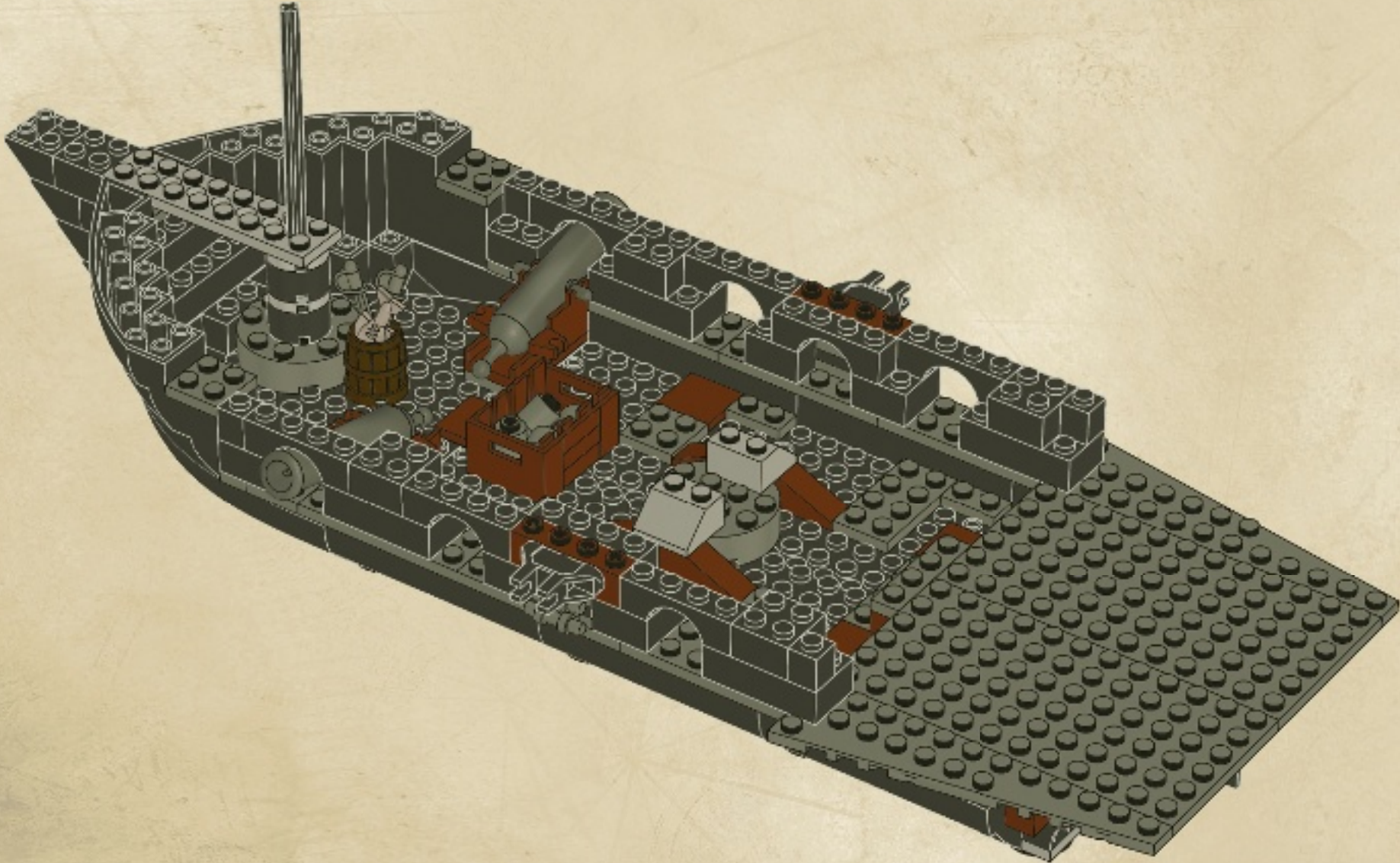

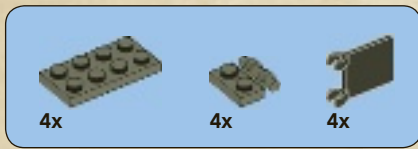

32

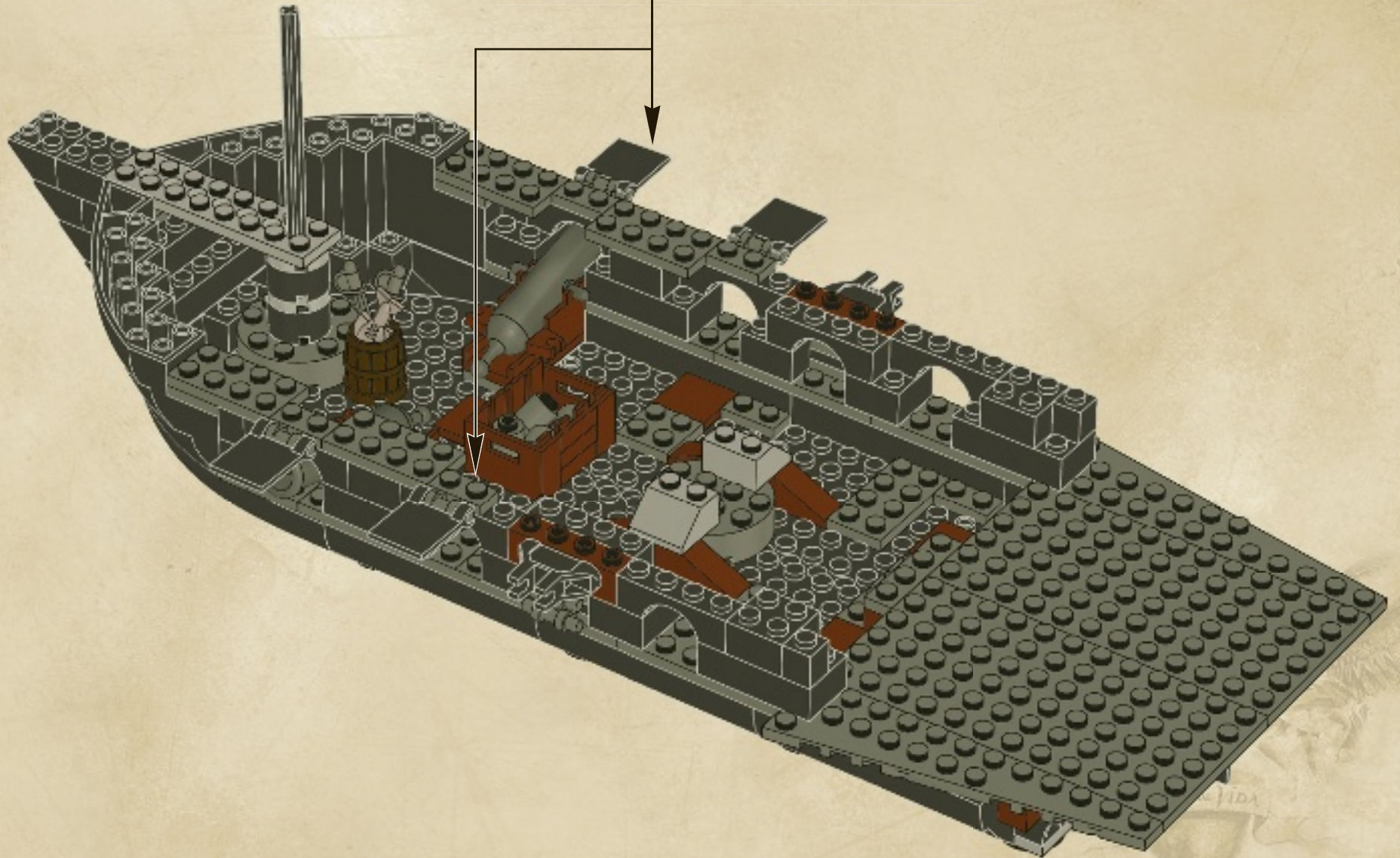
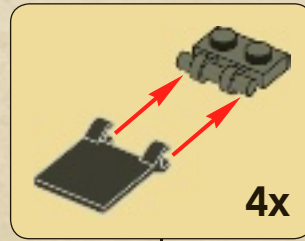

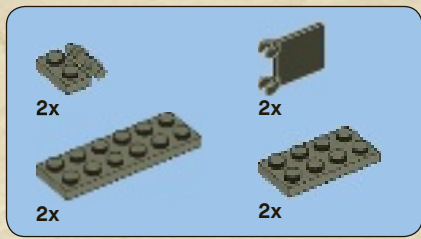

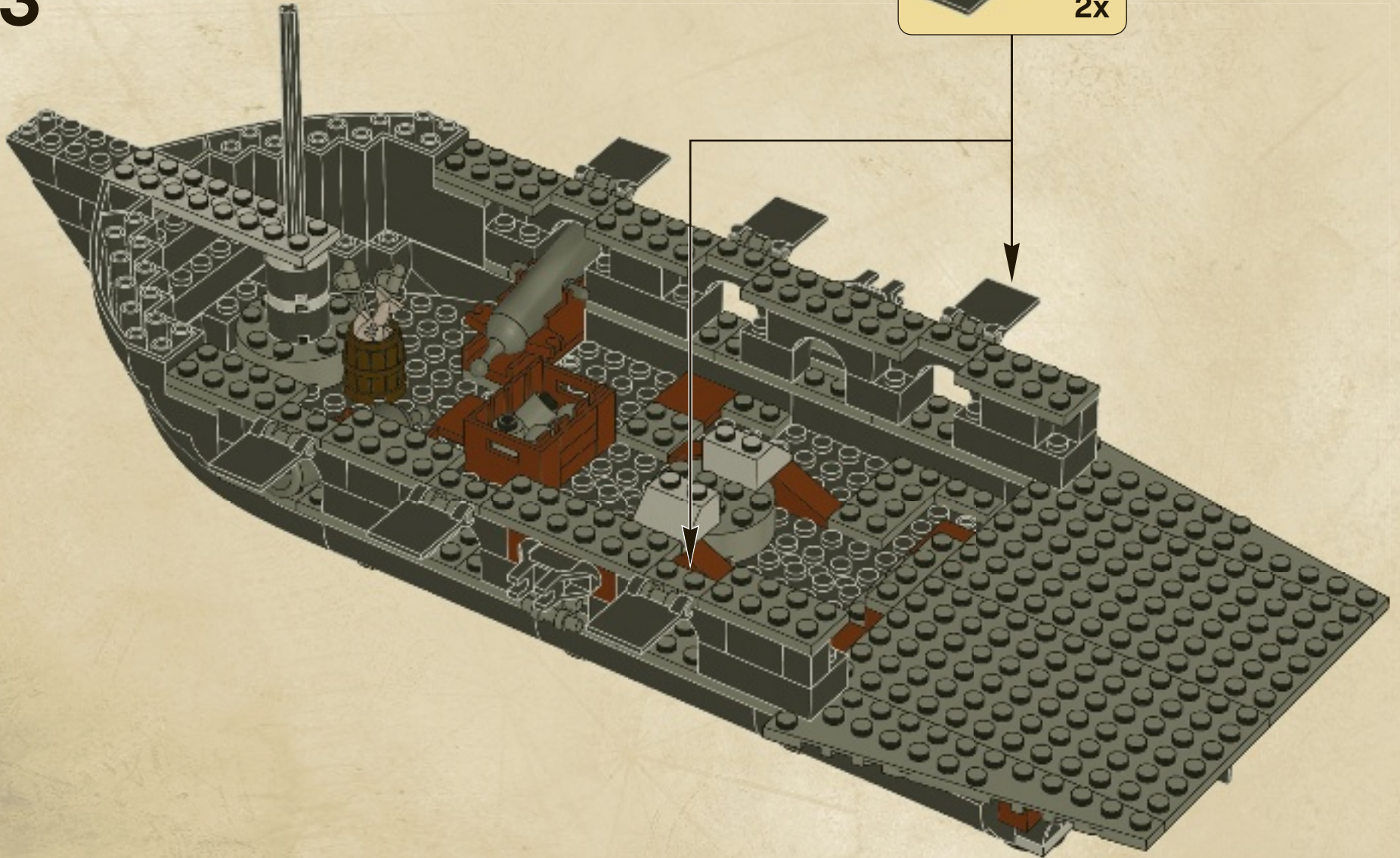
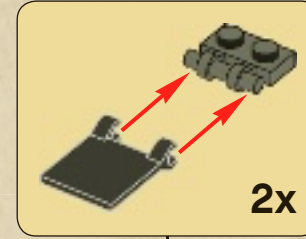

33

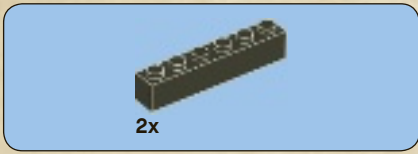

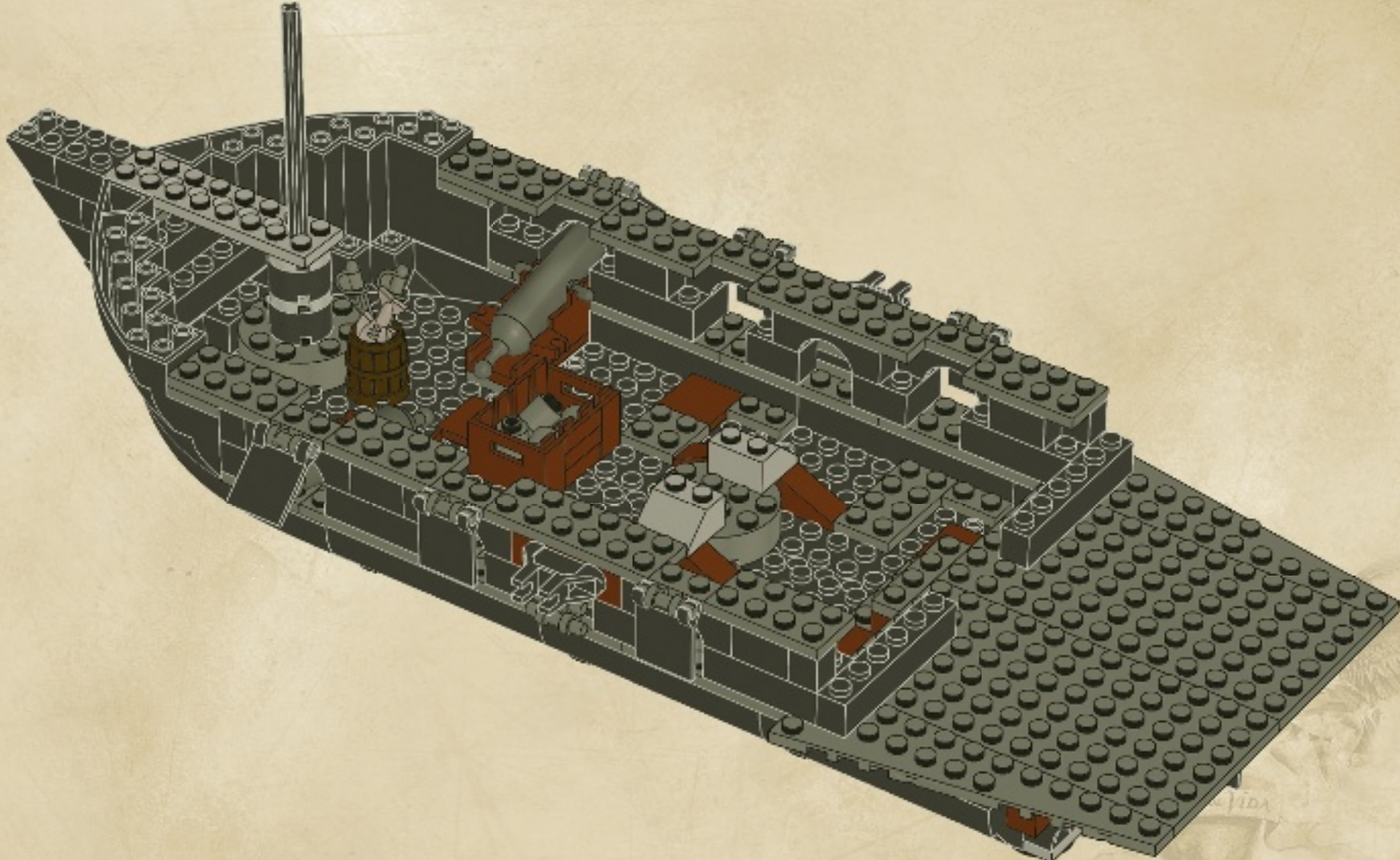

34



2x  4x 

# 35

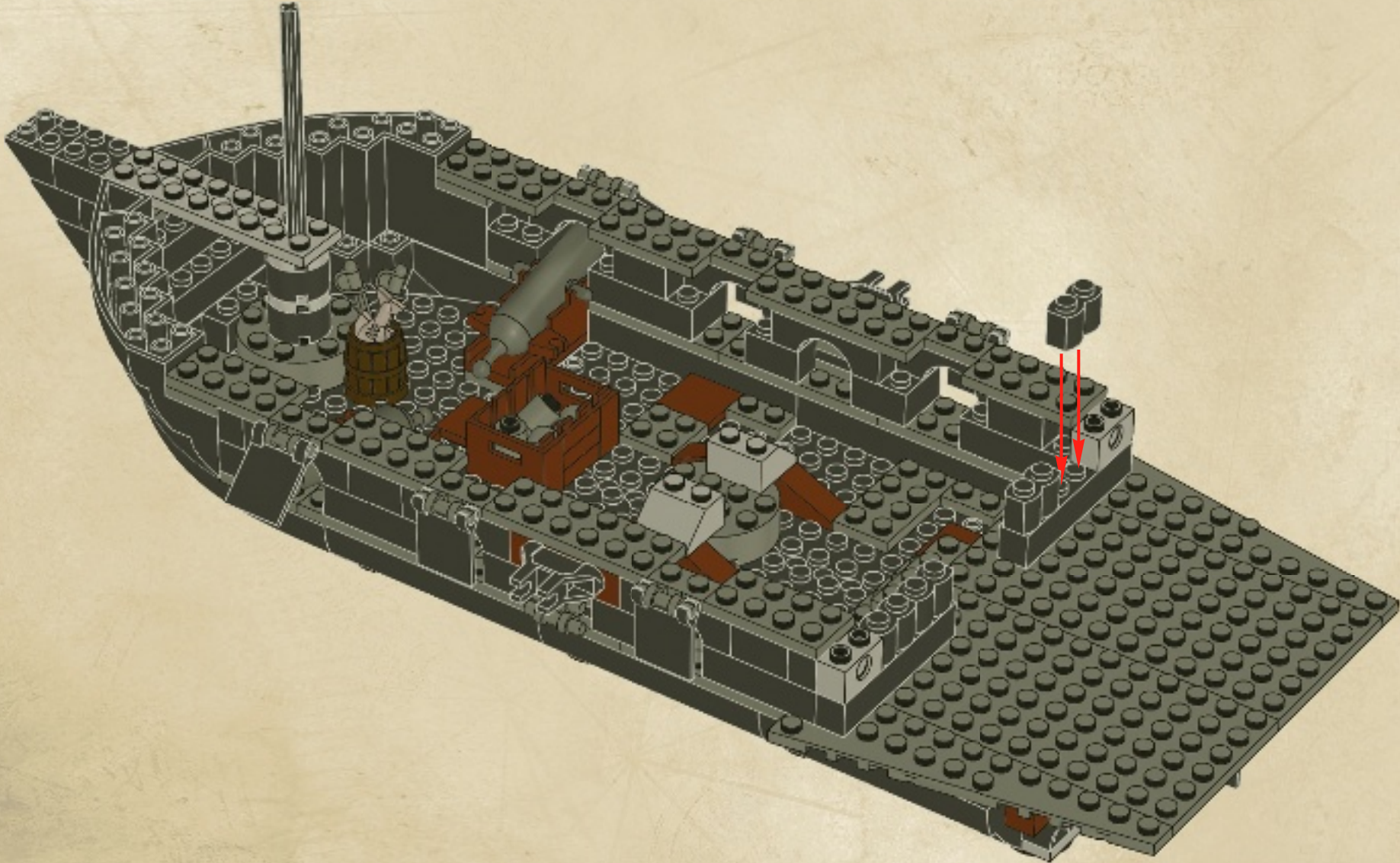



36

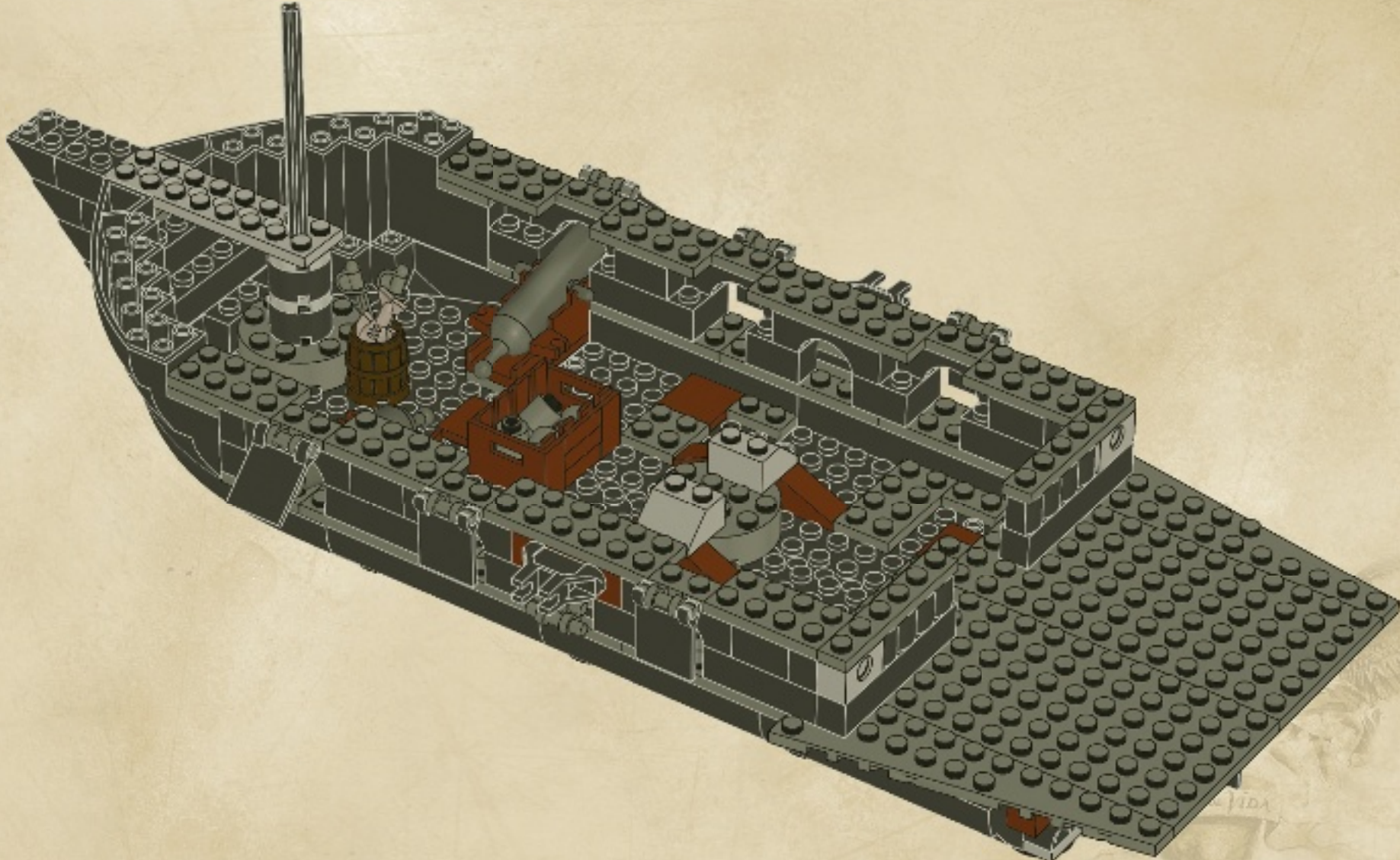

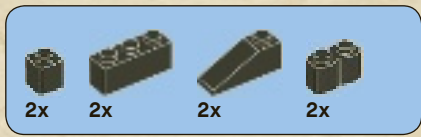

37

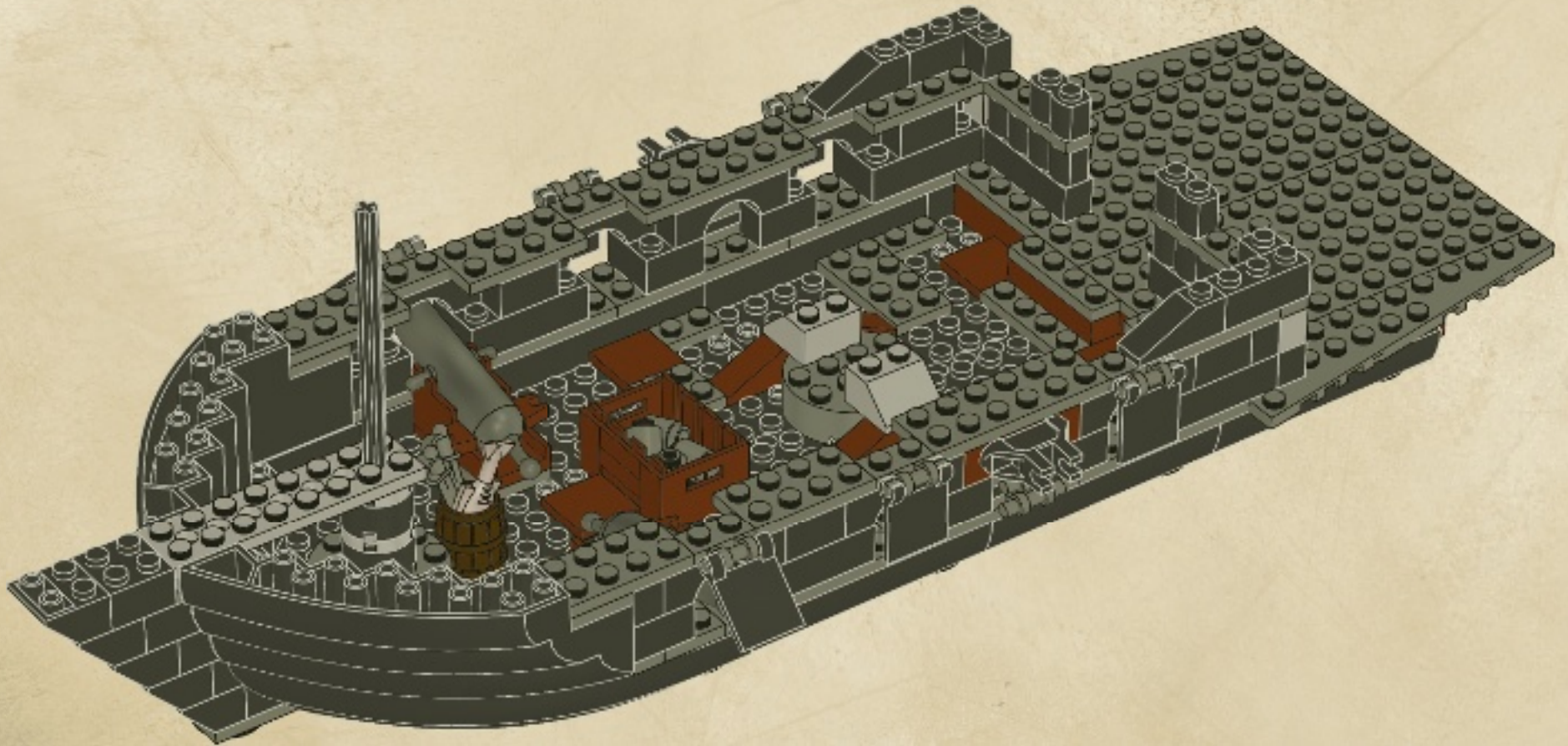





38

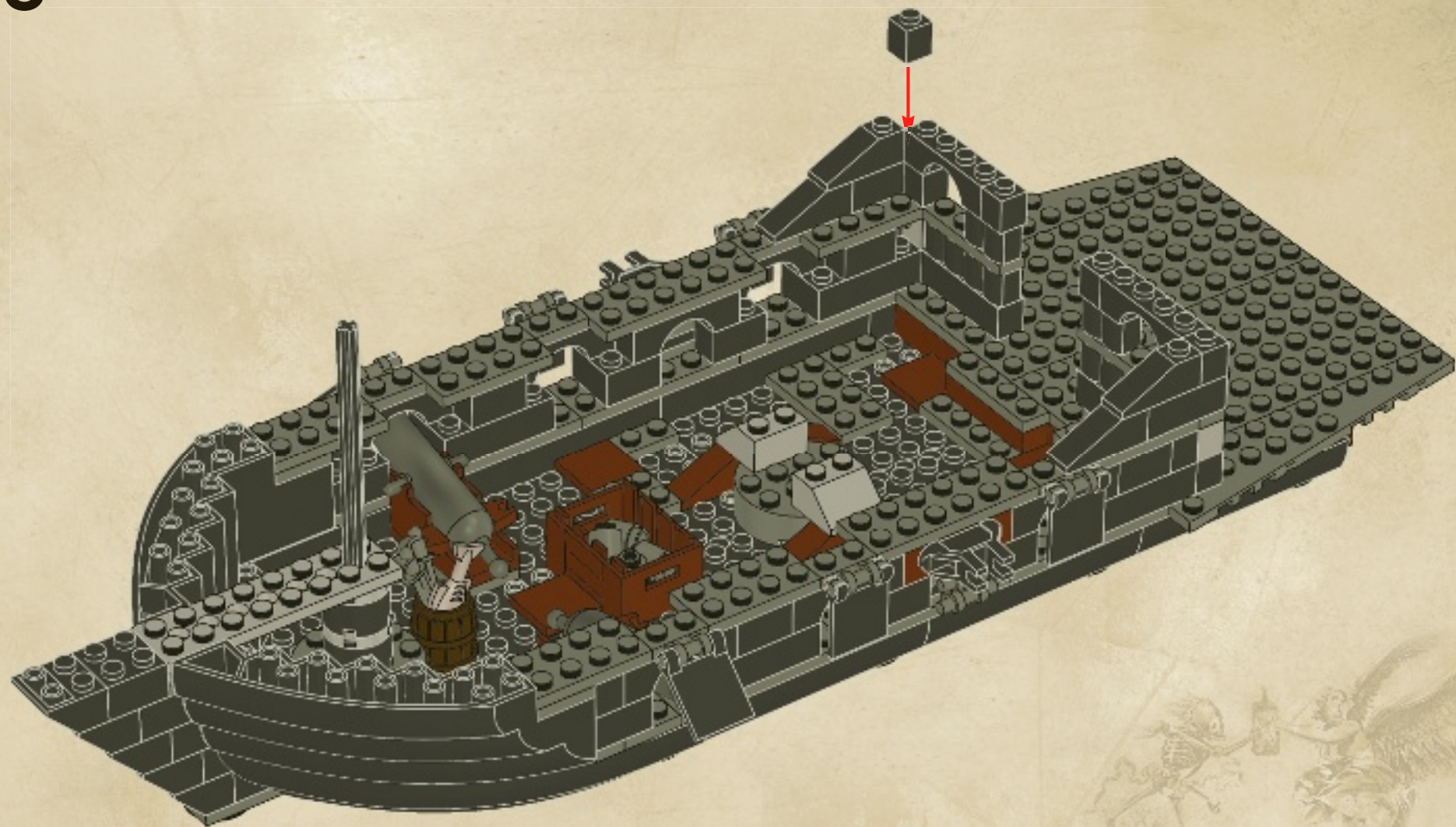



6x

39

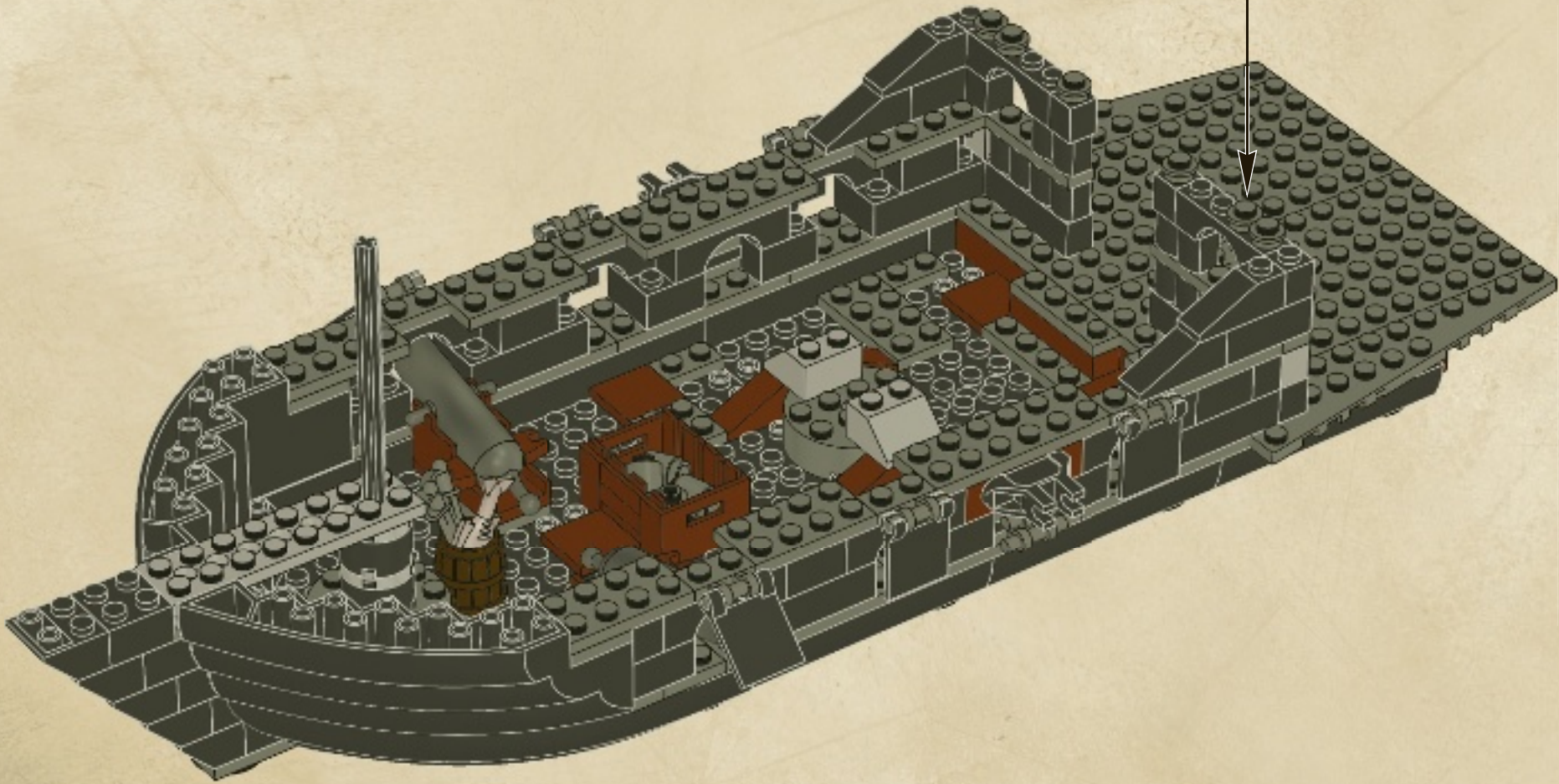

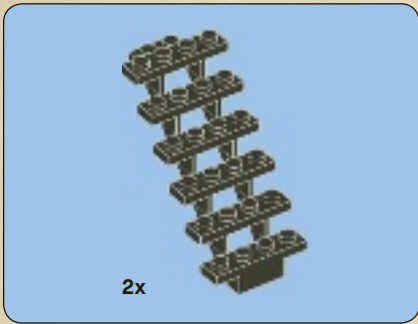

40





41

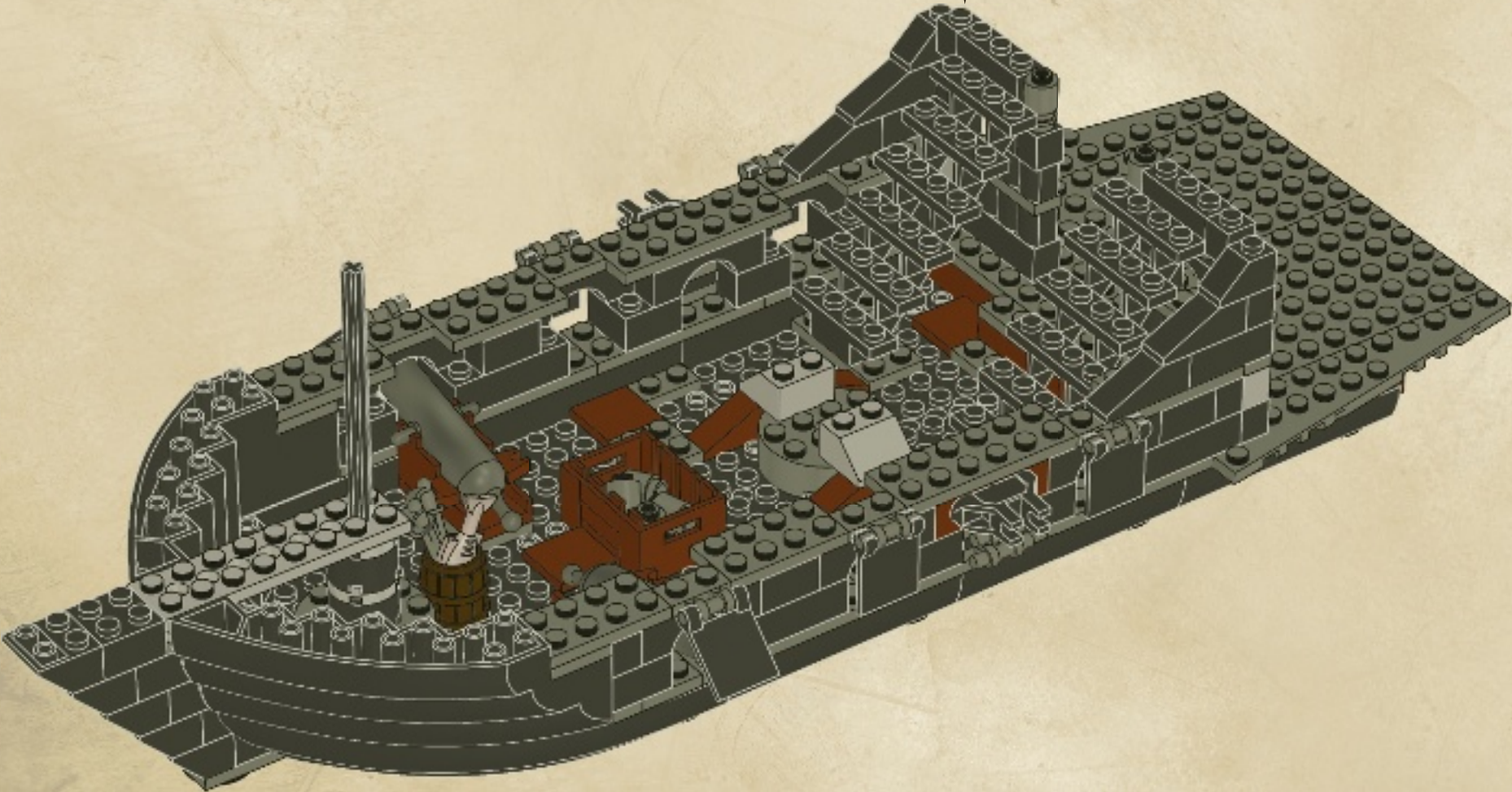

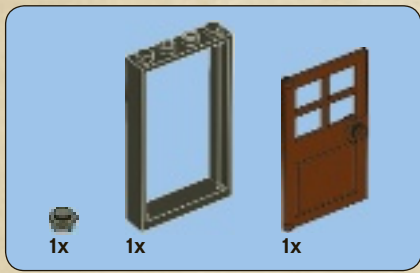

42

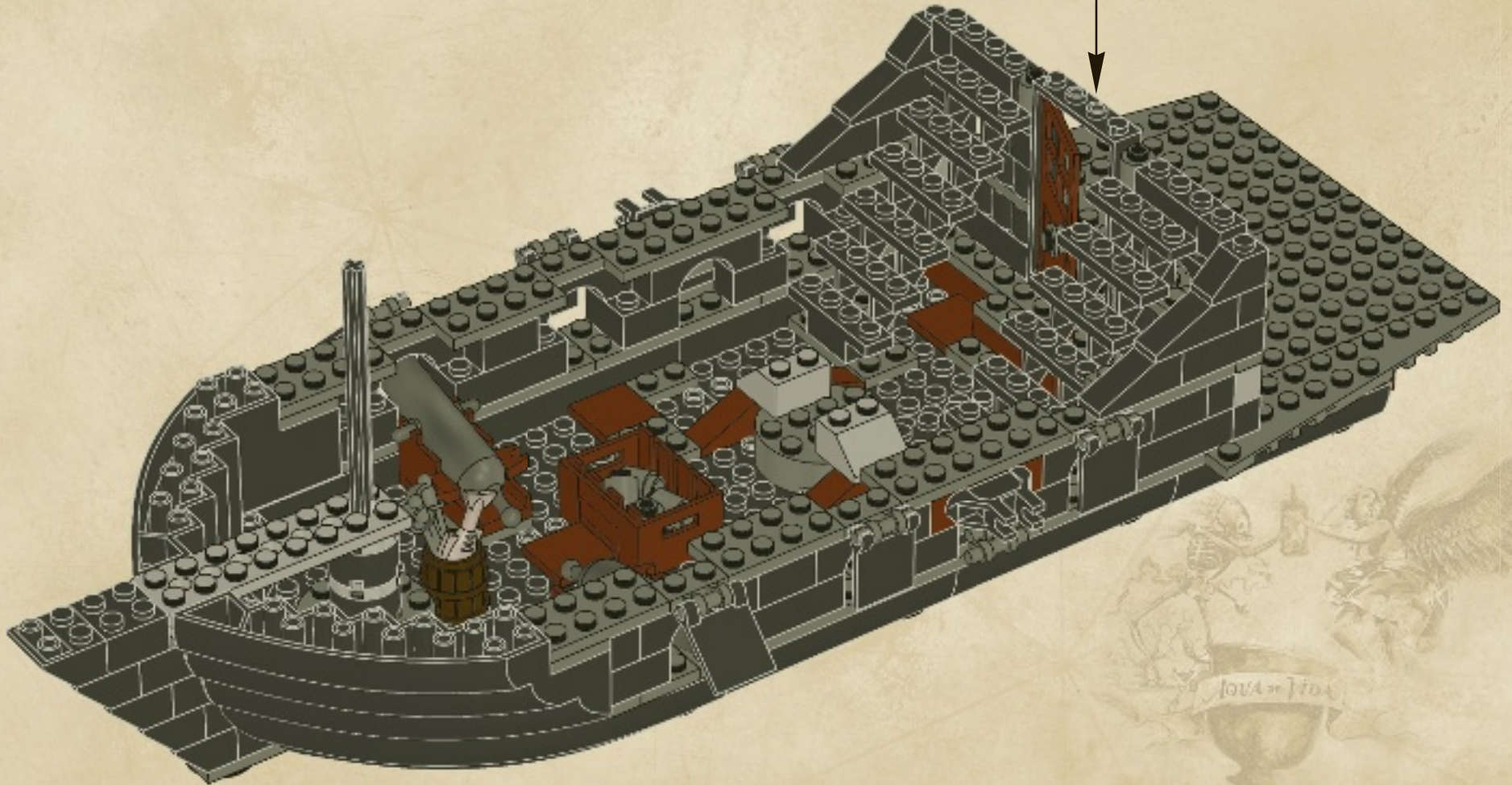
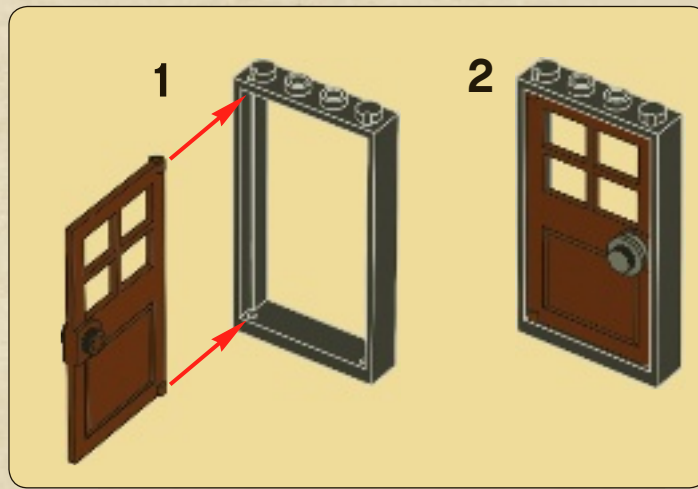

2x 4x 2x

43

2x

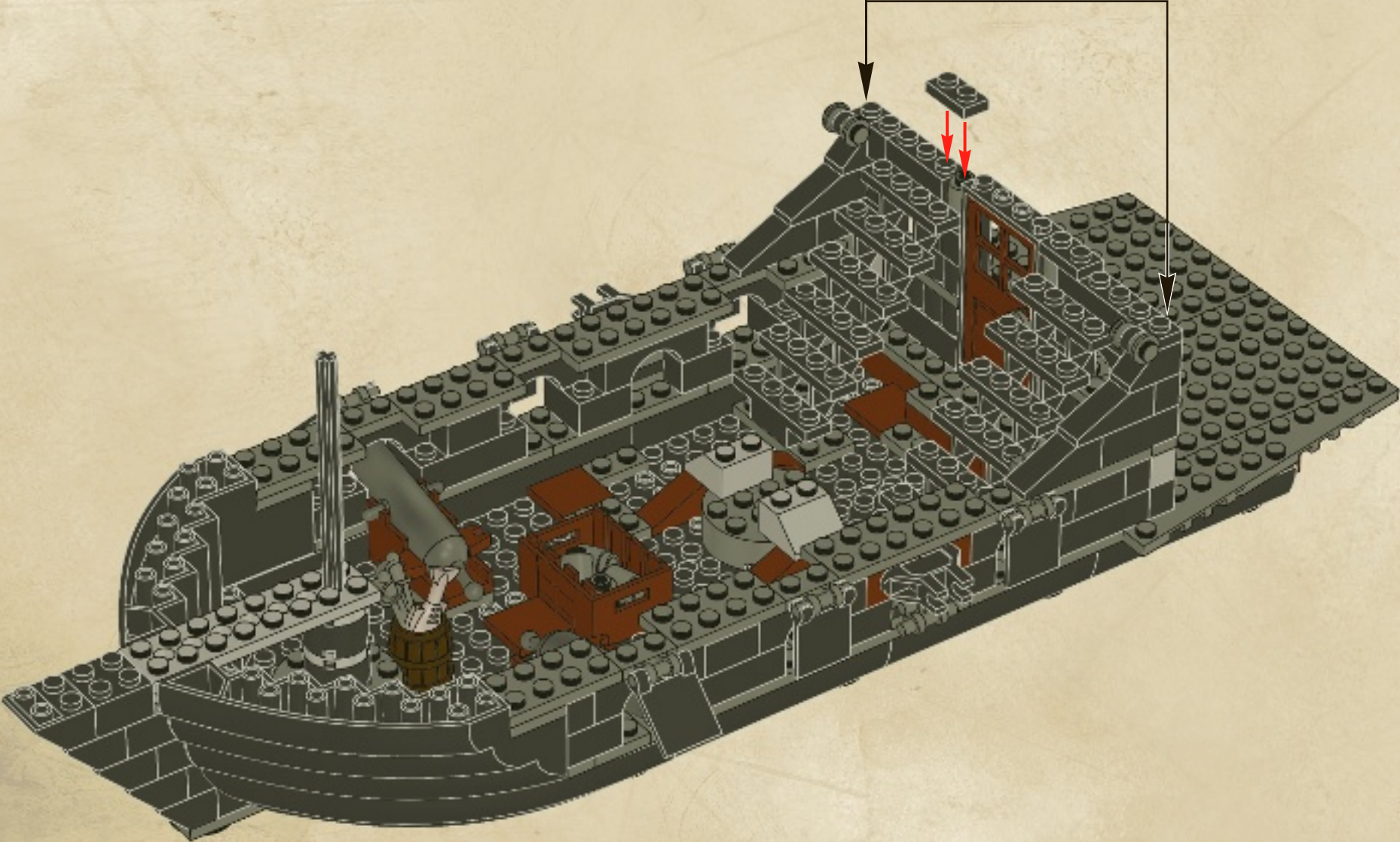



2x

44

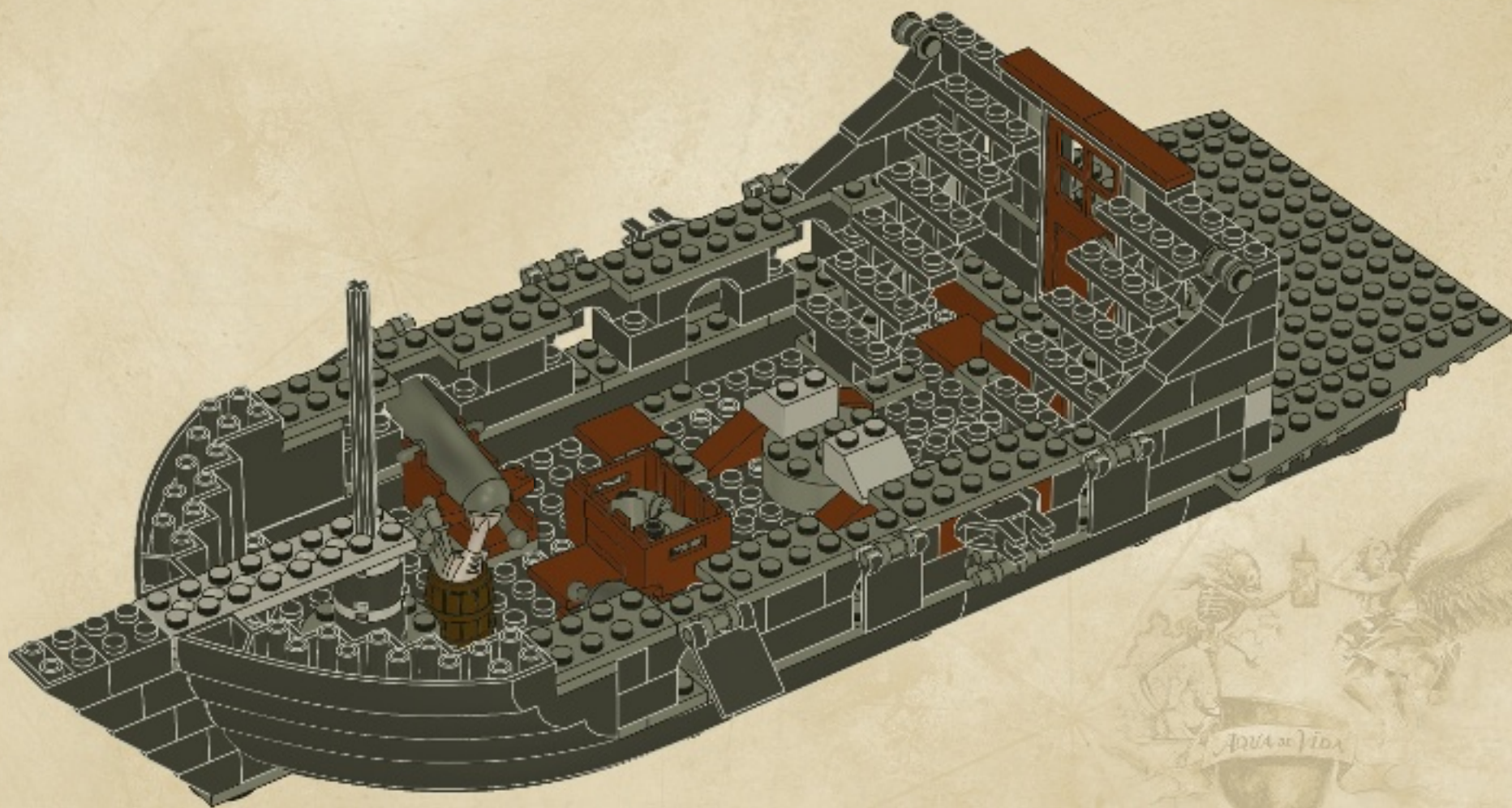

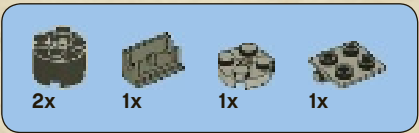

# 45

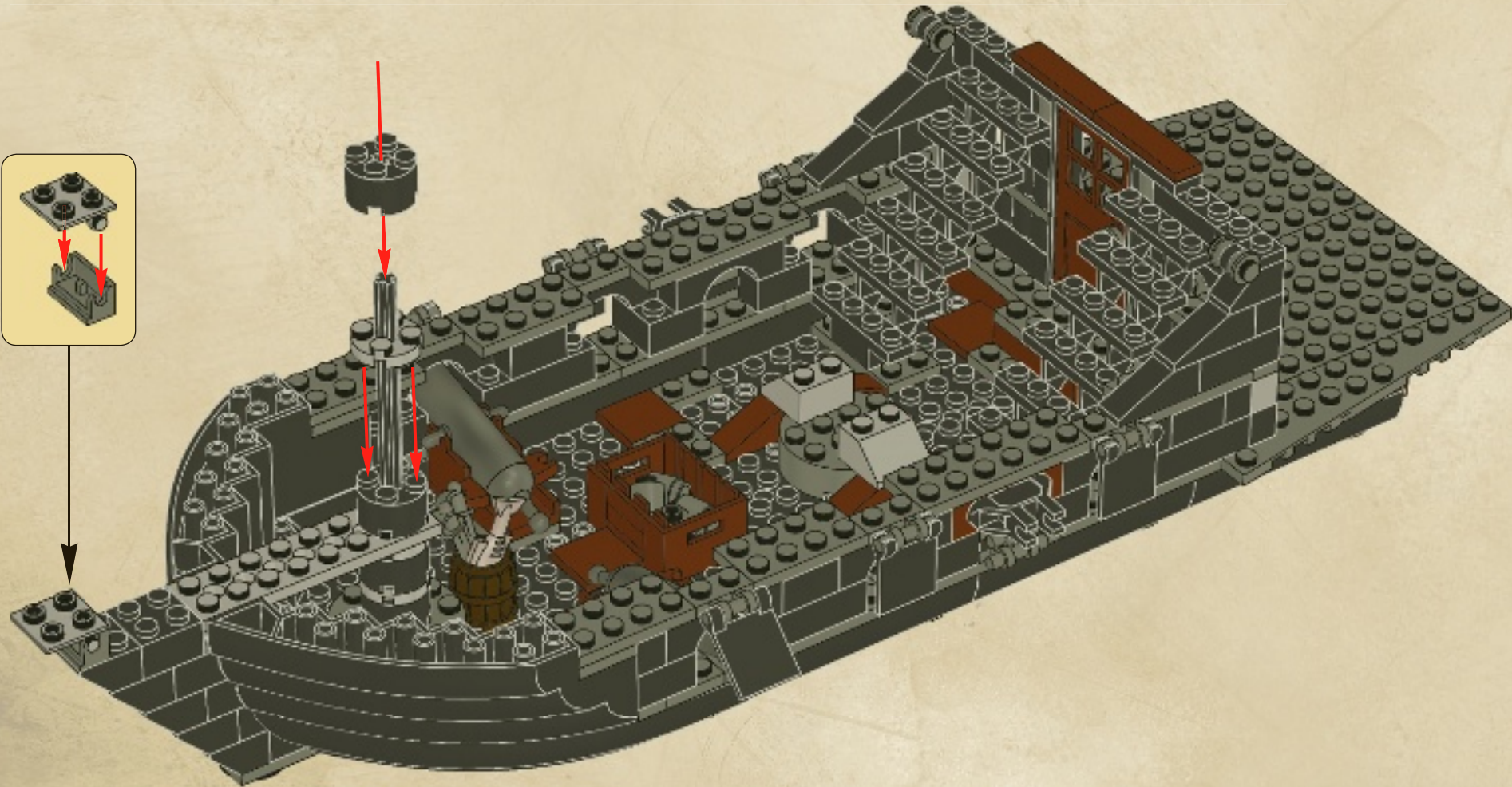





46

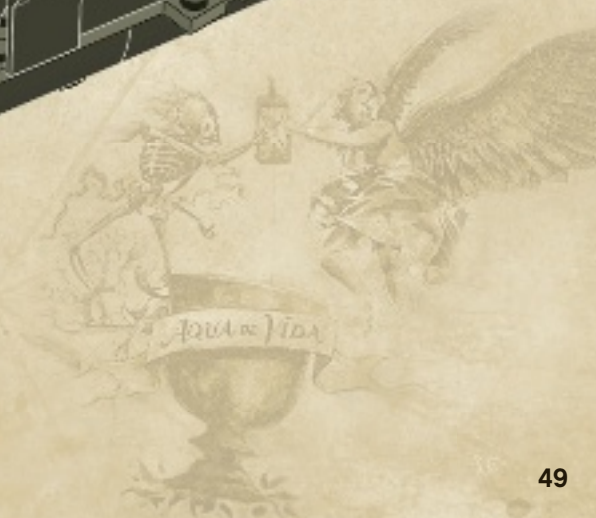
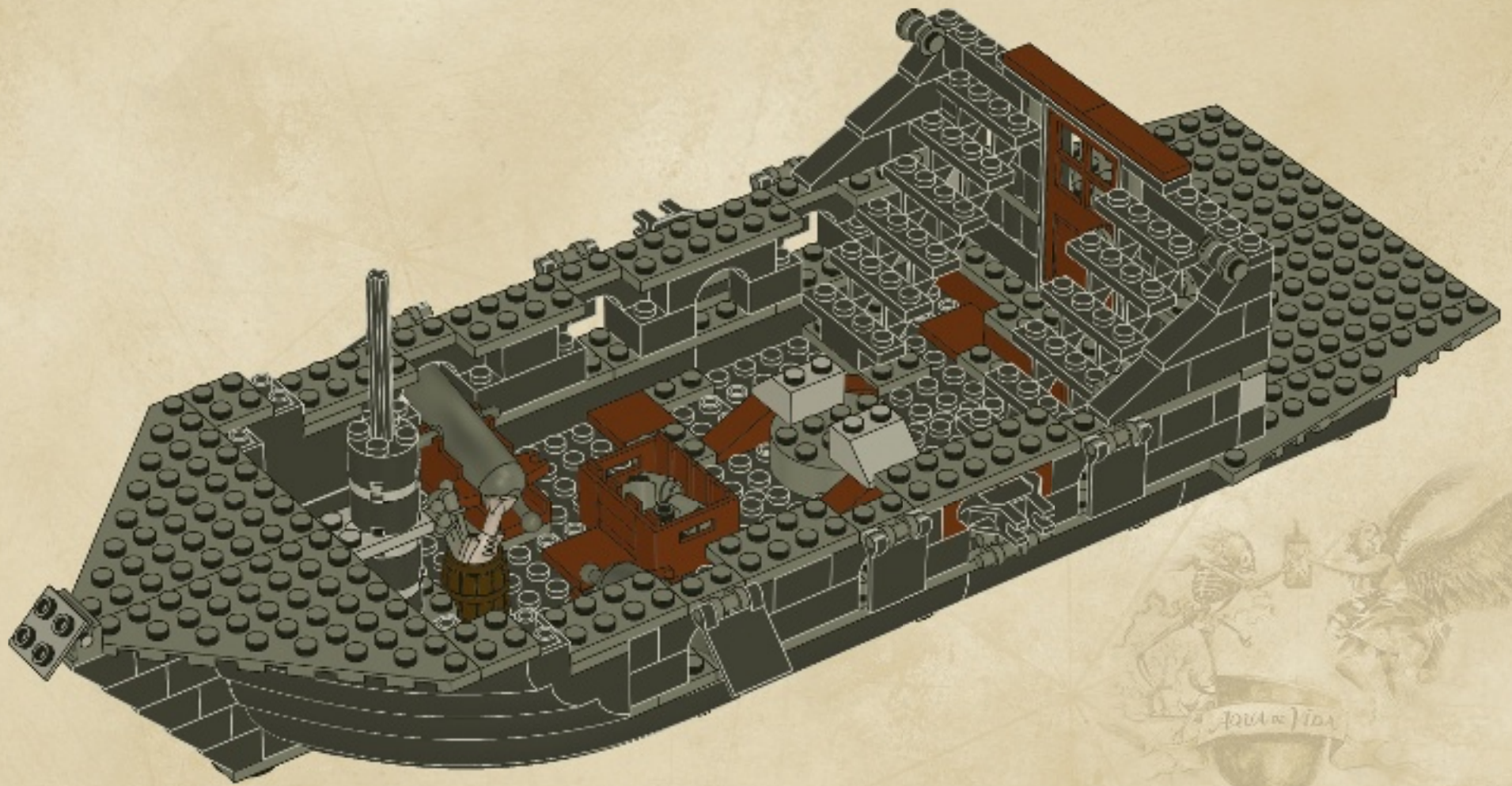



2x



4x



1x

# 47

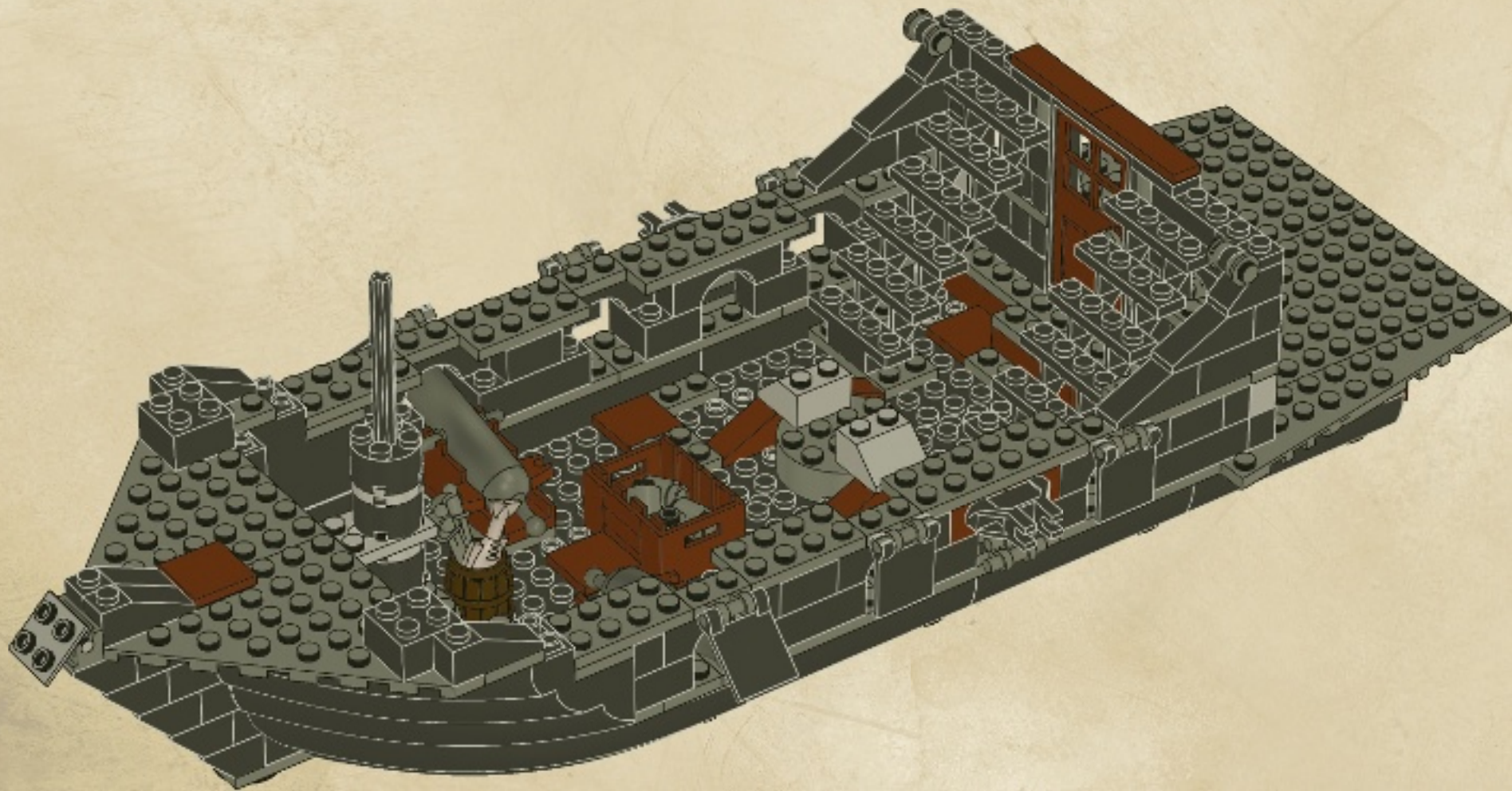



# 48

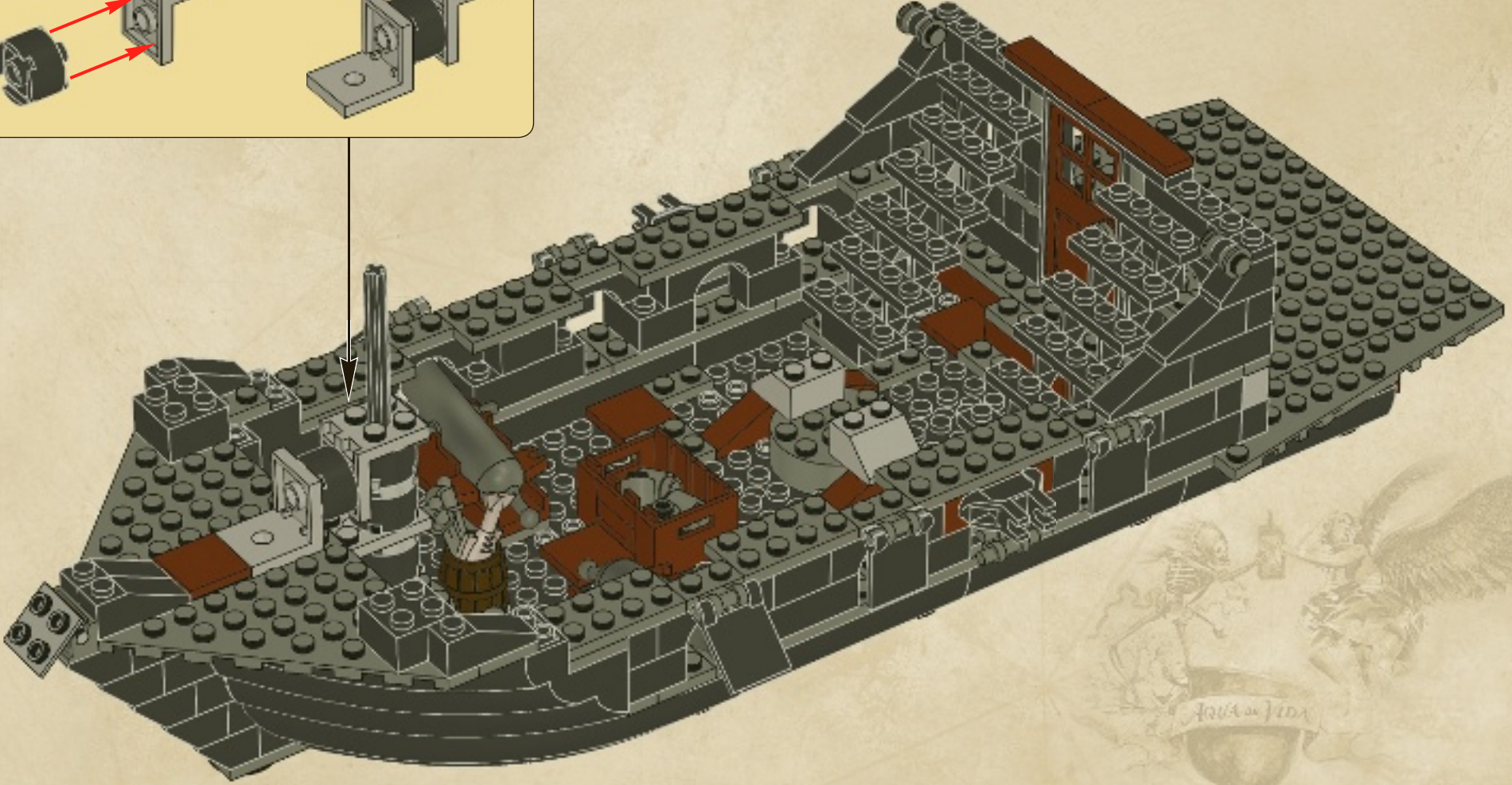
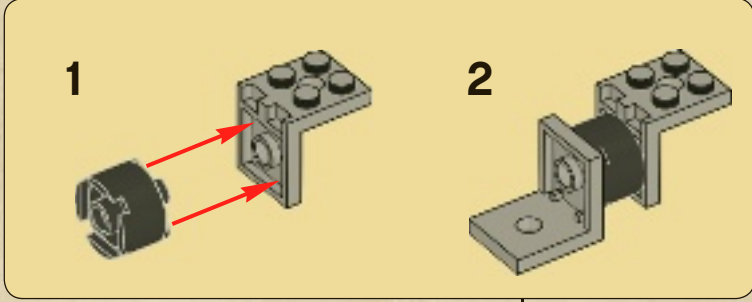

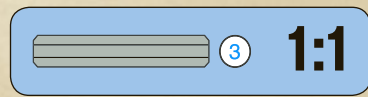
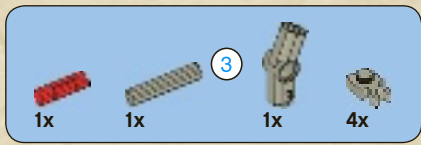

49

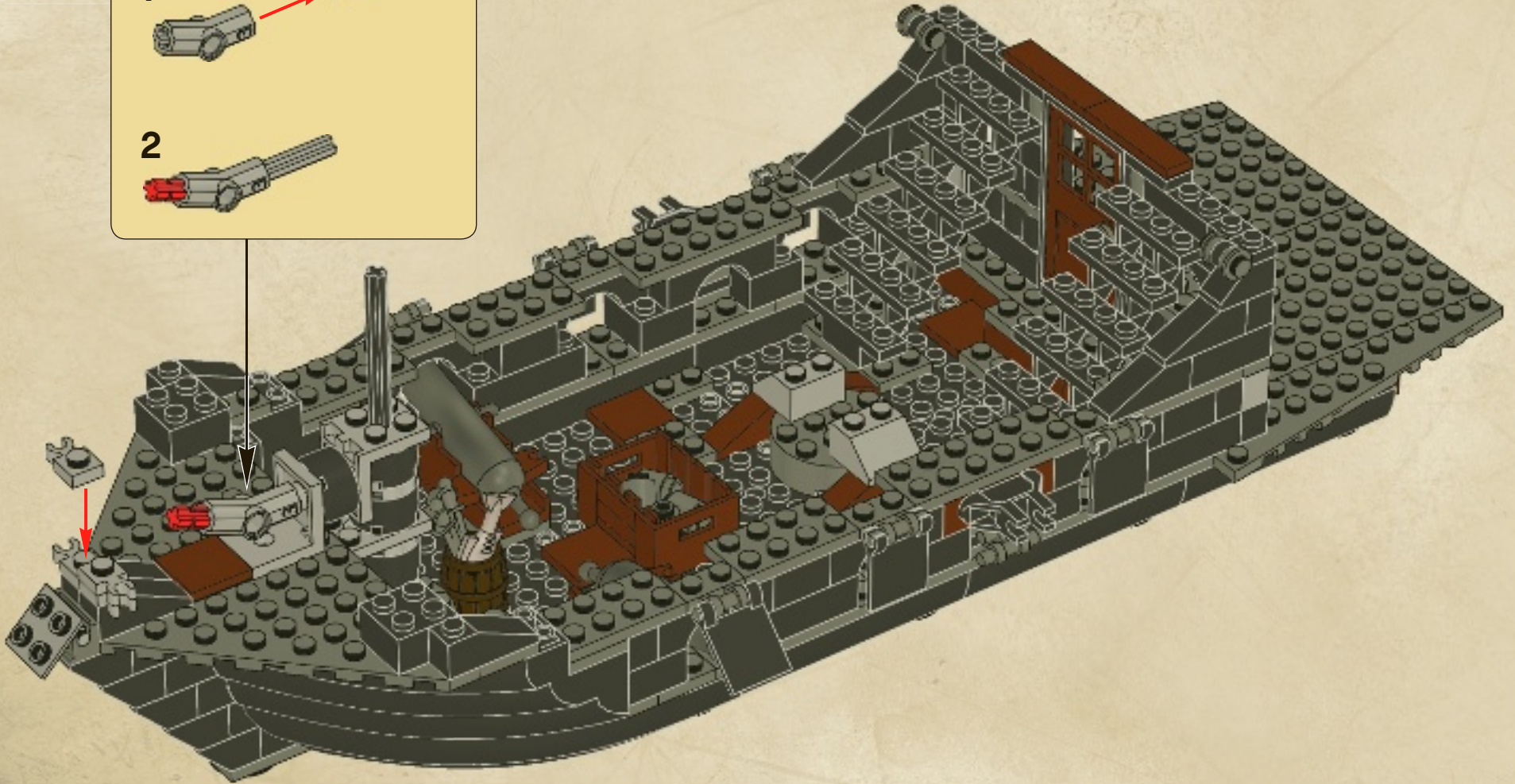
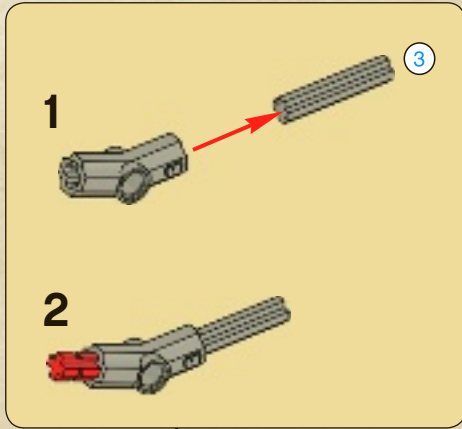

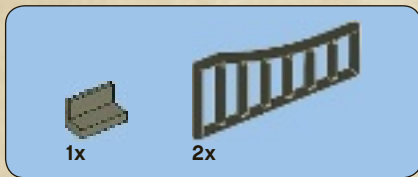

50

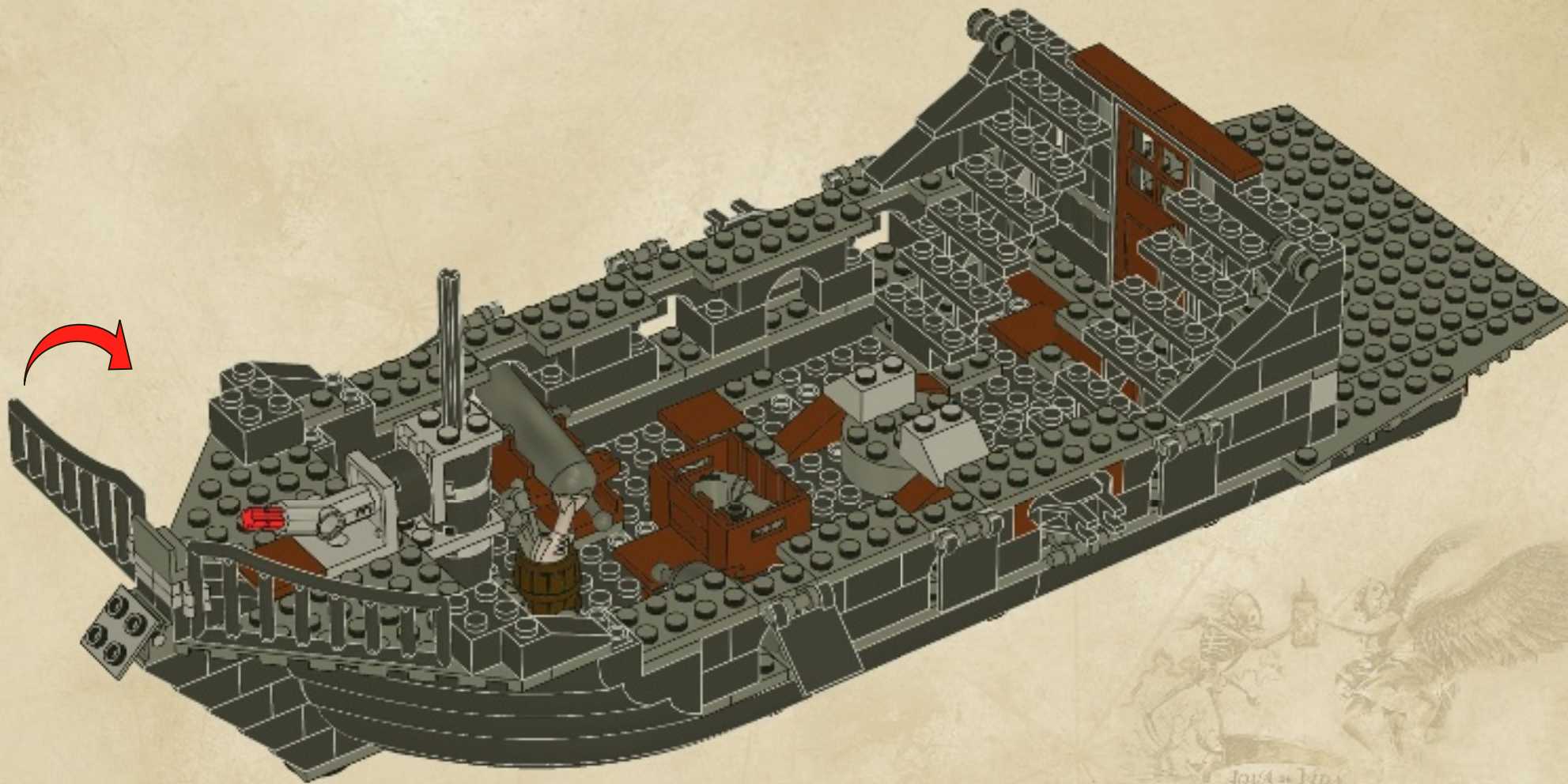

4x

4x

# 51

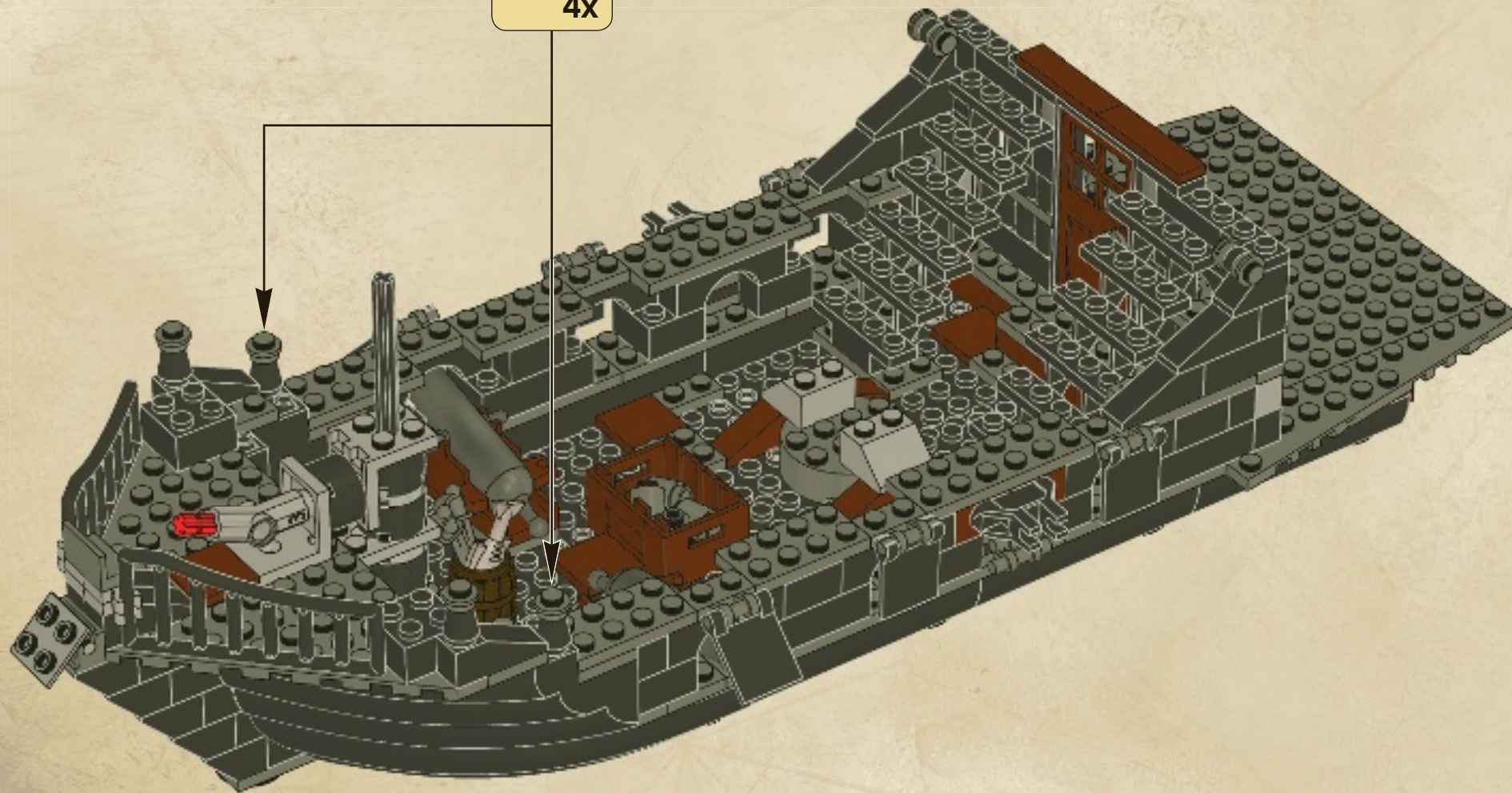
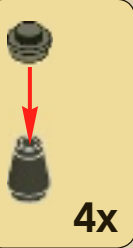

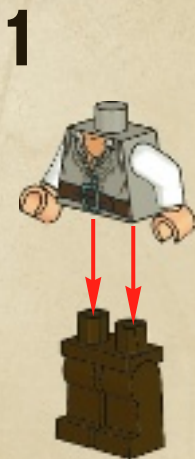
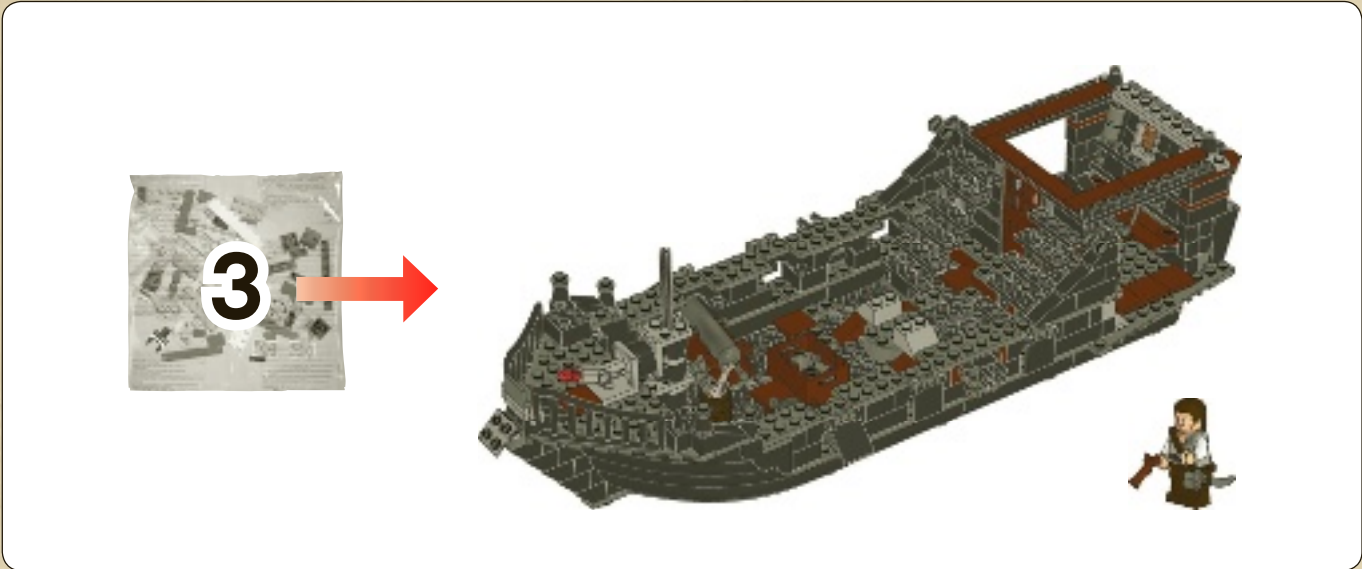

2x 6x 2x

# 52

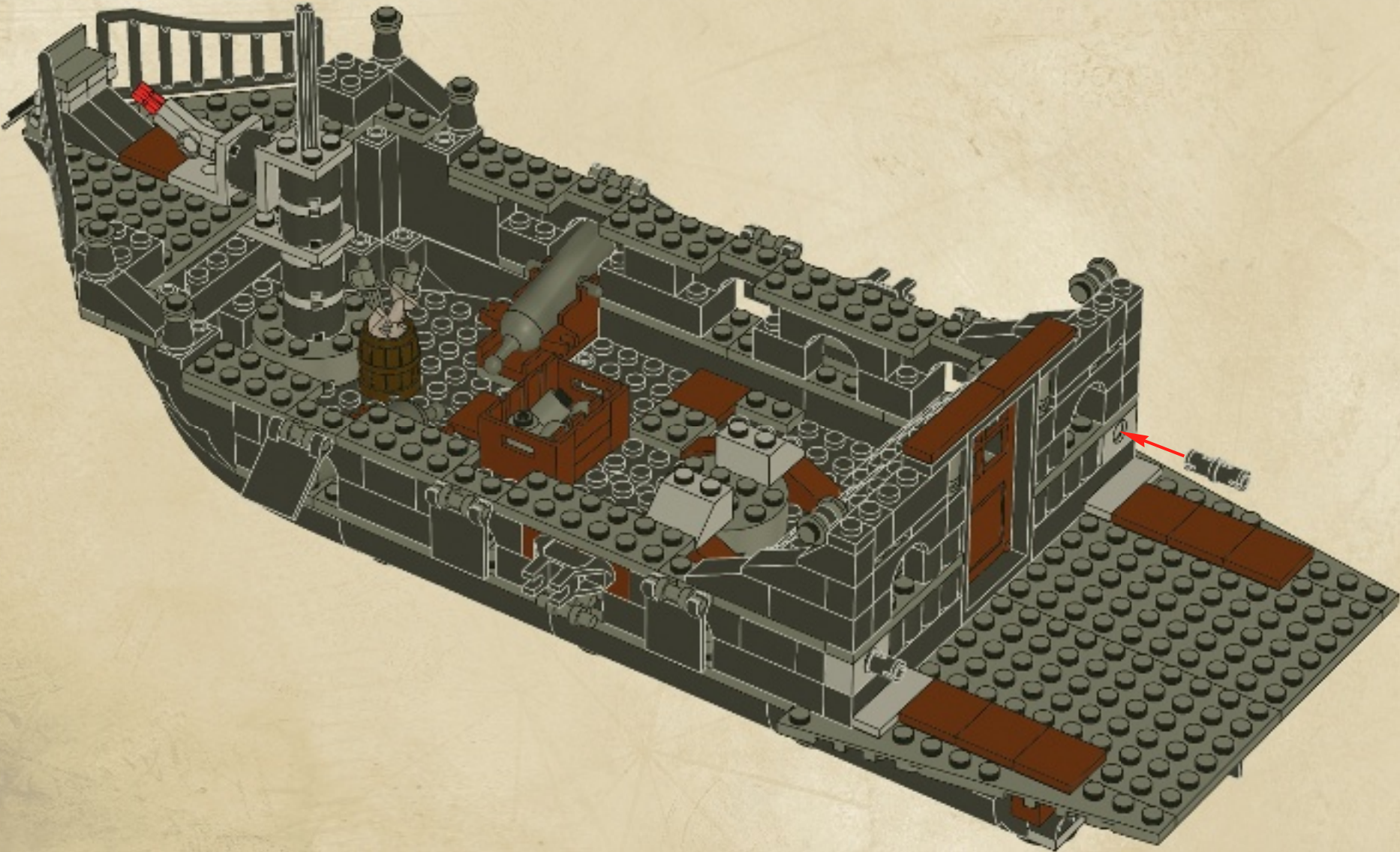





53

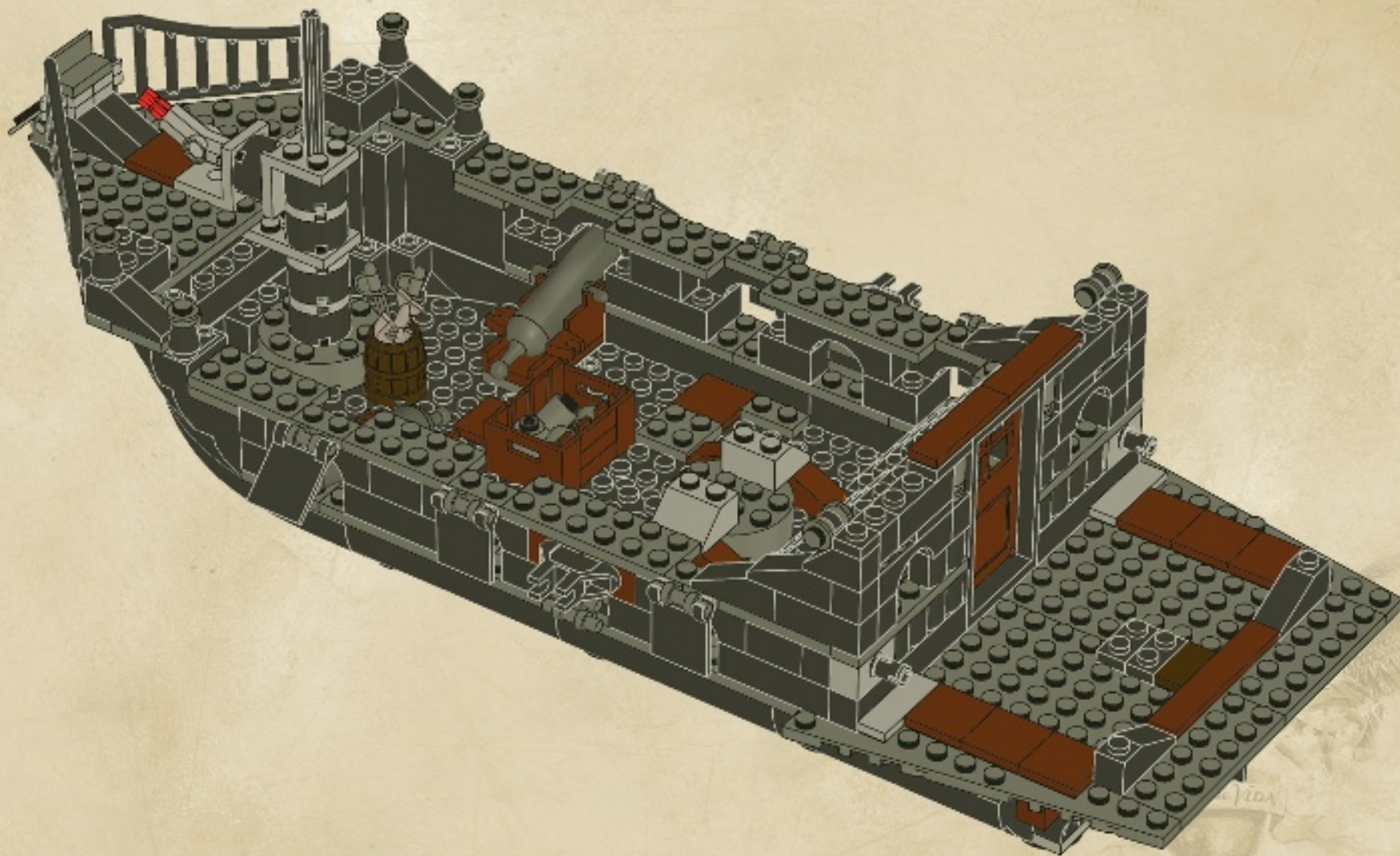

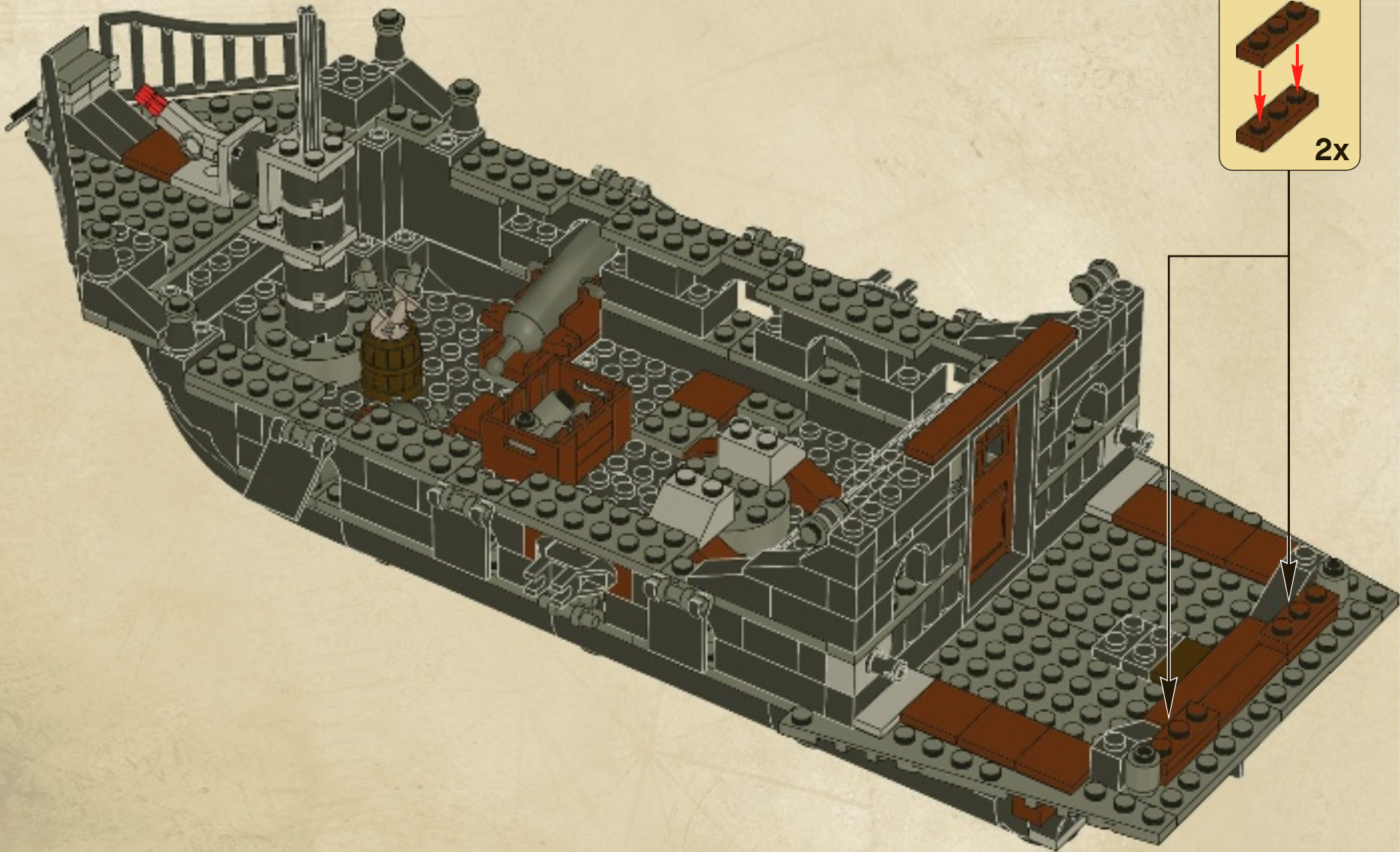

2x 4x 1x

# 54



2x

2x  3x 

55

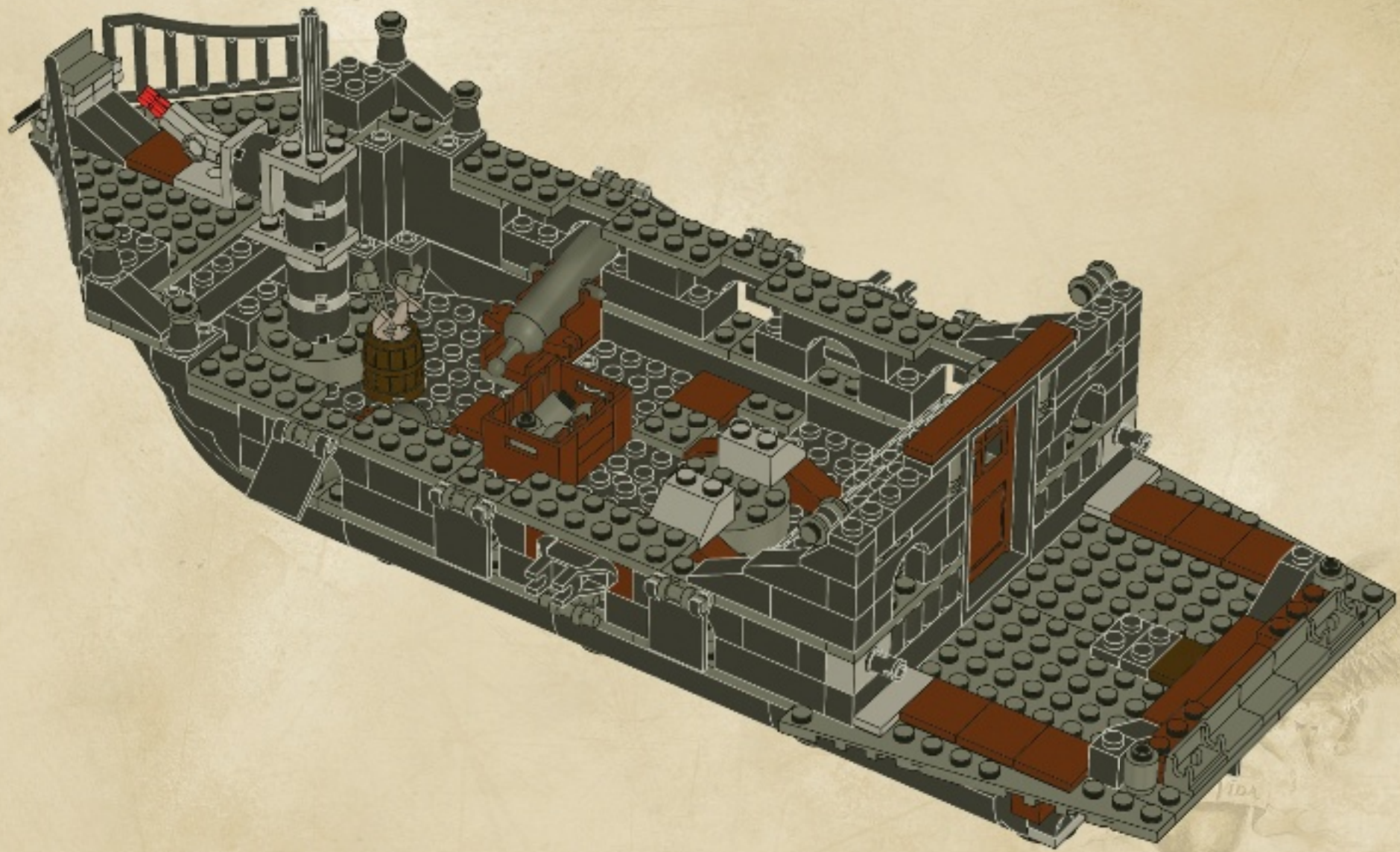

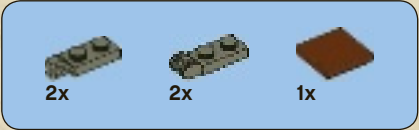

56

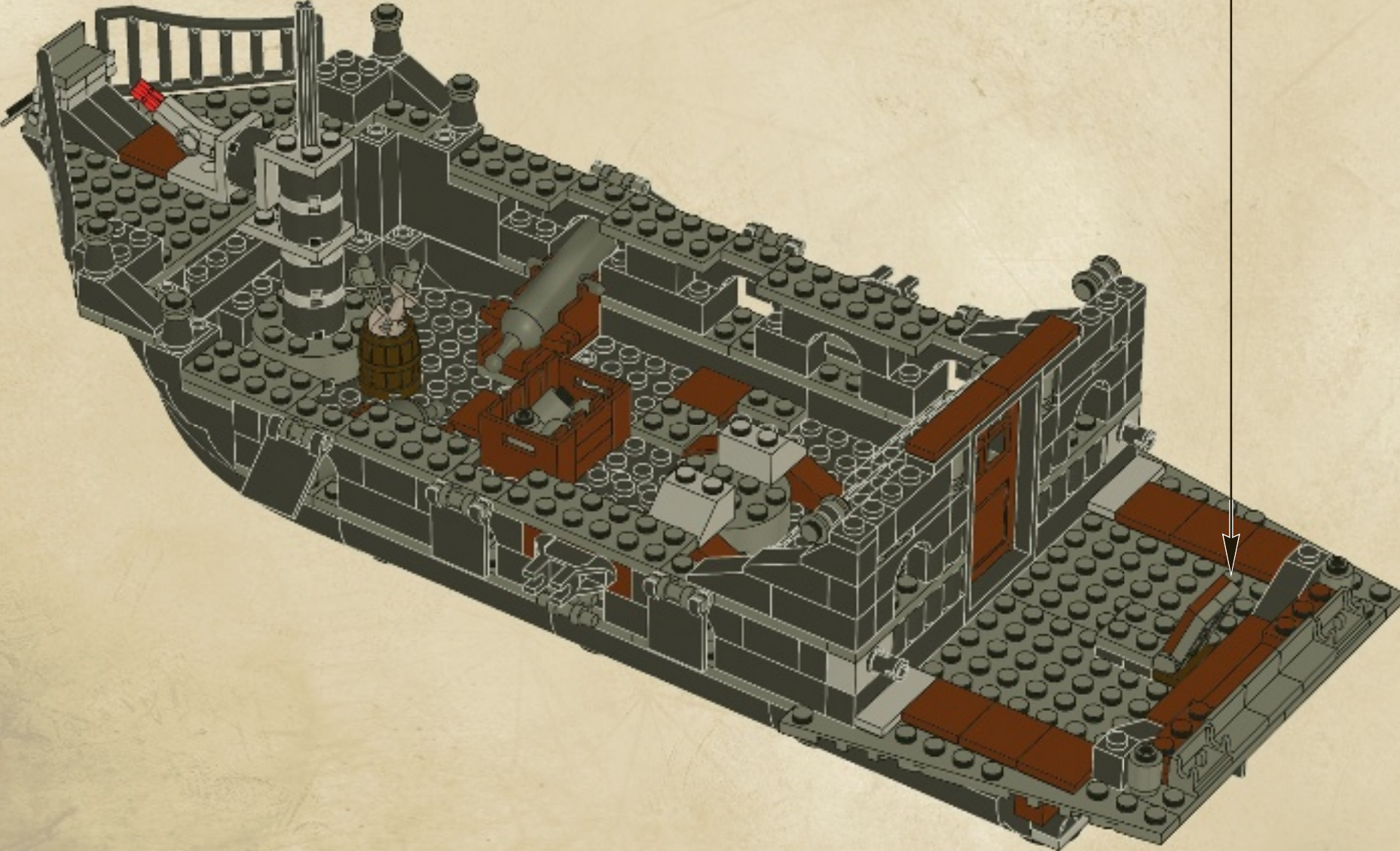
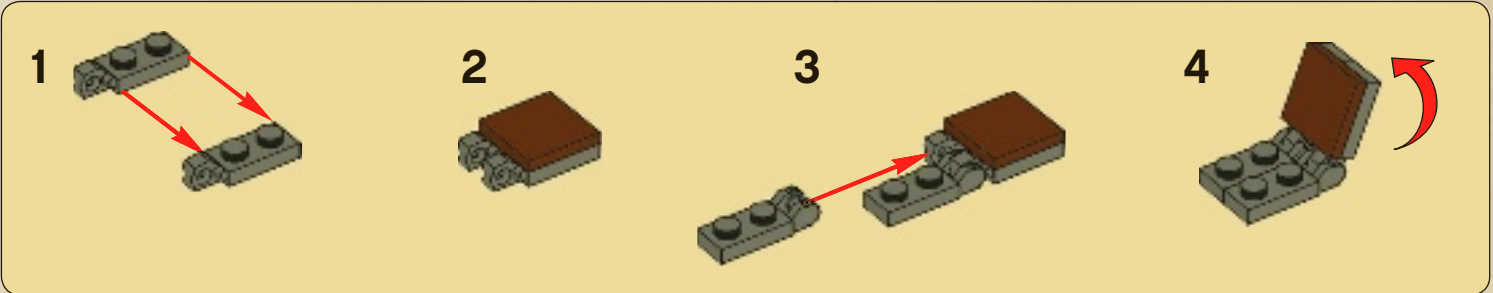



57

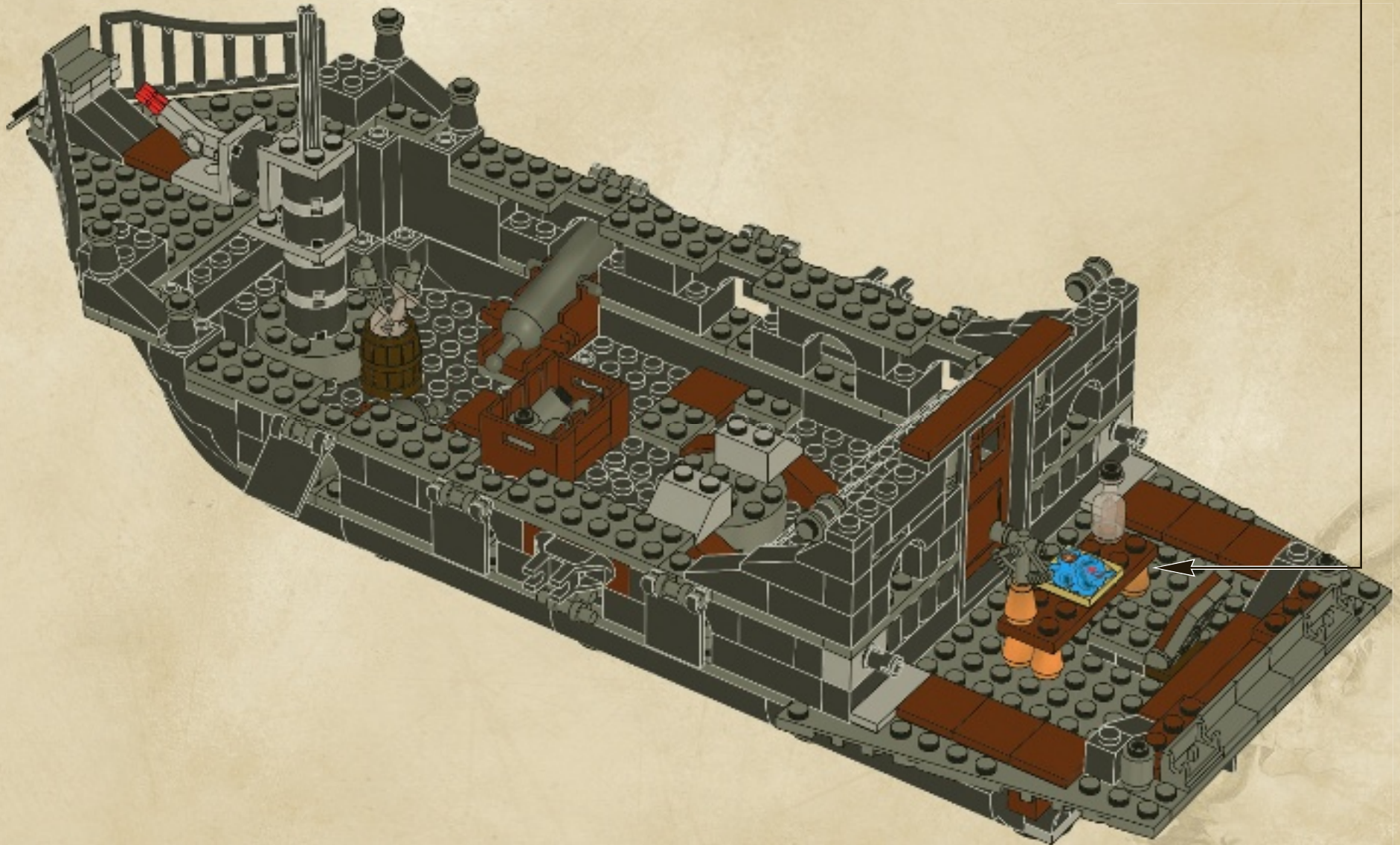
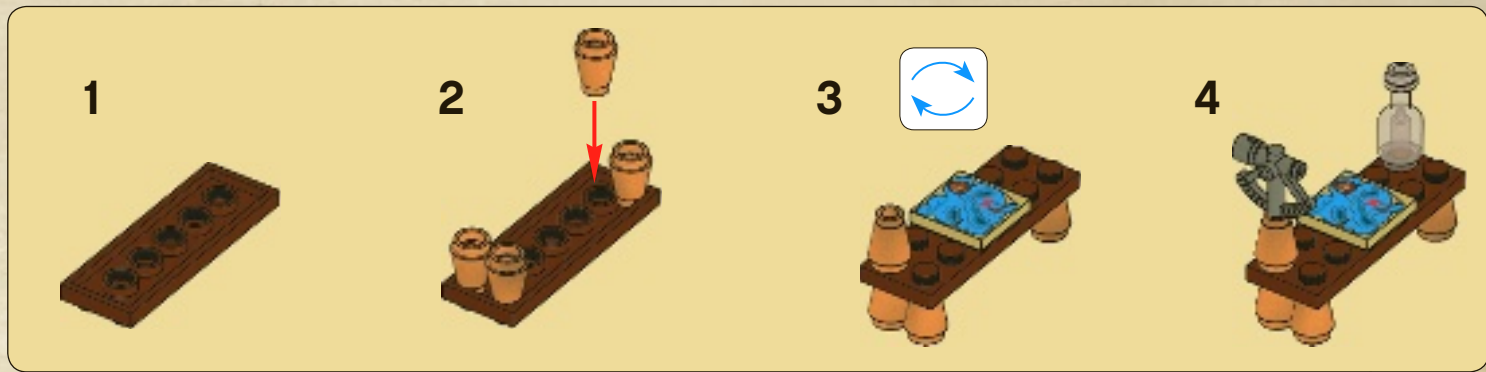

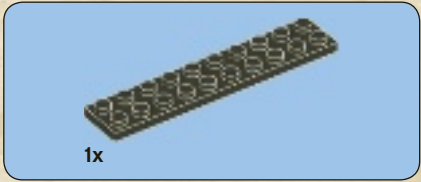

1x

1

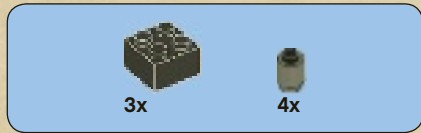

3x

4x

2

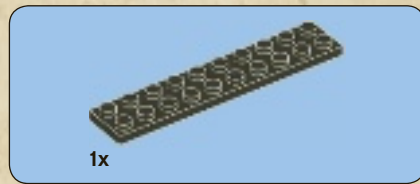
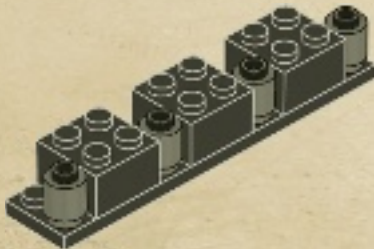

1x

3

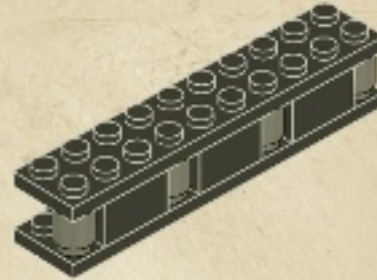

2x

3x

4

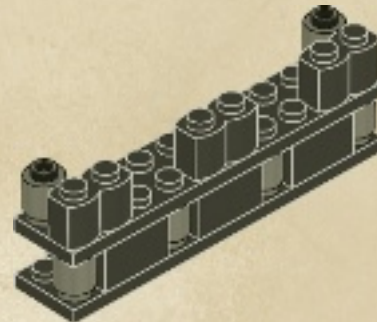

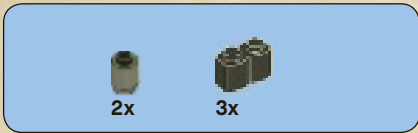

5

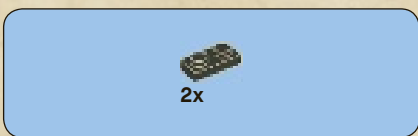
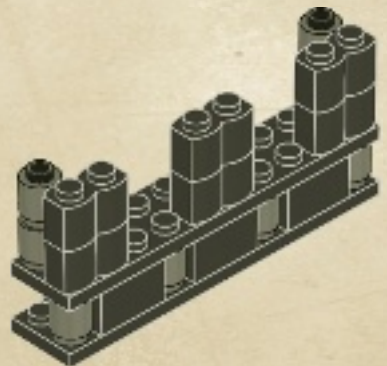

6

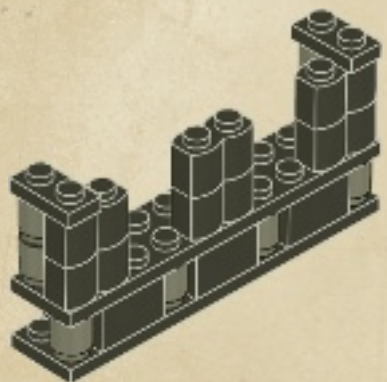

7

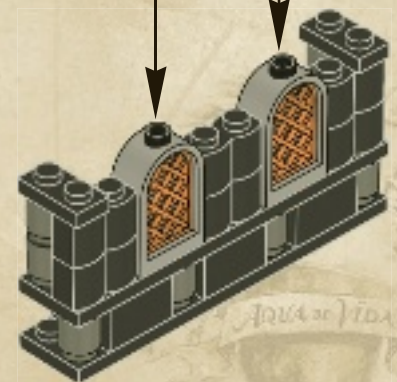
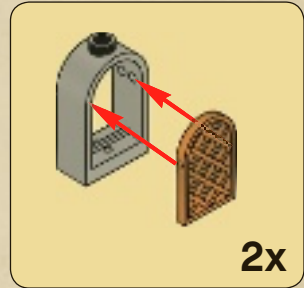

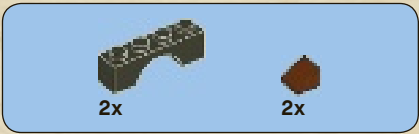

8

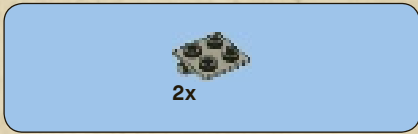

9

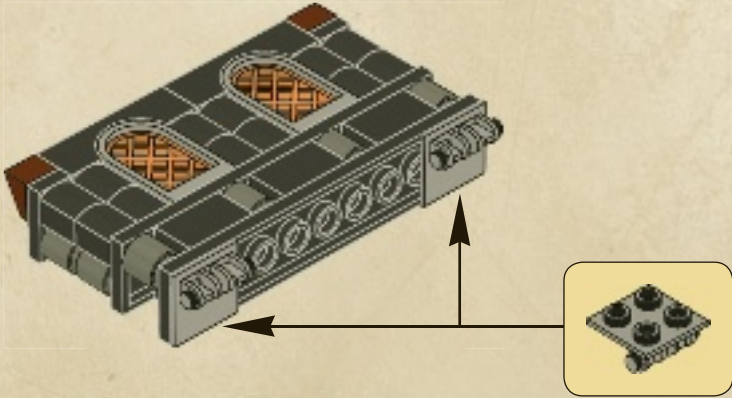



58

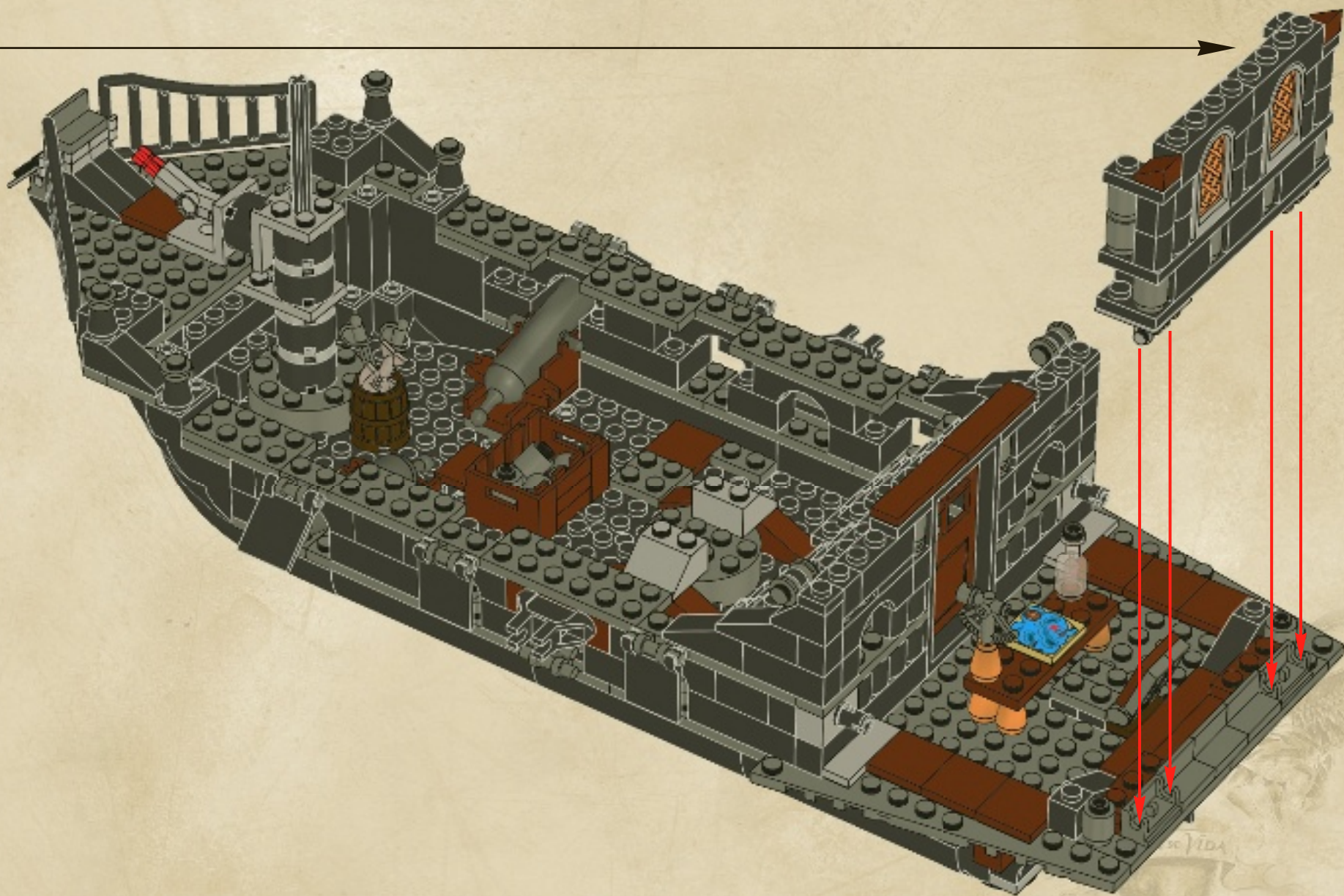

59

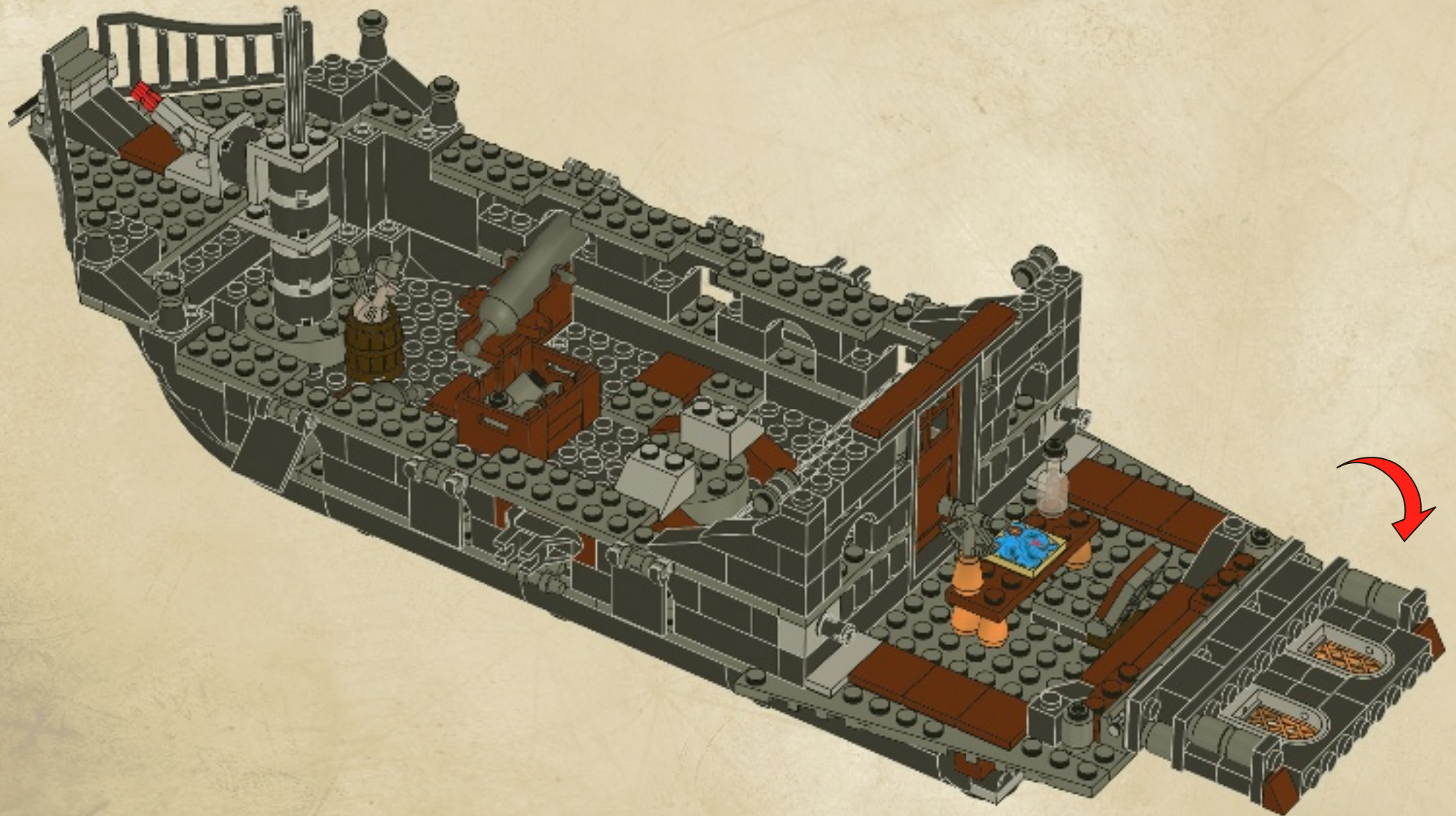

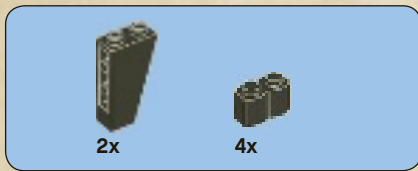

60

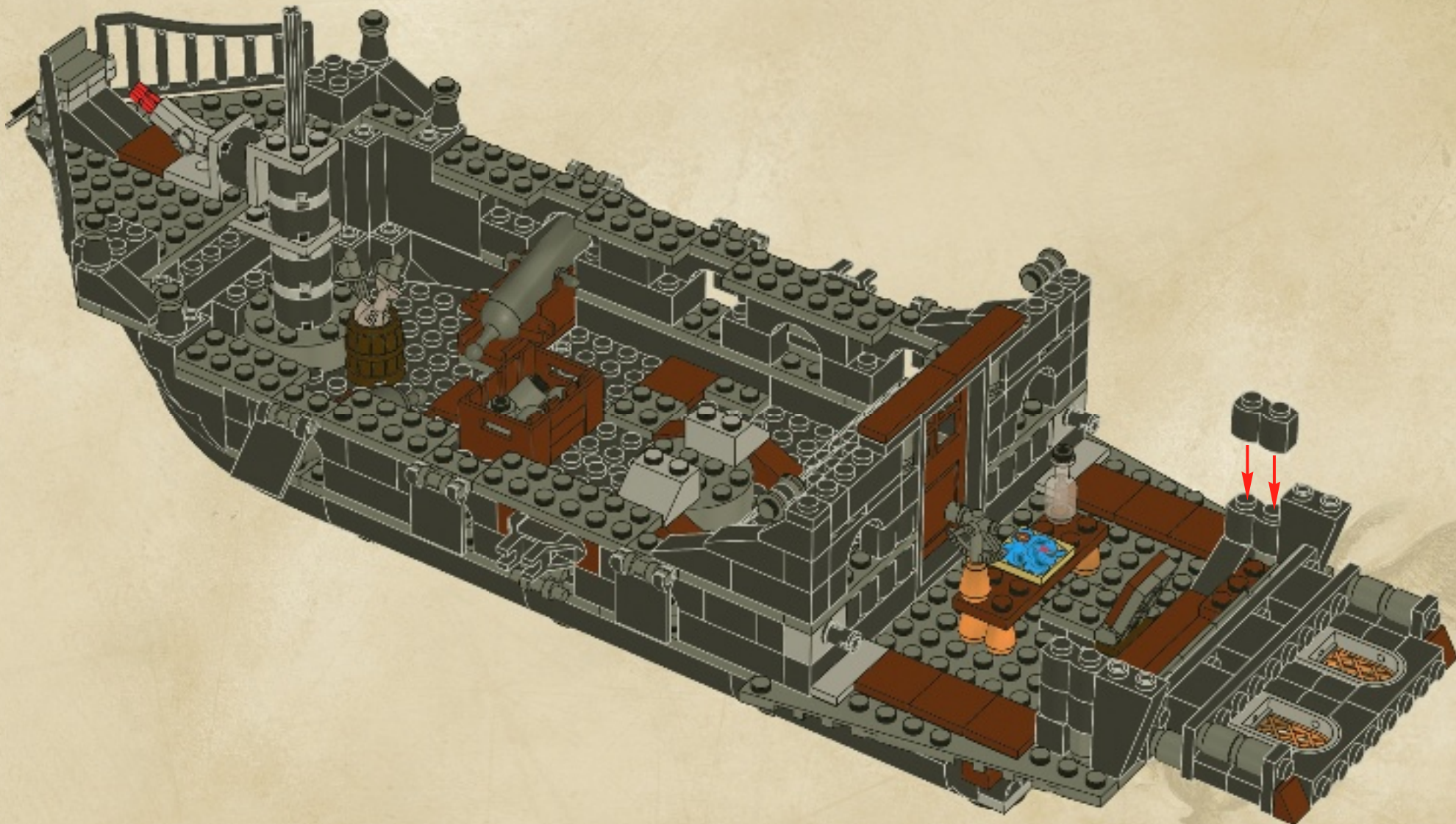



# 61

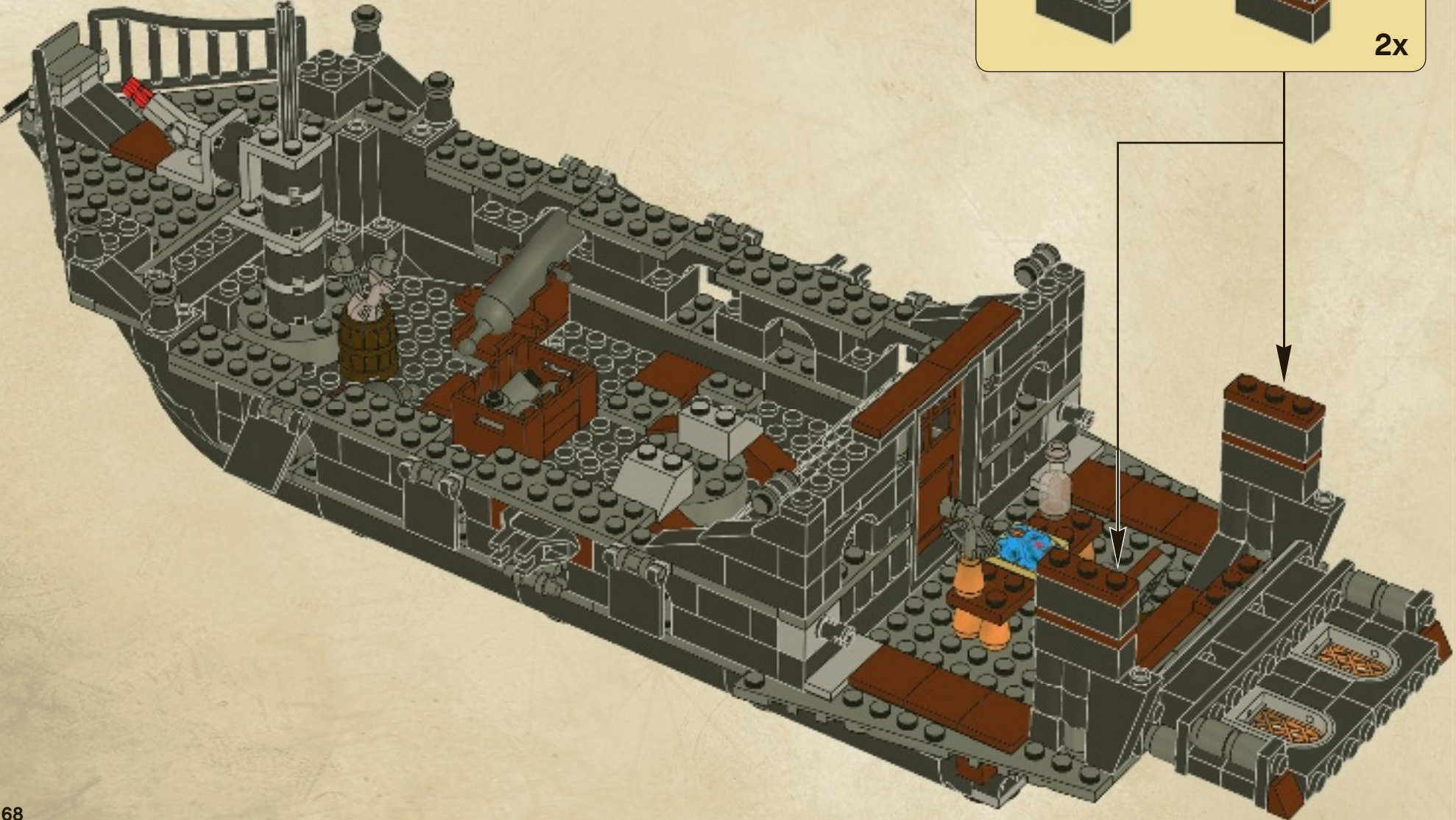
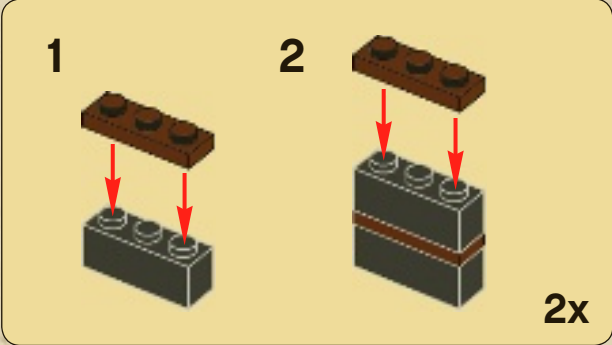

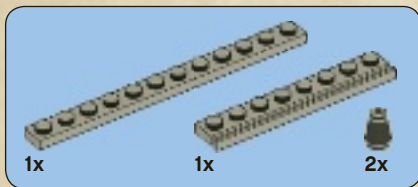

62

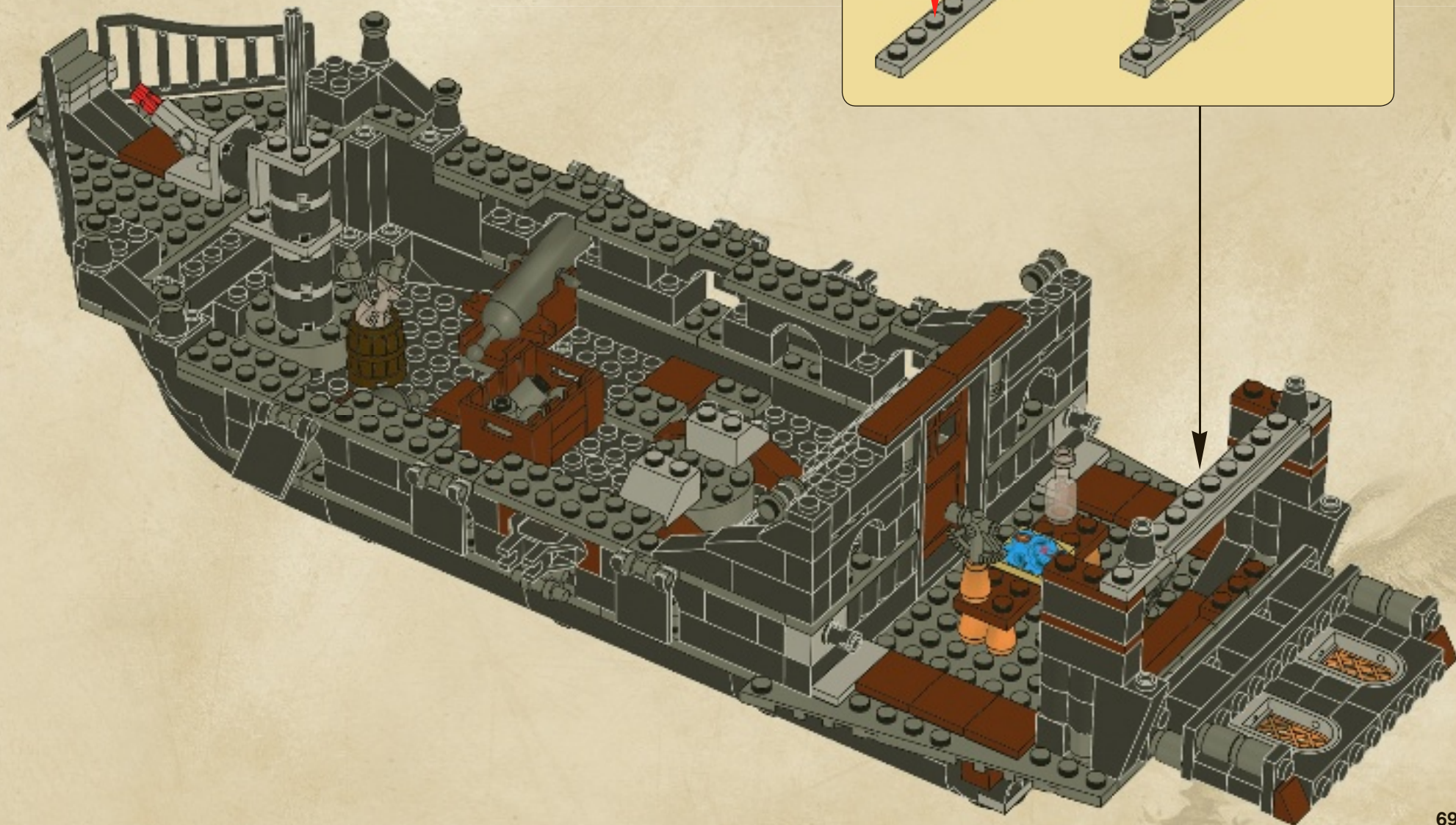
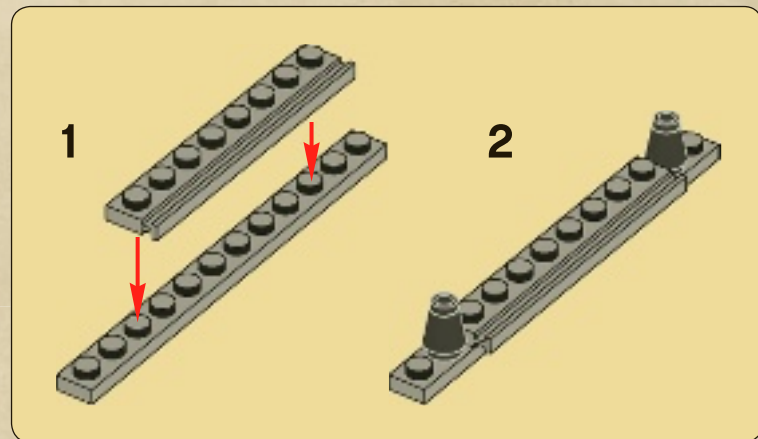

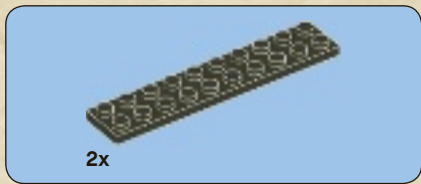

63

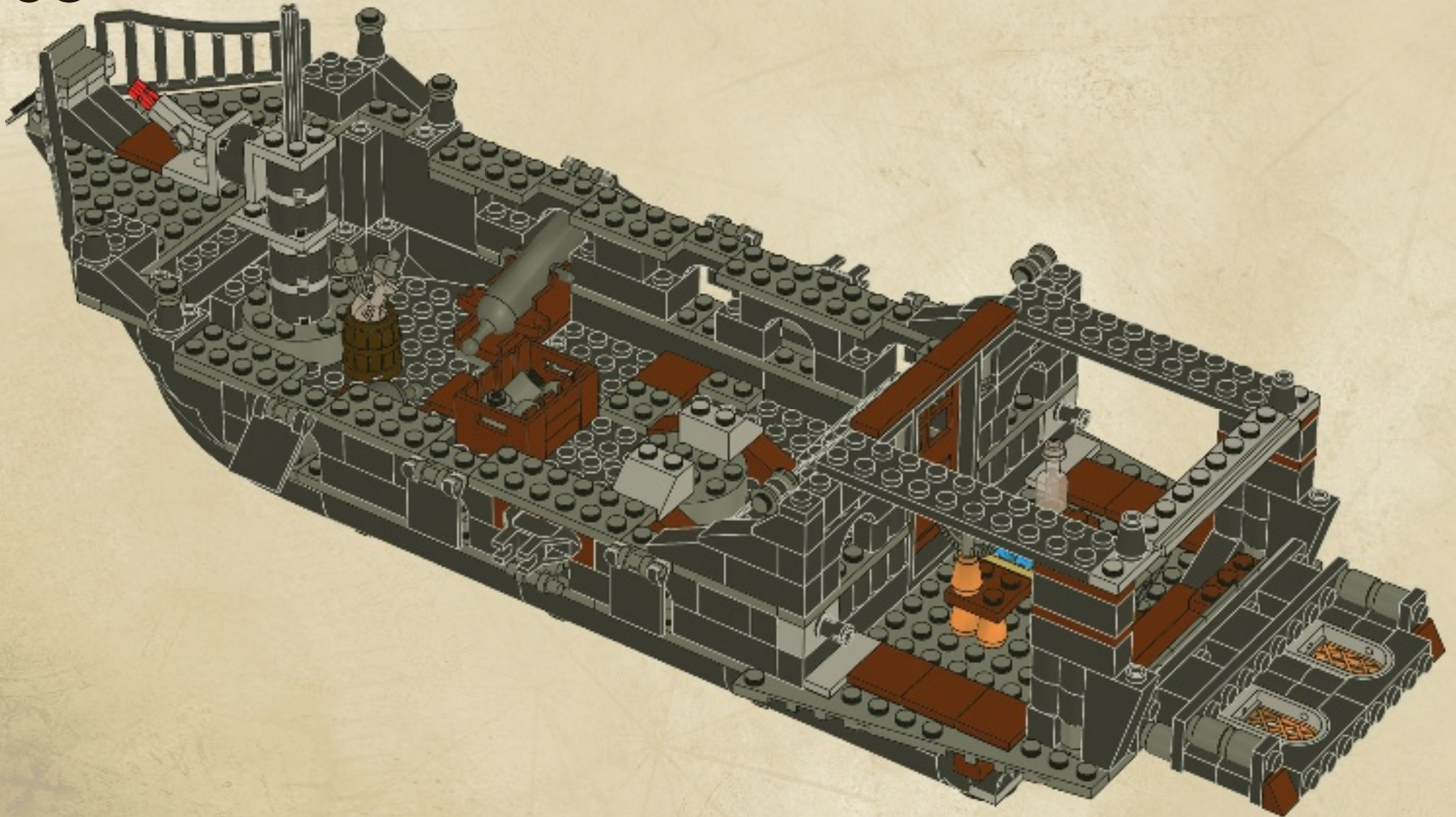

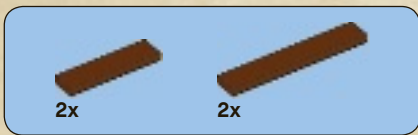

64

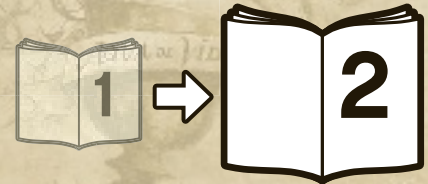
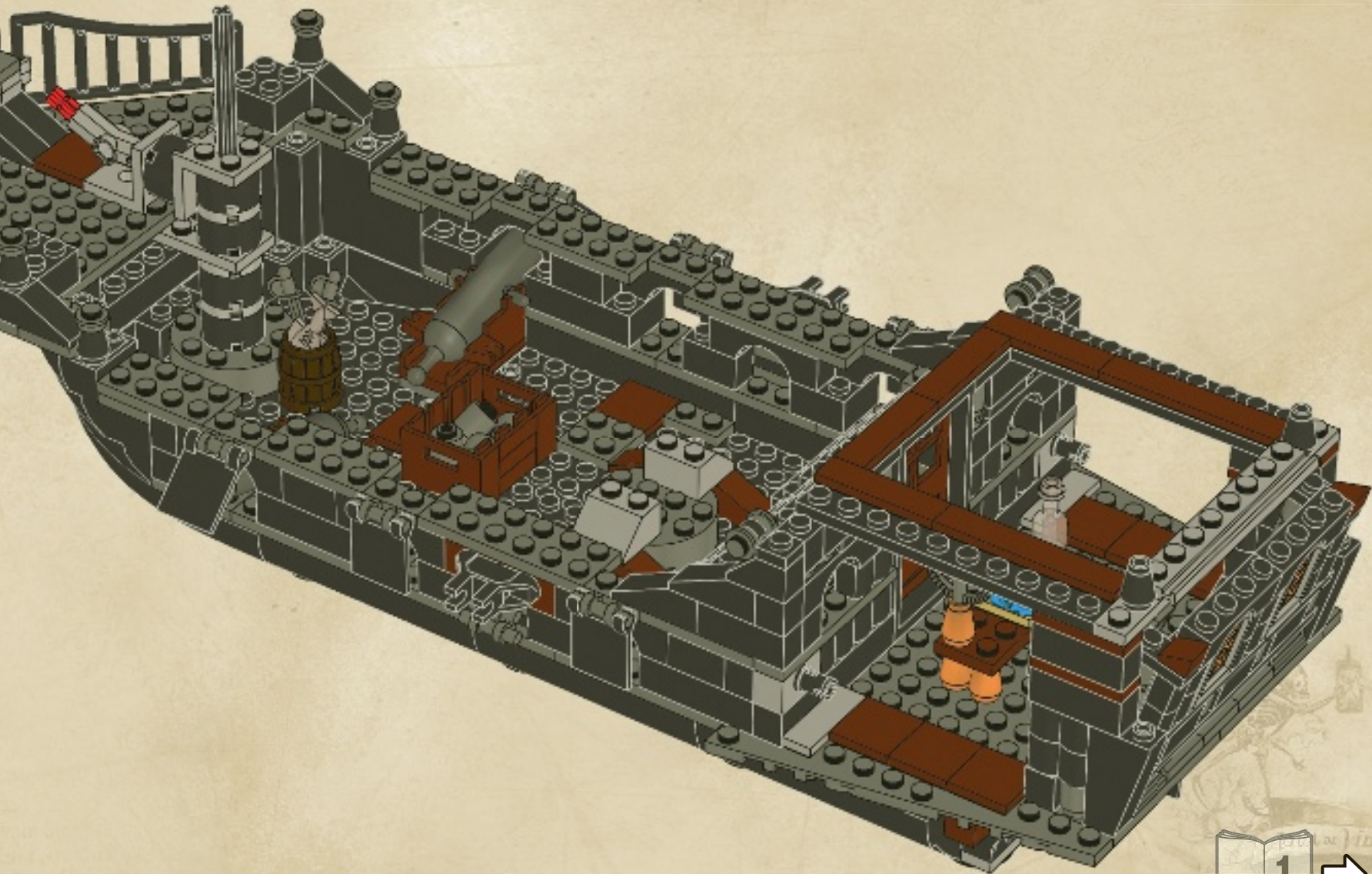



# WIN!

Go to [www.LEGOsurvey.com/product](http://www.LEGOsurvey.com/product) to fill out a survey for a chance to win a cool LEGO® Product. No purchase necessary. Open to all residents where not prohibited.



[www.LEGO.com](http://www.LEGO.com)



## [www.LEGOsurvey.com/product](http://www.LEGOsurvey.com/product)

### GEWINNE!

Nimm an der Umfrage auf [www.LEGOsurvey.com/product](http://www.LEGOsurvey.com/product) teil und hab die Chance ein cooles LEGO® Produkt zu gewinnen! Die Teilnahme am Gewinnspiel führt zu keinerlei Kaufverpflichtungen. Teilnahme in allen nicht ausgeschlossenen Ländern möglich.

### WIN!

Ga naar [www.LEGOsurvey.com/product](http://www.LEGOsurvey.com/product), vul een enquêteformulier in en maak kans op een cool LEGO® product. Geen aankoopverplichting. Iedereen mag deelnemen, uitgezonderd ingezetenden van landen waar een enquêteverbod geldt.

### GAGNE!

Visite [www.LEGOsurvey.com/product](http://www.LEGOsurvey.com/product) pour répondre à un questionnaire et avoir une chance de gagner un produit LEGO® très cool ! Aucune obligation d'achat. Ouvert à tous les résidents des pays autorisés.

### 当てよう!

[www.LEGOsurvey.com/product](http://www.LEGOsurvey.com/product) にアクセスして、アンケートにご記入ください。当選者にはレゴ製品を差し上げます。お買い上げの必要はありません。禁止されていない限り、すべての皆様にご利用いただけます。