

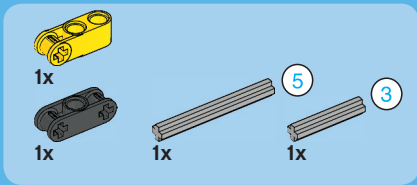

# TECHNIC

42004

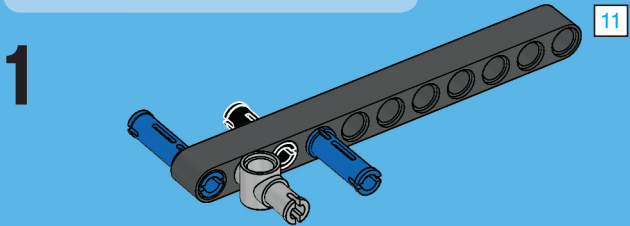

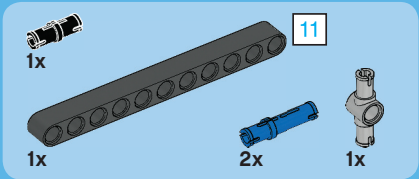
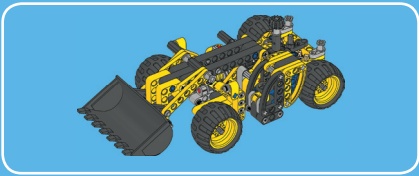

2

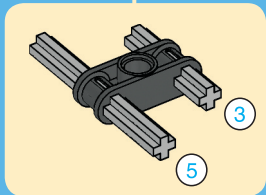
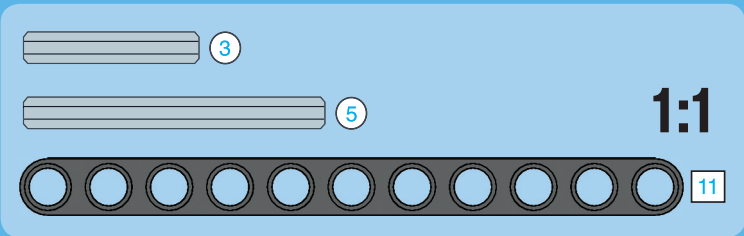
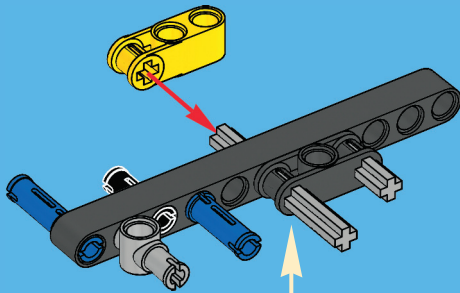





3

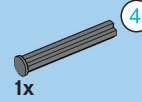
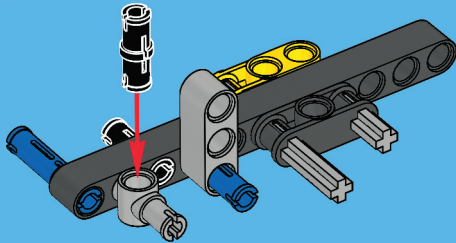

4

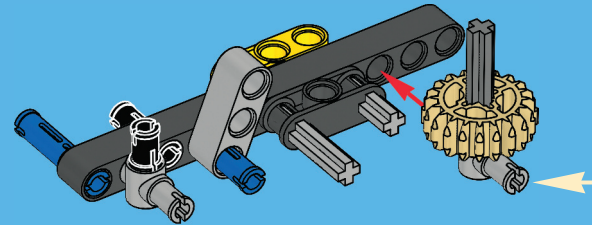
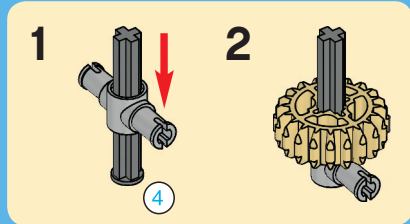

1:1

3





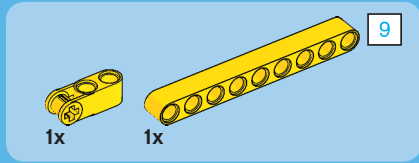

7

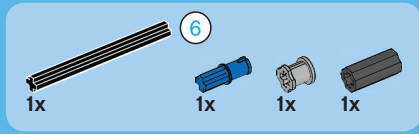
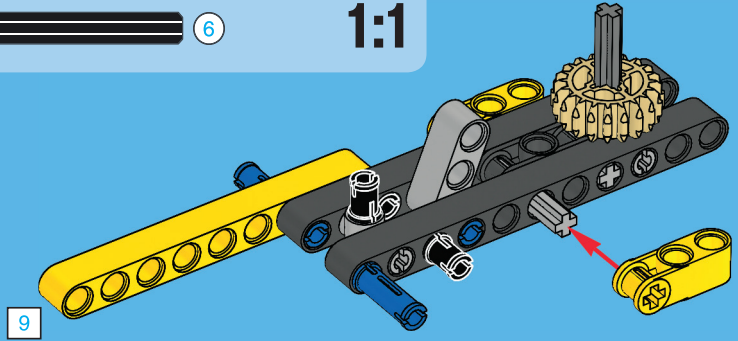
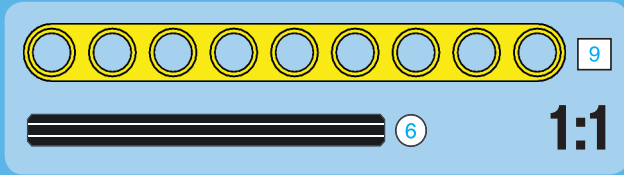

8

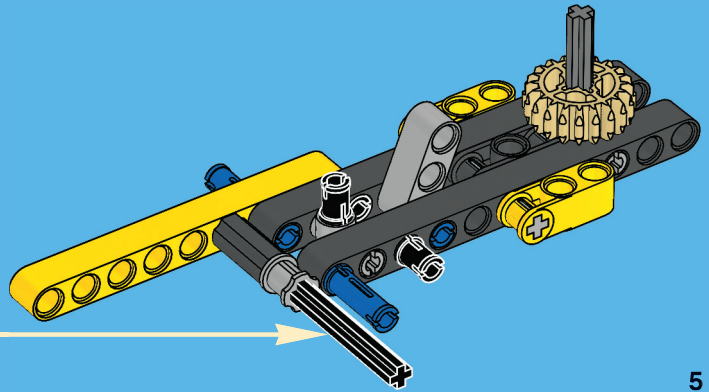
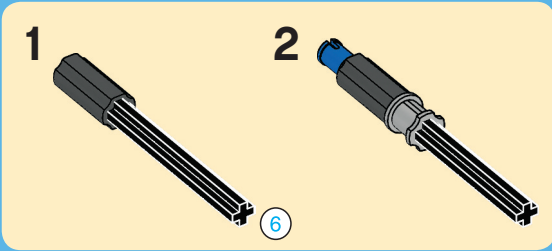

5





1x

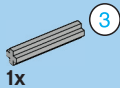

1x

3

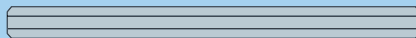

7

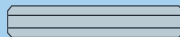

3

1:1

1

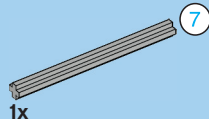
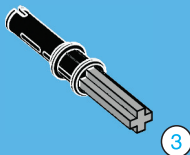

1x



1x

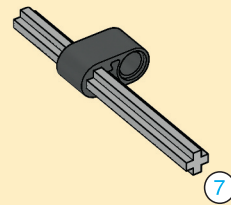

7

3



1x



1x

2

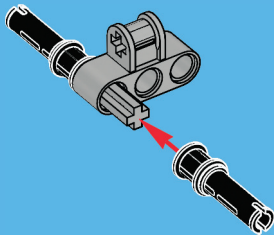

6

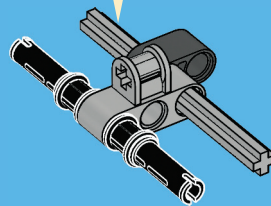



1x

4

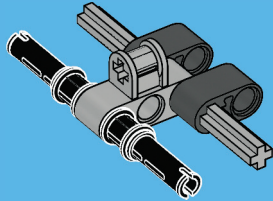

2x



1x

5

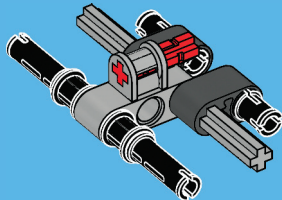

1x

6

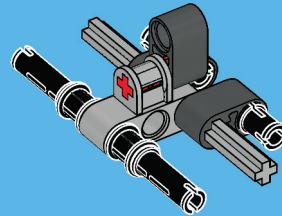

9

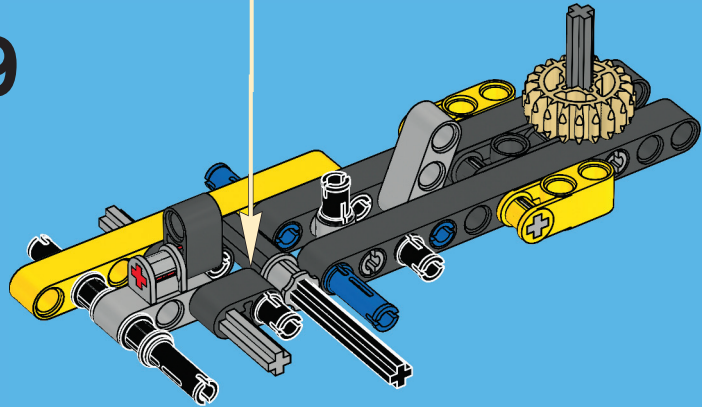

7

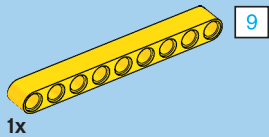

10

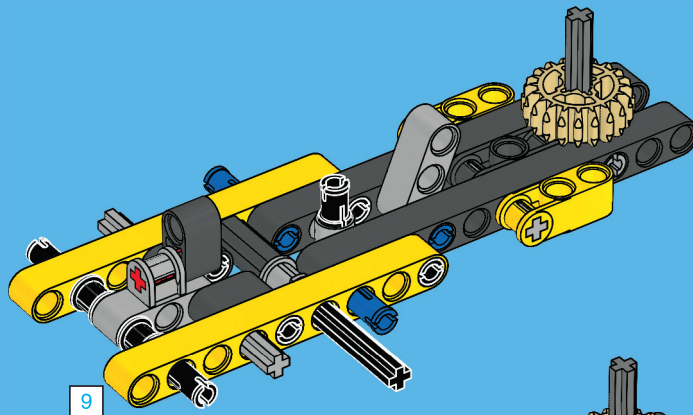

11

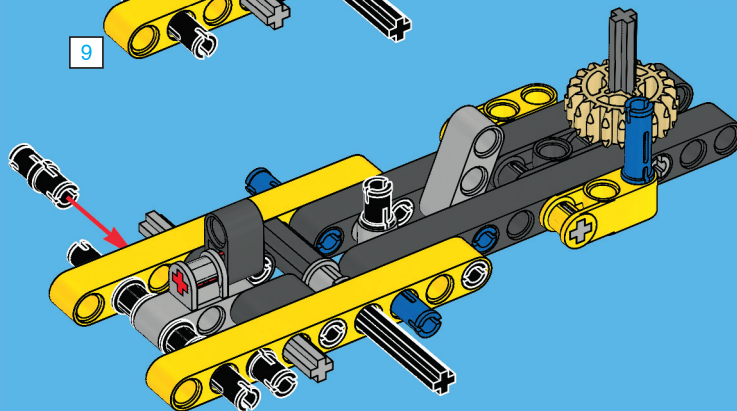

8



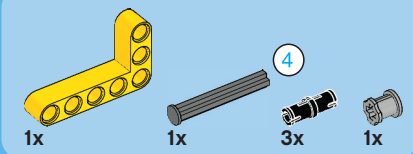

# 12

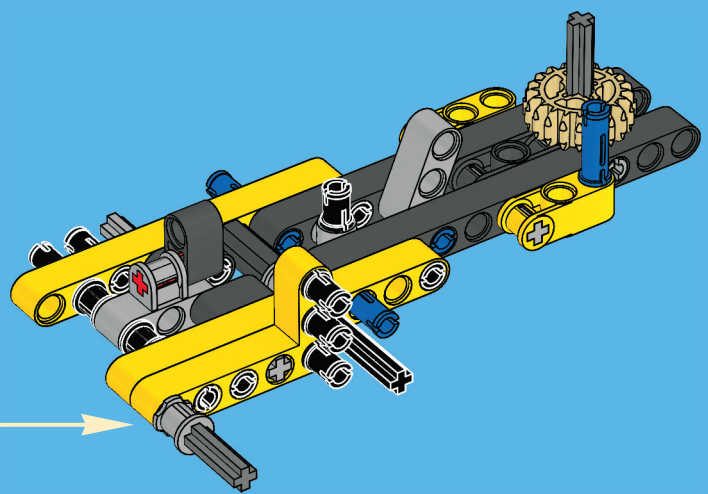
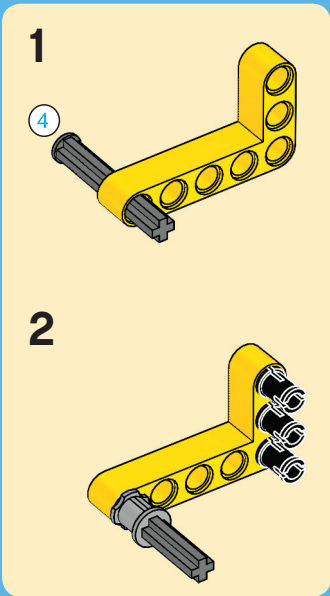

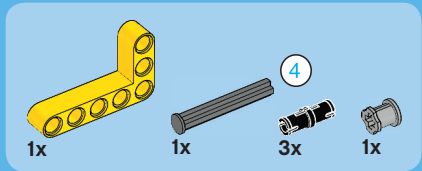

13

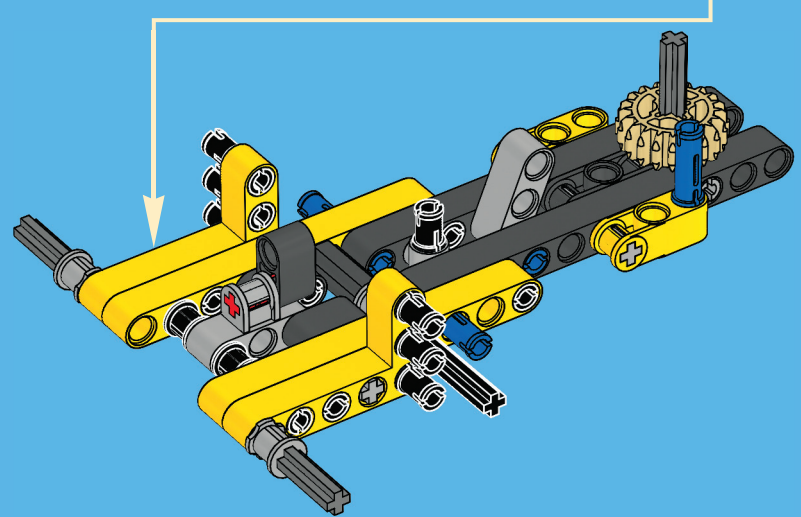
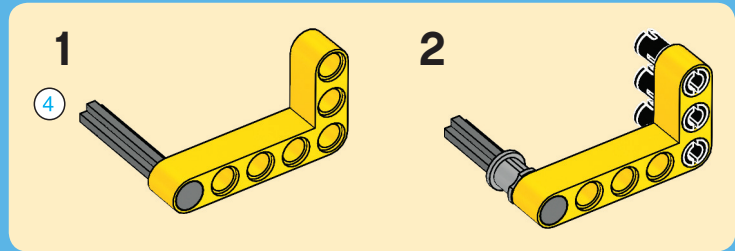

10

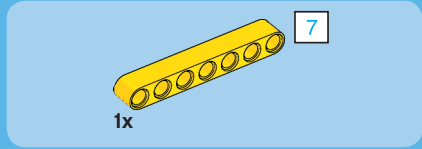
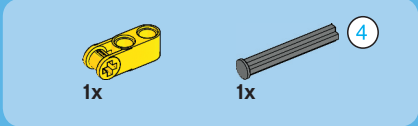
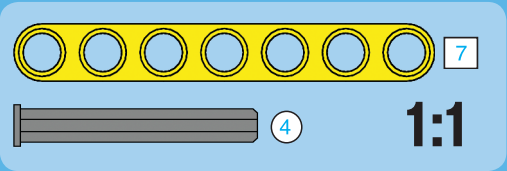
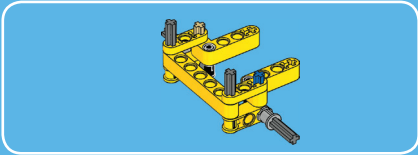

1

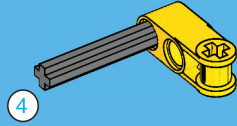

3

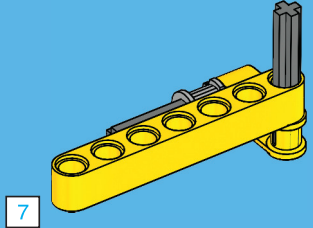
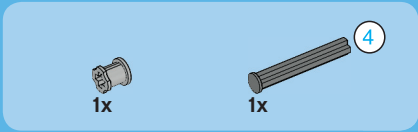

2

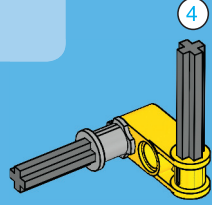



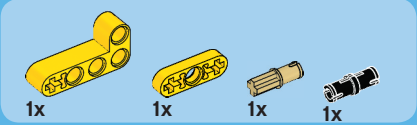

4

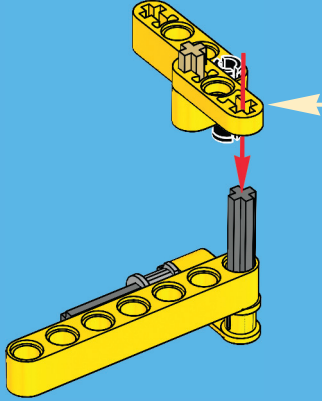
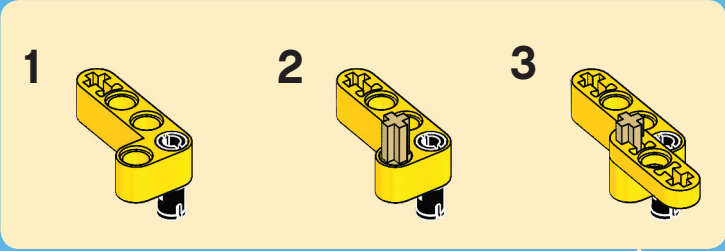

12

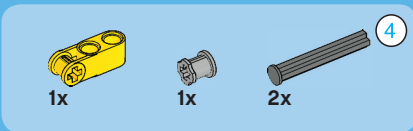

# 5

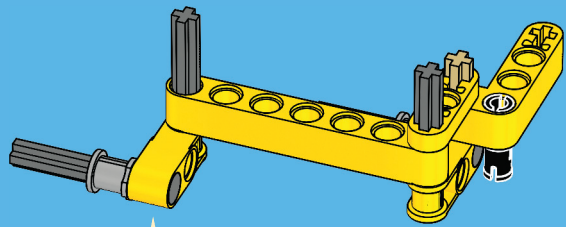
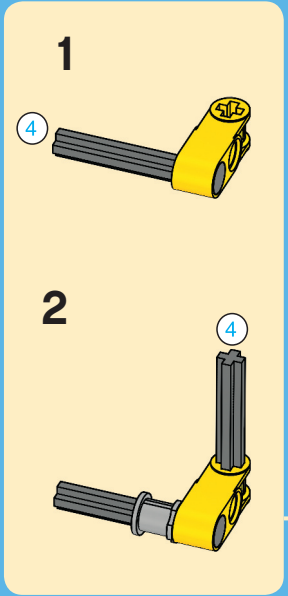

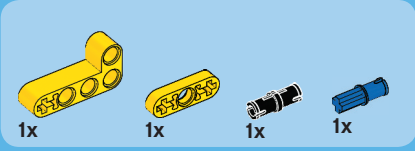

6

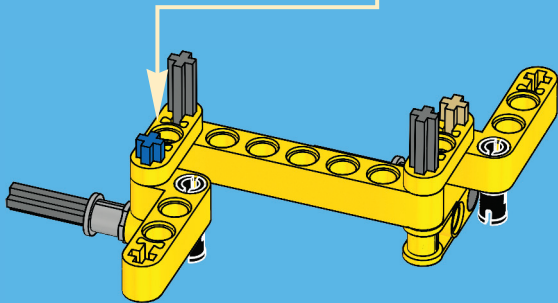
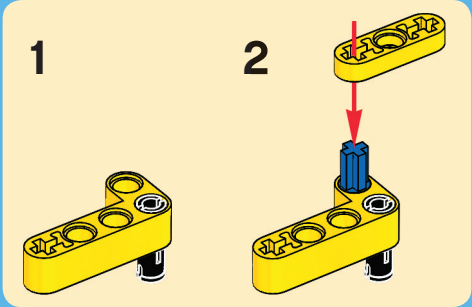

14

14

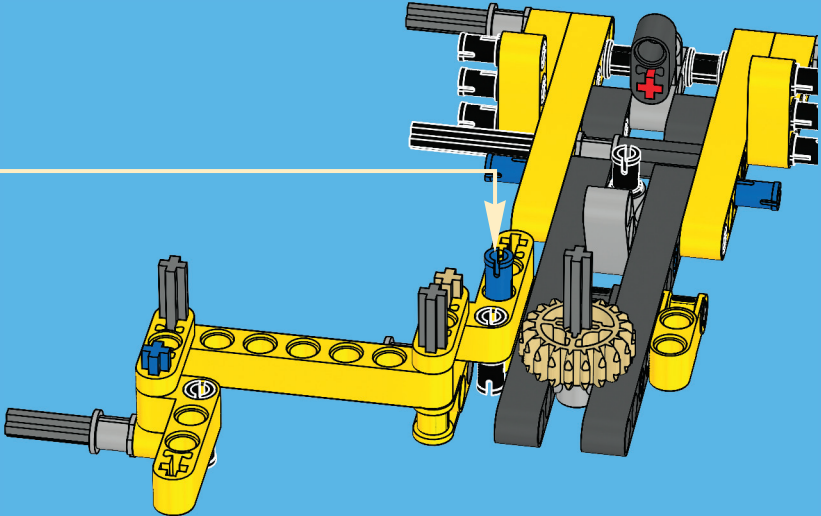



15

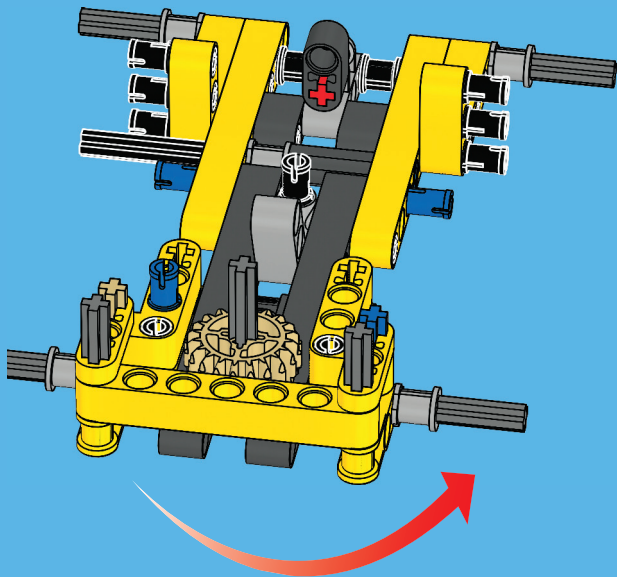

16

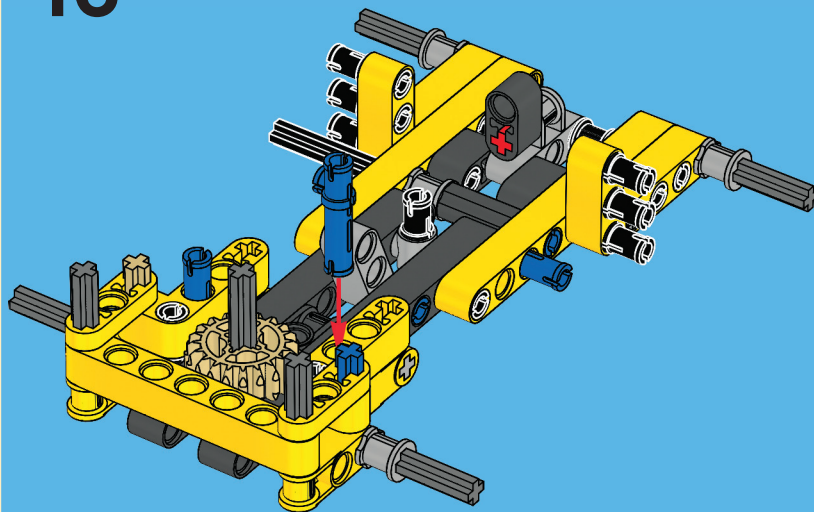

1x

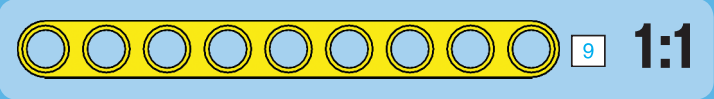
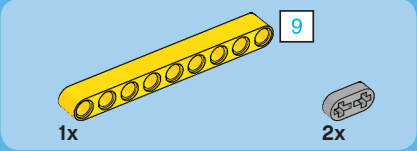

17

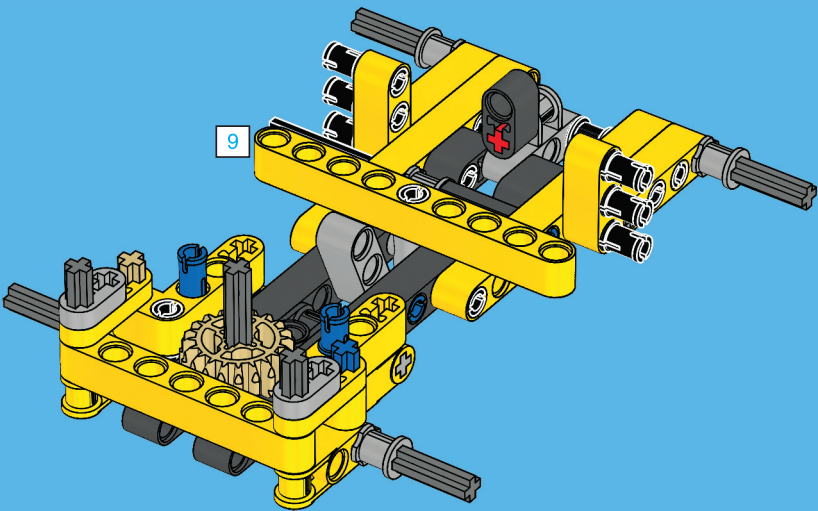

16



1x



2x

# 18

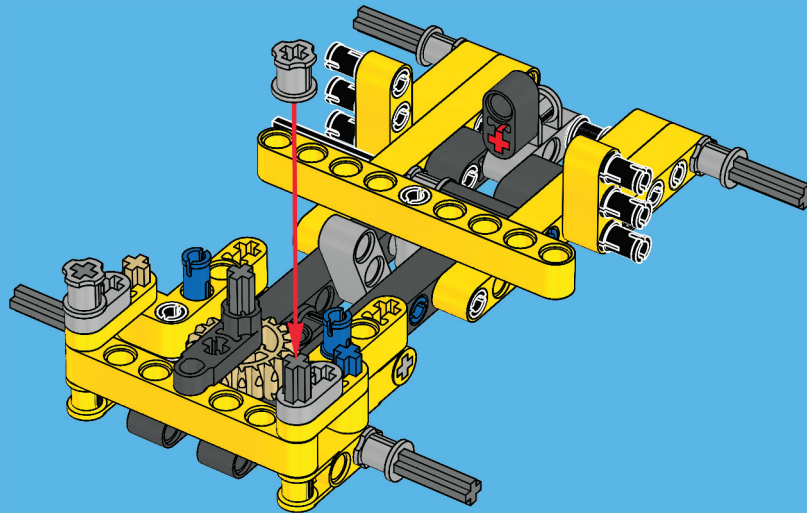

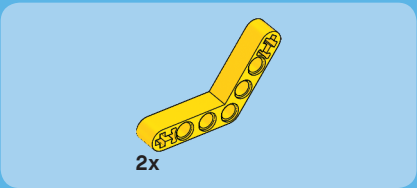

19

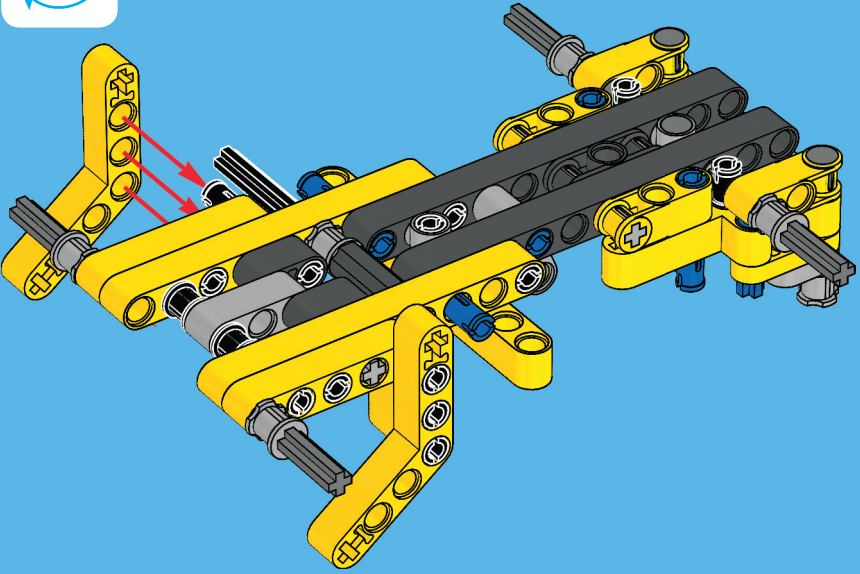

18



2x

# 20

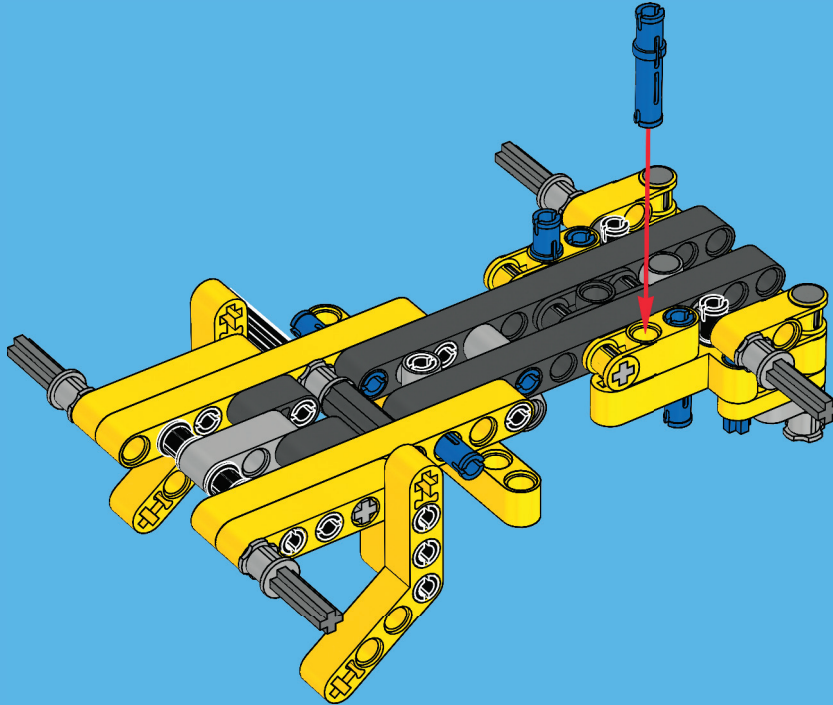

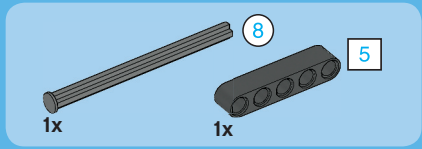

# 21

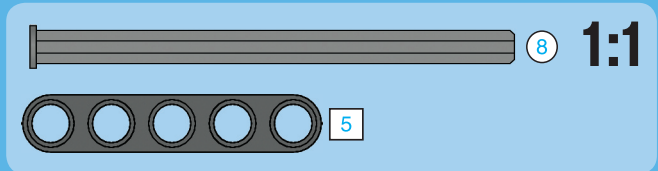
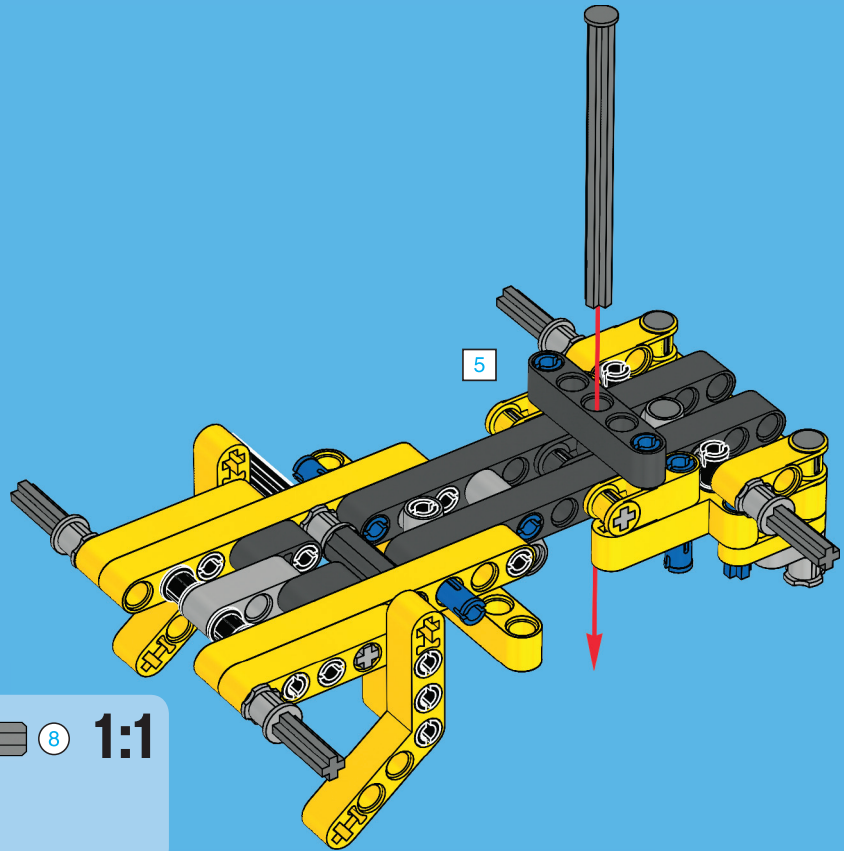

# 20



1x

# 22

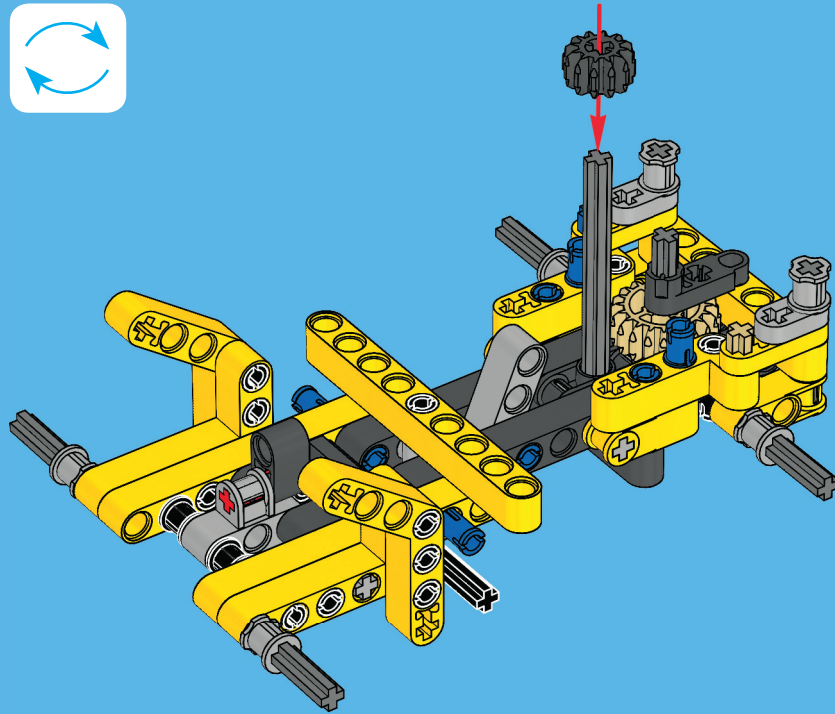



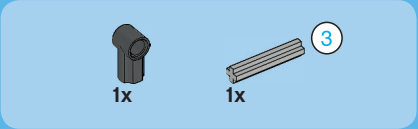

1

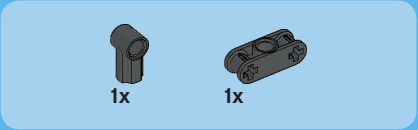
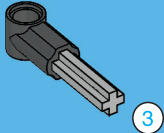

2

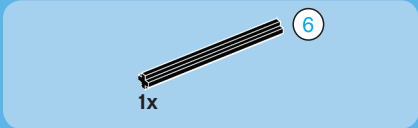
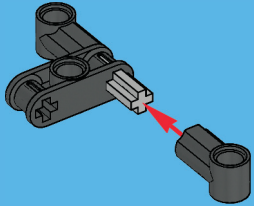

3

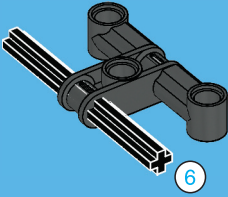



2x

4

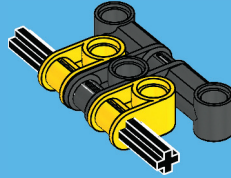

23

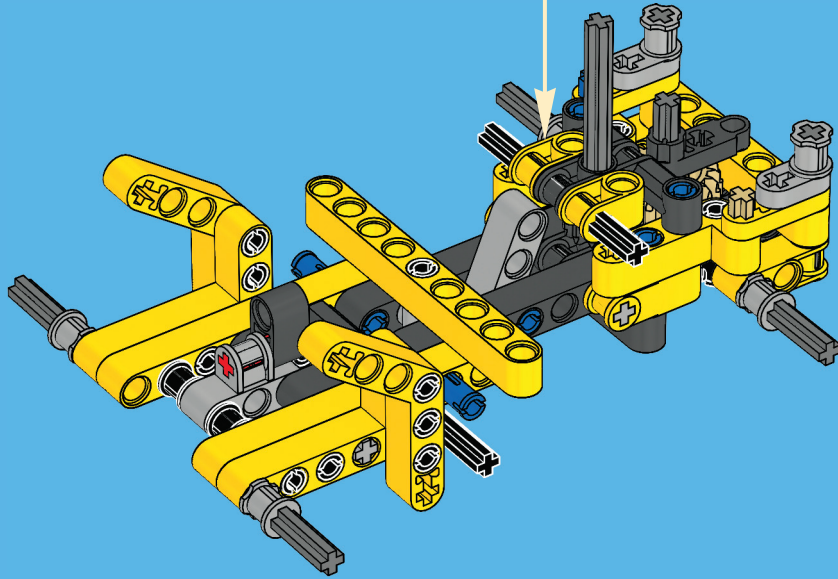

23



1x

# 24

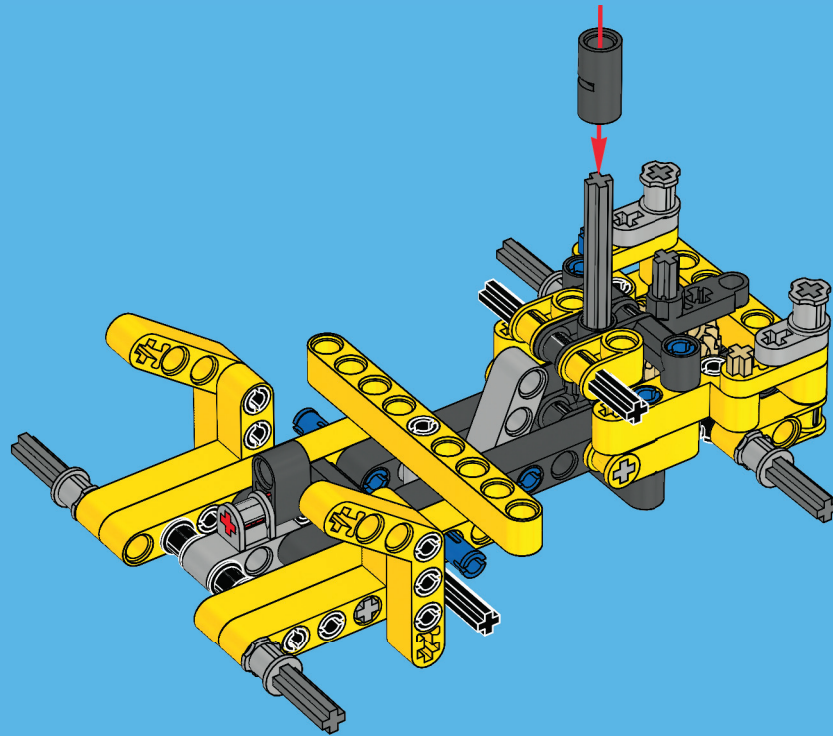

24



1x



1x

# 25

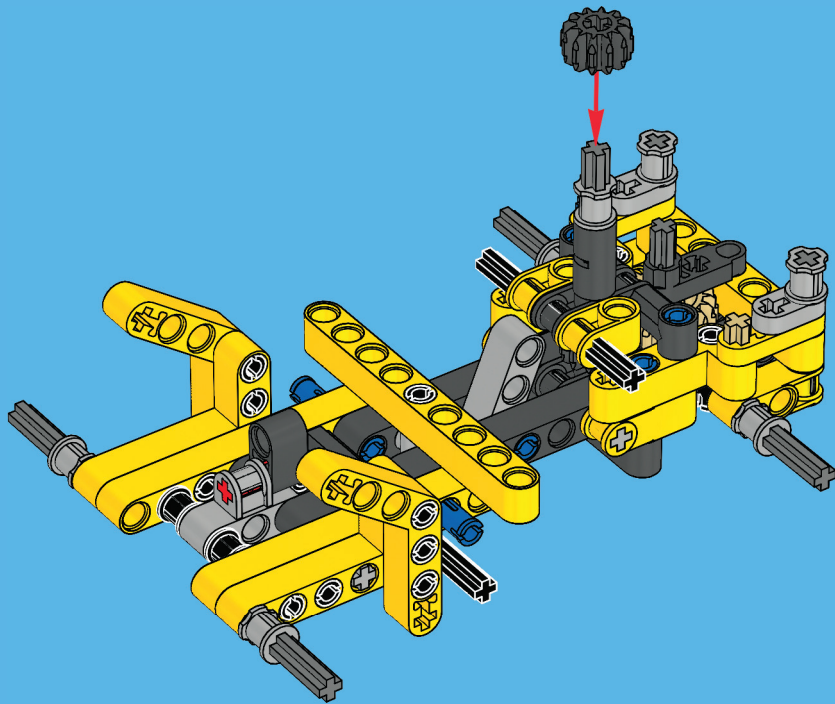

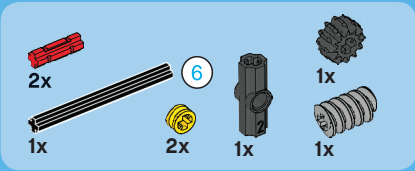

26

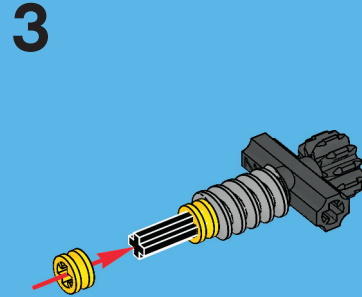
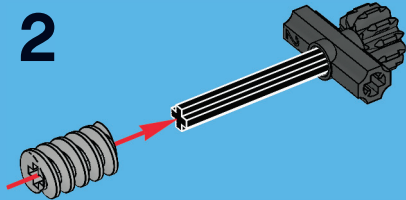
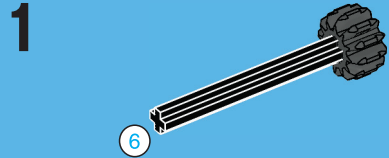

26

4

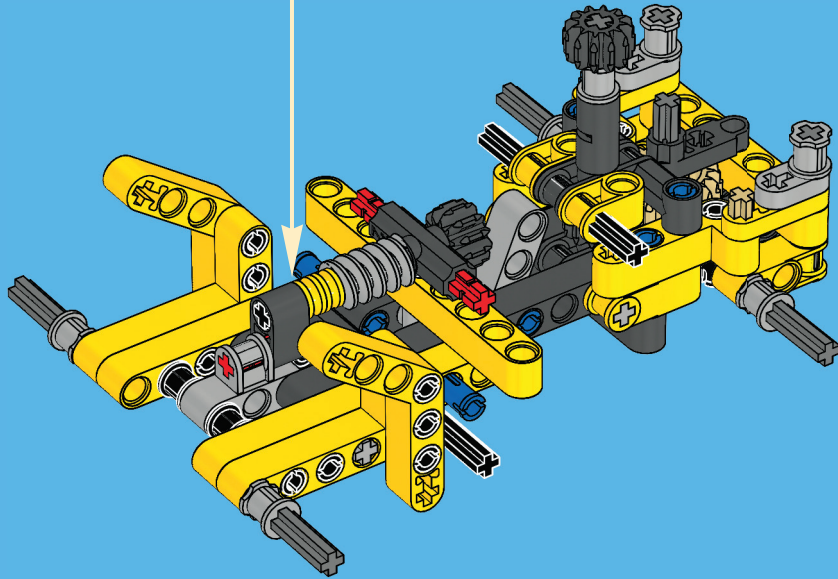
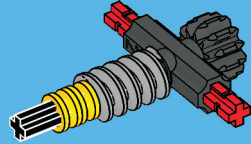

27

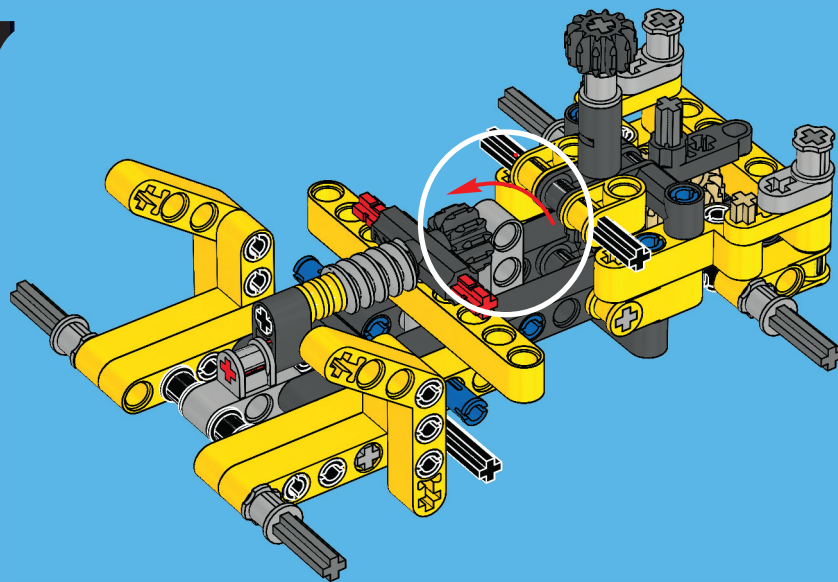

28

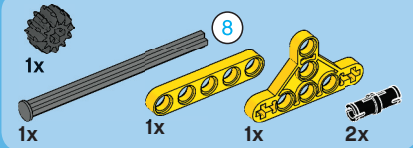

# 28

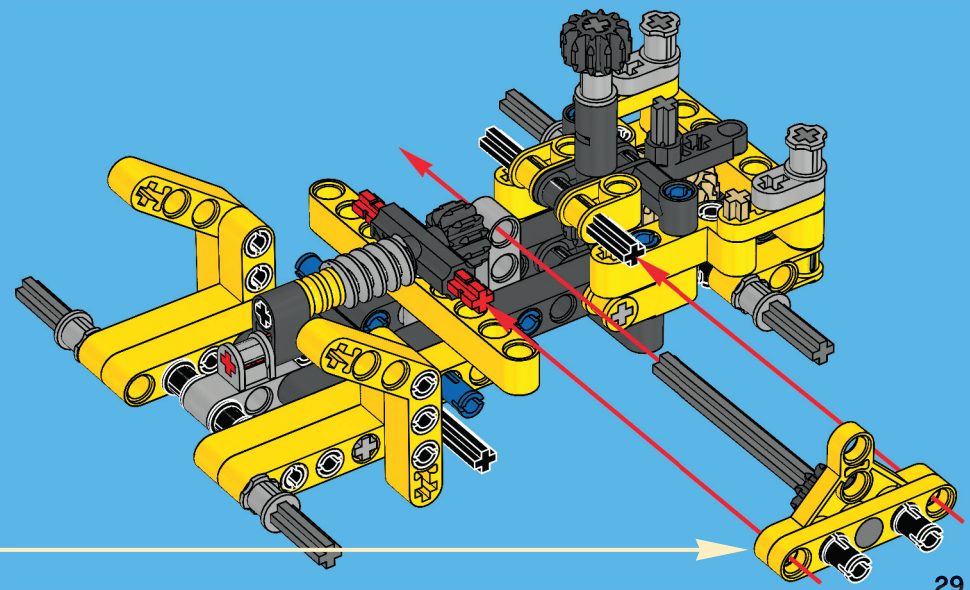
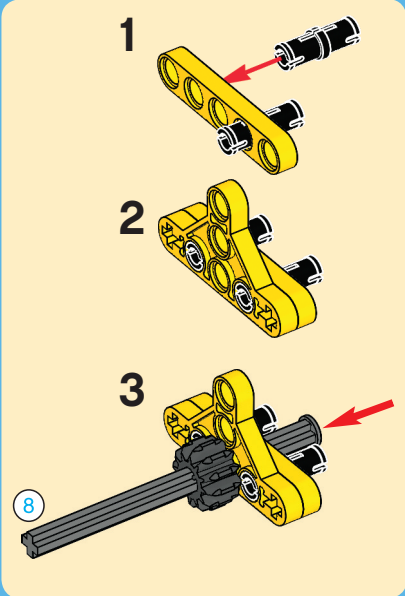



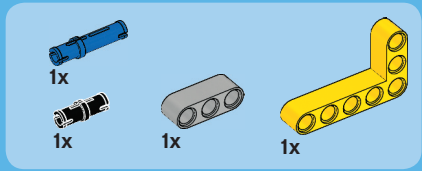

29

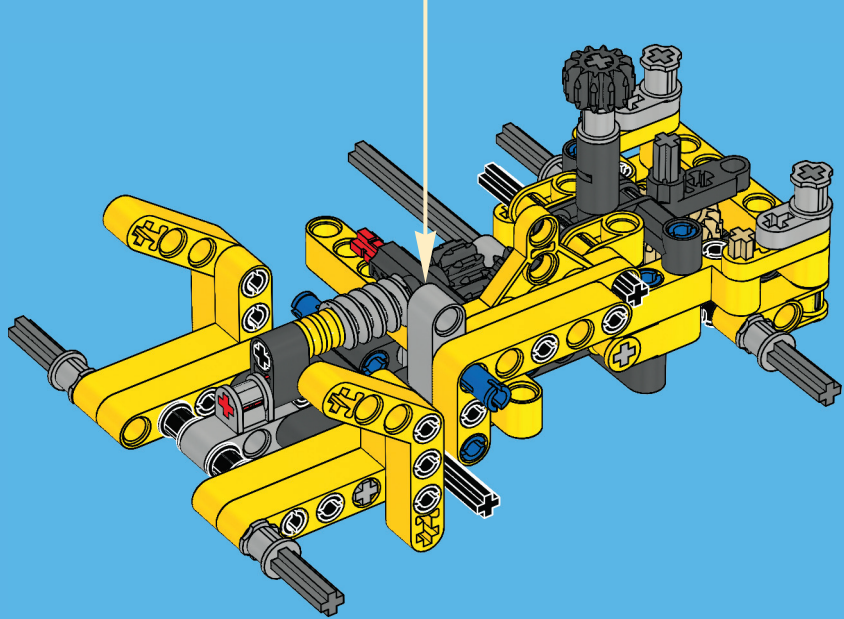
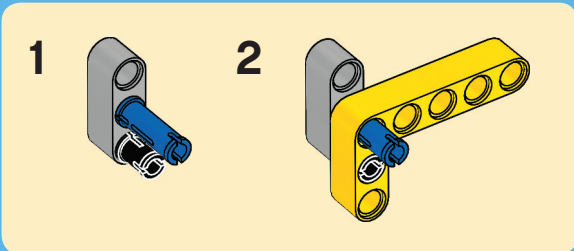

30



30

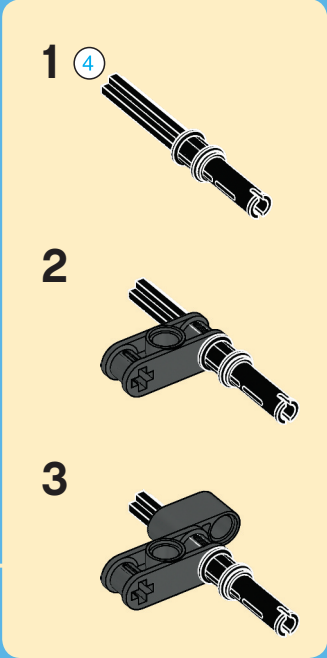
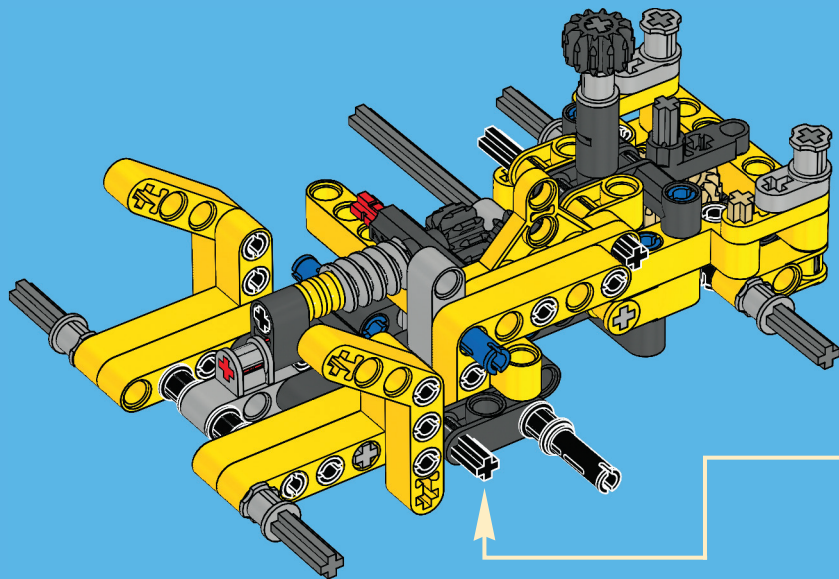

31



1x



1x

# 31

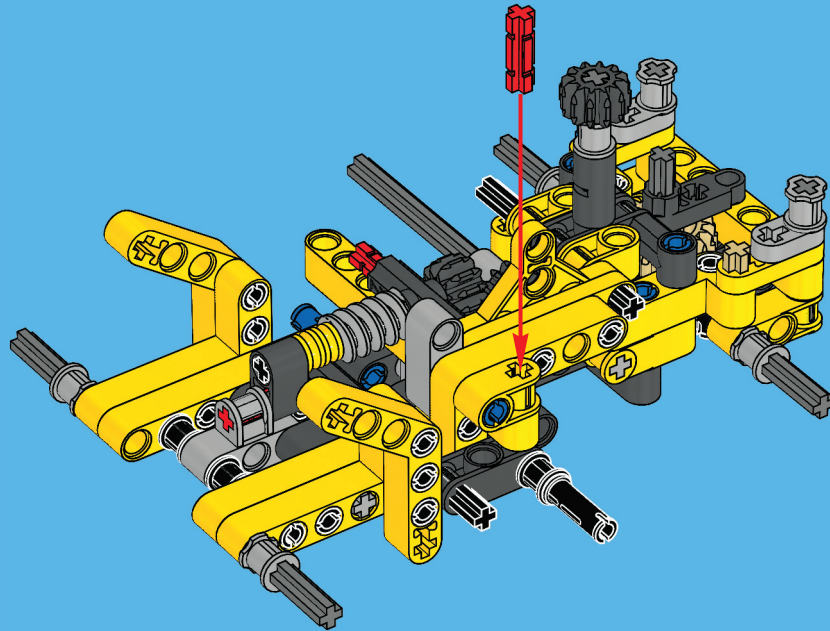

32

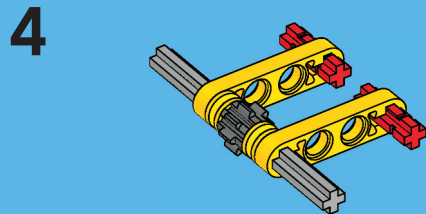
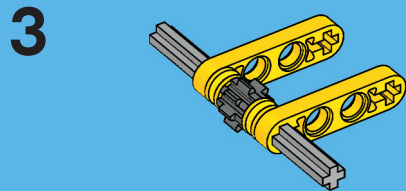
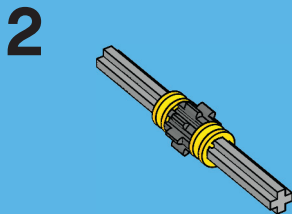
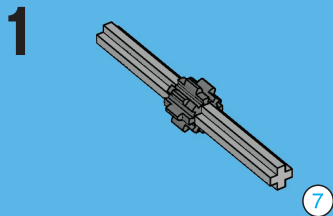
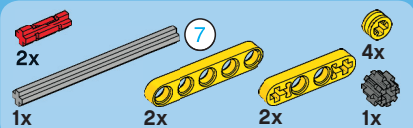

5

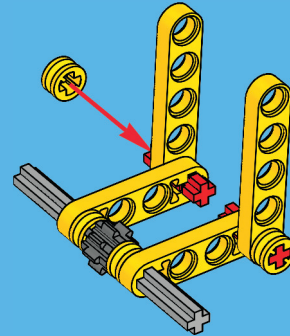

32

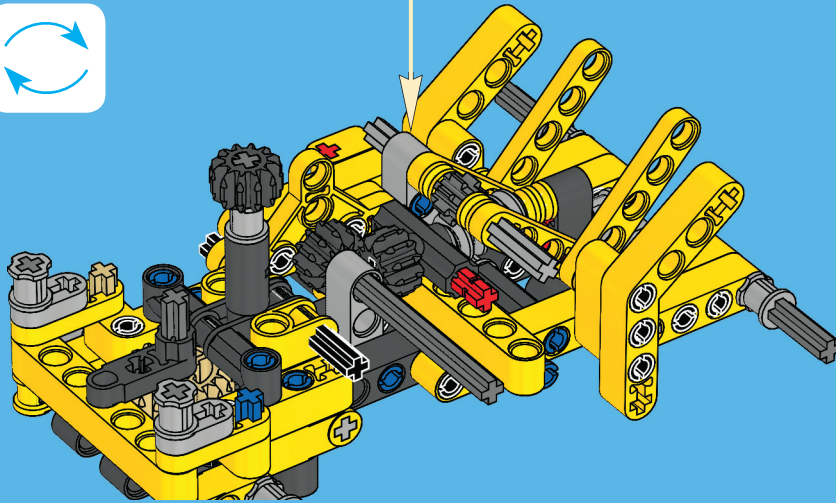

34

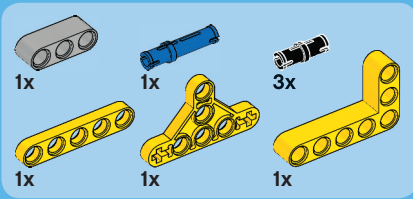

# 33

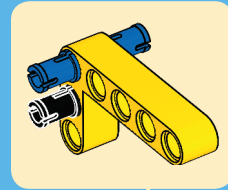
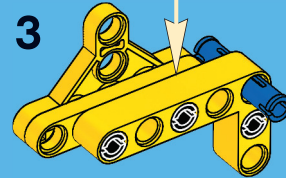
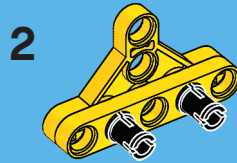
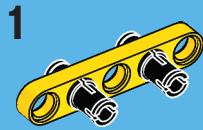

4

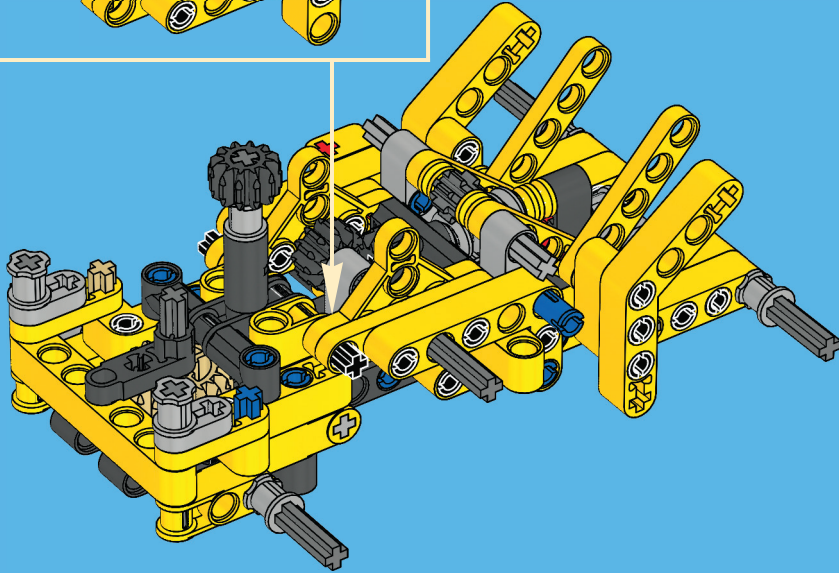
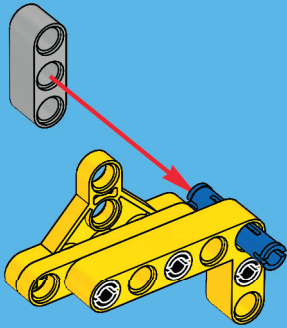



1x



1x

# 34

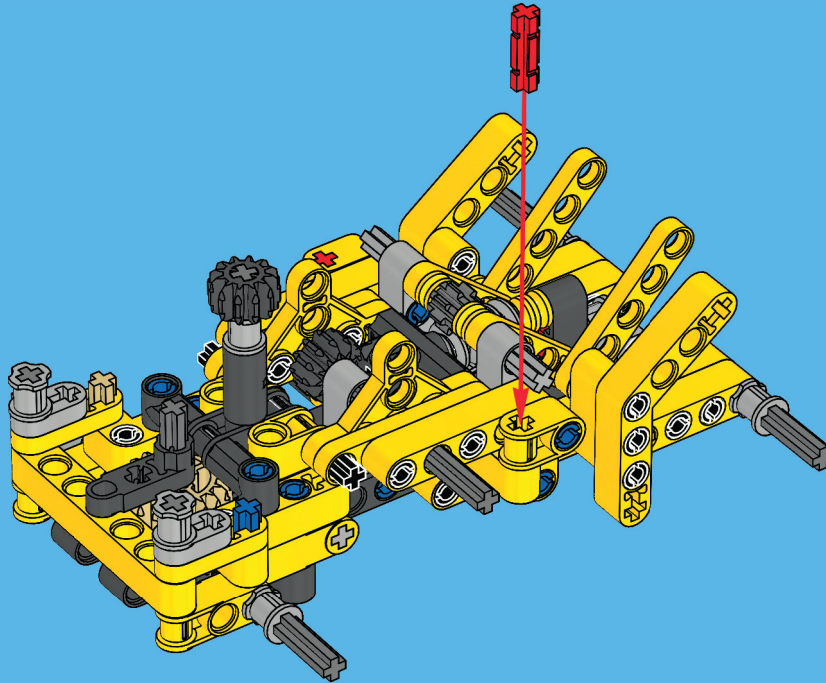





1x



1x

# 35

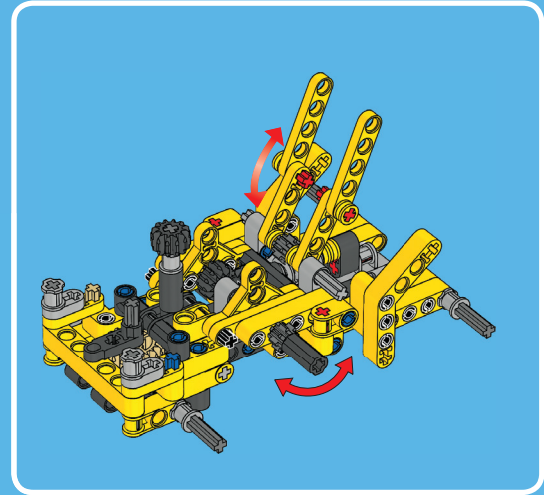
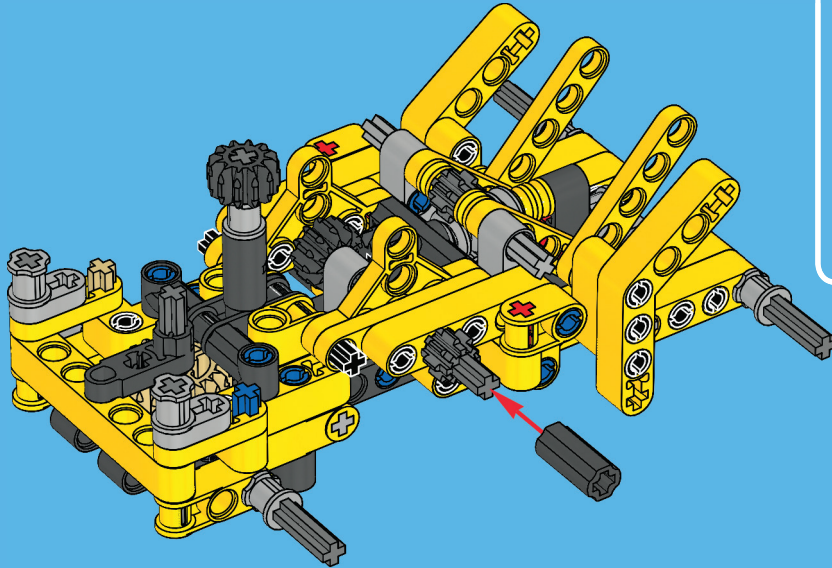

38



1x



1x



1x



1x

# 36

1



2

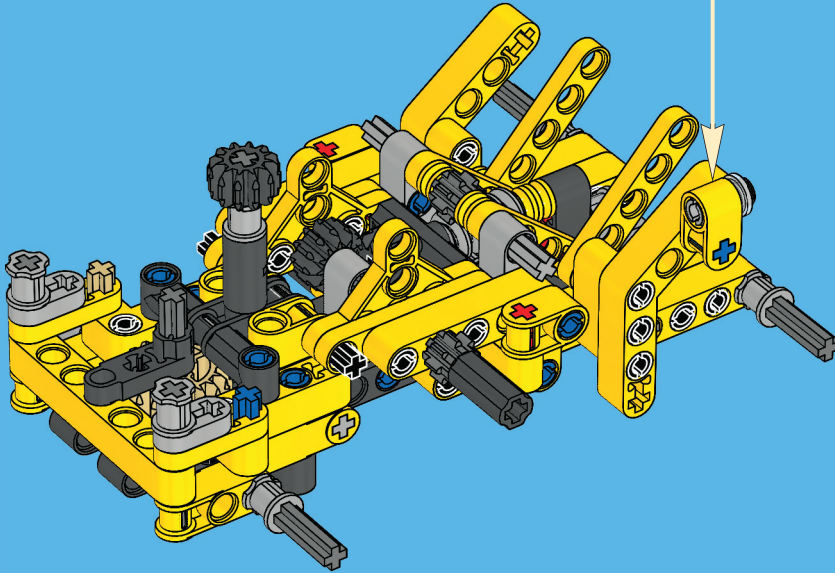
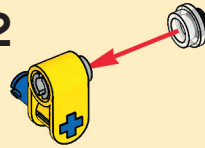

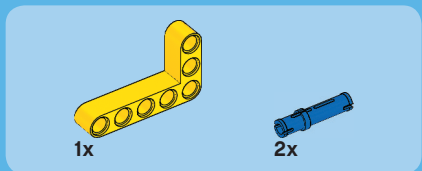
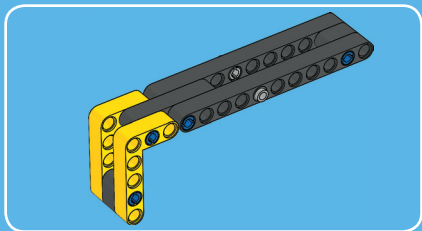

1

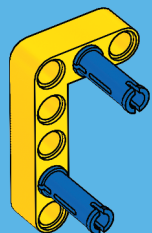

40

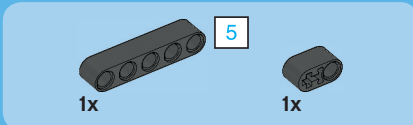
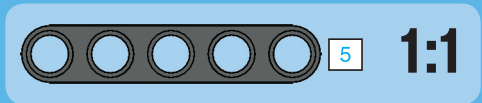

2

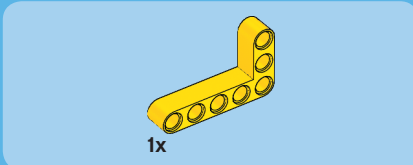
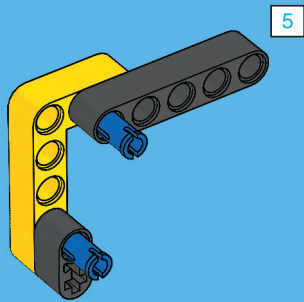

3

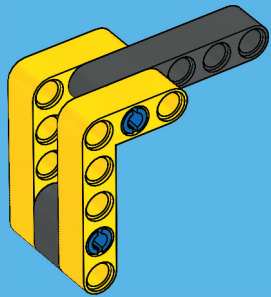



1x



1x

# 4

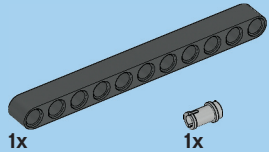
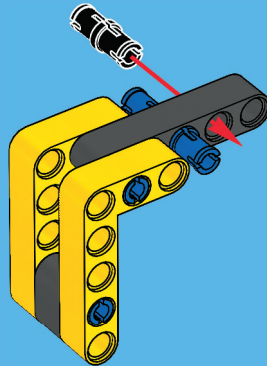

11

1x

1x

1x

# 5

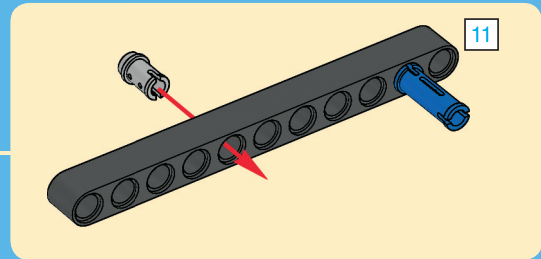
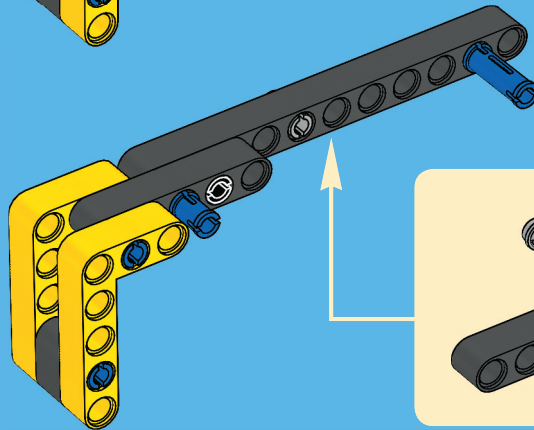

11



11

# 1:1



1x

6

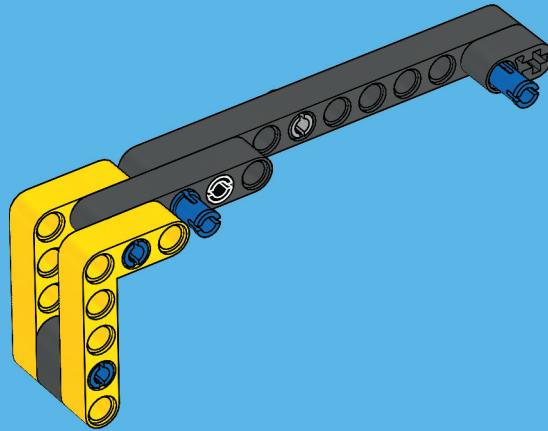

42

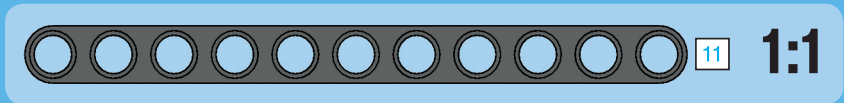
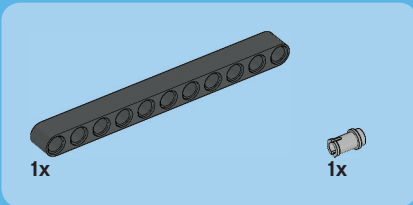

7

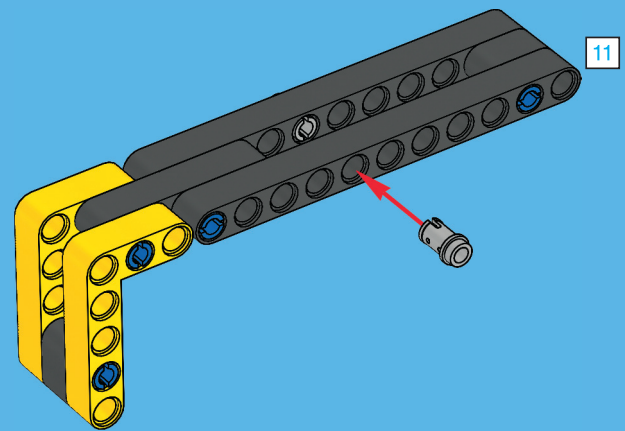

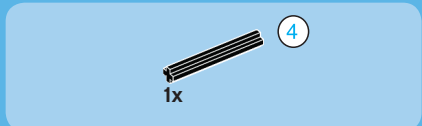

37

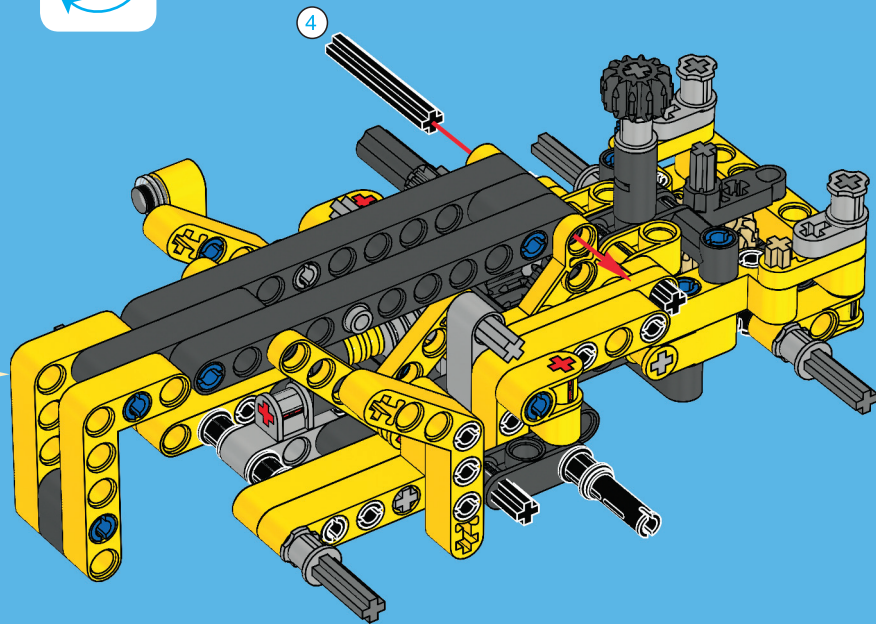

44

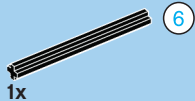

# 38

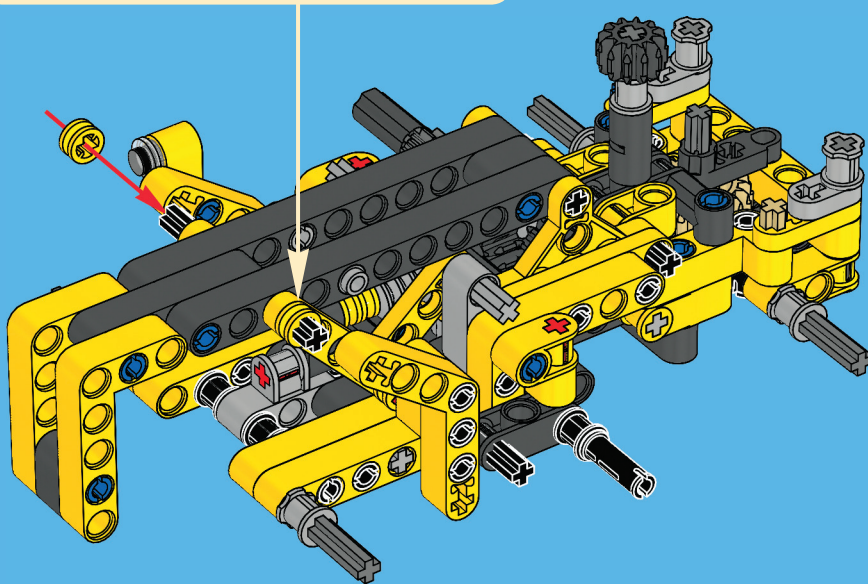



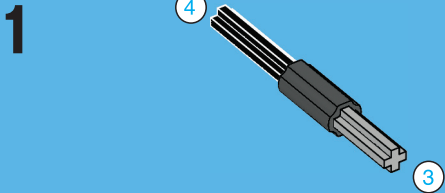
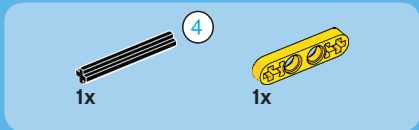
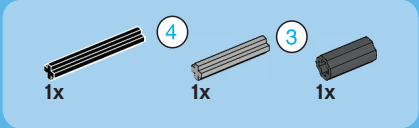
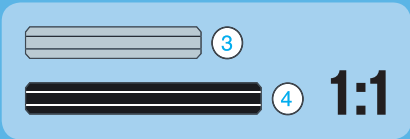

**3**

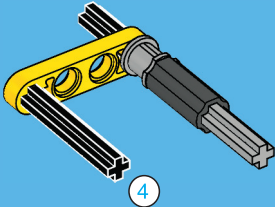
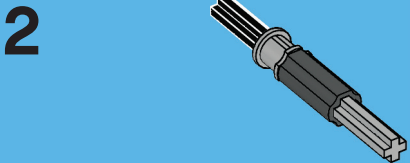

# 39

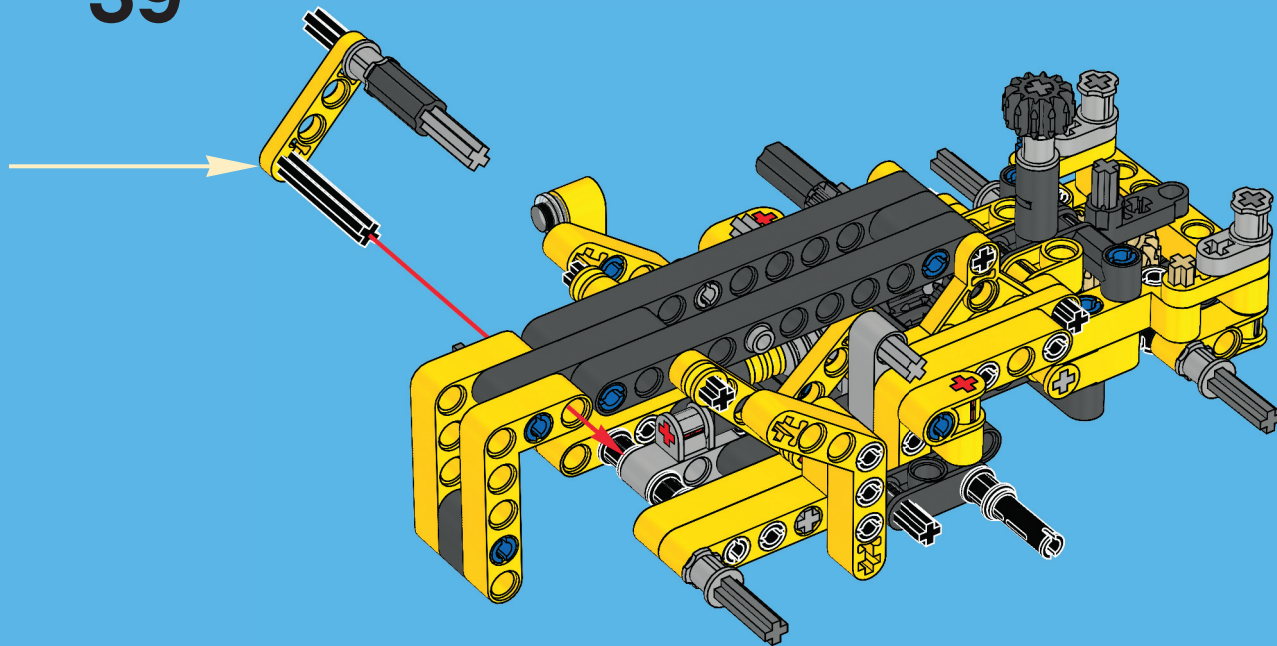



1x

# 40

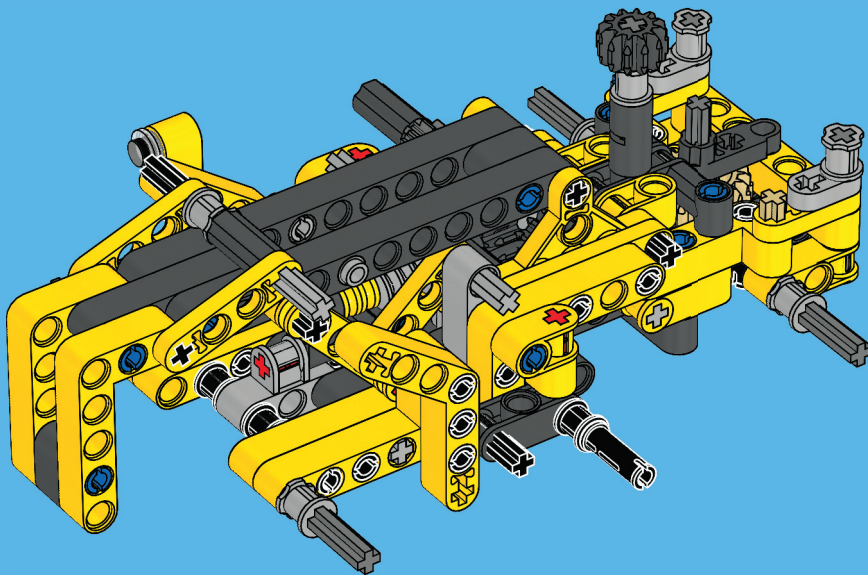

48

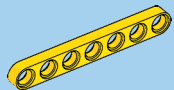

2x

# 41

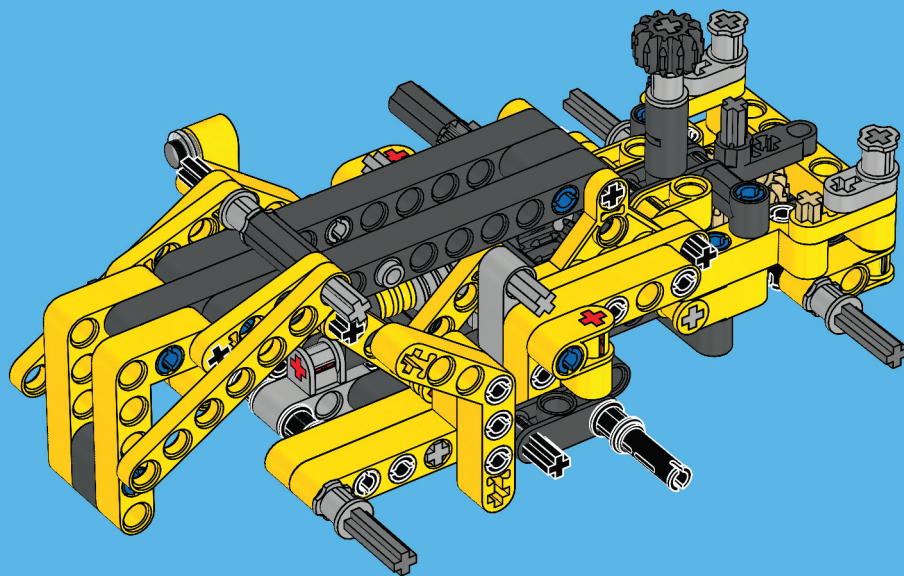



1x



1x

# 42

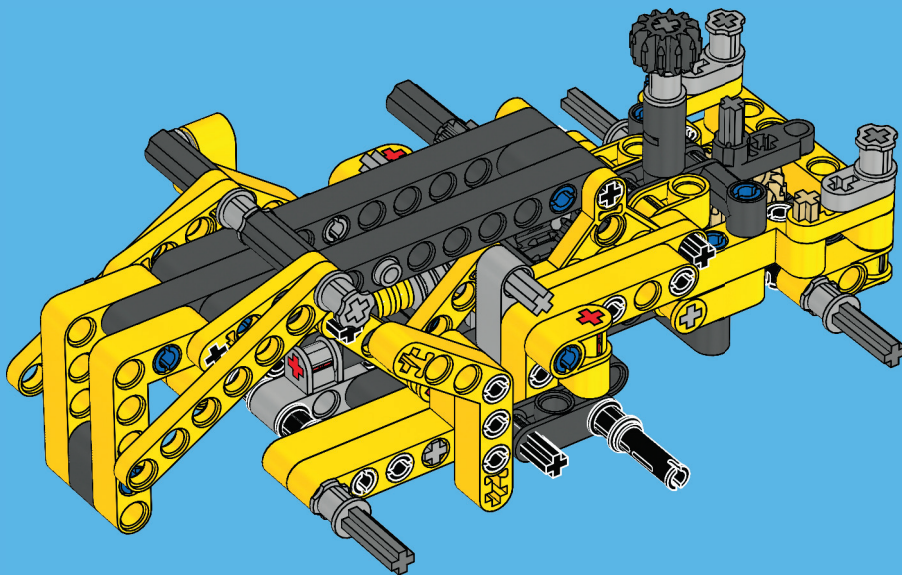

50



# 43

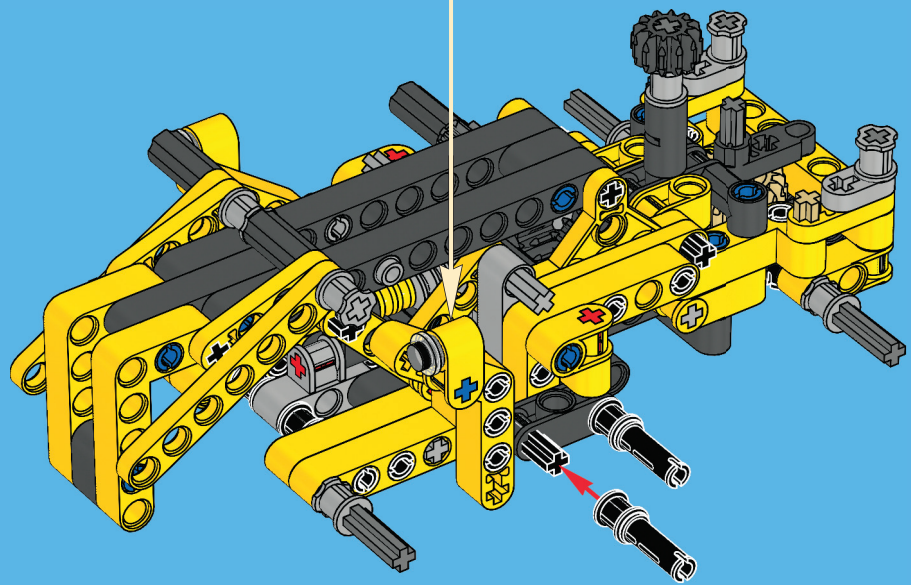

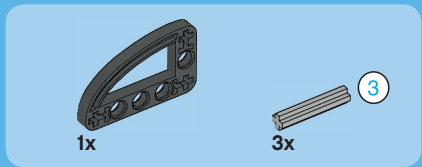
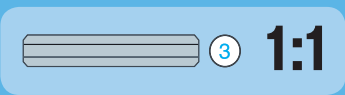
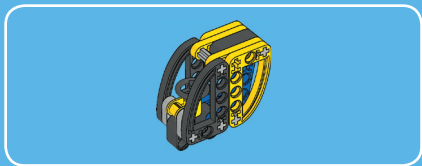

1

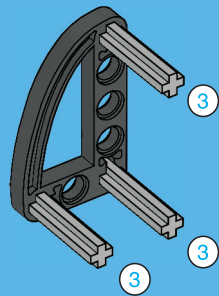

52



2

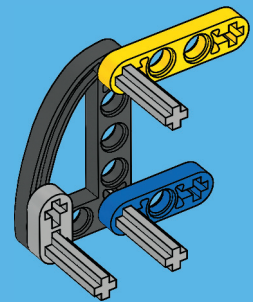

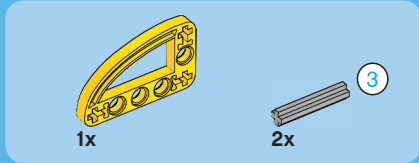

3

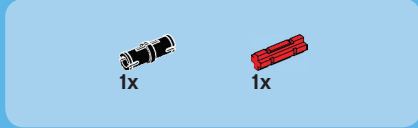
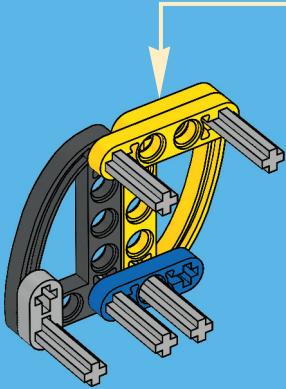
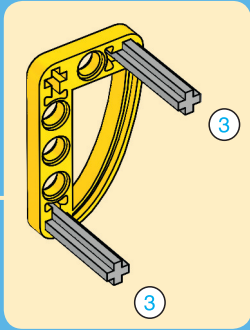

4

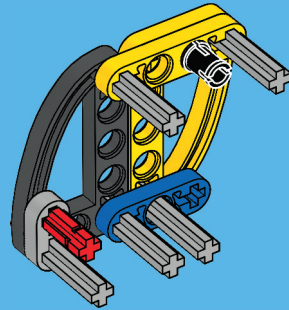





2x

5

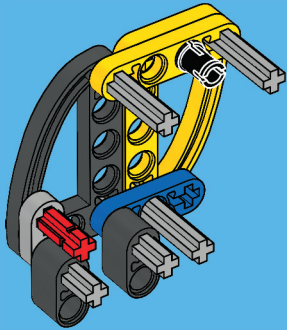

54



1x



1x

6

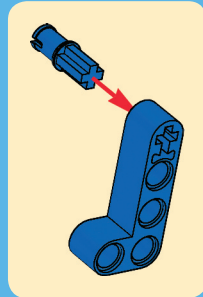
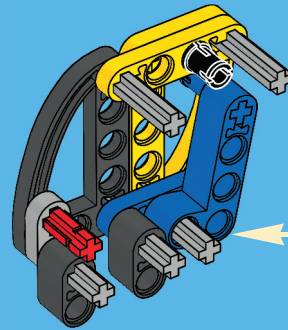



1x



1x



1x

# 7

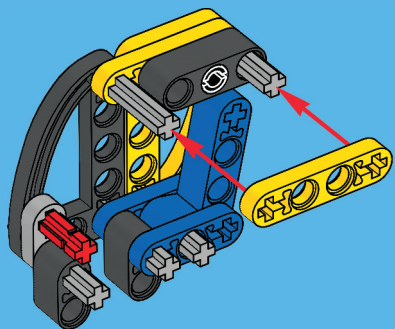

1x



1x



1x

# 8

1



2

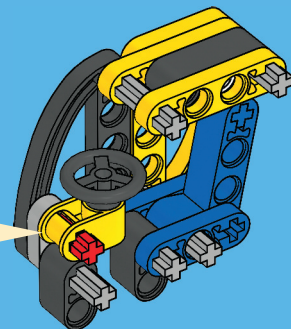



1x

9

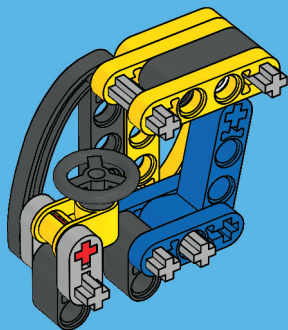

56

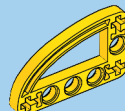

1x

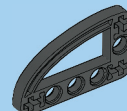

1x

10

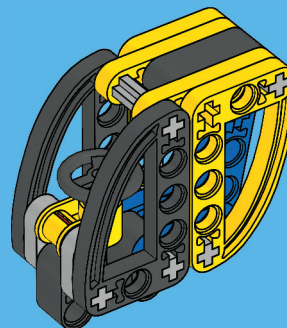

44

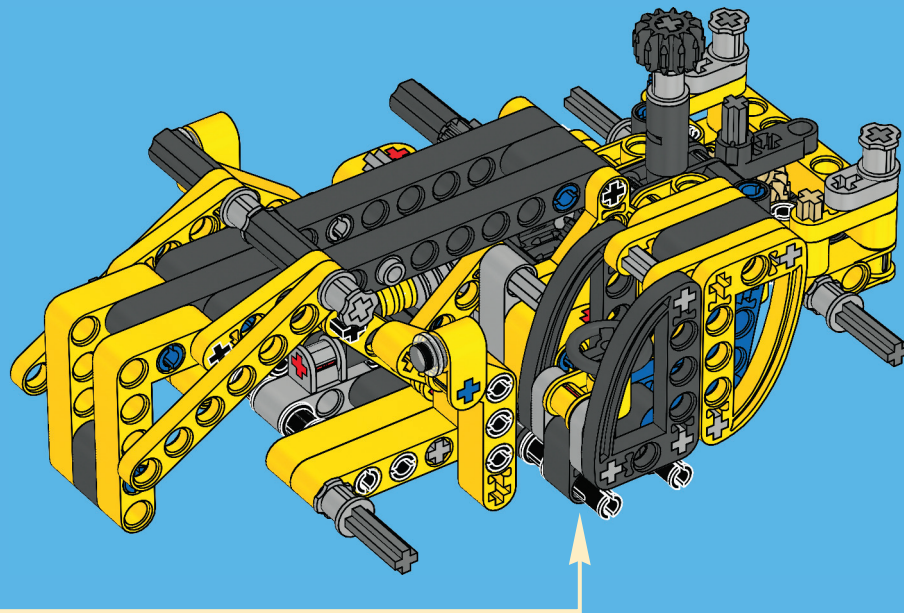



1x

# 45

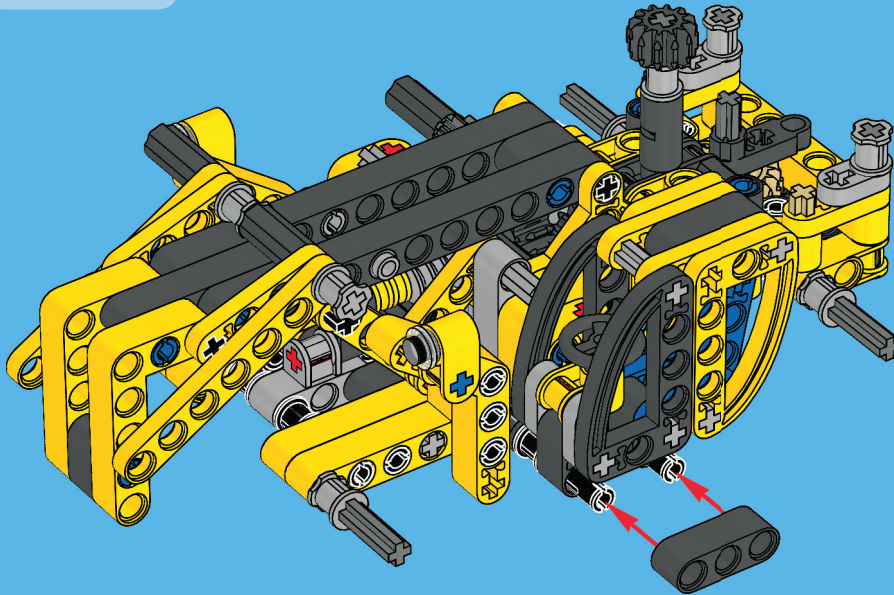

58



4x



4x

# 46

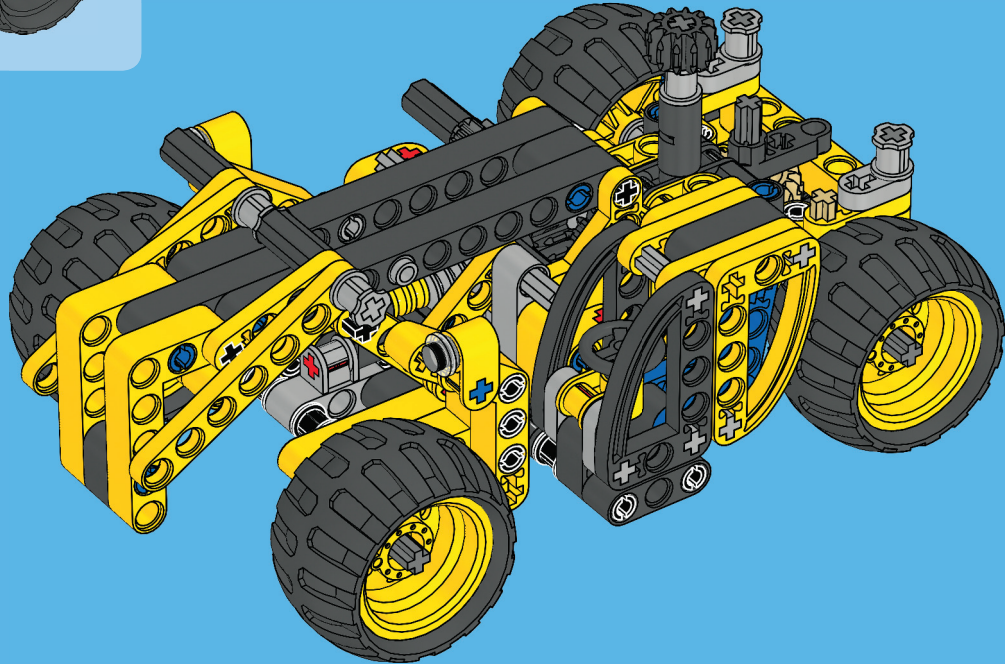

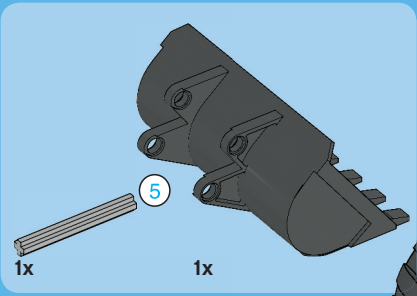

47

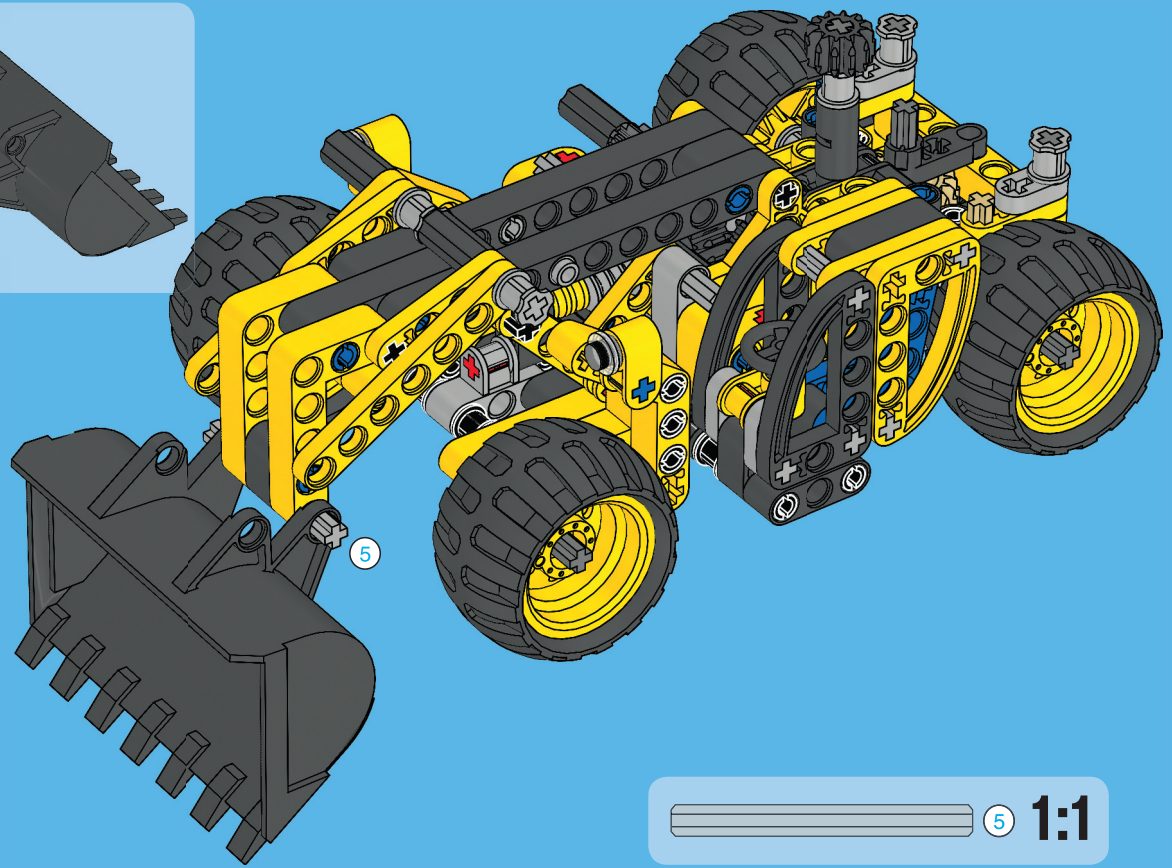

60





# 48

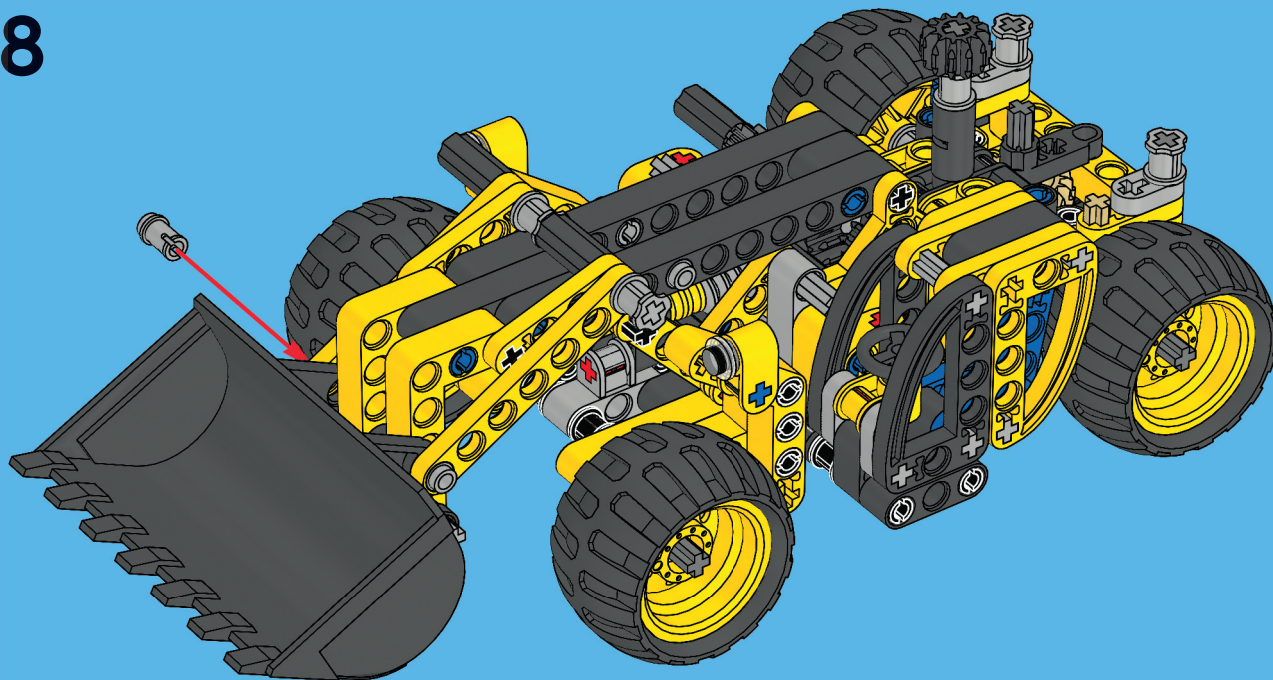





# TECHNIC





# TECHNIC



[LEGO.com/technic](http://LEGO.com/technic)





# TECHNIC



42011



42004



42002



42010



42007





42006

42000



2x  
4211553



4x  
4211655



2x  
4560175



2x  
4538007



4x  
4211741



7x  
4211483



10x  
4211622



2x  
3005740



1x  
4652235



10x  
4211815



2x  
4211639



4x  
4211805



1x  
4535768



2x  
4211510



9x  
4142865



2x  
3005740



7x  
4560177



2x  
4499858



2x  
6012451



1x  
4666579



1x  
4514555



1x  
4514554



23x  
4121715



1x  
6023352



1x  
4652236



4x  
4177431



4x  
4107085



5x  
4512363



1x  
4526982



7x  
4140801



4x  
370526



4x  
370626



4x  
6029578



2x  
4142135



1x  
4153044



4x  
4177431



4x  
4107085



5x  
4512363



1x  
4526982



7x  
4140801



4x  
370526



4x  
370626



4x  
6029578



2x  
4142135



1x  
4153044



1x  
4563044



3x  
4121667



2x  
4128557



1x  
4107783



1x  
4158848



8x  
6006140



2x  
4142822



4x  
4518826



1x  
6023342



2x  
4495934



4x  
4187136



1x  
4174709



2x  
4141628



6x  
4144022



2x  
4500485



4x  
4503425



2x  
4114672



4x  
4490139



4x  
4175441



2x  
4107823



8x  
4199345



2x  
4128554



2x  
6010863



7x  
4173666



8x  
4239601



2x  
4107829



1x  
4168114



10x  
4206482



13x  
4514553



**Customer Service**  
 Kundenservice  
 Service Consommateurs  
 Servicio Al Consumidor  
 LEGO.com/service or dial





1



2



3



www.LEGOclub.com/Max

LEGO club

FREE\*! GRATIS! GRATUIT!

\*Paid subscription in Australia and New Zealand.
\*Abonnement payant en Australie et Nouvelle-Zélande.

©2013 The LEGO Group.





# WIN!

Go to [www.LEGOsurvey.com/product](http://www.LEGOsurvey.com/product)  
to fill out a survey for a chance  
to win a cool LEGO® Product.

No purchase necessary.

Open to all residents where not prohibited.

## [www.LEGOsurvey.com/product](http://www.LEGOsurvey.com/product)

### GEWINNE!

Nimm an der Umfrage auf [www.LEGOsurvey.com/product](http://www.LEGOsurvey.com/product) teil und hab die Chance ein cooles LEGO® Produkt zu gewinnen!  
Die Teilnahme am Gewinnspiel führt zu keinerlei Kaufverpflichtungen. Teilnahme in allen nicht ausgeschlossenen Ländern möglich.

### WIN!

Ga naar [www.LEGOsurvey.com/product](http://www.LEGOsurvey.com/product), vul een enquêteformulier in en maak kans op een cool LEGO® product.  
Geen aankoopverplichting. Iedereen mag deelnemen, uitgezonderd ingezetenden van landen waar een enquêteverbod geldt.

### GAGNE !

Visite [www.LEGOsurvey.com/product](http://www.LEGOsurvey.com/product) pour répondre à un questionnaire et avoir une chance de gagner un produit LEGO® très cool !  
Aucune obligation d'achat.  
Ouvert à tous les résidents des pays autorisés.

### 当てよう!

[www.LEGOsurvey.com/product](http://www.LEGOsurvey.com/product) にアクセスして、アンケートにご記入ください。  
当選者にはレゴ®製品を差し上げます。  
お買い上げの必要はありません。  
禁止されていない限り、すべての皆様にご利用いただけます。



[LEGO.com](http://LEGO.com)

6033742 / 6033743

LEGO and the LEGO logo are trademarks of the/sont des marques de commerce de/son marcas registradas de LEGO Group. ©2013 The LEGO Group.