

**BMW
MOTORRAD**

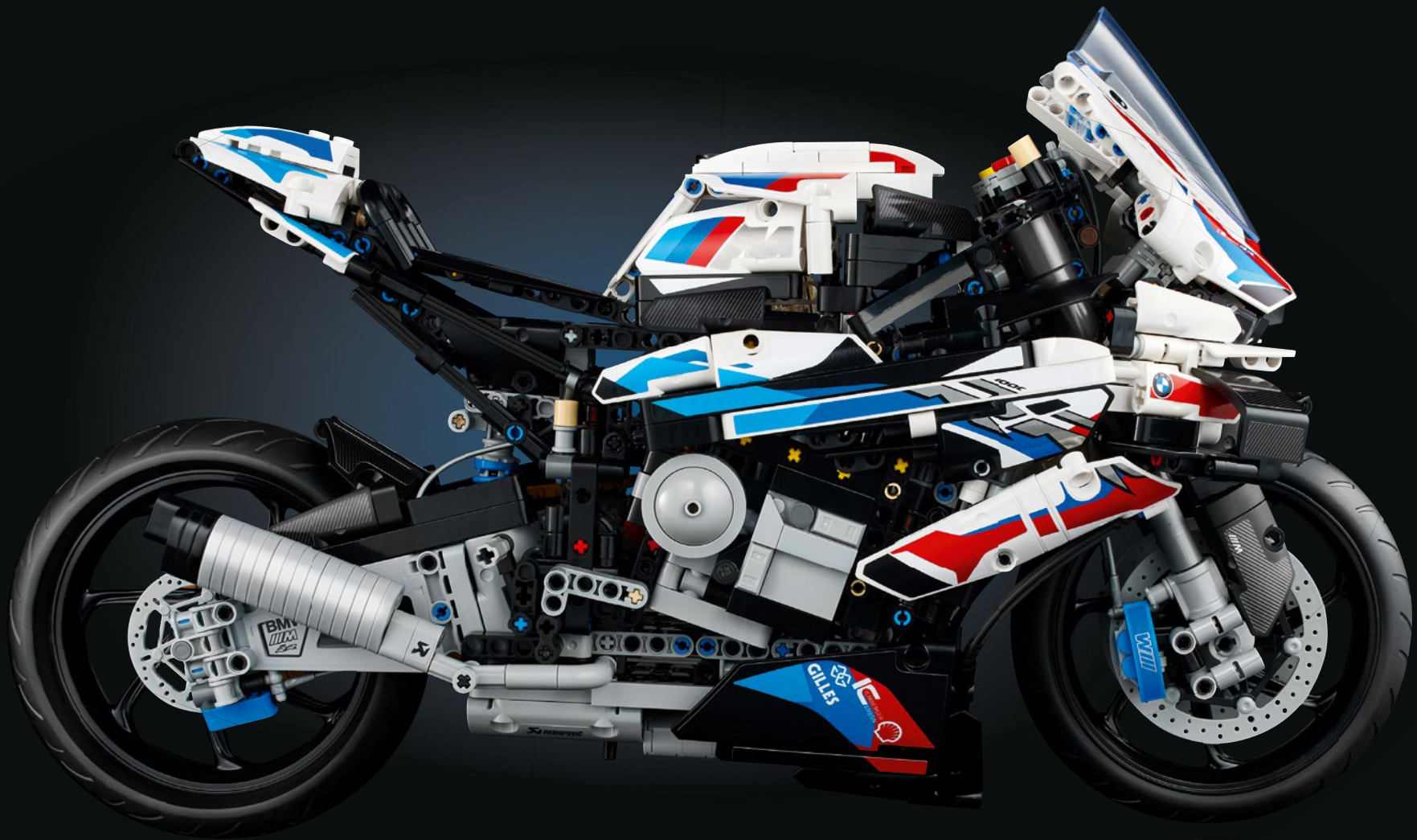

Booklet available in English on
Heft in deutscher Sprache erhältlich auf
Livret disponible en français sur
Libretto disponibile in italiano su
Folletto disponible en español en
如需中文版手册, 请访问







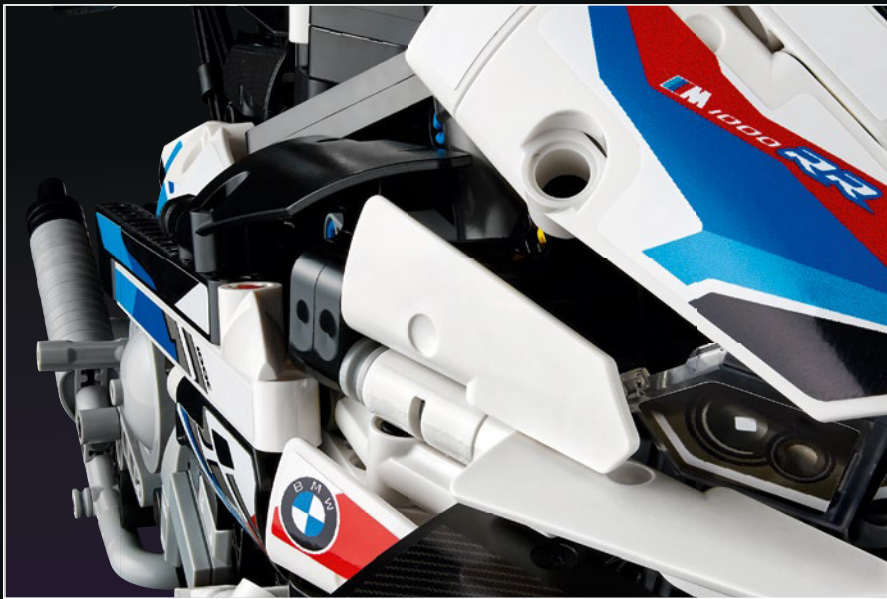
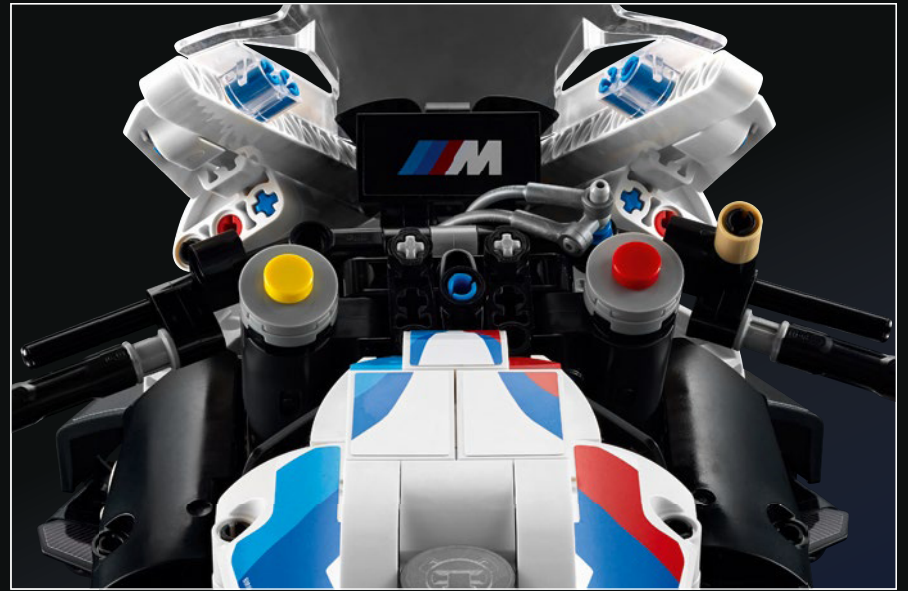

BMW M 1000 RR

When BMW Motorrad's in-house performance experts announced the first-ever M-developed motorcycle, the BMW M RR, everyone knew that the result was going to be something special. In the same way, the LEGO® Technic team realised it would take something never seen before to pay true tribute to the M RR. The result is both a motorcycle and a Technic model that are state-of-the-art within their respective fields.



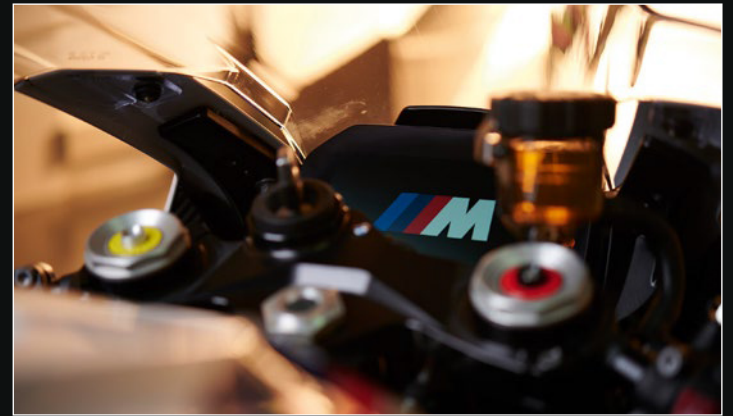

THE PINNACLE OF PERFORMANCE

The quest for enhanced performance on both racetrack and road is what defines this M version of a high-performance motorcycle. With the original RR superbike as the perfect foundation, the BMW Motorrad team set about coaxing more power out of the water-cooled 999-cc inline four-cylinder engine, while also introducing design upgrades like carbon fibre wheels and titanium exhaust system to reduce overall weight.





A MATTER OF SCALE

The first challenge the LEGO® Technic designers faced was to set the scale of the model. Too small and it would be difficult to replicate the many features and functions of the real M RR. Too big and it would challenge the Technic building system. With a 1:5 scale, it became the largest Technic motorcycle model ever created. The Technic team worked closely with the designers and engineers at BMW Motorrad to ensure the LEGO Technic version was as close to the real M RR as possible.

SAMUEL TACCHI
Designer
LEGO® Technic





“

**IT TOOK ME BACK TO WHEN I WAS
DESIGNING MOTORCYCLES.”**

Samuel Tacchi



With a background in motorcycle design and a huge passion for riding them as well, LEGO® Technic designer Samuel Tacchi was the natural choice to lead this project.

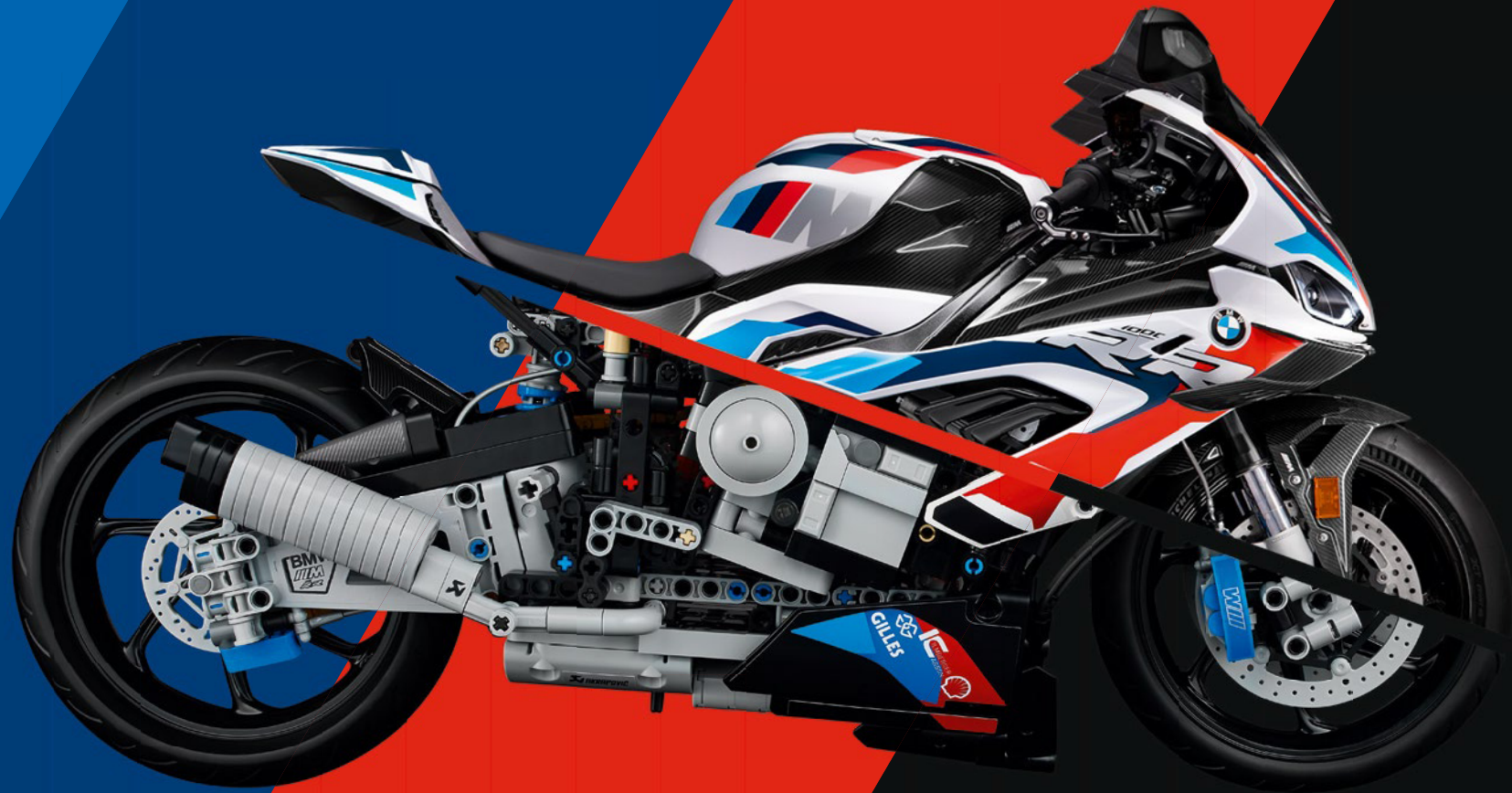



PUSHING THE TECHNIC BUILDING SYSTEM

The Technic version of the M RR needed the design of eight new pieces and Senior Designer Daniel Sri Sudarsono oversaw this process. It started with the new front and rear suspension setup needed to support the 1.4 kg (3 lbs.) weight of the model. New rims, disc brakes and a transparent windscreen quickly followed, all of which had to be tried and tested before being approved for use in the final model.

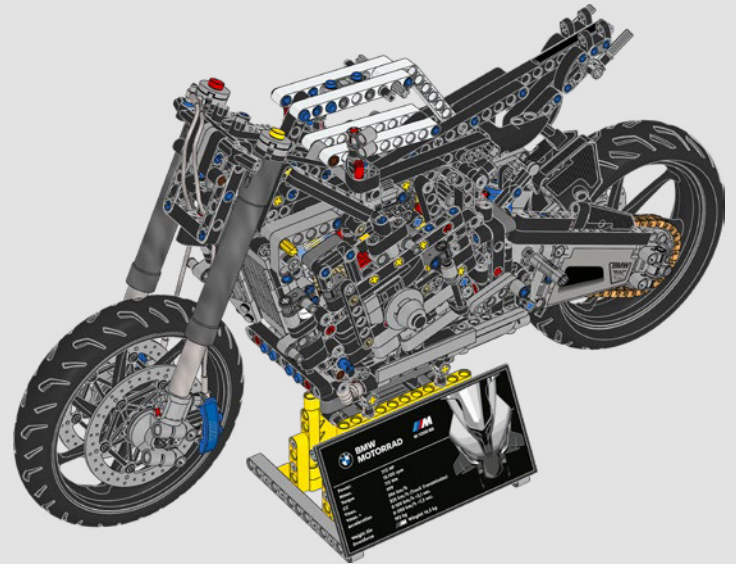
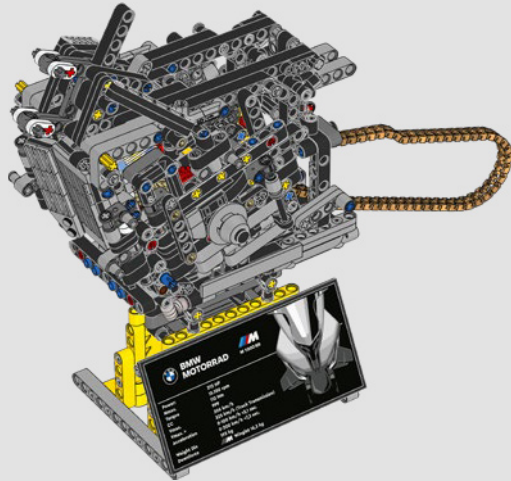
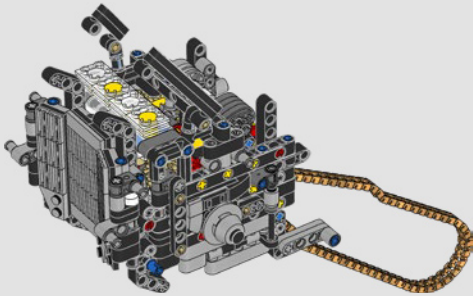
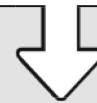
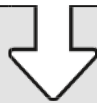
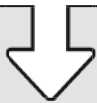

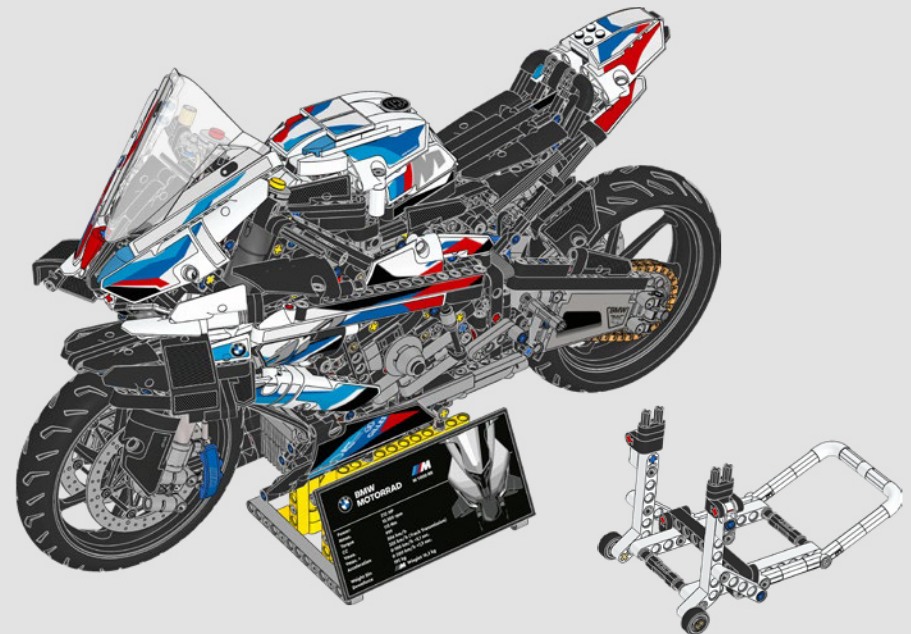
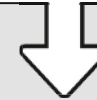
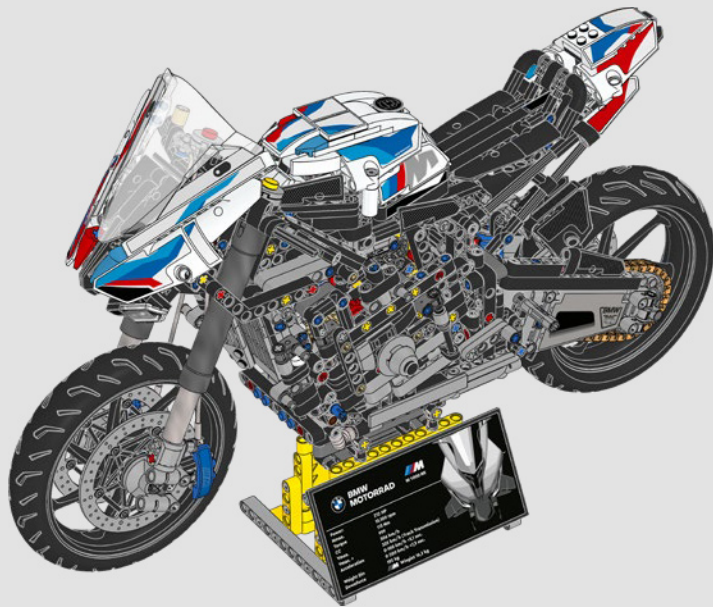
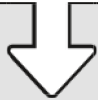

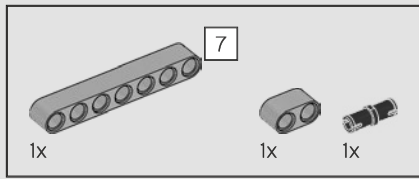
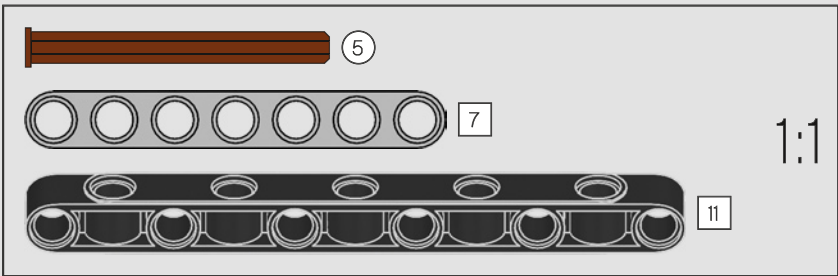
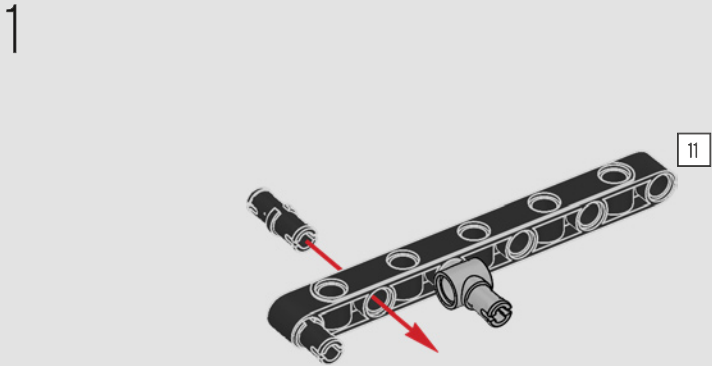
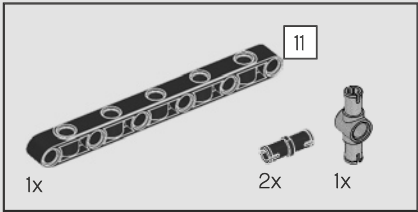
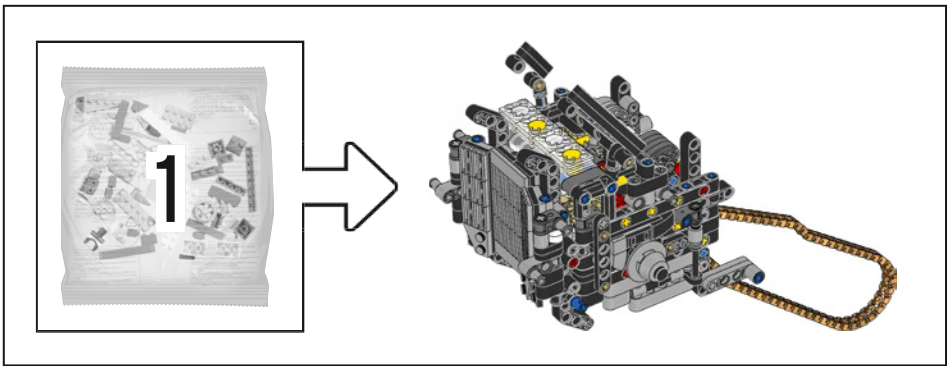

2

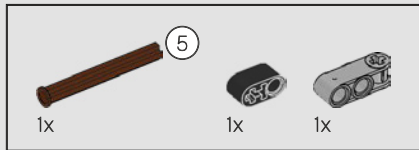
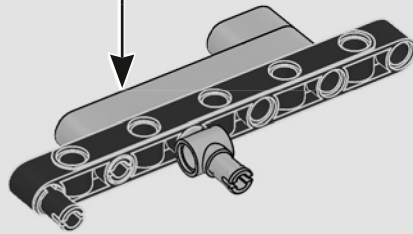
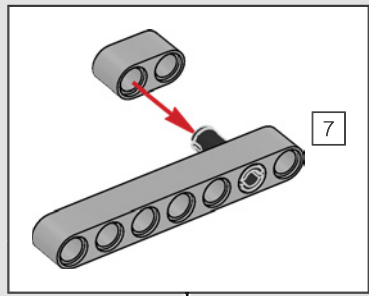

3

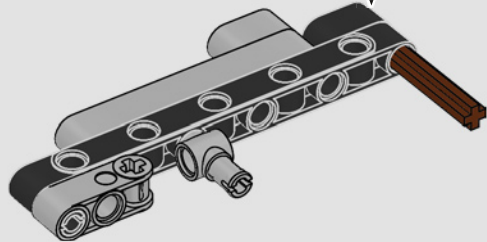
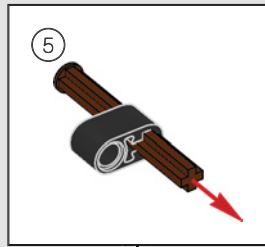



4

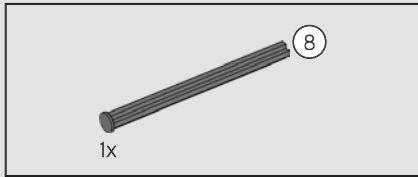
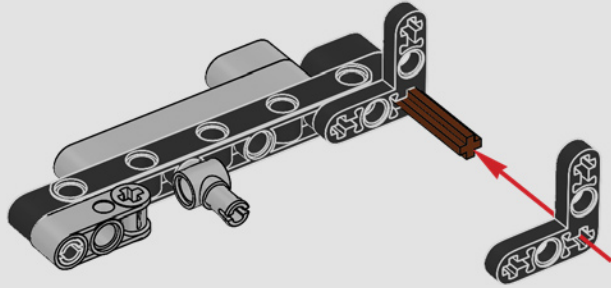

5

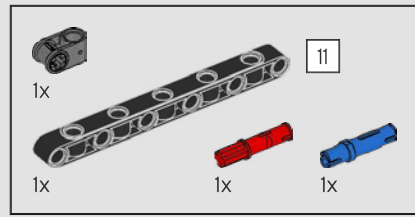
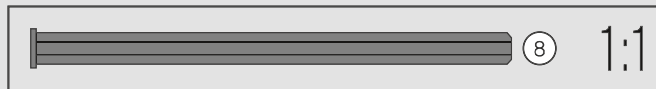
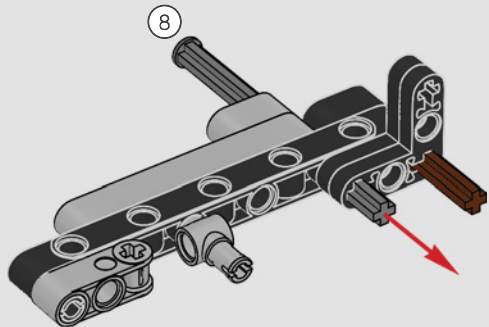

6

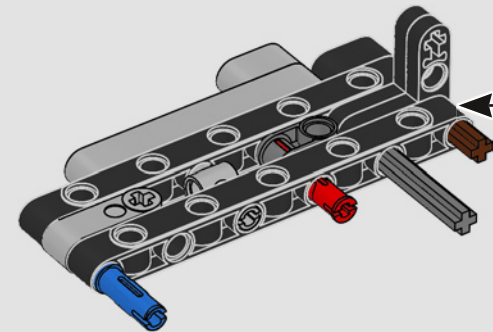
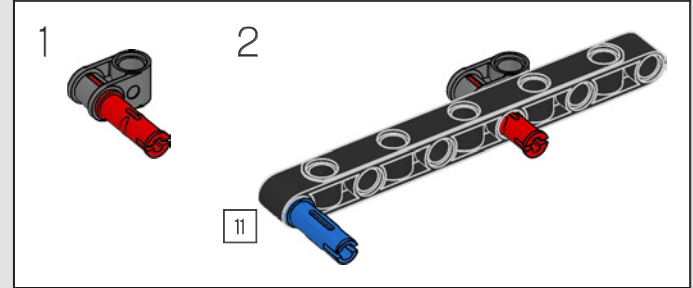

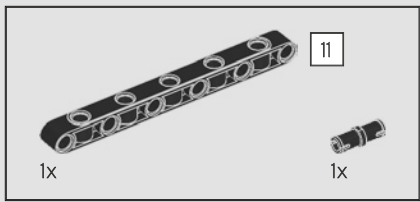

7

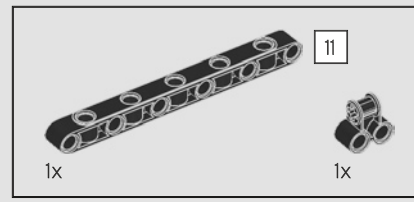
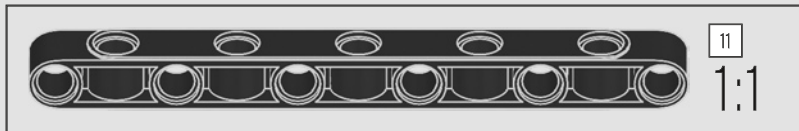
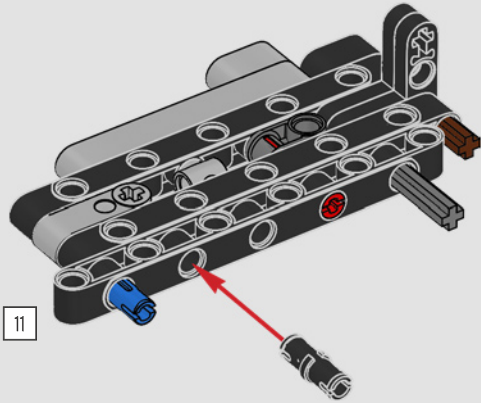

8

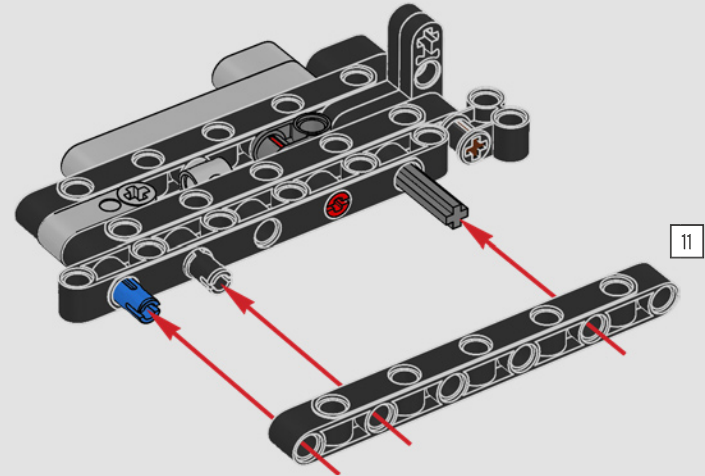

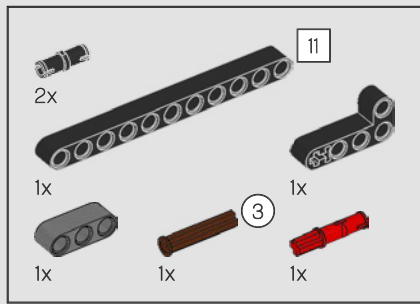

9

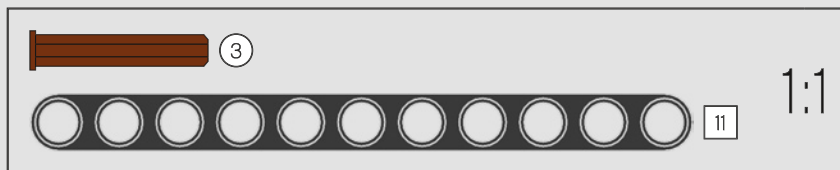
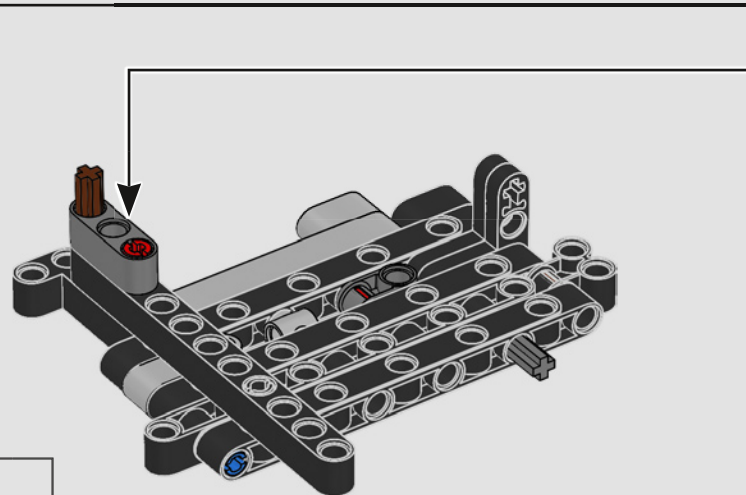
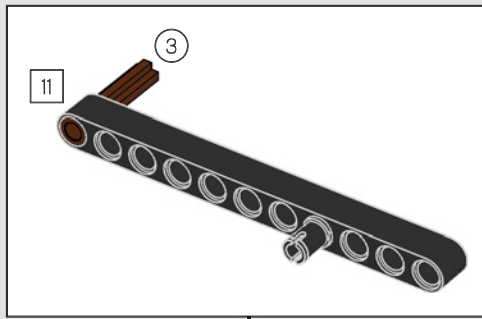
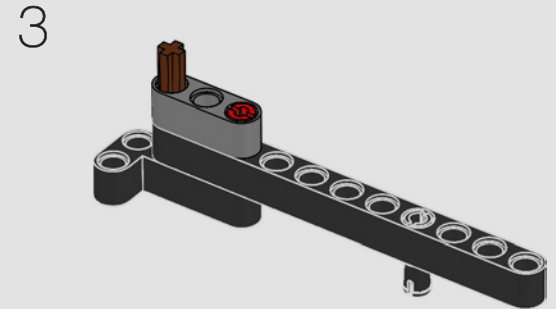
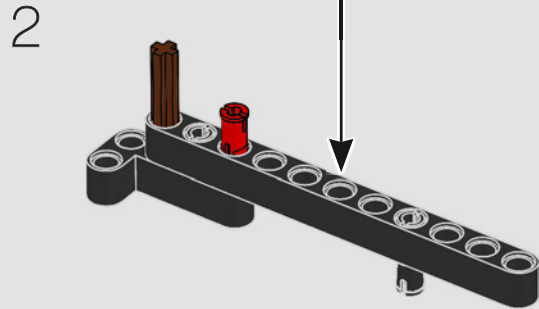
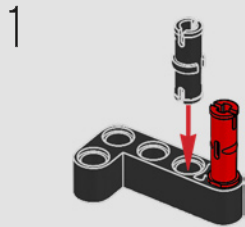

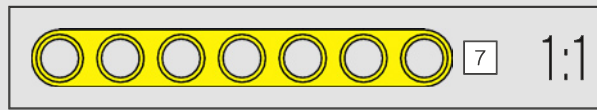
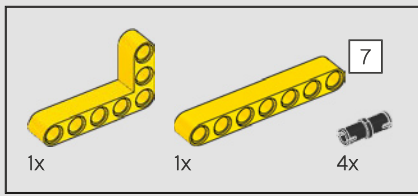

10

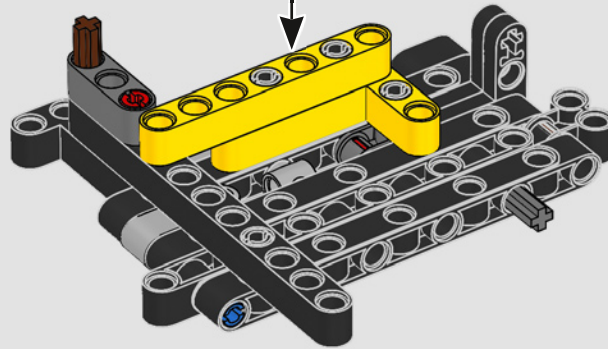
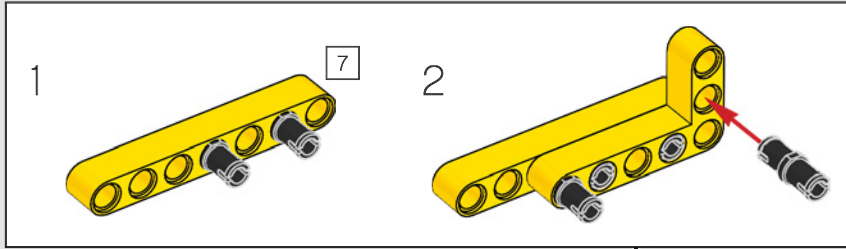

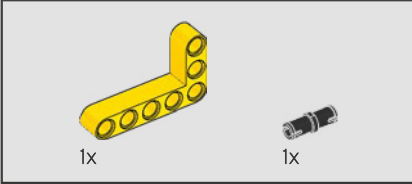
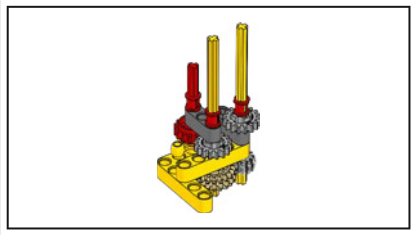

11

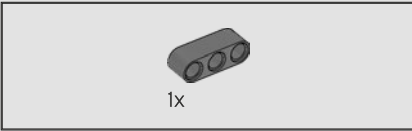
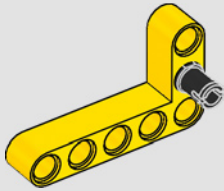

12

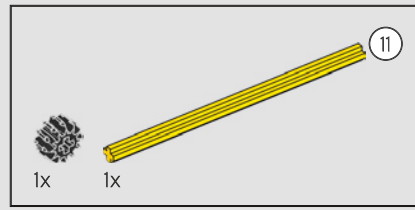
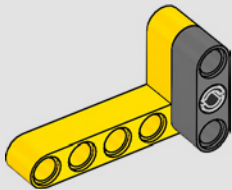

13

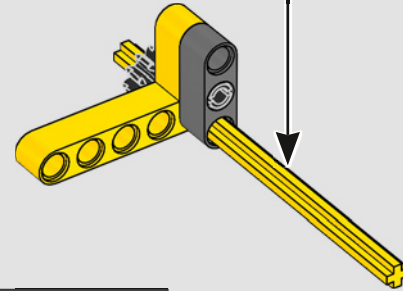
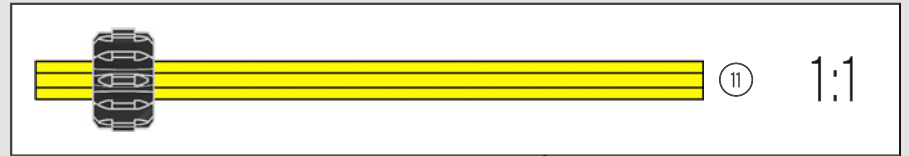

14

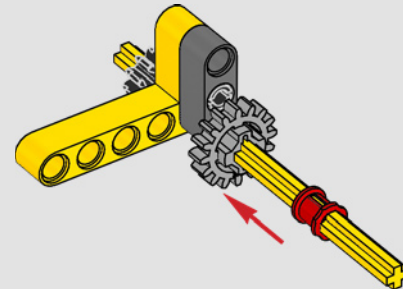

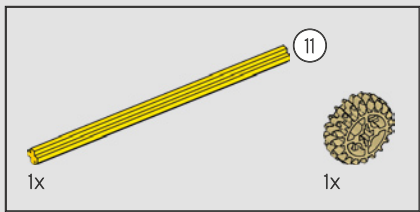

15

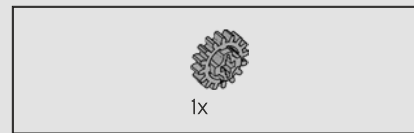
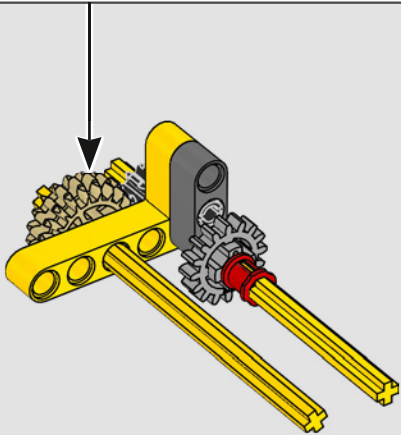
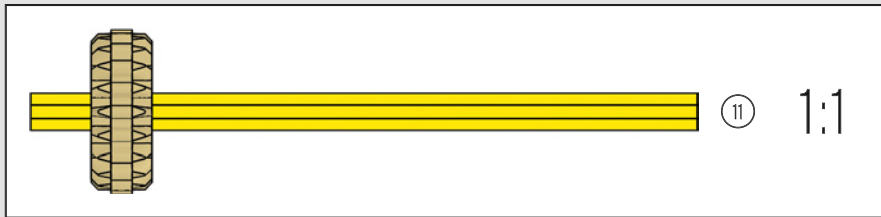

16

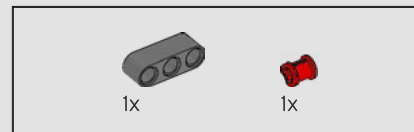
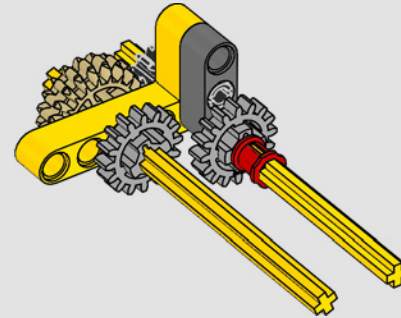

17

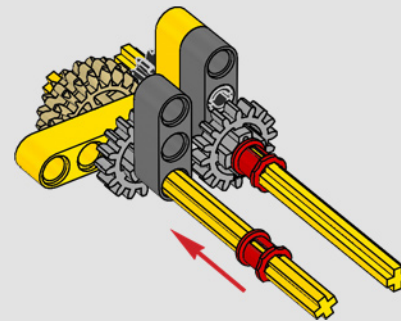

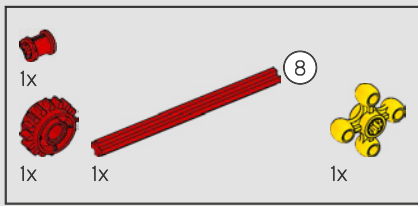

18

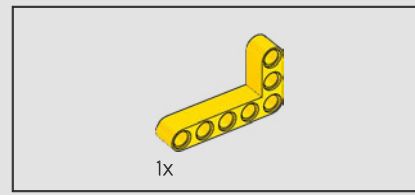
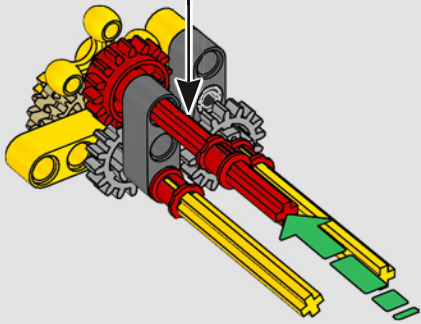
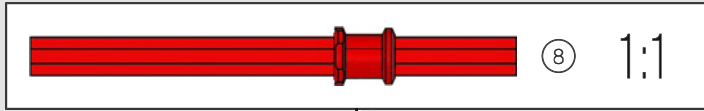

19

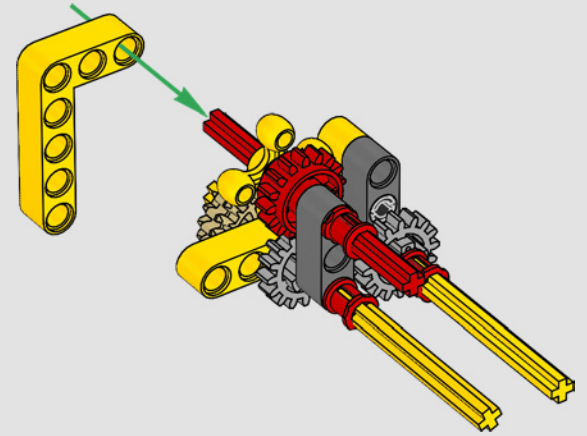

20

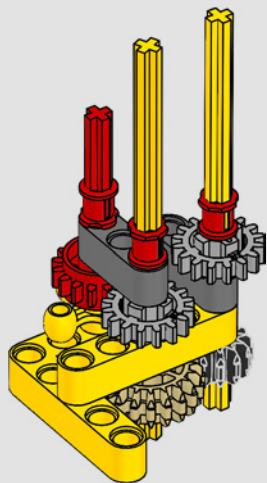

21

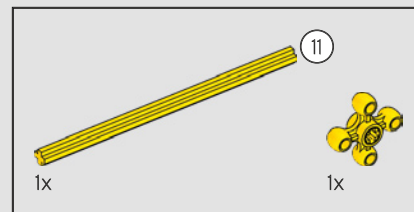
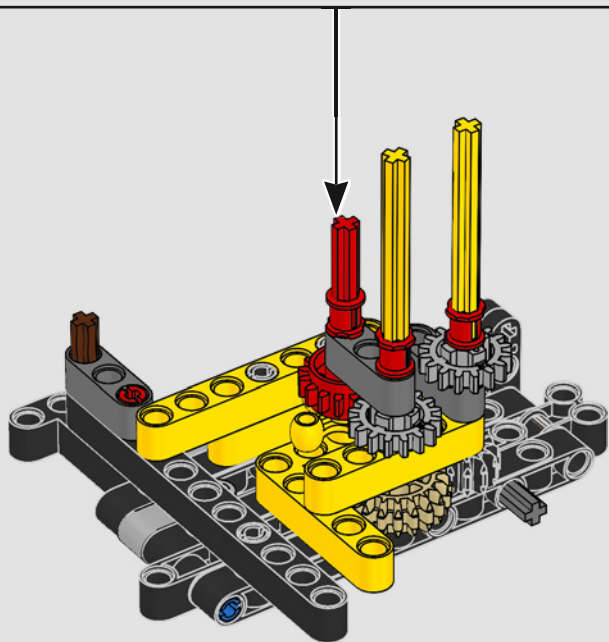

22

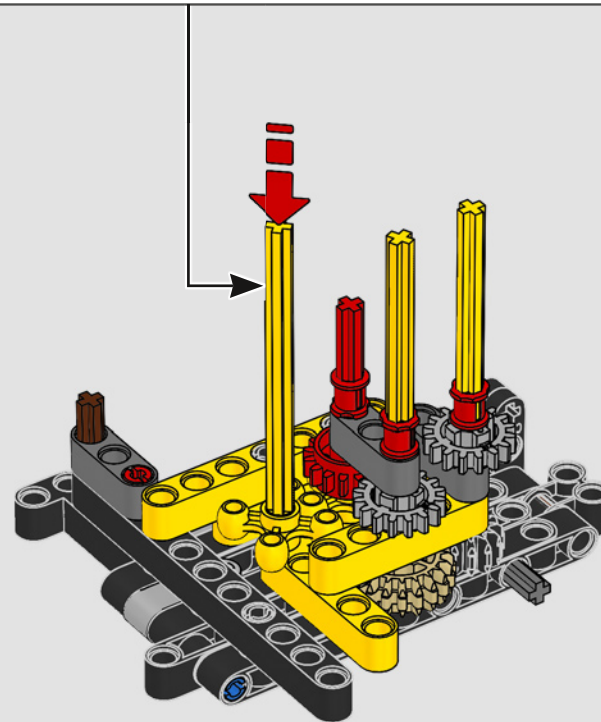
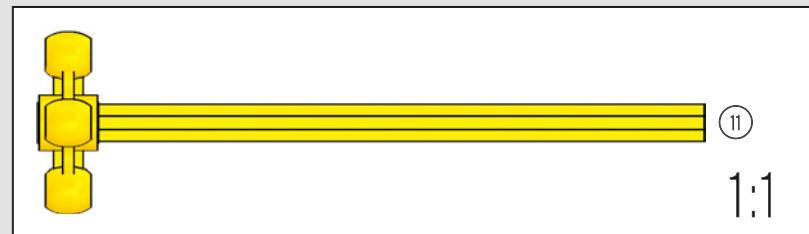

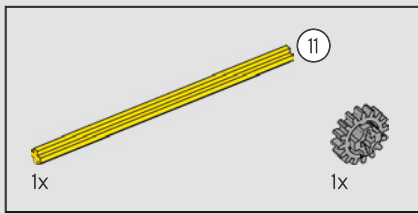

23

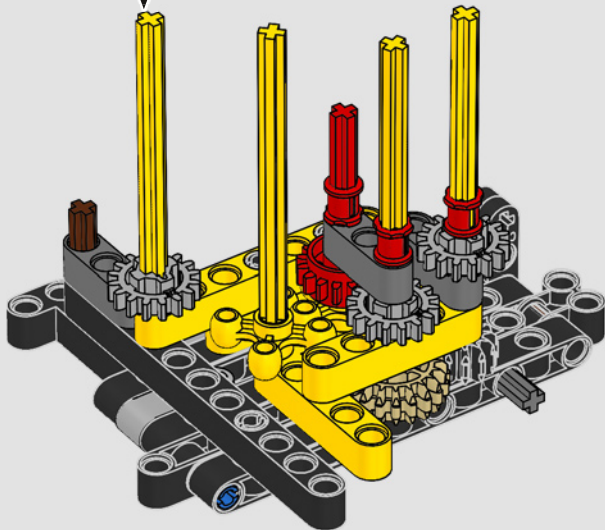

24

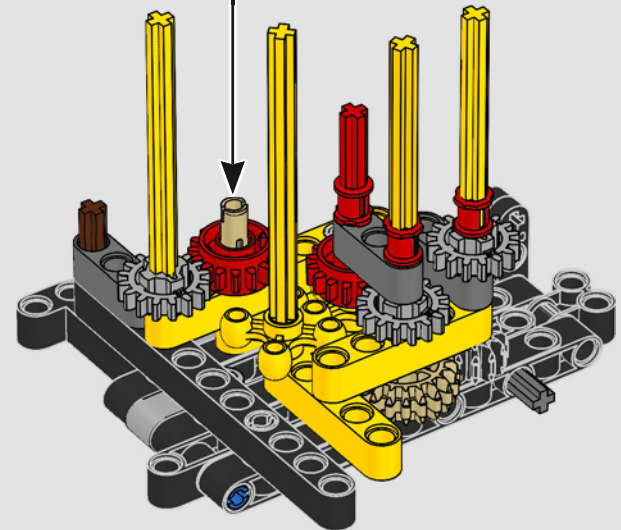
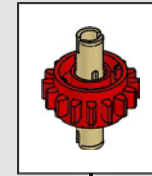

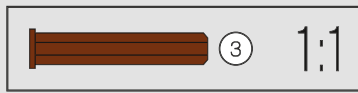
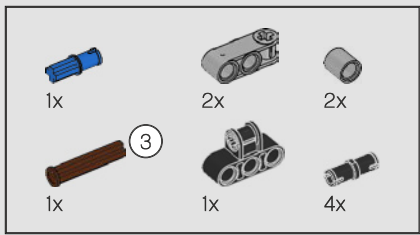

25

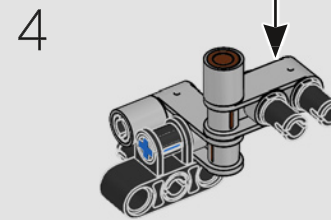
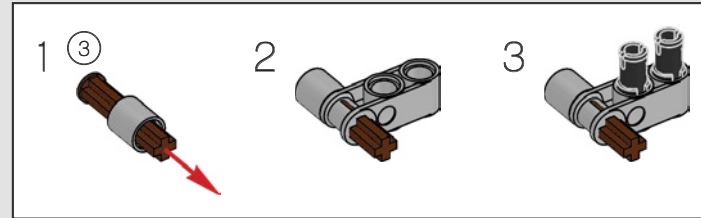
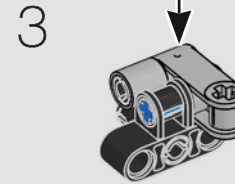
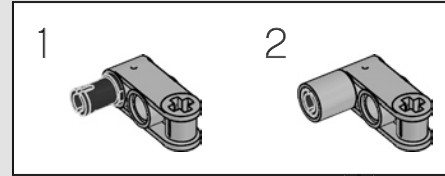
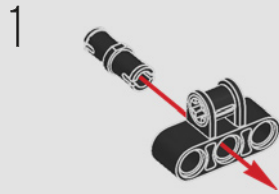

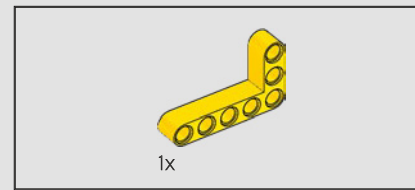
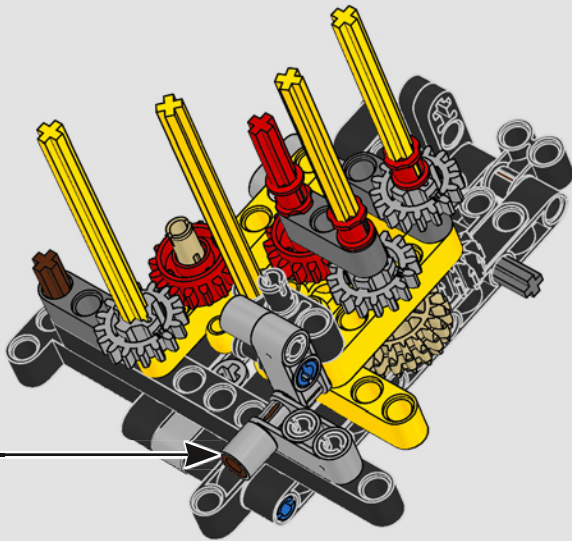

26

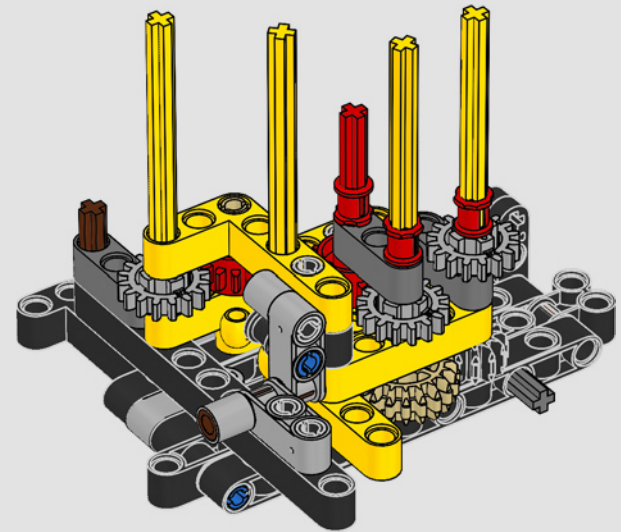

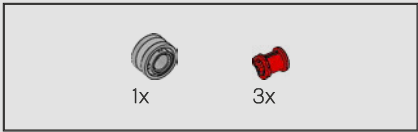

27

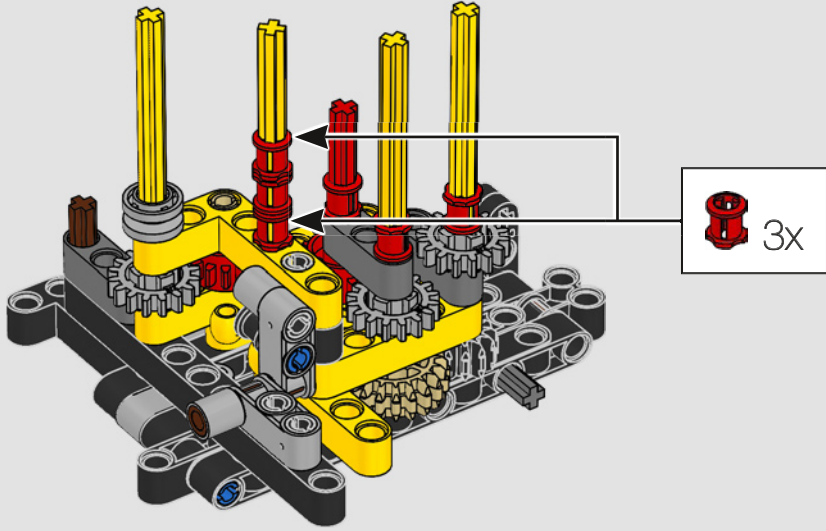

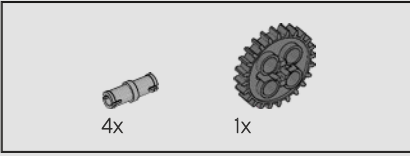
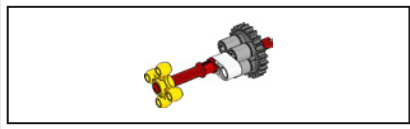

28

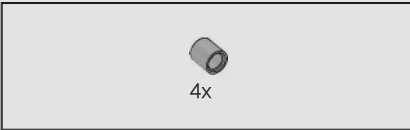
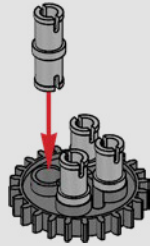

29

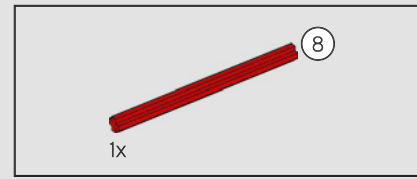
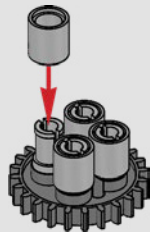

30

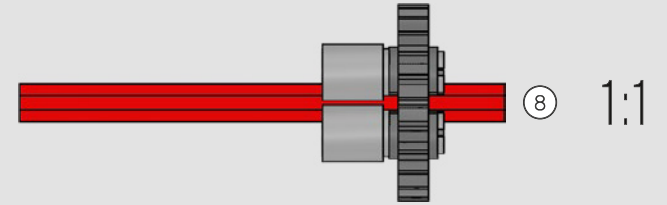

31

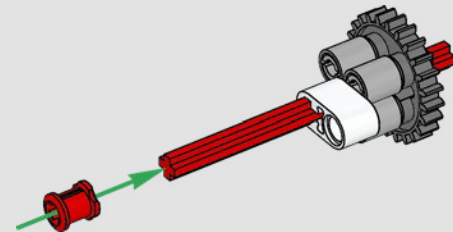



1x

32

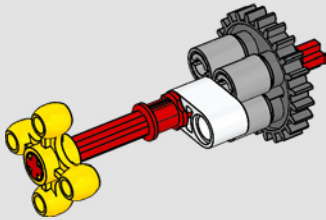

33

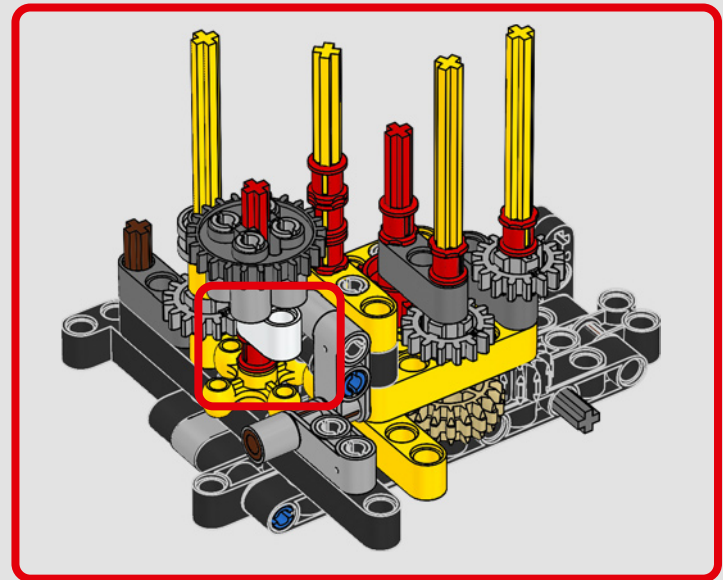
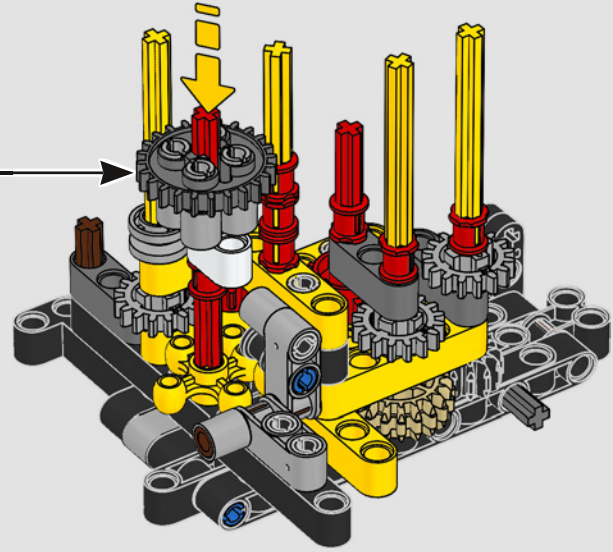

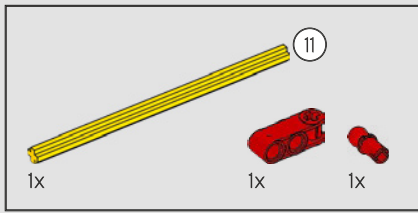

34

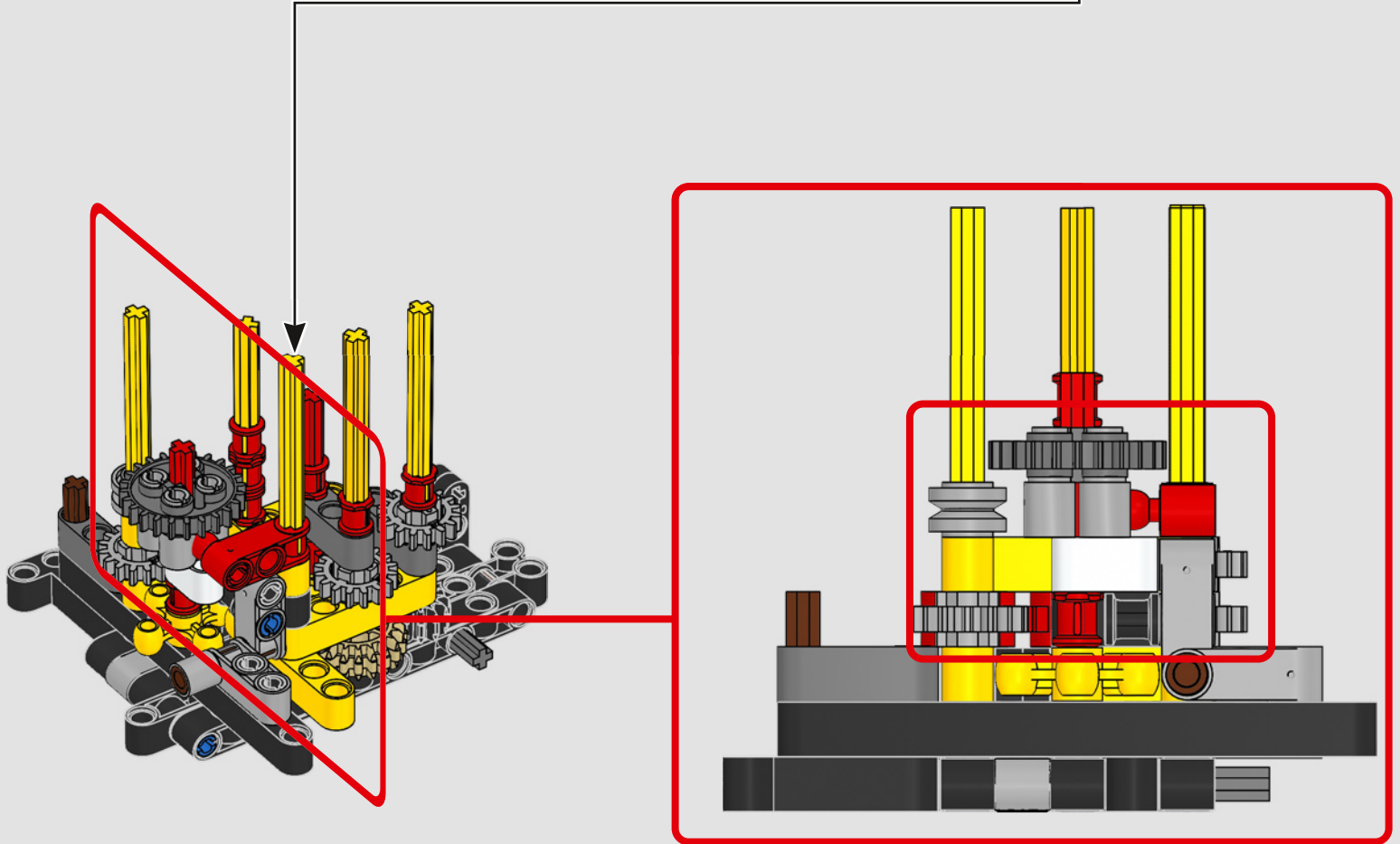
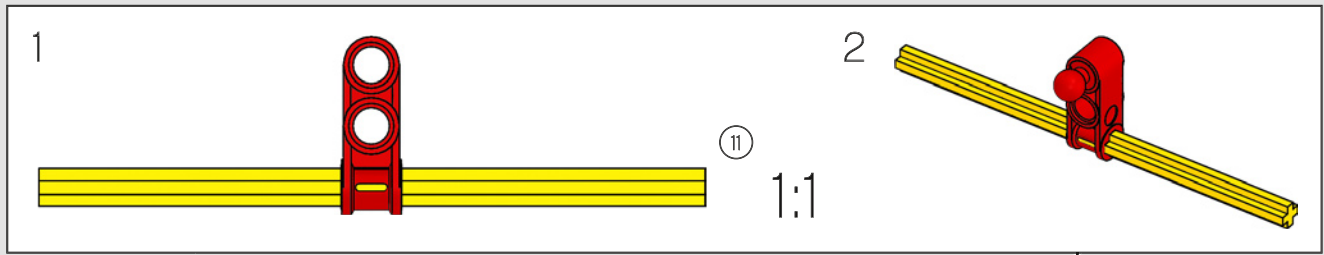

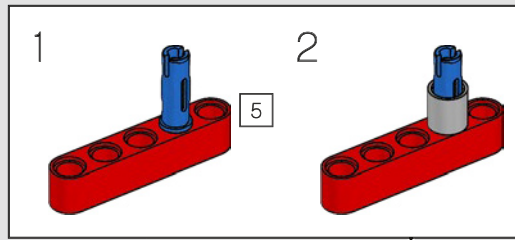
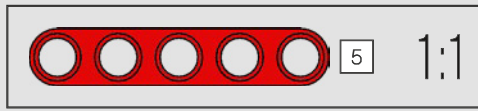
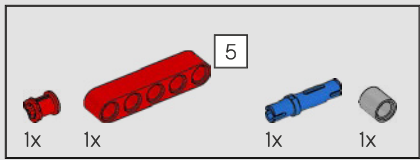

35

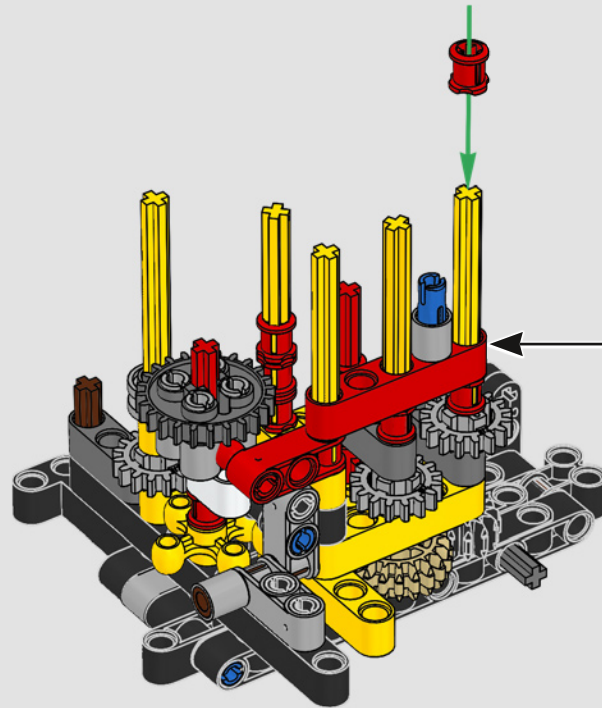

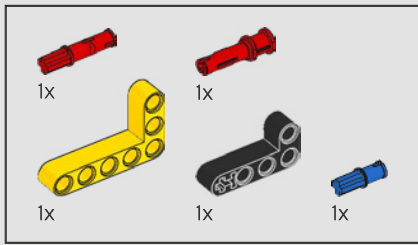

36

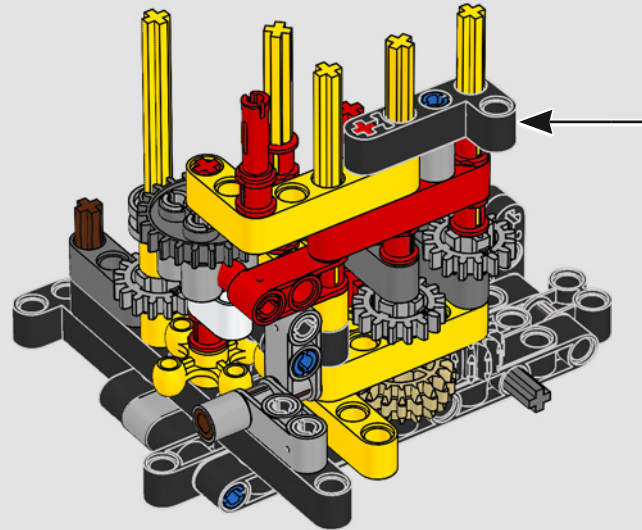
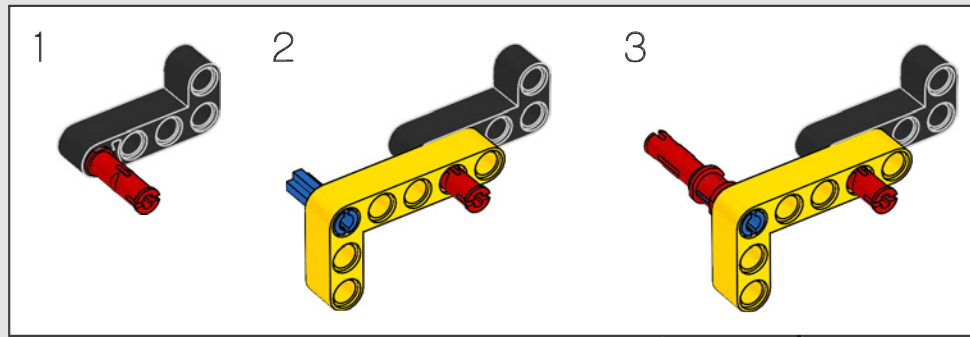

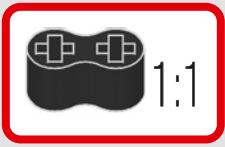
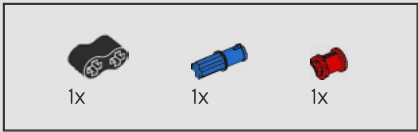

37

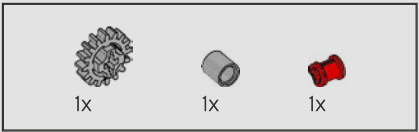
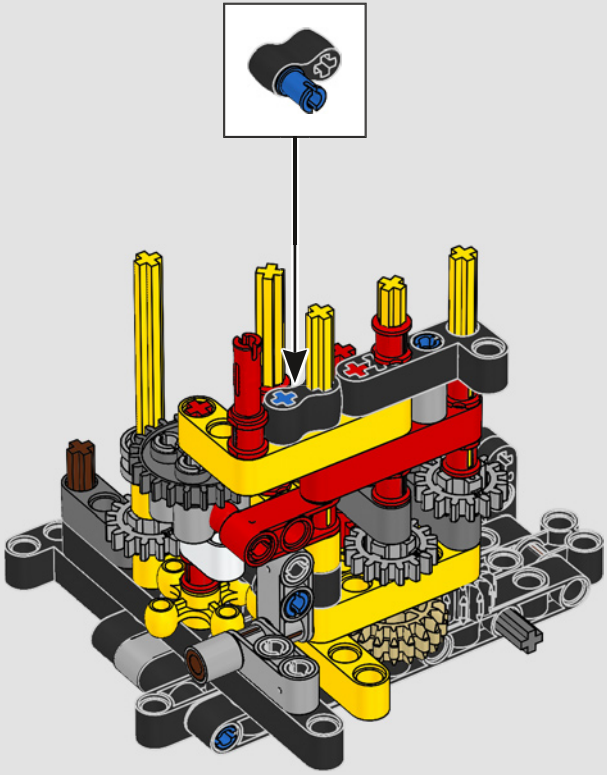

38

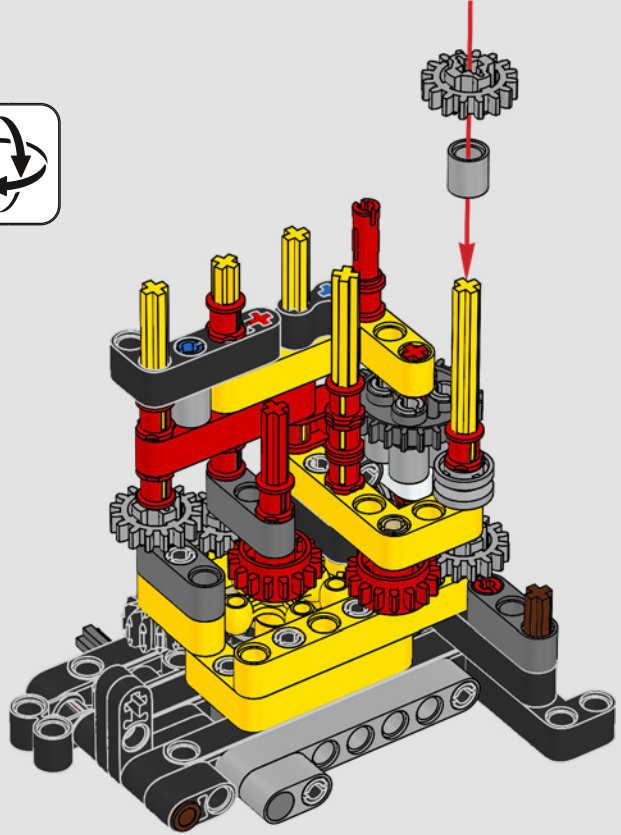

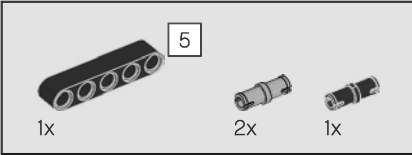
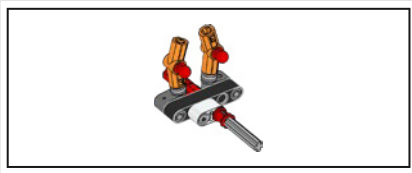

39

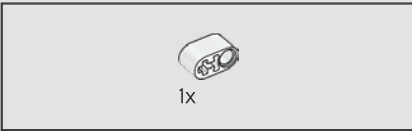
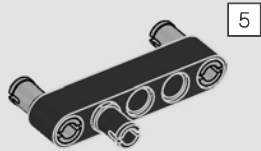

40

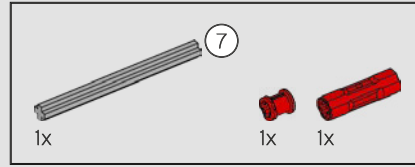
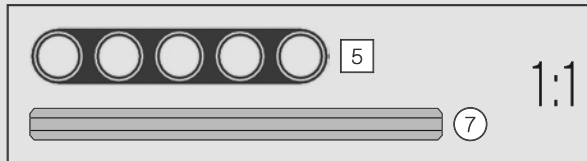

41

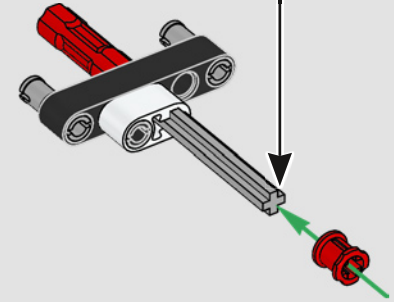
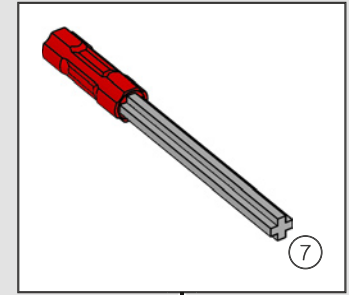

42

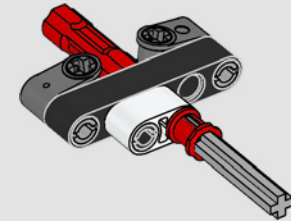

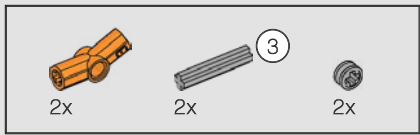

43

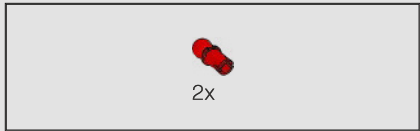
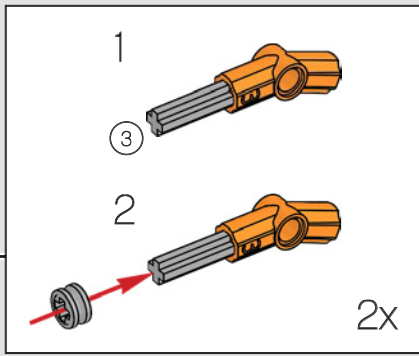
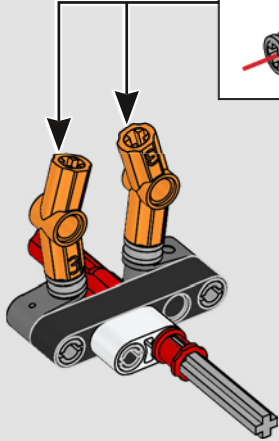

44

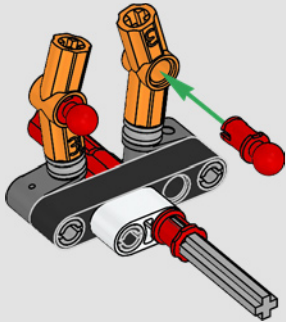

45

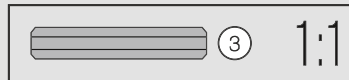
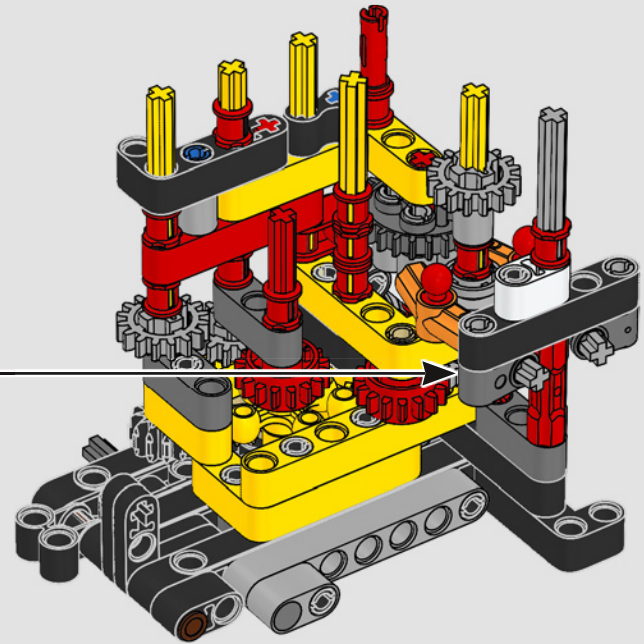



46

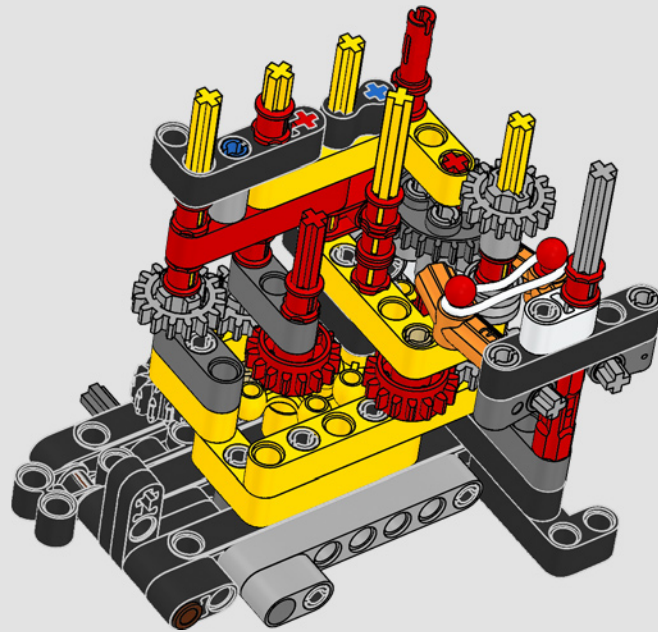

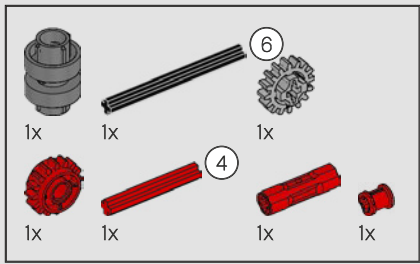

47

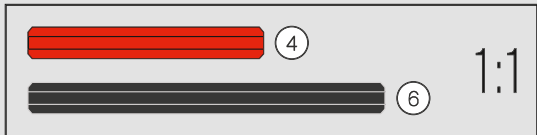
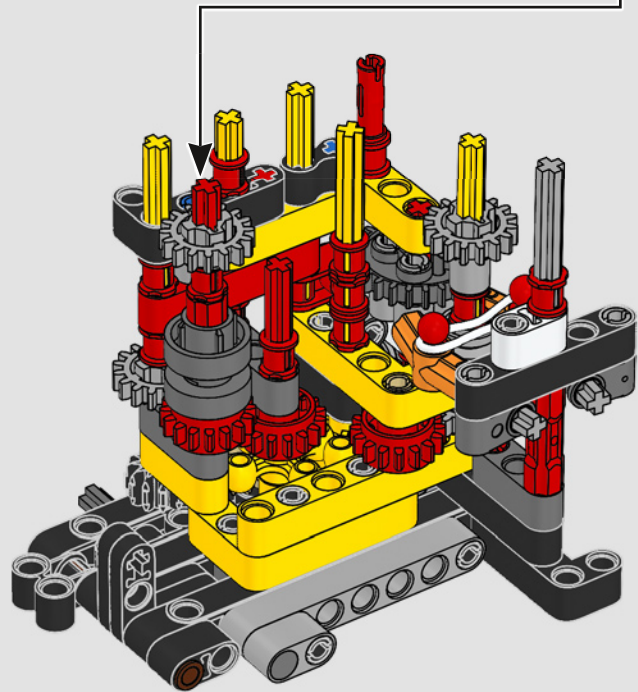
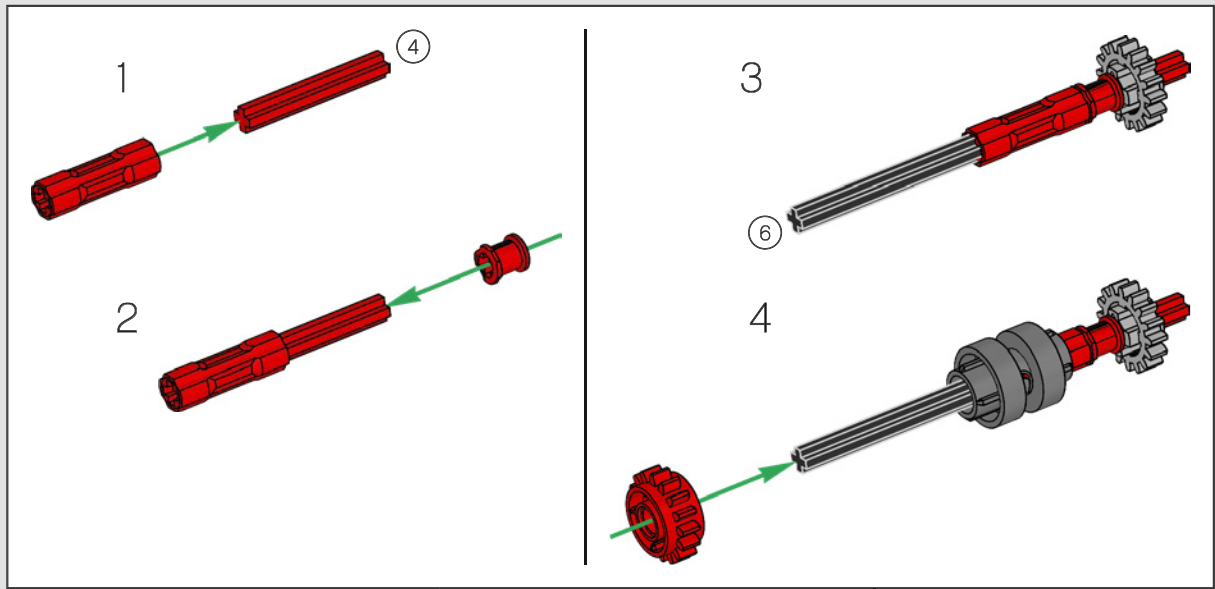



48

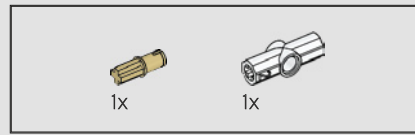
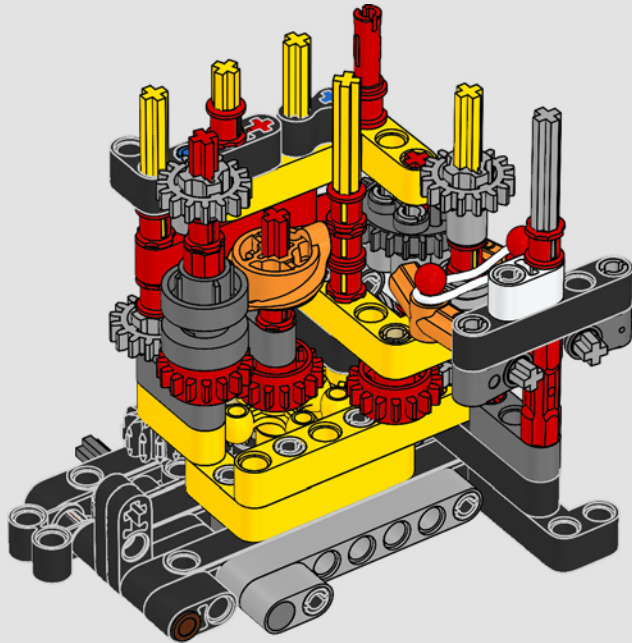
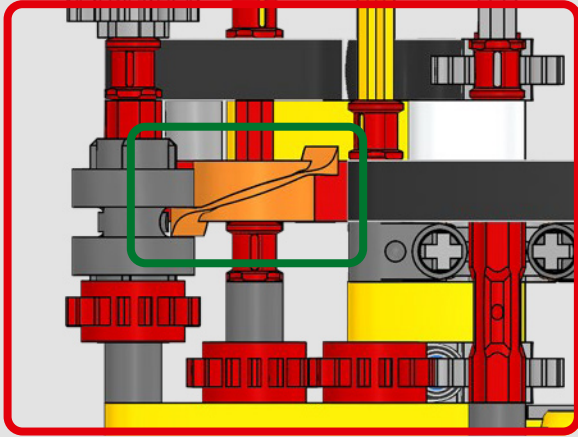

49

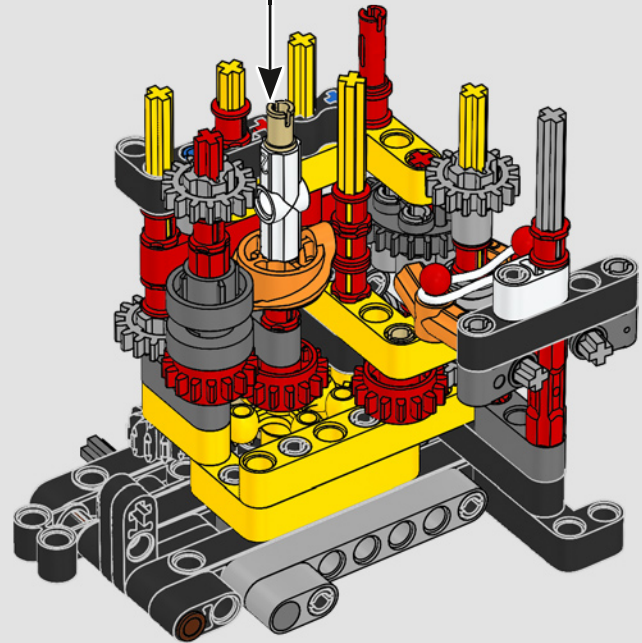
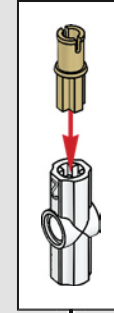



50

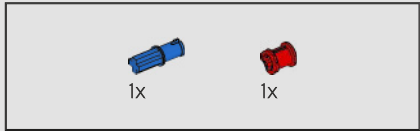
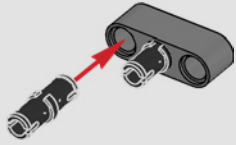

51

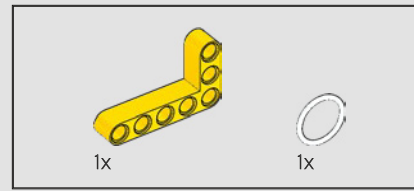
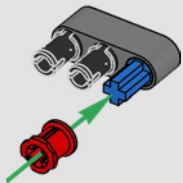

52

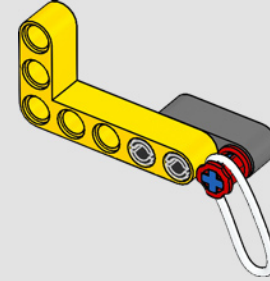

53

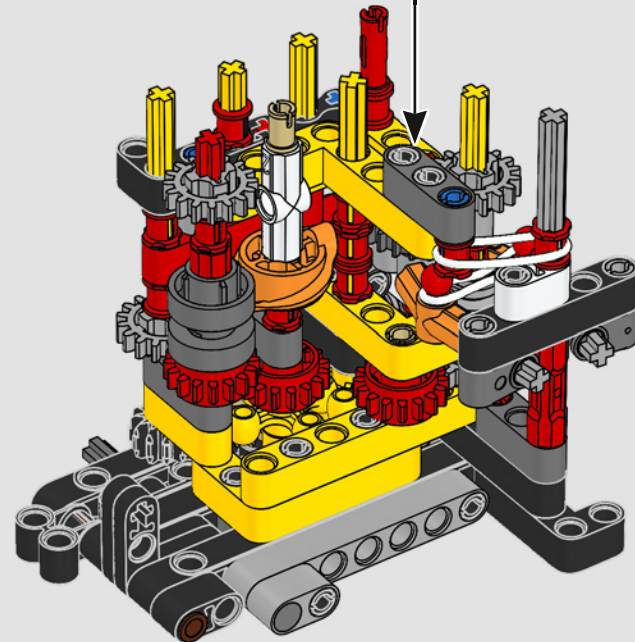

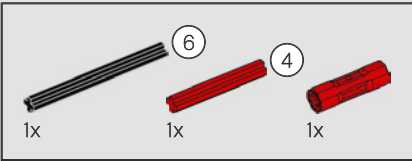
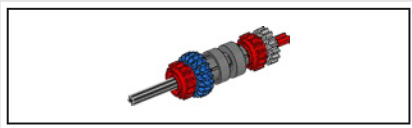

54

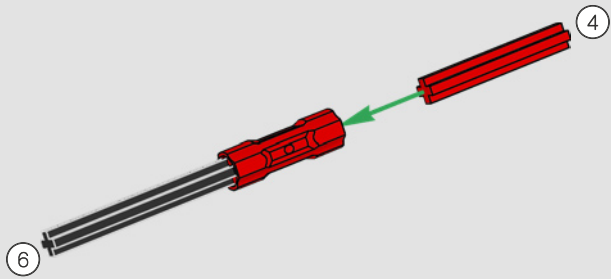

55

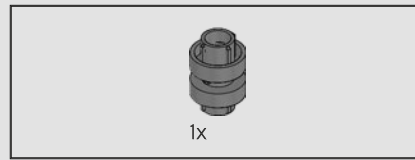
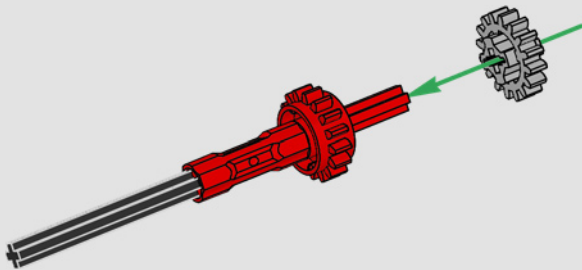

56

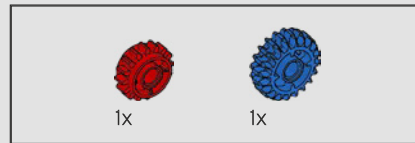
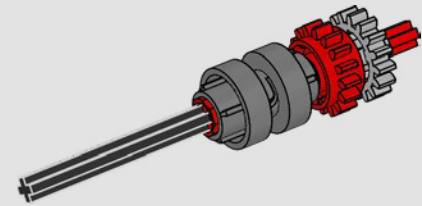

57

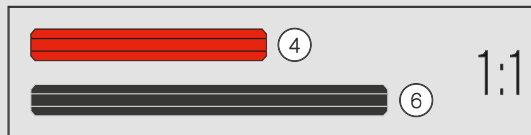
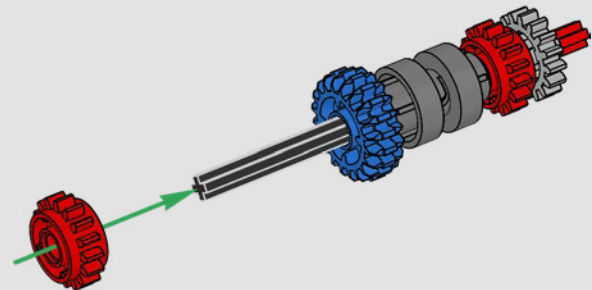

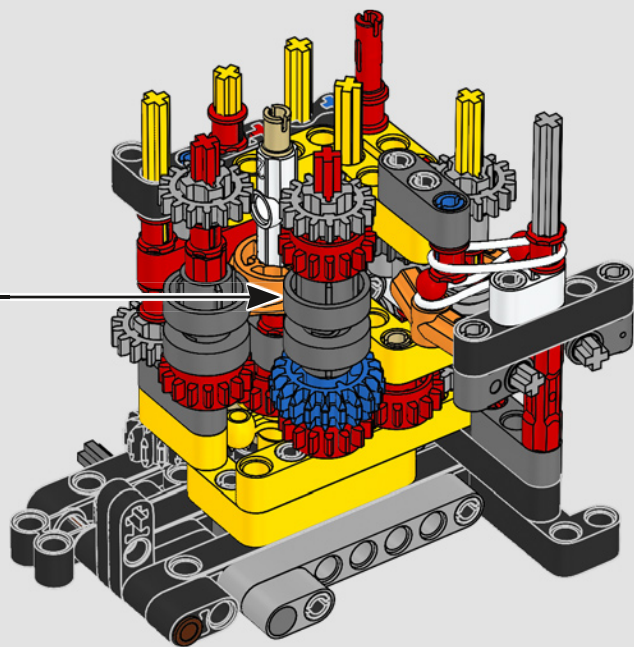

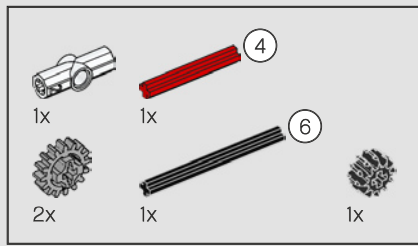

59

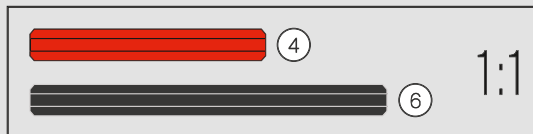
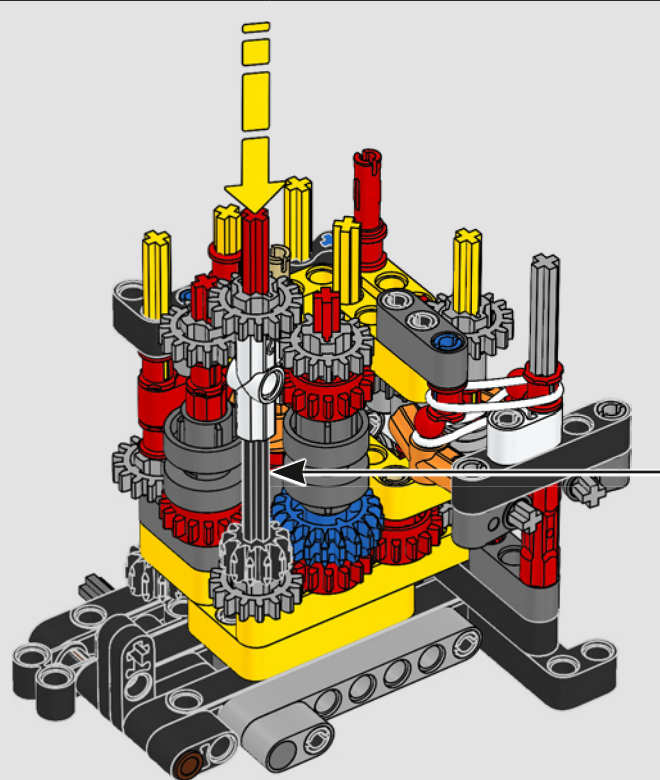
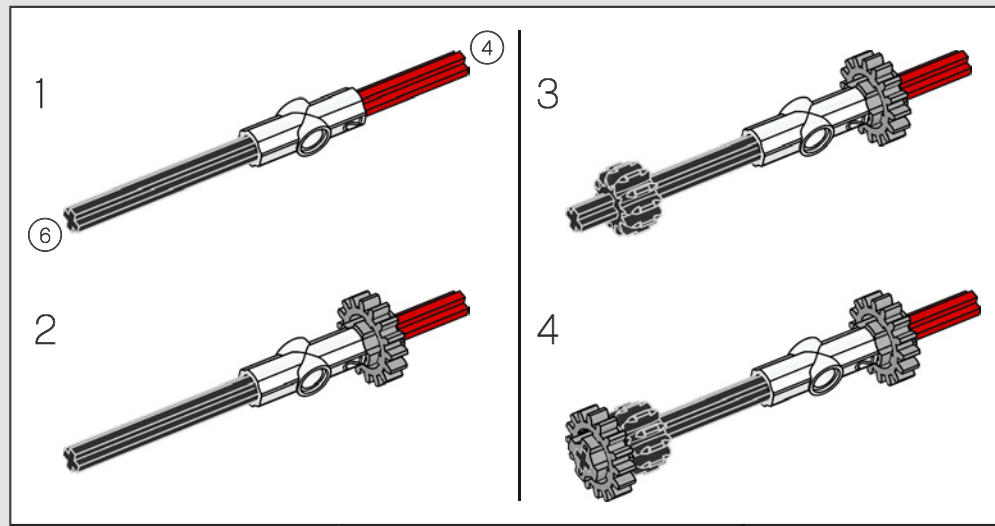

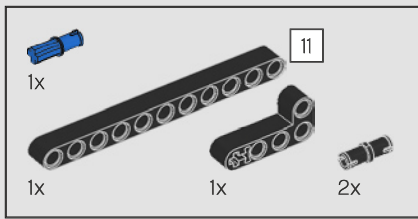

60

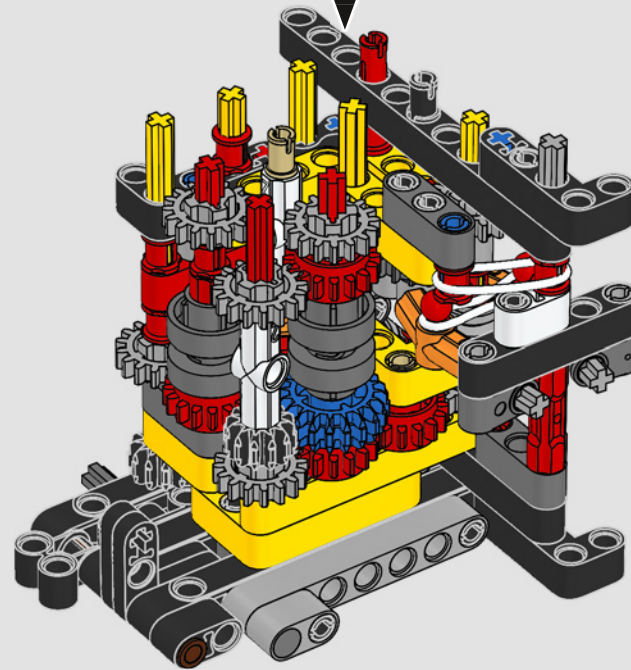
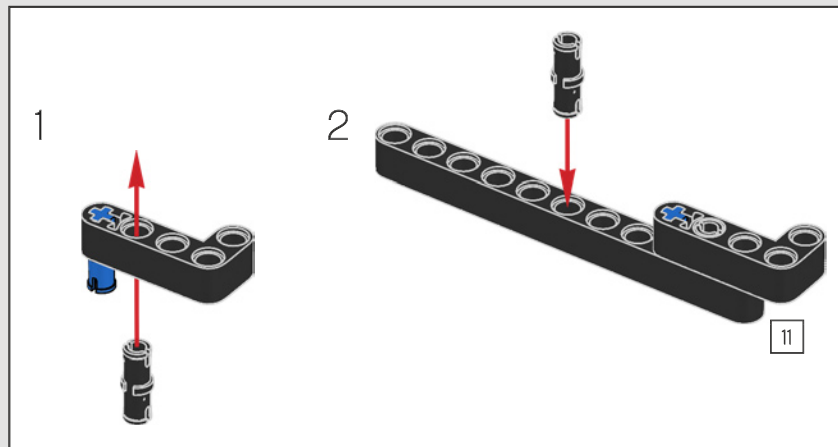

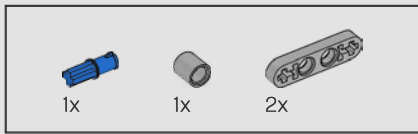

61

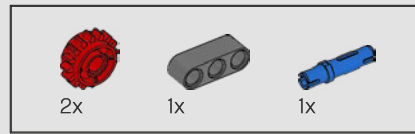
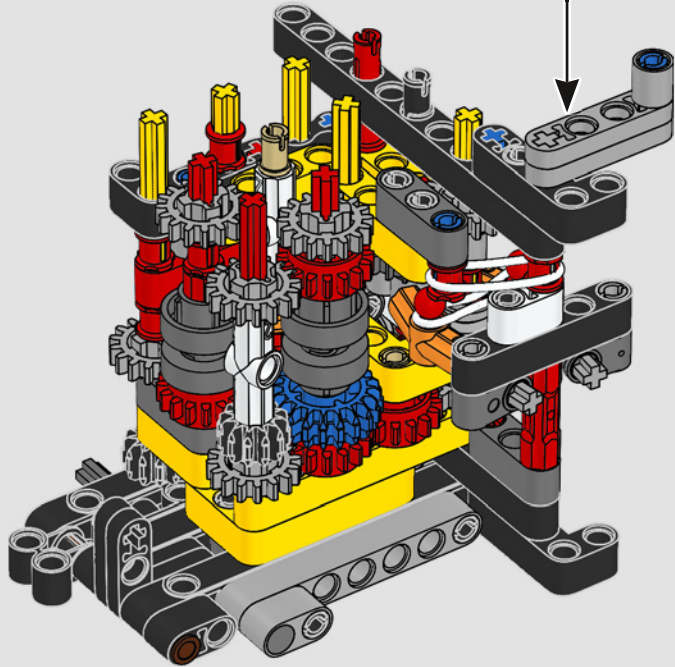
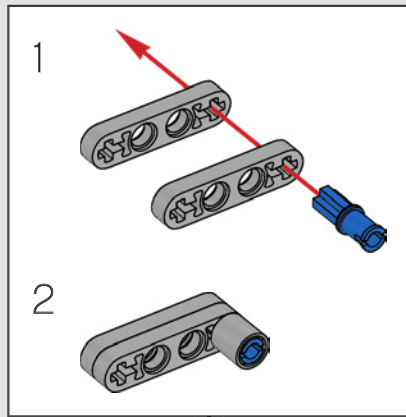

62

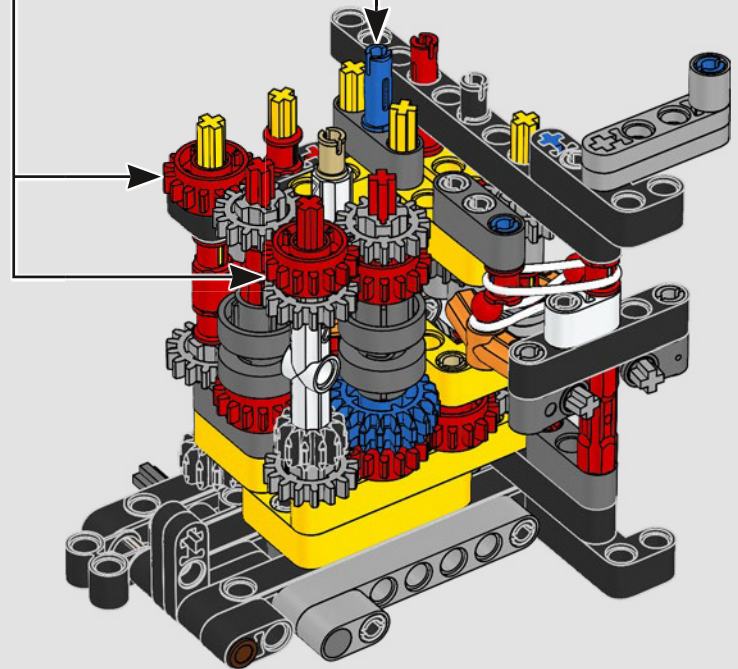
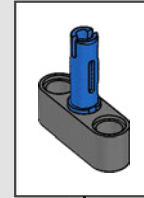
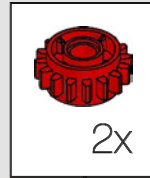

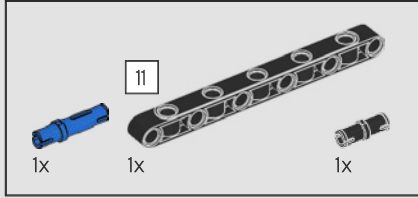
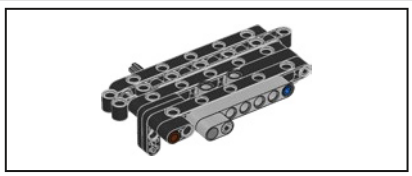

63

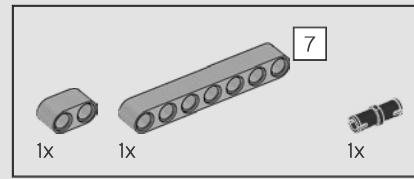
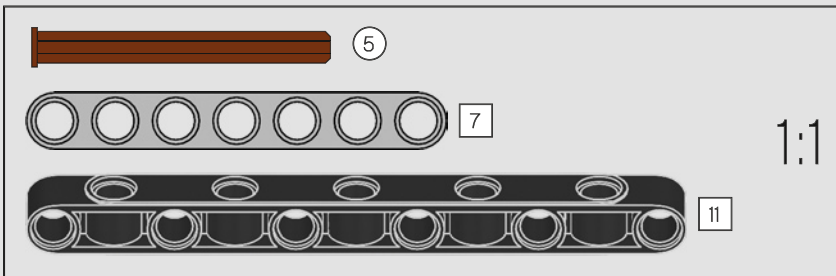
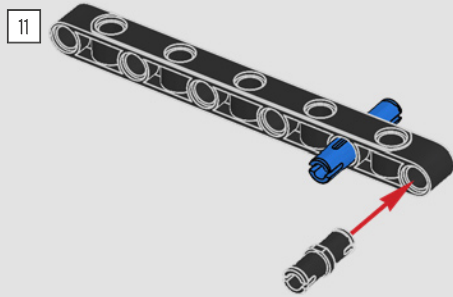

64

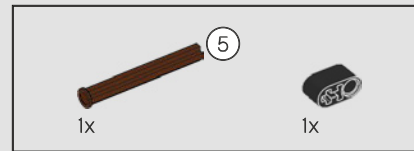
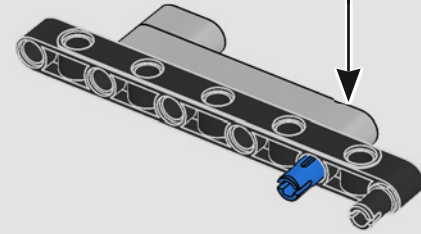
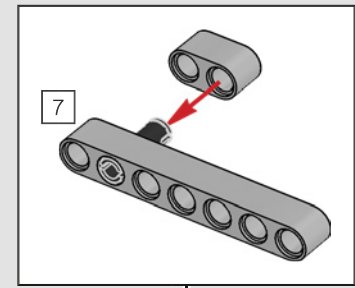

65

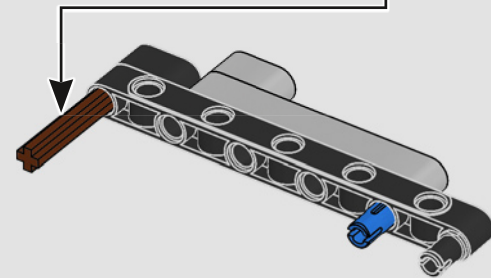
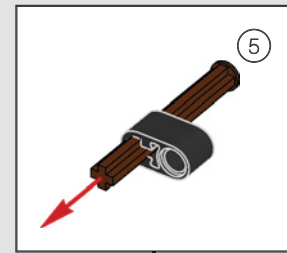



66

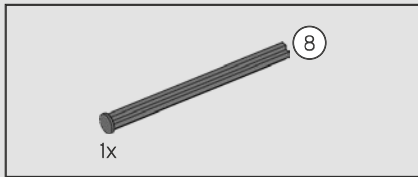
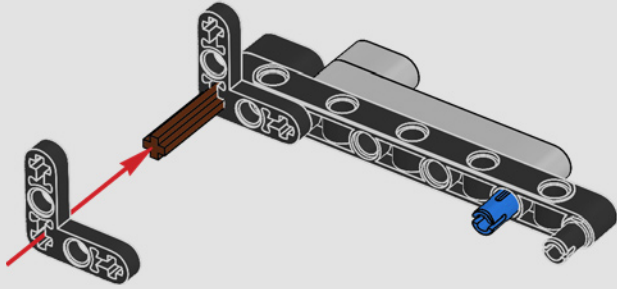

67

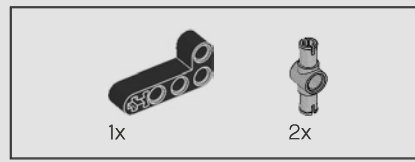
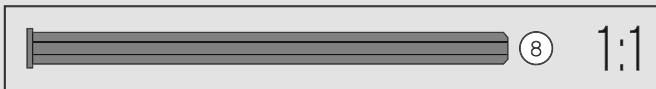
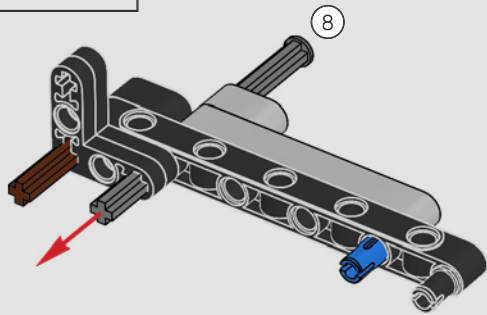

68

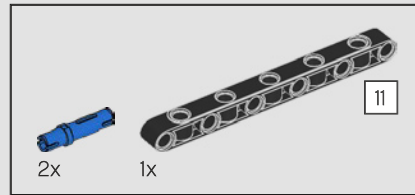
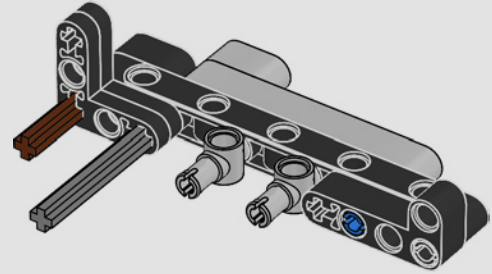

69

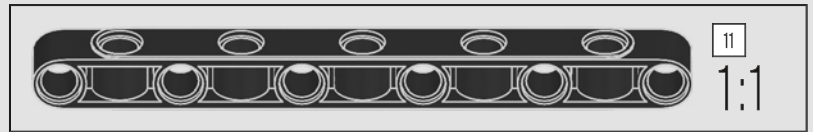
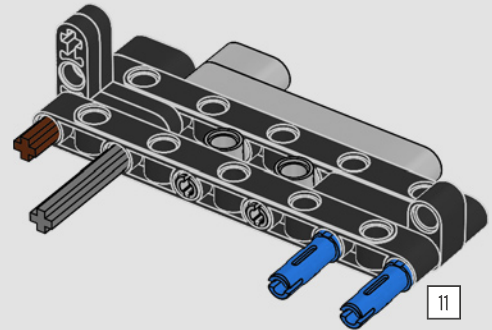

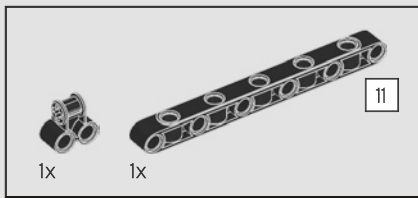

70

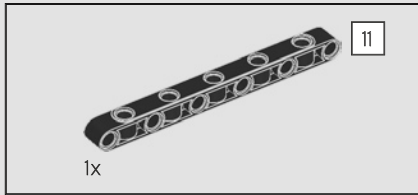
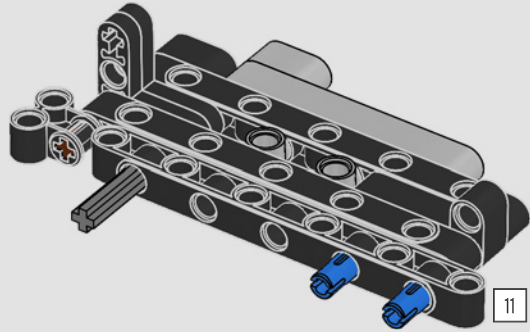

71

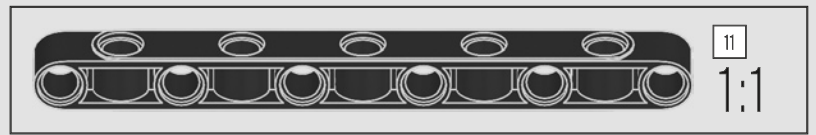
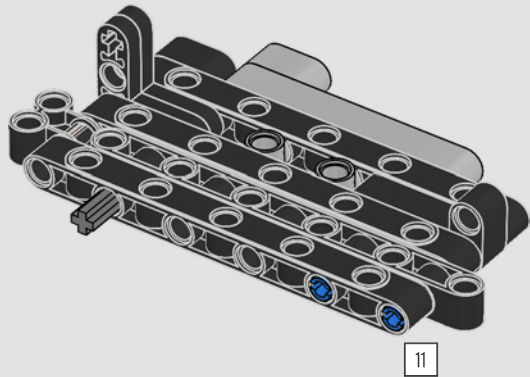

72

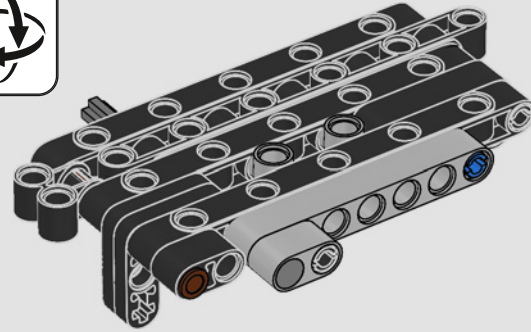

73

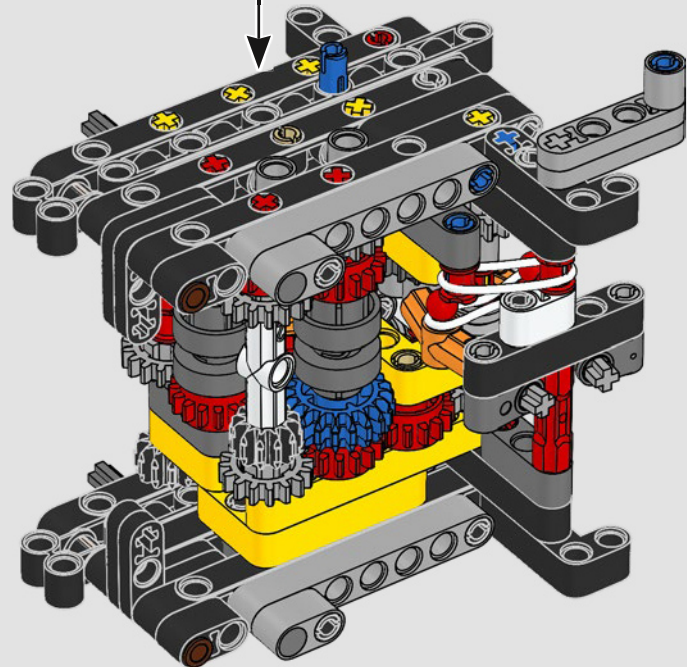

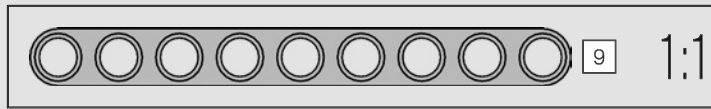
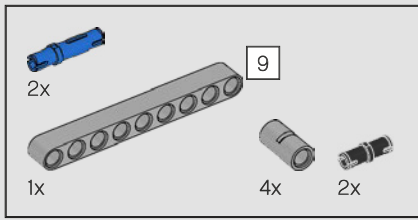

74

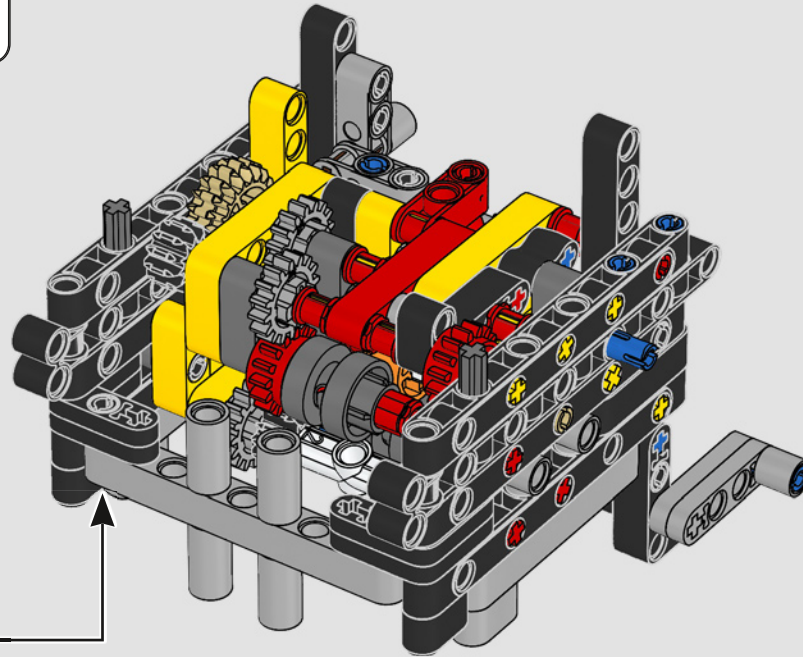
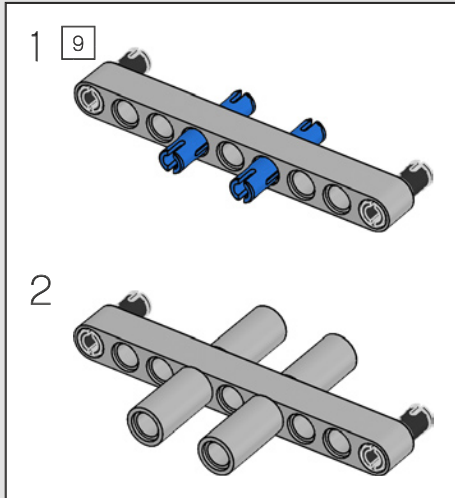

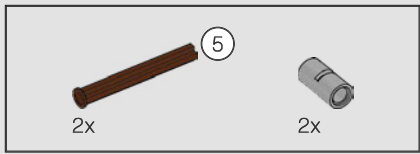

75

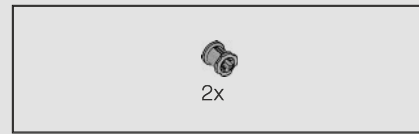
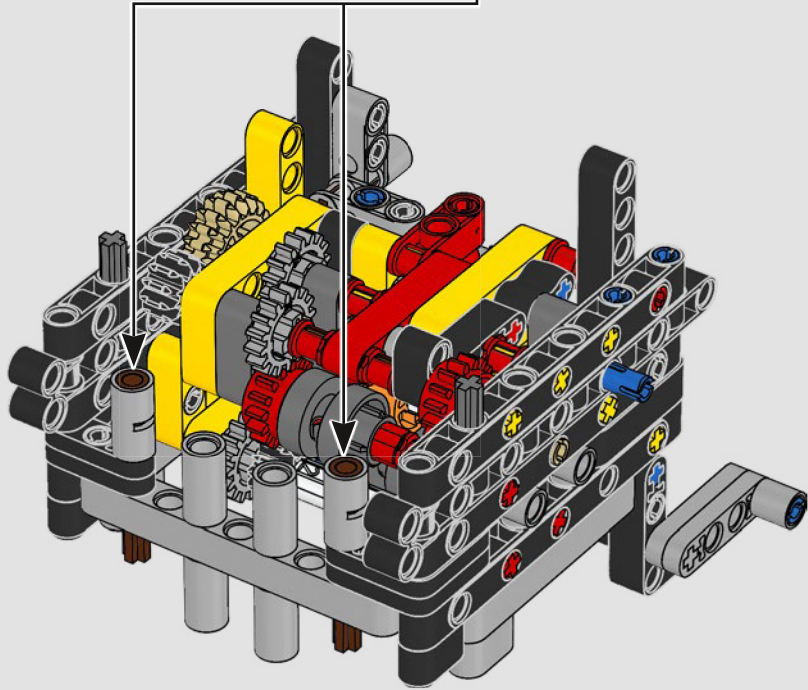
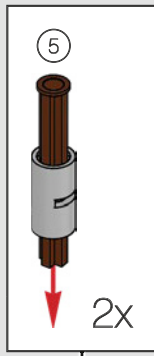

76

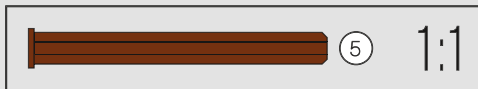
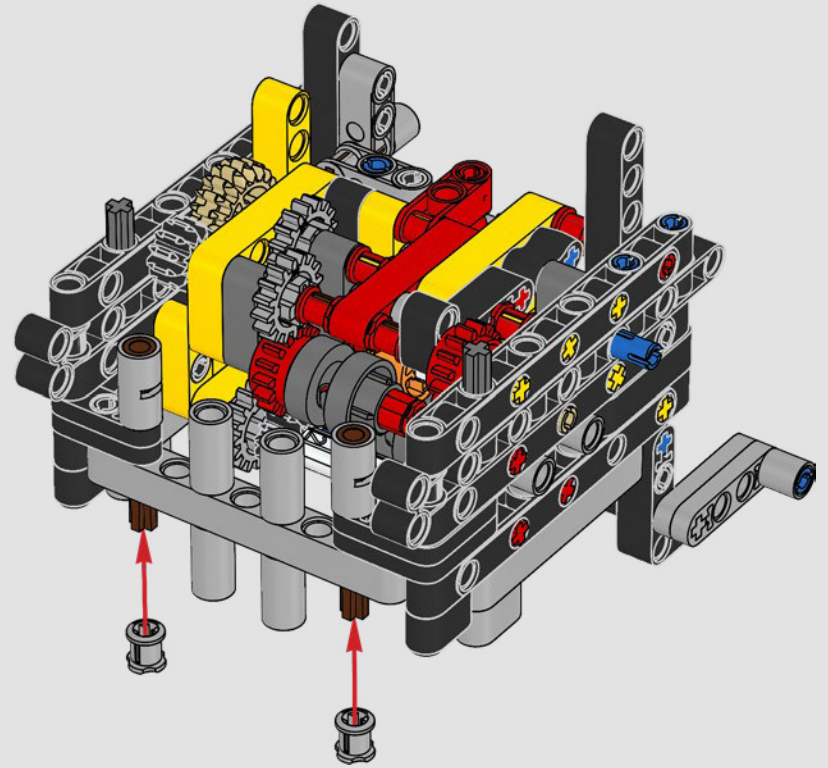

62x

77

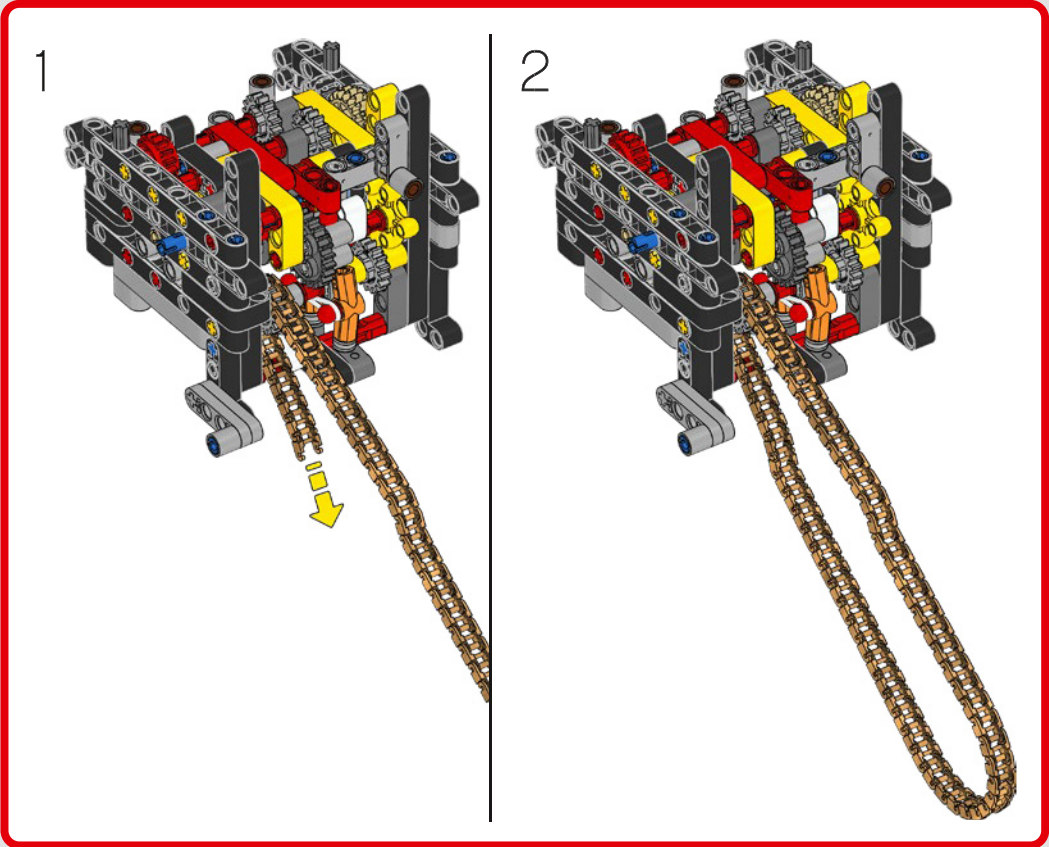
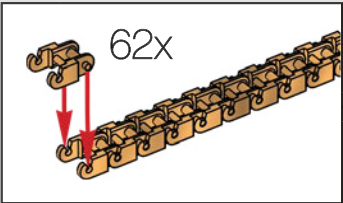
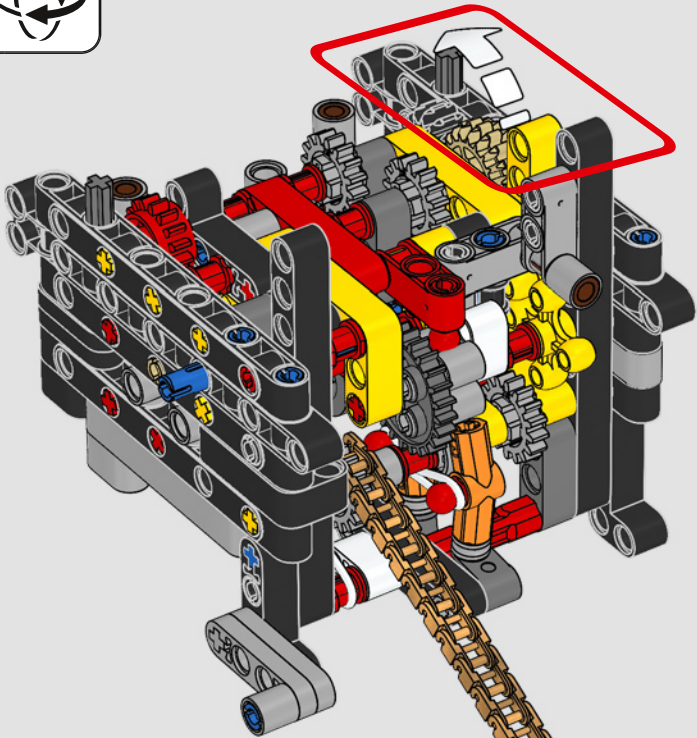

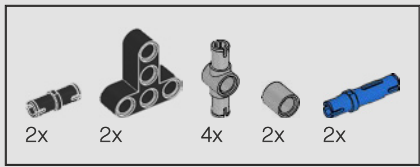

78

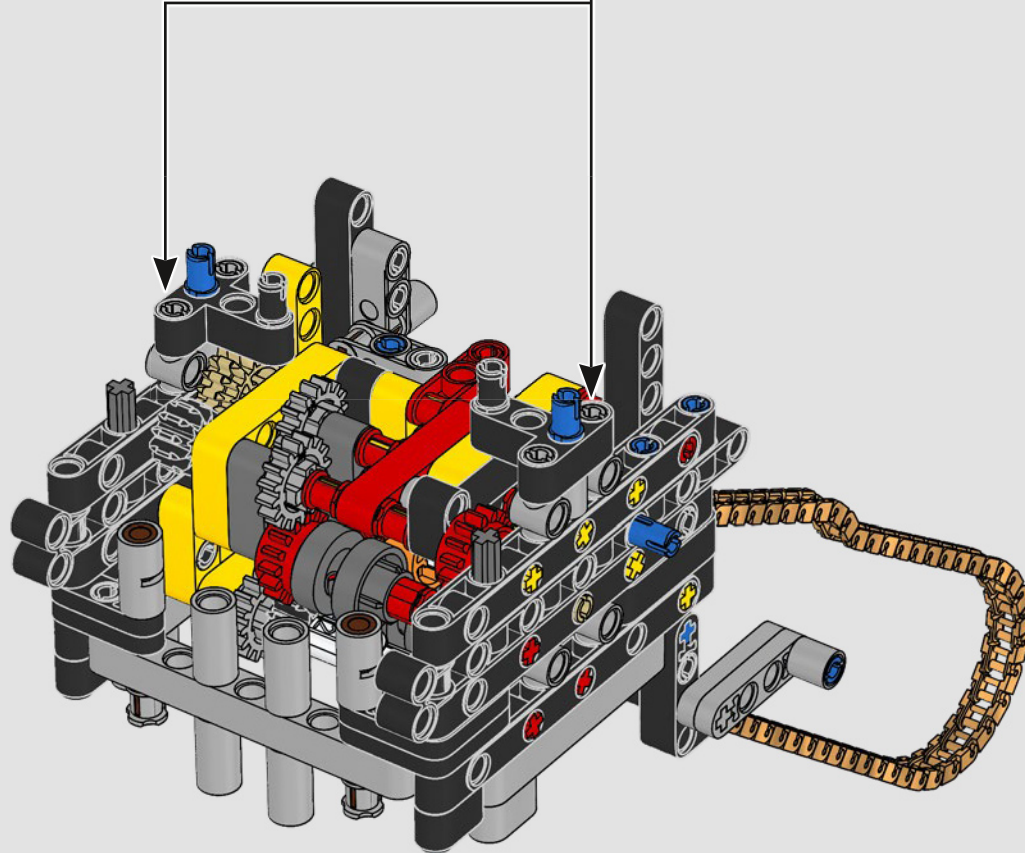
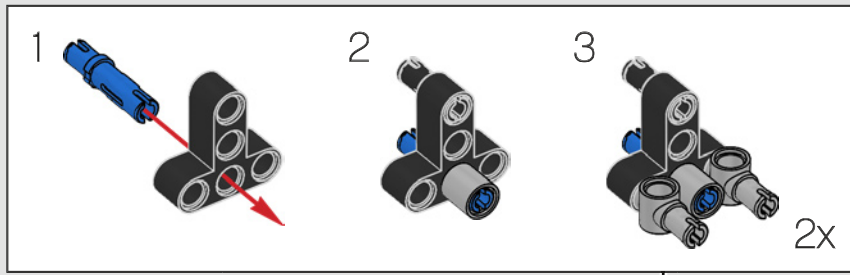

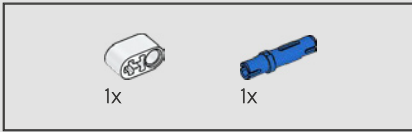
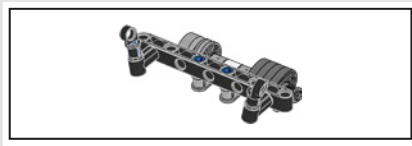

79

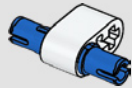

80

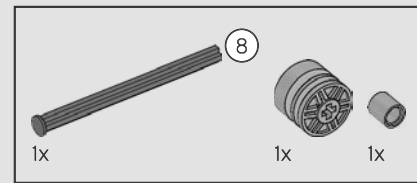
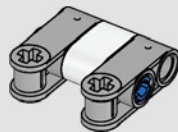

81

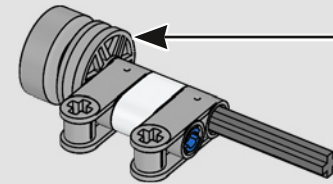
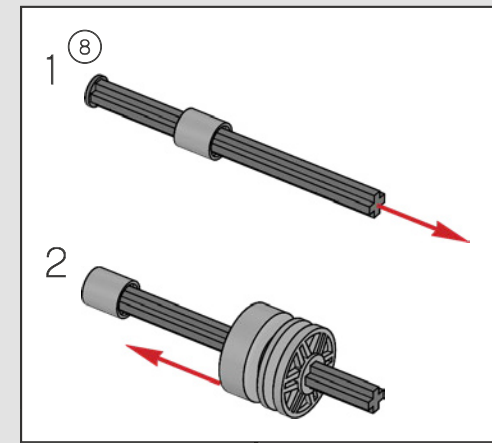

82

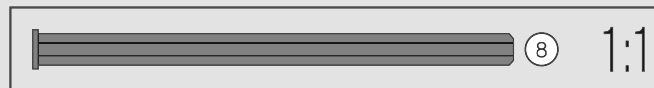
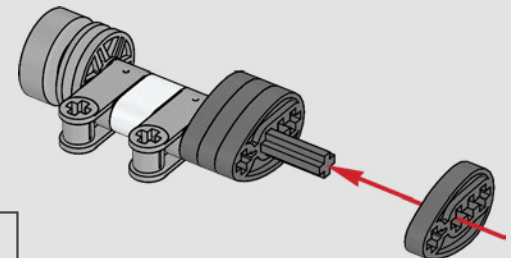

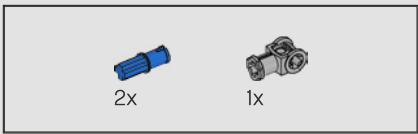

83

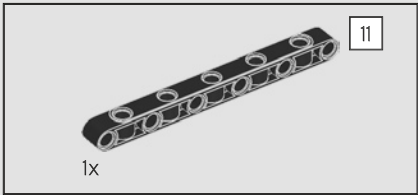
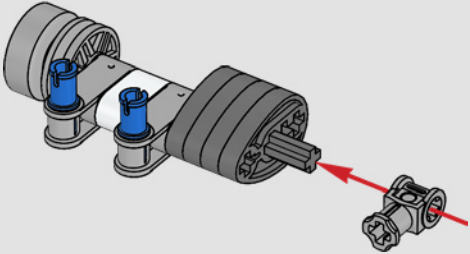

84

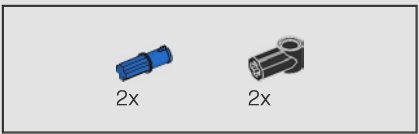
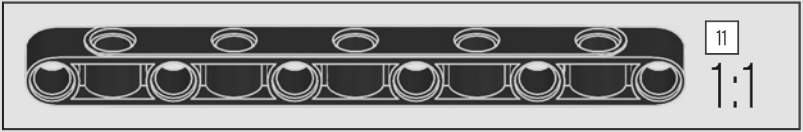
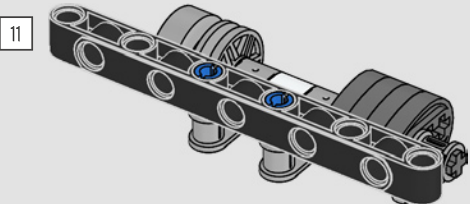

85

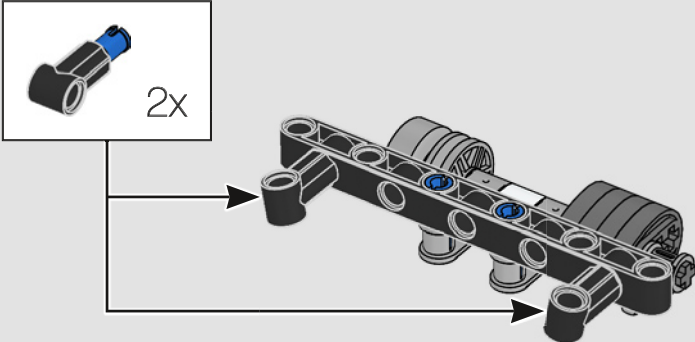

86

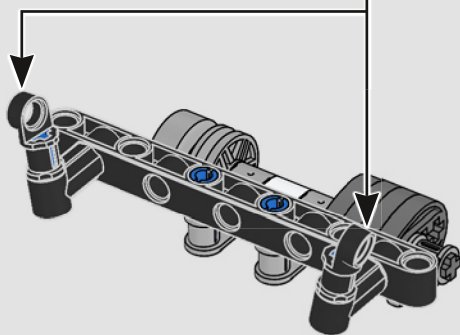
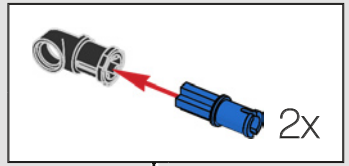

87

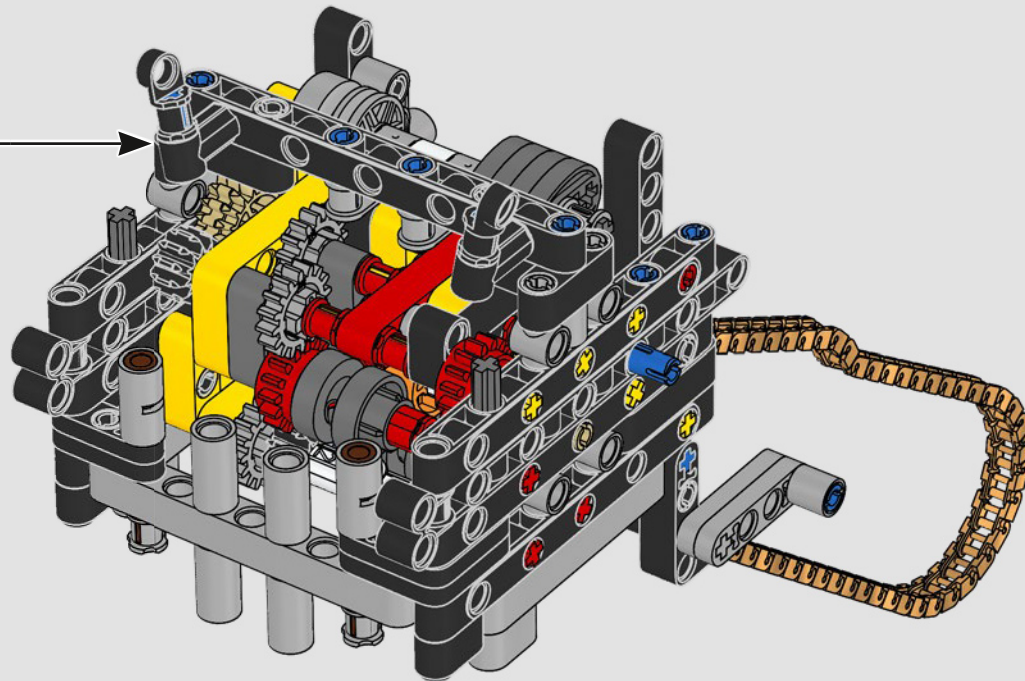

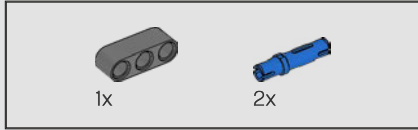
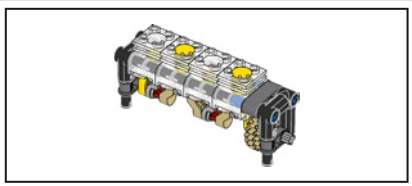

88

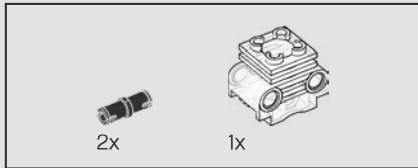
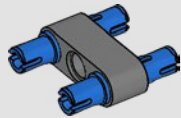

89

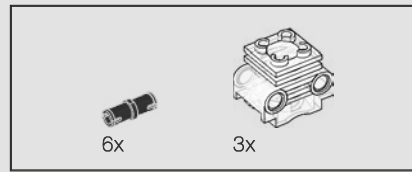
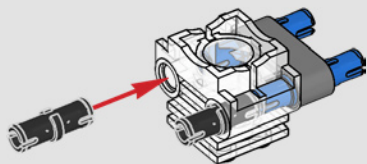

90

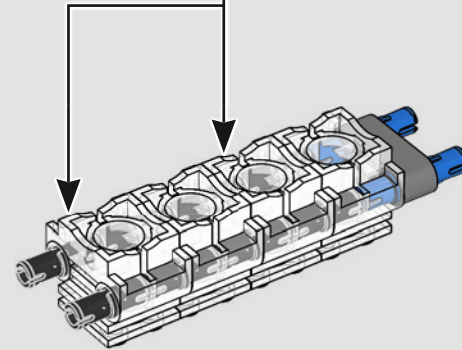
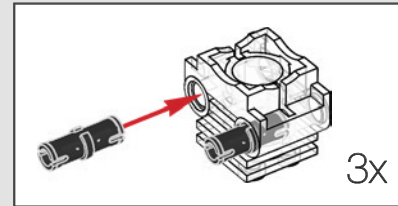

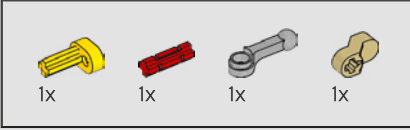
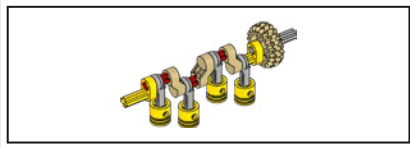

91

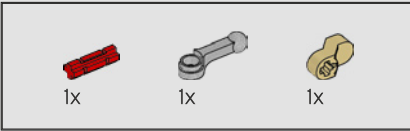
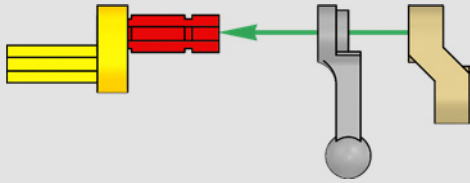

92

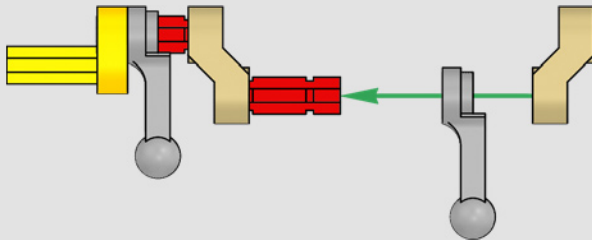

93

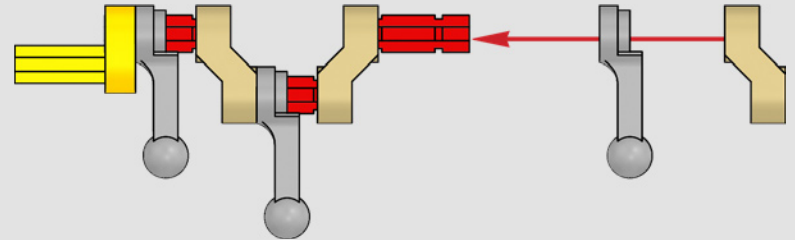

94

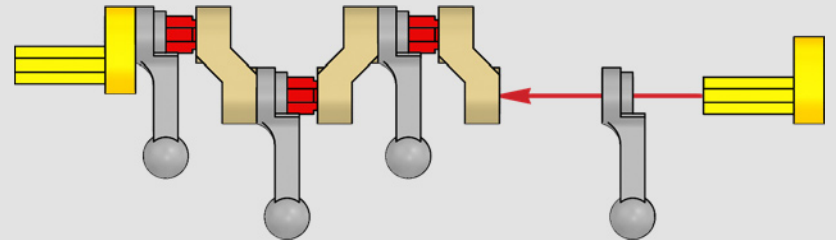



4x

95

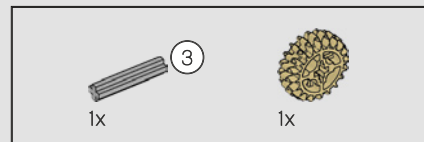
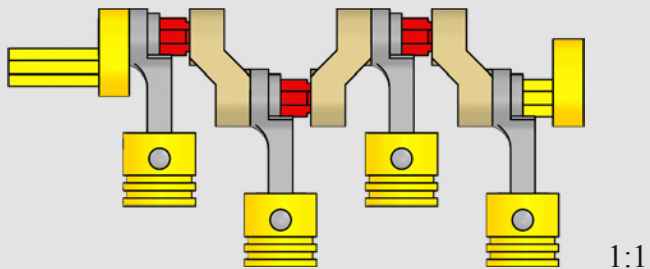

96

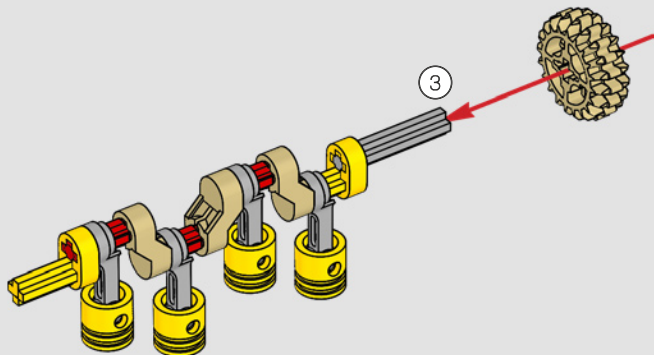
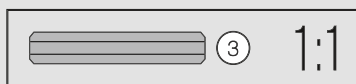

97

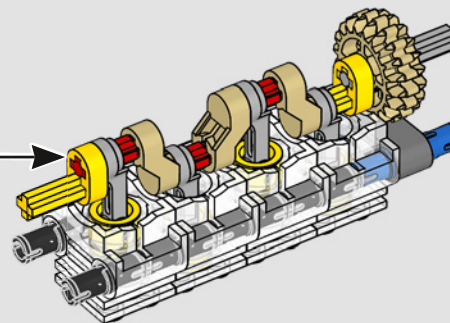

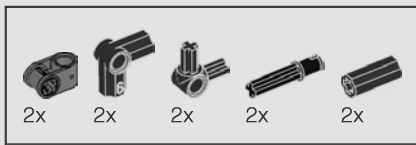

98

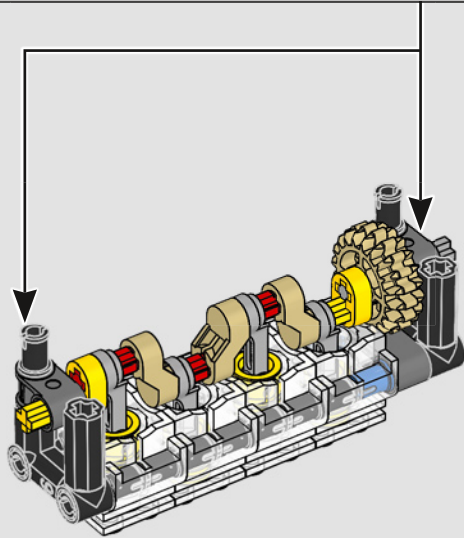
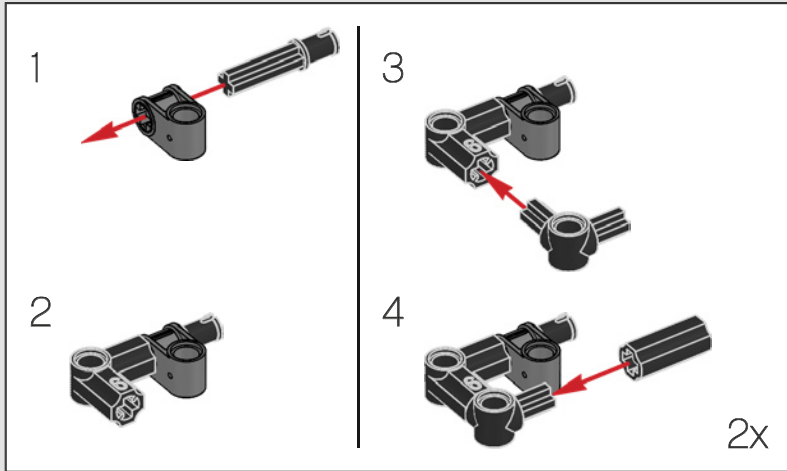

99

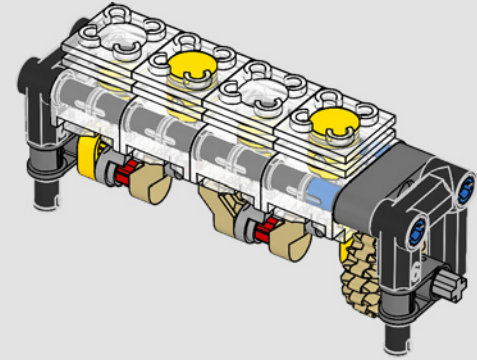
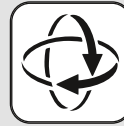

100

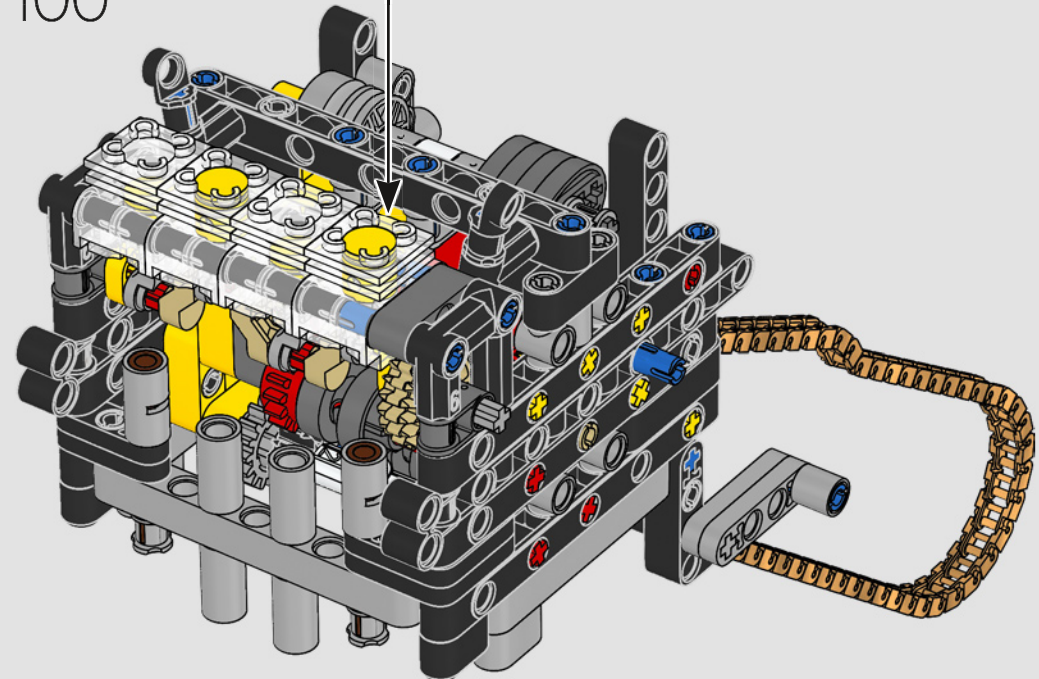

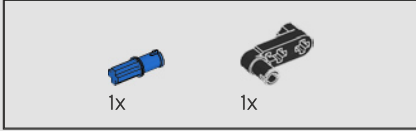
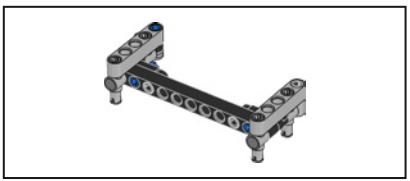

101

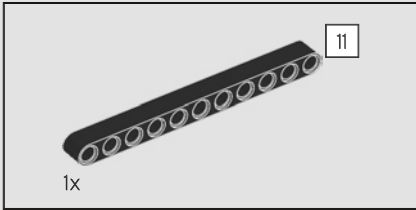

102

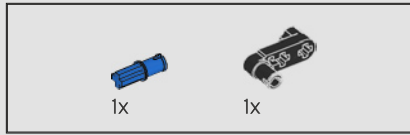
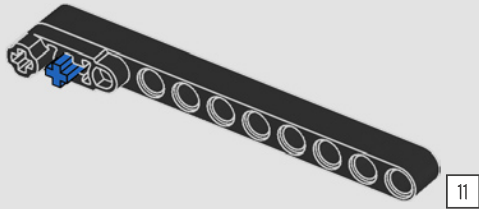

103

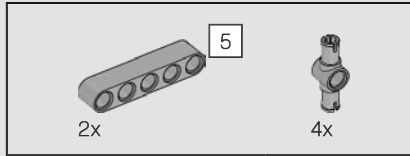
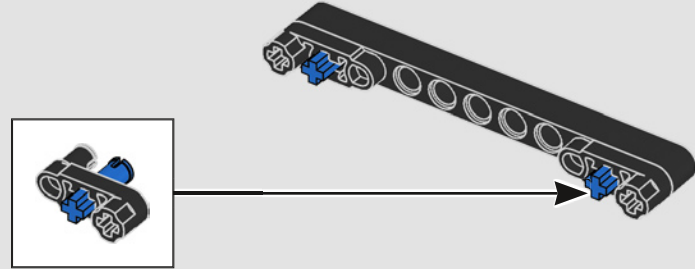

104

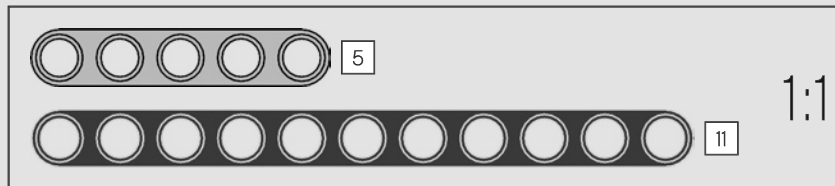
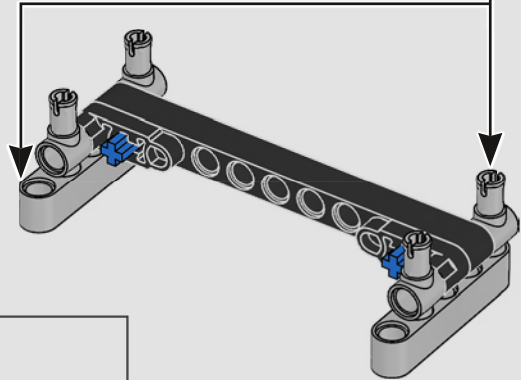
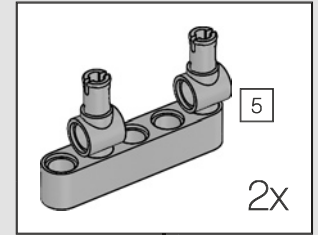

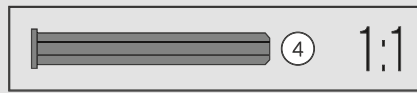
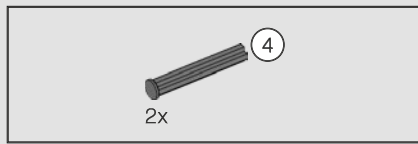

105

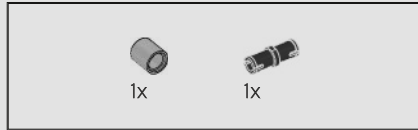
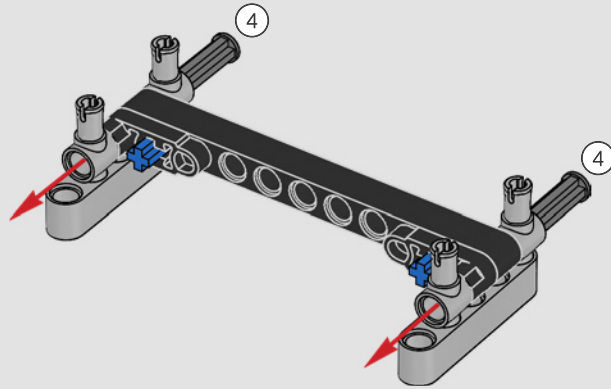

106

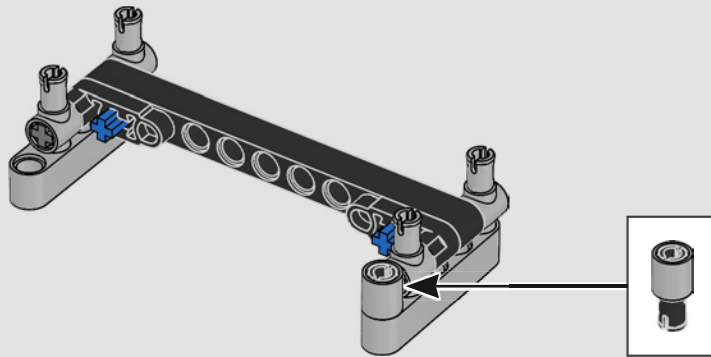

107

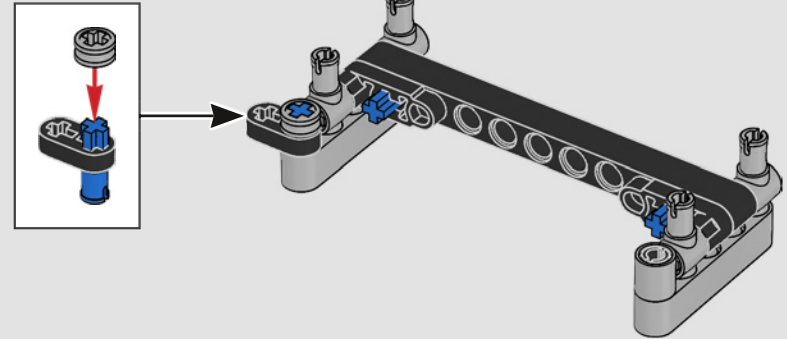

108

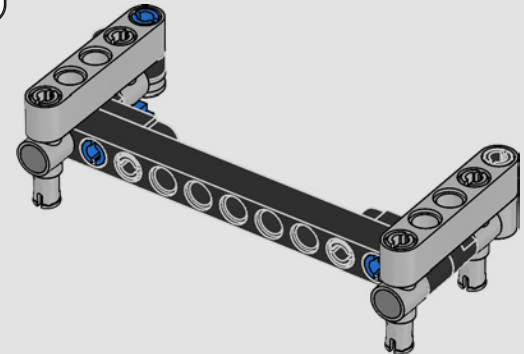

109

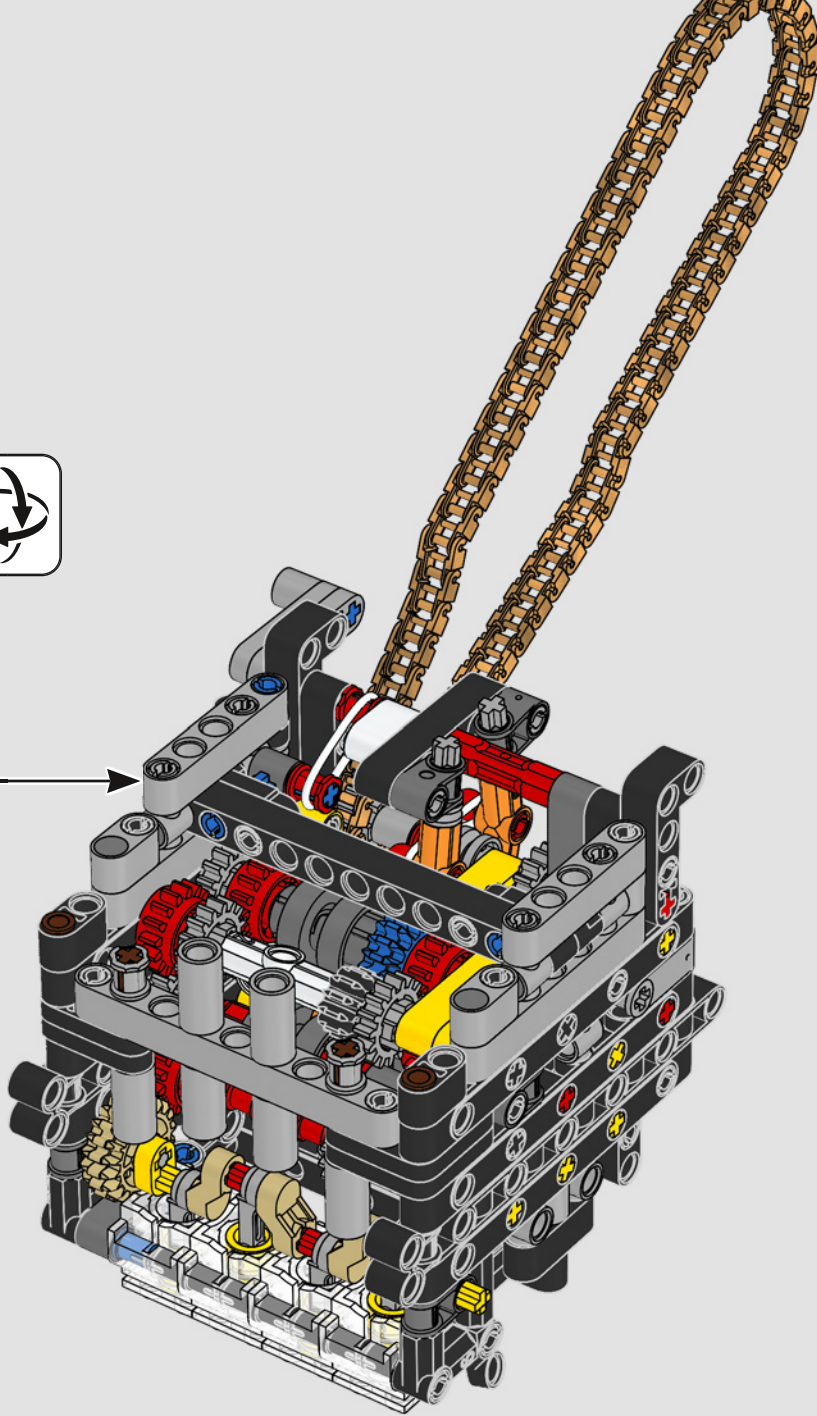

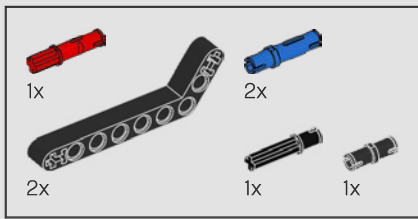

110

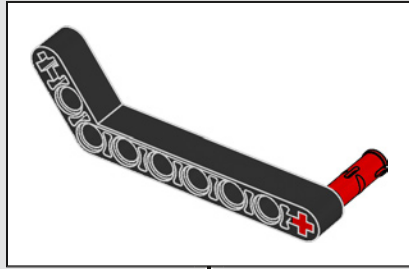

1

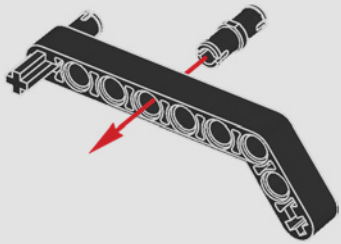

2

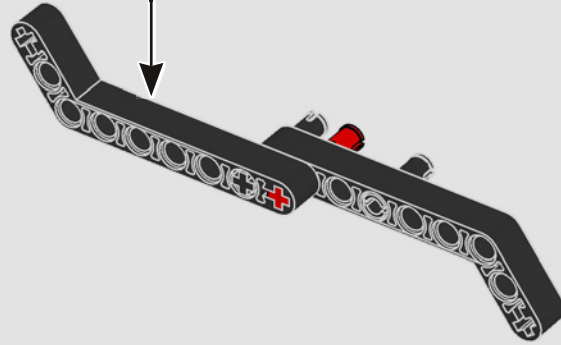

3

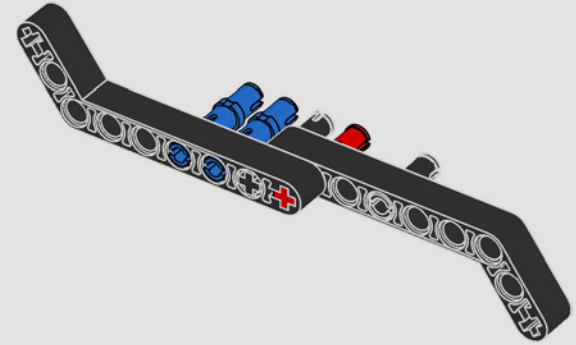

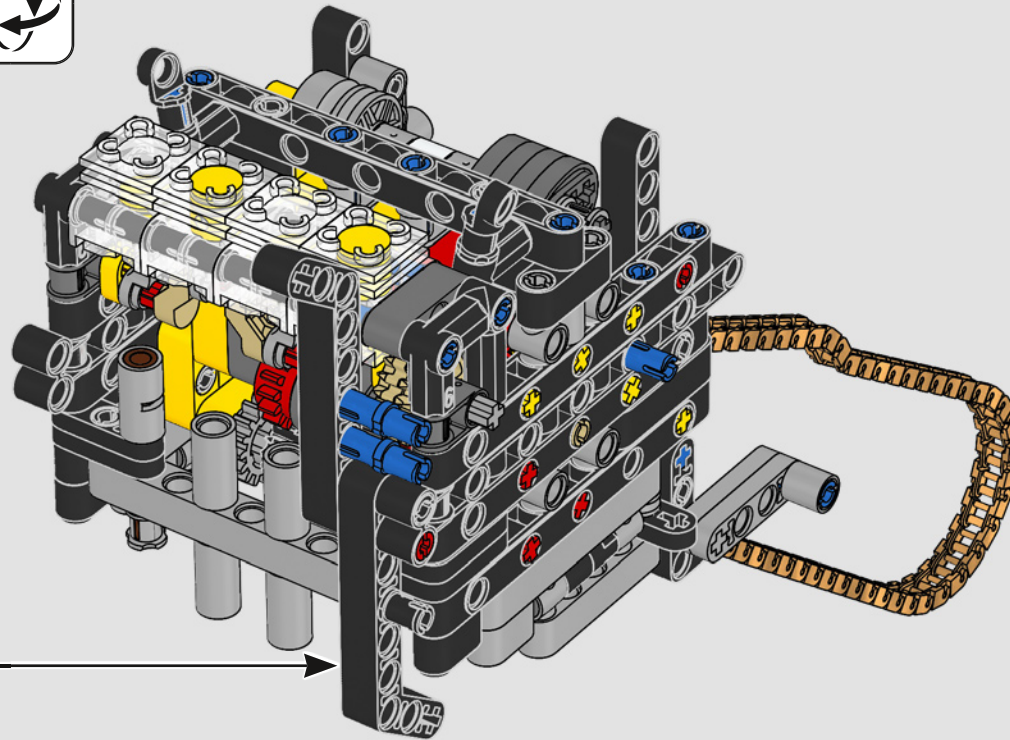

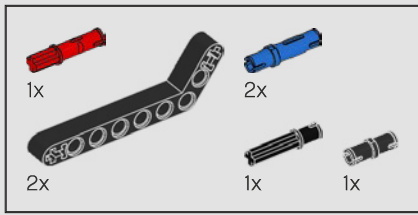

111

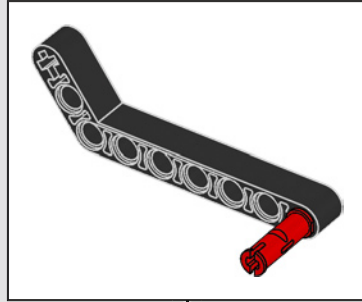

1

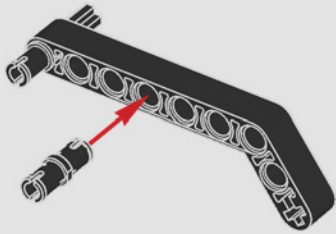

2

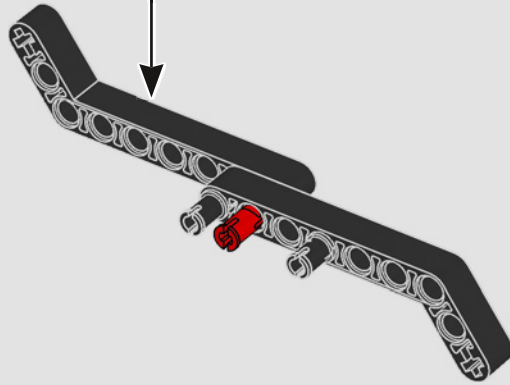

3

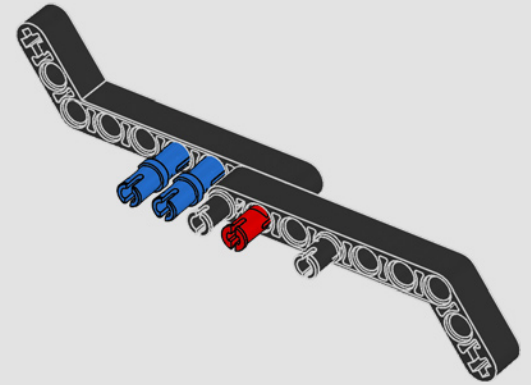

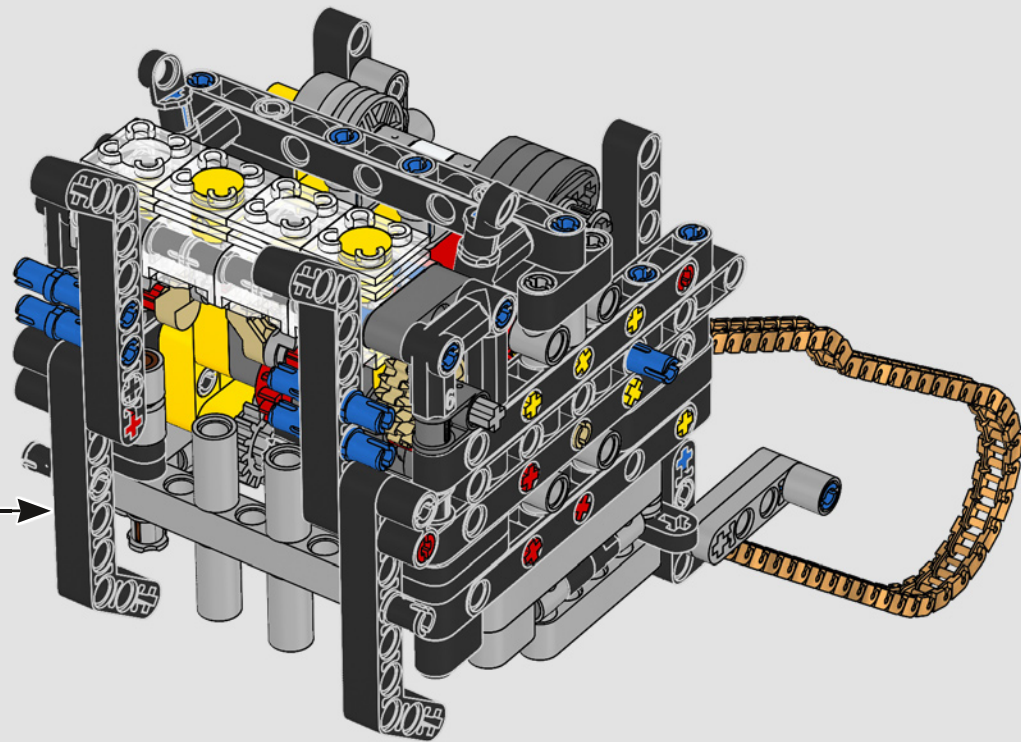

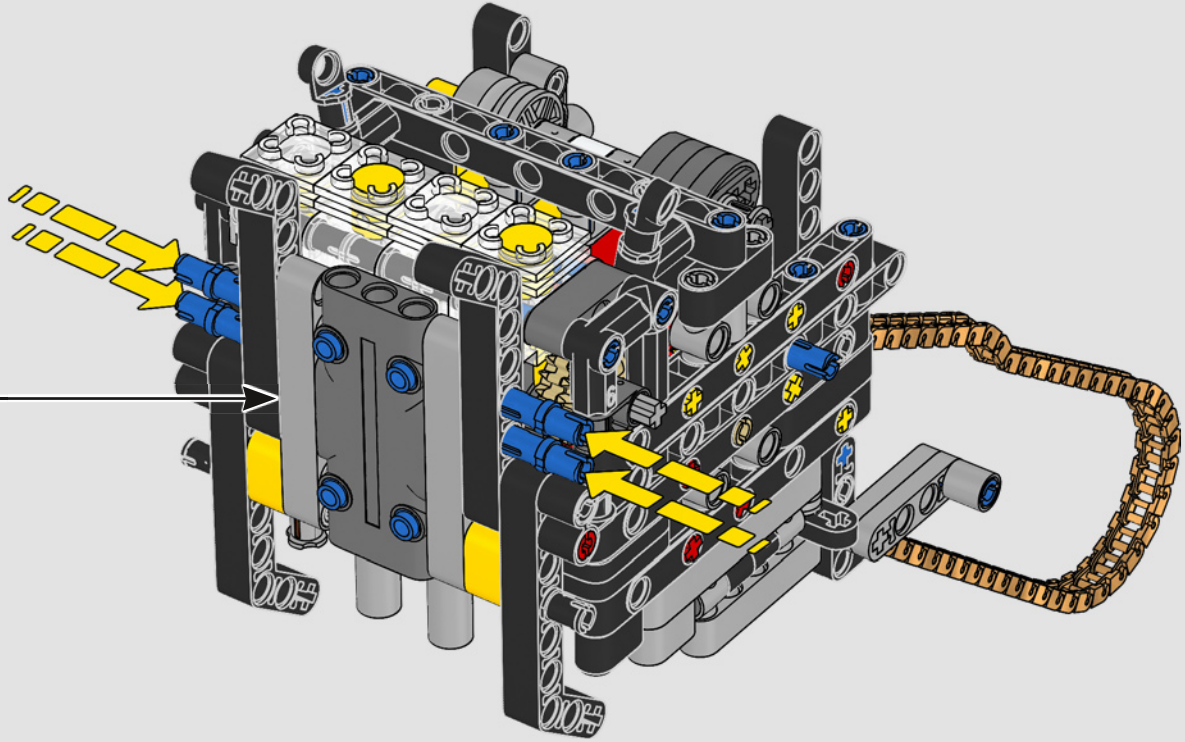

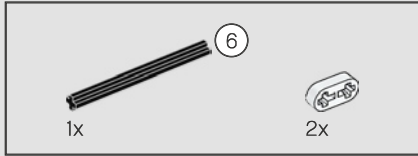
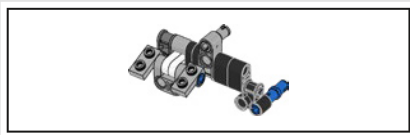

116

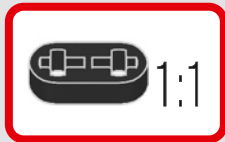
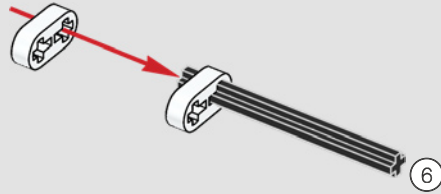

117

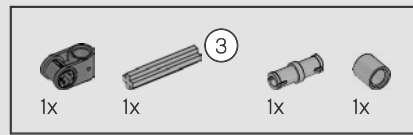
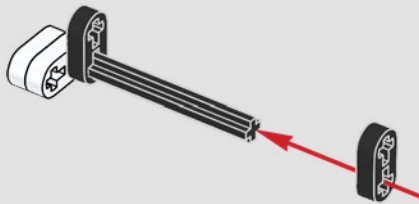

118

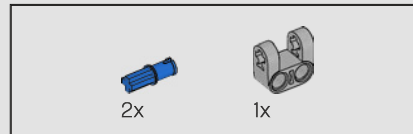
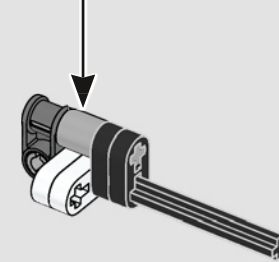
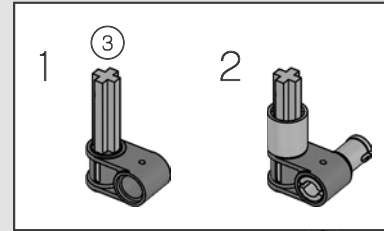

119

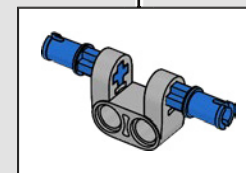
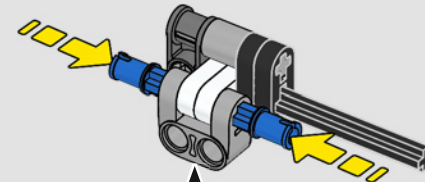



2x

120

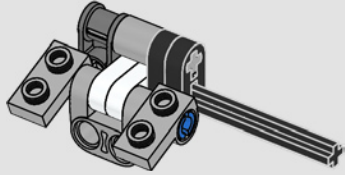

1x



1x

121

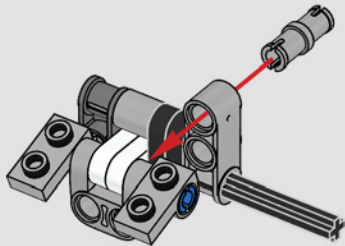

2x

122

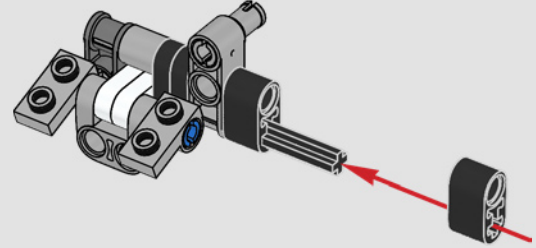

1:1



1x



1x

123

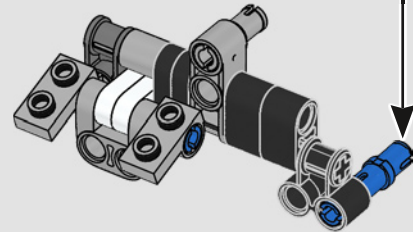
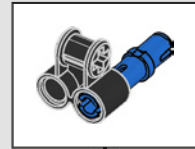

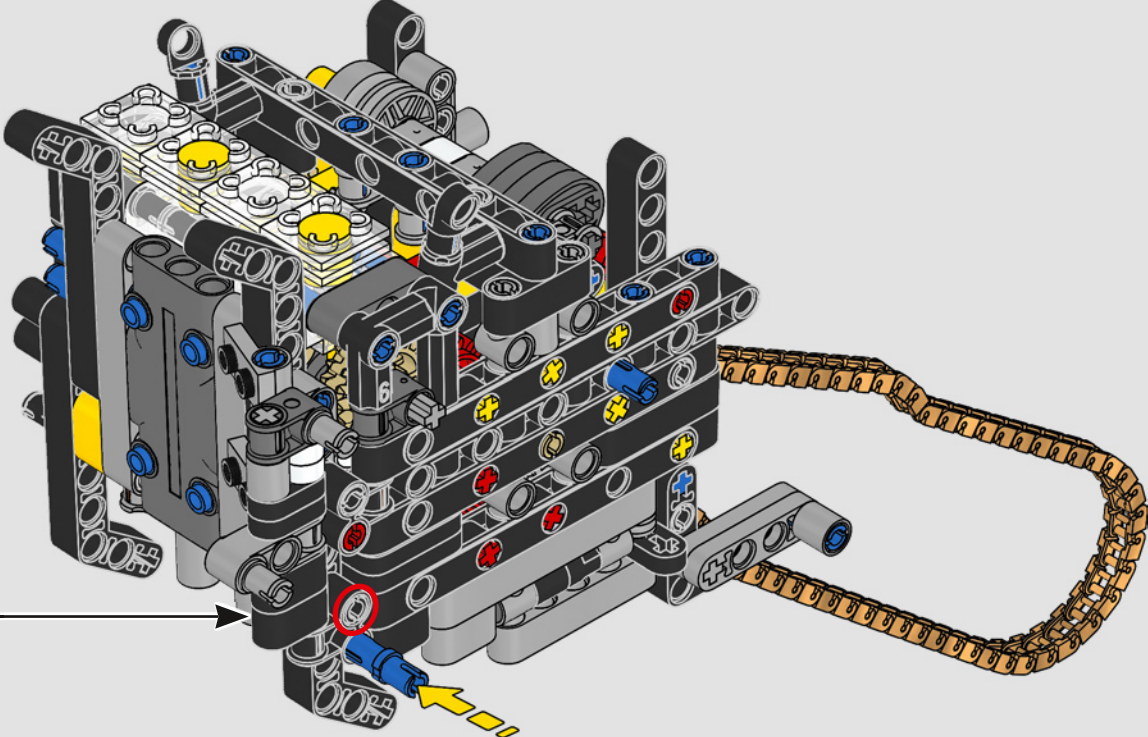

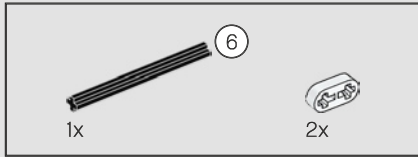
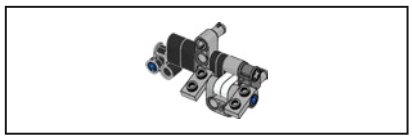

125

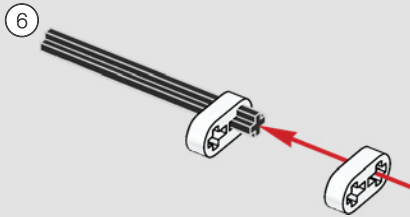

126

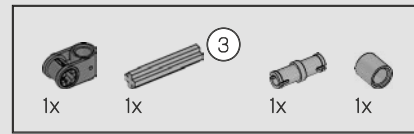
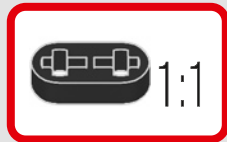
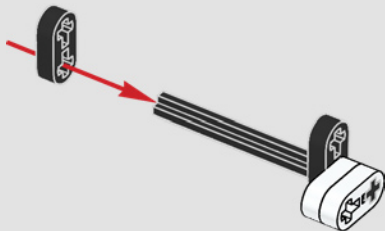

127

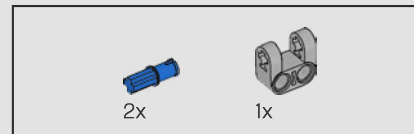
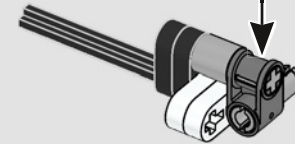
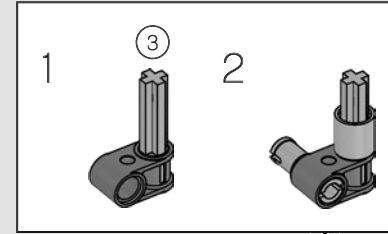

128

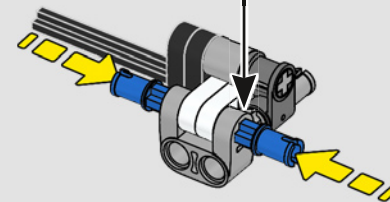
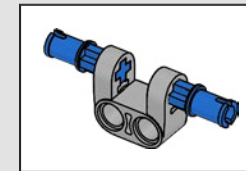

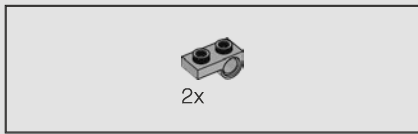

129

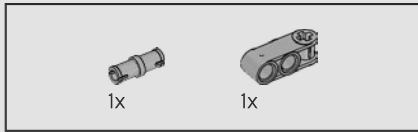
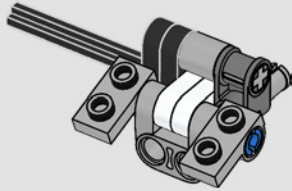

130

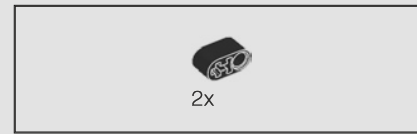
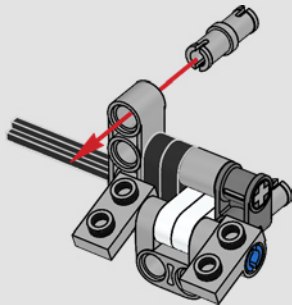

131

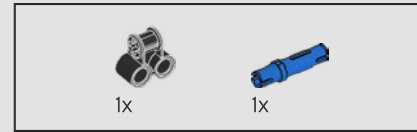
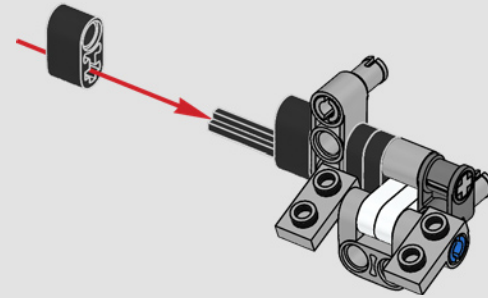

132

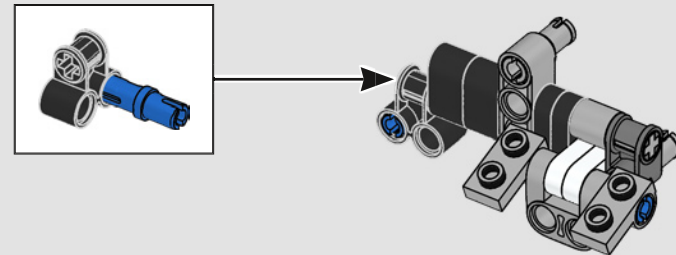

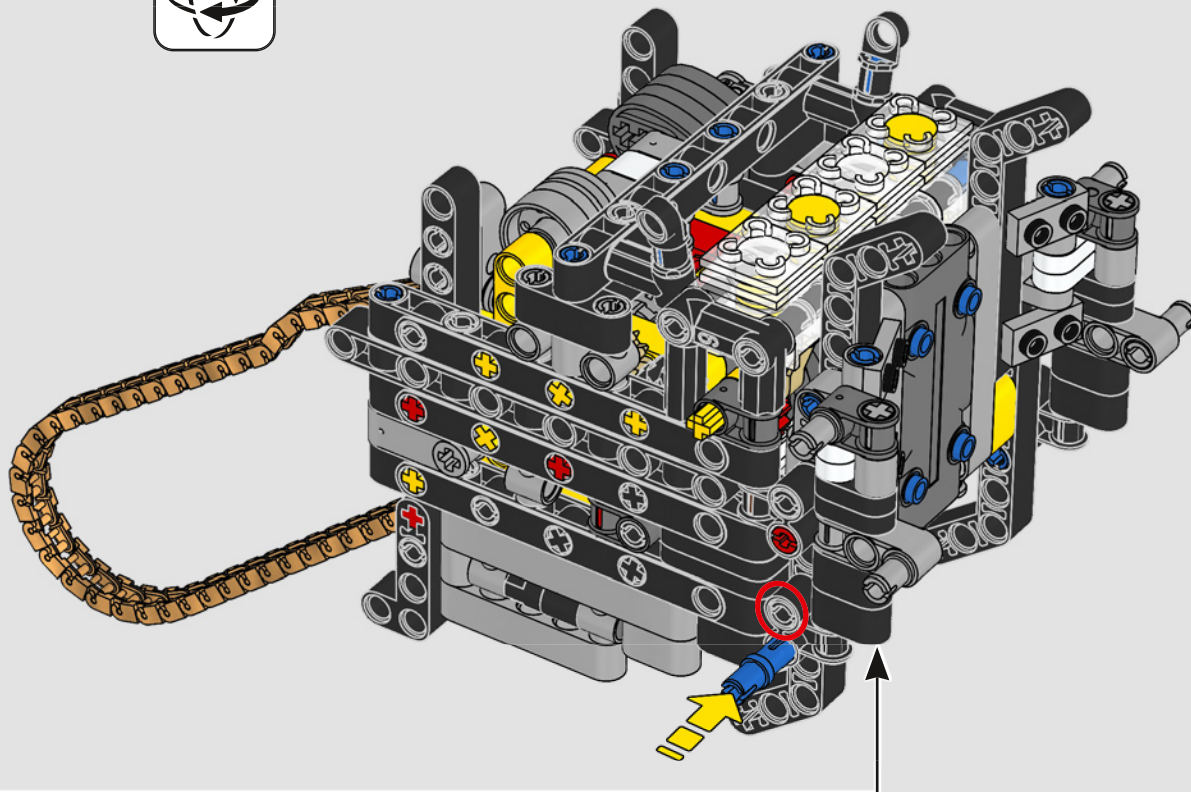

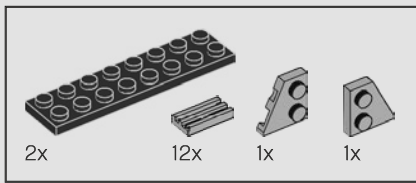

134

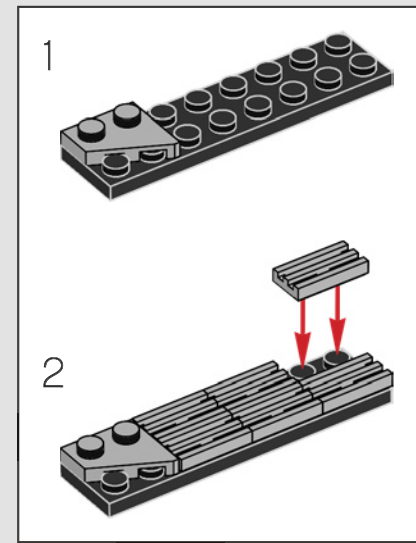
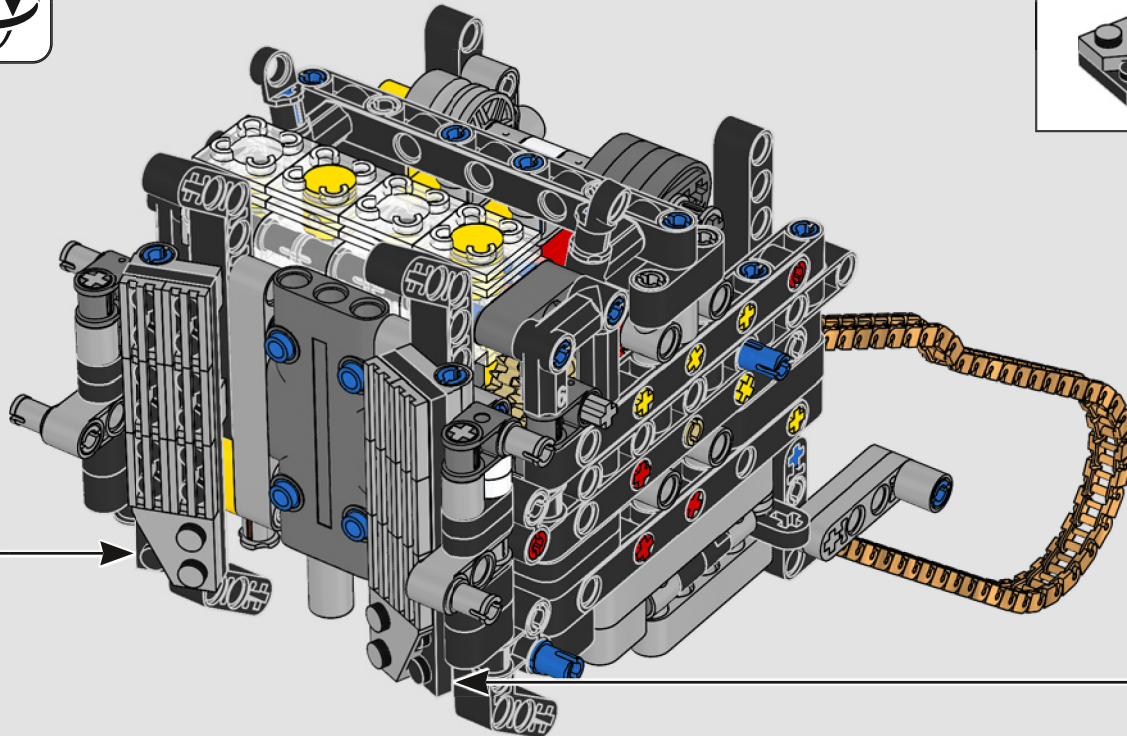
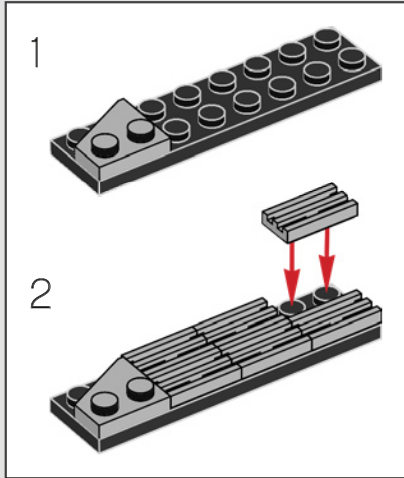

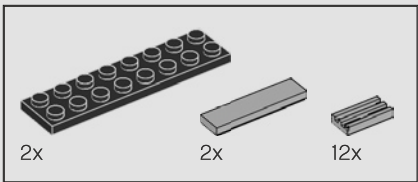

135

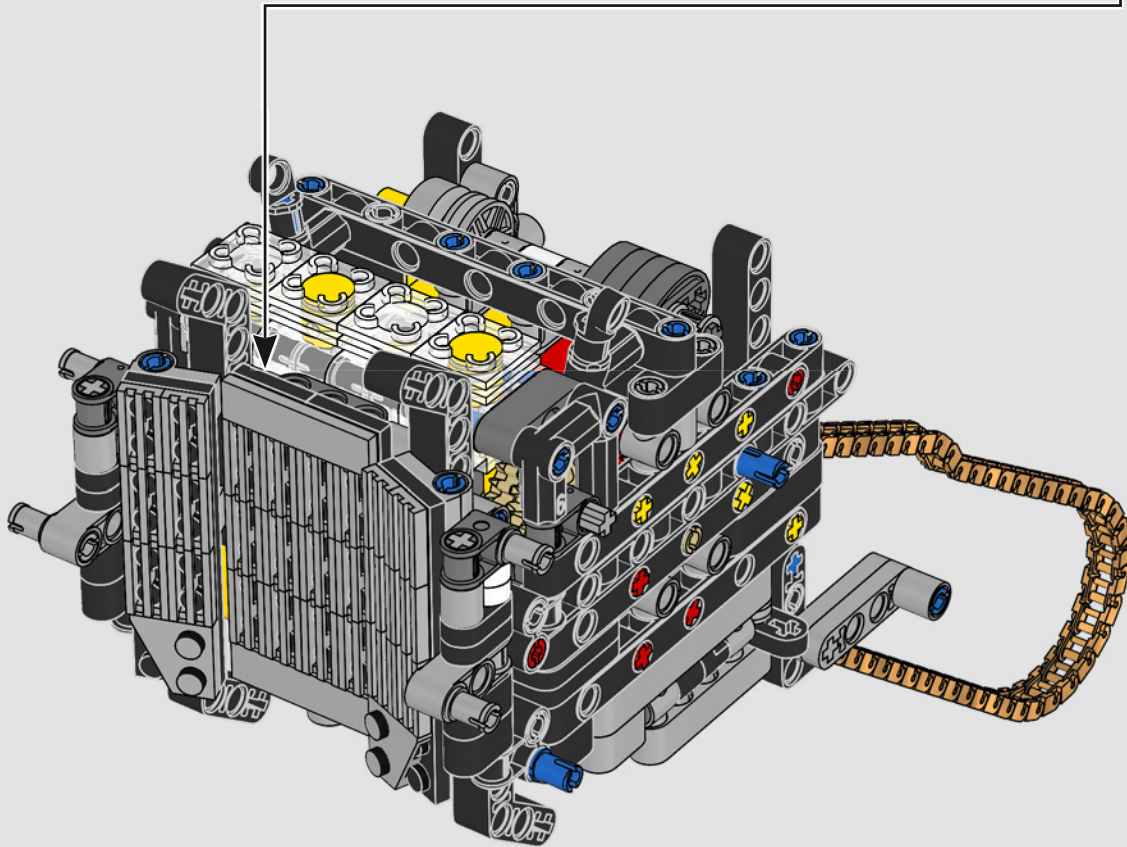
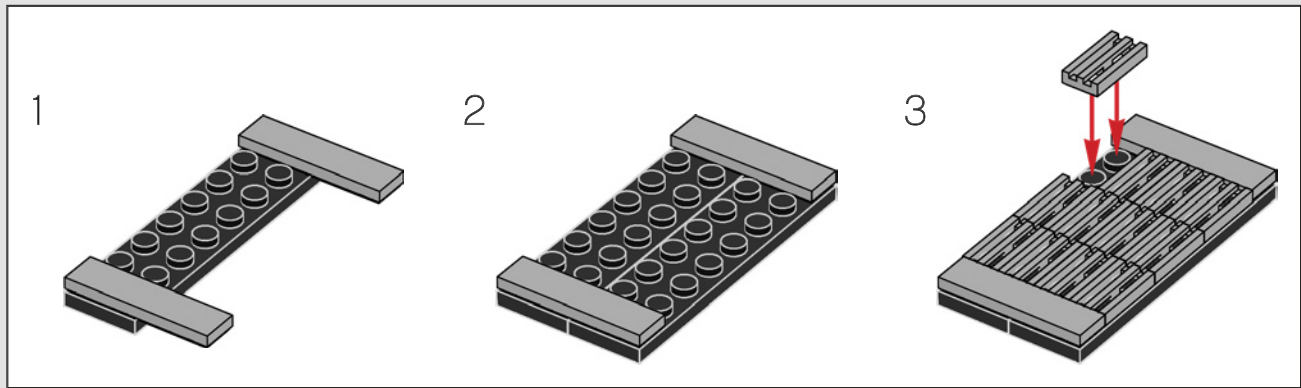

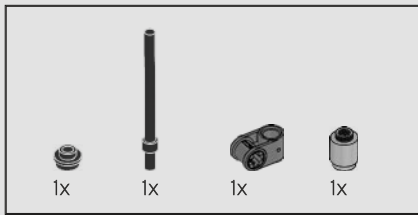

136

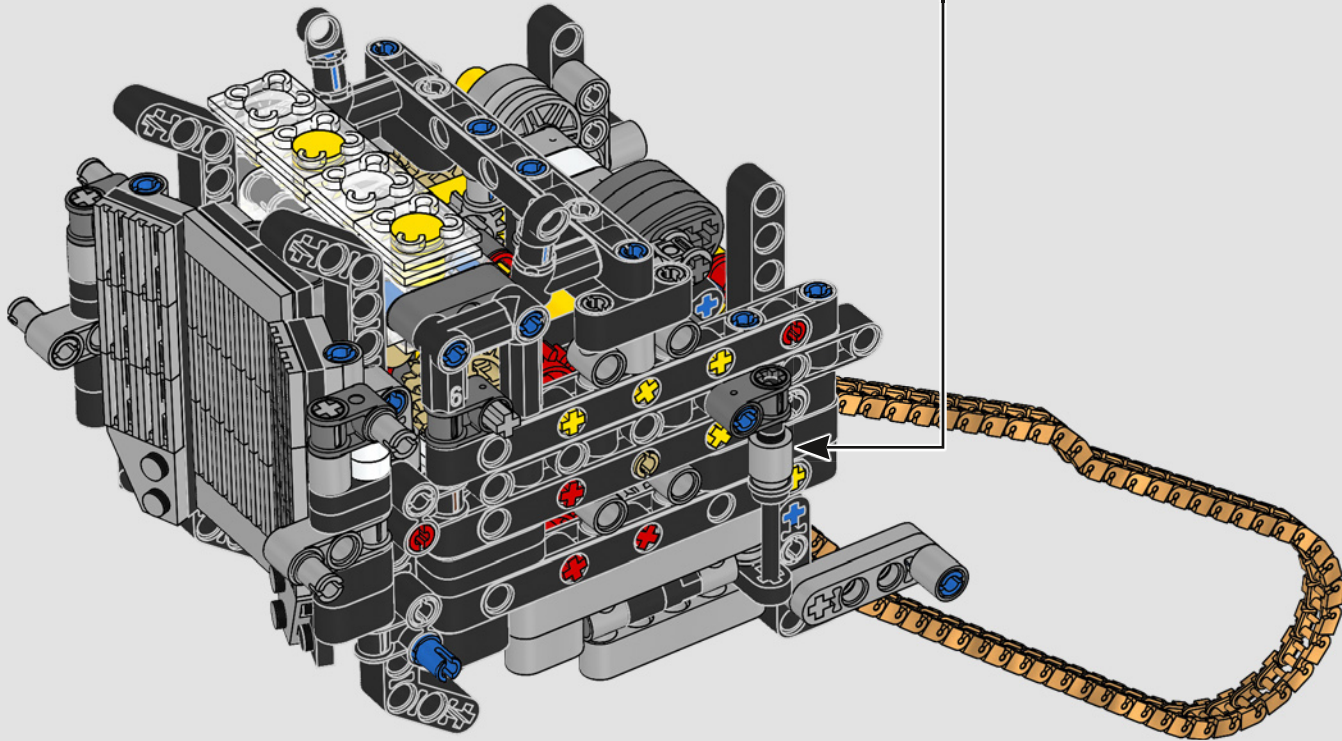
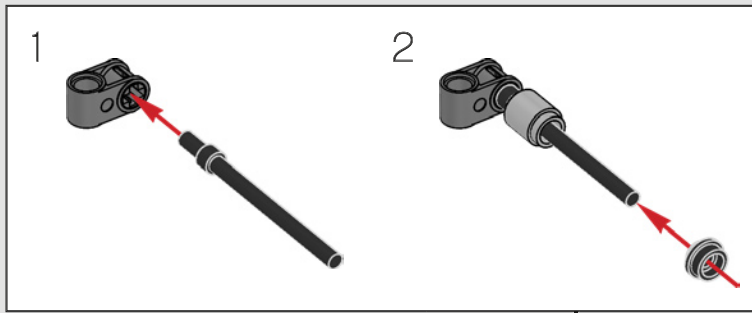

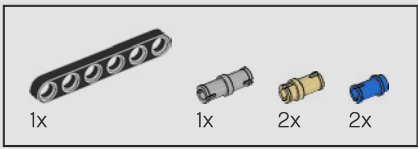

137

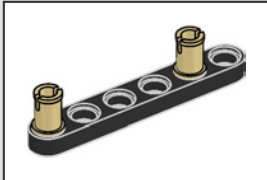
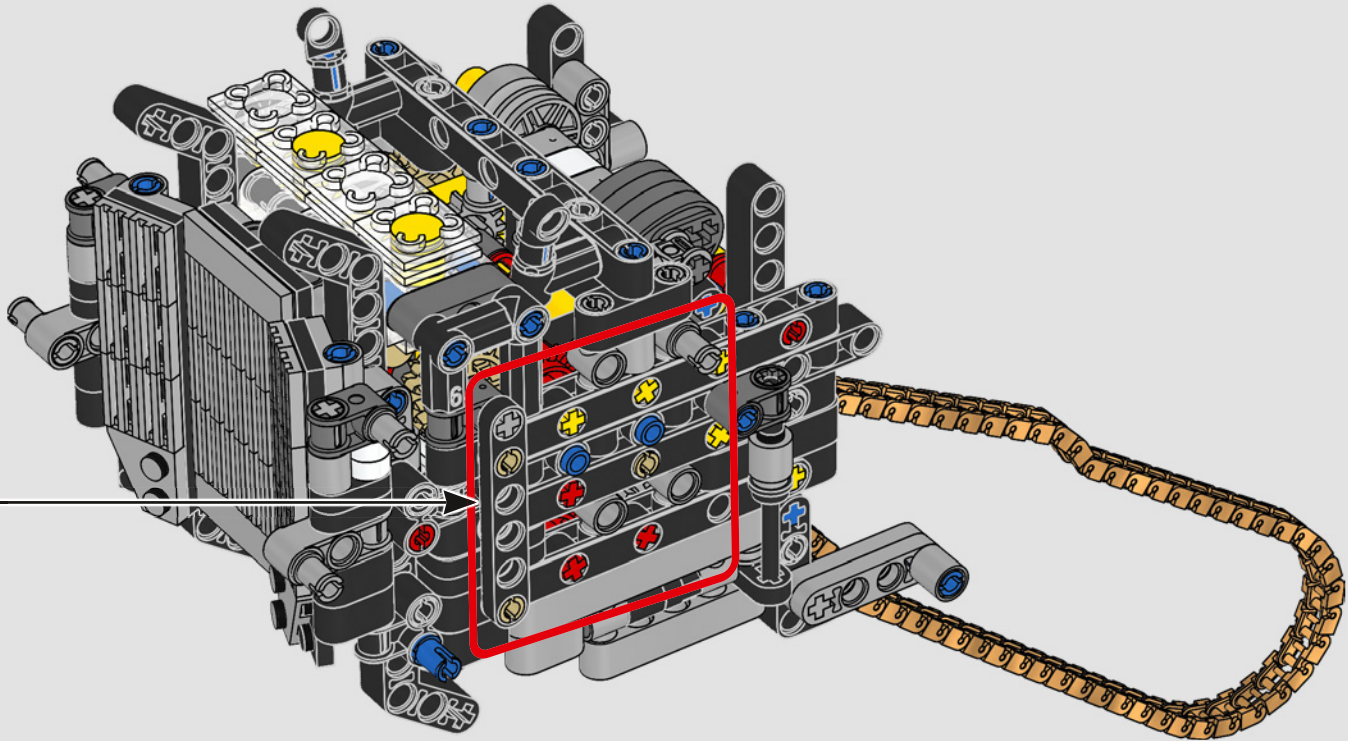

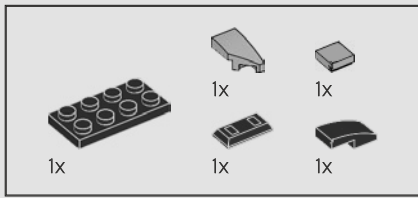

138

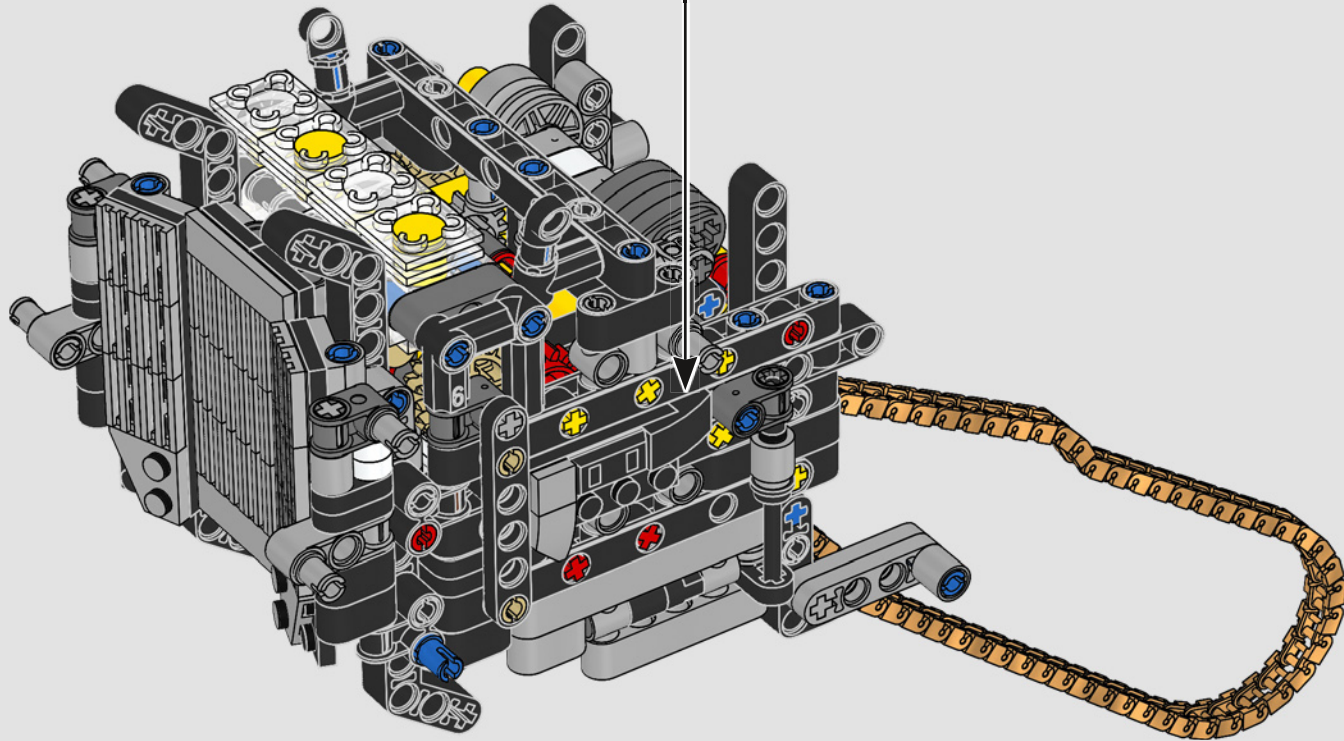
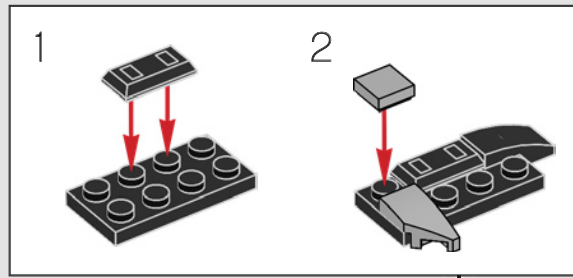

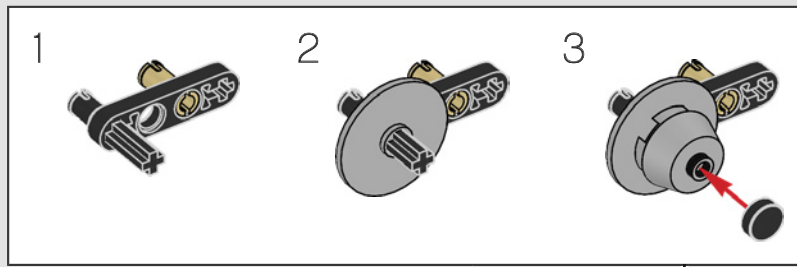
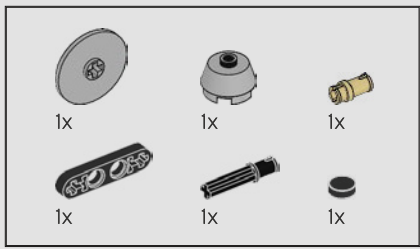

139

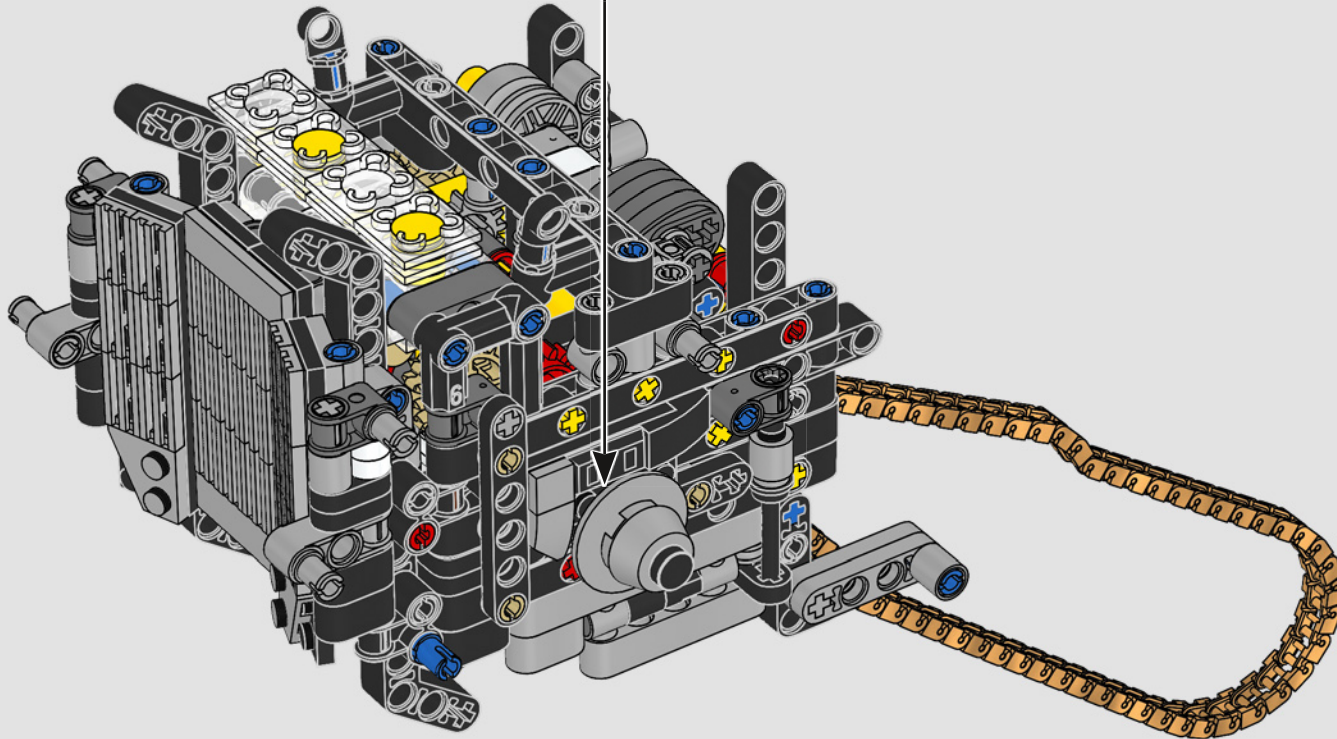

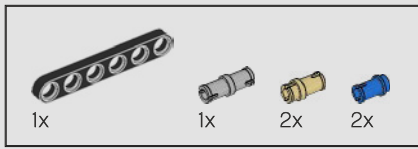

140

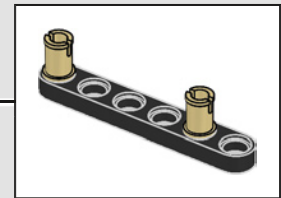
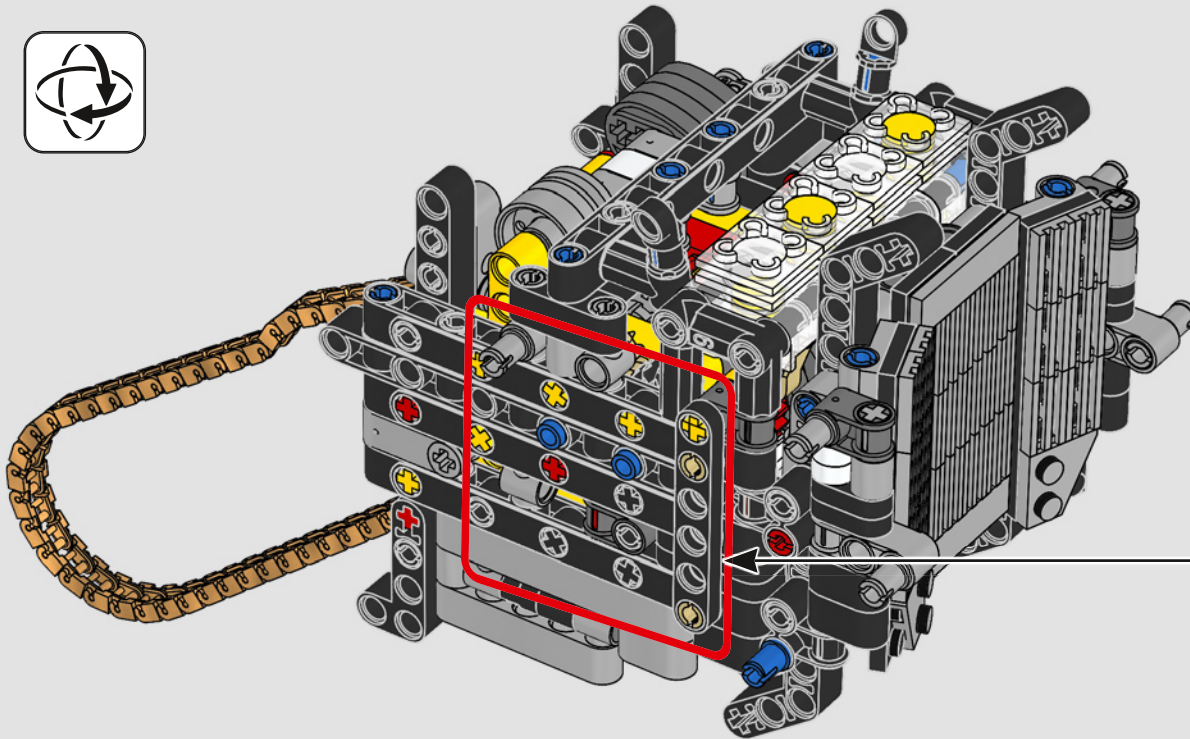

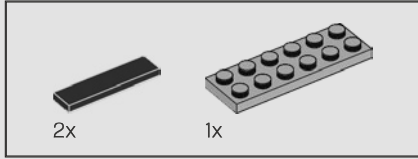
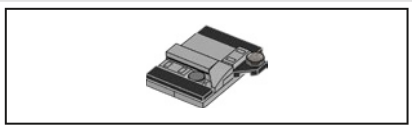

141

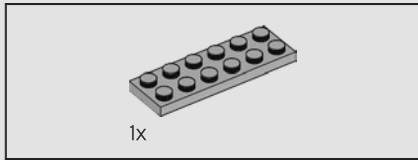
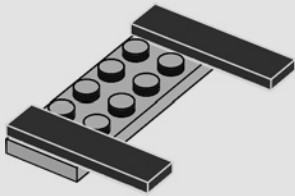

142

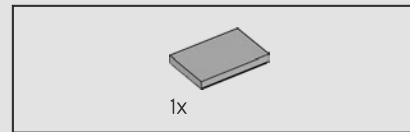
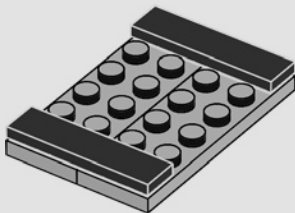

143

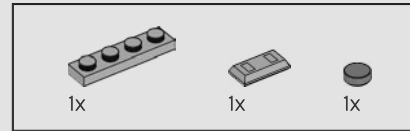
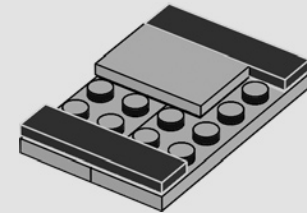

144

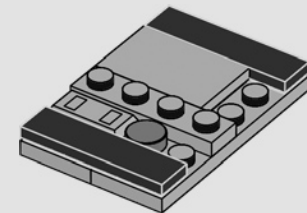

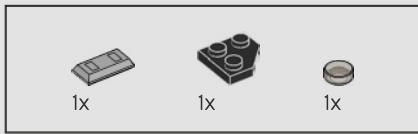

145

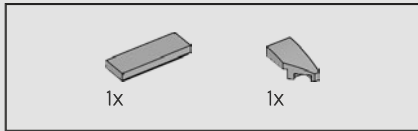
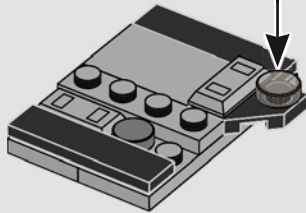
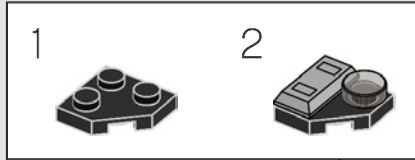

146

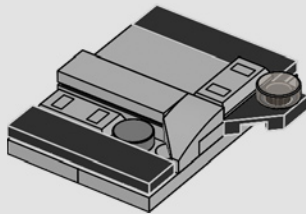

147

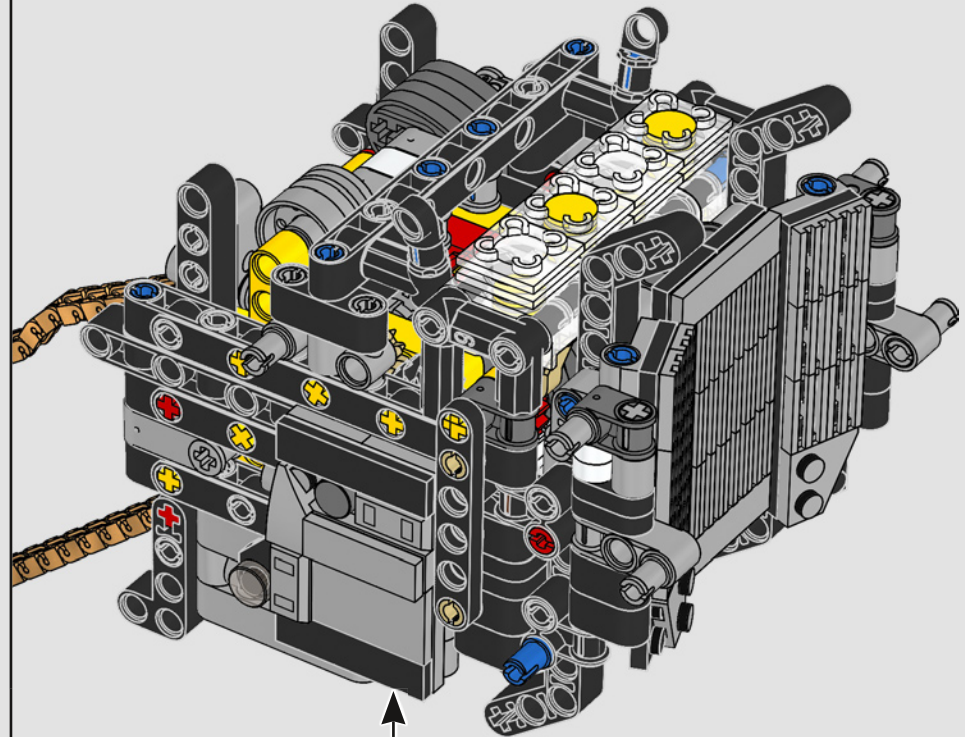

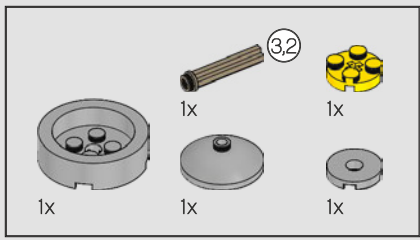

148

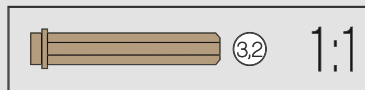
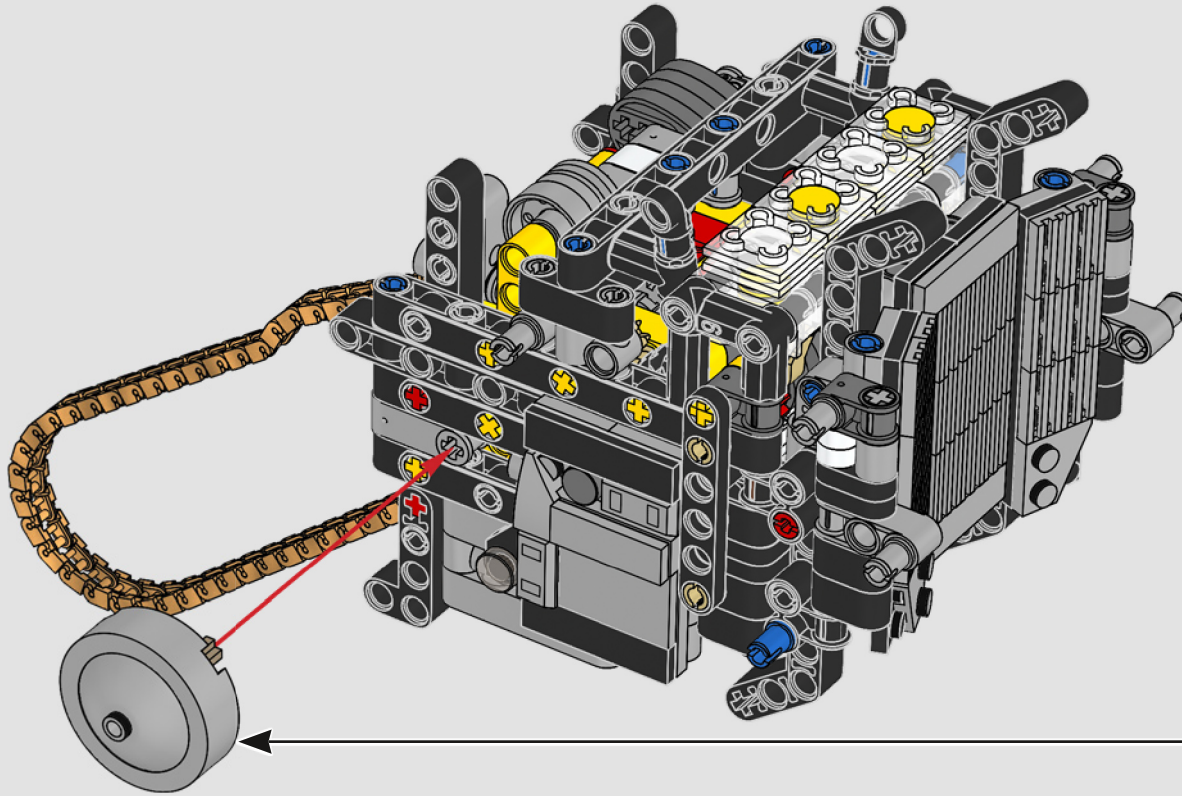
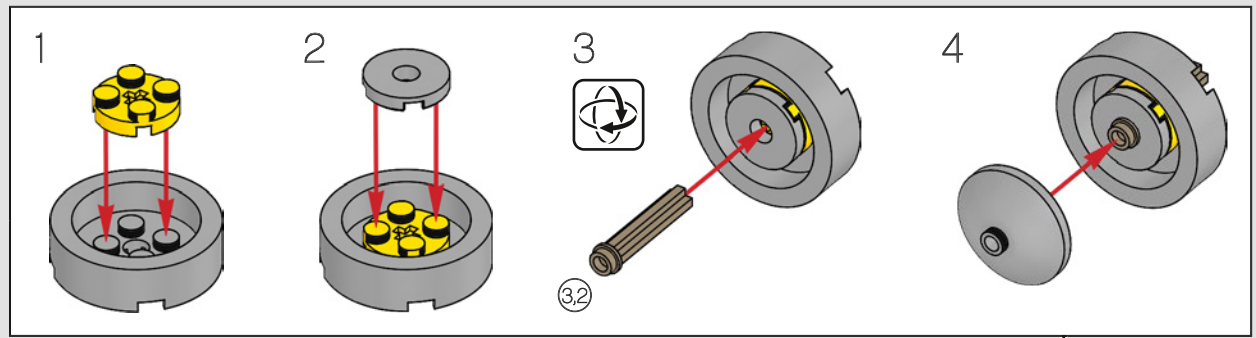

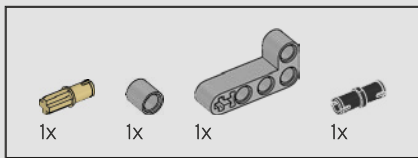

149

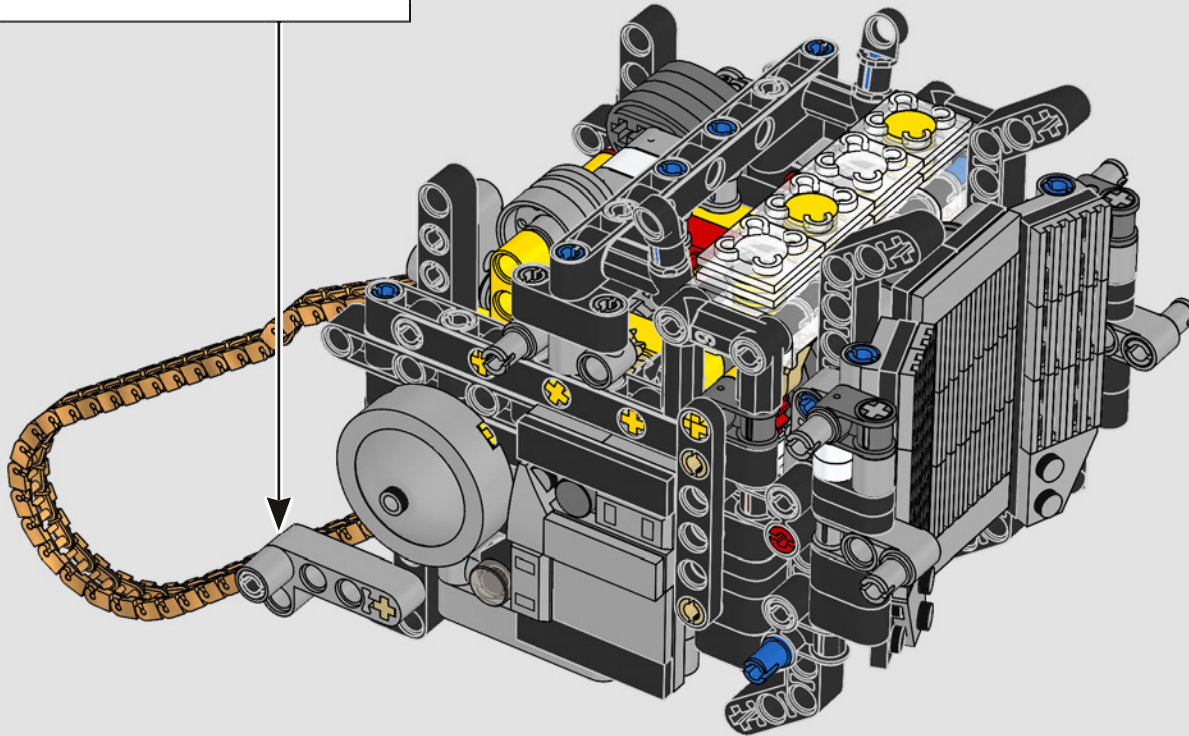
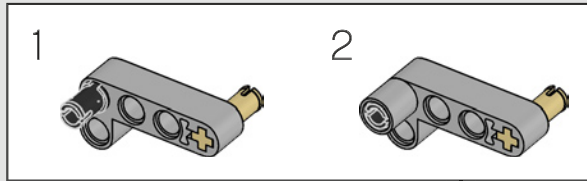

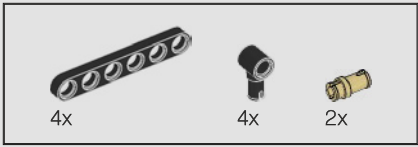

150

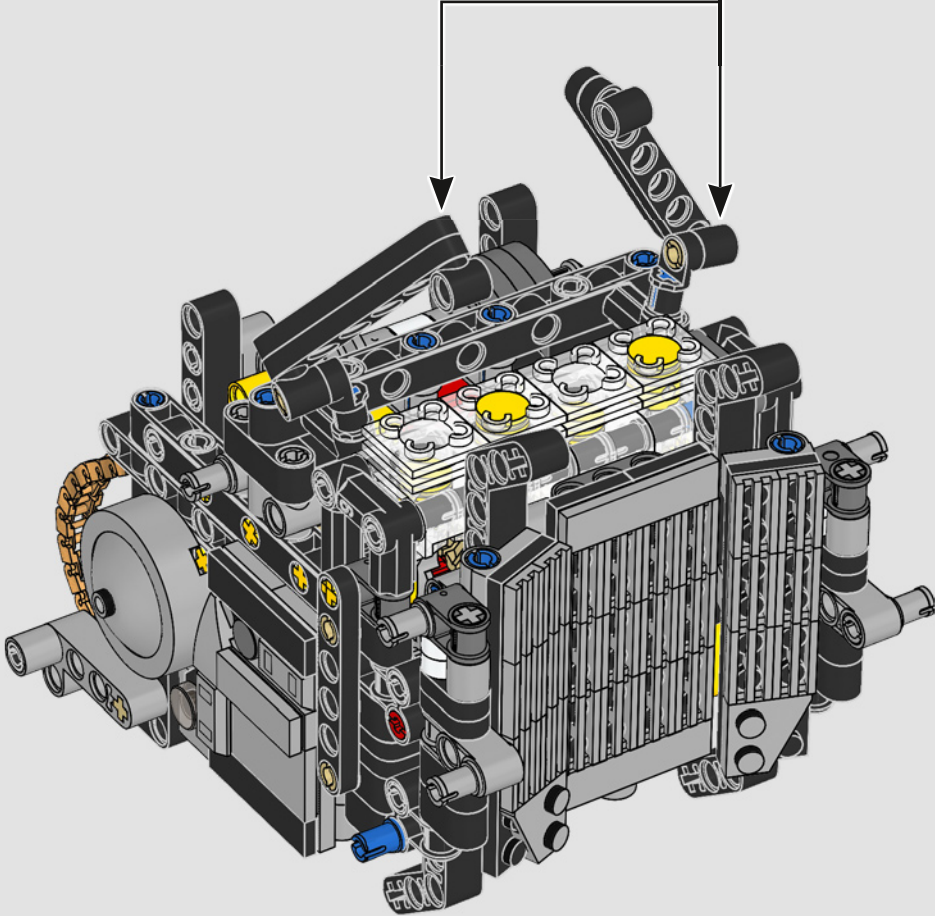
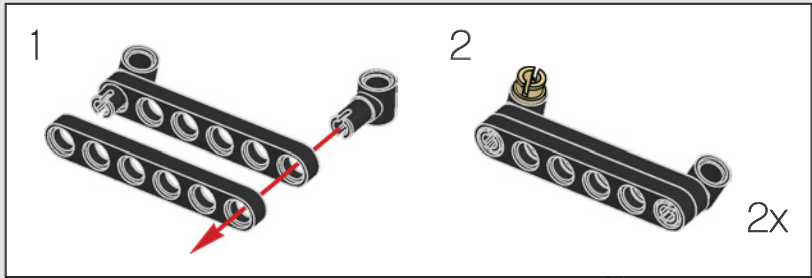

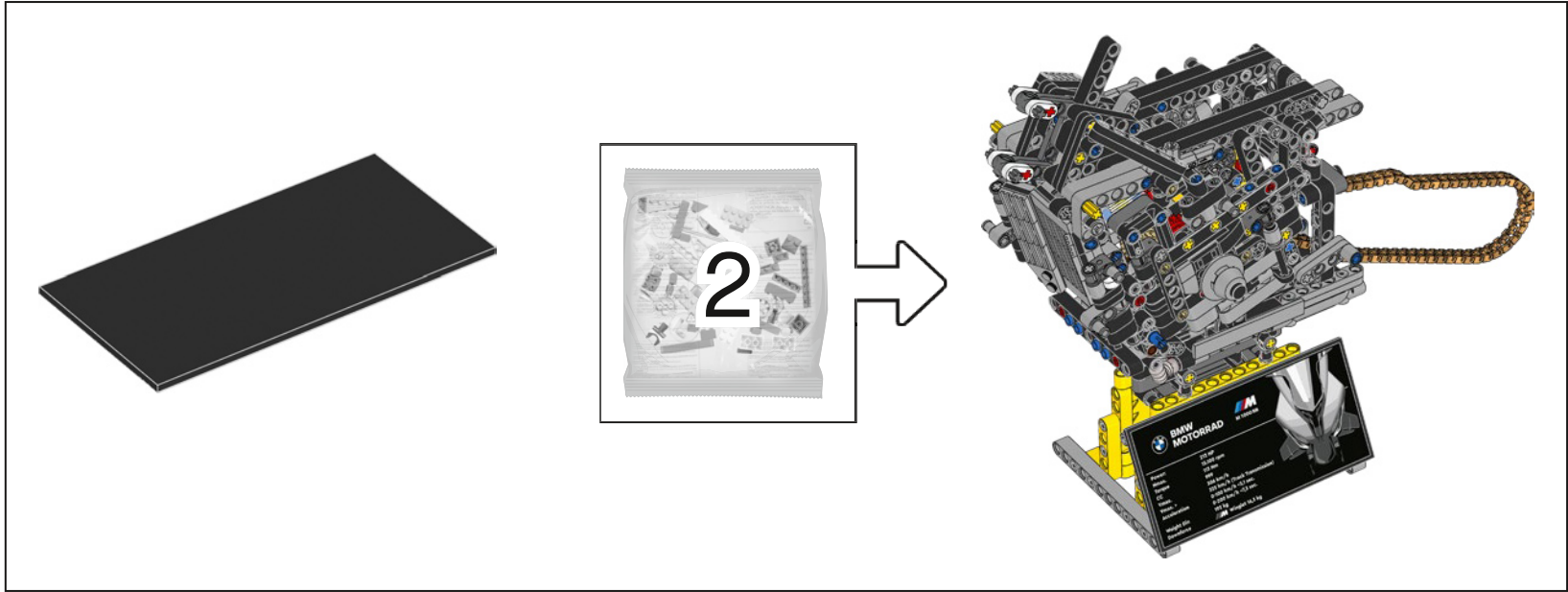

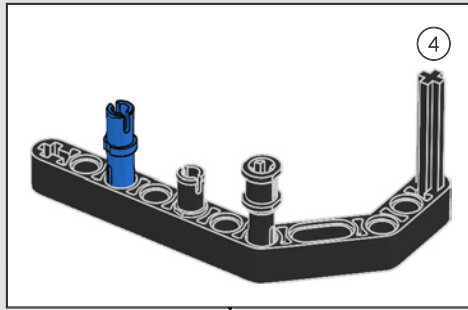
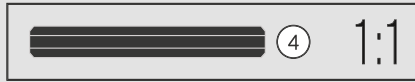
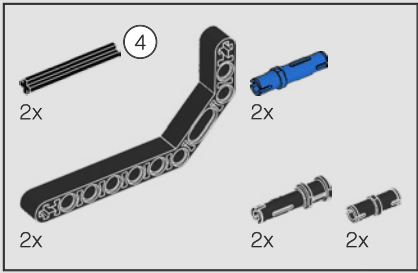

151

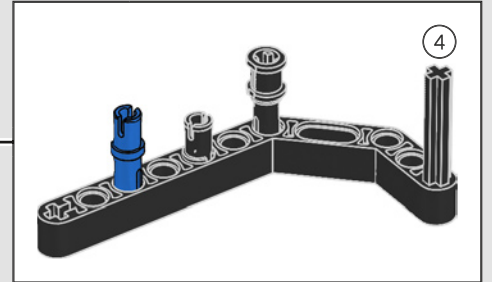
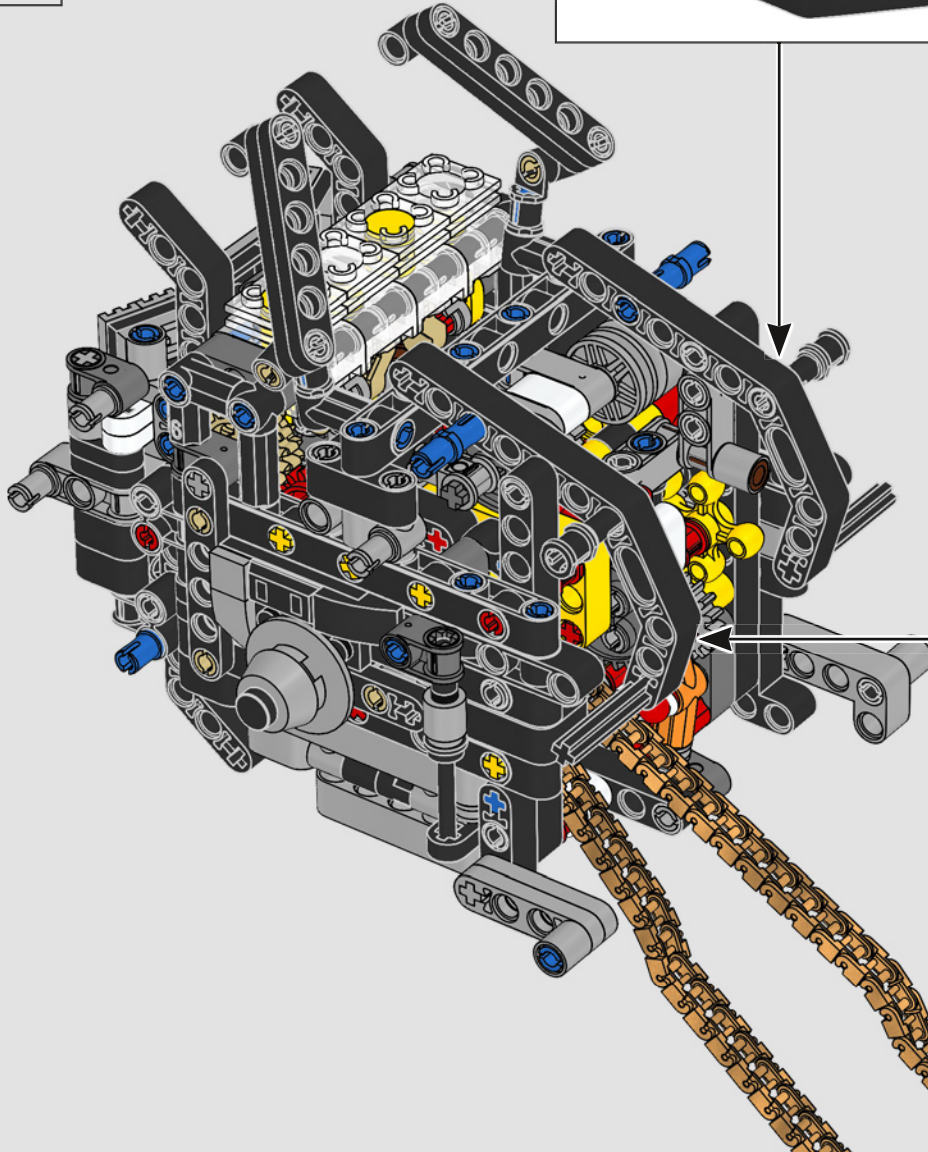

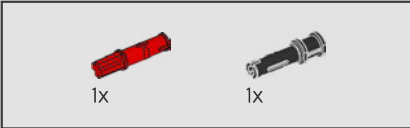
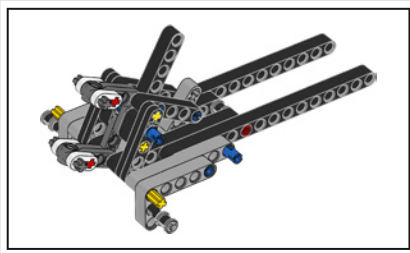

152

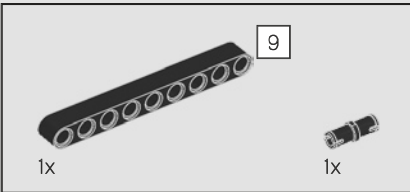
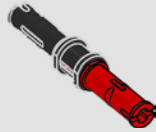

153

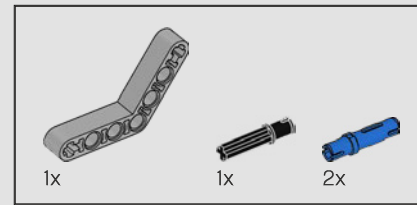
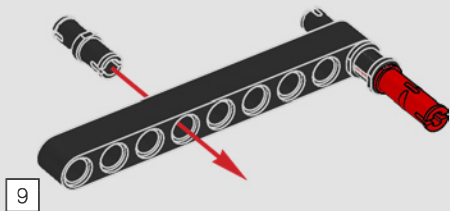

154

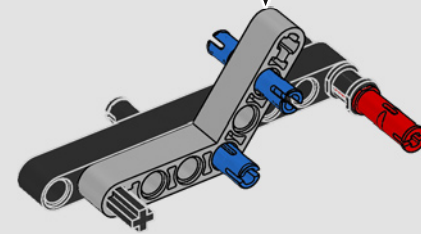
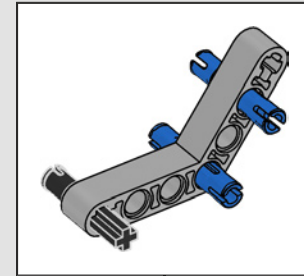

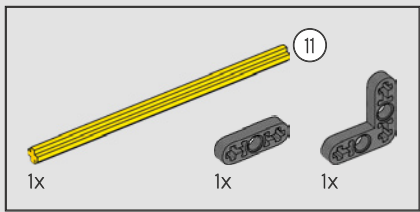

155

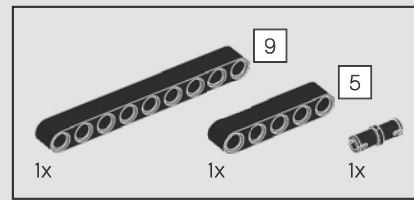
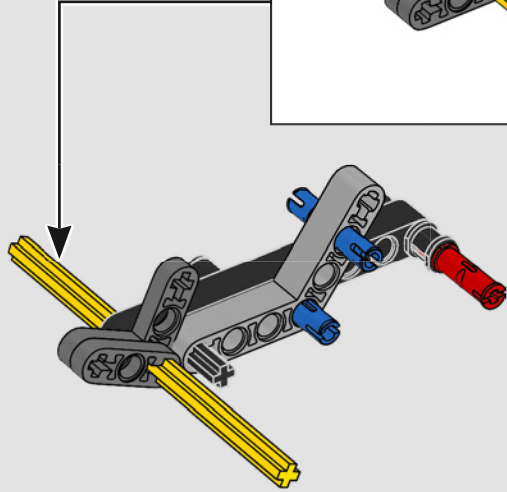
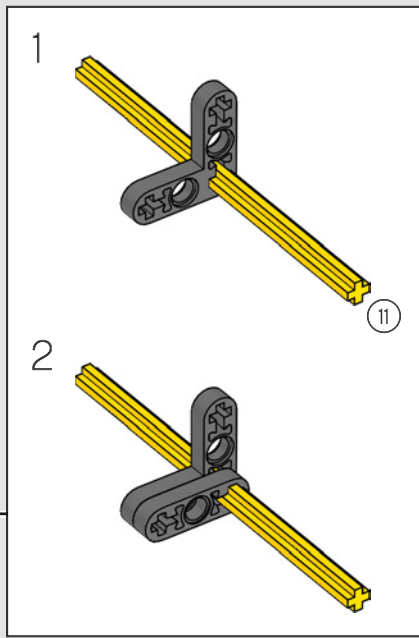

156

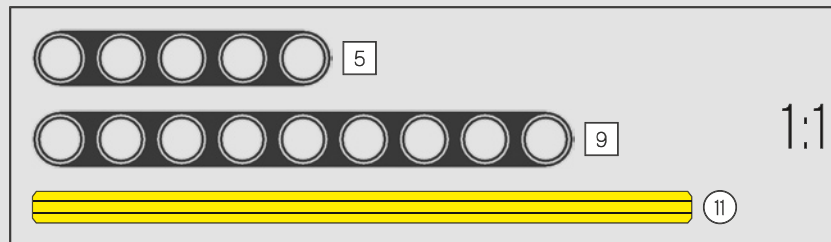
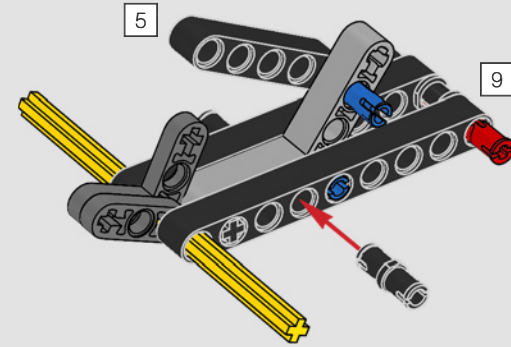

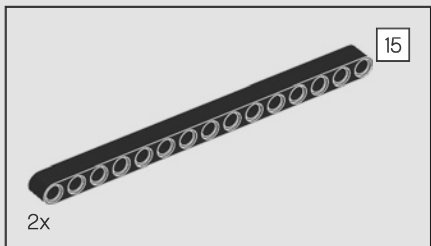

157

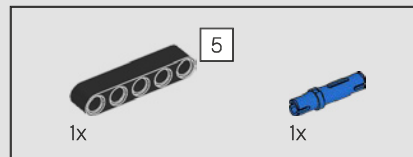
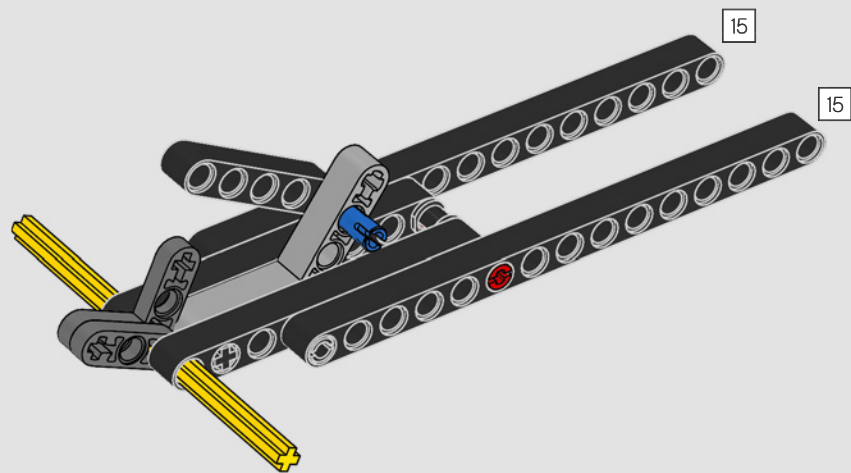

158

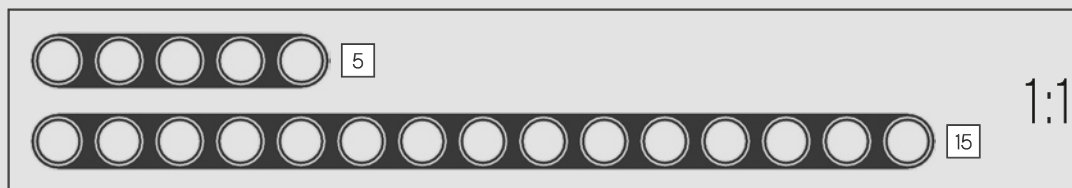
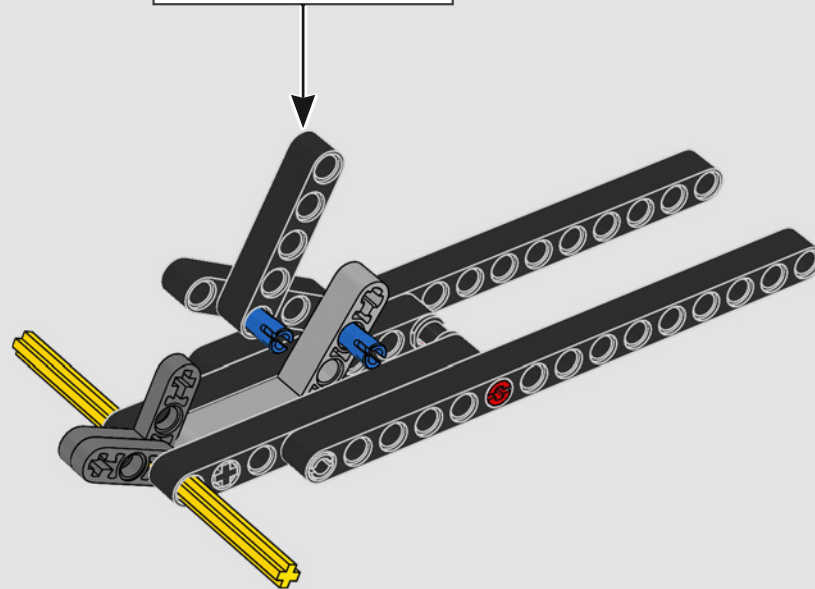
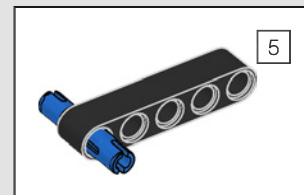

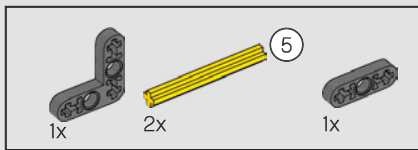

159

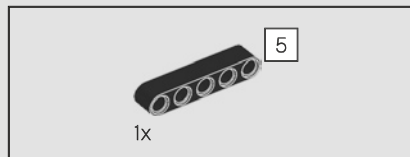
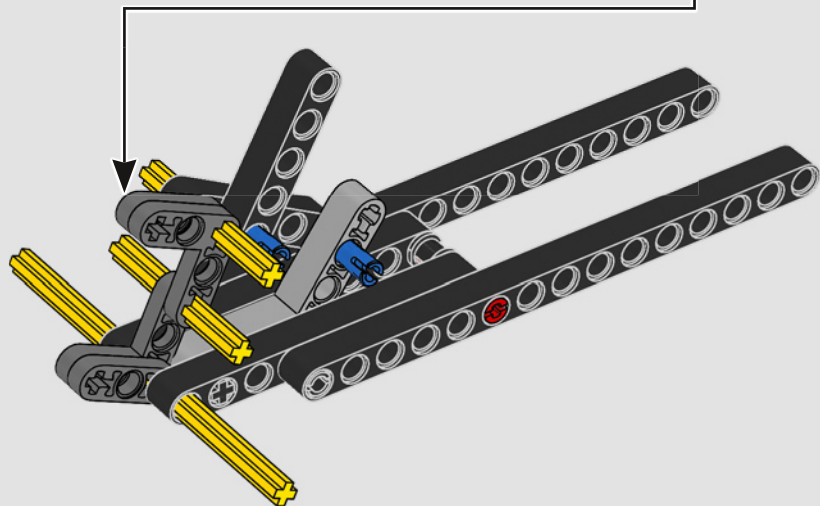
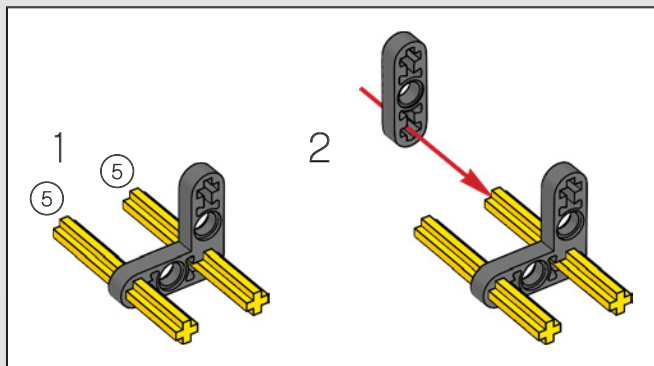

160

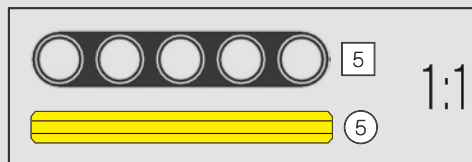
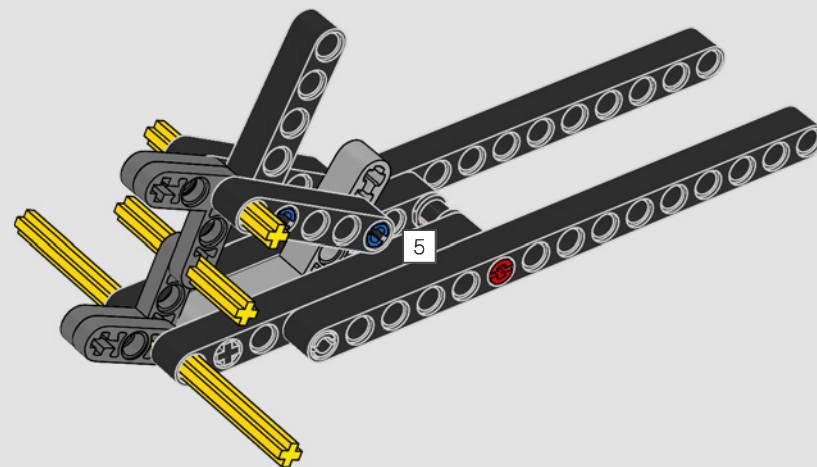



161

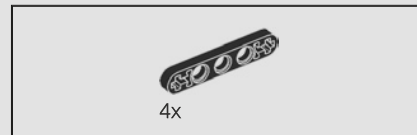
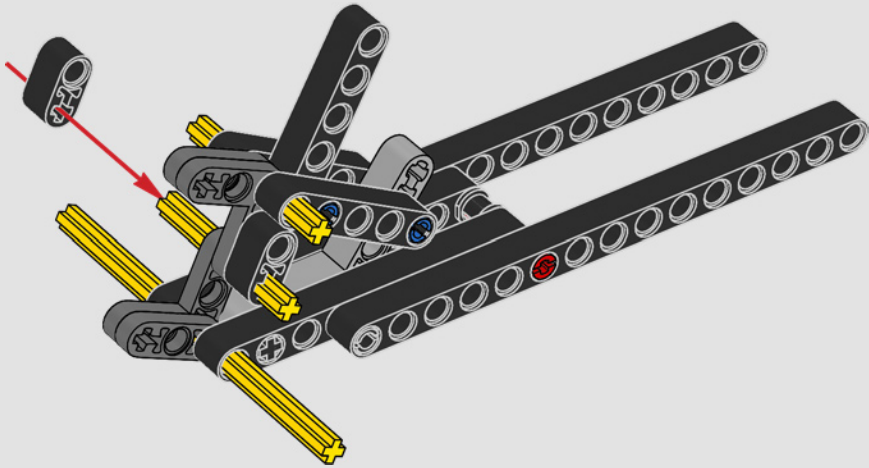

162

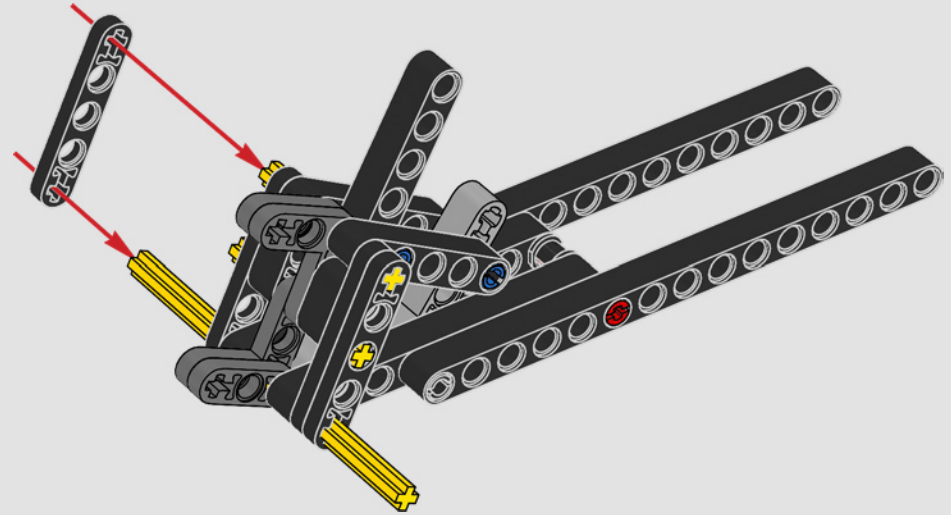

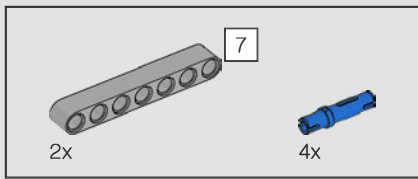

163

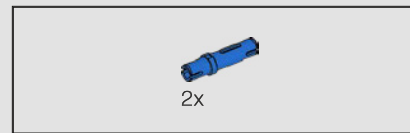
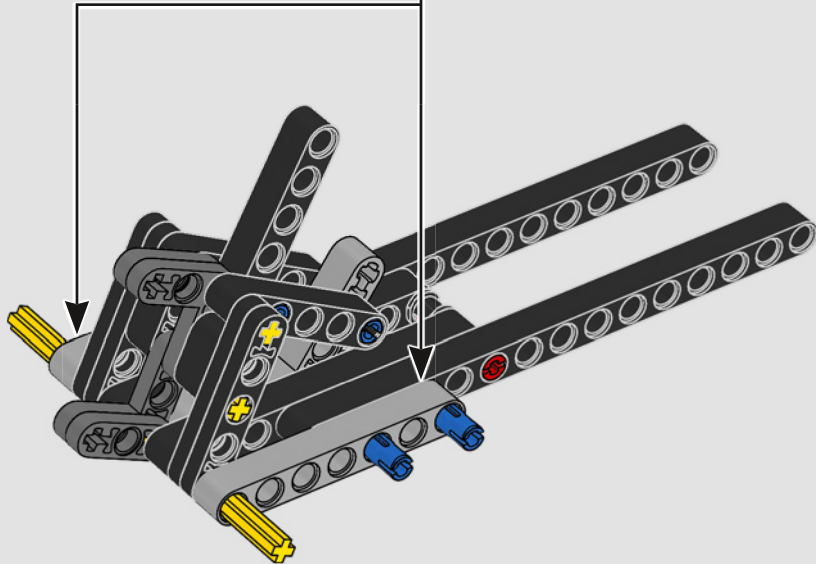
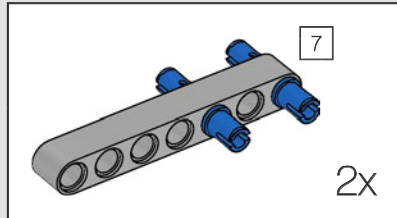

164

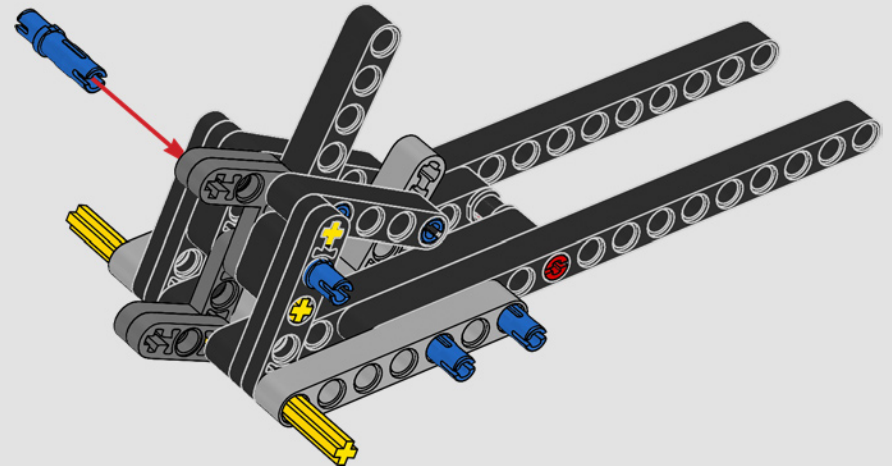

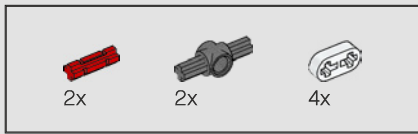

165

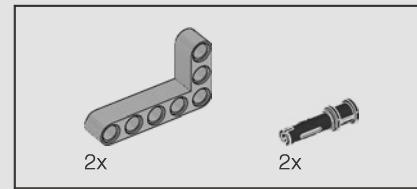
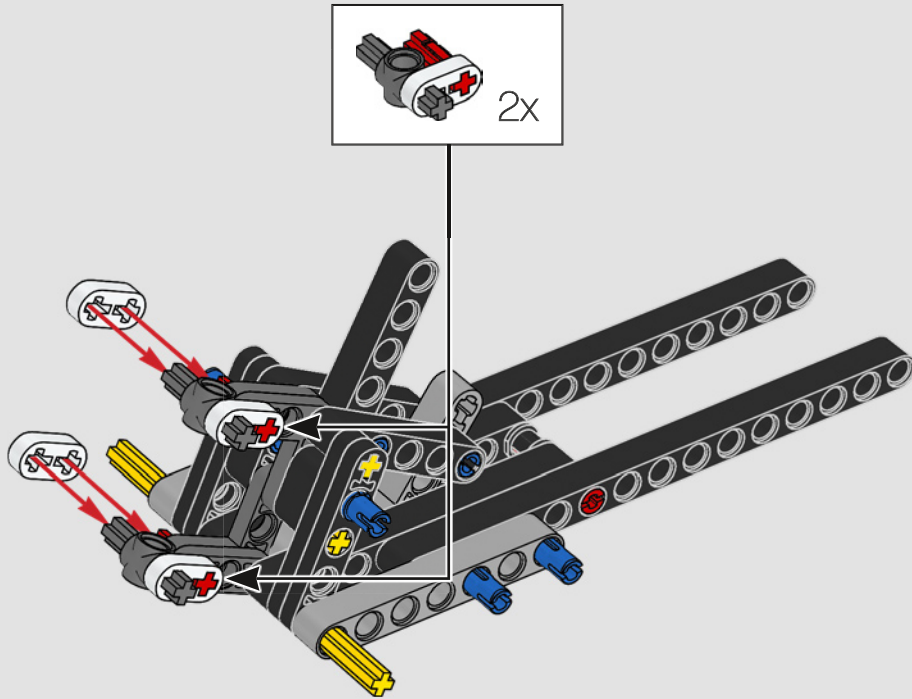

166

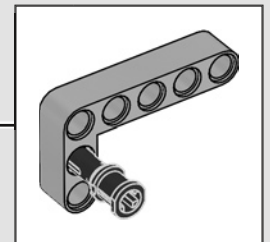
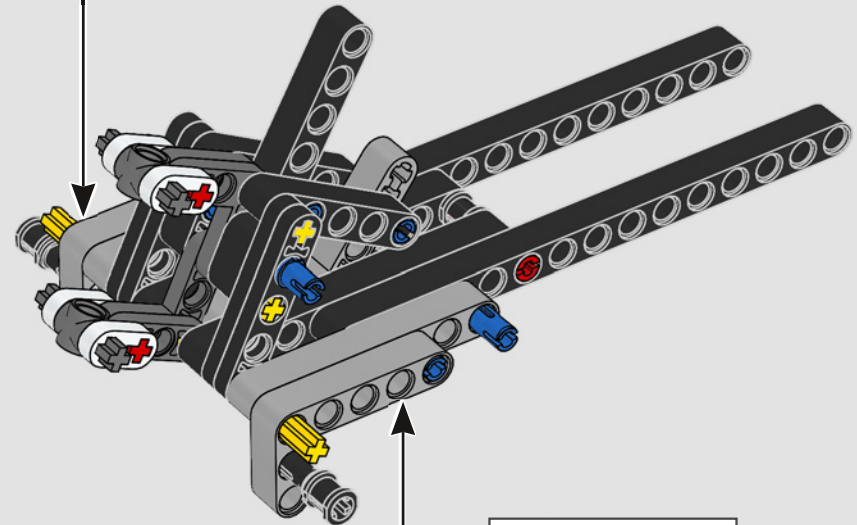
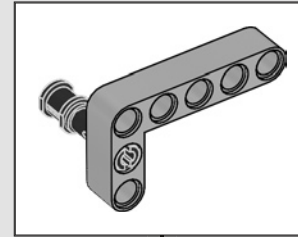

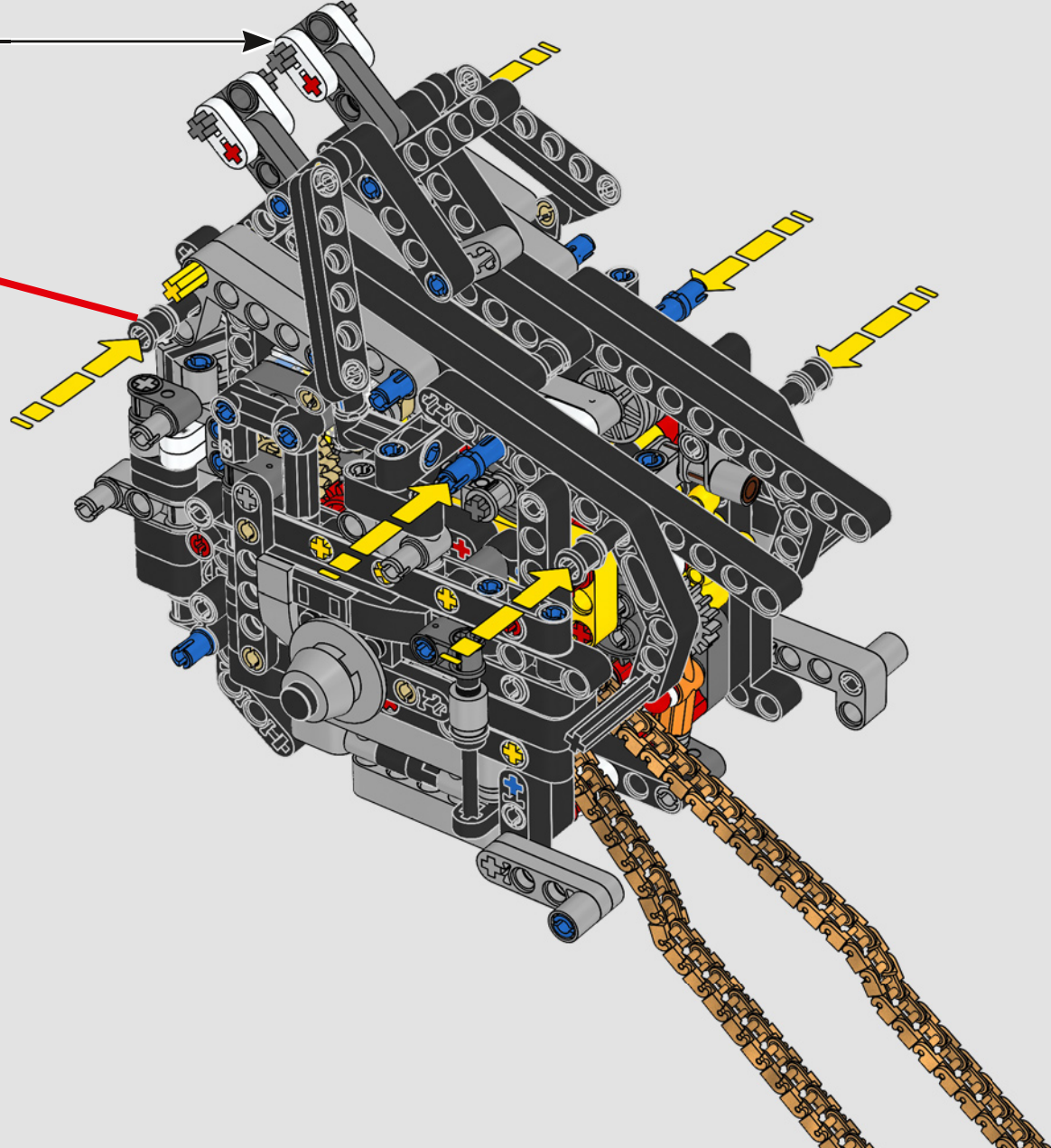
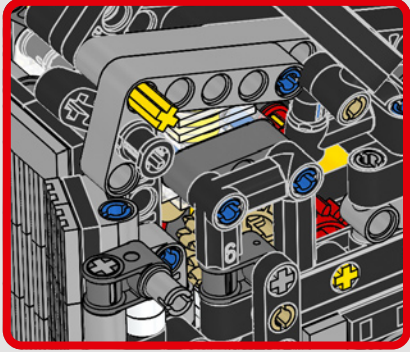

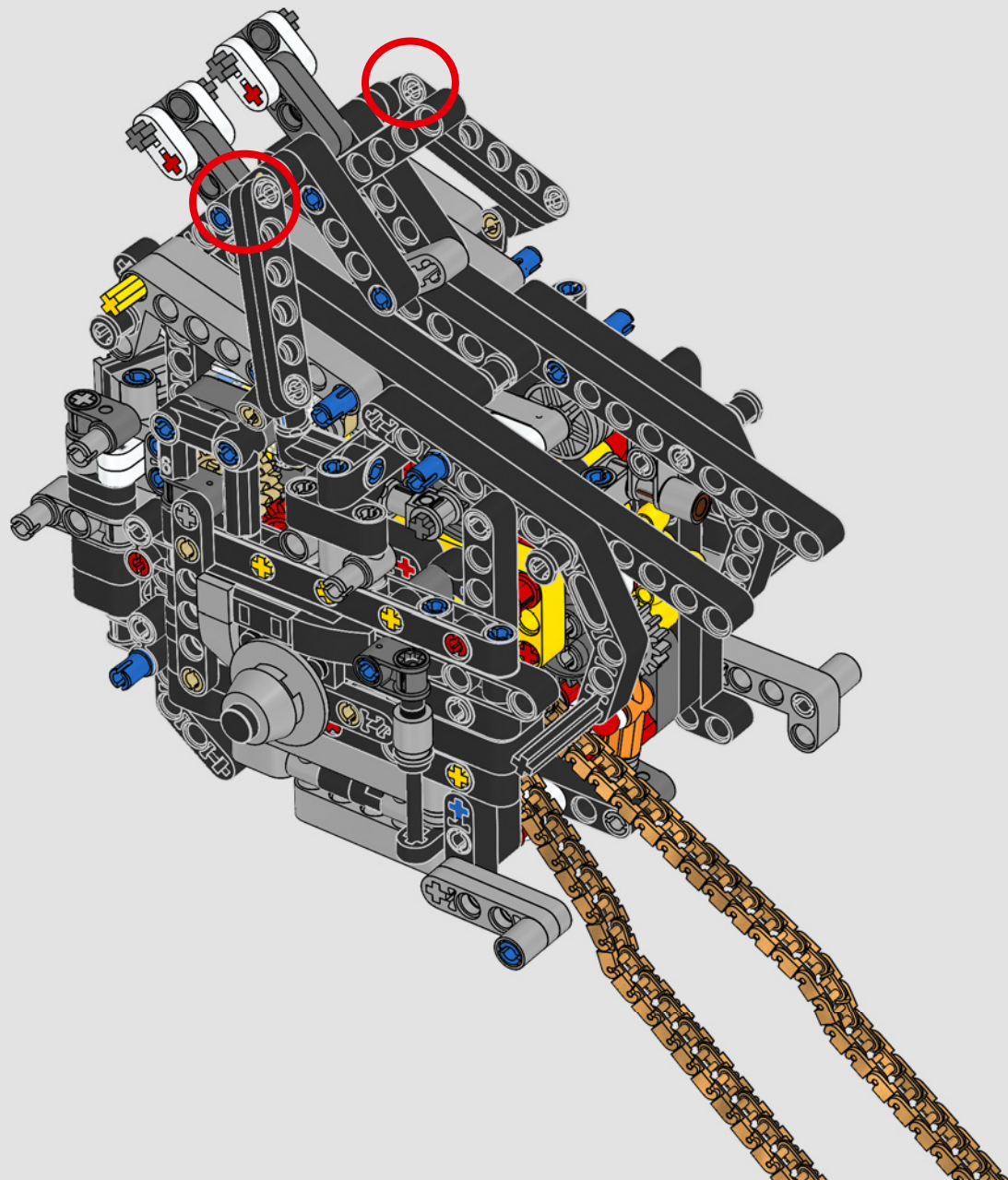

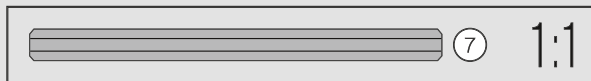
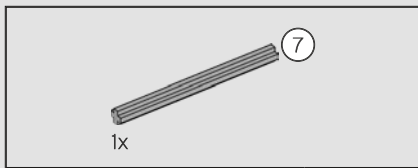

169

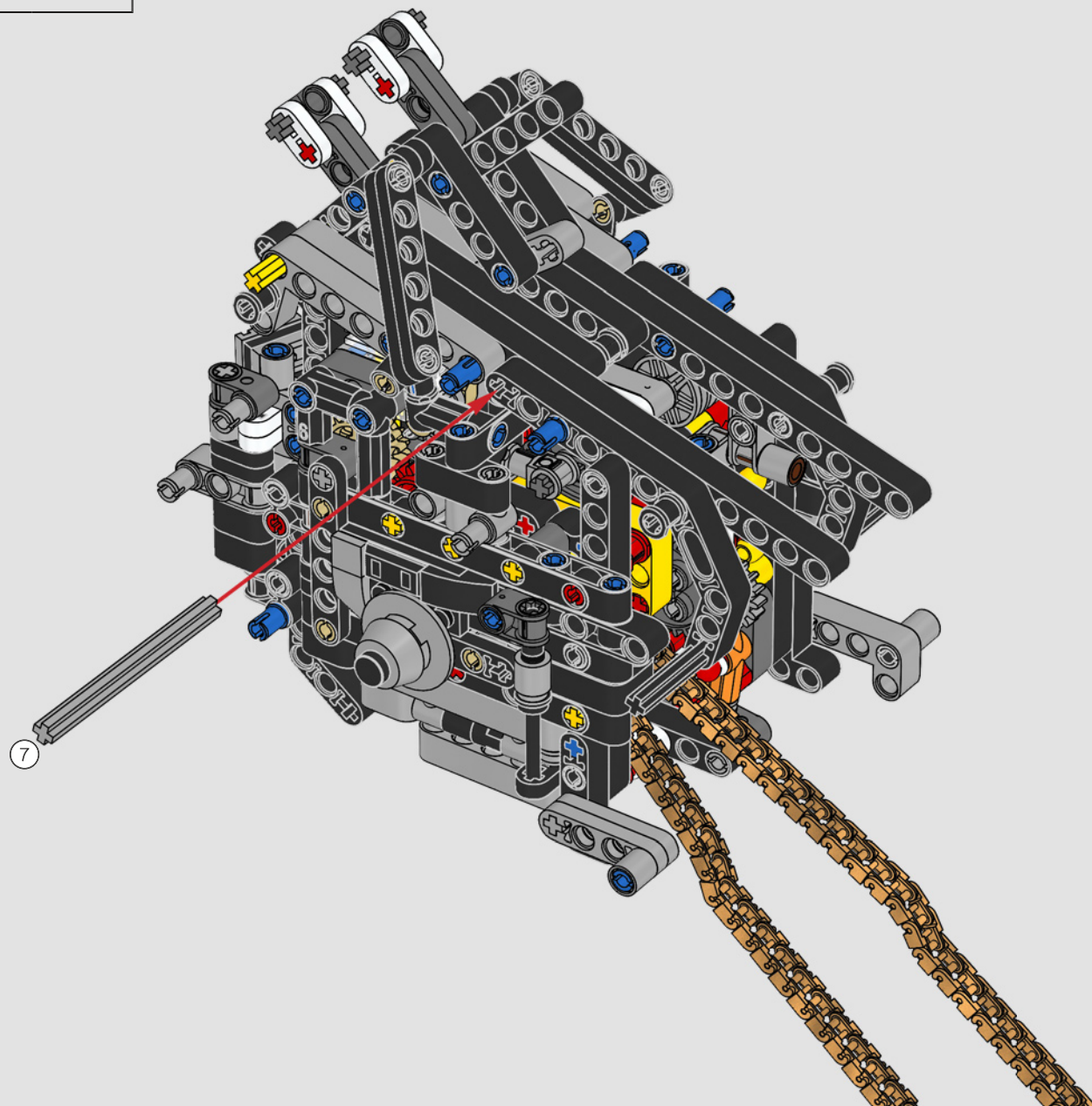



170

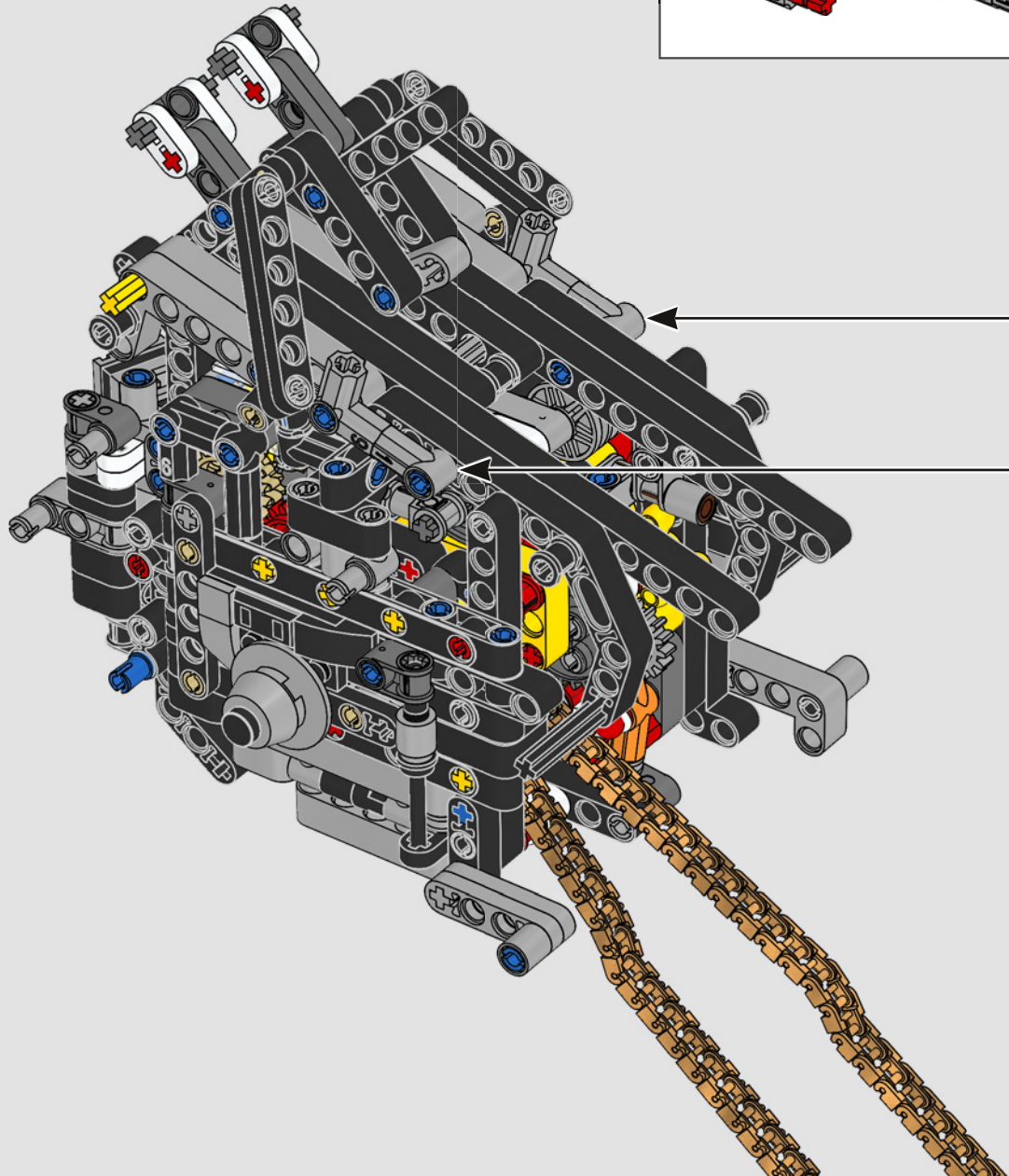
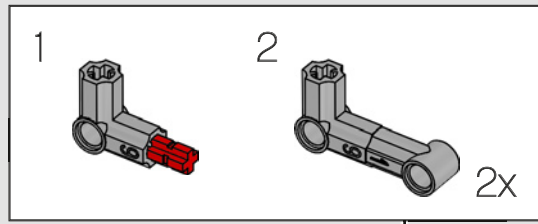

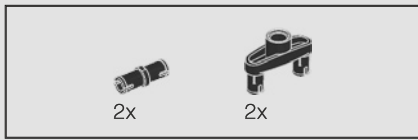

174

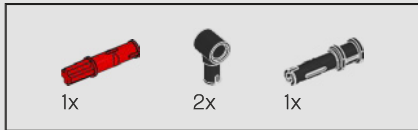
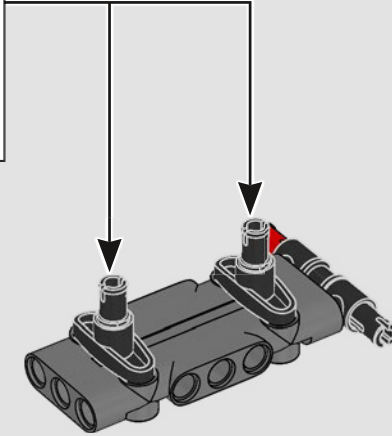
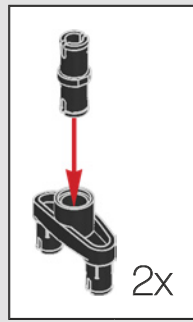

175

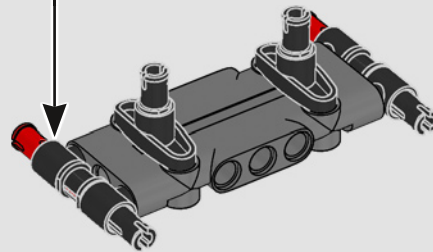
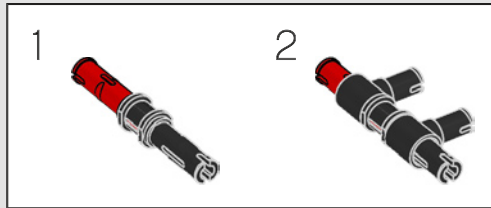

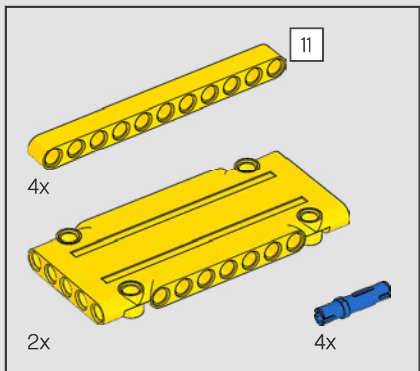

176

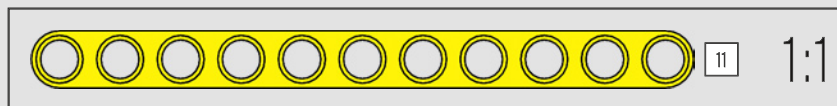
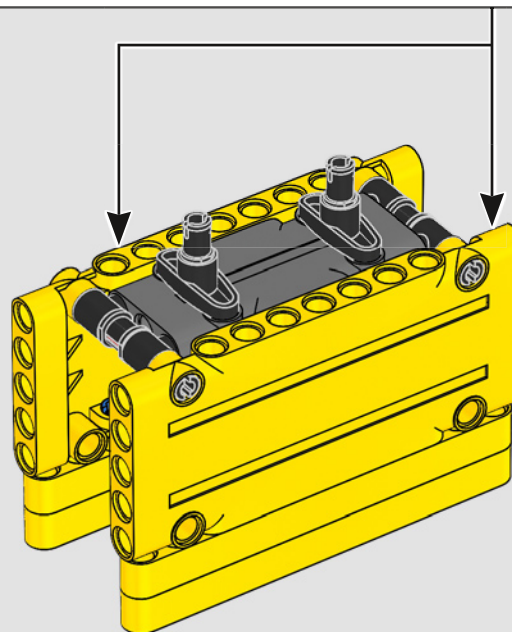
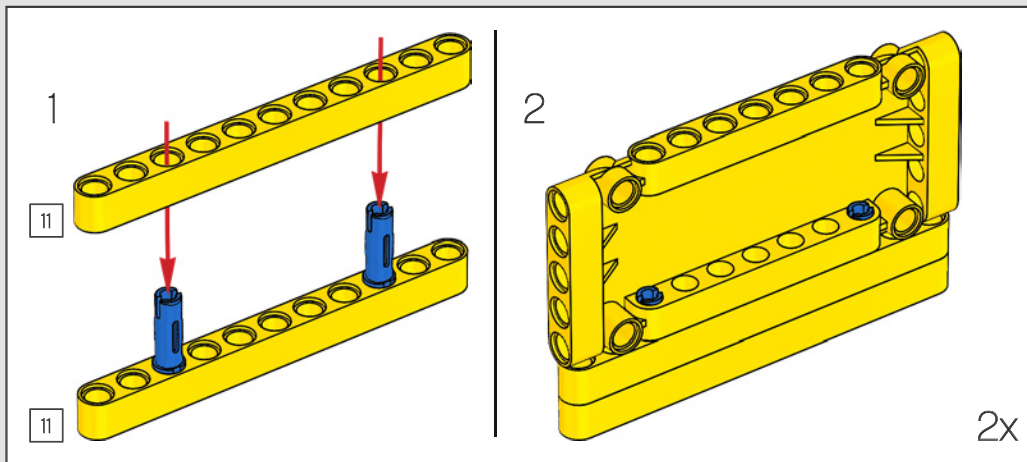

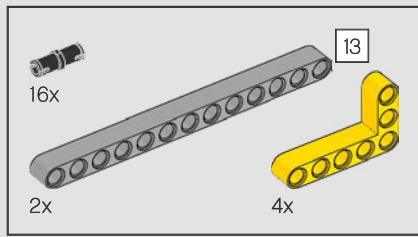

177

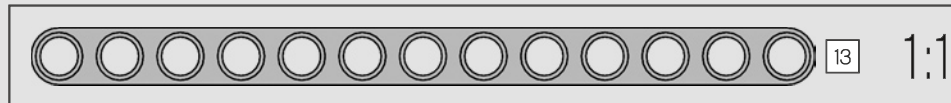
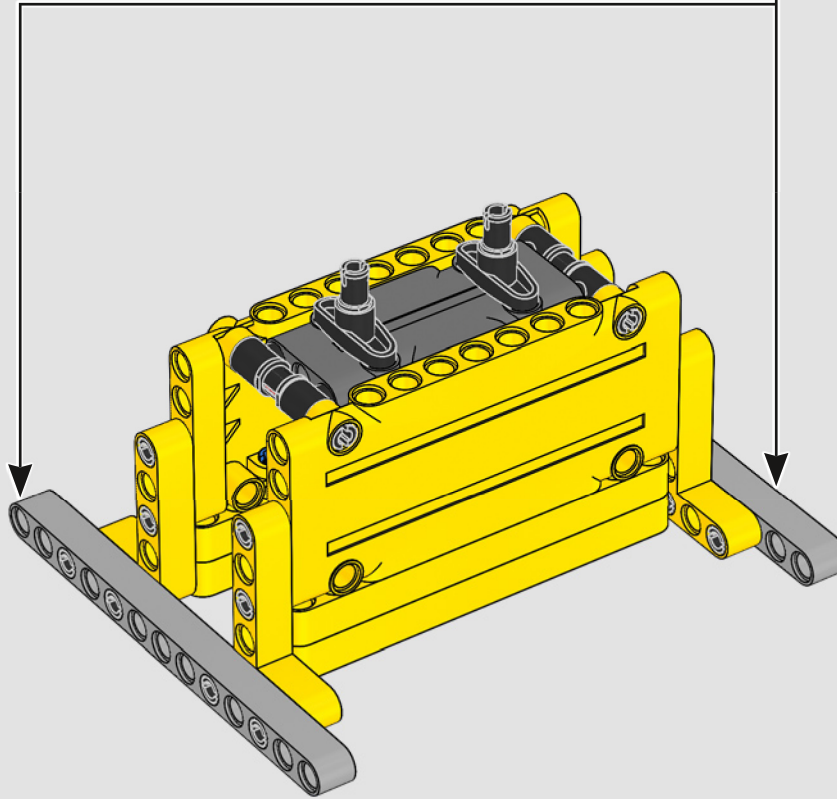
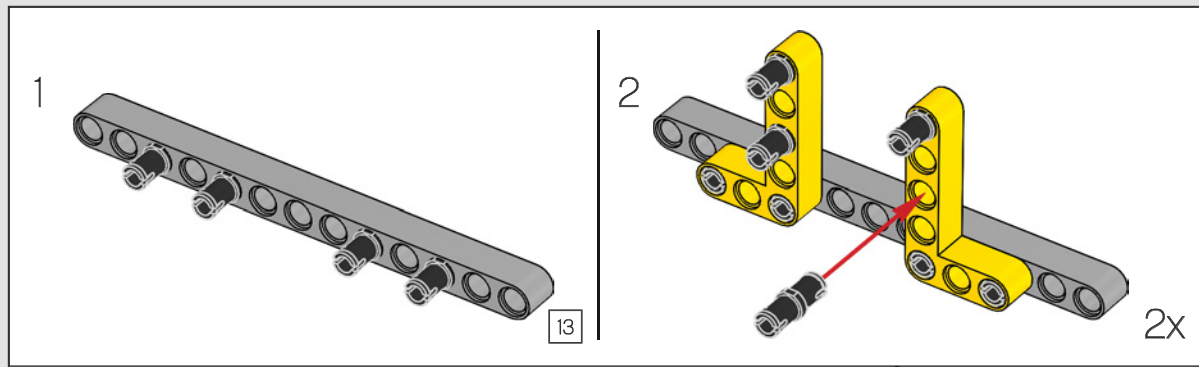

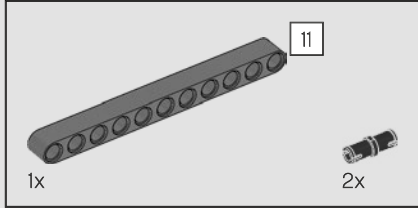
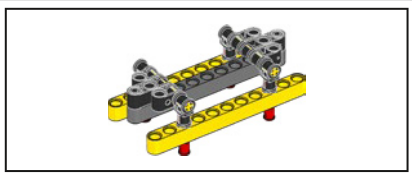

178

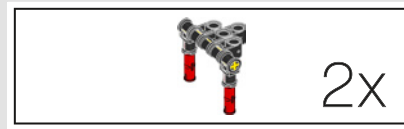
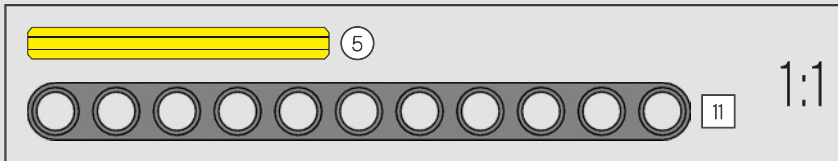
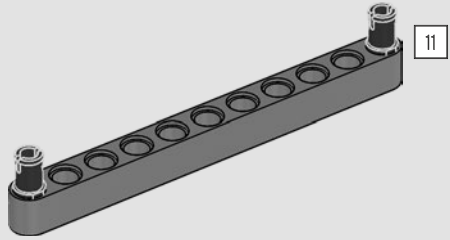

2x

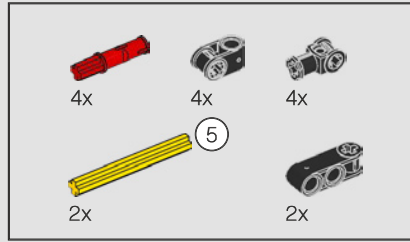

179

1

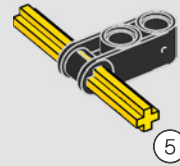

2

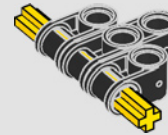

3

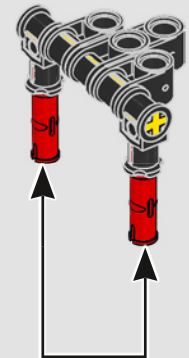

2x

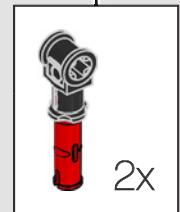

180

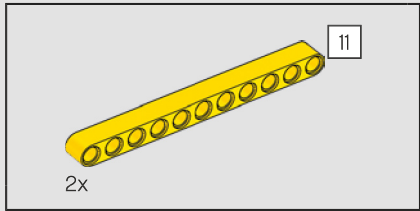
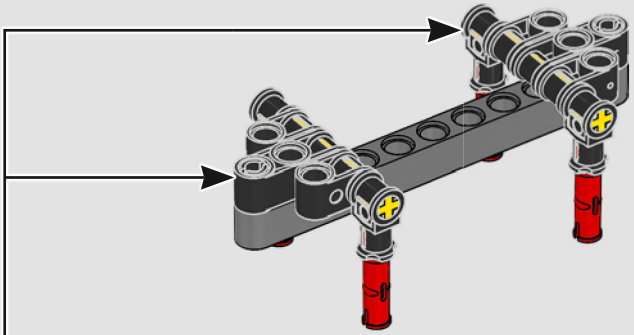

181

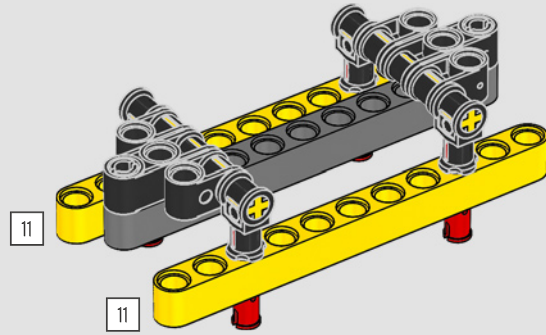

182

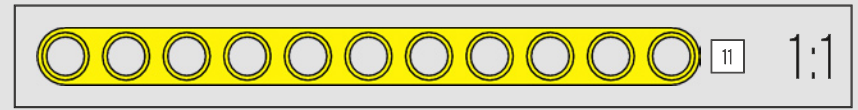
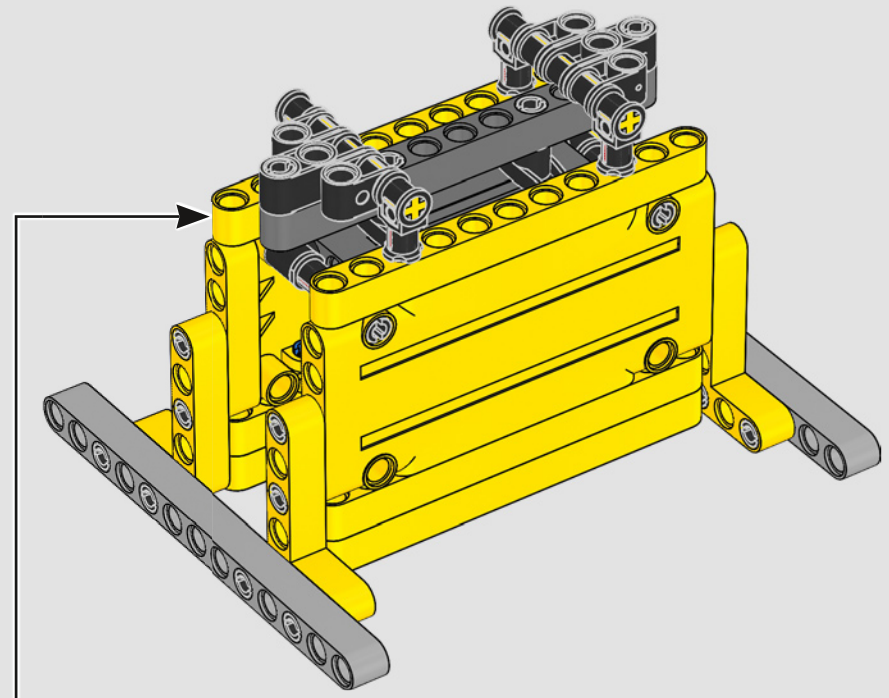

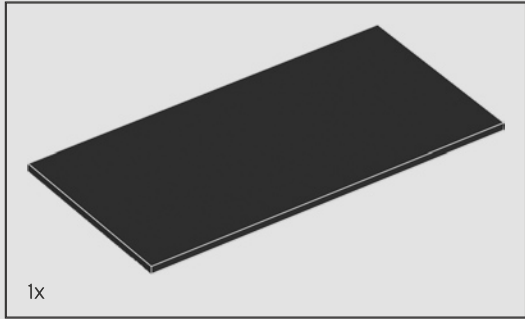
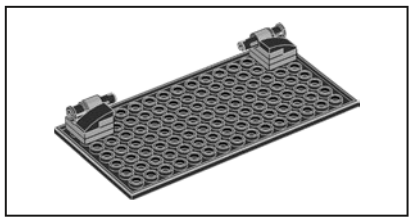

1x

183

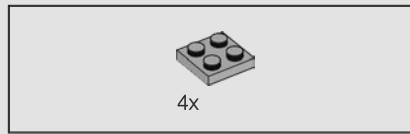
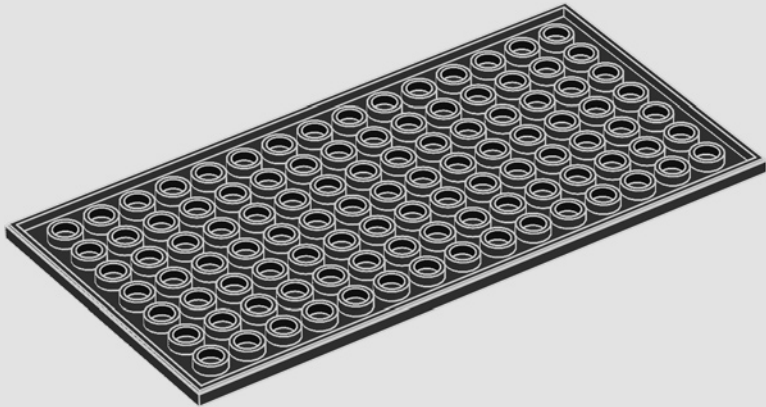

4x

184

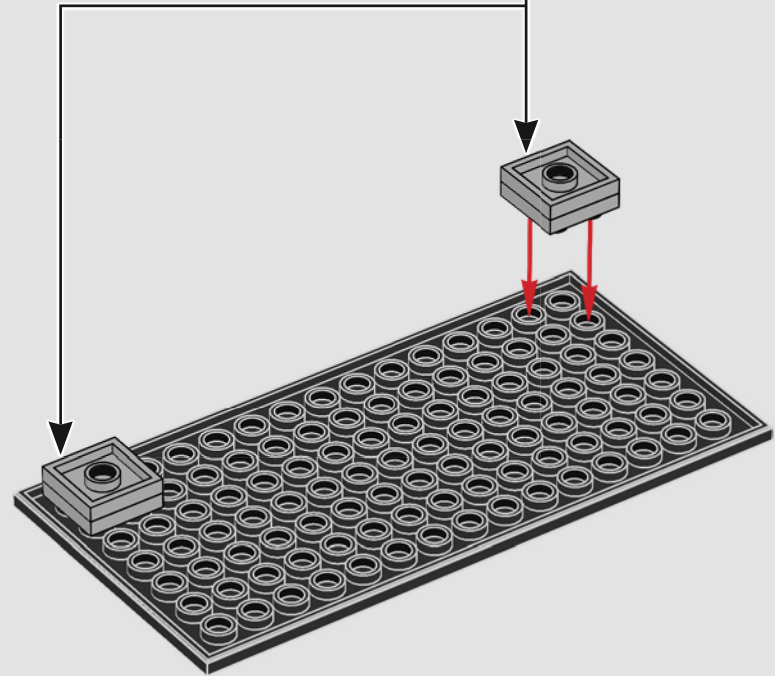
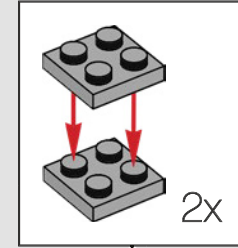

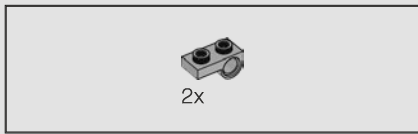

185

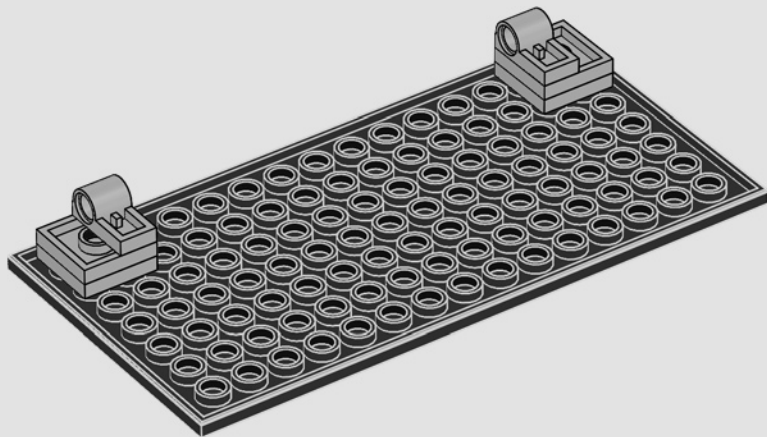

186

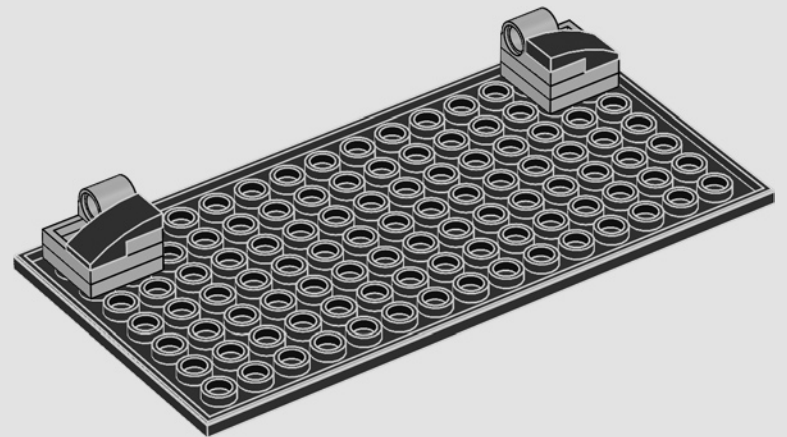

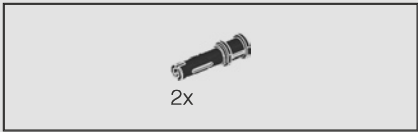

187

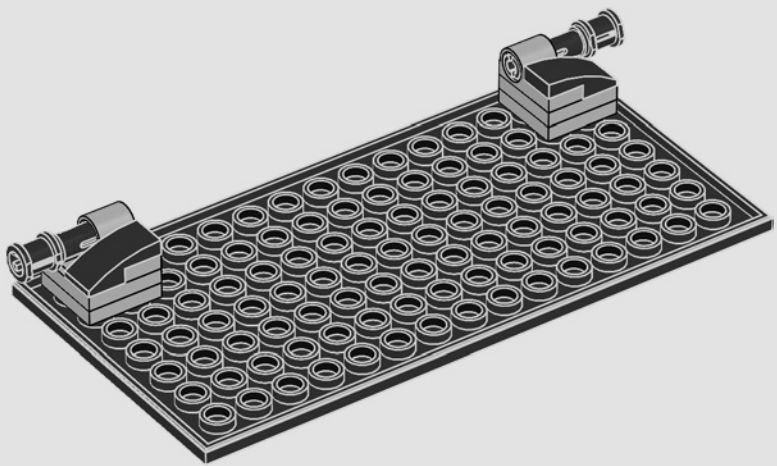

188

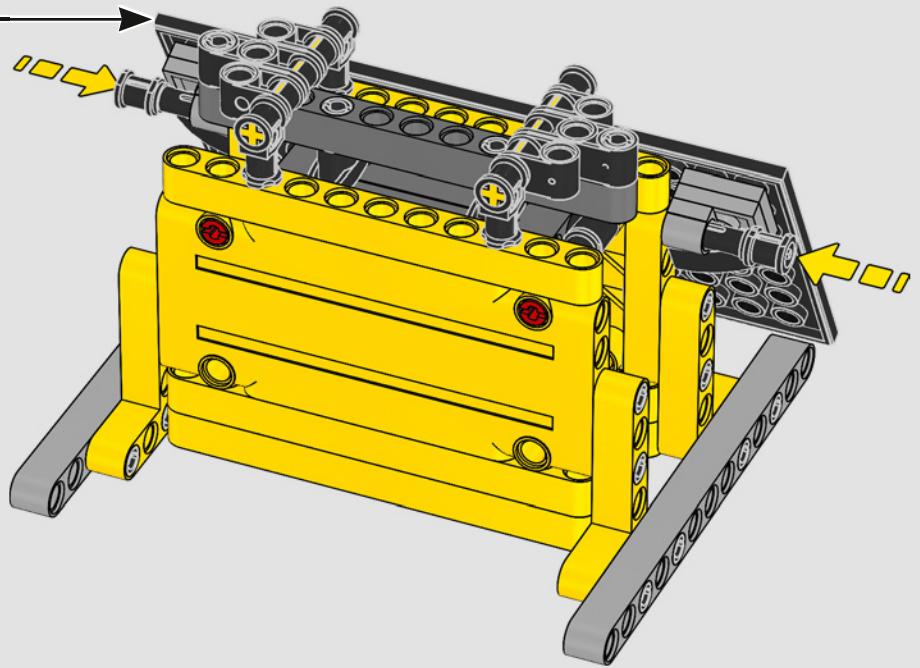

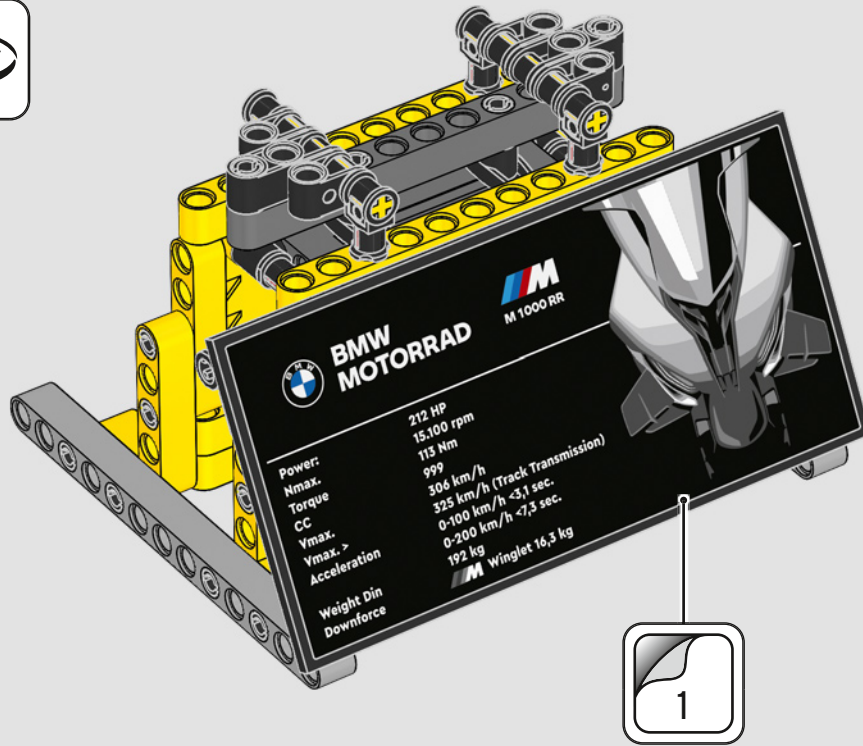

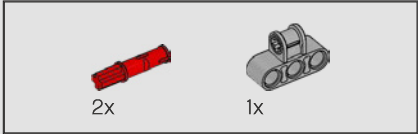
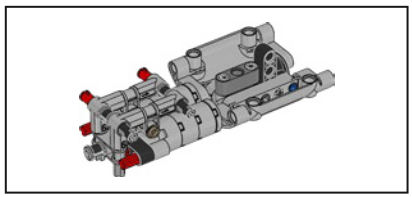

190

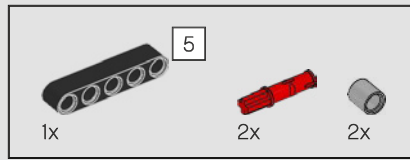
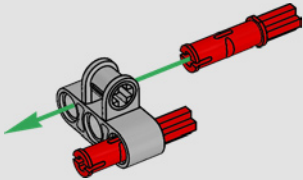

191

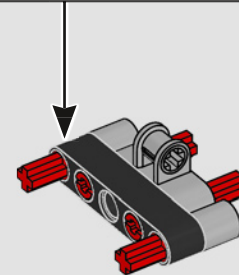
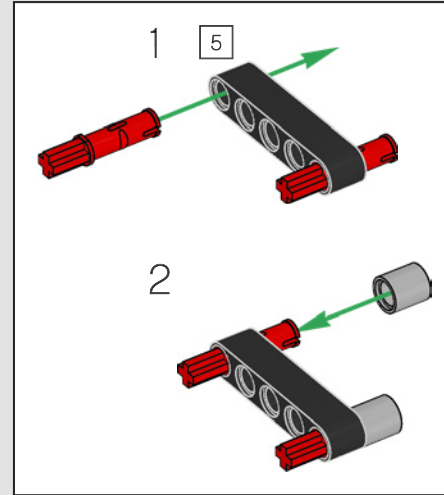

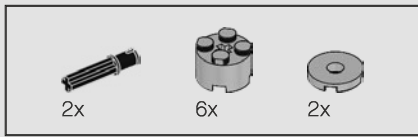

192

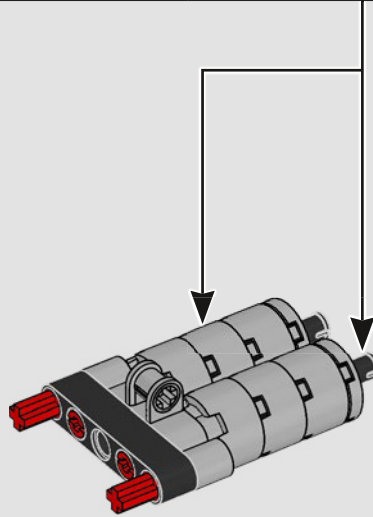
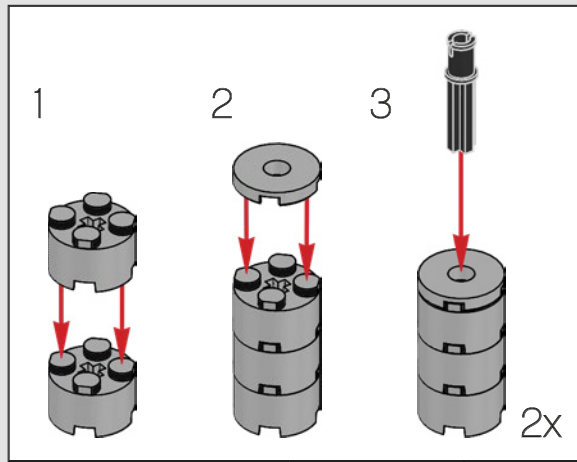

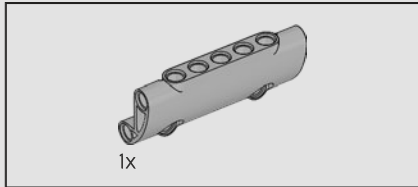
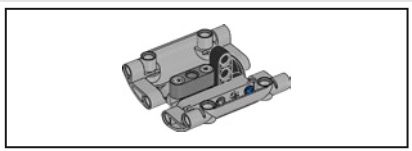

193

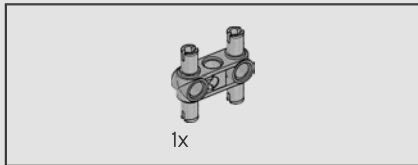
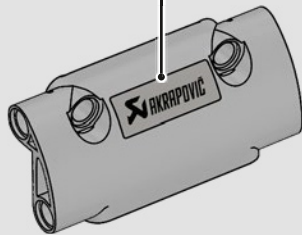

194

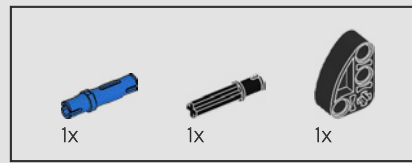
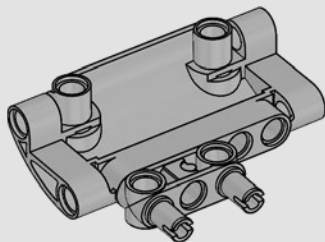

195

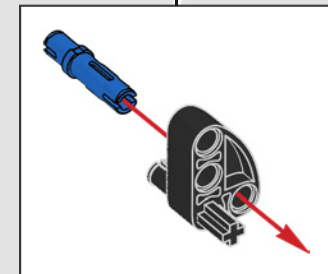
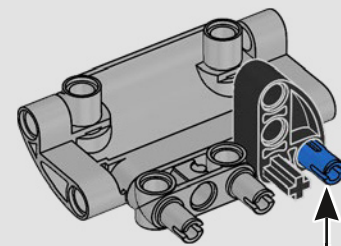

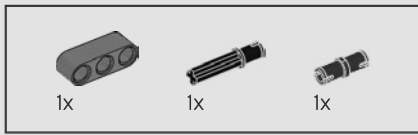

196

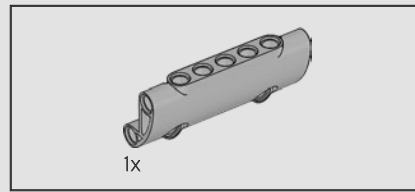
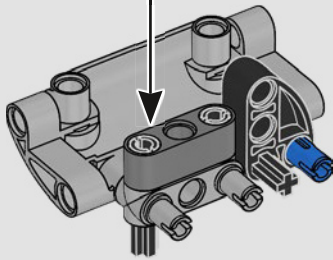
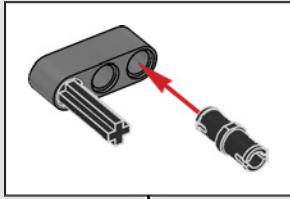

197

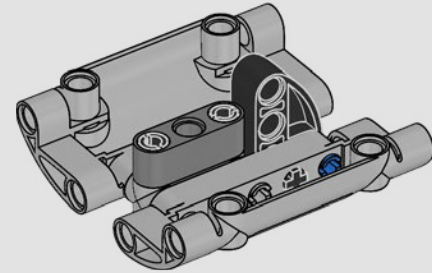
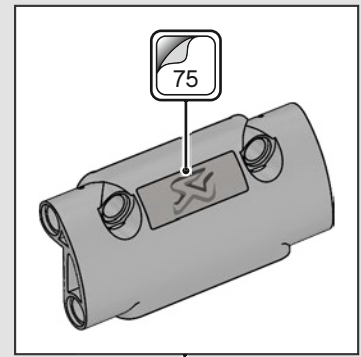

198

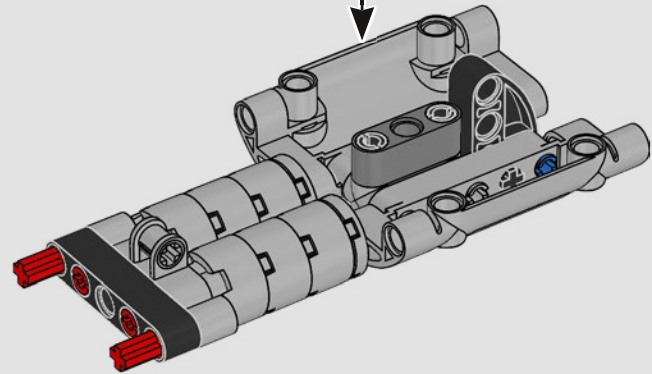

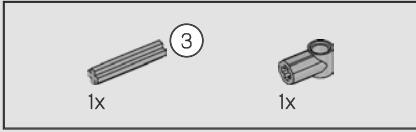
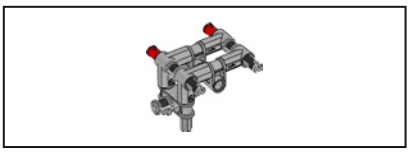

199

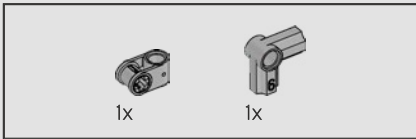
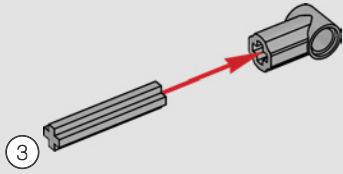

200

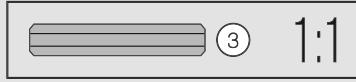
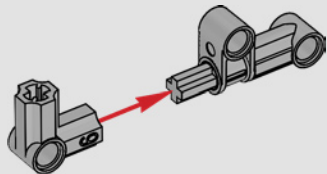

201

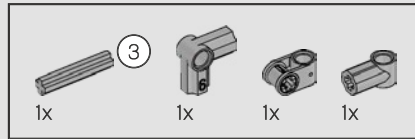
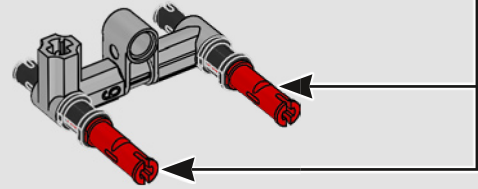
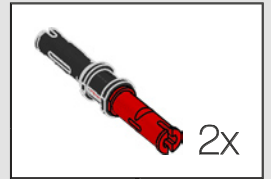

202

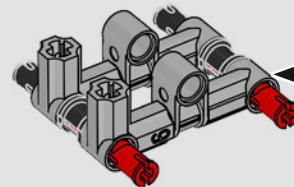
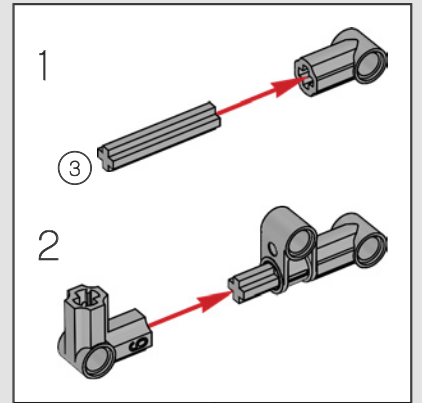

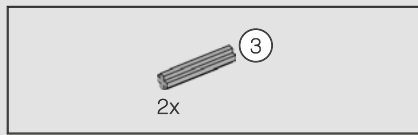

203

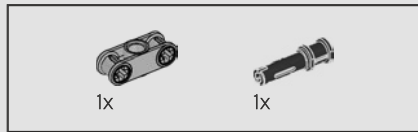
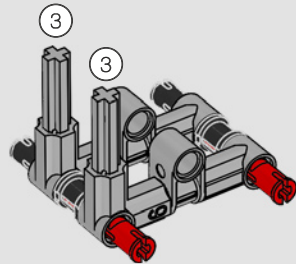

204

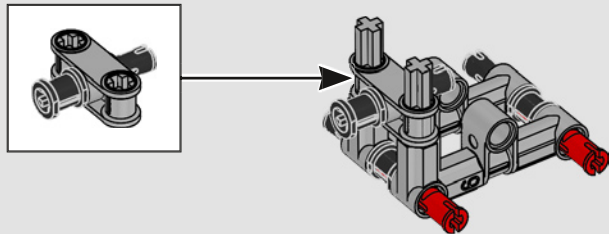

205

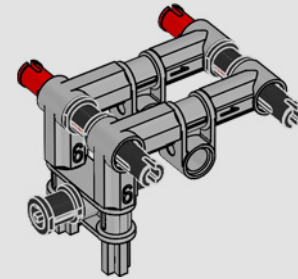

206

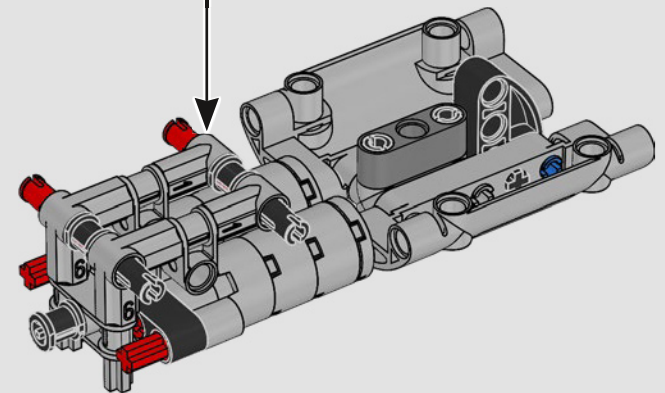

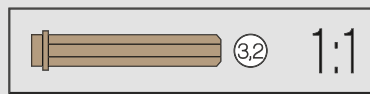
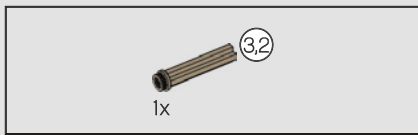

207

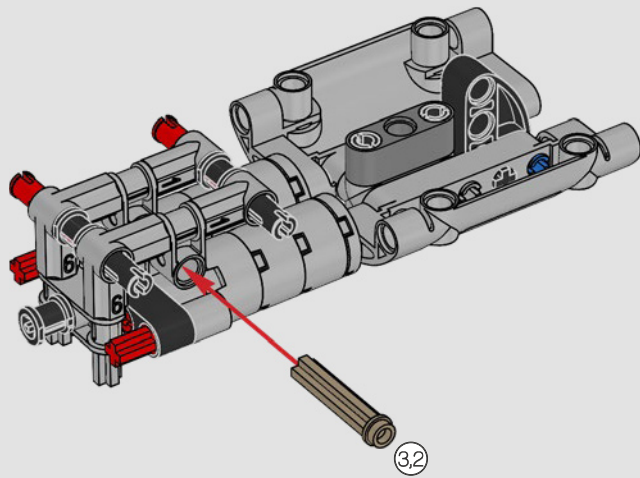

208

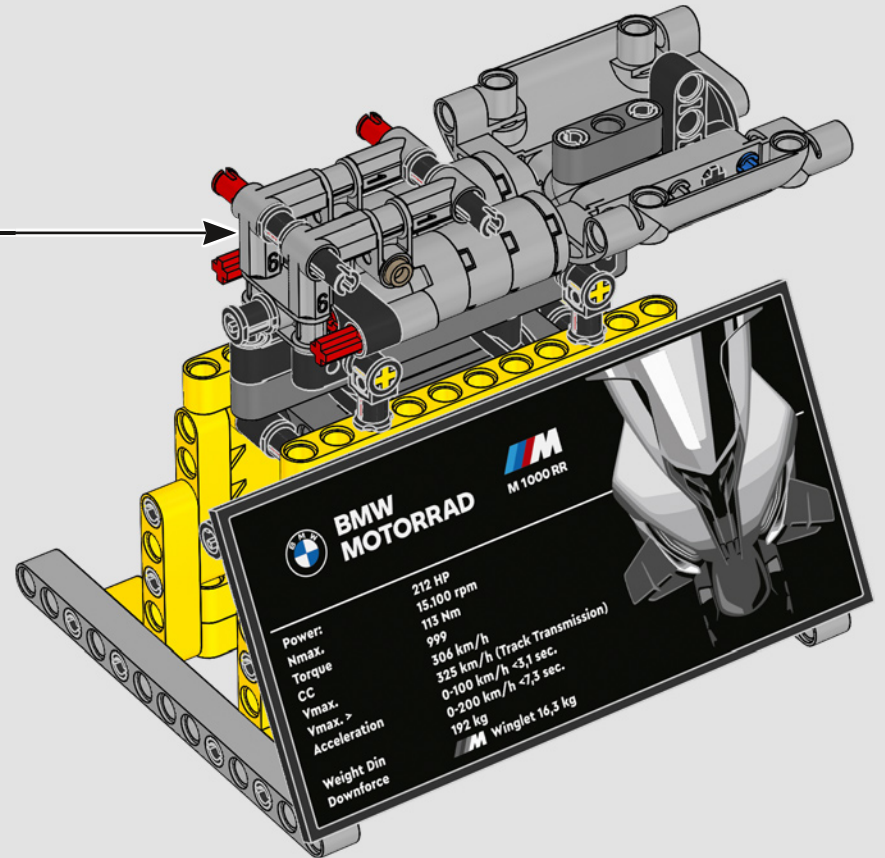

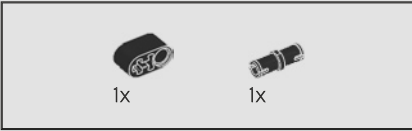
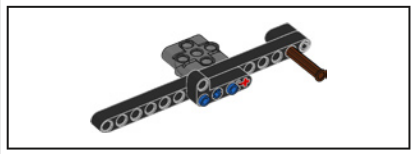

209

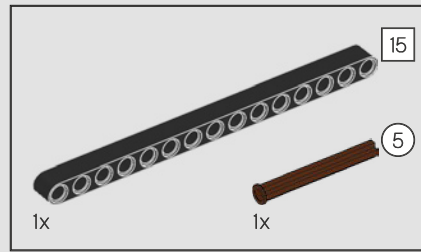
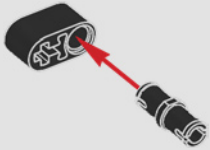

210

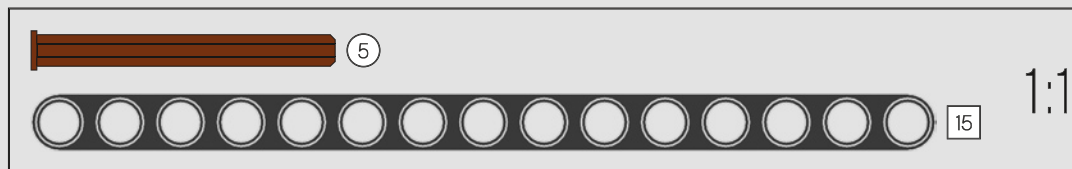
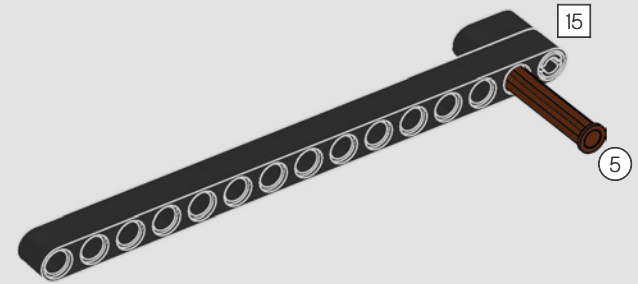

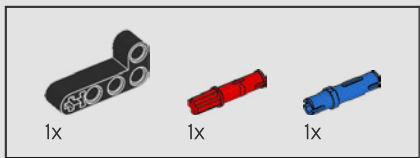

211

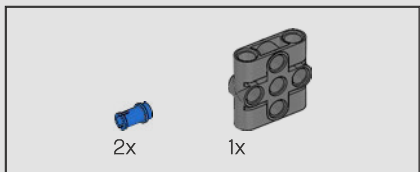
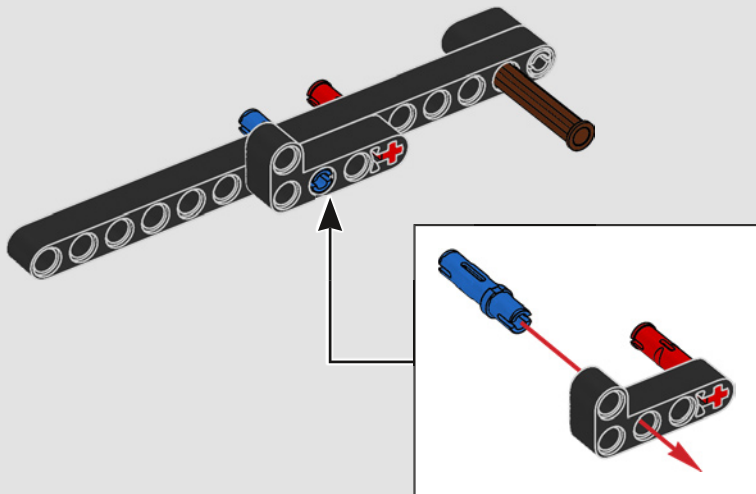

212

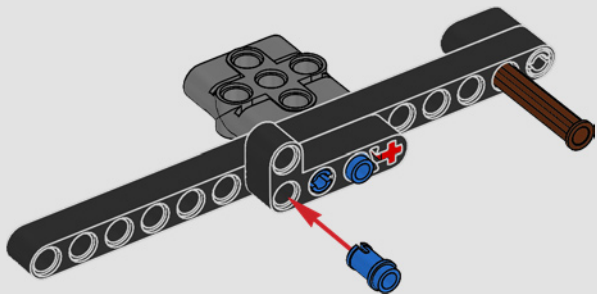

213

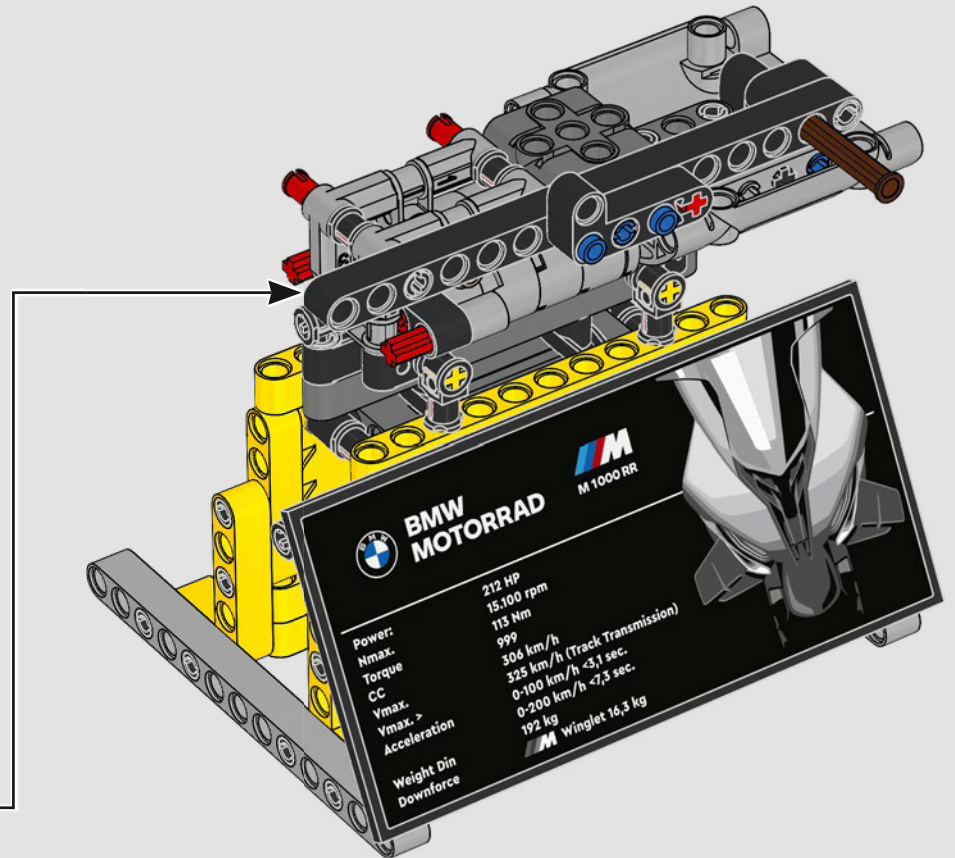

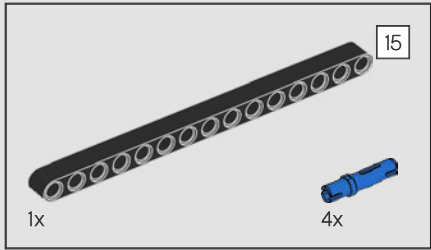
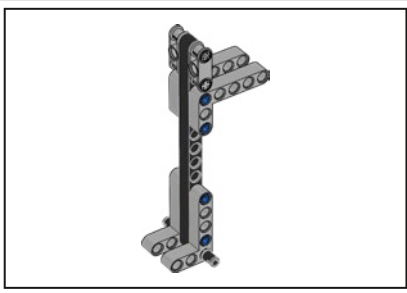

214

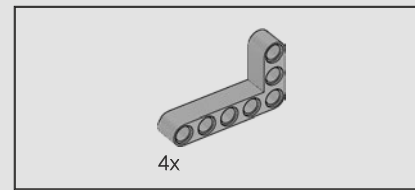
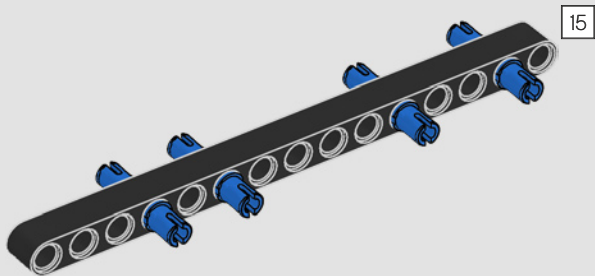

215

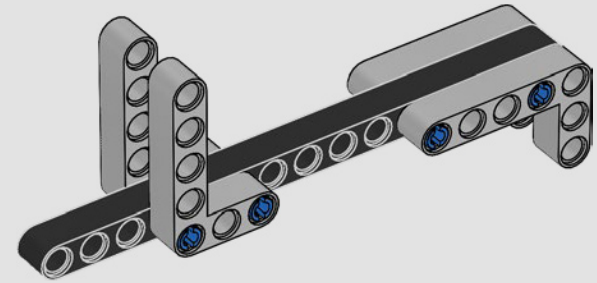

216

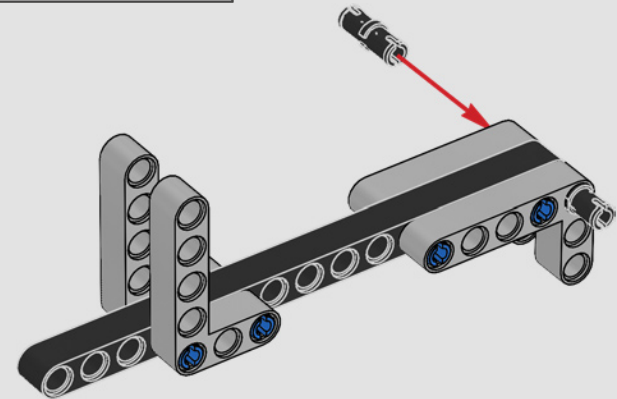

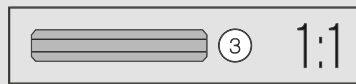
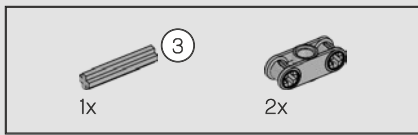

217

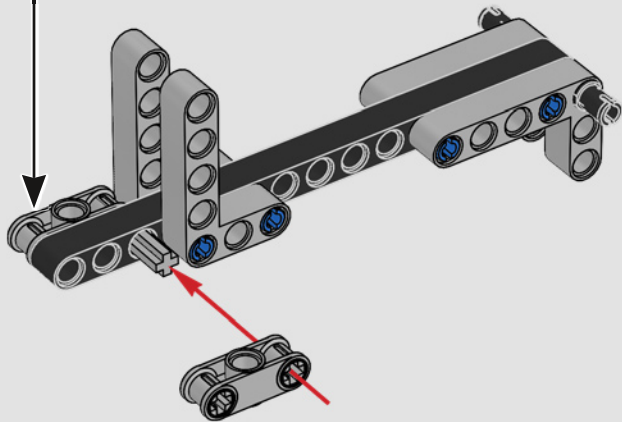
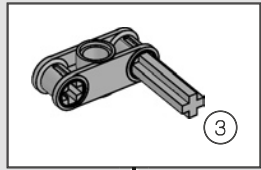

218

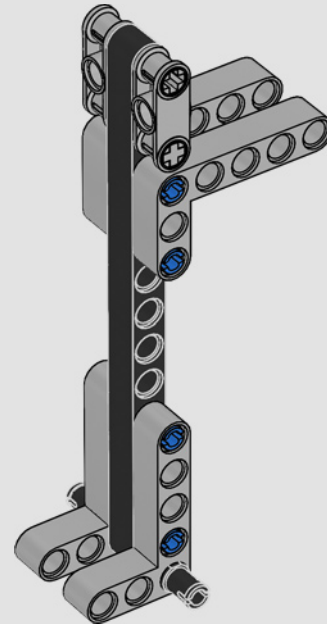
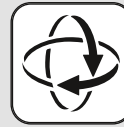

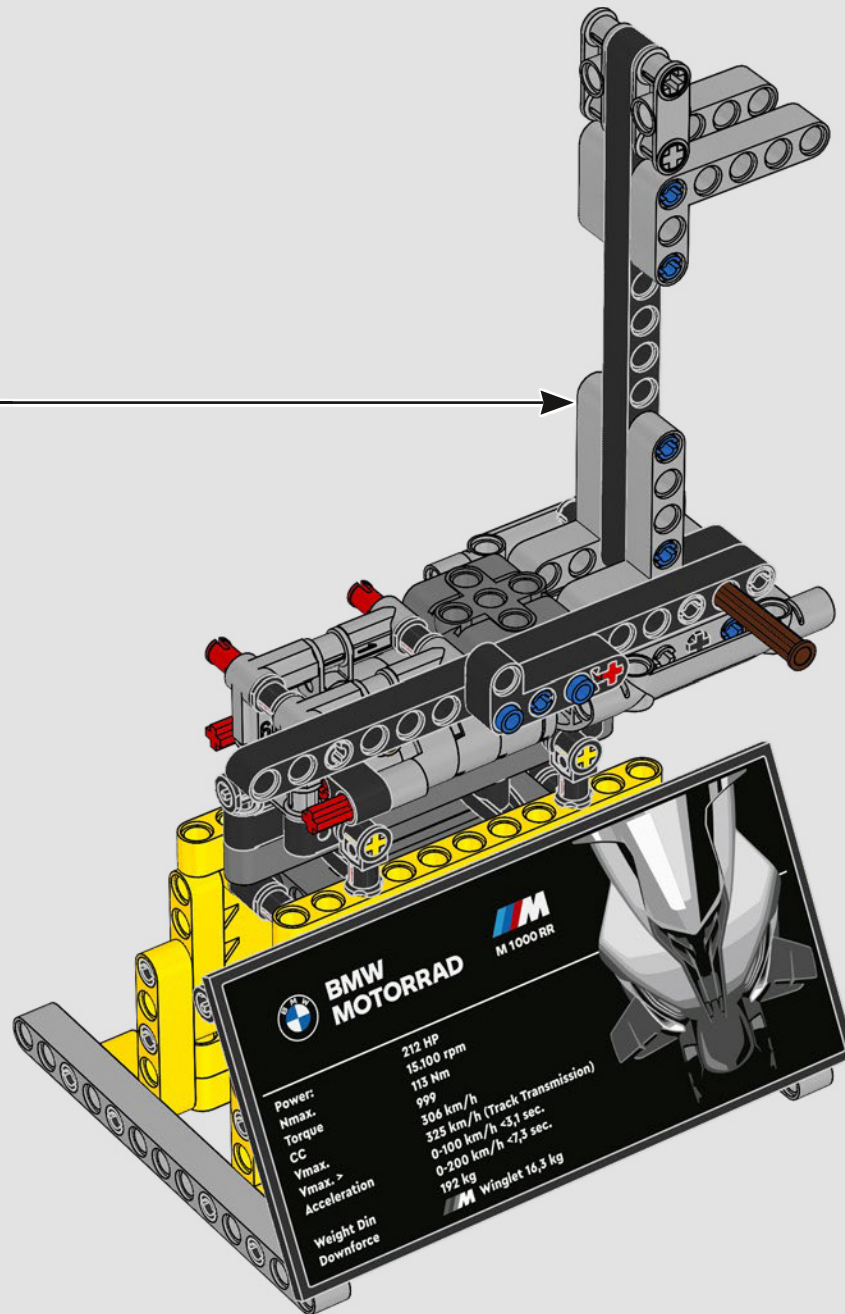

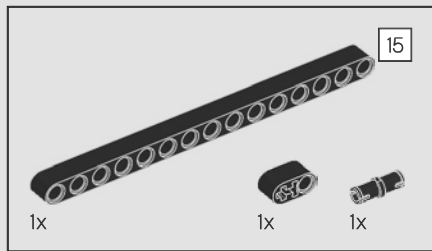

220

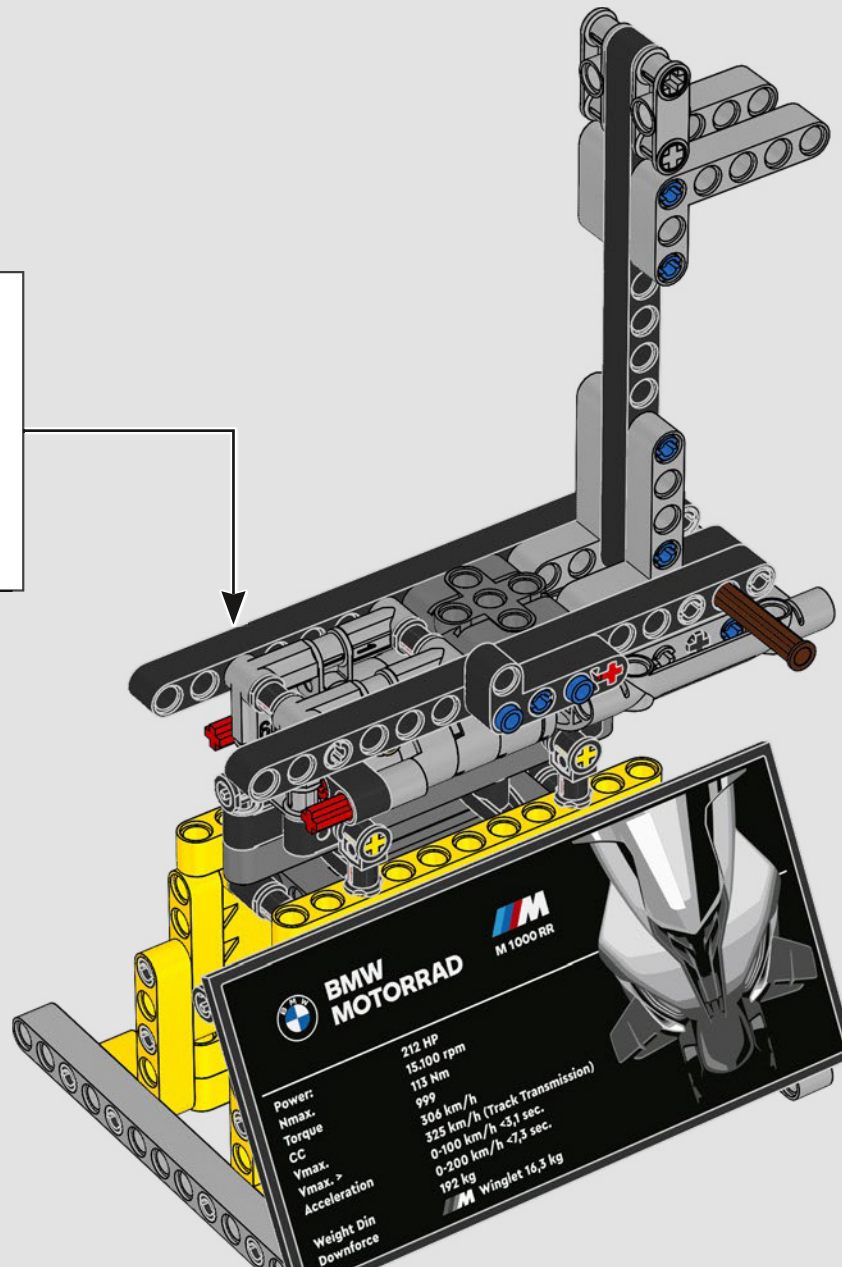
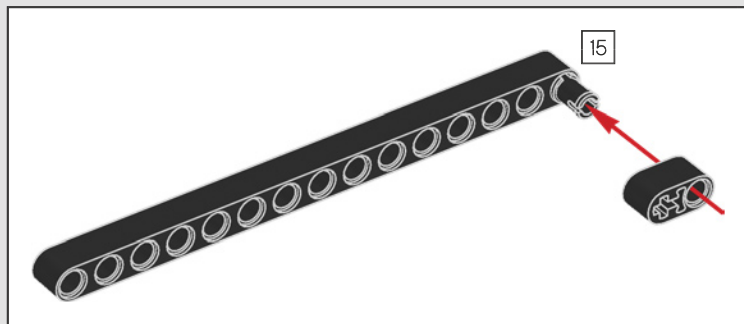

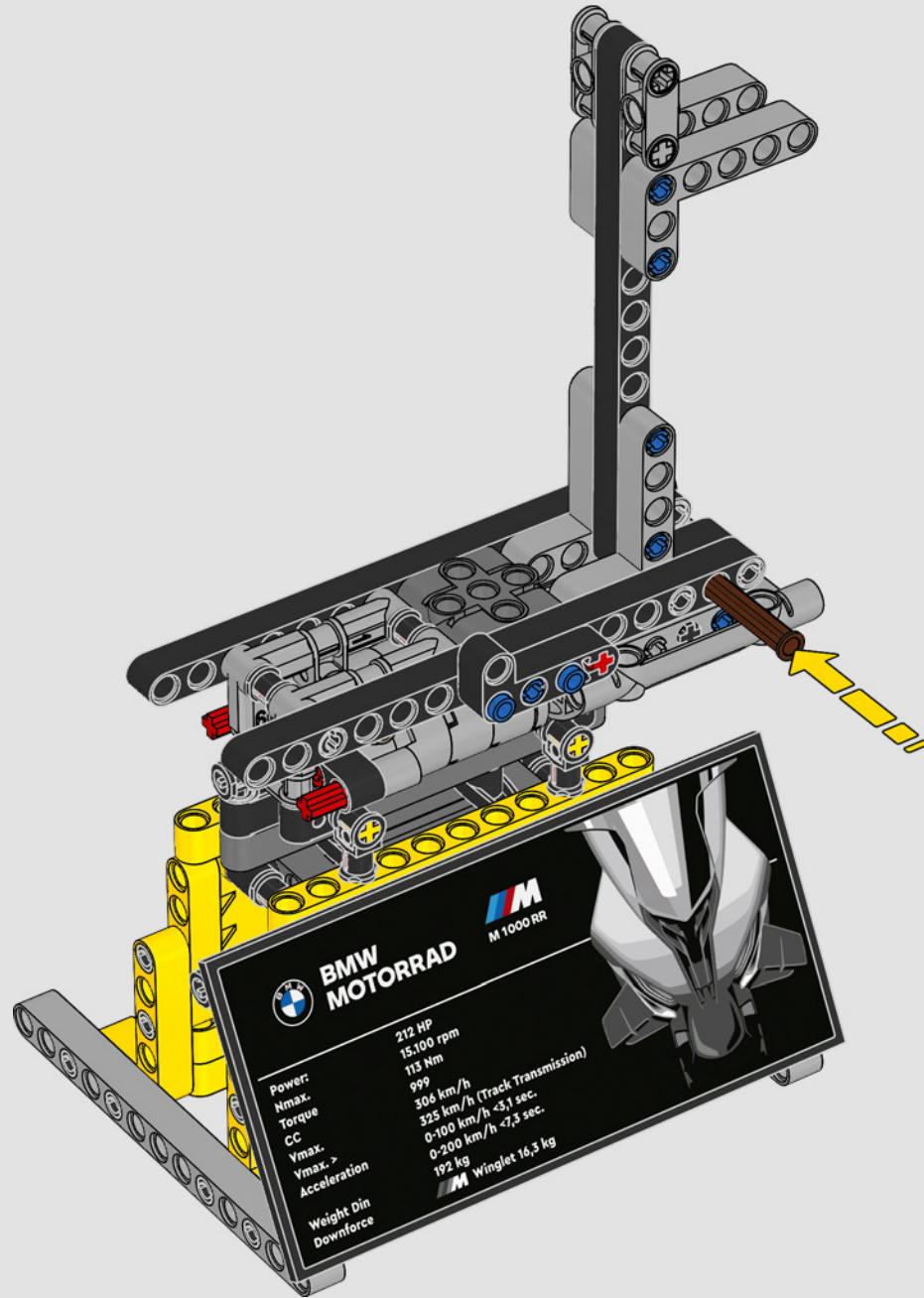

221

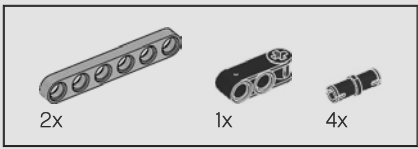

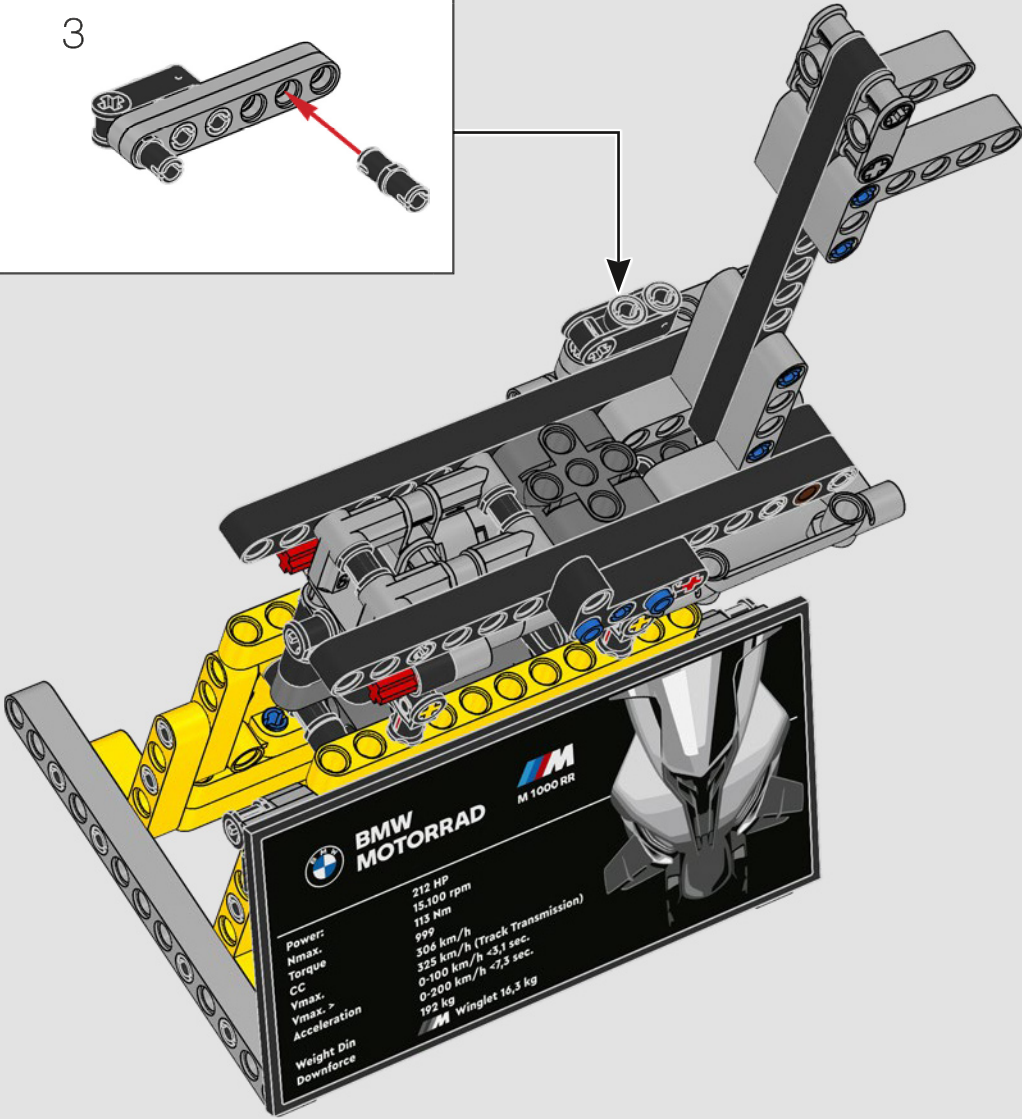
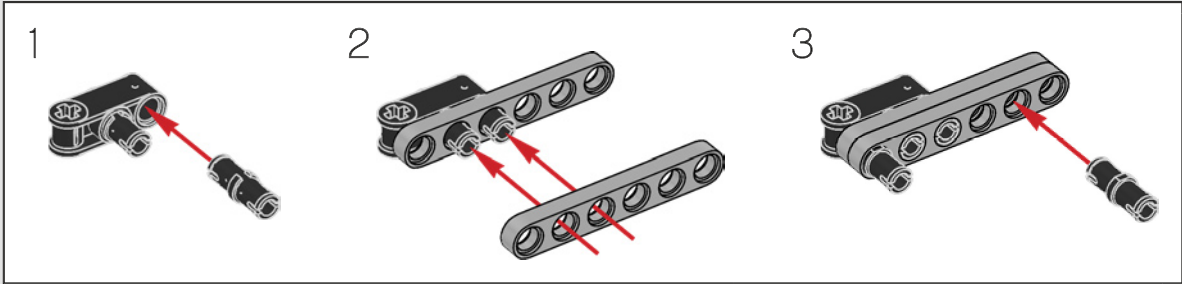

222



BMW MOTORRAD  M 1000 RR

Power:	212 HP
Nmax:	15,100 rpm
Torque	115 Nm
CC	999
Vmax:	206 km/h
Vmax >	225 km/h (Track Transmission)
Acceleration	0-100 km/h < 3,1 sec.
	0-200 km/h < 7,5 sec.
Weight Din	192 kg
Downforce	 Winglet 16,3 kg

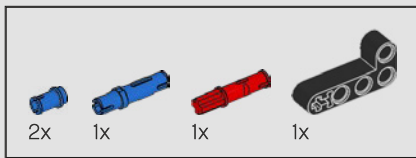

223

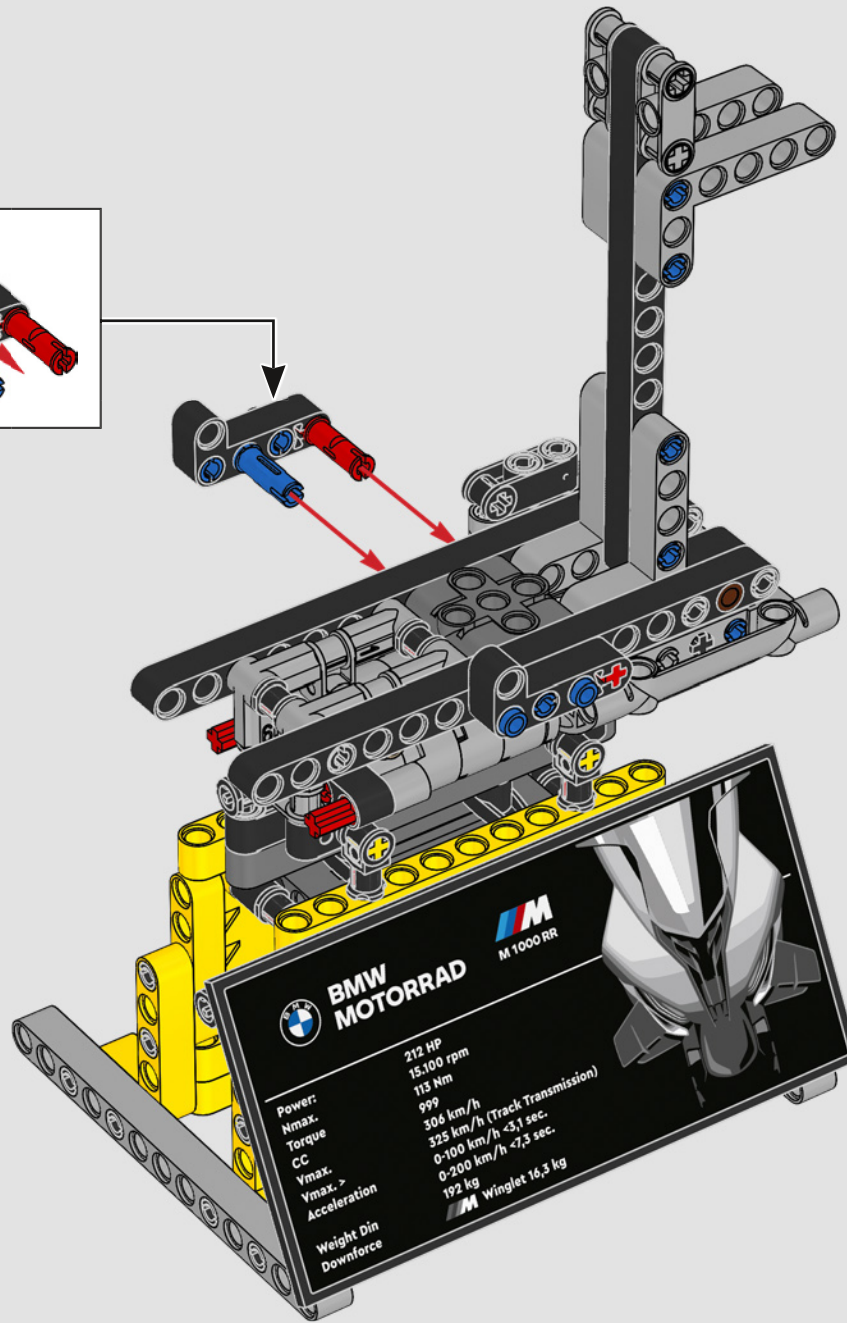
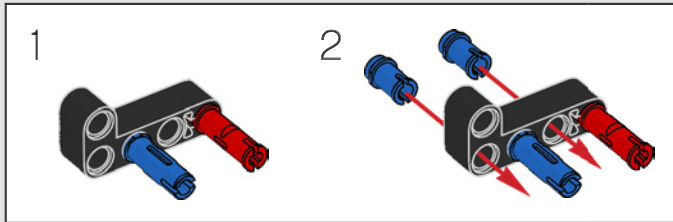

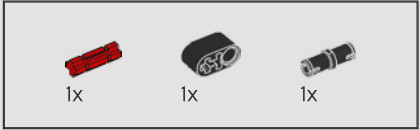
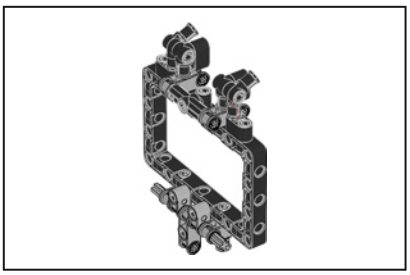

224

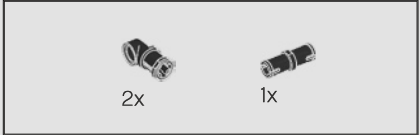
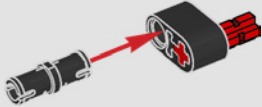

225

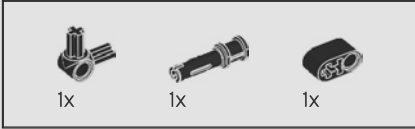
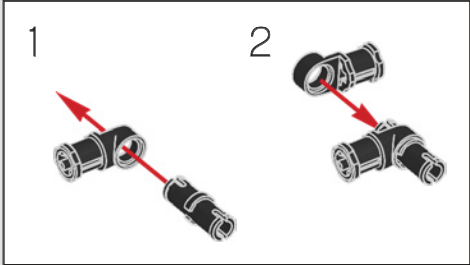

226

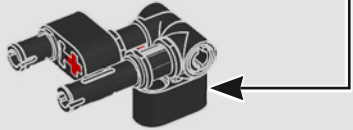
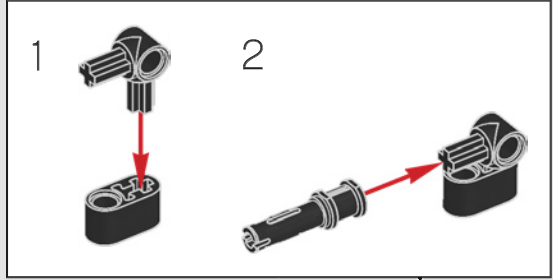

227

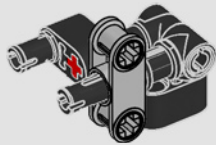

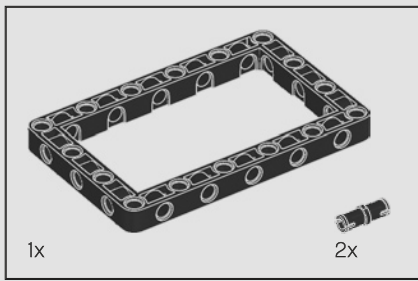

228

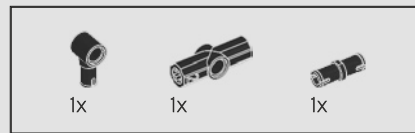
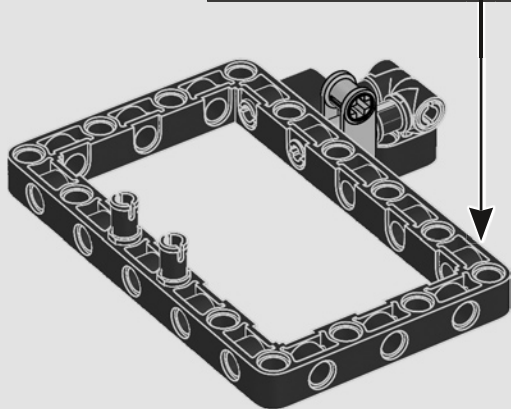
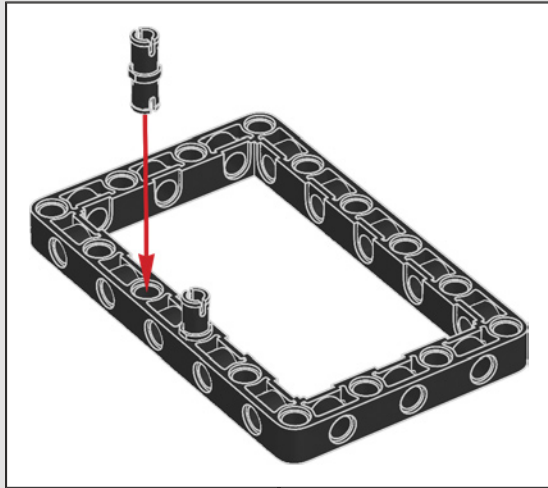

229

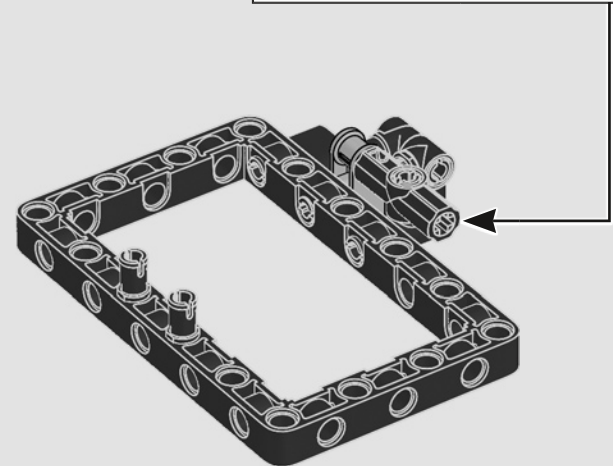
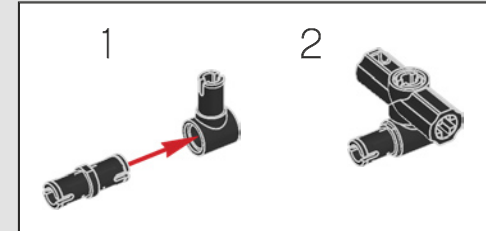



230

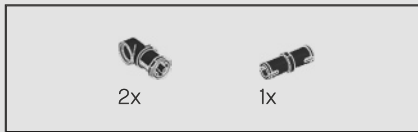

231

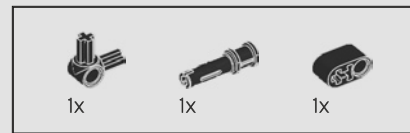
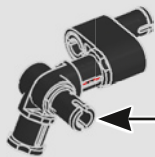
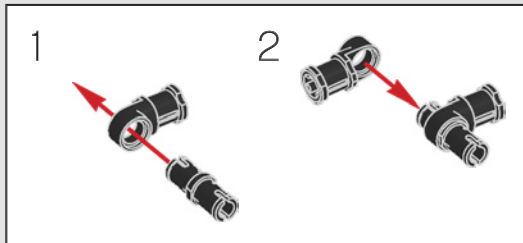

232

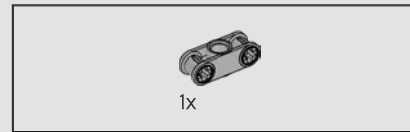
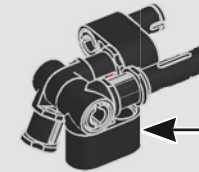
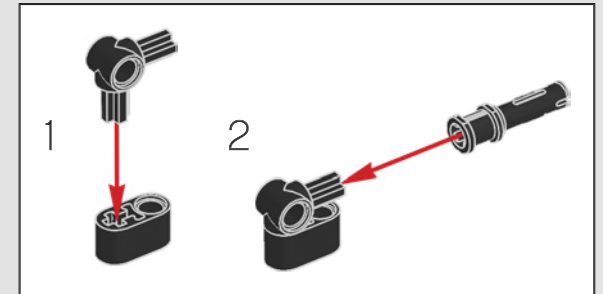

233

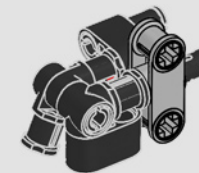

234

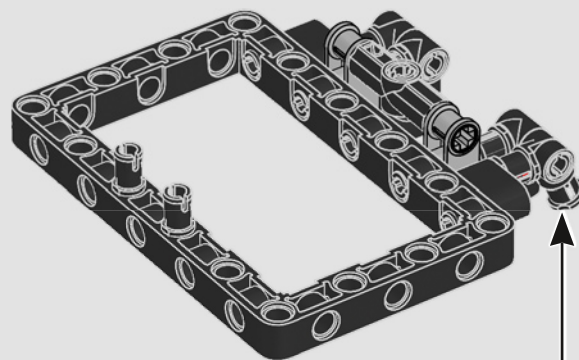

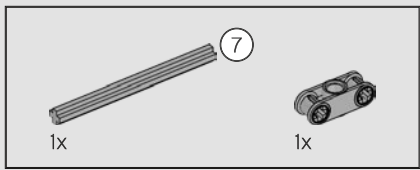

235

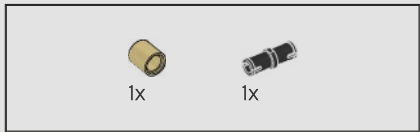
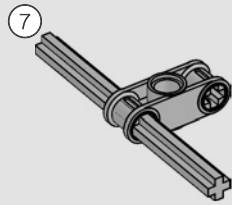

236

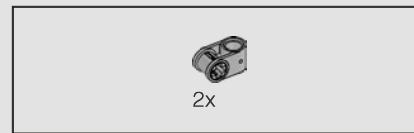
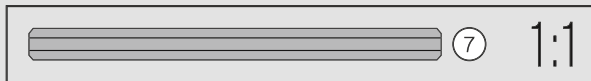
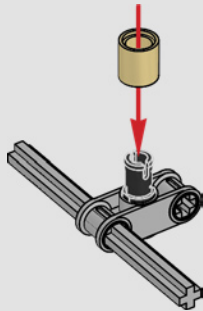

237

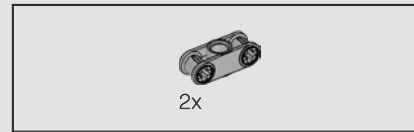
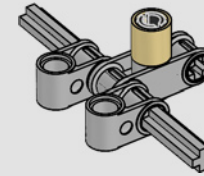

238

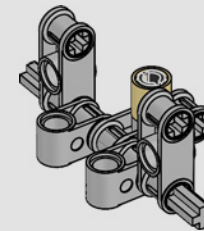

239

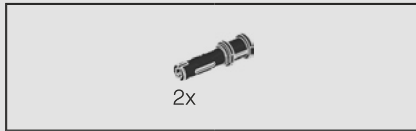
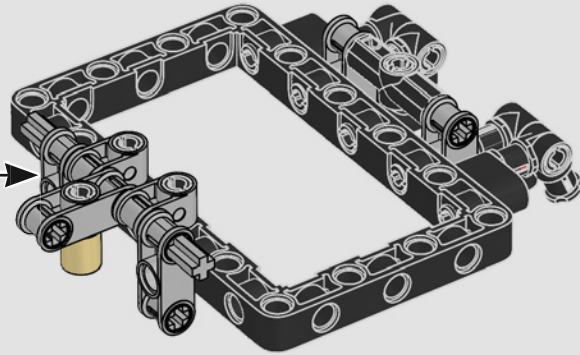

240

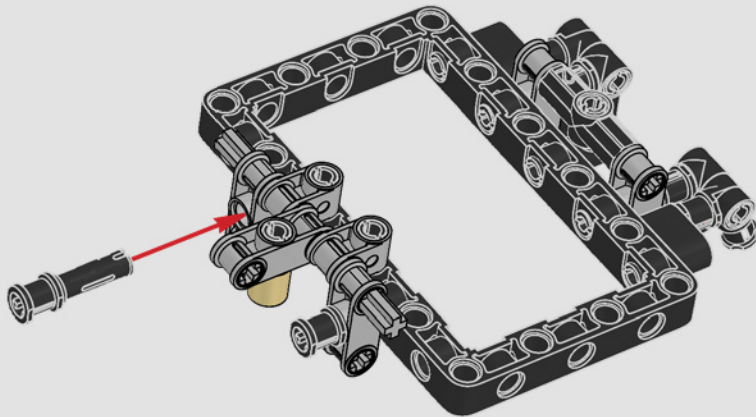

241

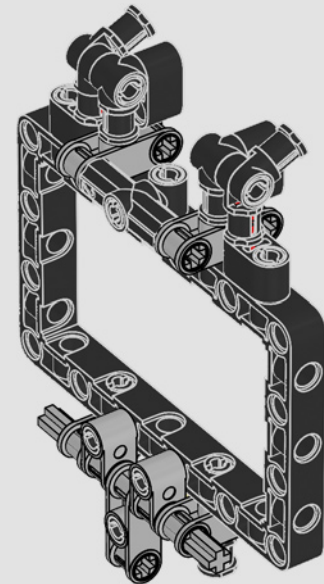

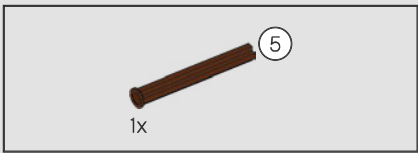

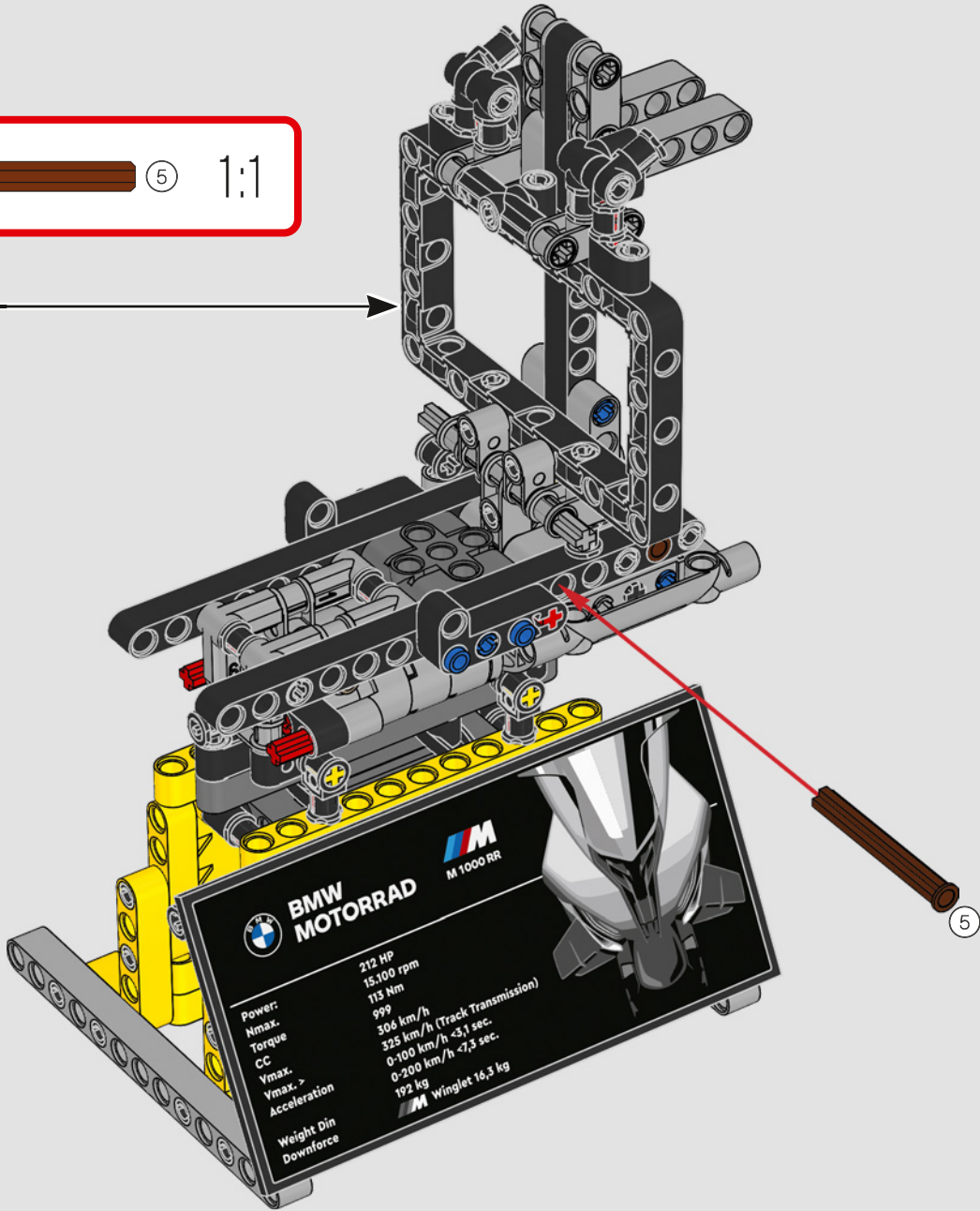
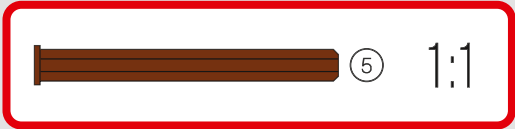

242

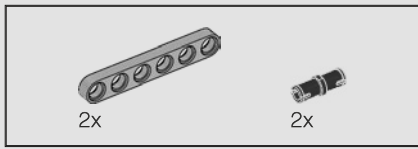

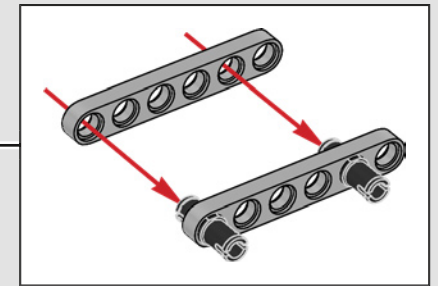
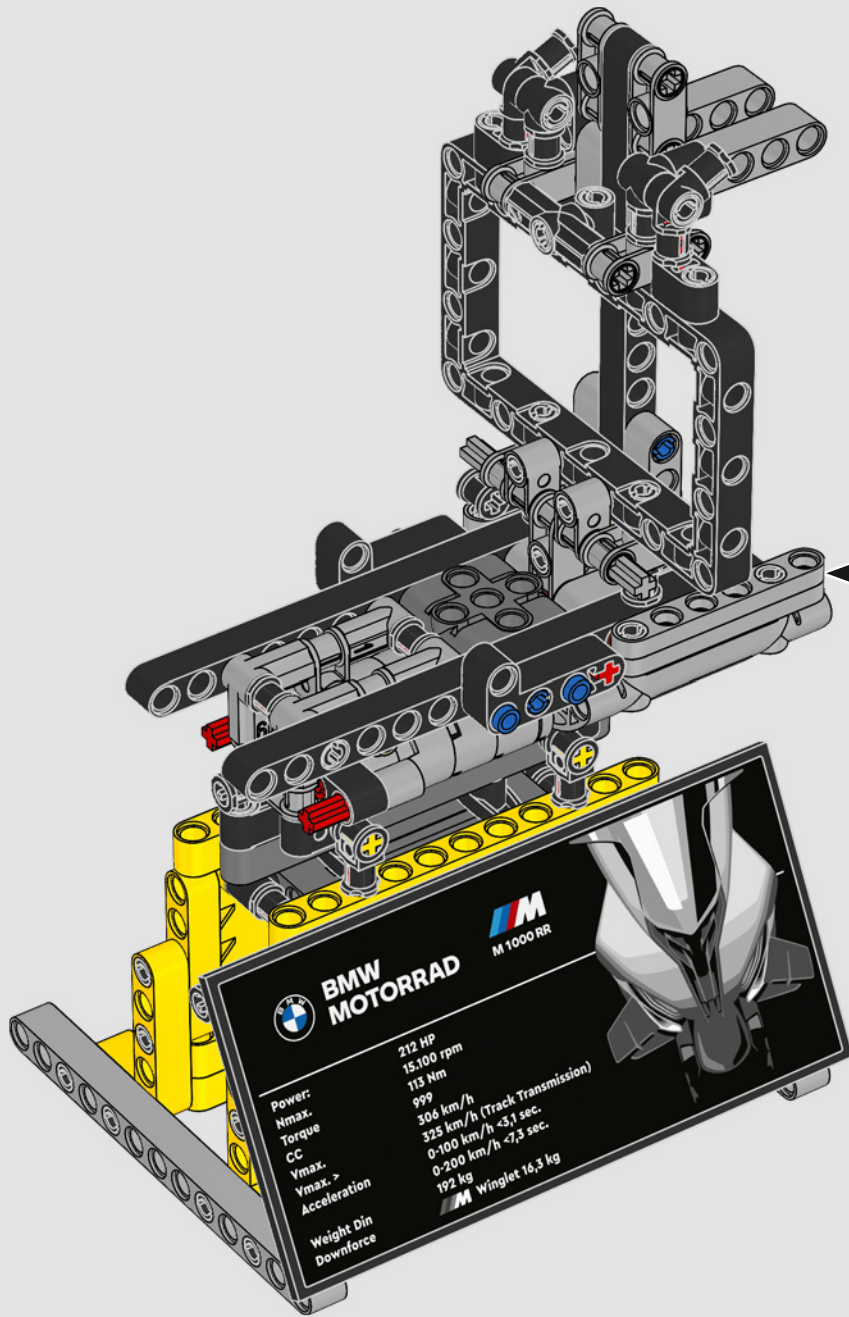

243



BMW MOTORRAD  

Power:	212 HP
Nmax.	15.100 rpm
Torque	113 Nm
CC	999
Vmax.	306 km/h
Acceleration	325 km/h (Track Transmission) 0-100 km/h <3,1 sec. 0-200 km/h <7,3 sec.
Weight Din	192 kg
Downforce	Winglet 16,3 kg

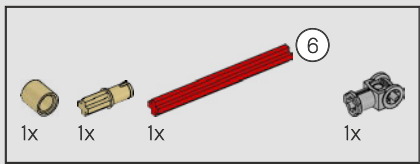

244

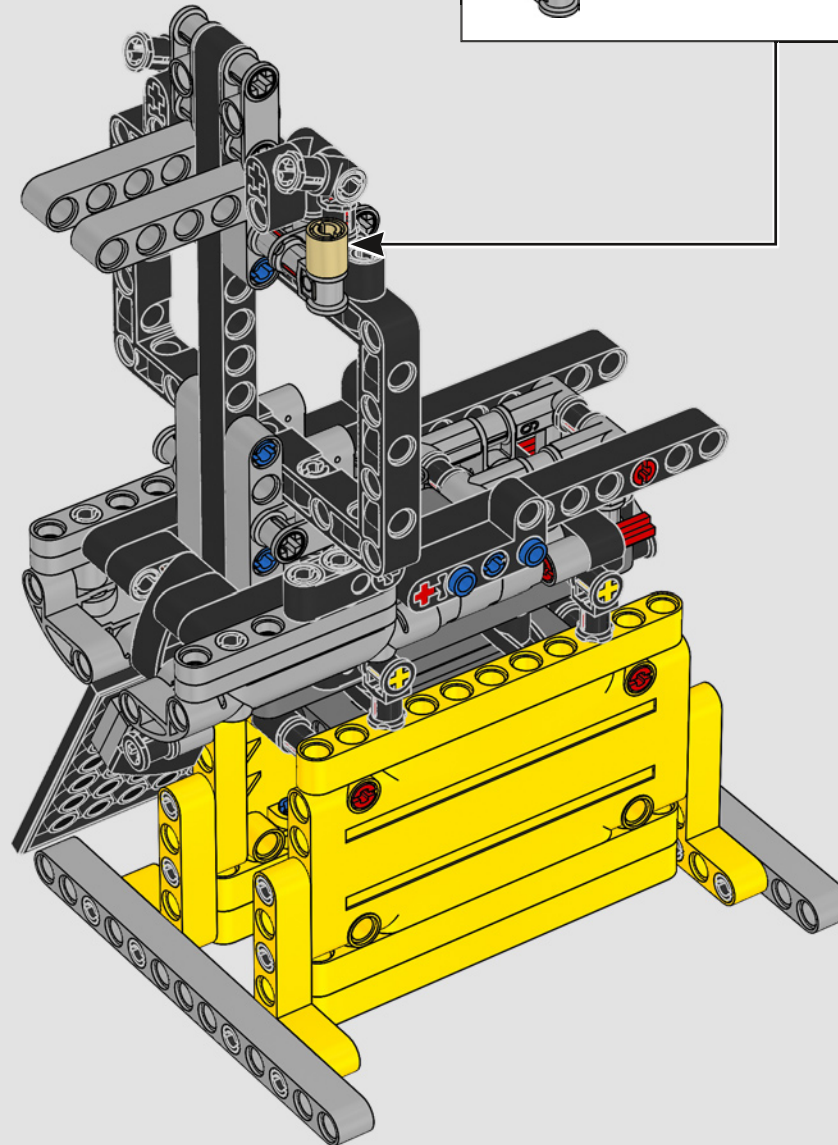
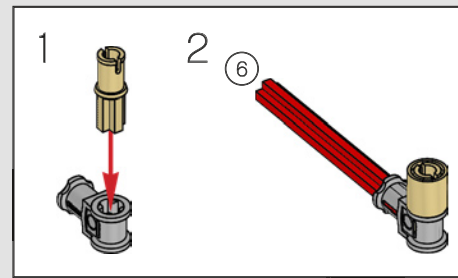

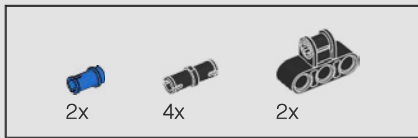

245

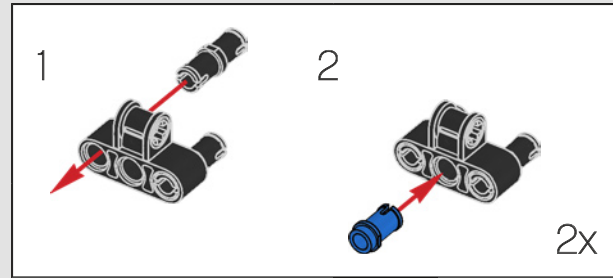
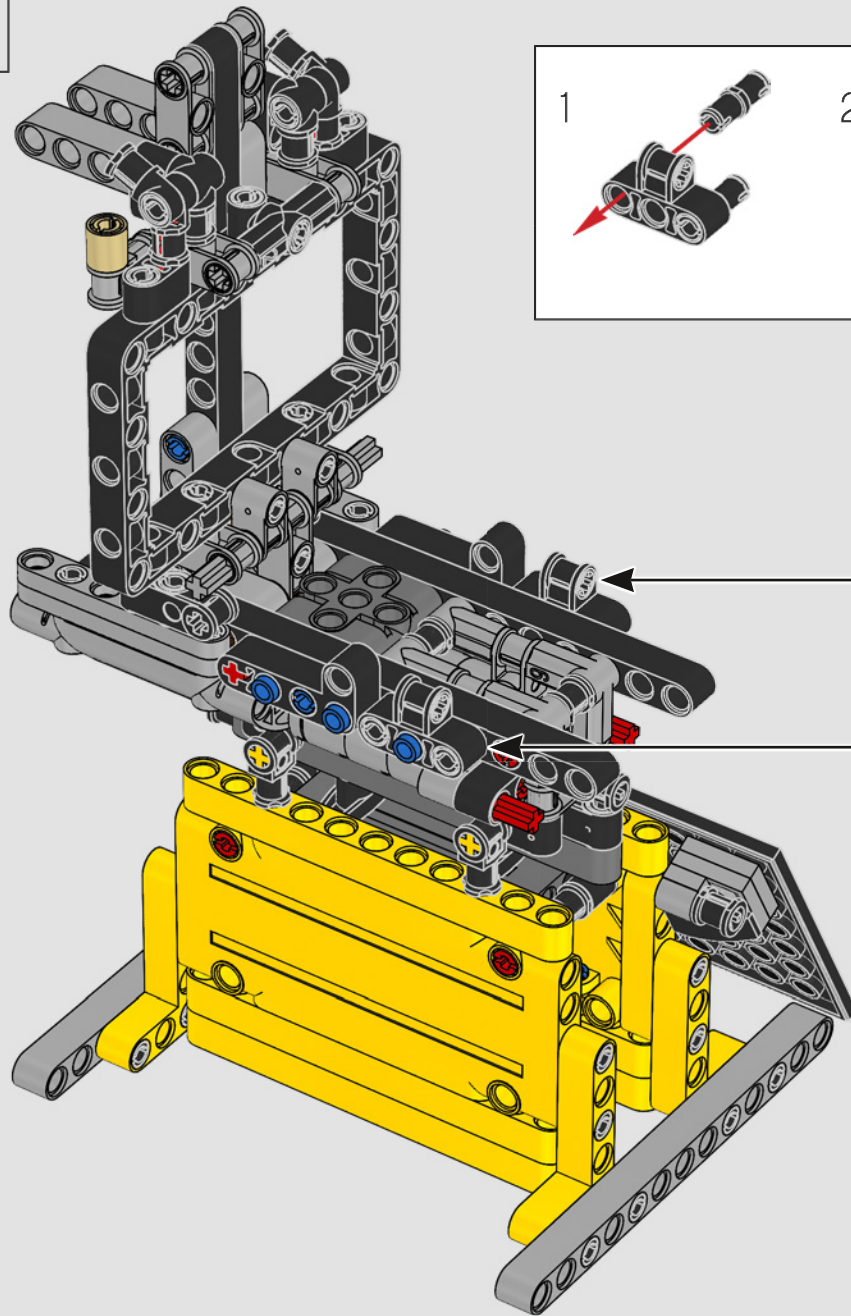

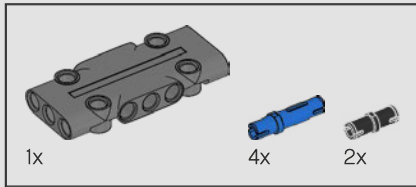
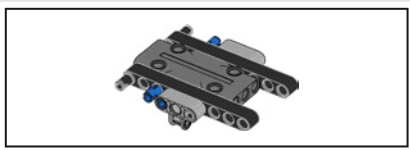

246

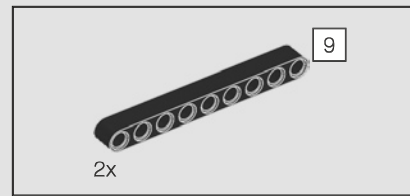
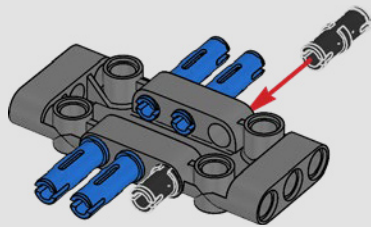

247

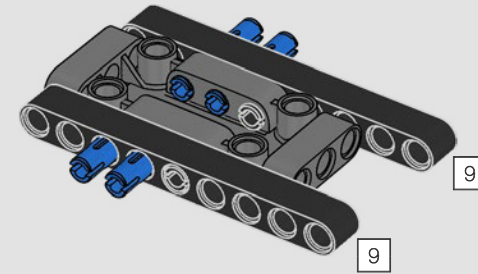

248

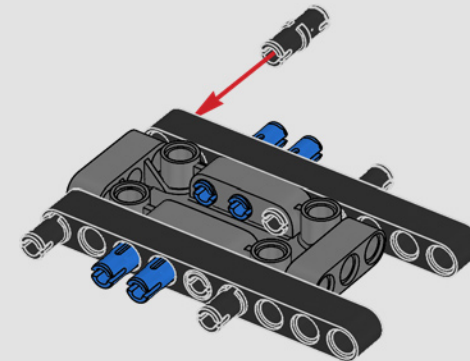

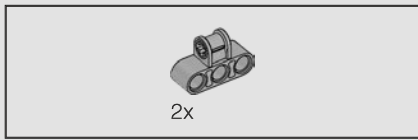

249

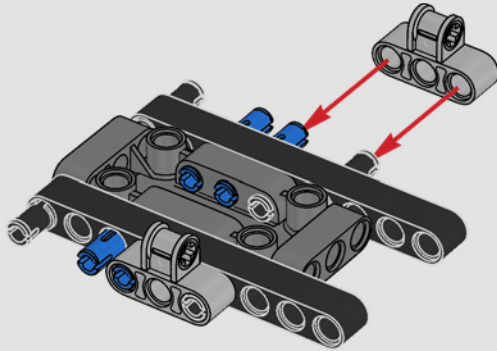

250

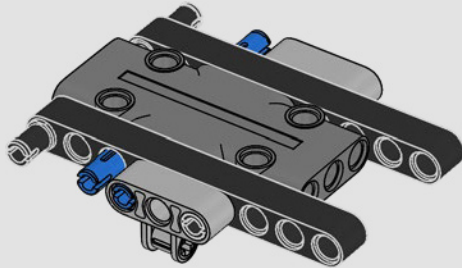

251

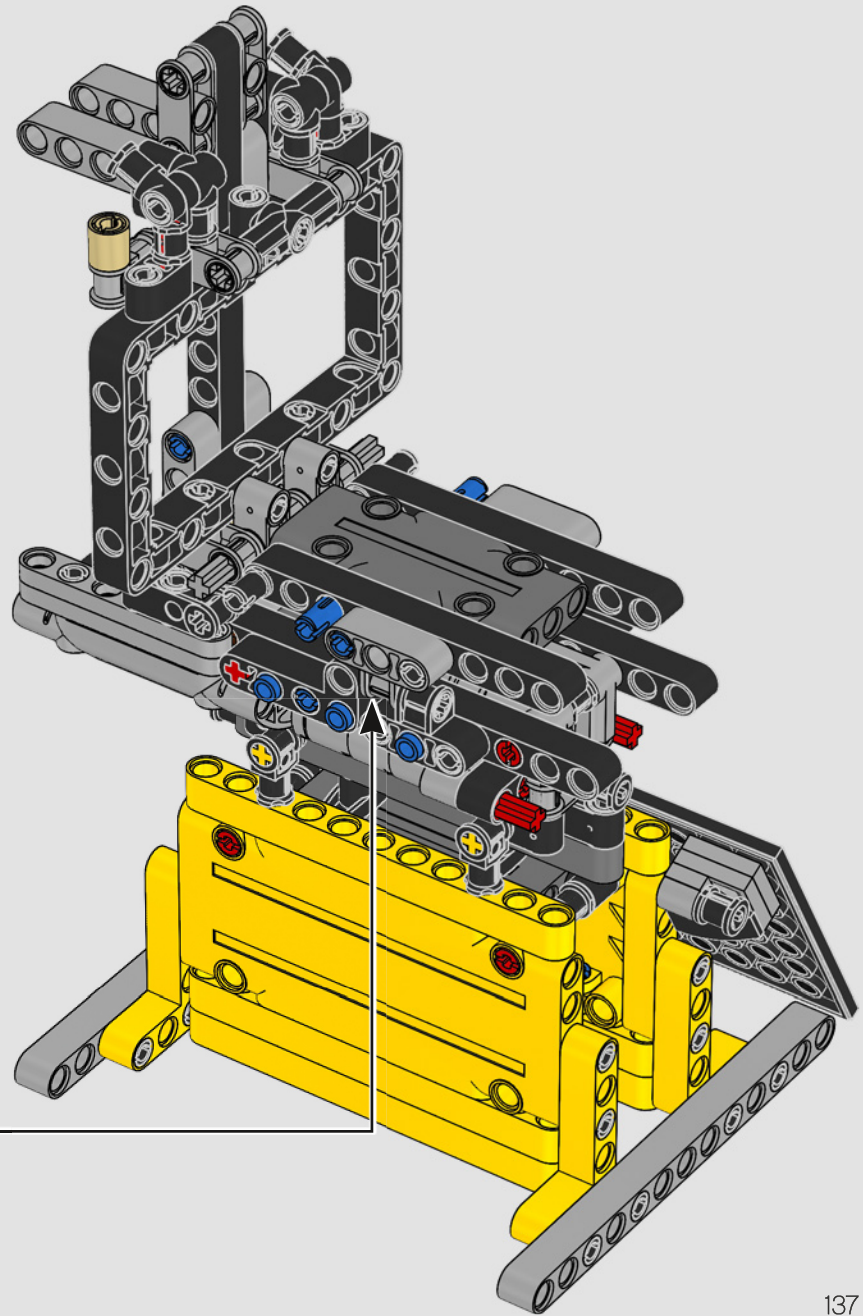

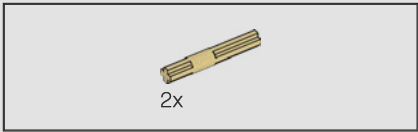

252

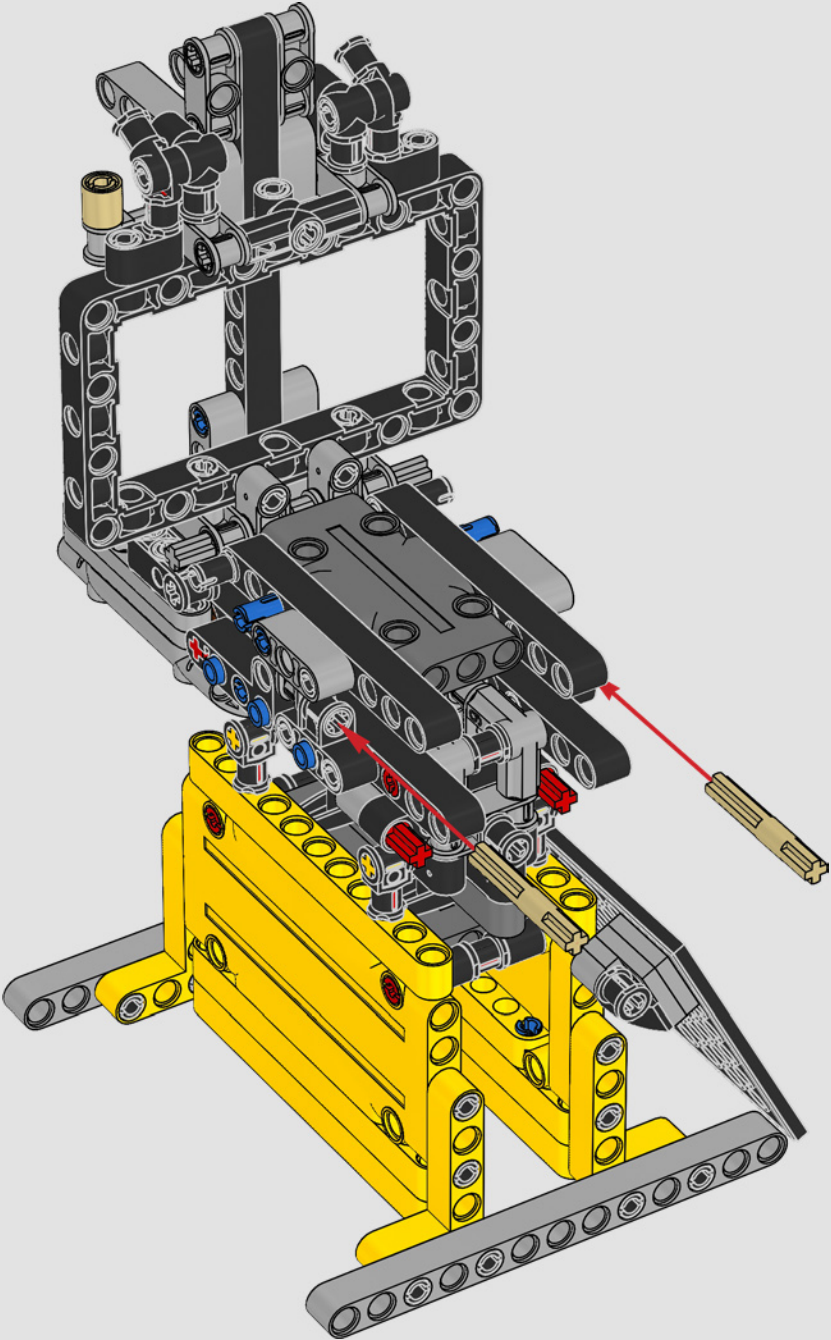

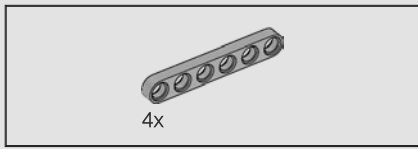

253

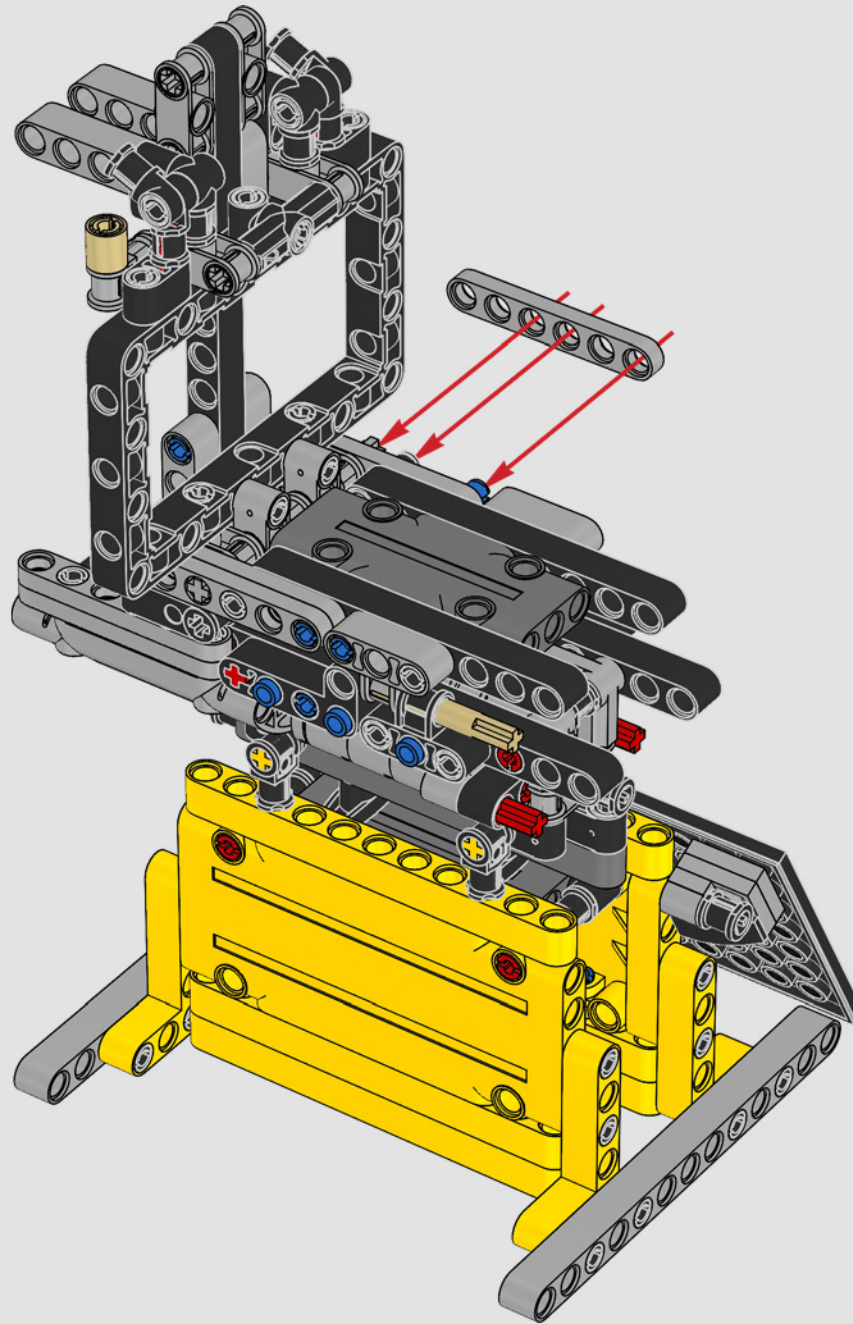

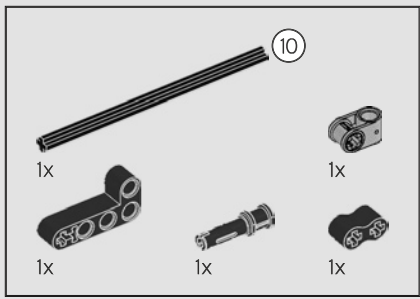

254

1

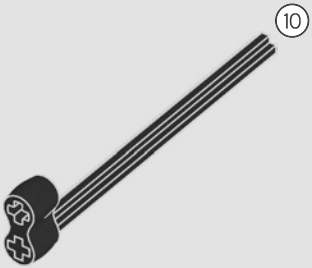

2

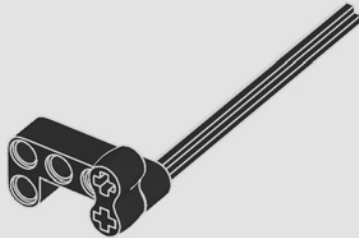

3

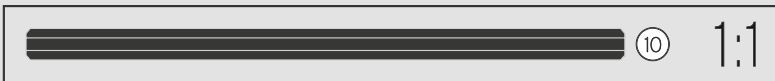
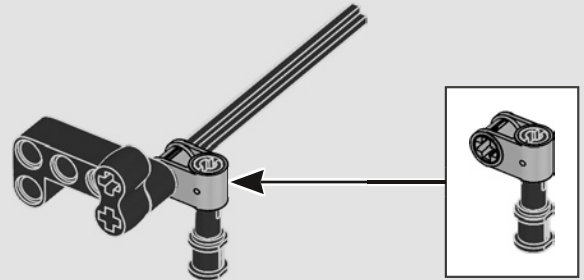

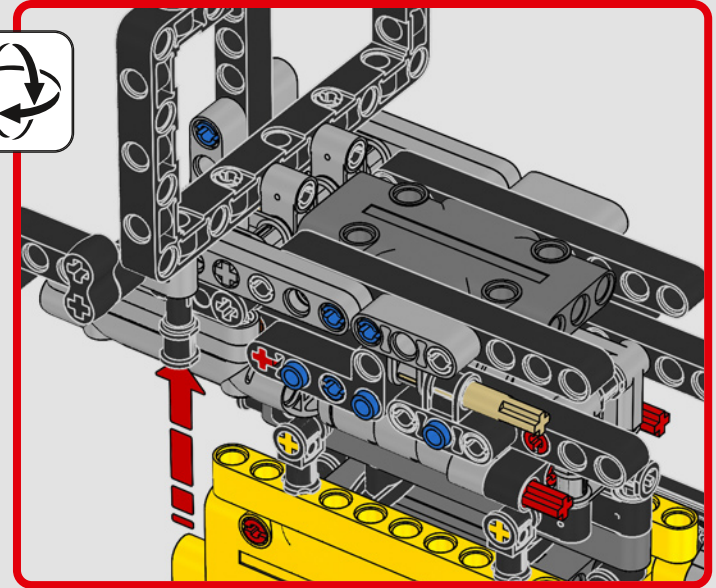
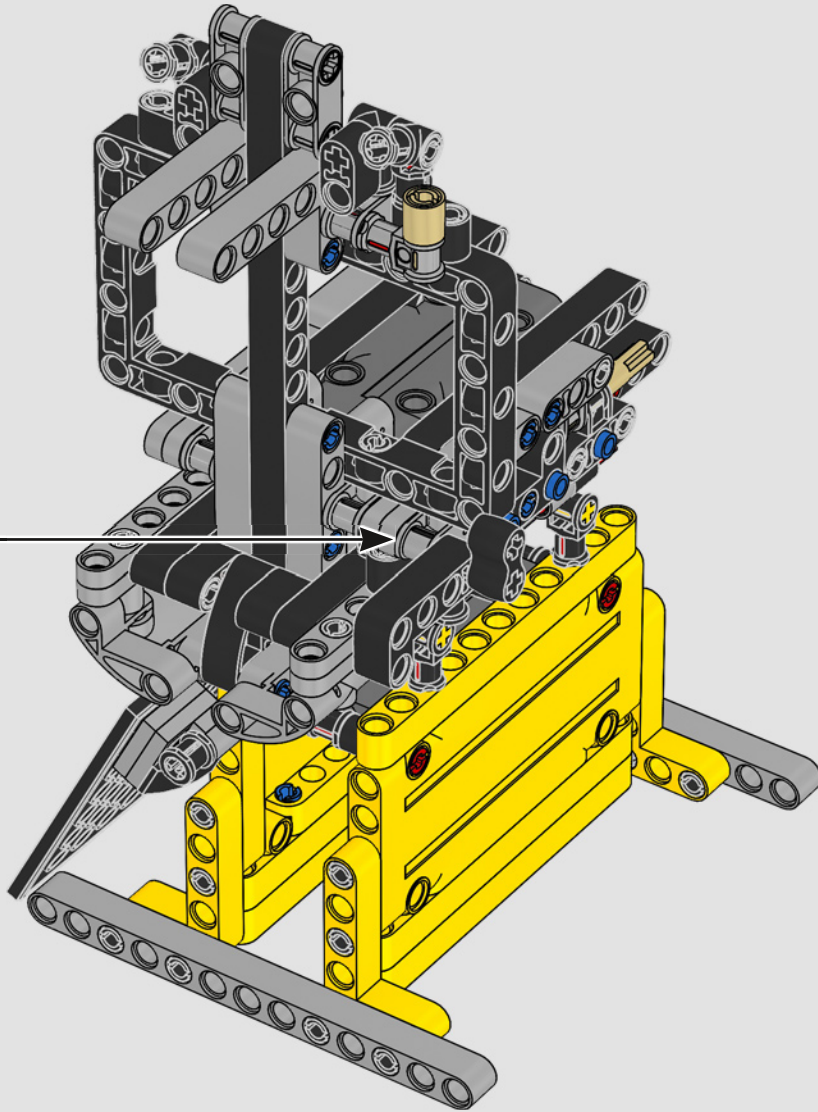

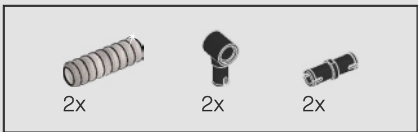

255

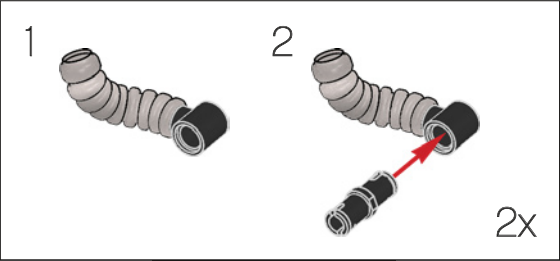
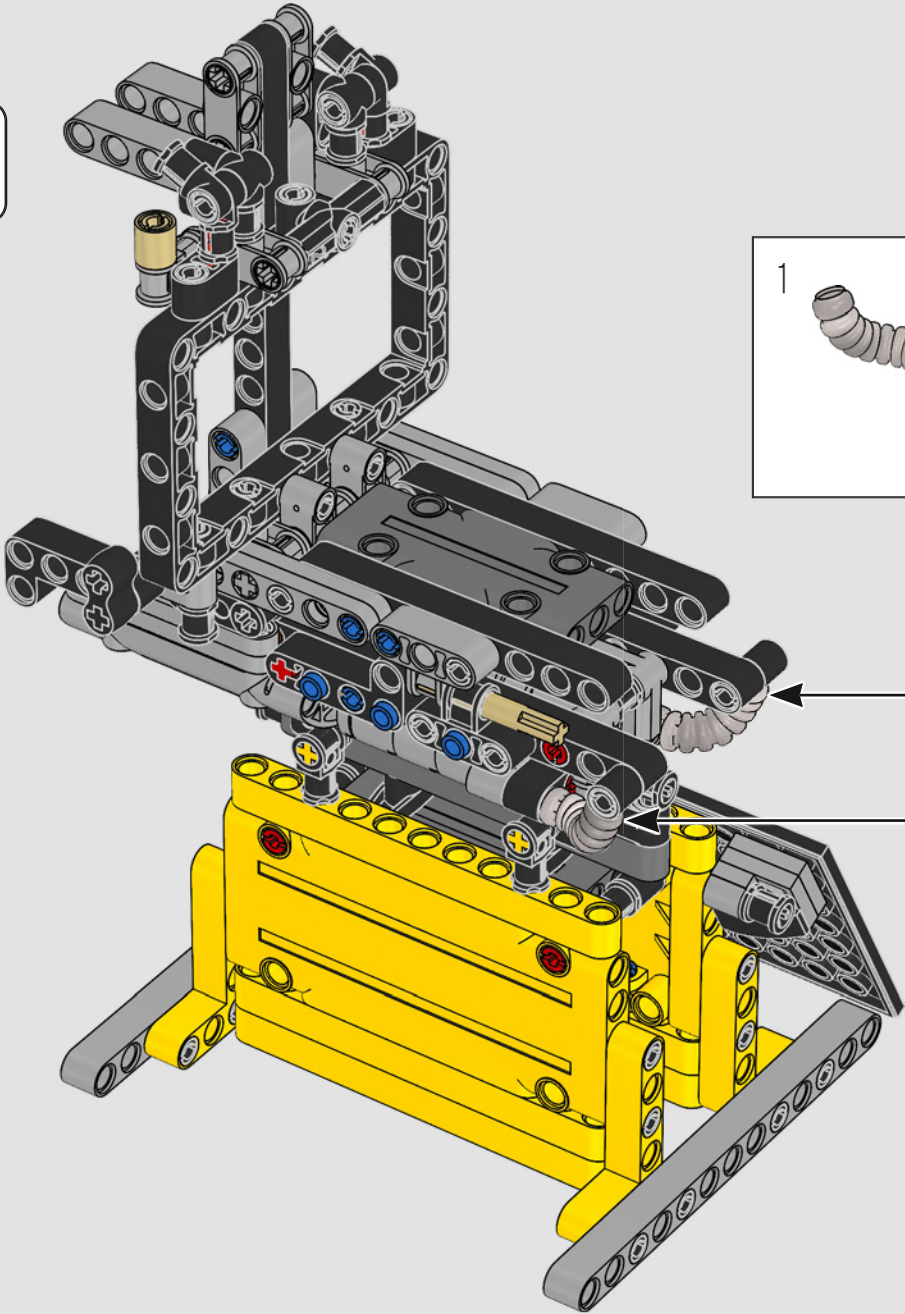

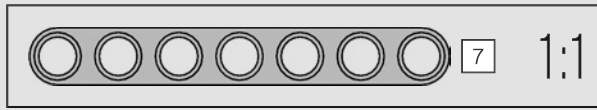
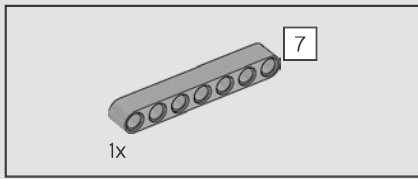

256

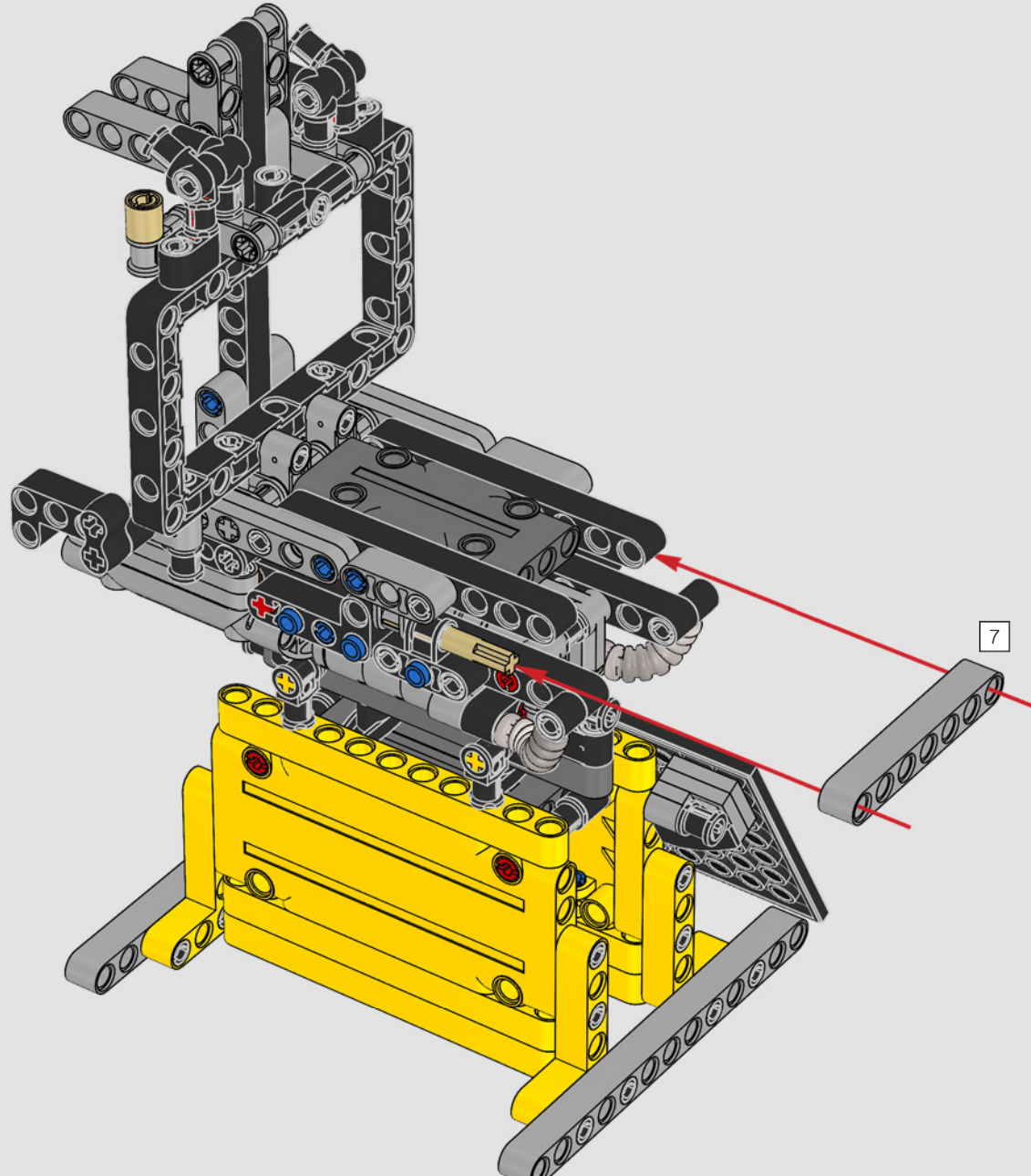

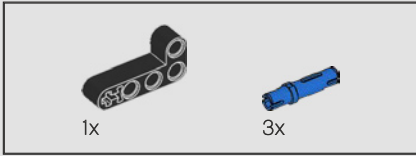
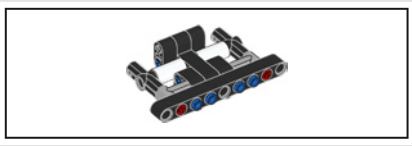

257

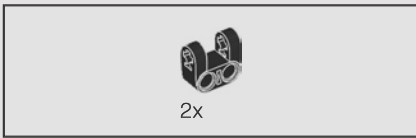
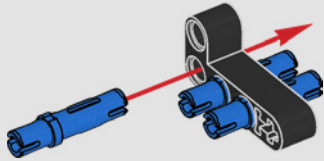

258

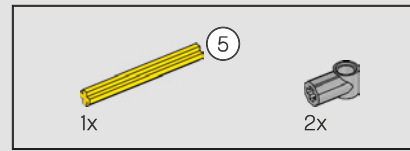
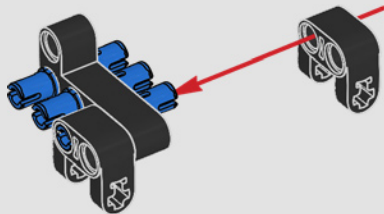

259

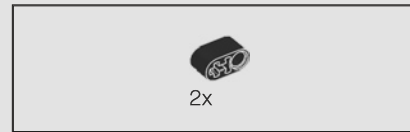
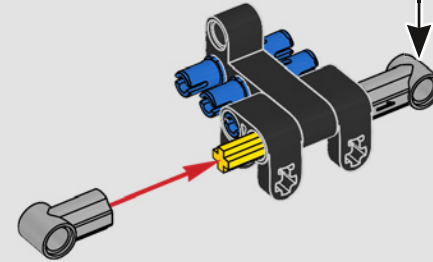
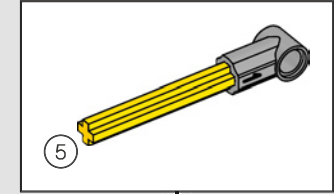

260

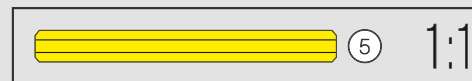
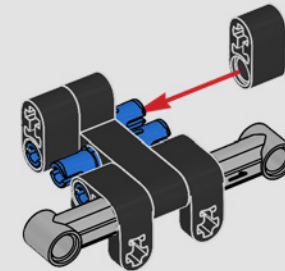



261

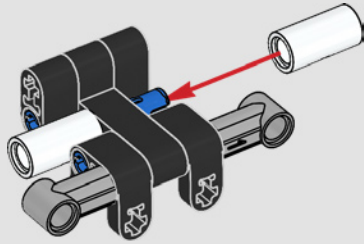

262

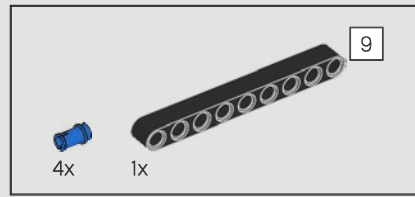
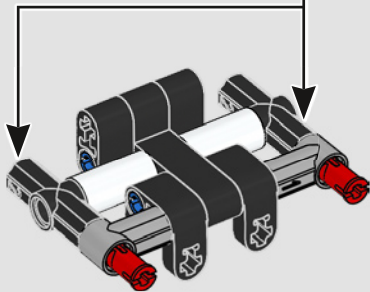
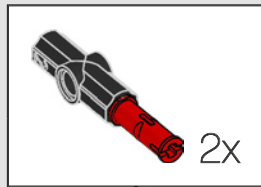

263

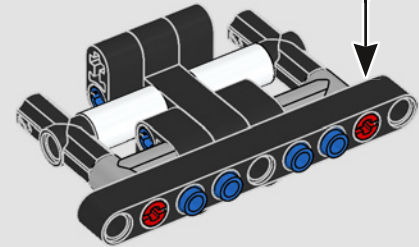
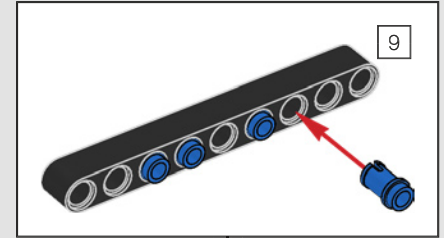

264

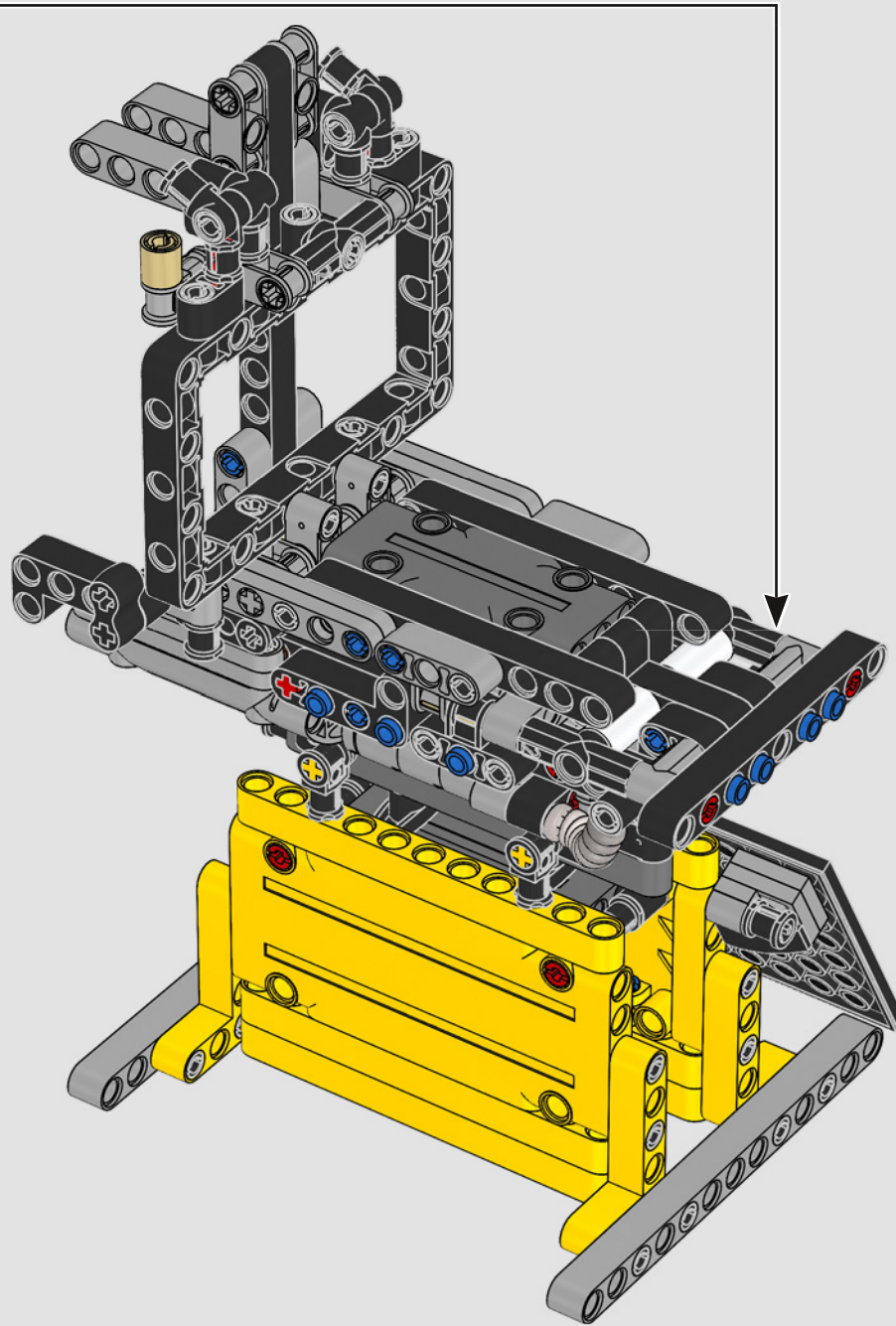

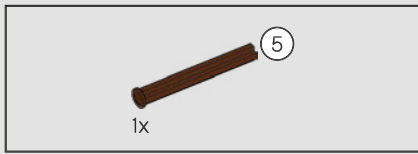

265

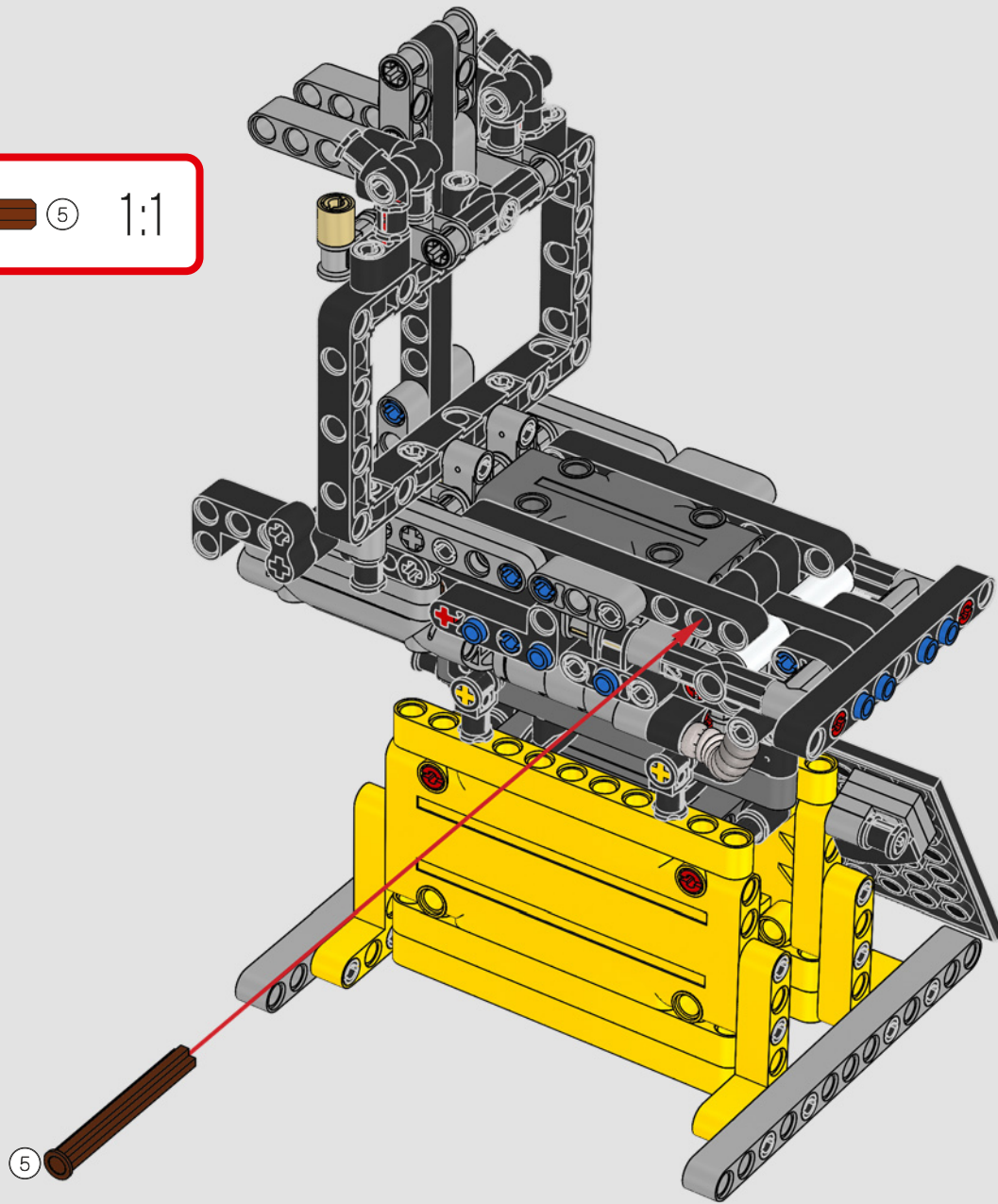

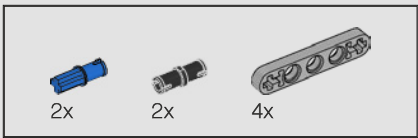

266

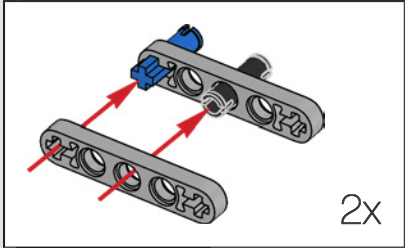
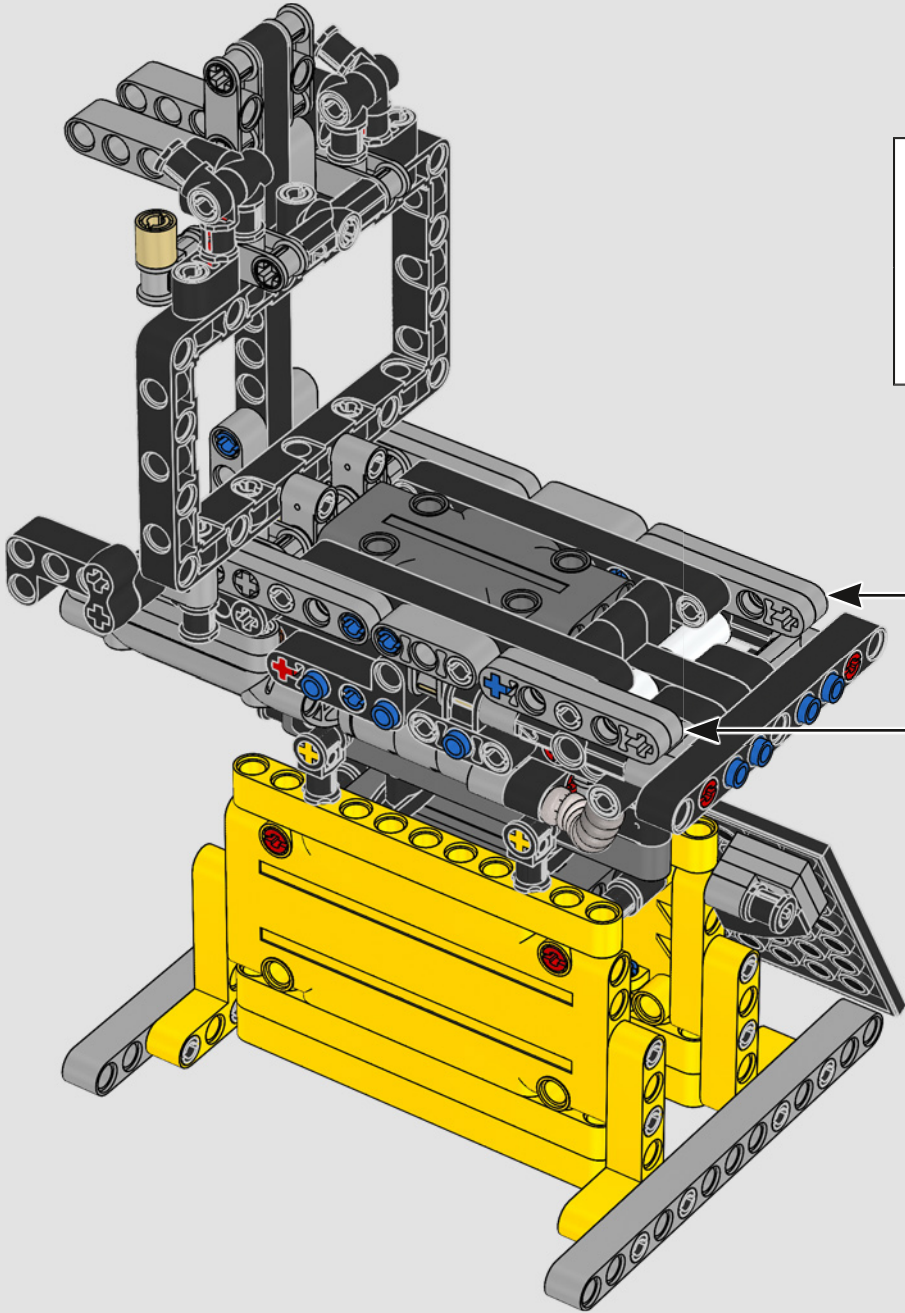

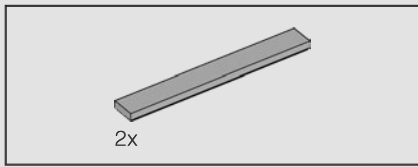

267

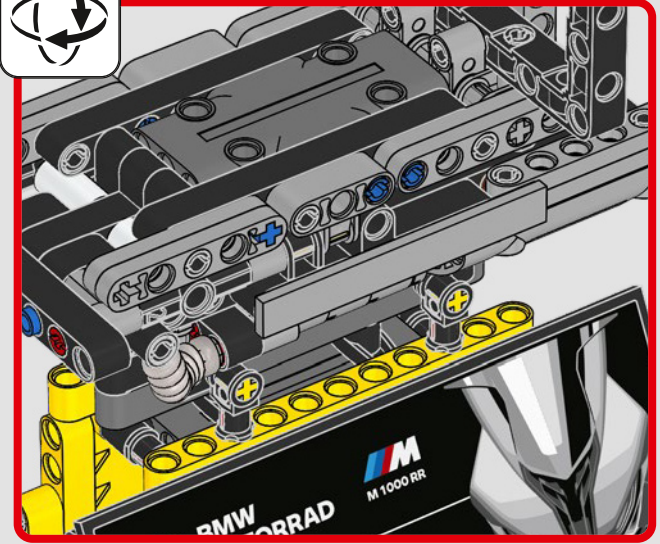
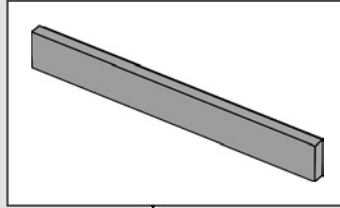
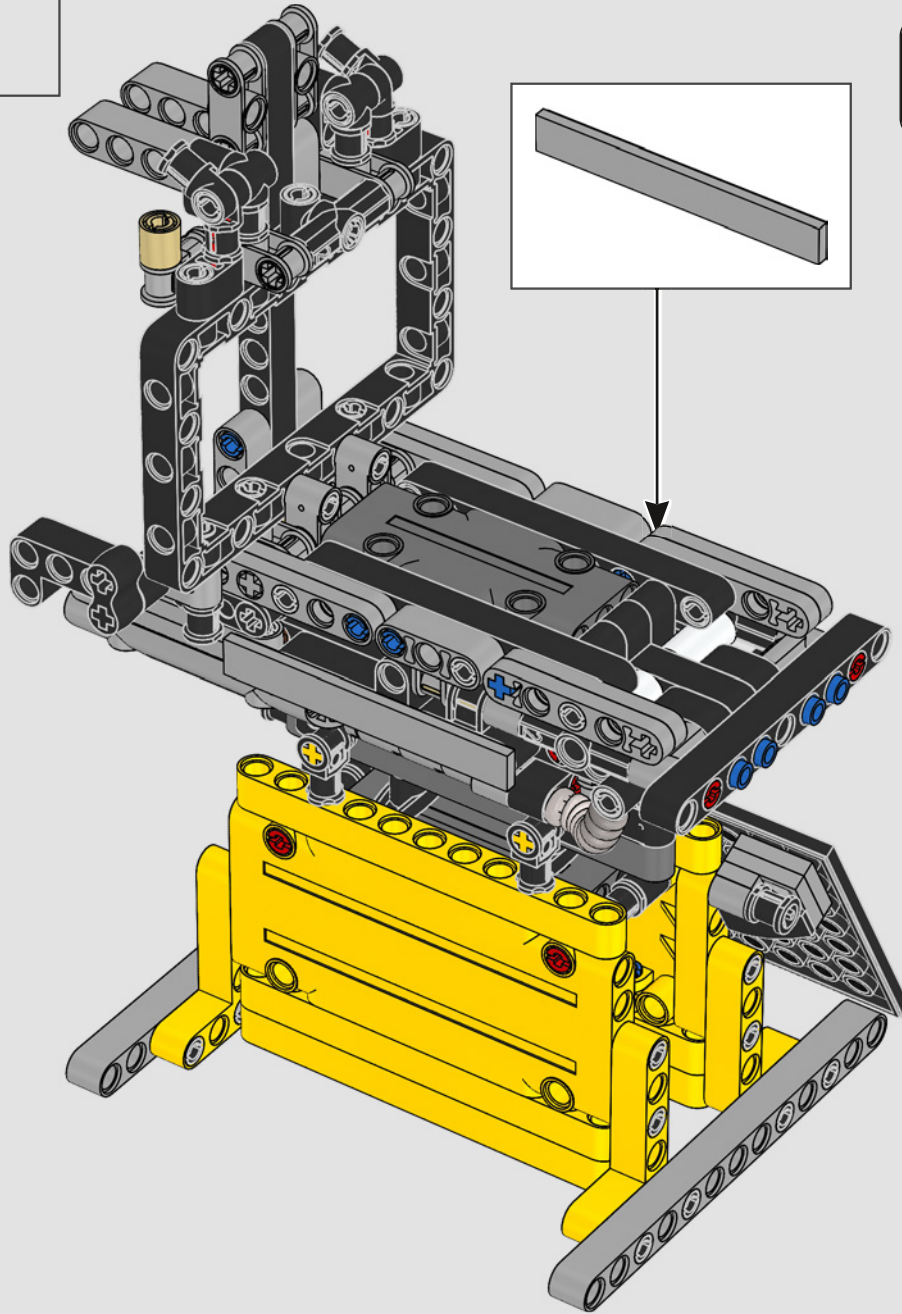

268

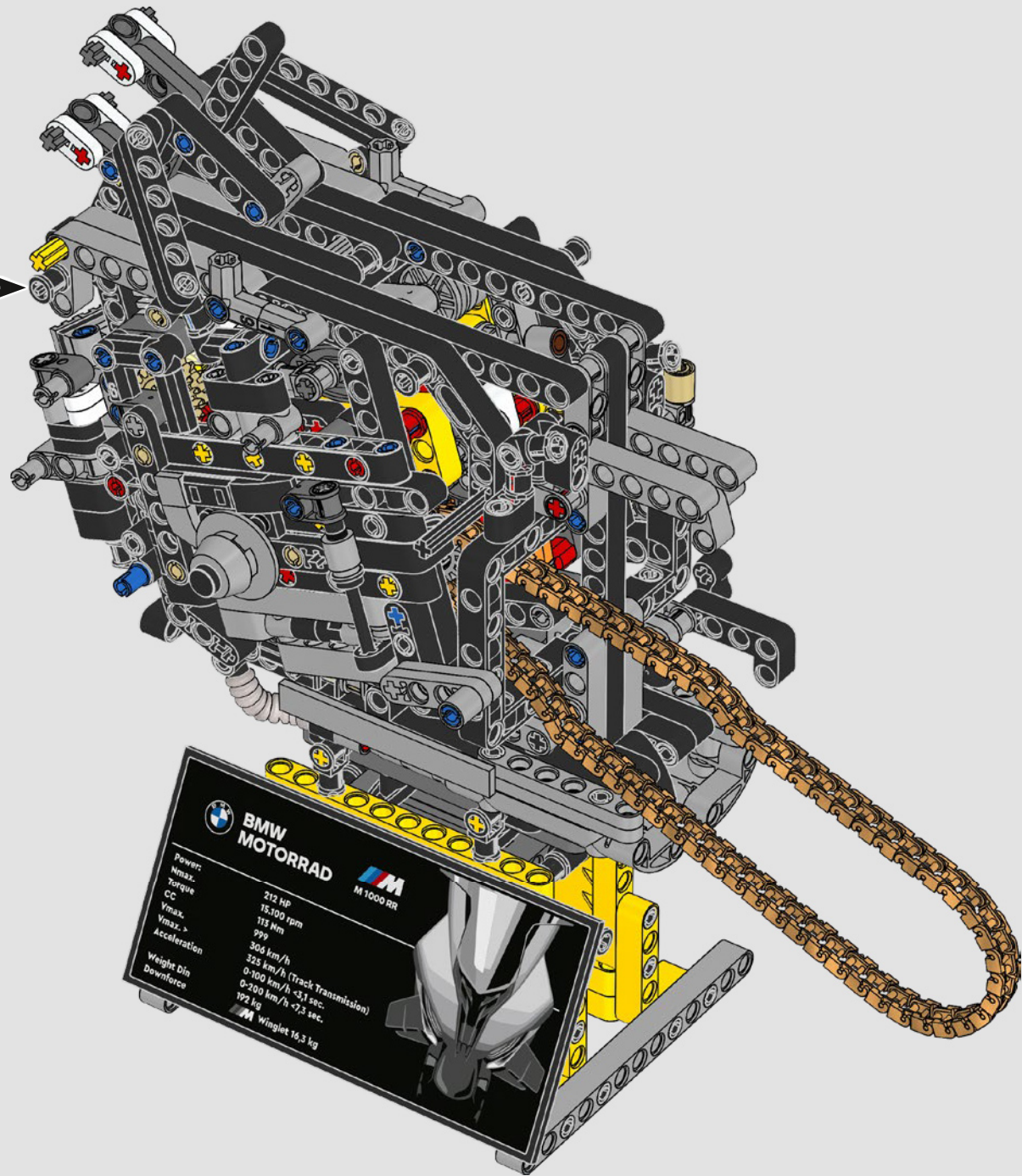

BMW
MOTORRAD

Power: 212 HP
Nmax. 15,100 rpm
Torque 113 Nm
CC 999
Vmax. 306 km/h
Vmax. > 325 km/h (Track Transmission)
Acceleration 0-100 km/h < 3.1 sec.
0-200 km/h < 7.3 sec.

Weight Din 192 kg
Downforce

M M1000 RR
Winglet 16.3 kg

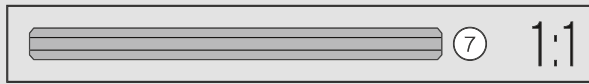
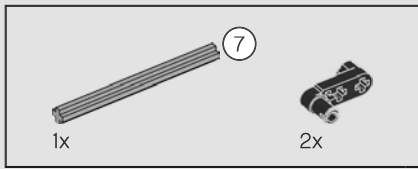

269

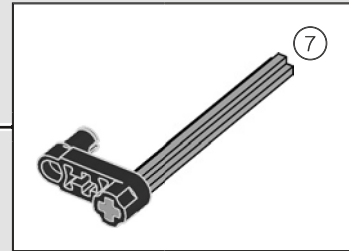
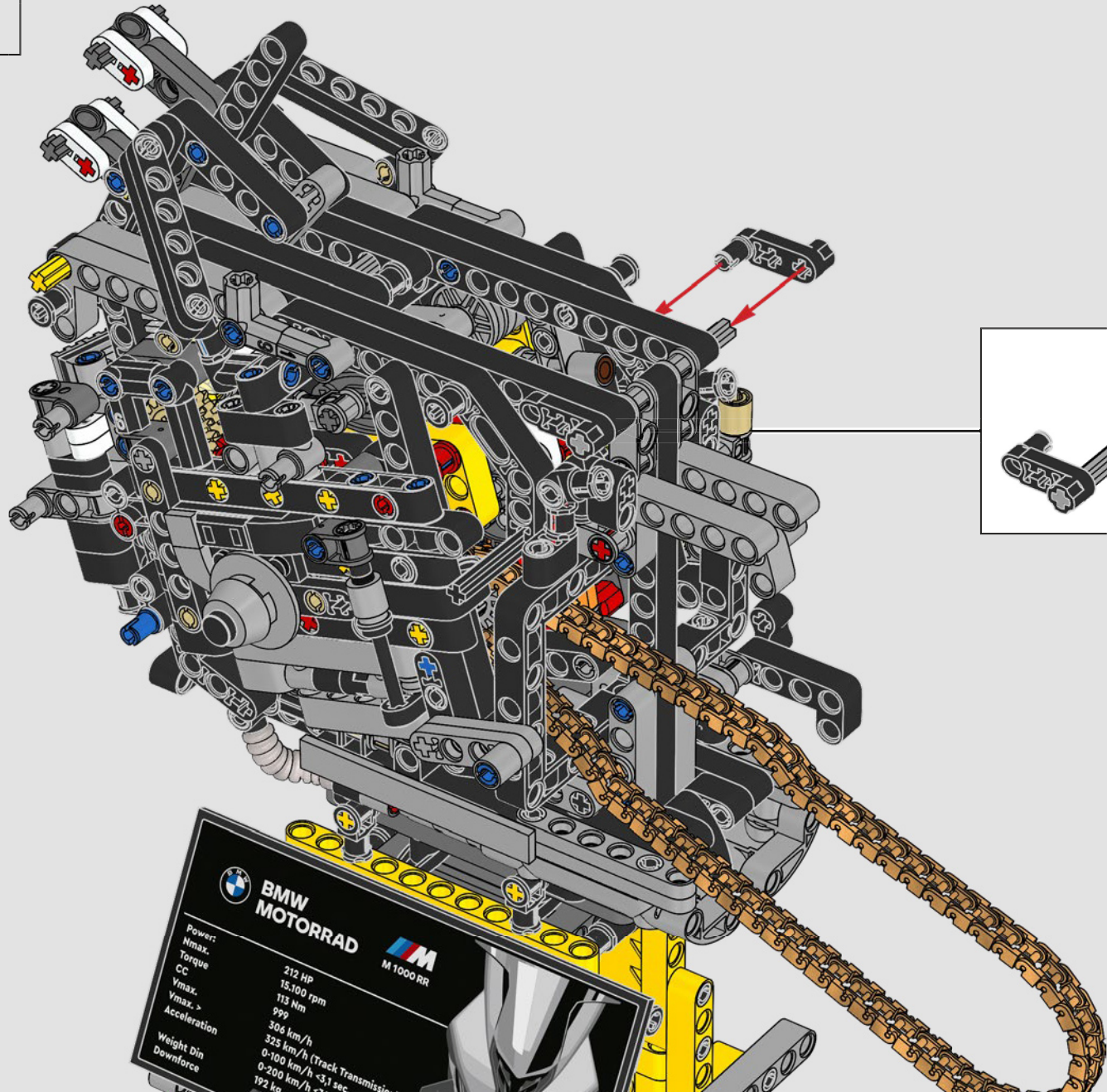

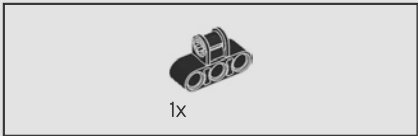

BMW MOTORRAD		M 1000 RR
Power:	212 HP	
Nmax:	15.100 rpm	
Torque	113 Nm	
CC	999	
Vmax:	326 km/h	
Vmax. >	325 km/h (Track Transmission)	
Acceleration	0-100 km/h < 3.1 sec	
Weight Din	192 kg	
Downforce		

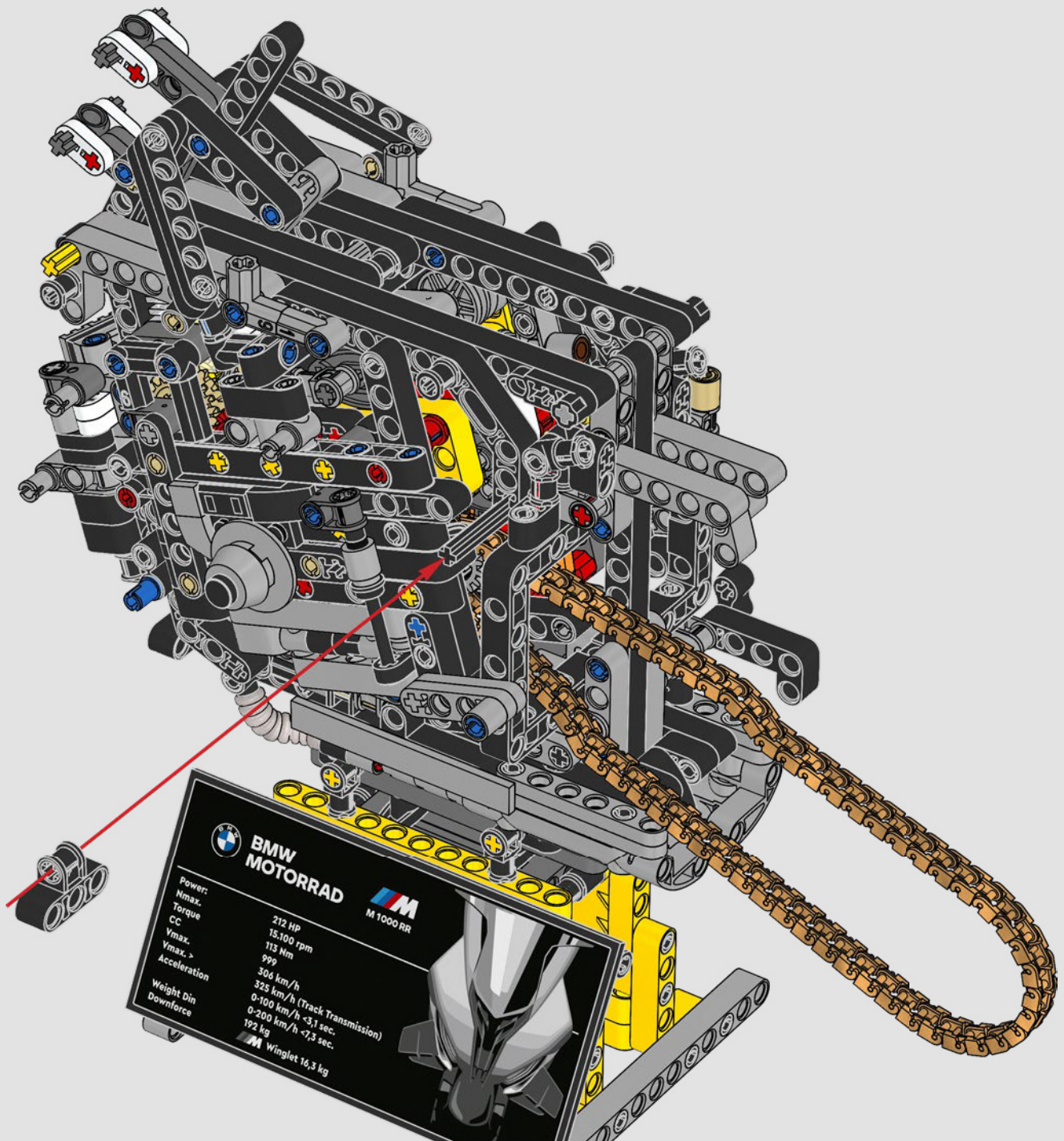

270



BMW MOTORRAD  **M 1000 RR**

Power:	212 HP
Hmax:	15-100 rpm
Torque	113 Nm
CC	999
Vmax:	306 km/h
Vmax. >	326 km/h (Track Transmission)
Acceleration	0-100 km/h <3,1 sec.
Weight Din	0-200 km/h ~7,3 sec.
Downforce	192 kg
	 Winglet 16,3 kg



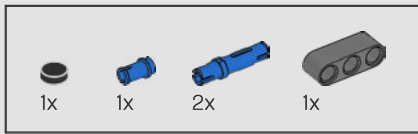

271

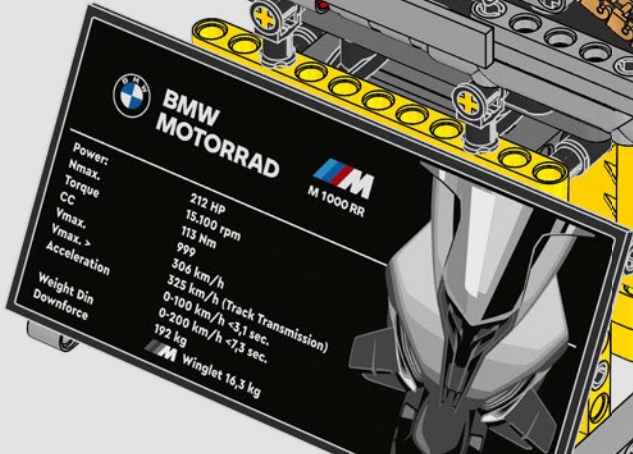
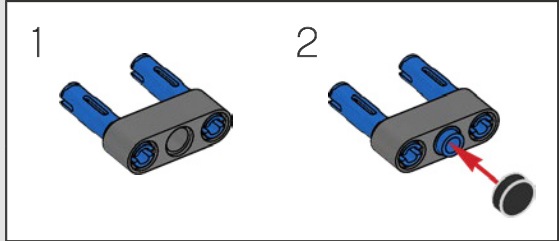
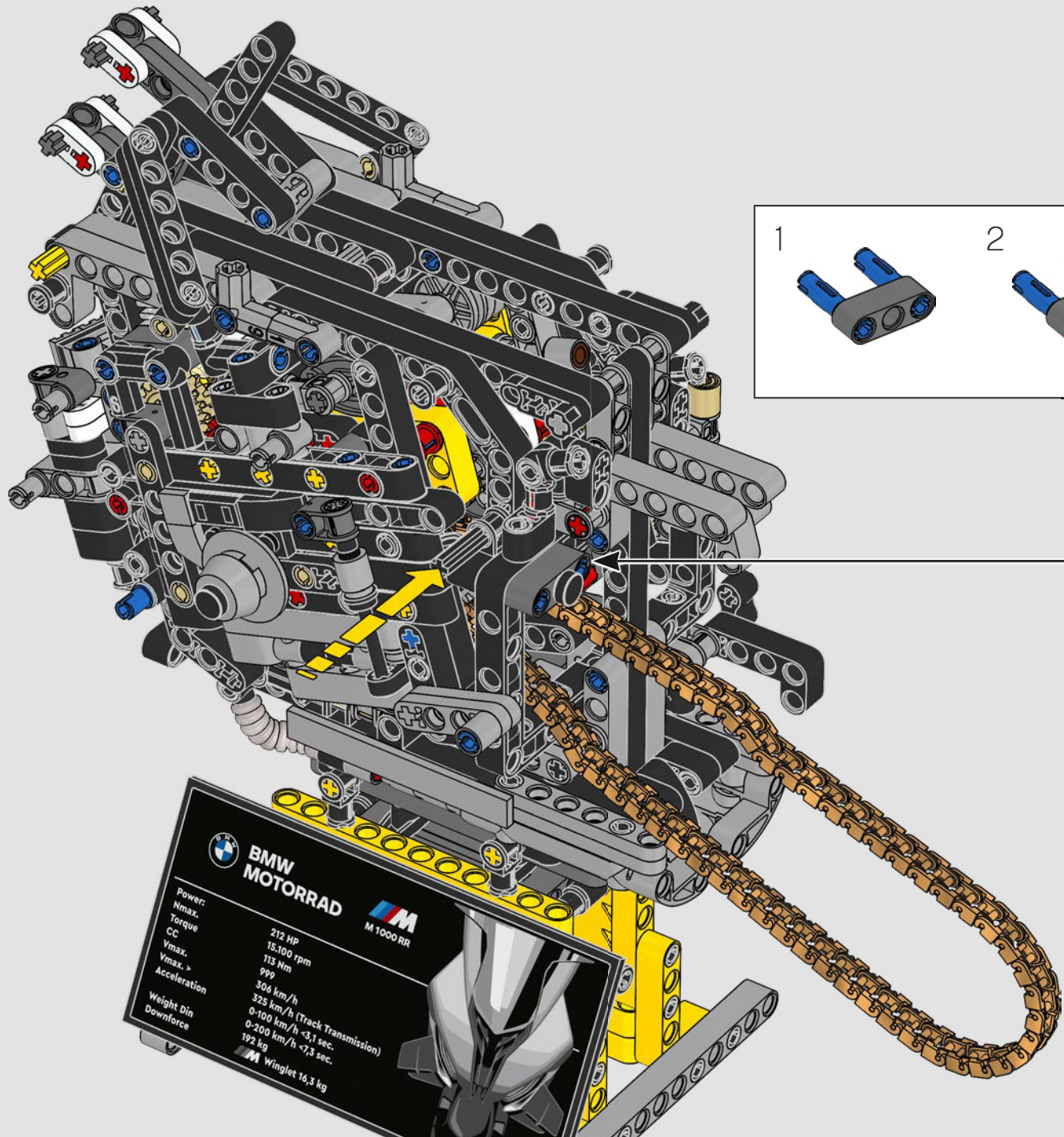



272

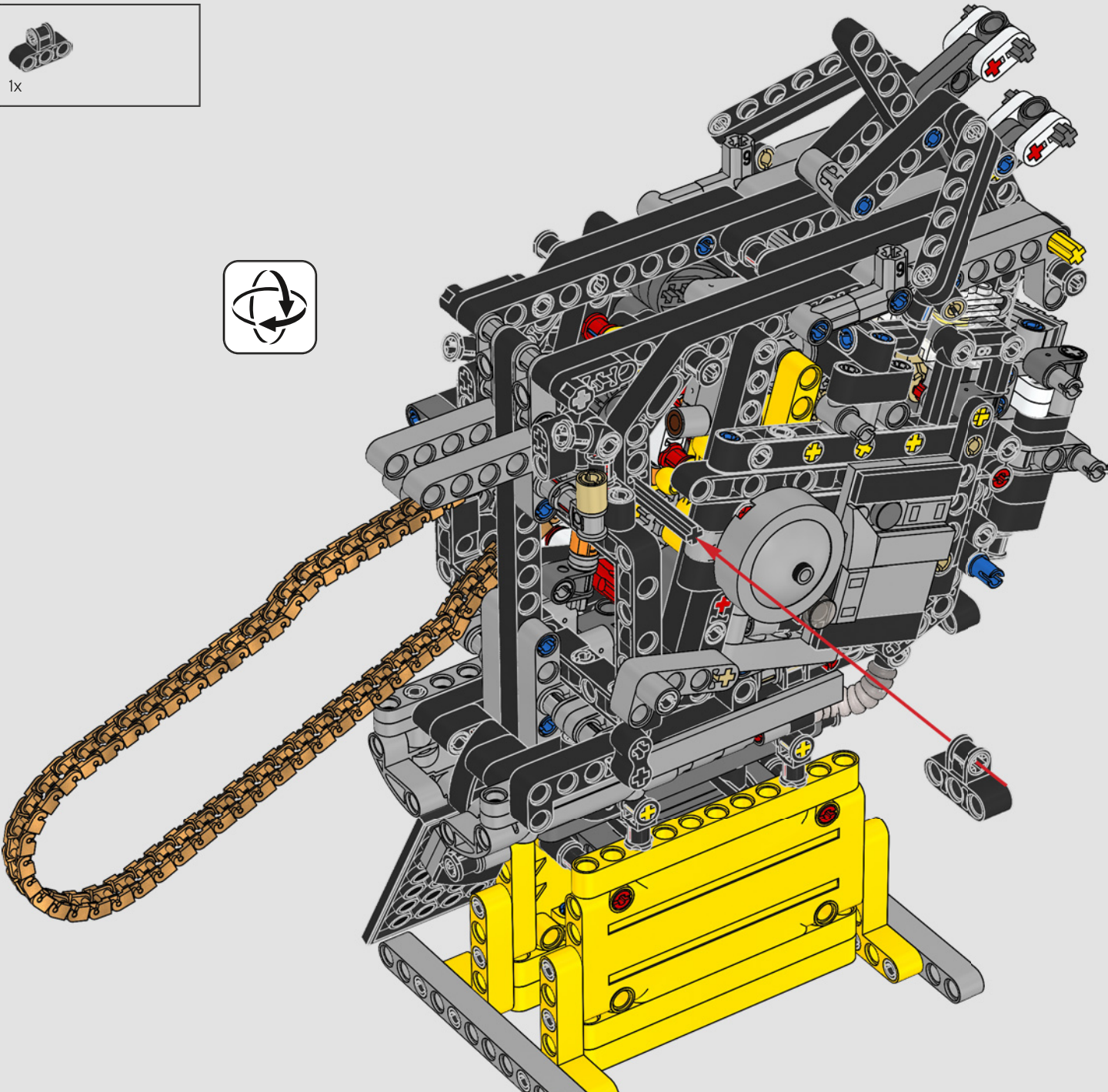

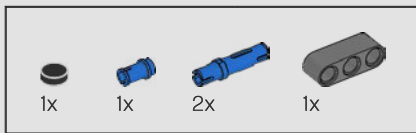

273

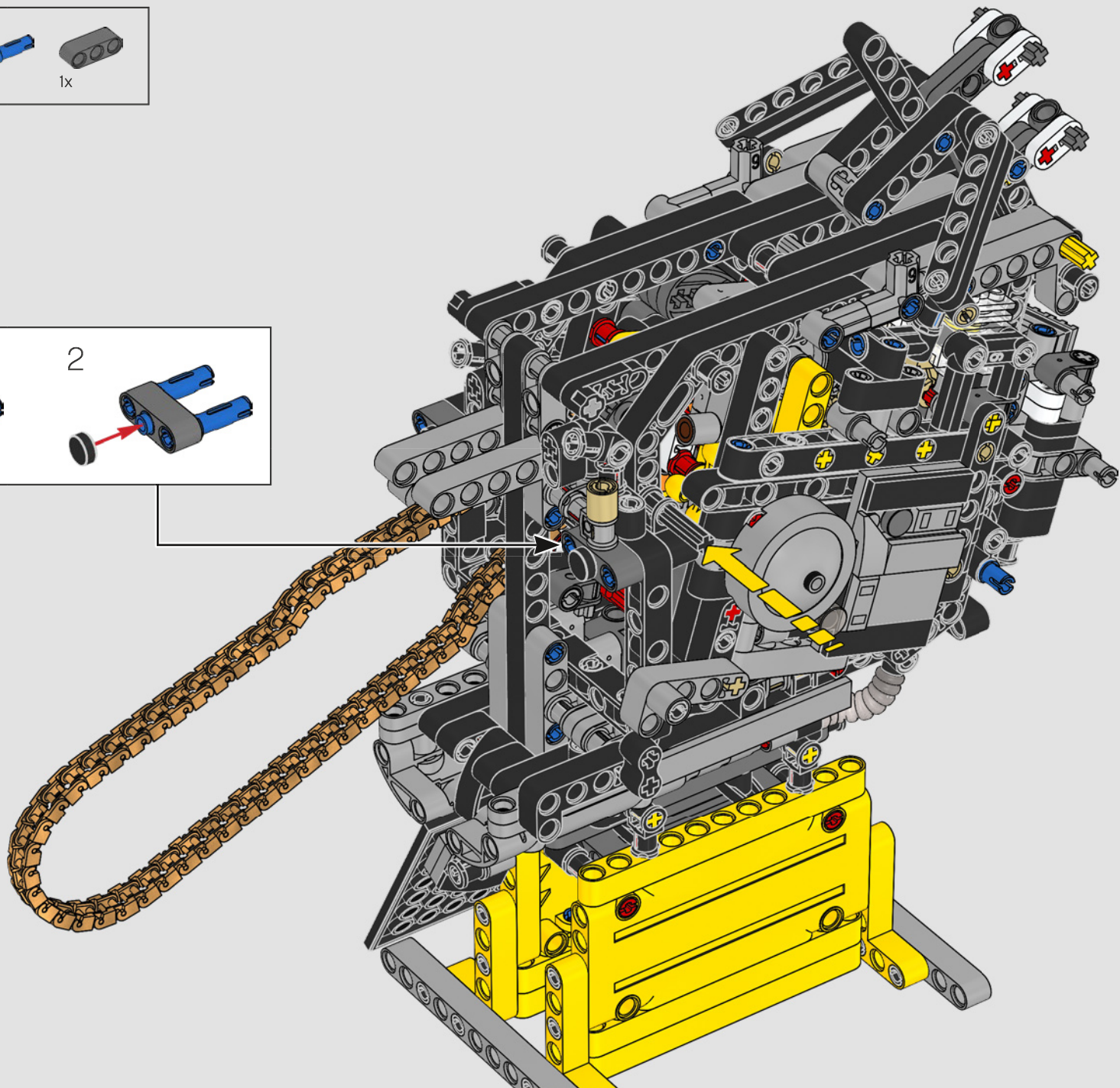
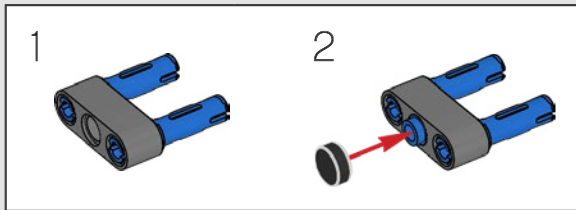

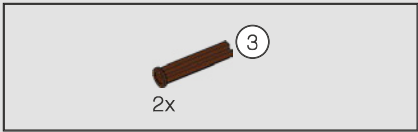

274

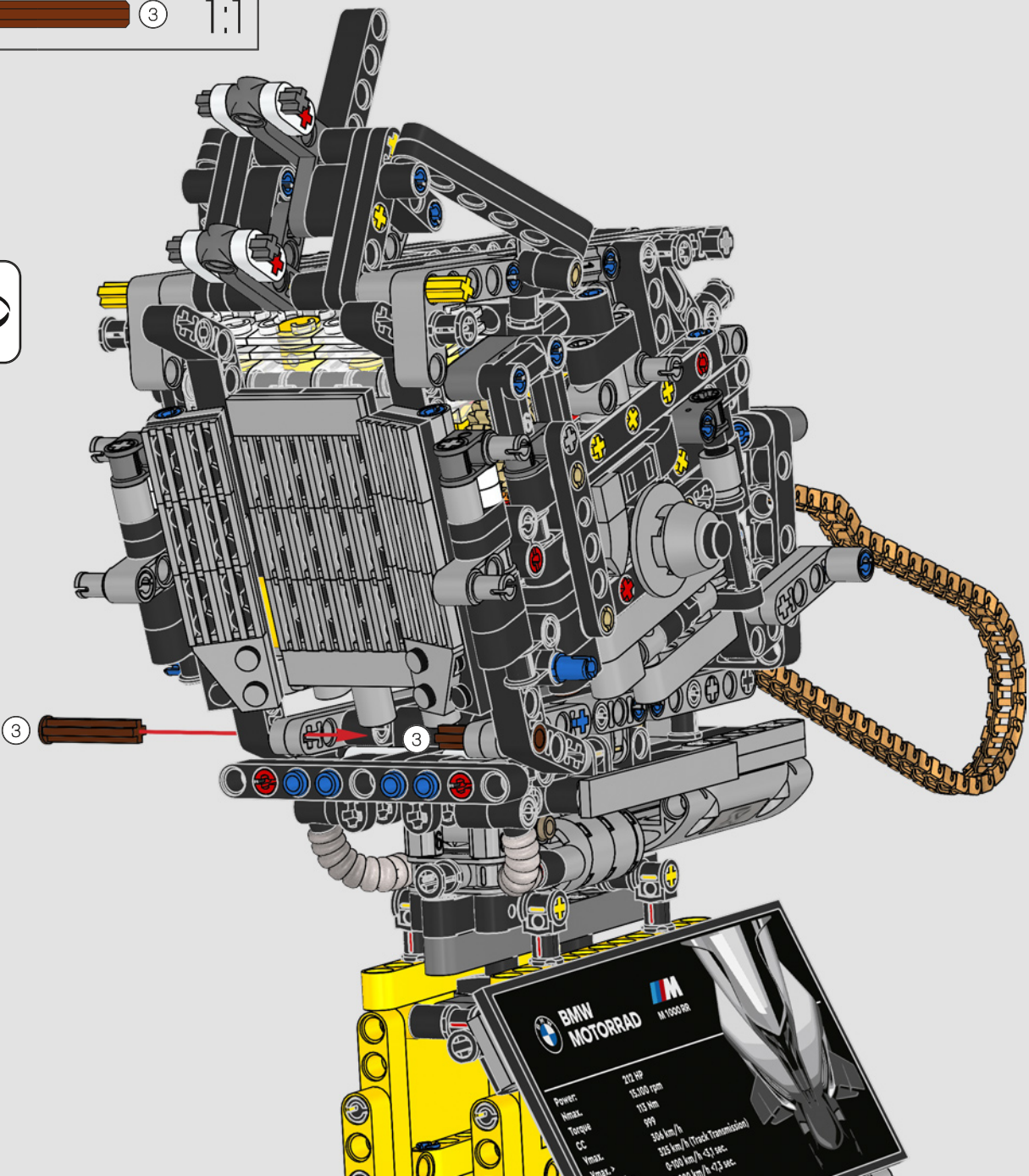



2x



3x



2x

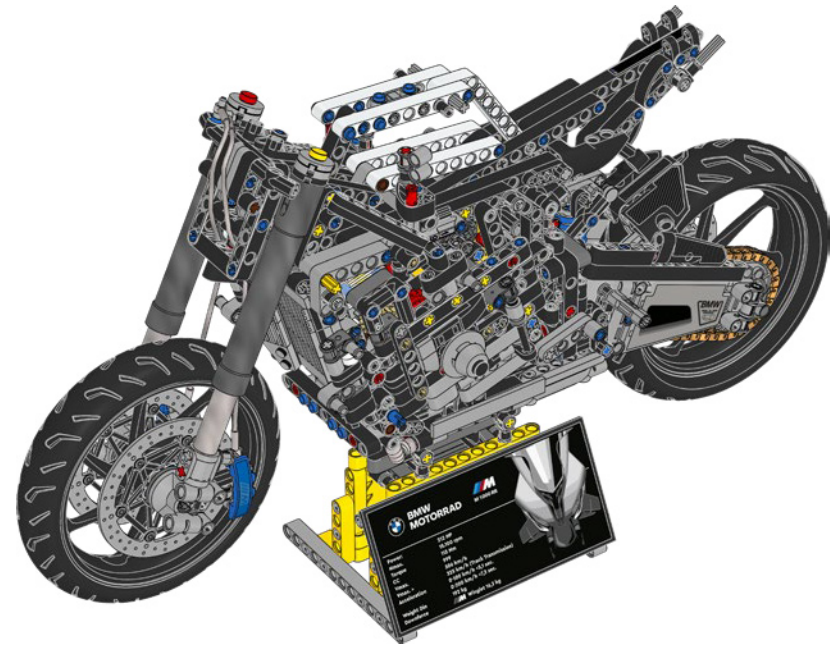
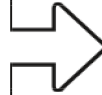



2x

275



2x

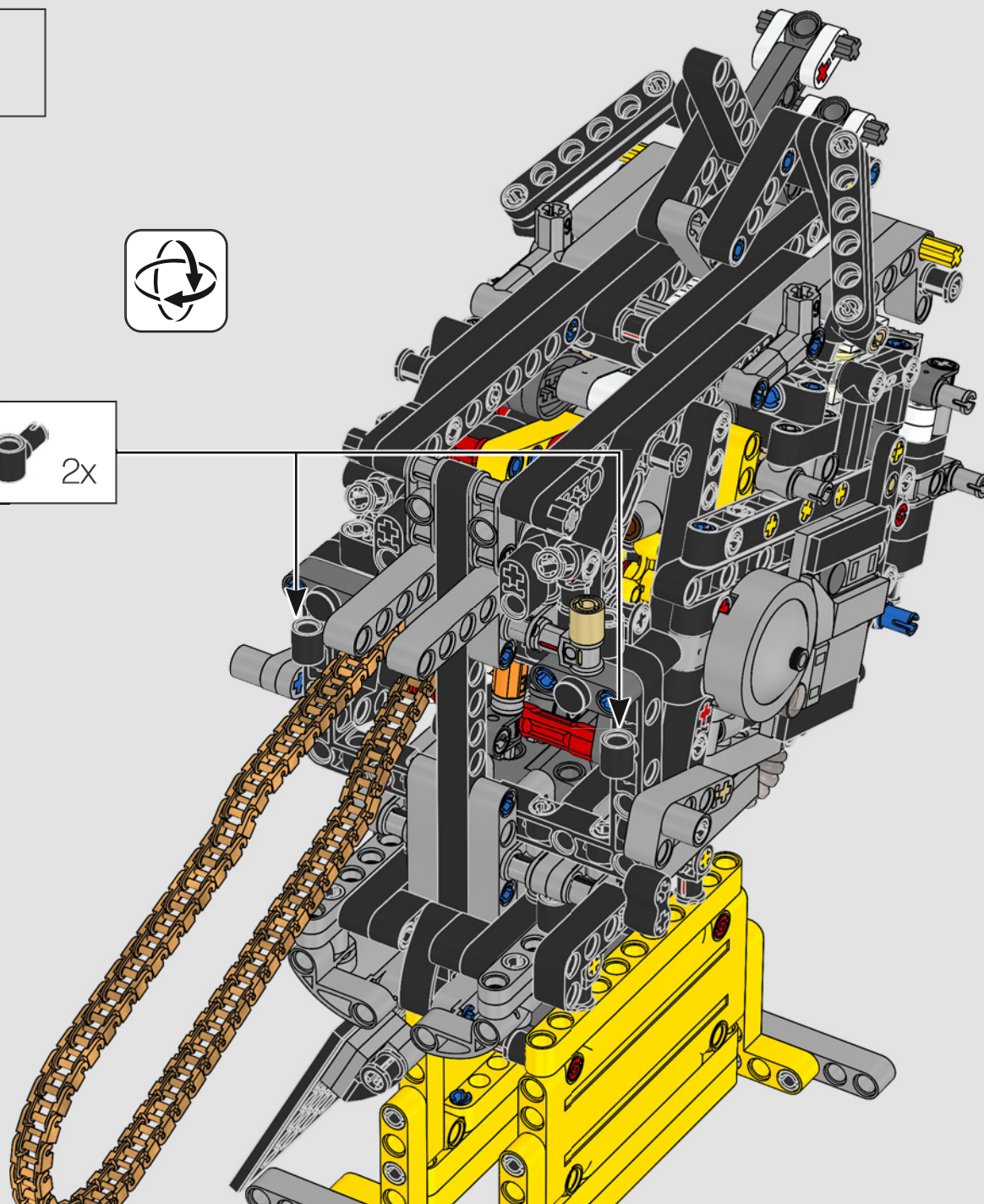

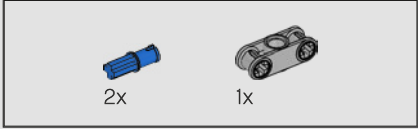
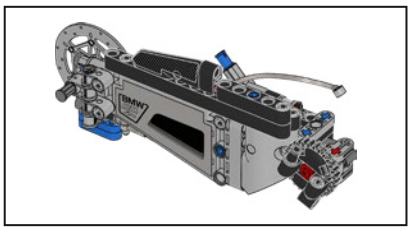

276

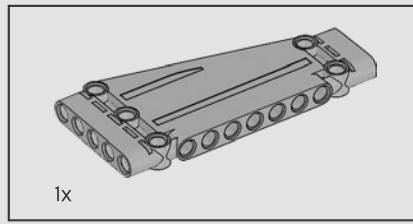
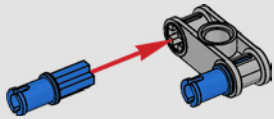

277

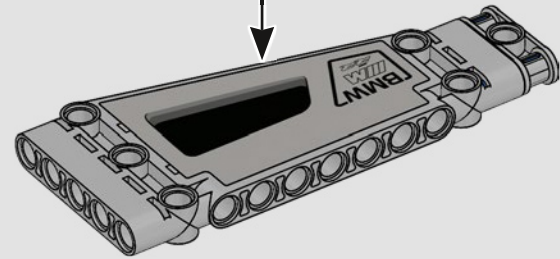
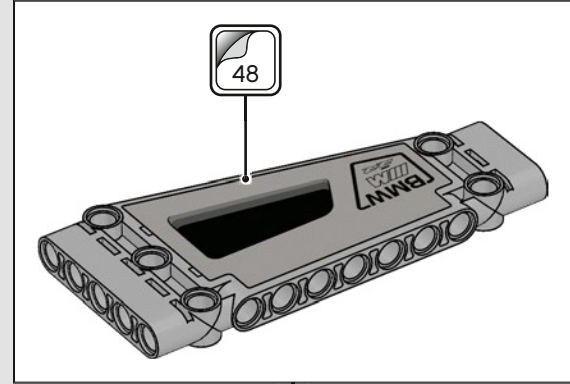

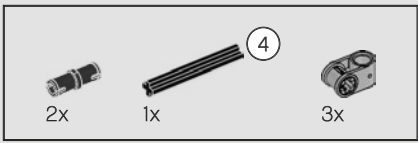

278

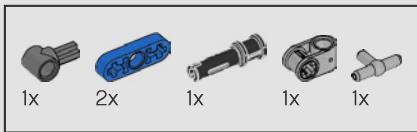
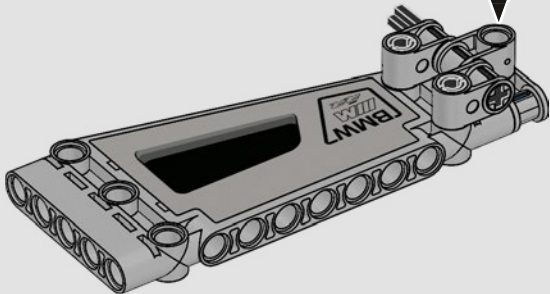
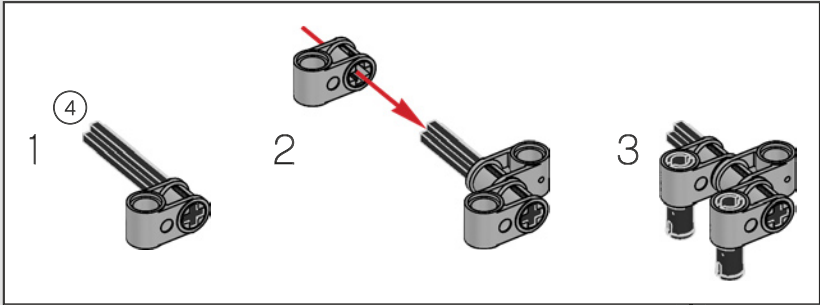

279

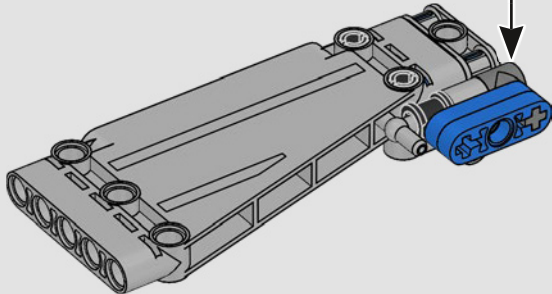
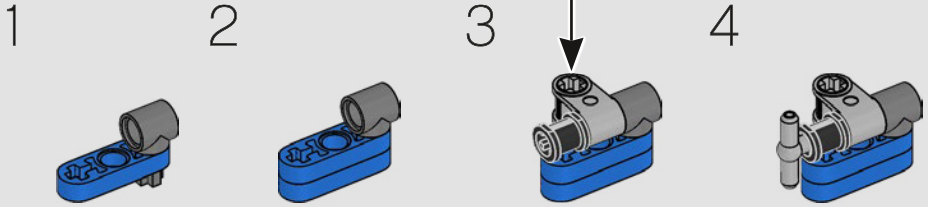
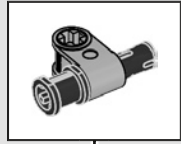

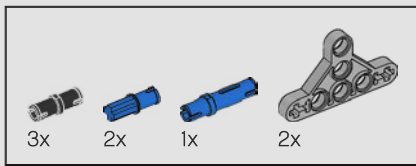

280

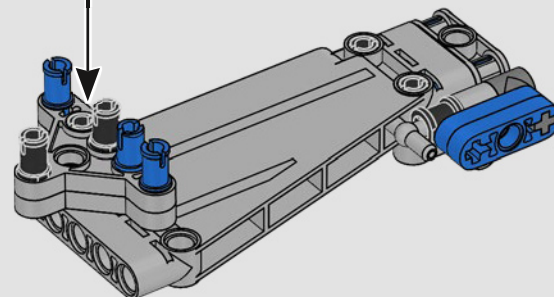
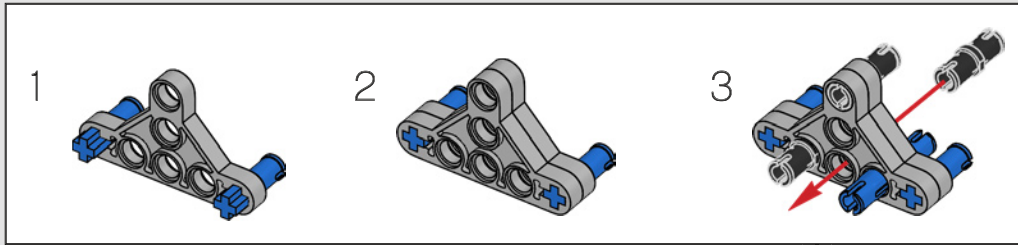

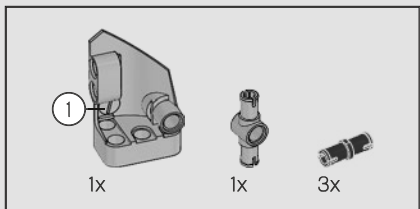

281

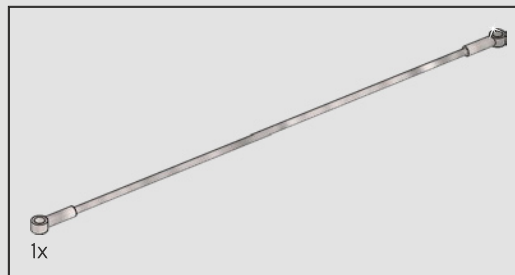
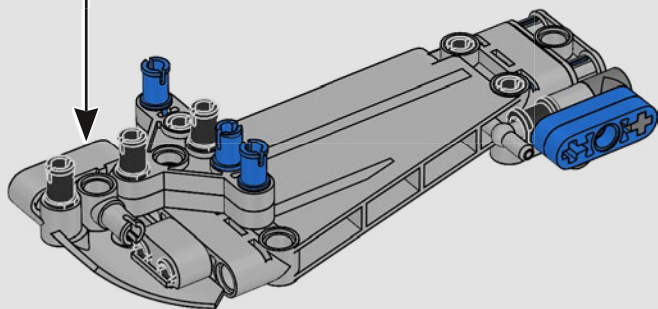
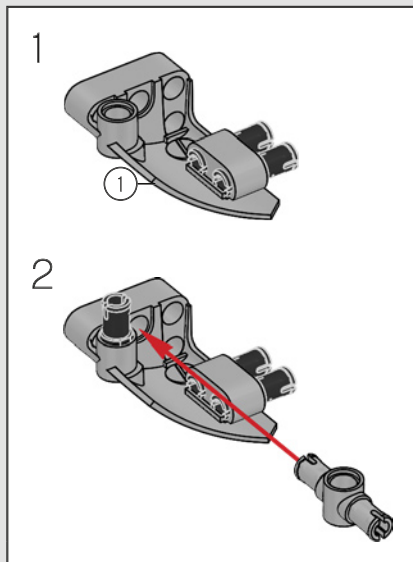

282

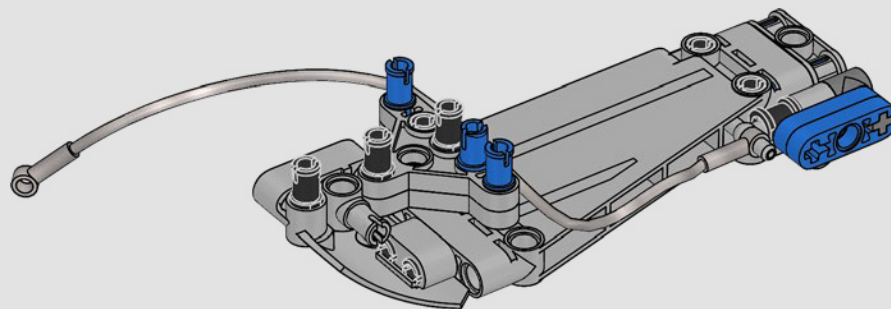

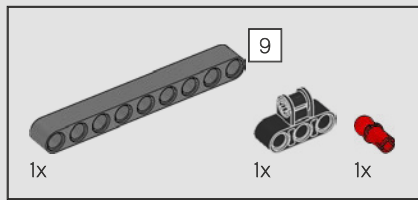

283

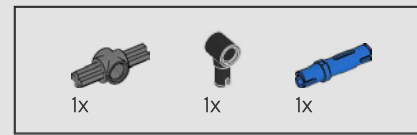
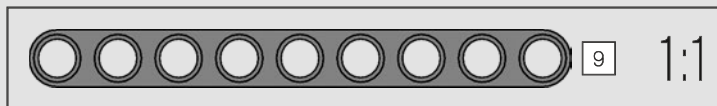
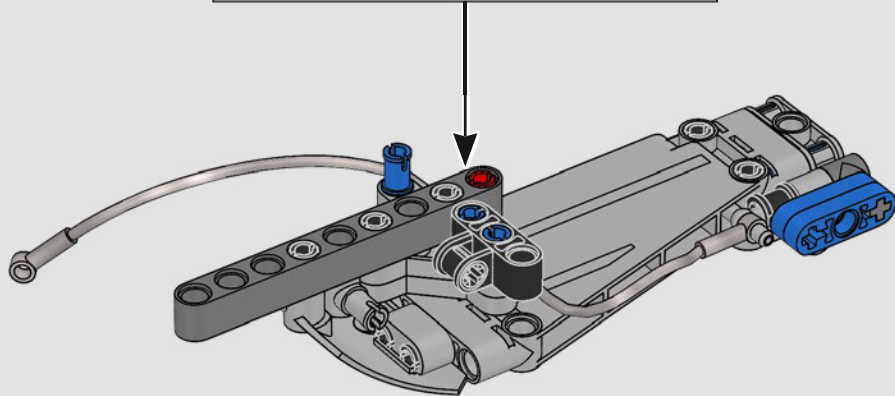
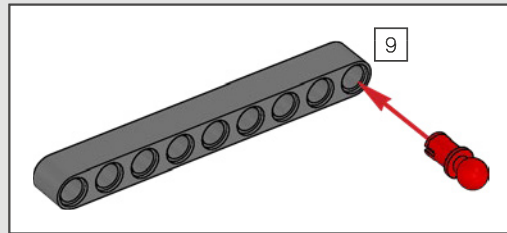
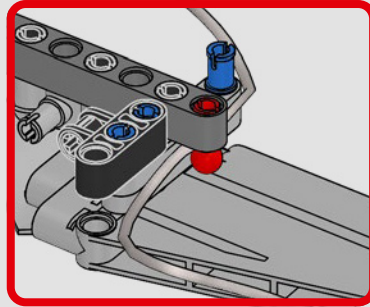

284

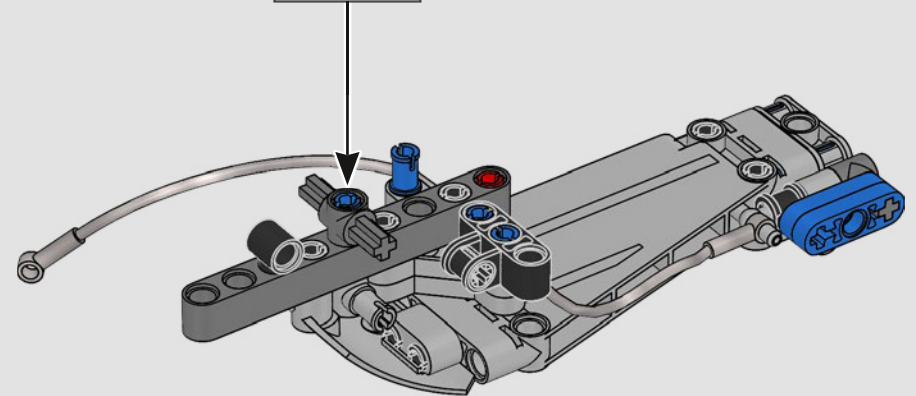
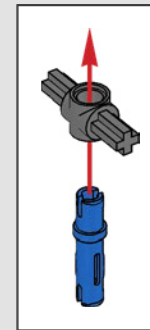

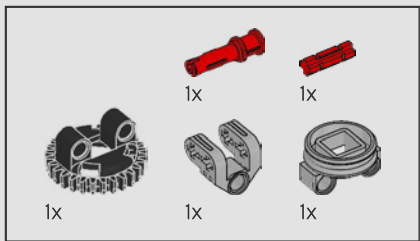

285

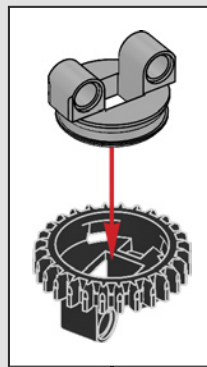

1

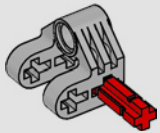

2

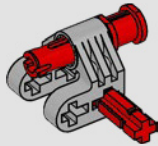

3

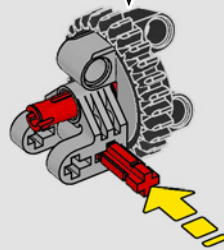

4

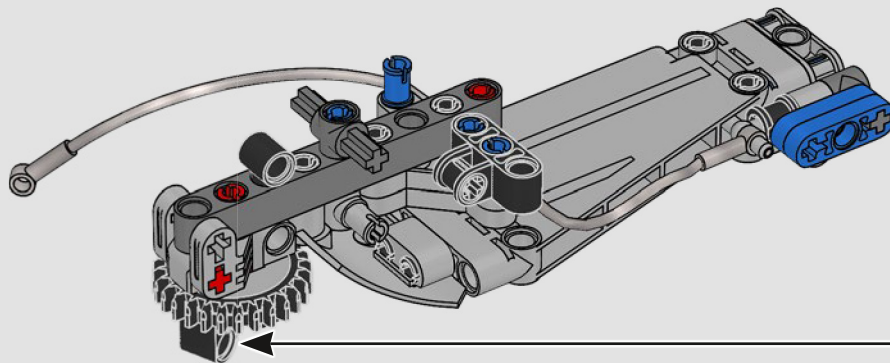

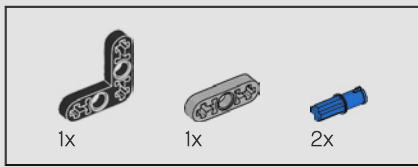

286

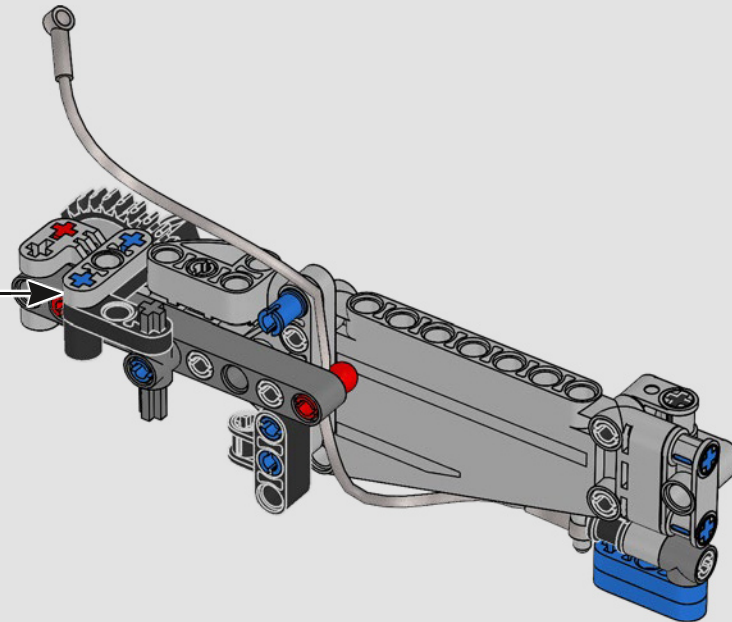
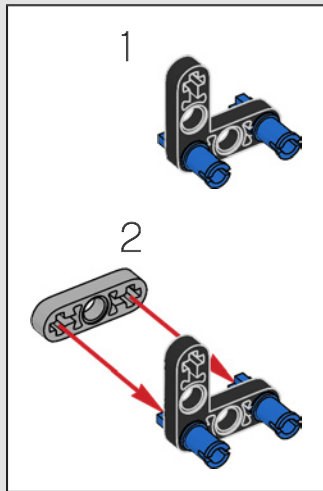

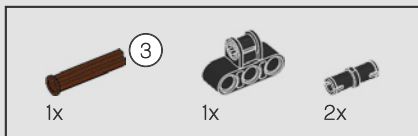

287

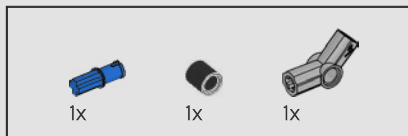
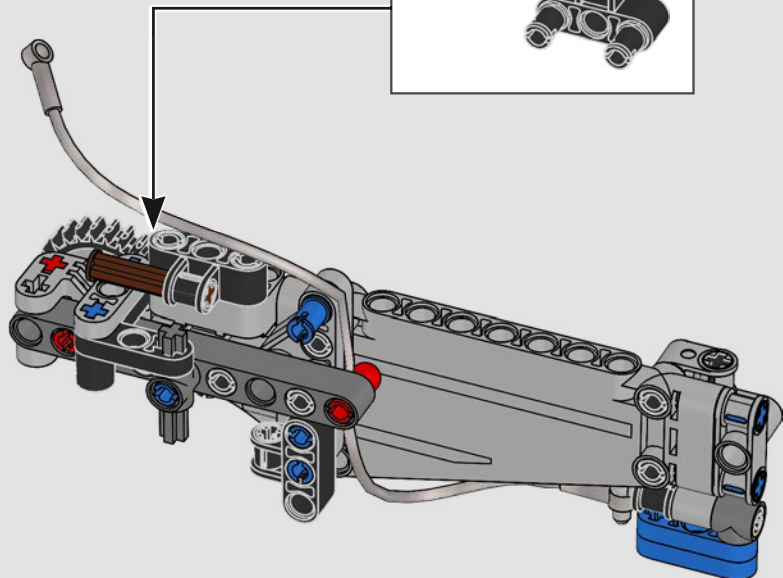
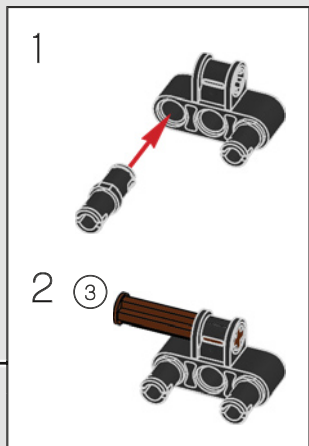

288

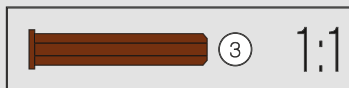
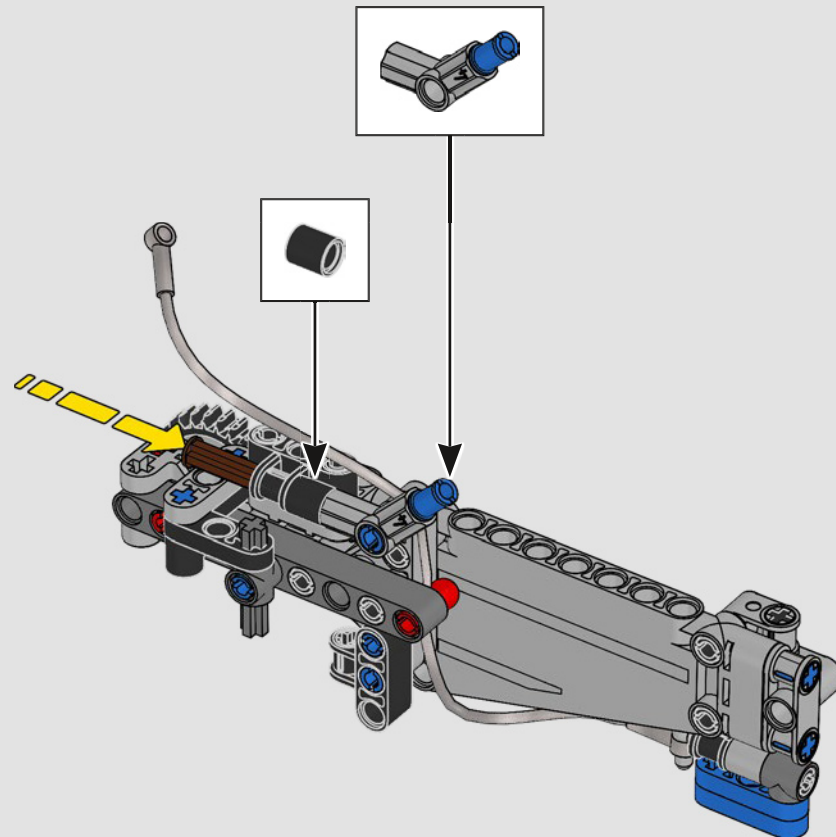

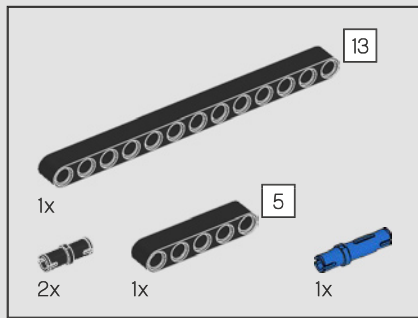

289

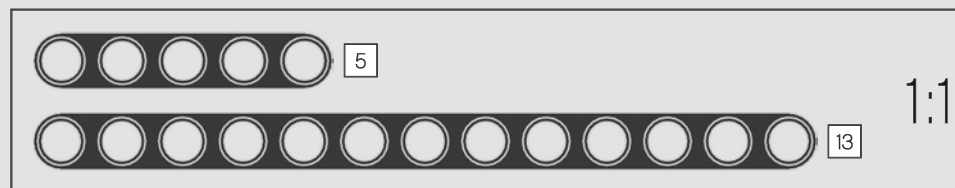
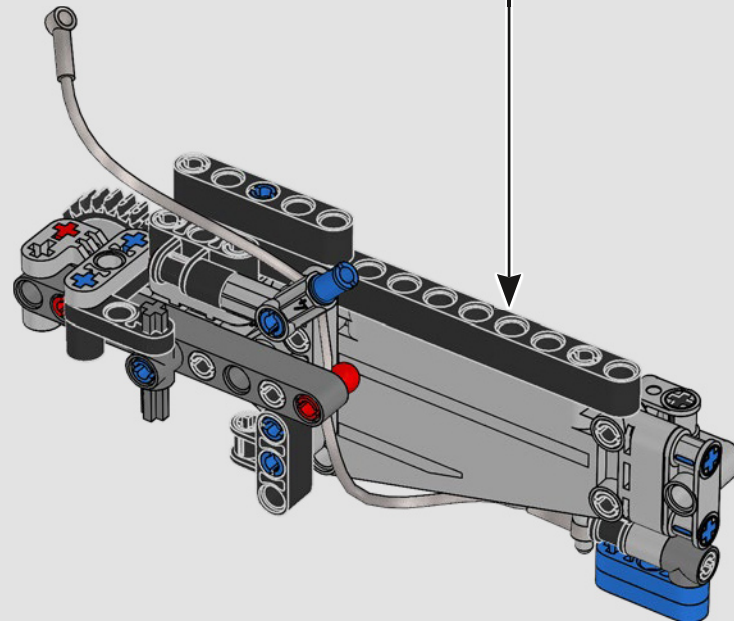
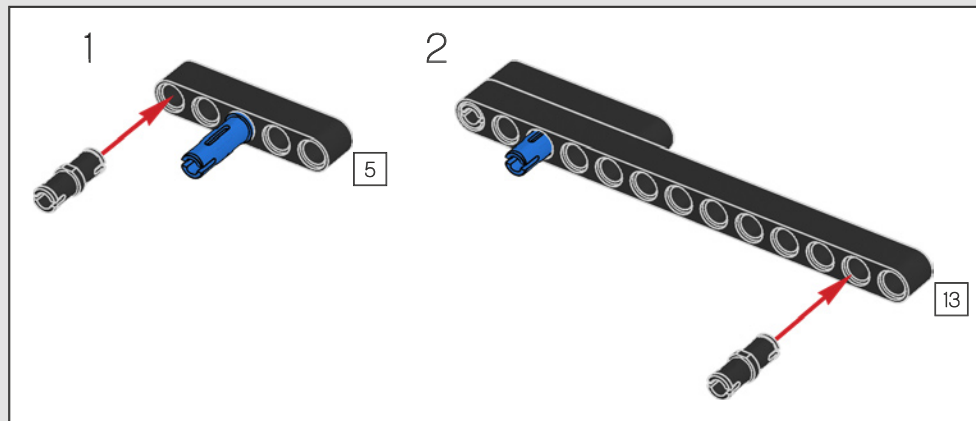

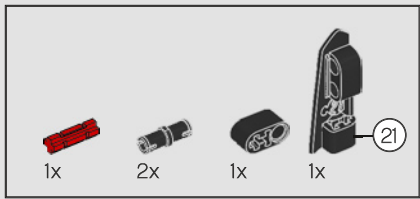

290

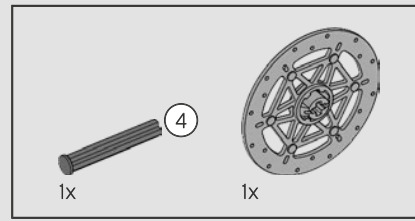
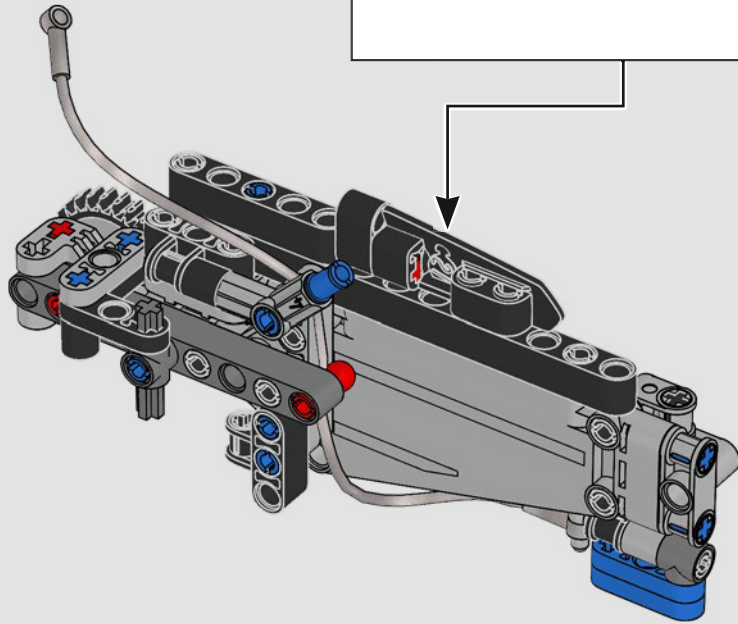
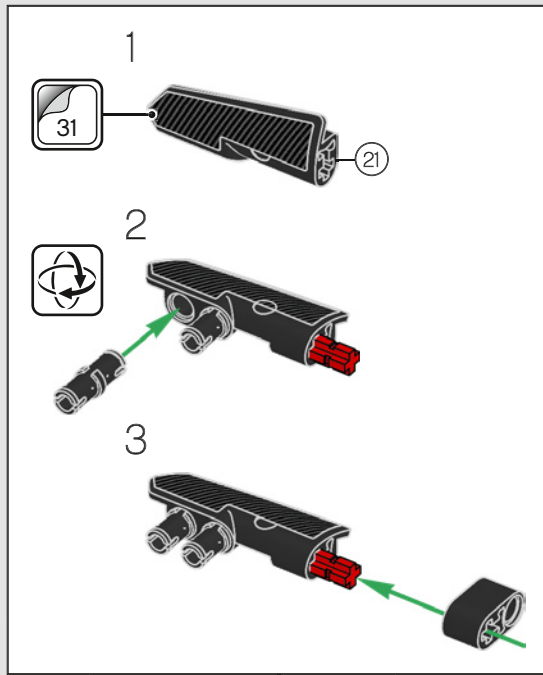

291

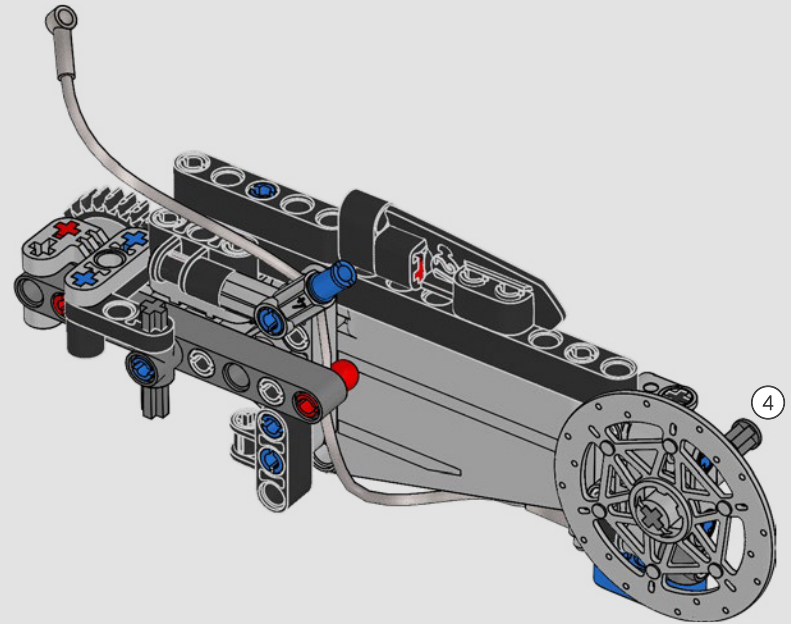
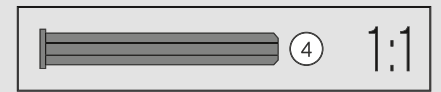

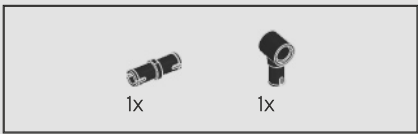

292

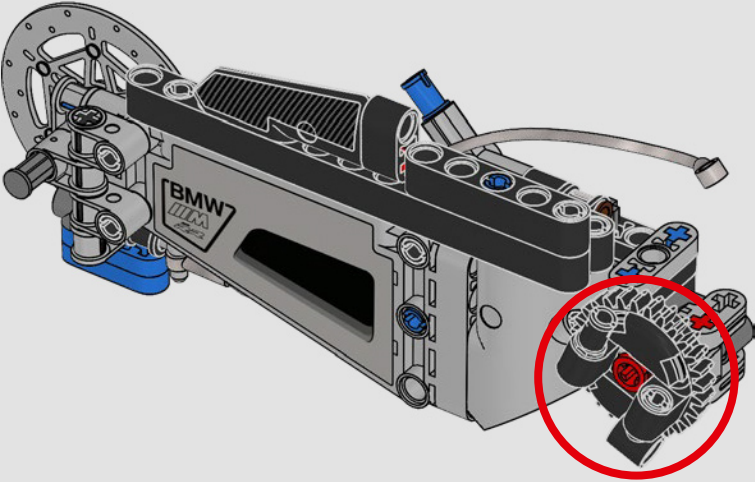

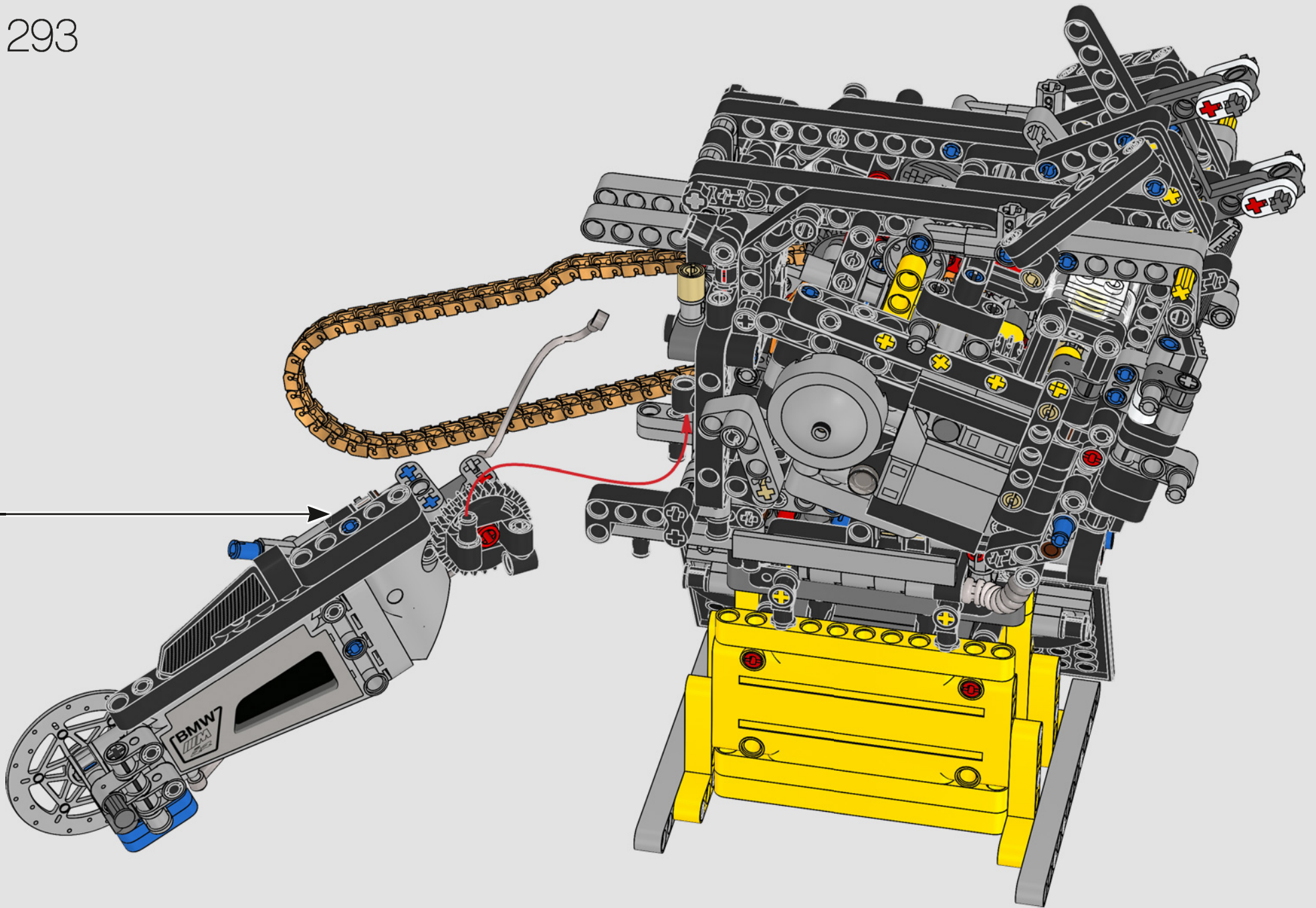

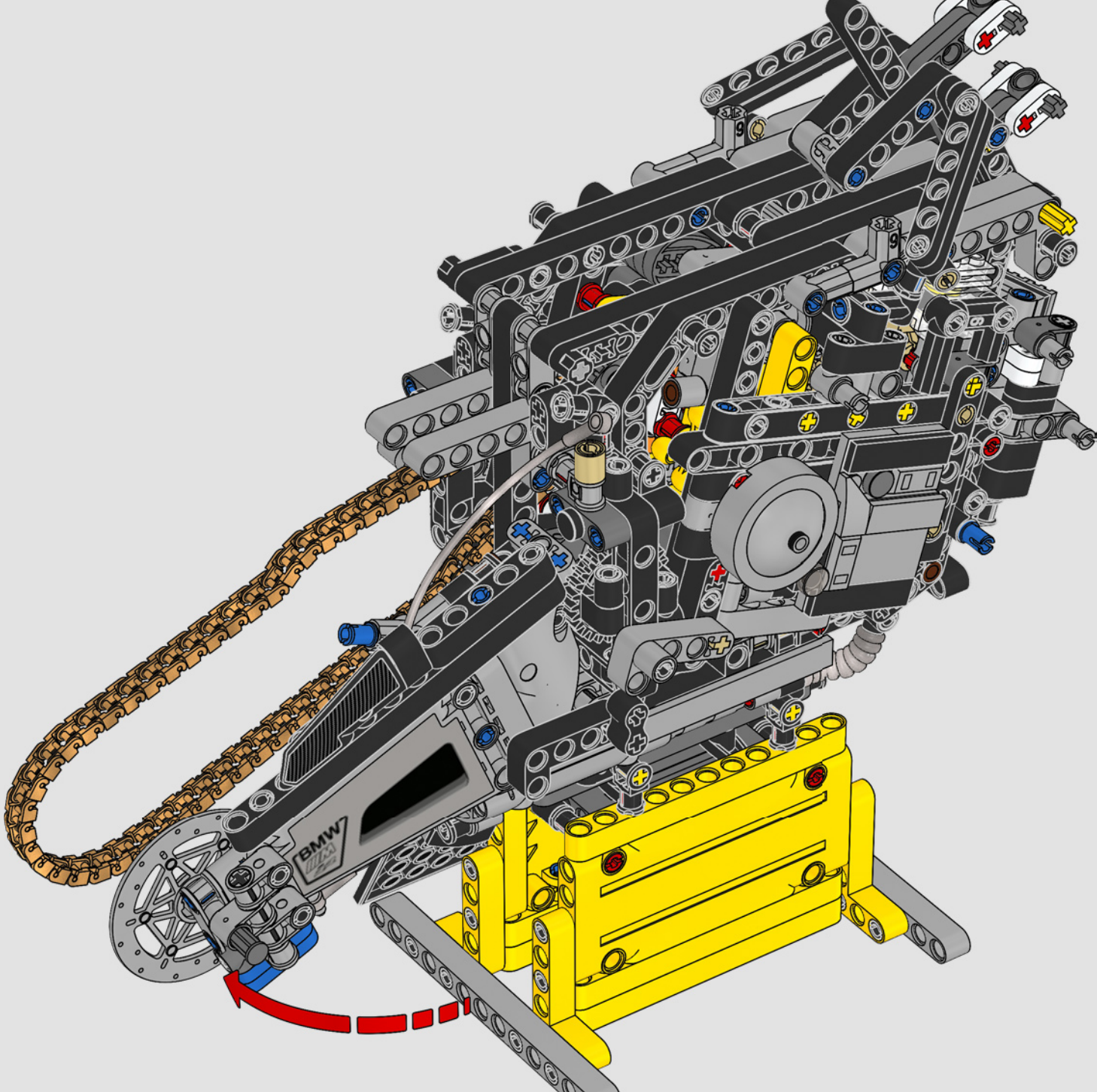

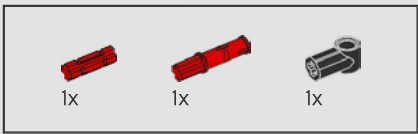

295

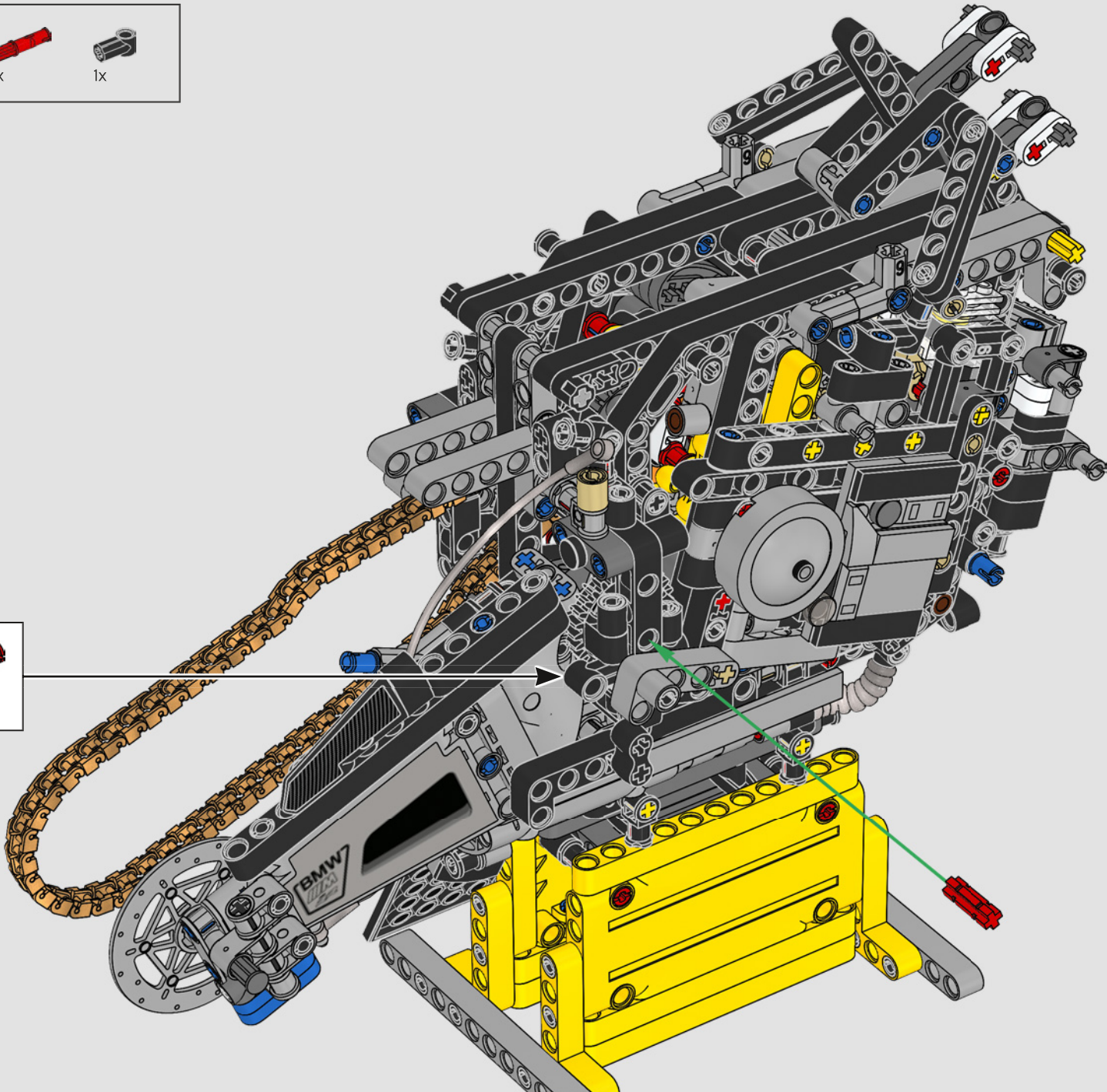
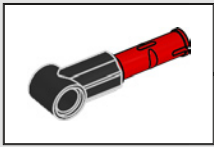

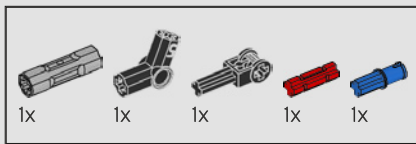

296

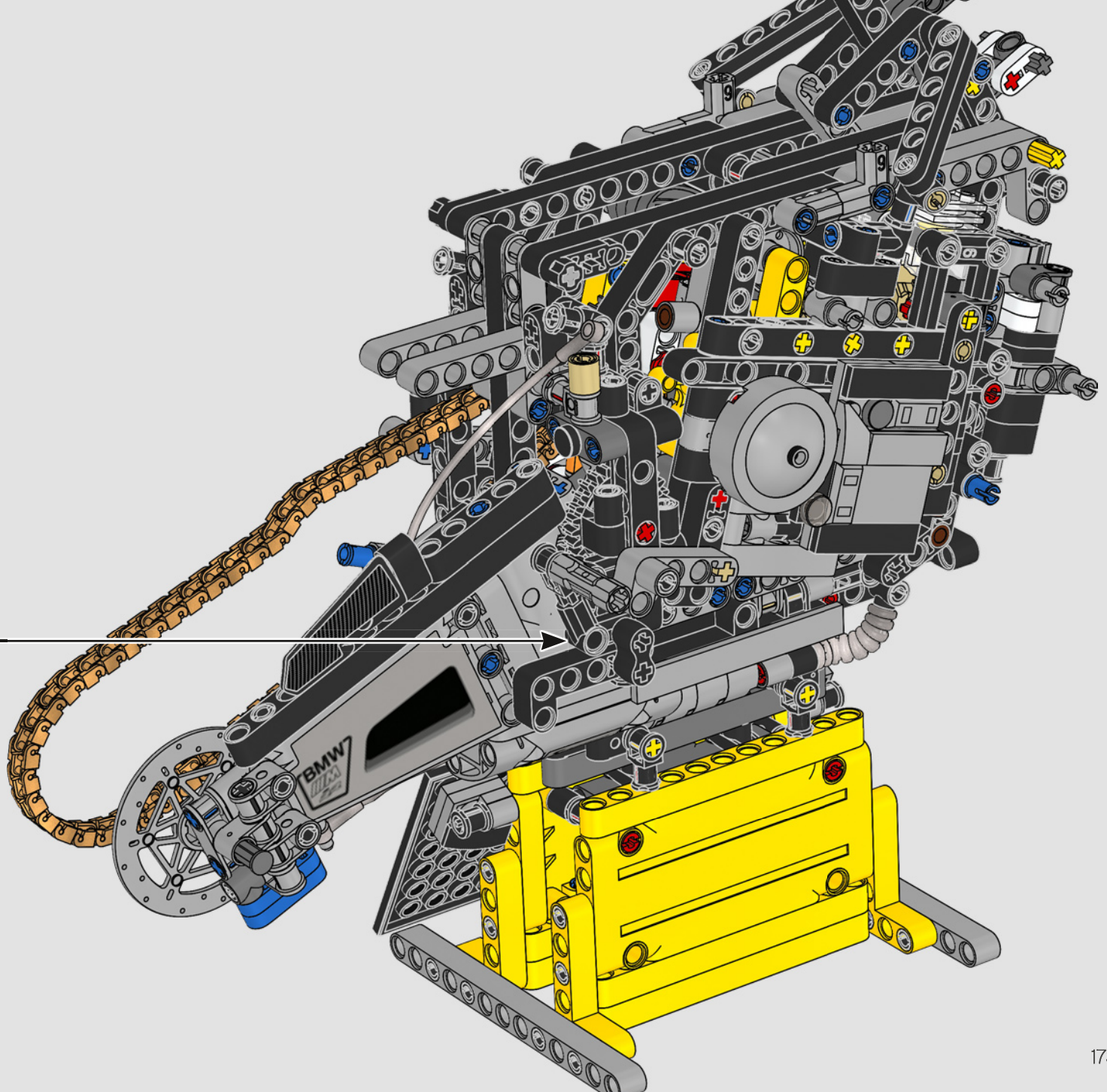
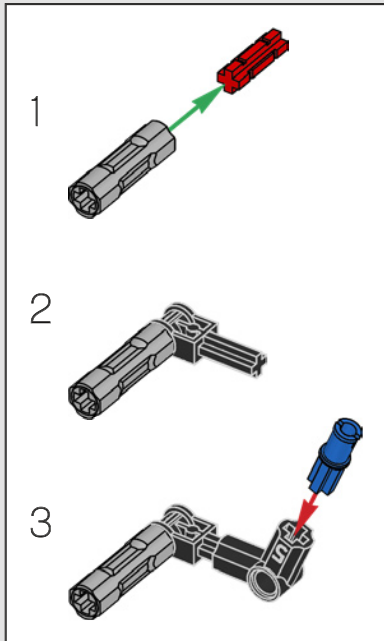

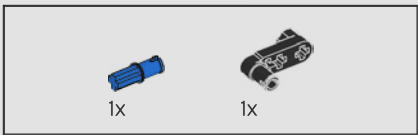

297

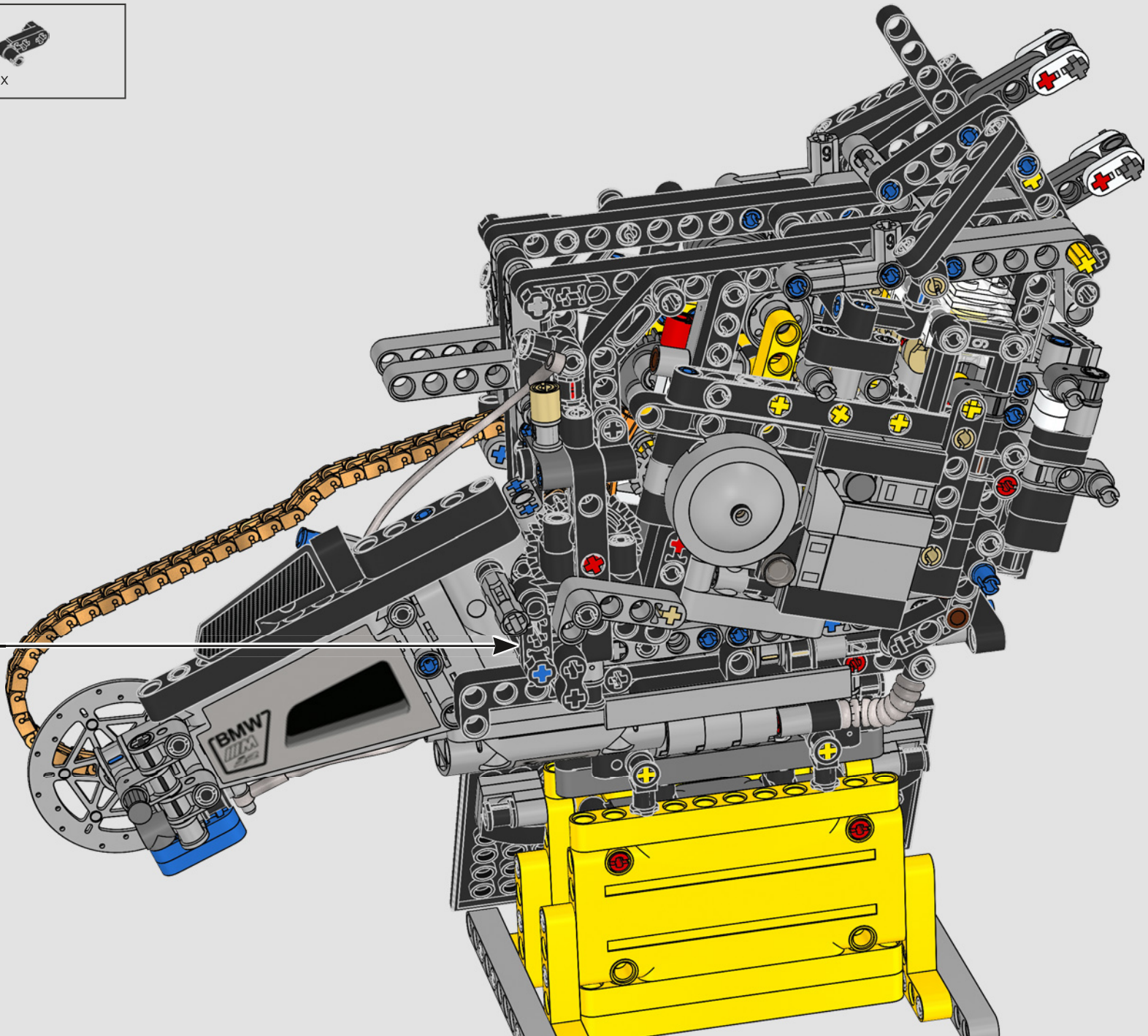
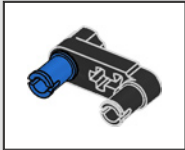

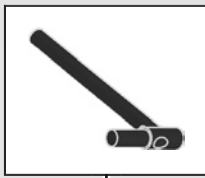
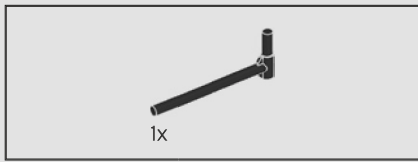

298

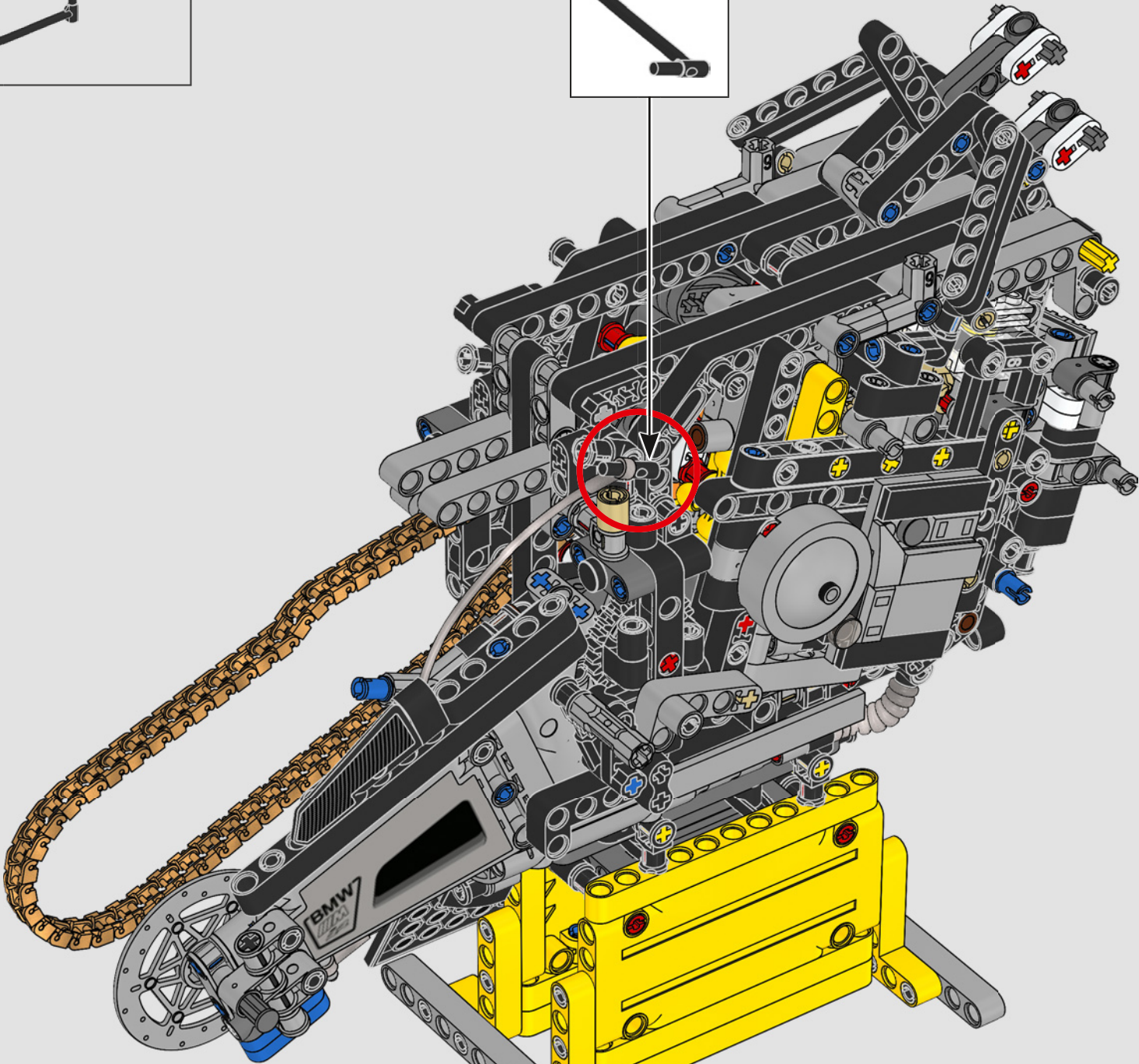

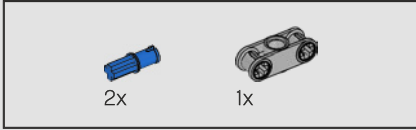
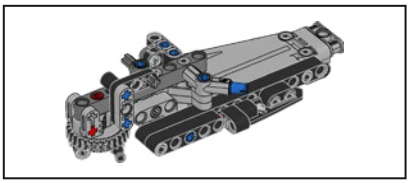

299

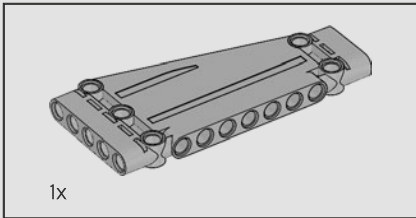
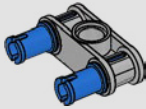

300

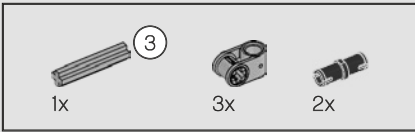
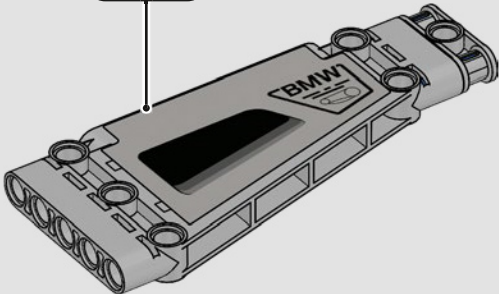

301

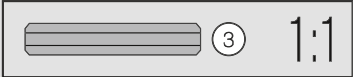
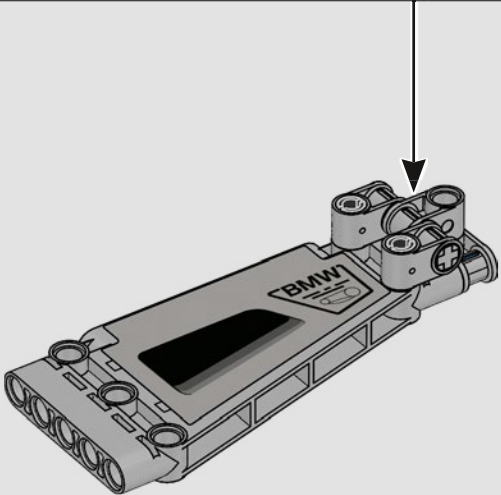
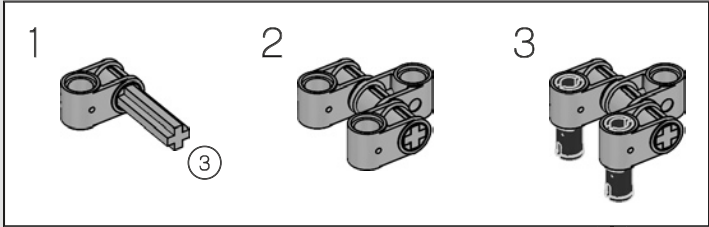

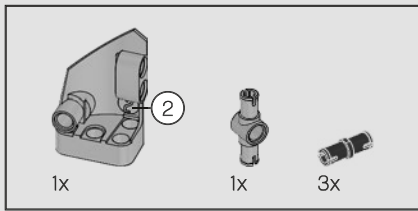

302

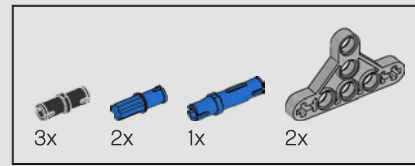
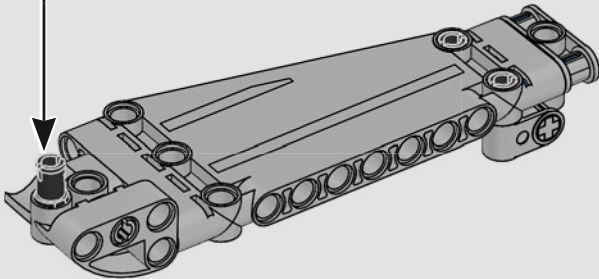
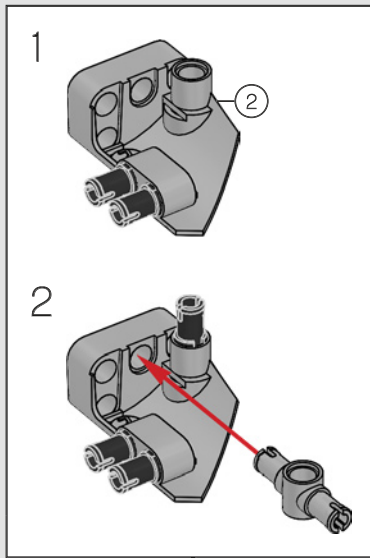

303

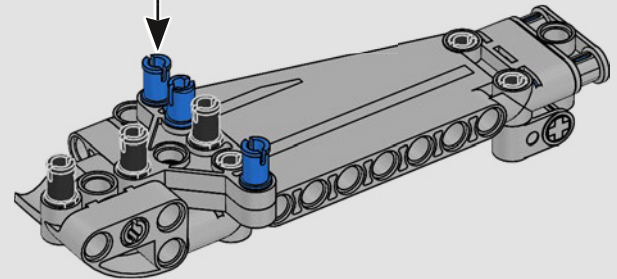
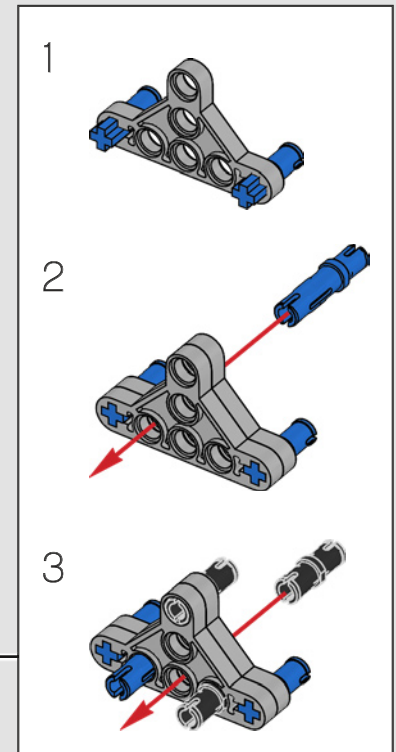

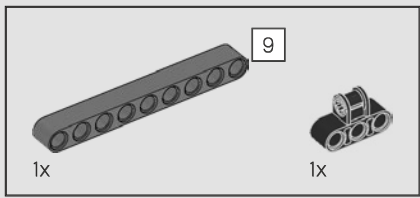

304

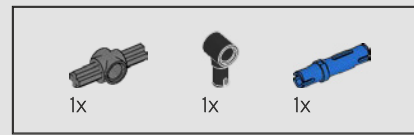
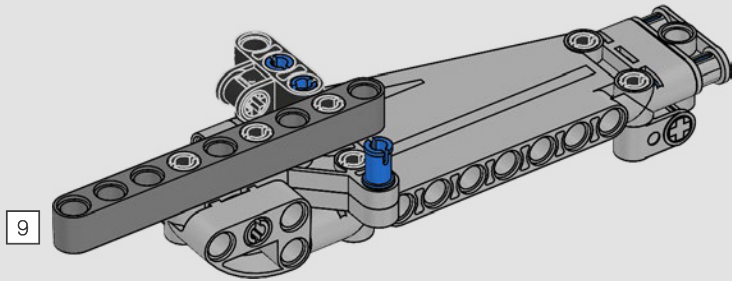

305

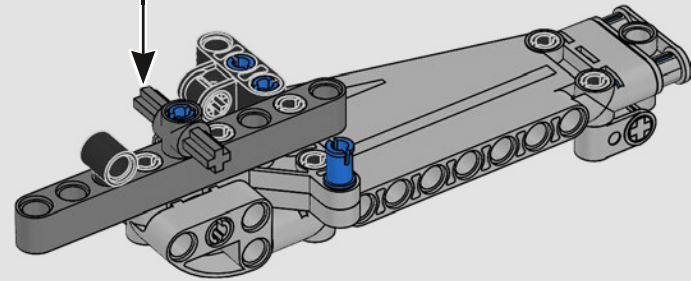
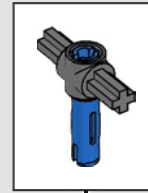

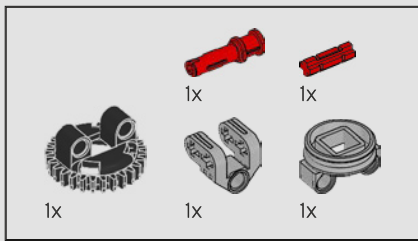

306

1

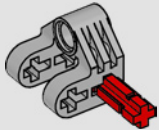

2

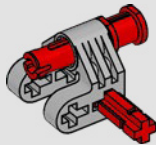

3

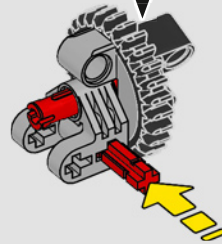

4

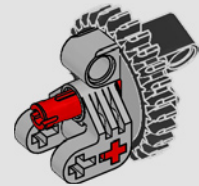

307

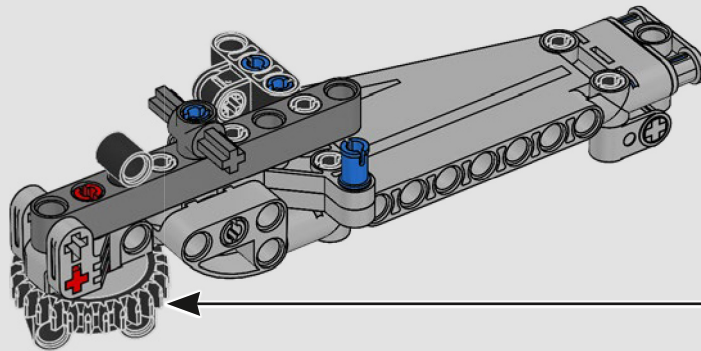

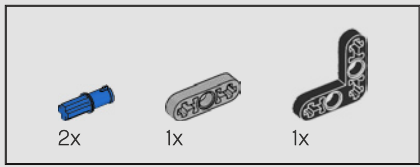

308

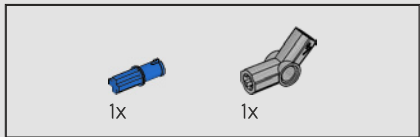
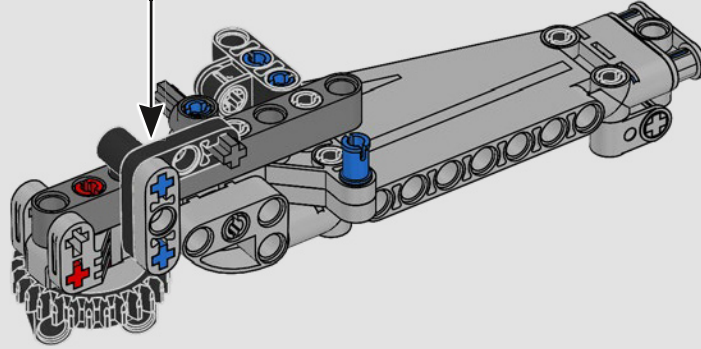
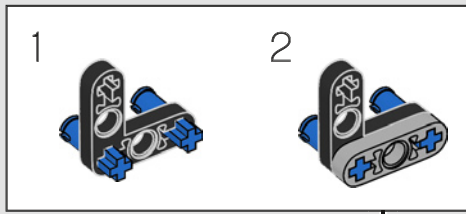

309

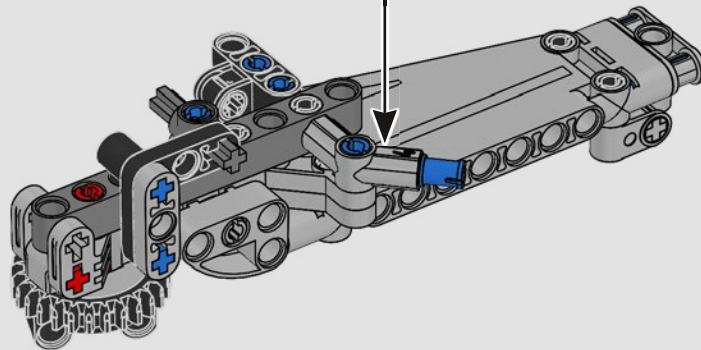
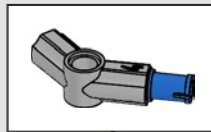

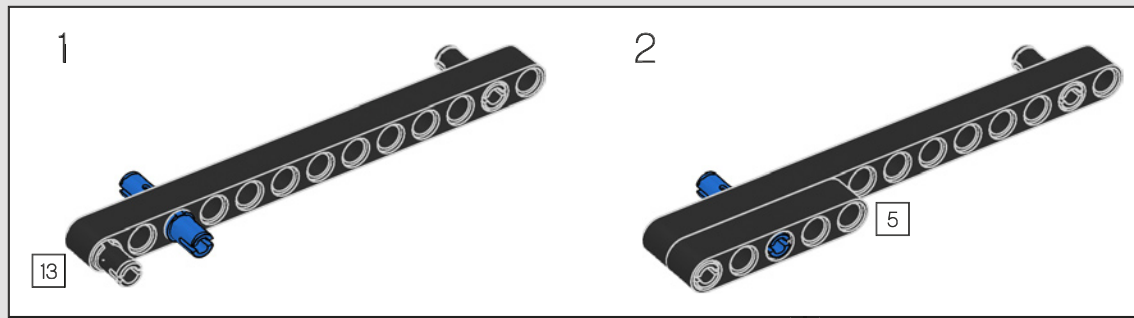
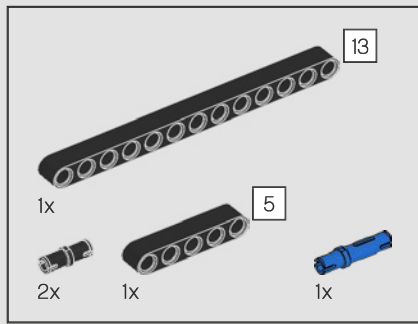

310

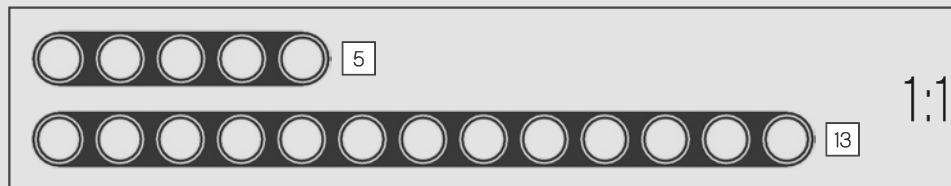
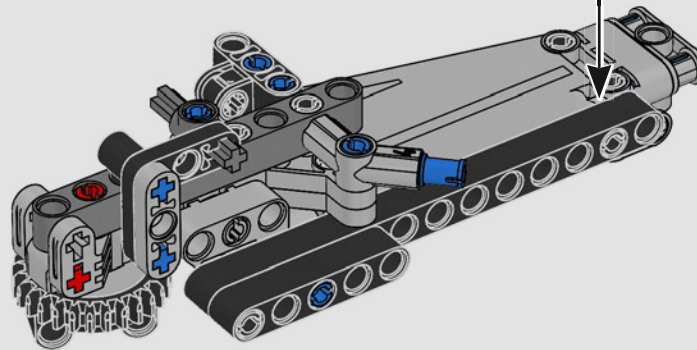

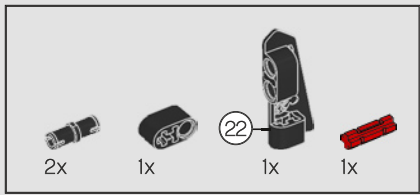

311

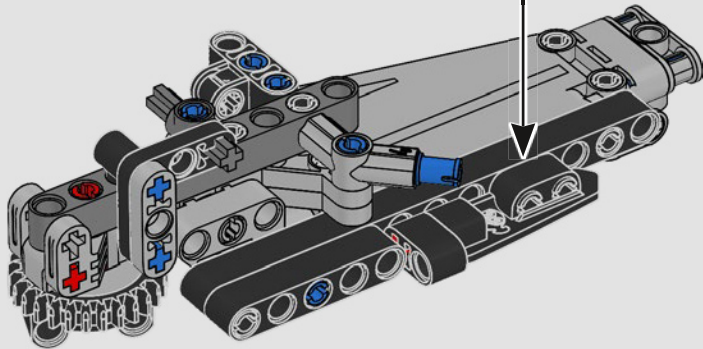
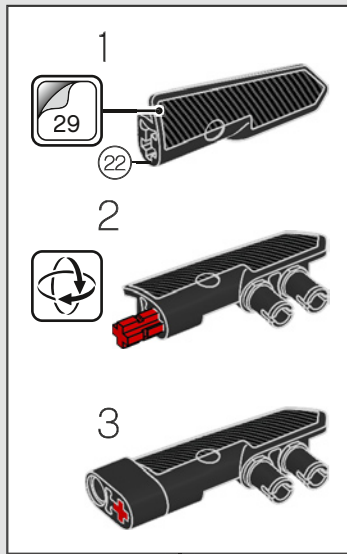

312

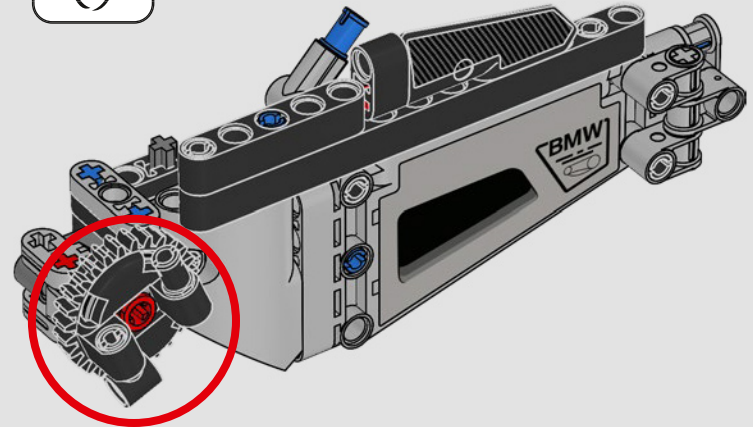

313

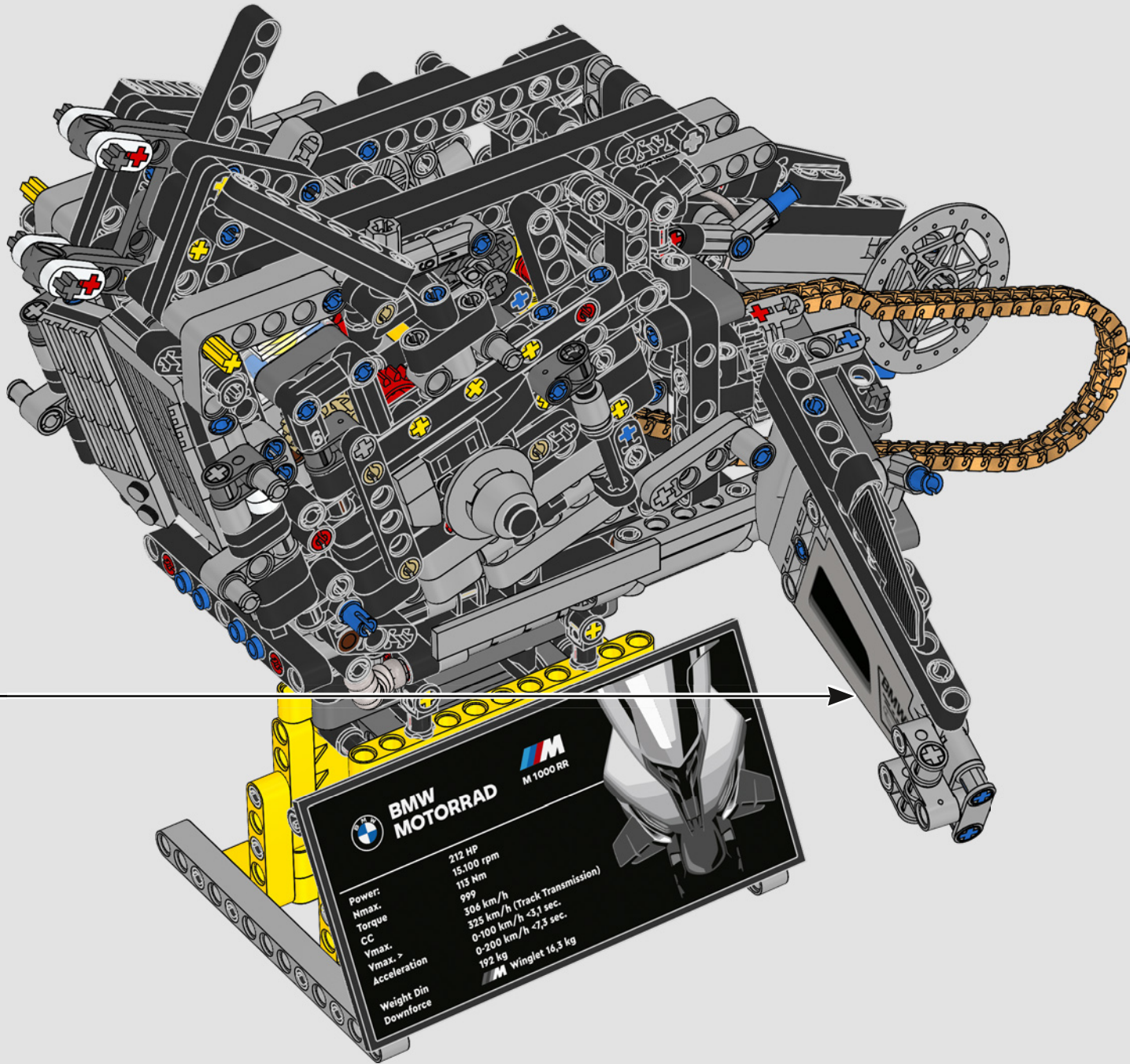

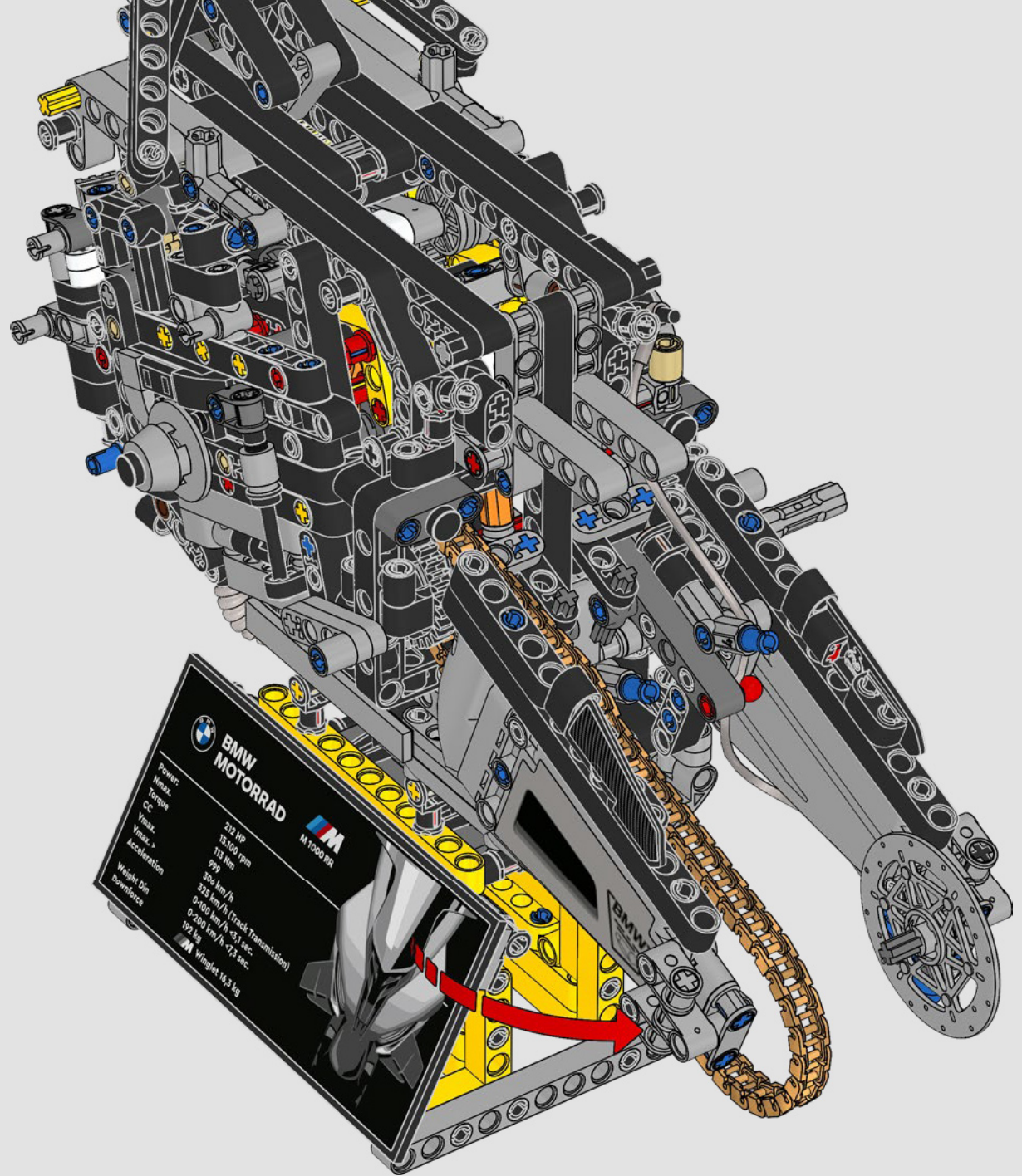
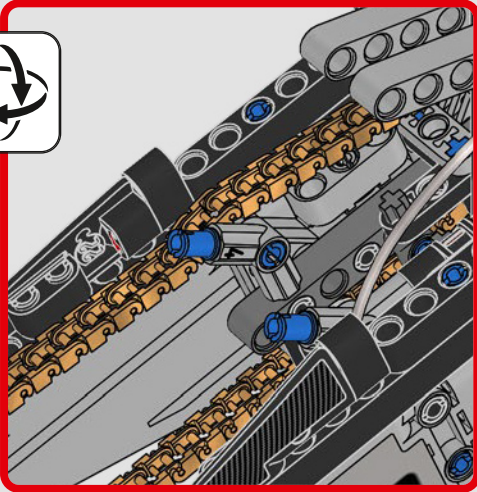

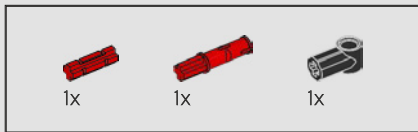

BMW MOTORRAD		M 1000 RR
Power:	212 HP	
Max. Torque:	15,100 rpm	
CC:	113 Nm	
Max. Vmax.:	999	
Acceleration:	356 km/h	
Weight (Dry):	323 km/h (Track Transmission)	
Downforce:	0-100 km/h < 3,1 sec.	
	0-200 km/h < 7,3 sec.	
	192 kg	
	Winglet 16,3 kg	

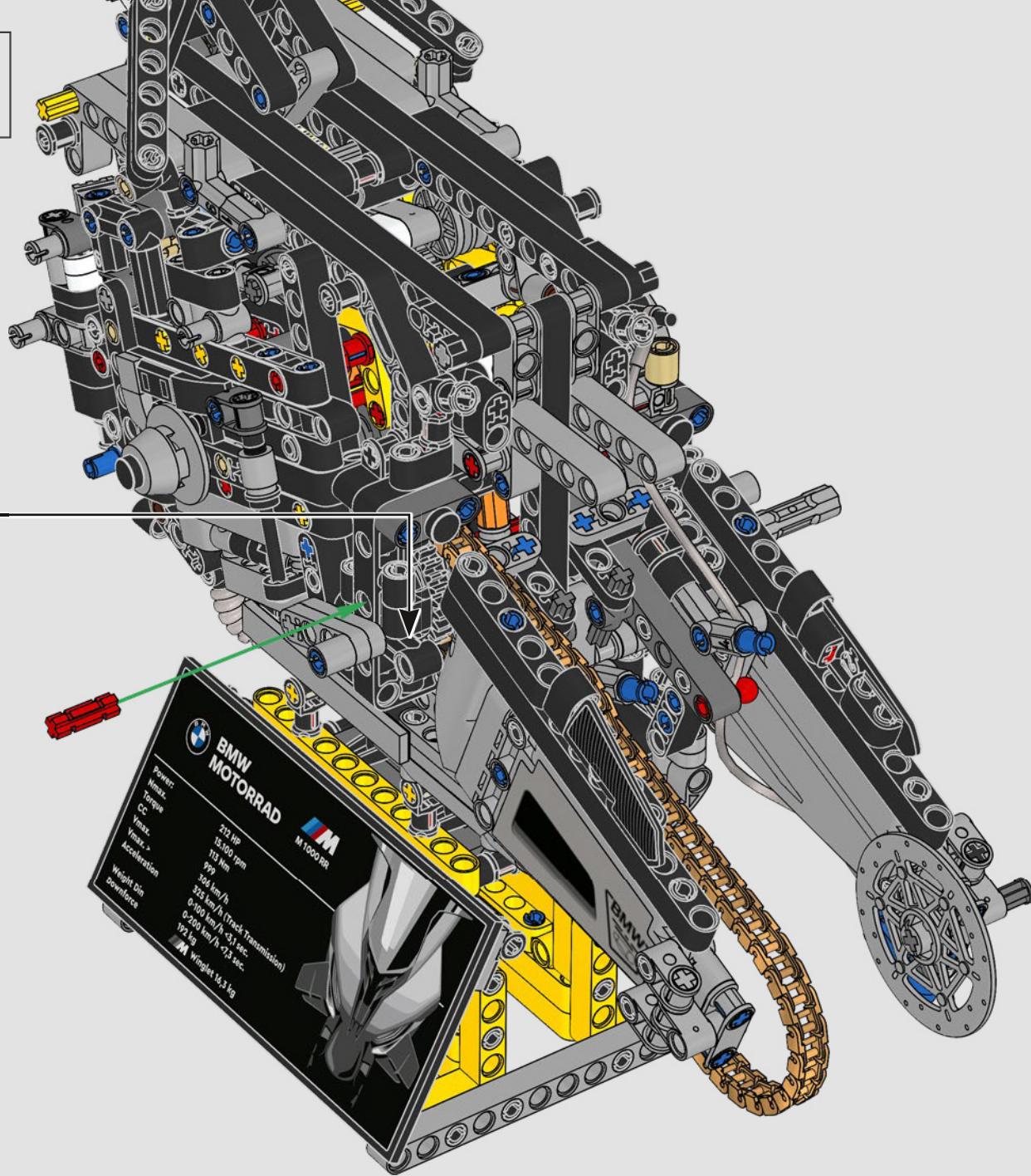
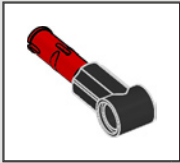

315



BMW MOTORRAD  **M 1000 RR**

Power: 212 hp
 Max. Torque: 15.10 rpm
 CC: 112 Nm
 Vmax: 999
 Vmax + Acceleration: 304 km/h
 Weight (Dry): 323 km/h (Track Transmission)
 Power/Weight: 0-100 km/h < 3.1 sec.
 0-200 km/h < 11.3 sec.
 192 kg
 Wetweight 18.3 kg

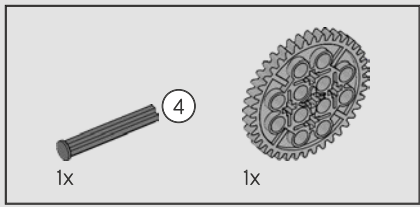

316

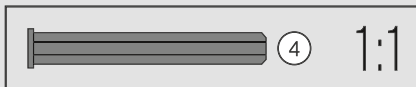
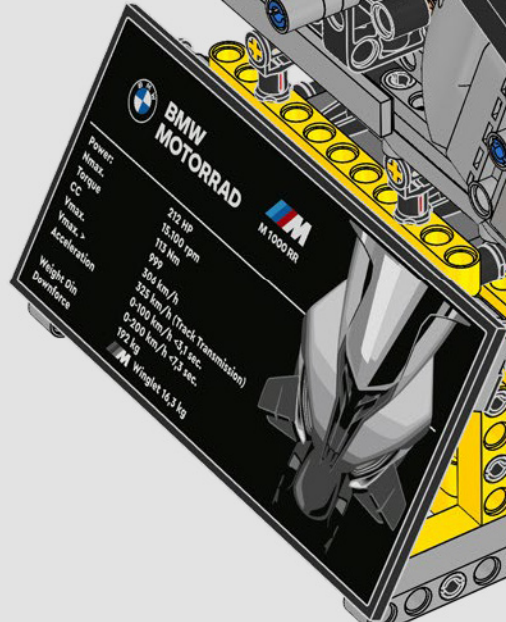
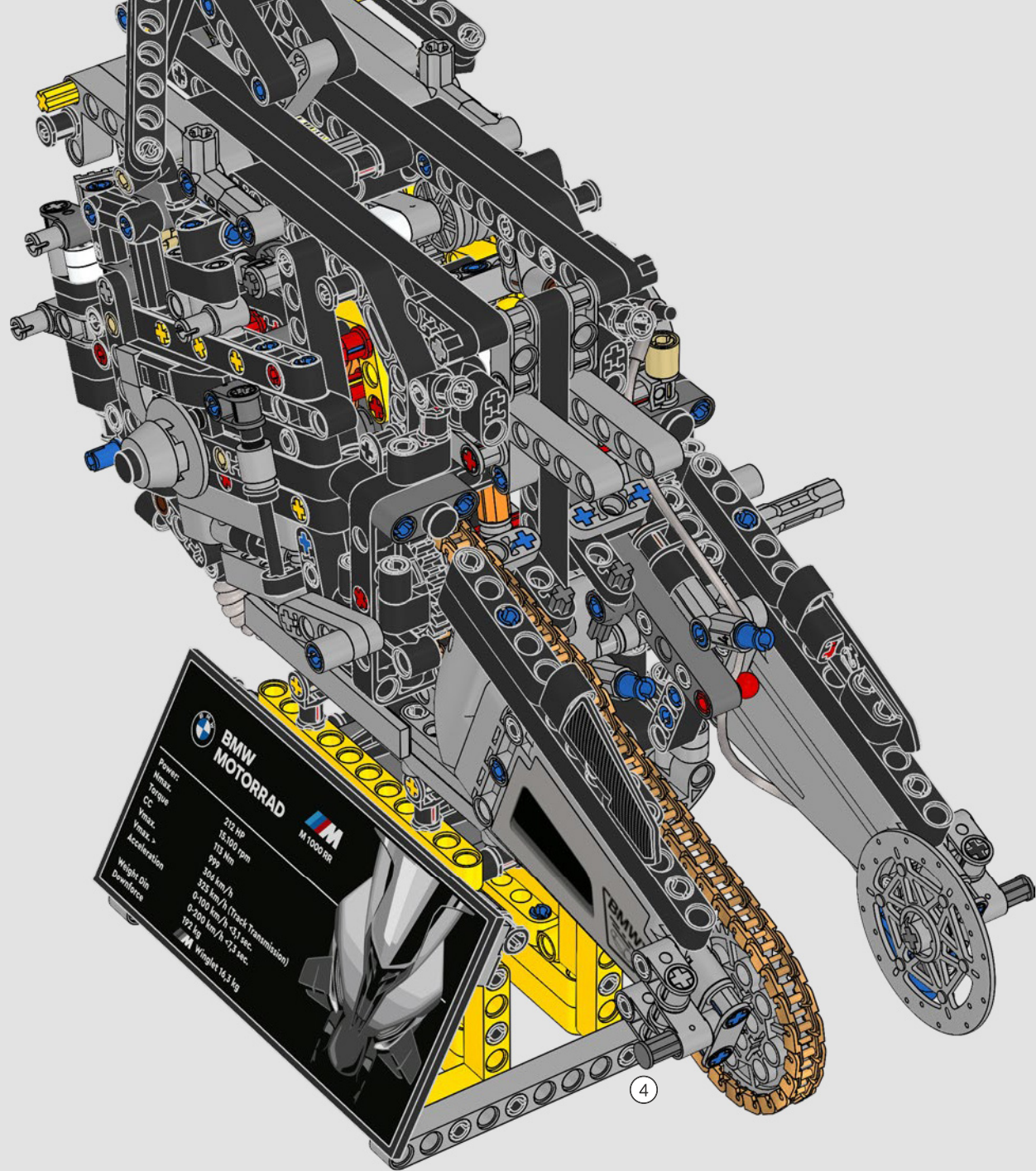

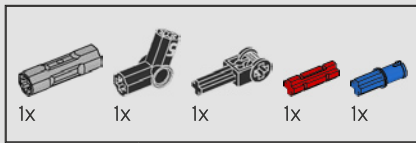

317

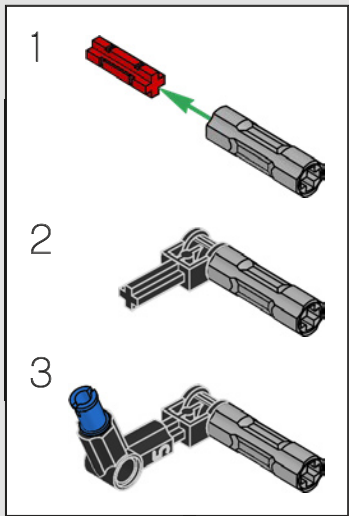
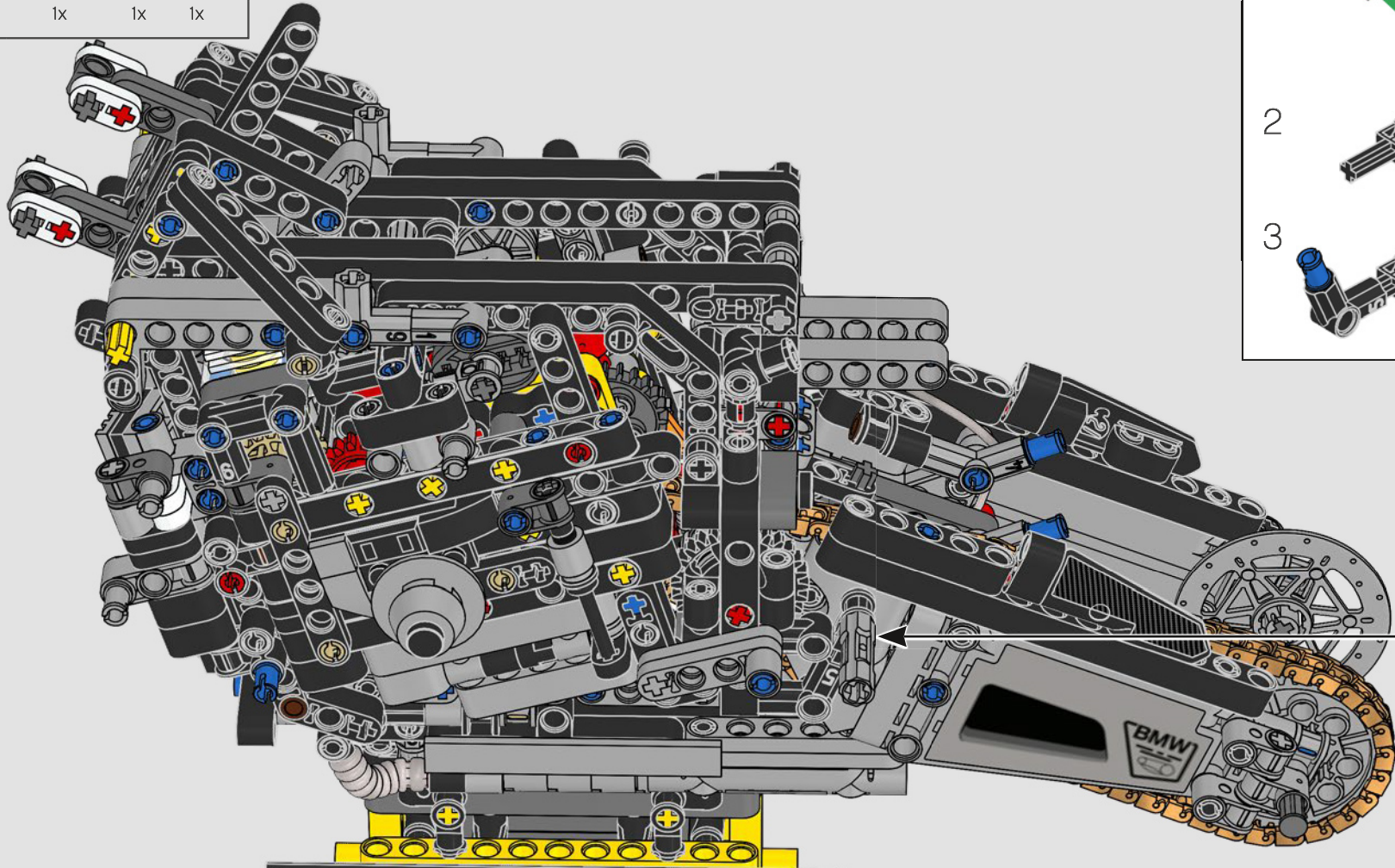



BMW
MOTORRAD





M 1000 RR

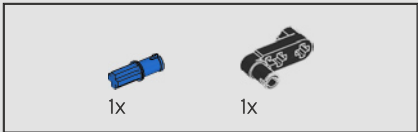

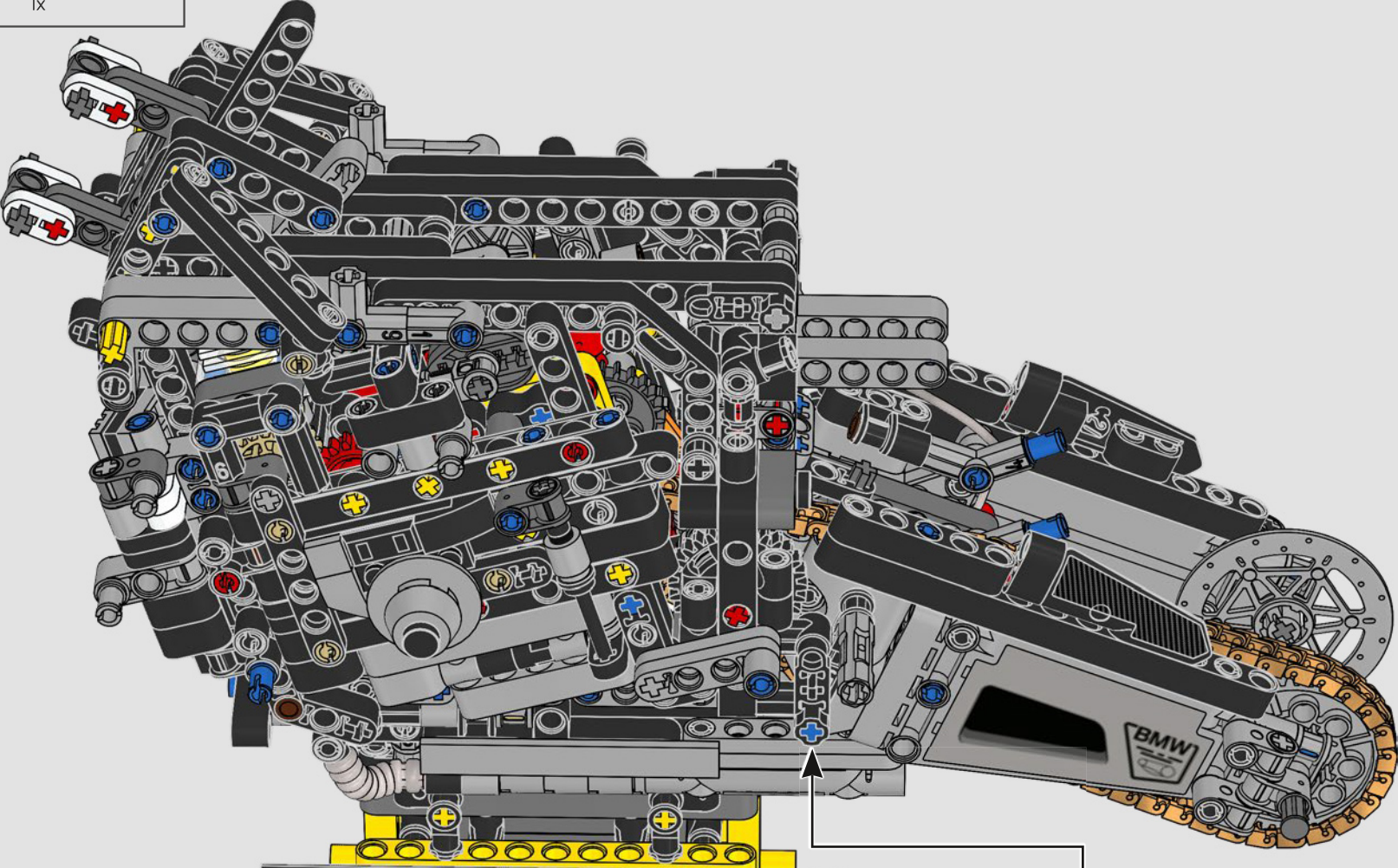

318





BMW
MOTORRAD



M
1000 RR

Power: 212 HP

Nmax. 15.100 rpm

Torque 113 Nm

CC 999

Vmax. 306 km/h

Vmax. > 325 km/h (Track Transmission)

Acceleration 0-100 km/h <3,1 sec.
0-200 km/h <7,3 sec.

Weight Din 192 kg

Downforce  Winglet 16,3 kg

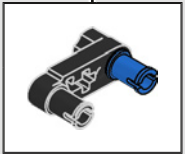

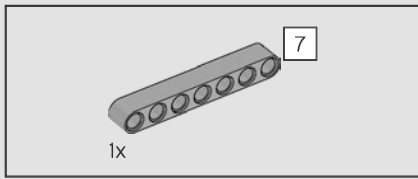
319



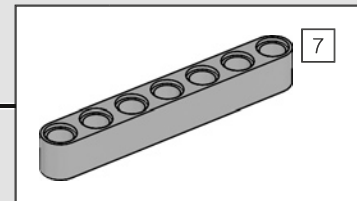
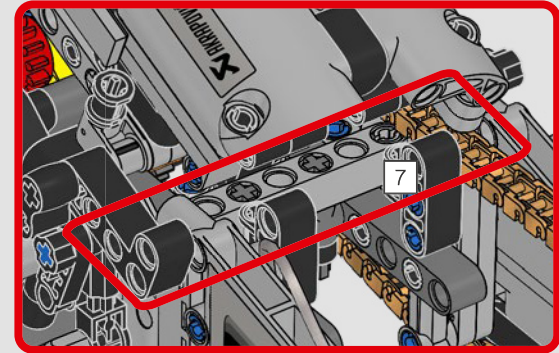
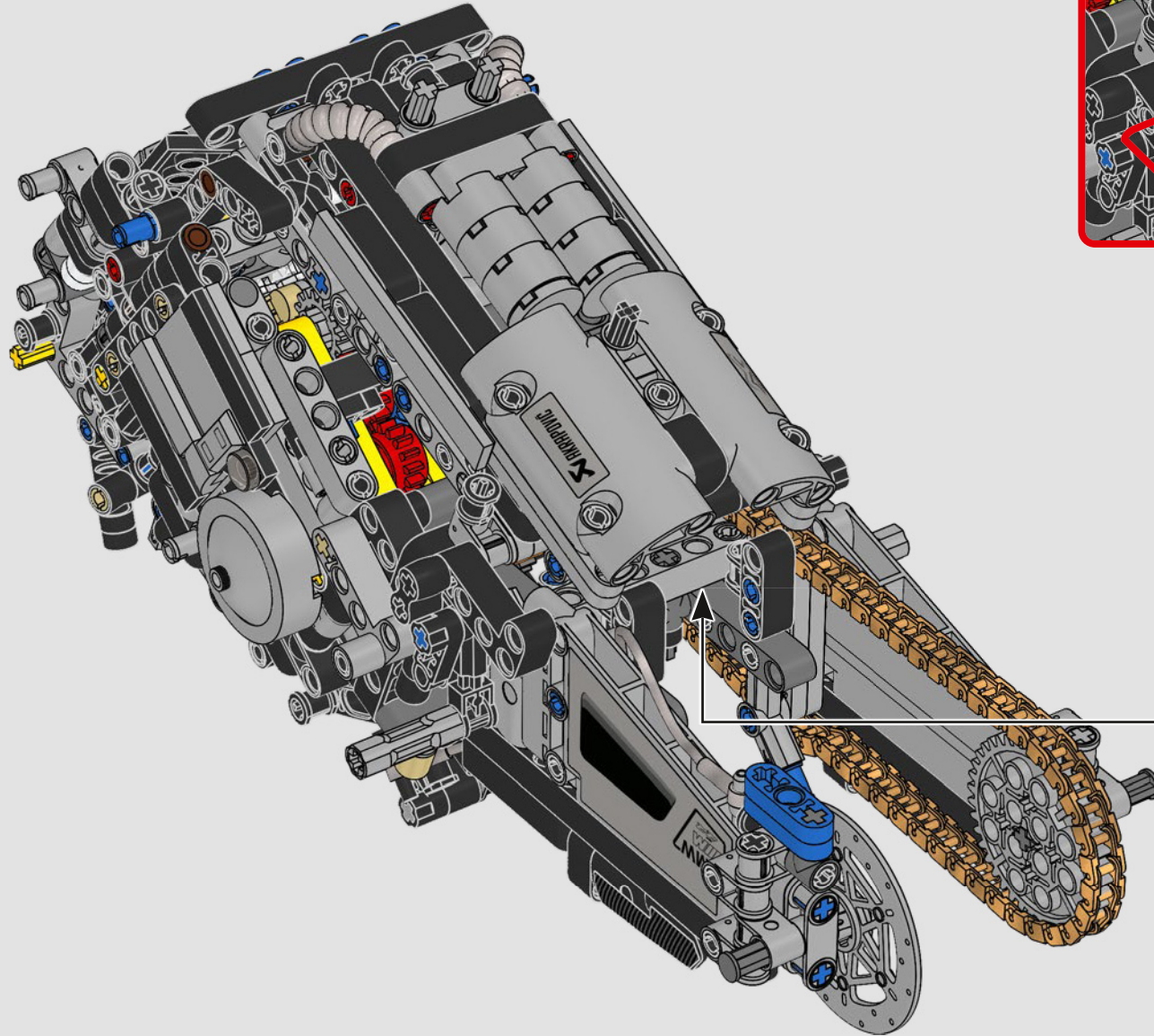

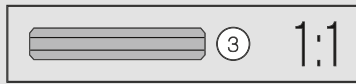
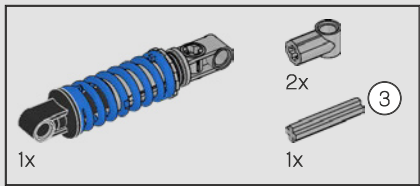
320

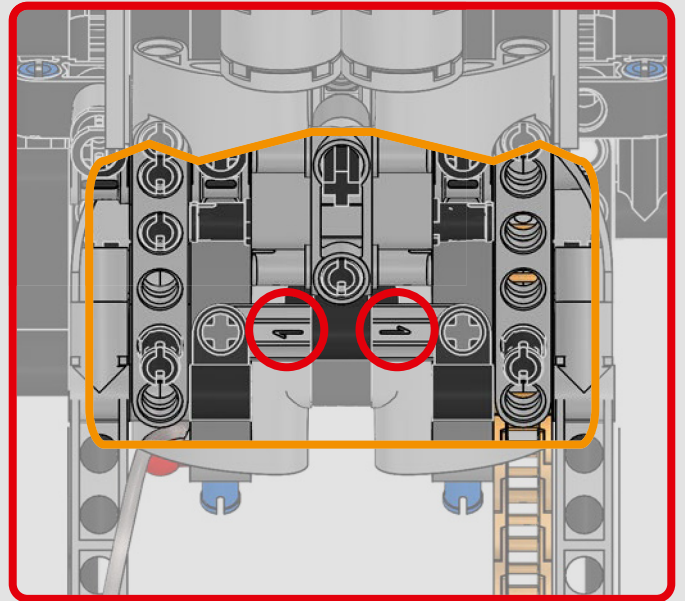
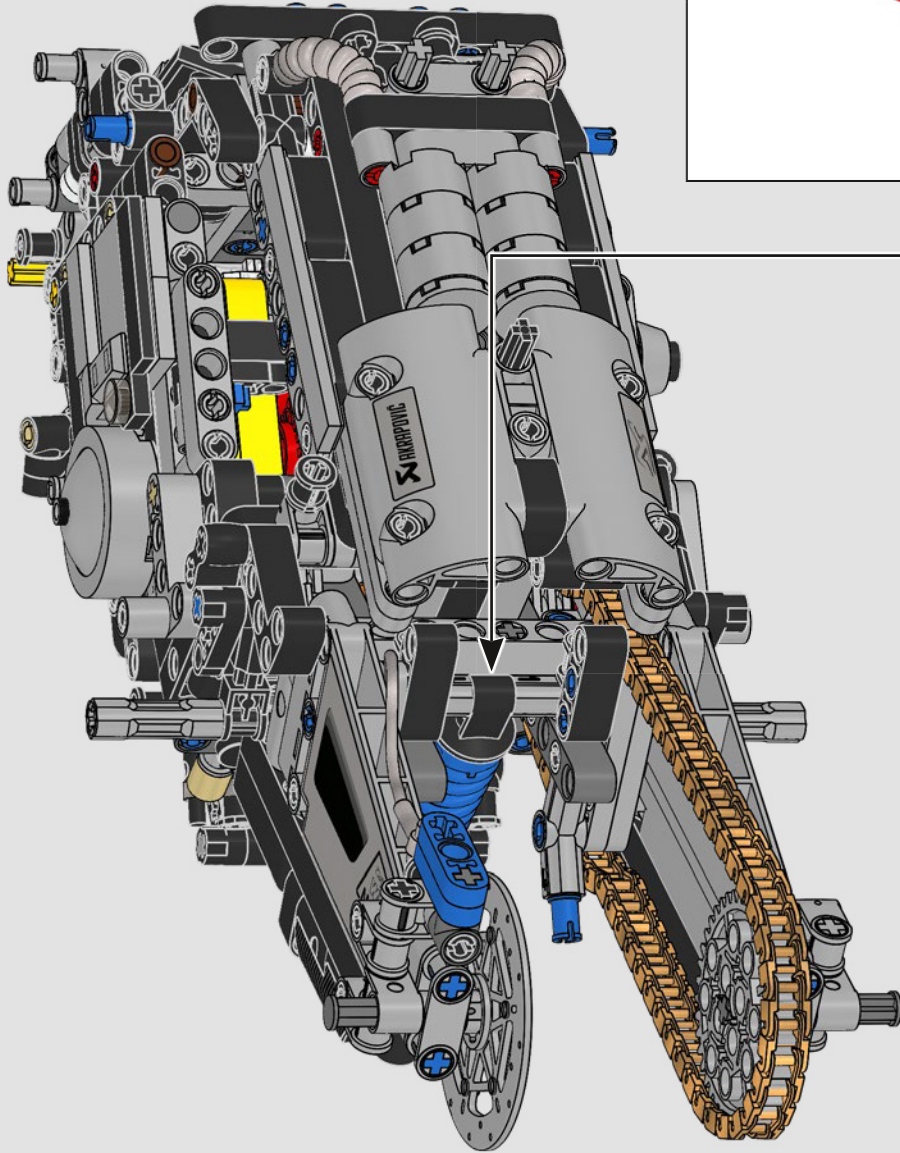
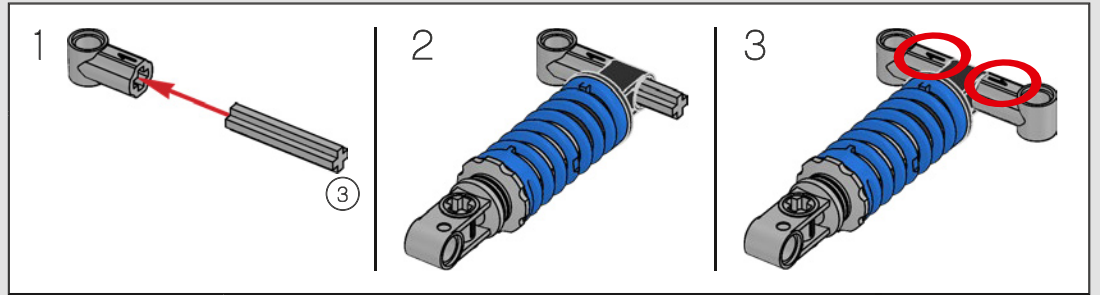

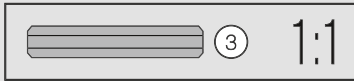
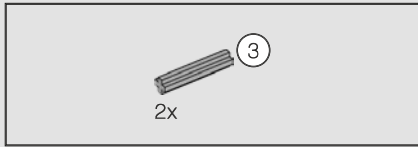

321

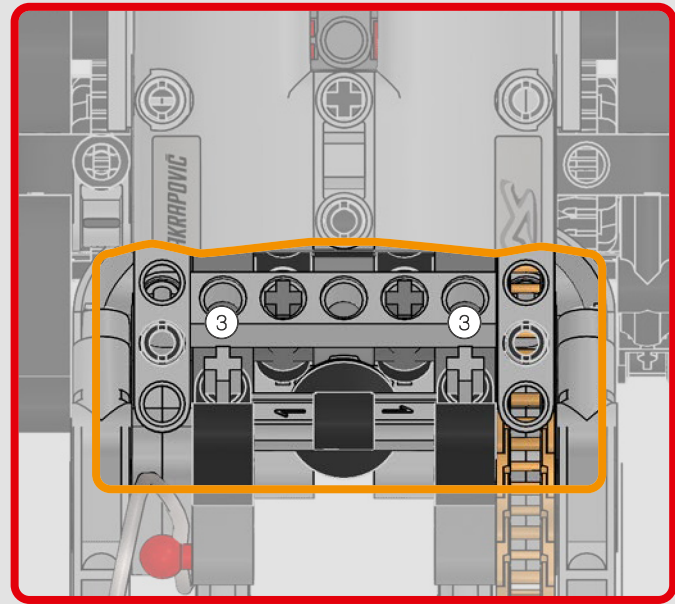
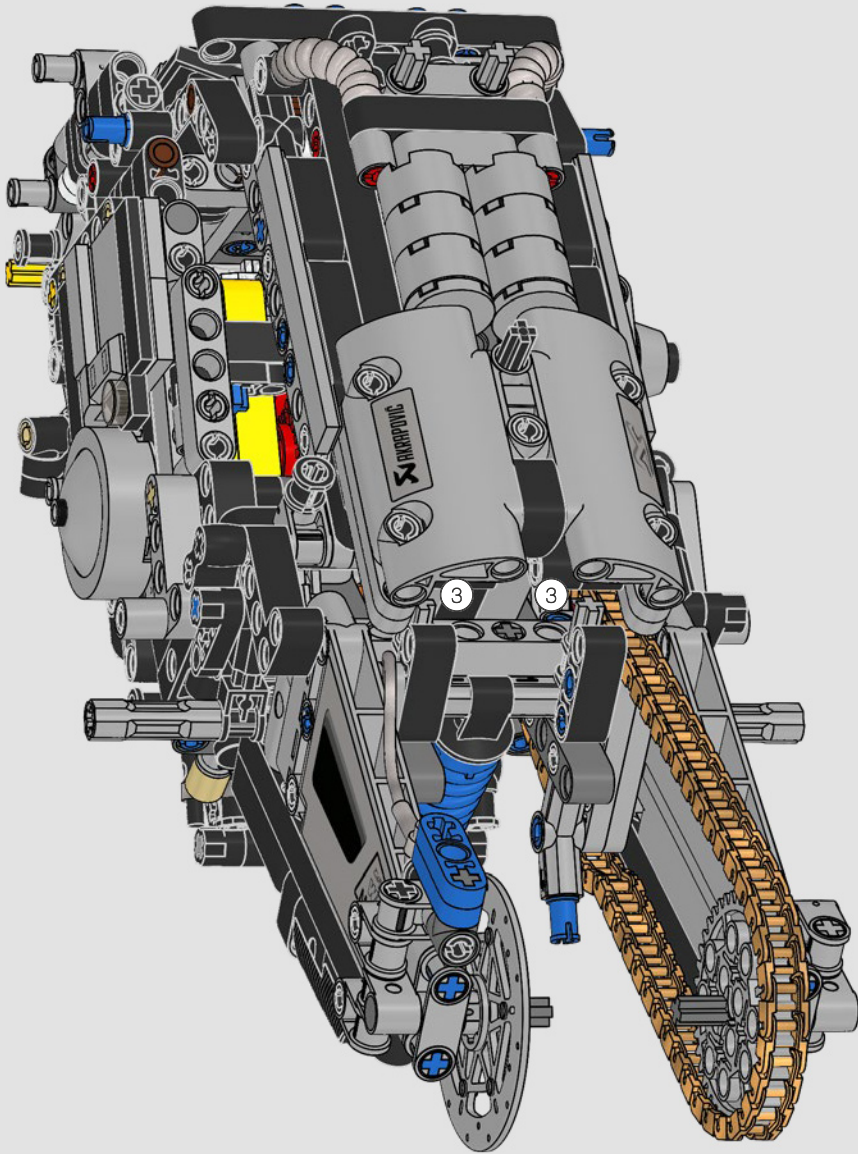

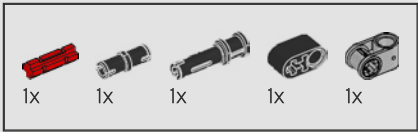

322

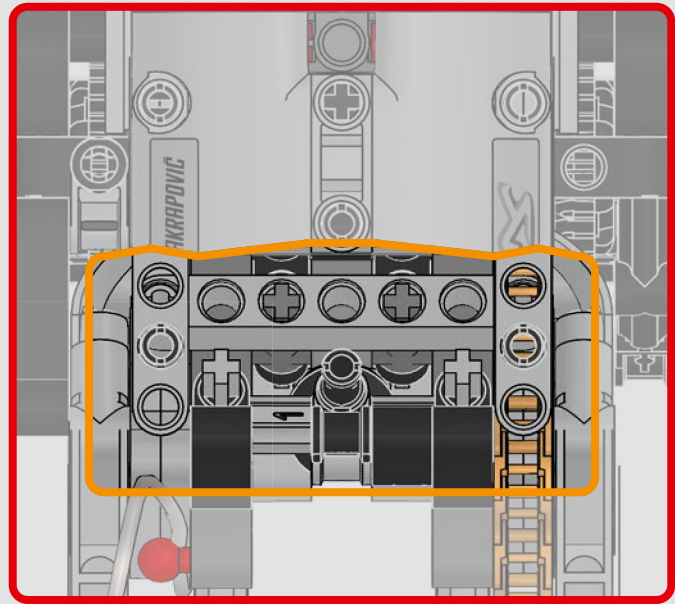
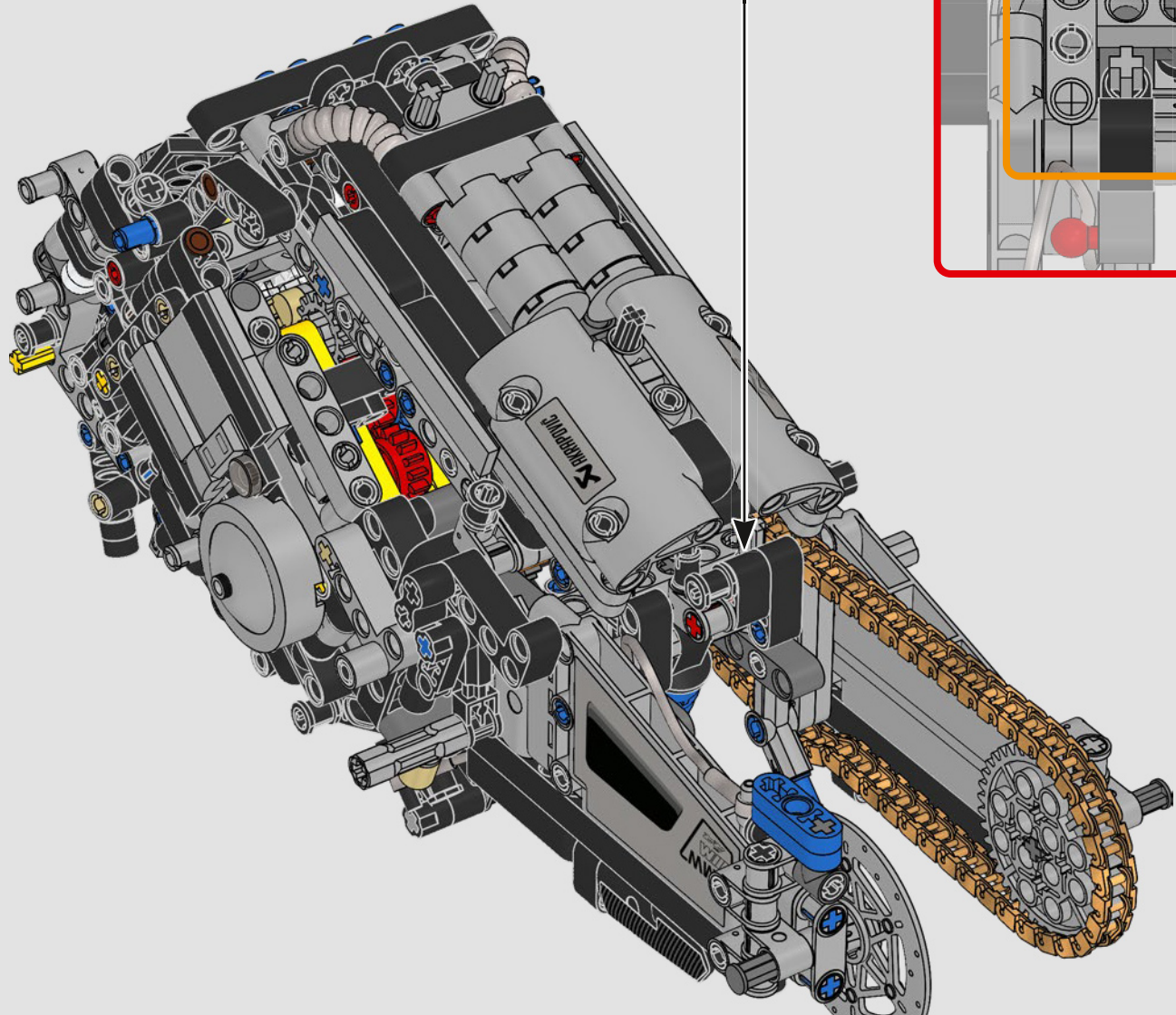
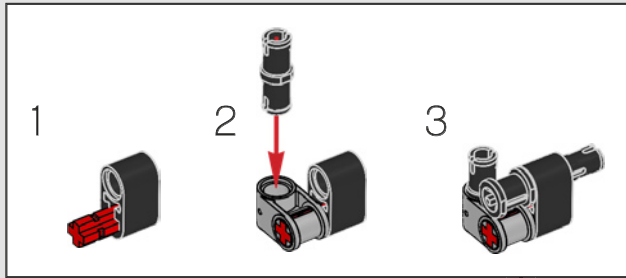

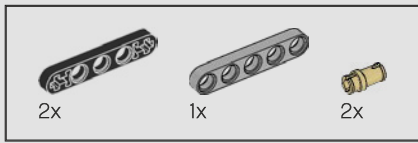

323

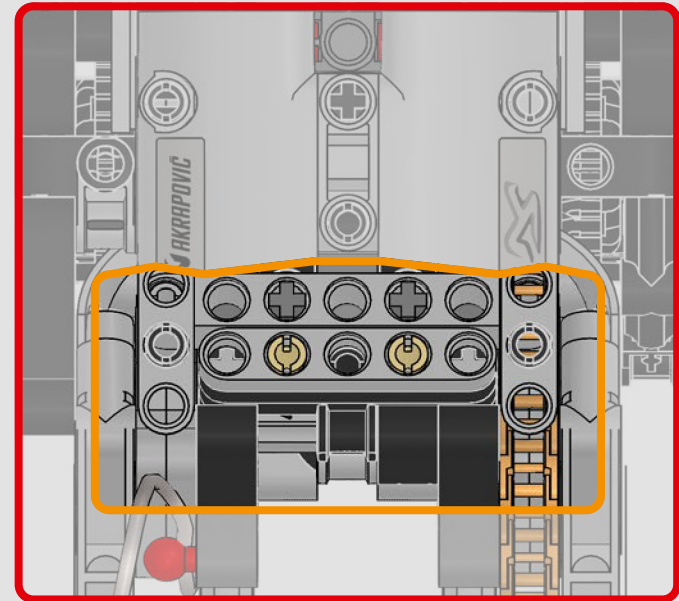
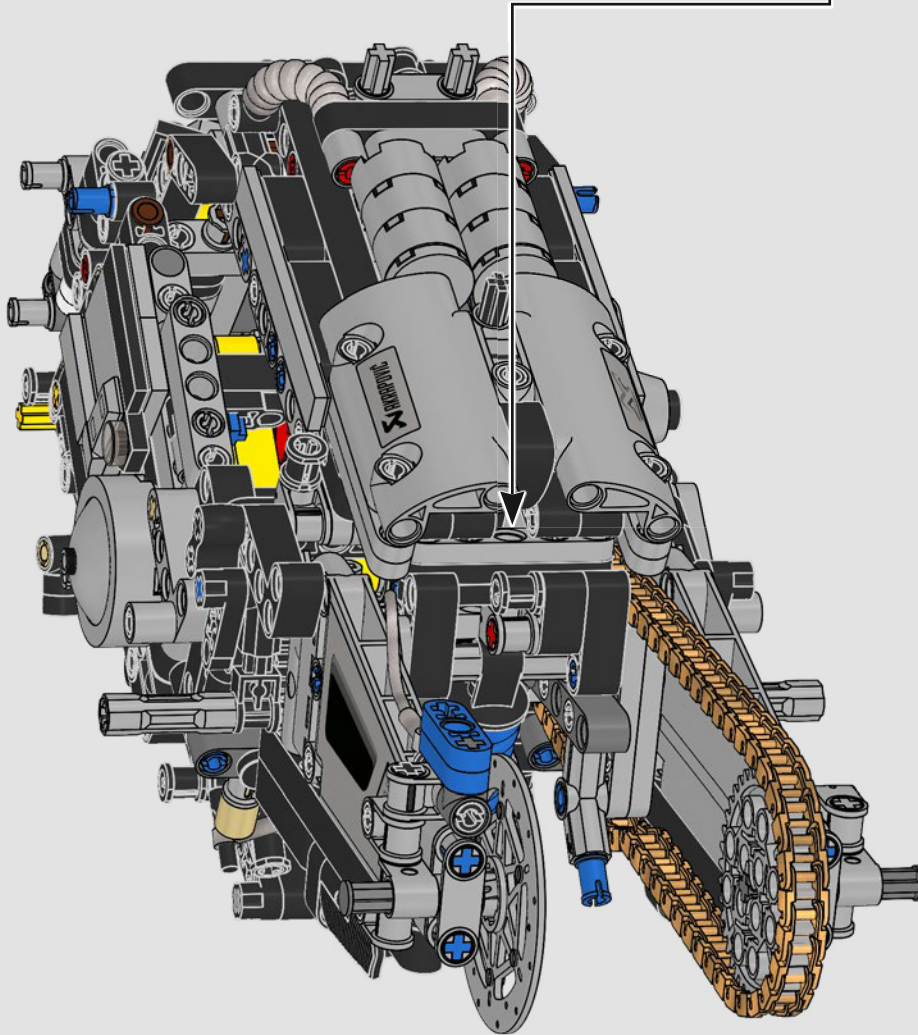
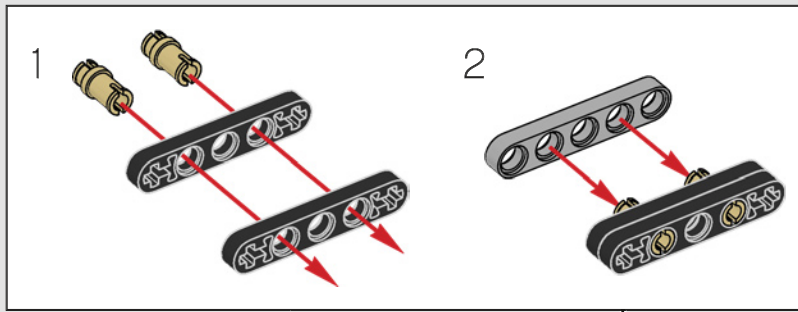

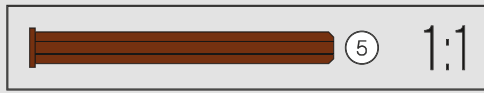
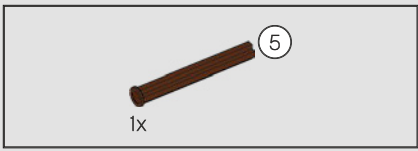

324

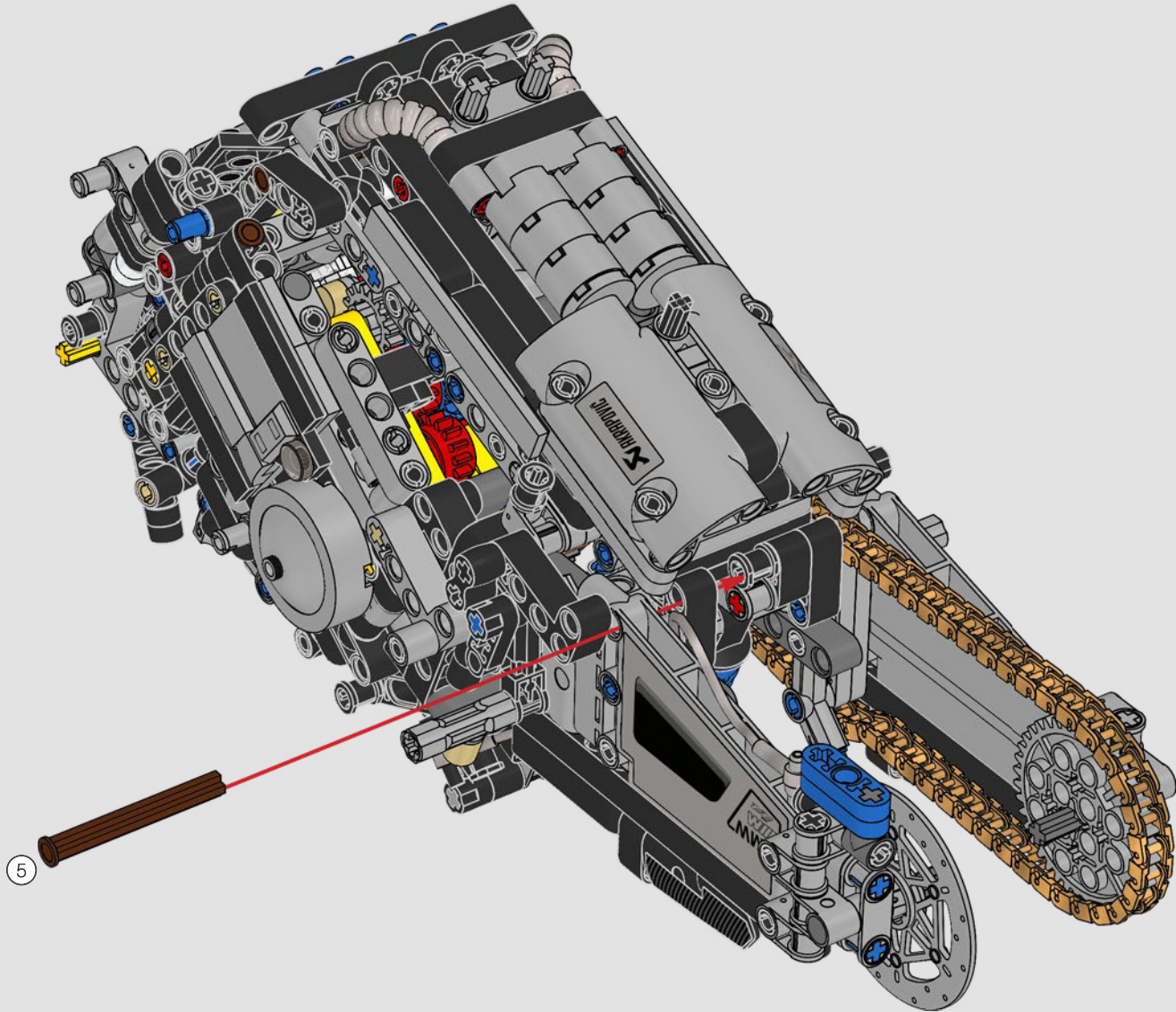

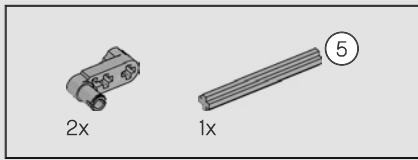

325

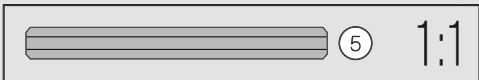
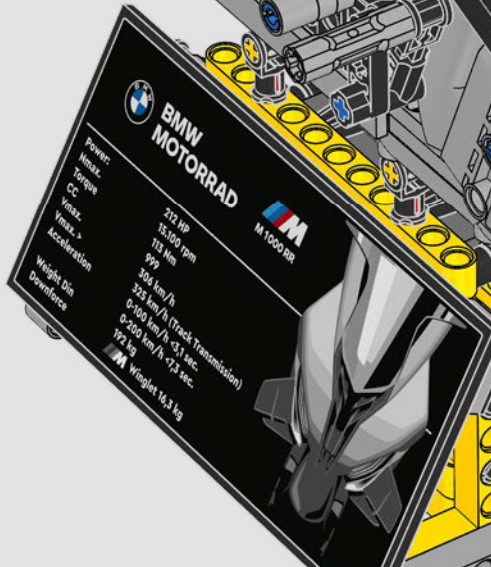
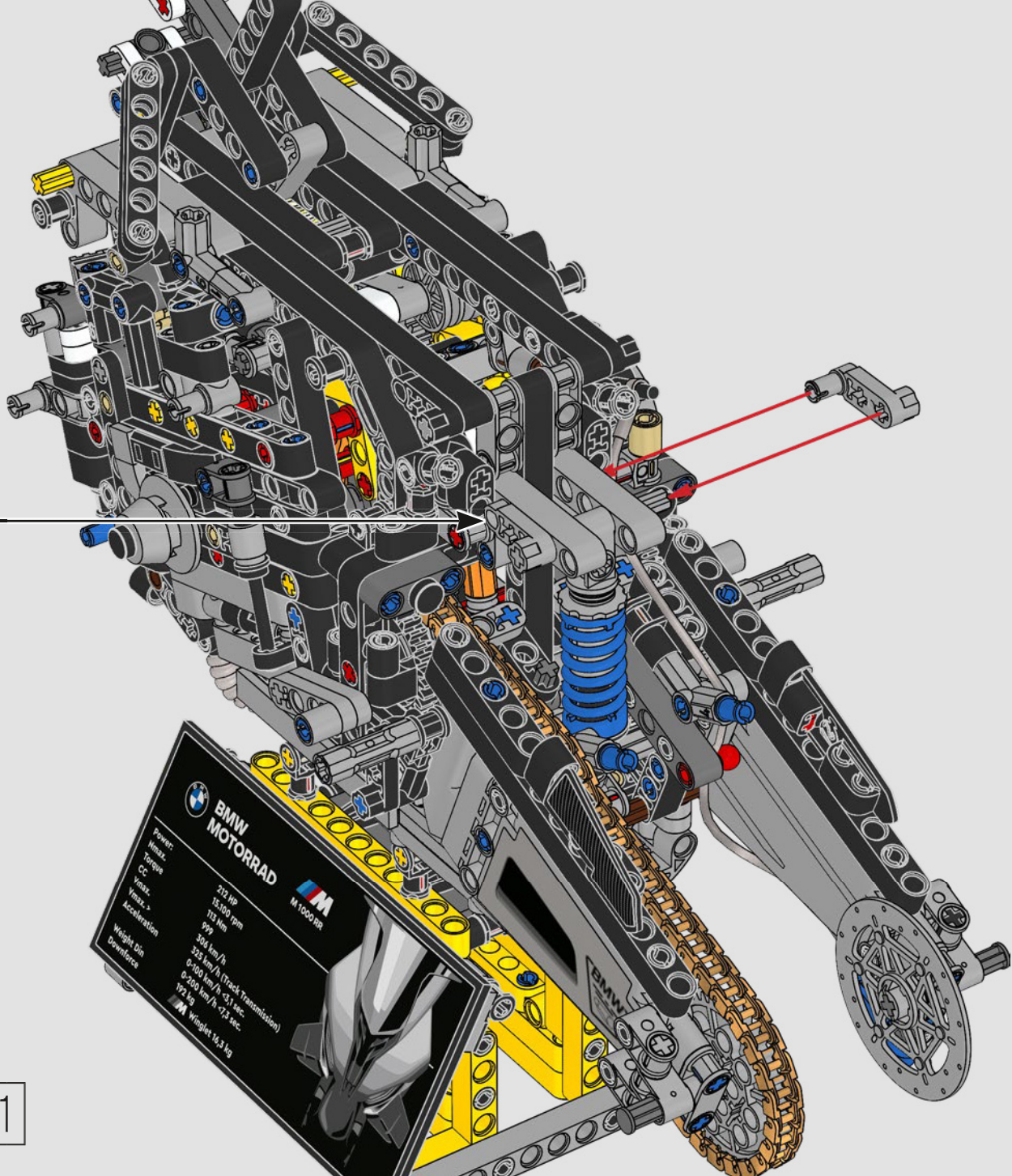
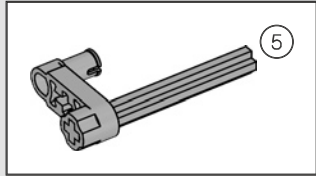

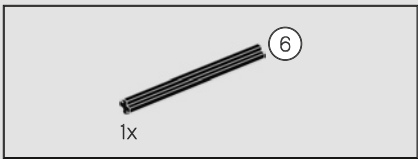

326

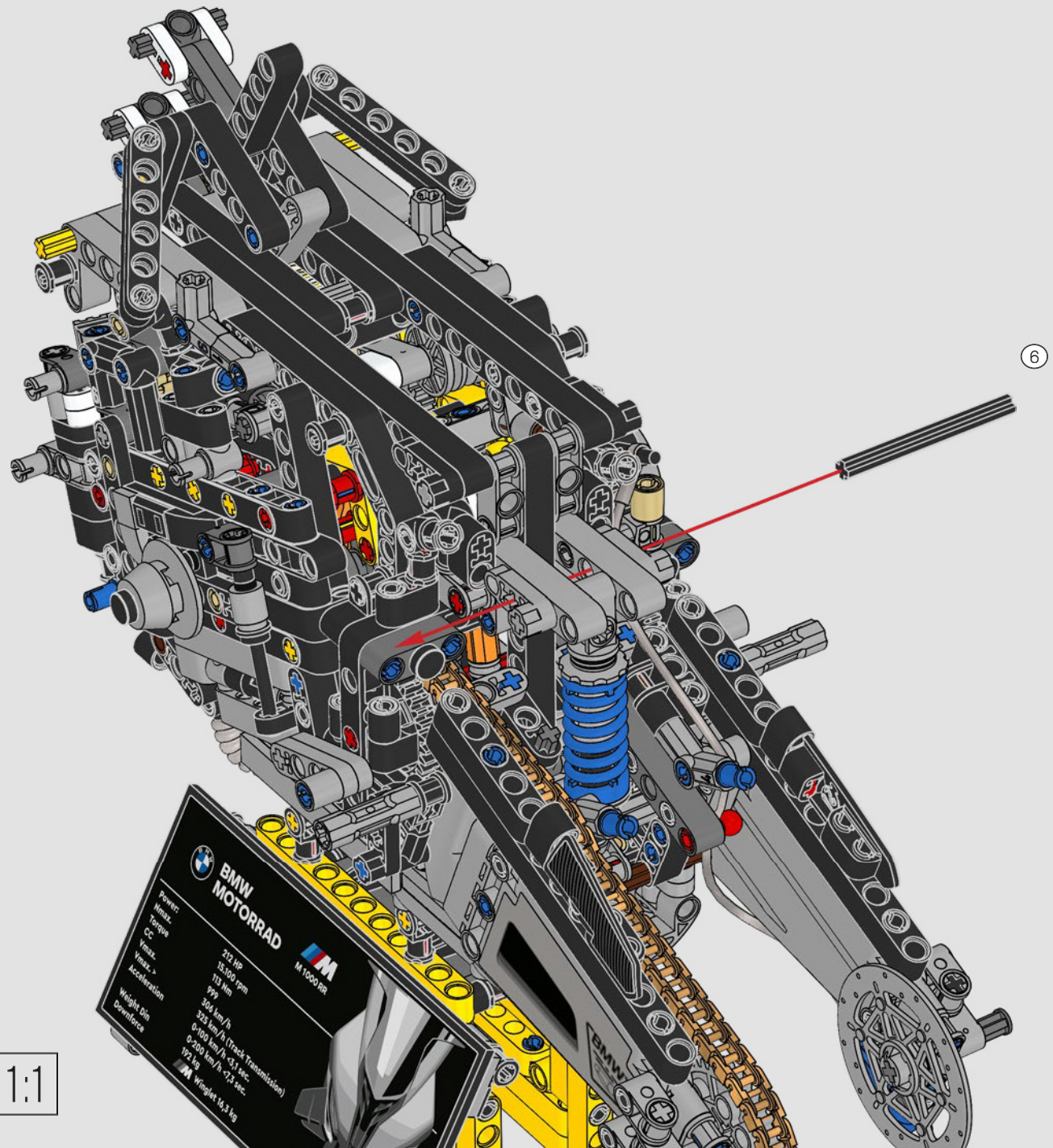

BMW MOTORRAD **M 1000 RR**

Power	217 HP
Max. torque	15,100 Nm
CC	1173
V _{max}	304 km/h
V _{max} >	323 km/h (Track transmission)
Acceleration	0-200 km/h < 3.1 sec.
Weight (Dry)	172 kg
Downforce	0-200 km/h < 1.3 sec.

M Weight 14.3 kg



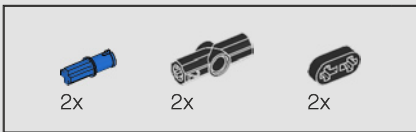

327

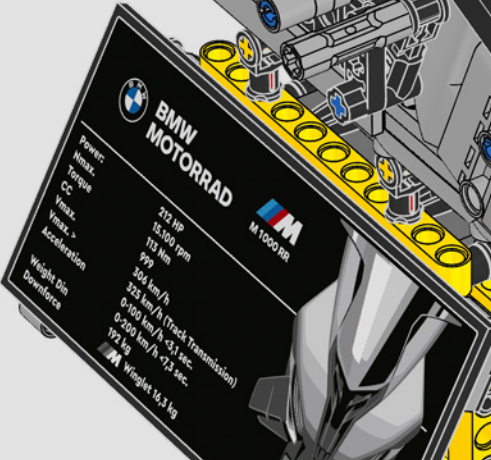
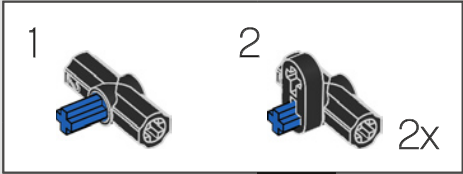
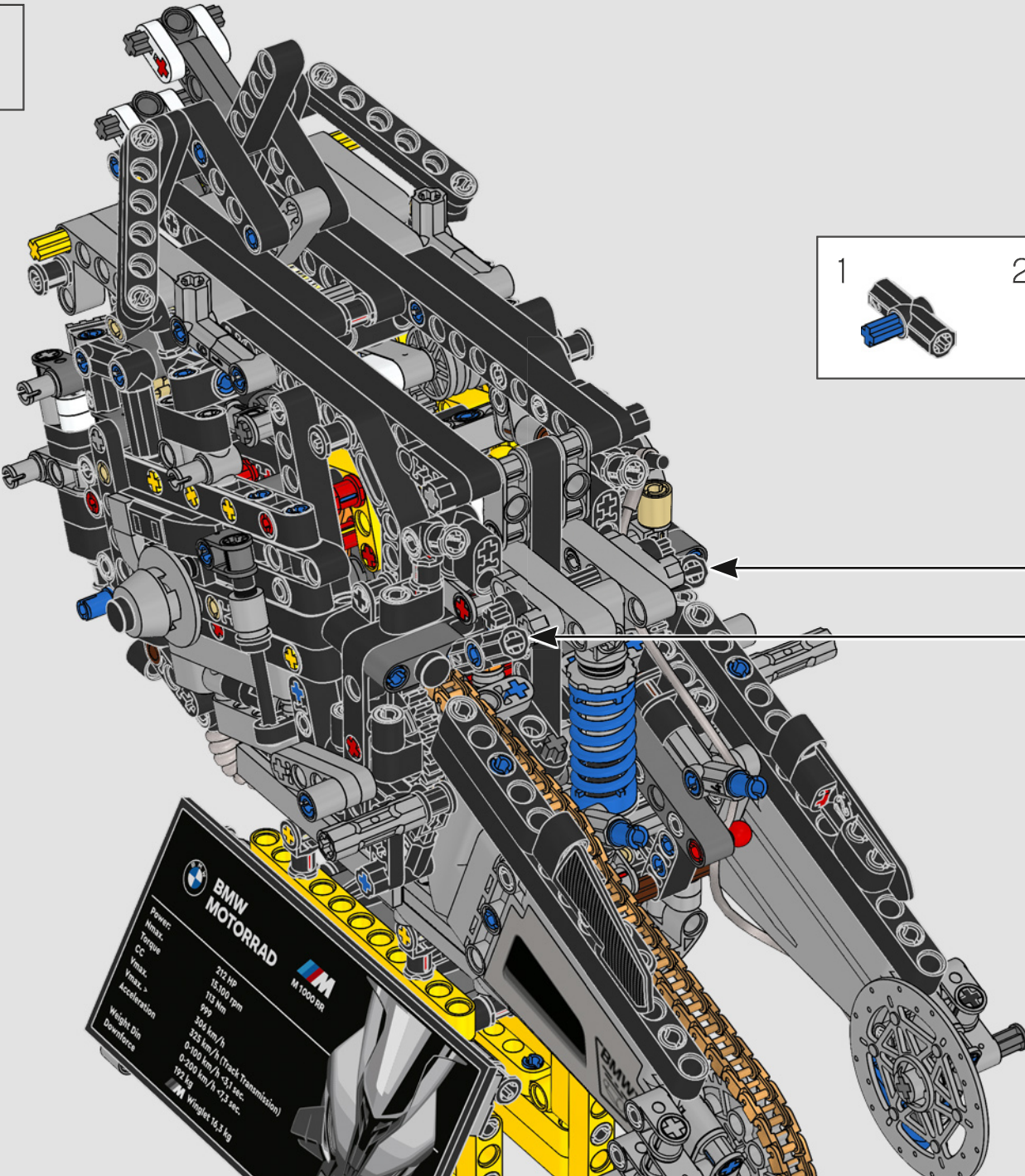

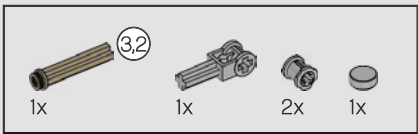

328

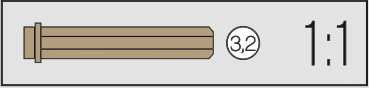
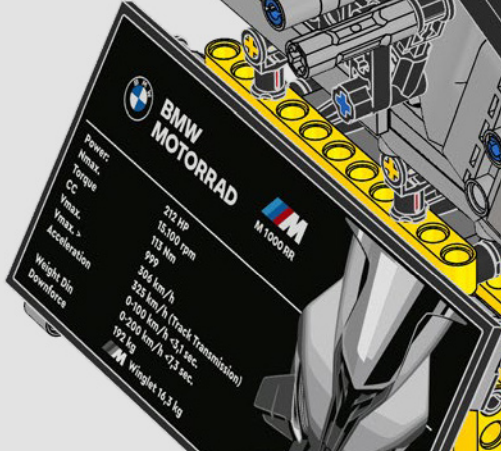
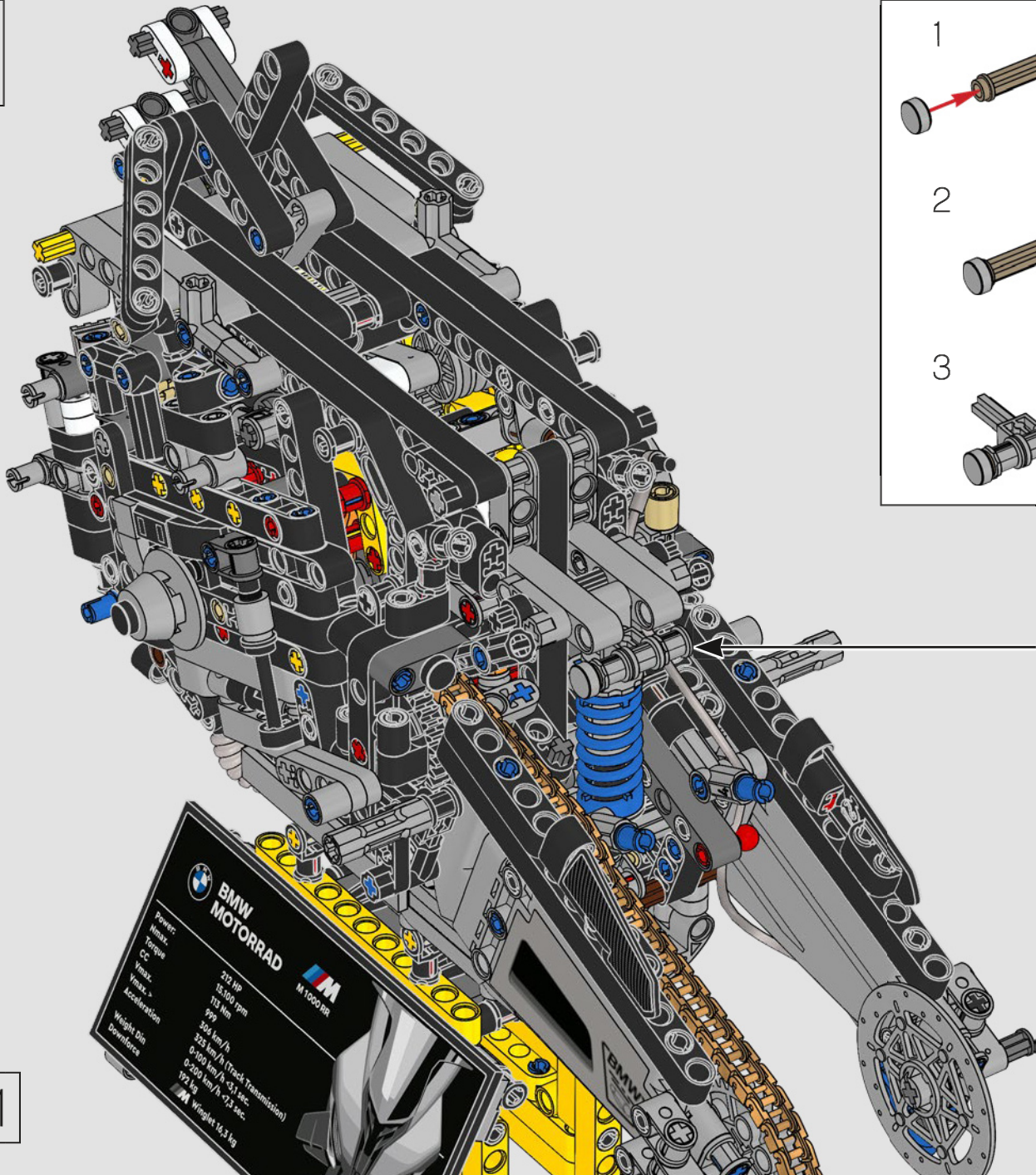
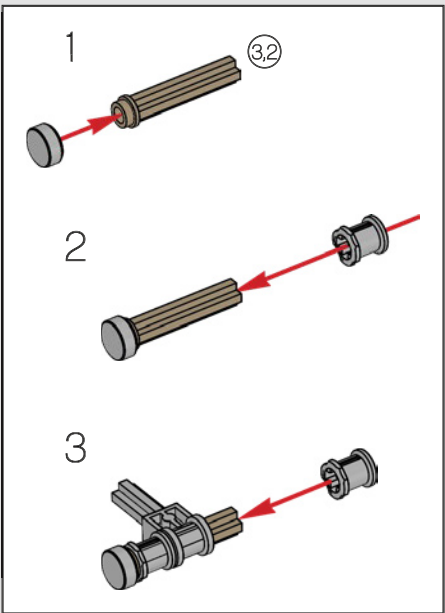

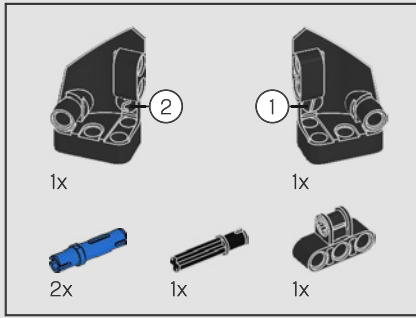

329

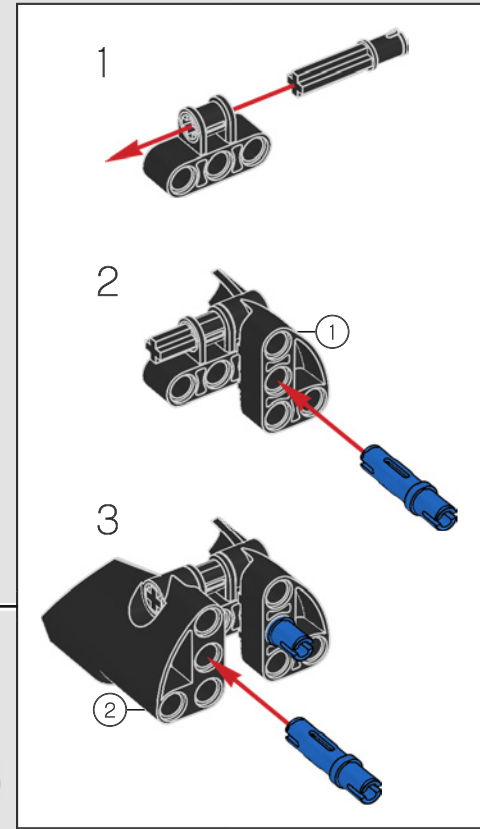
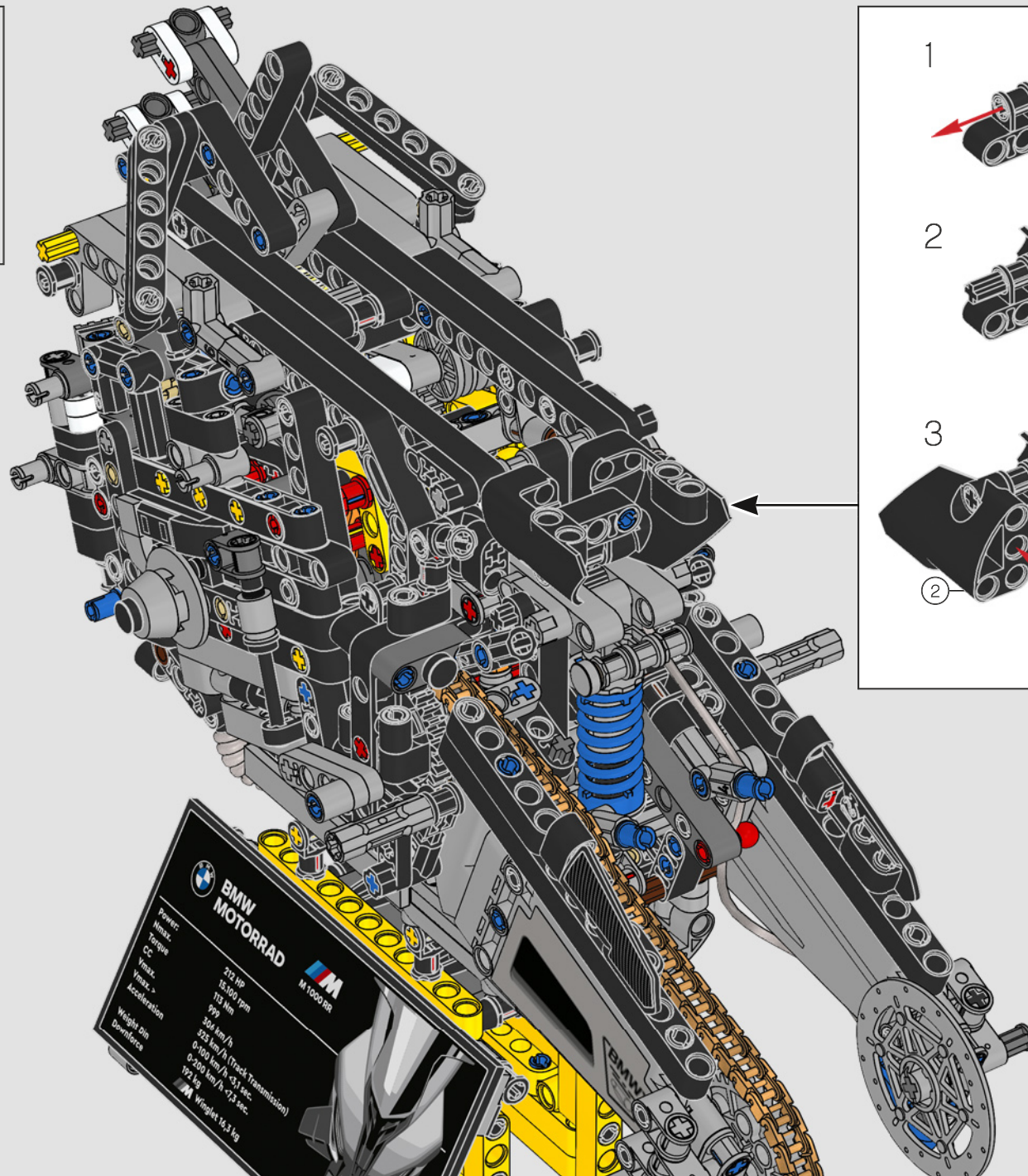

BMW MOTORRAD		M 1000 RR
Power	213 HP	
Max. Torque	15.500 rpm	
CC	1133 cm ³	
0-100 km/h	3.1 sec.	
0-200 km/h	11.3 sec.	
Weight (incl. downforce)	192 kg	
Weight (dry)	163 kg	

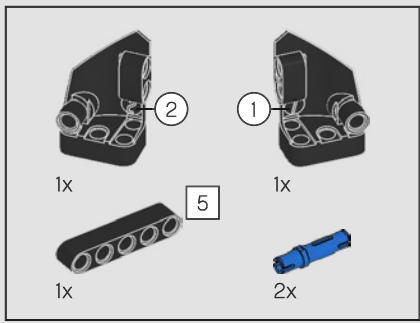

330

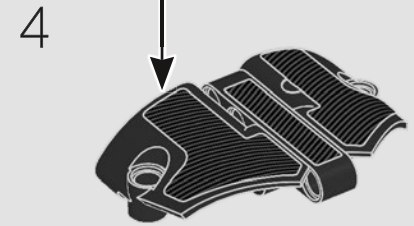
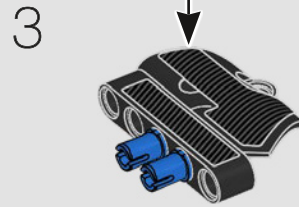
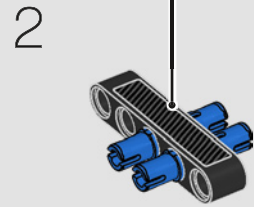
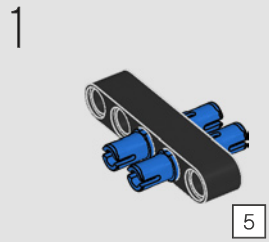

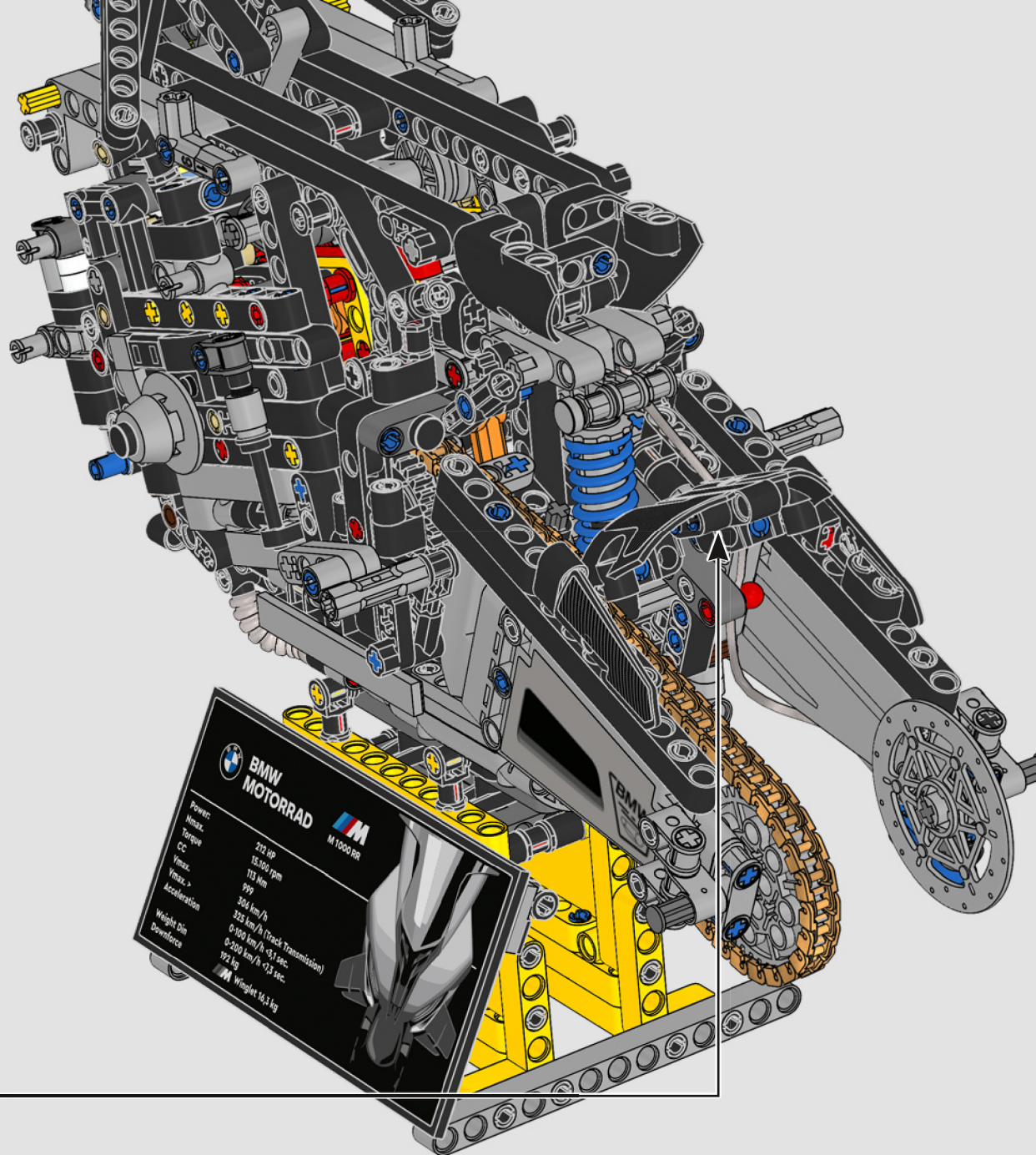

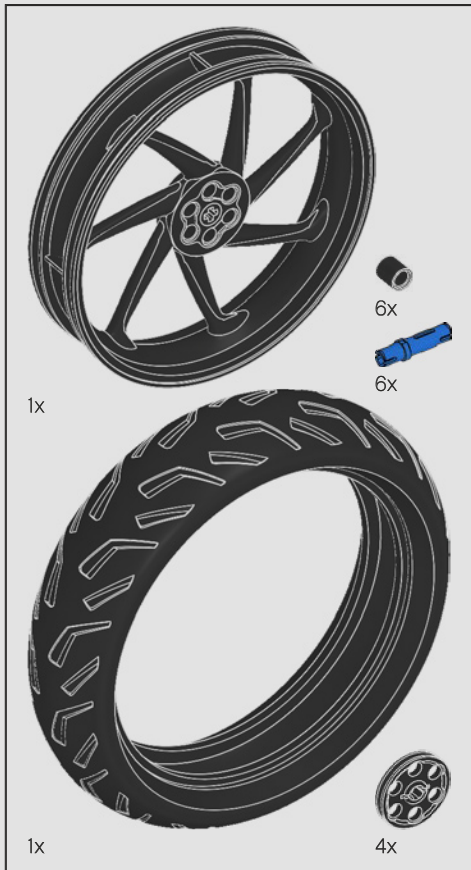

1

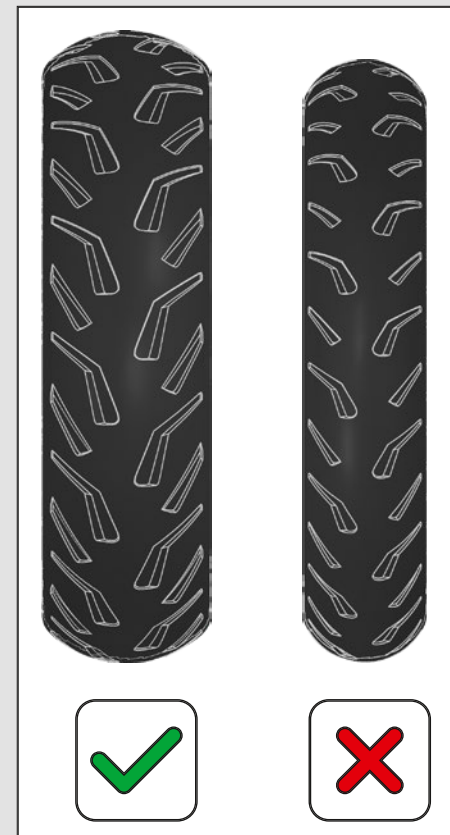
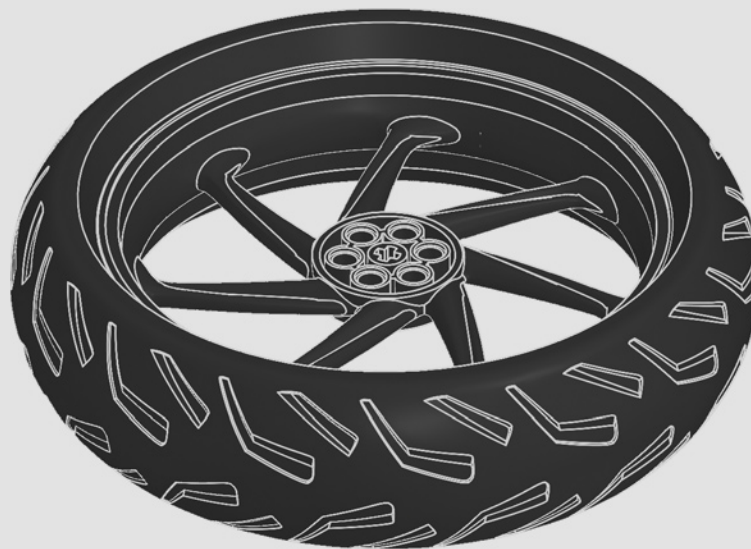

331

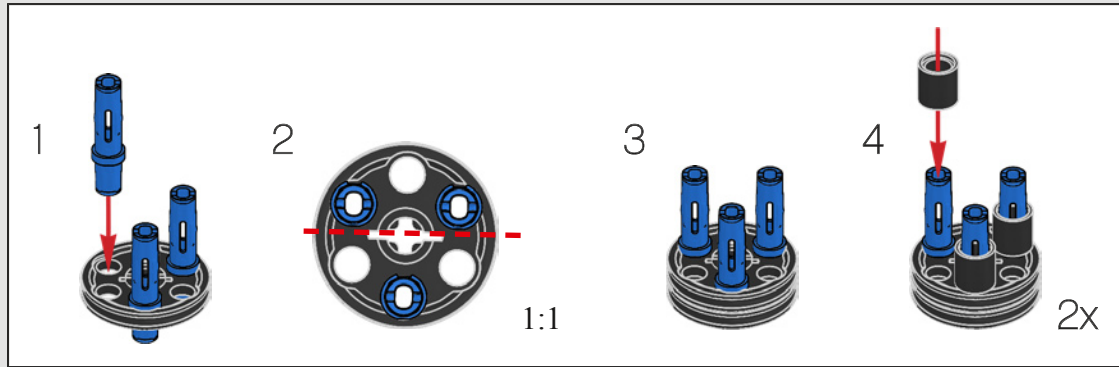

2

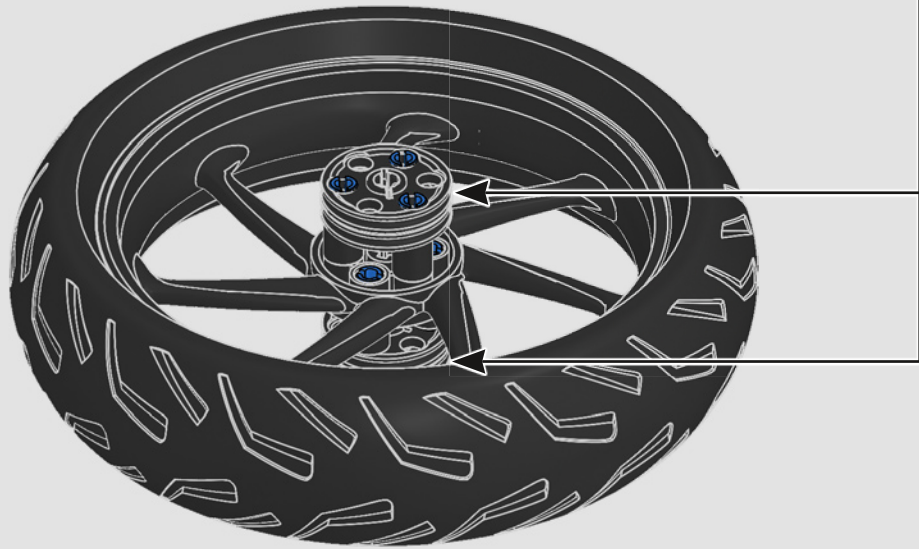

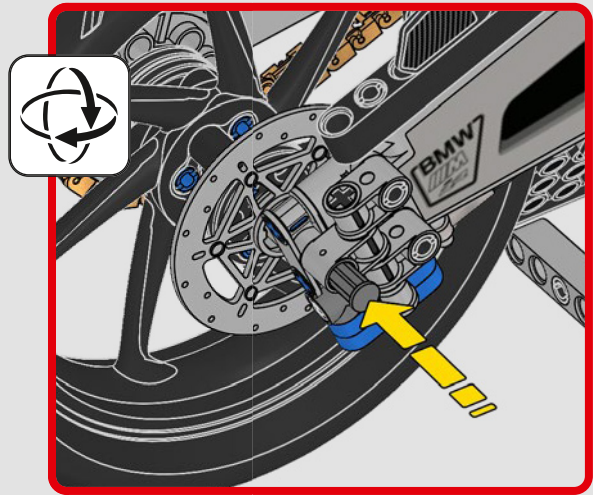
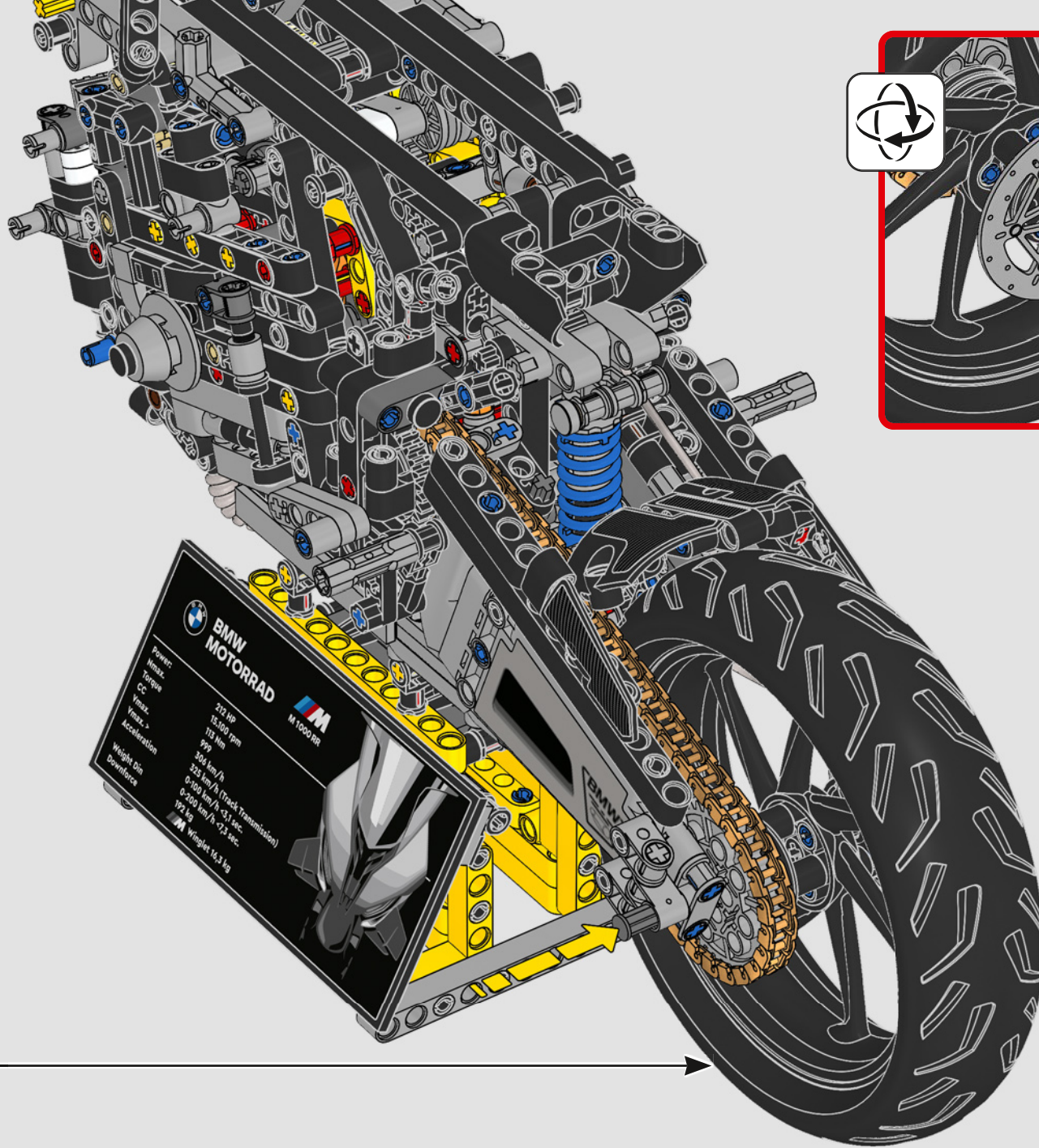

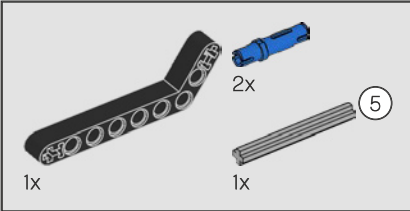
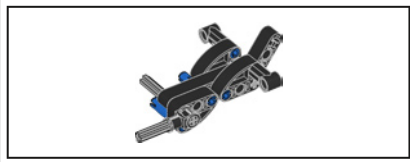

332

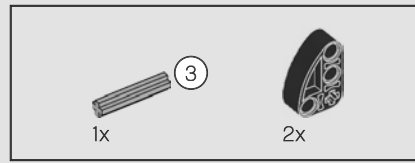
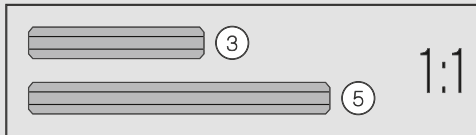
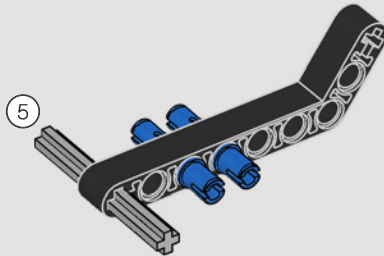

333

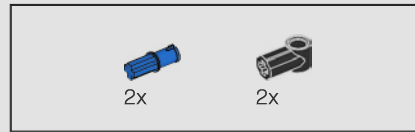
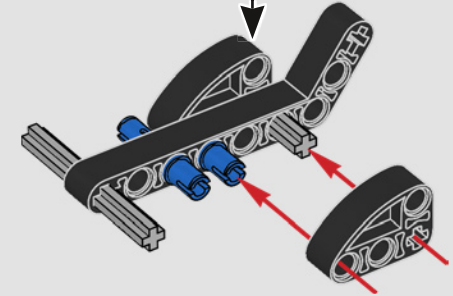
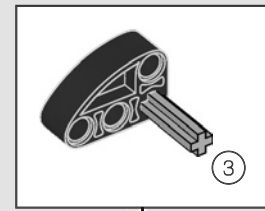

334

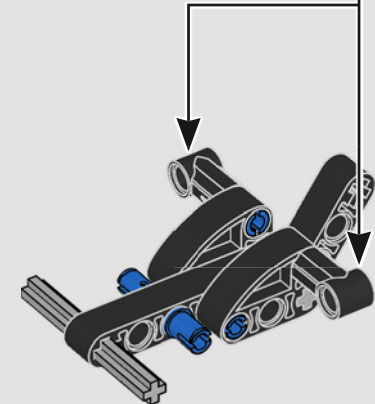

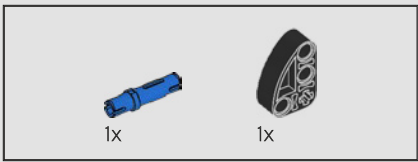

335

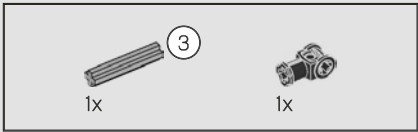
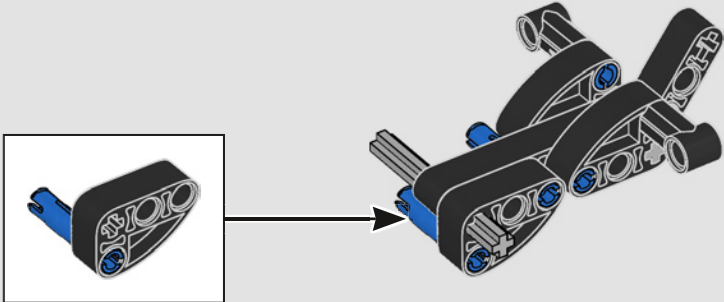

336

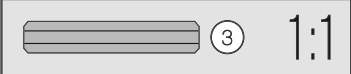
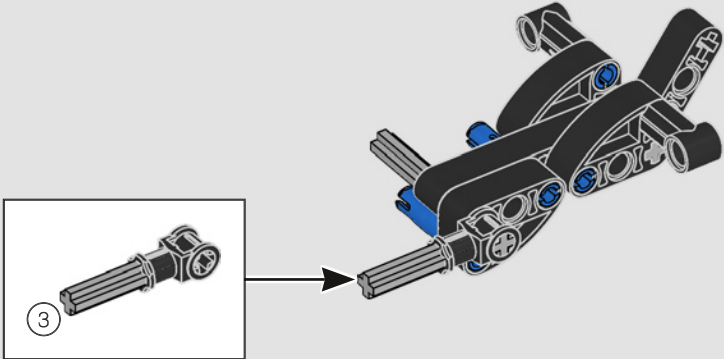

337

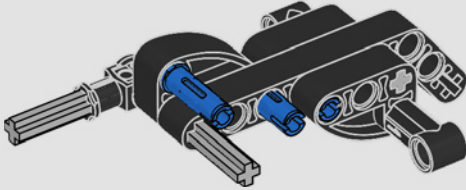

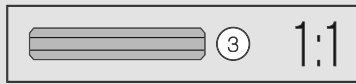
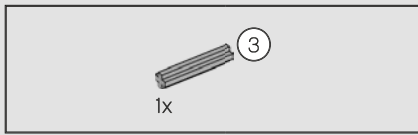

338

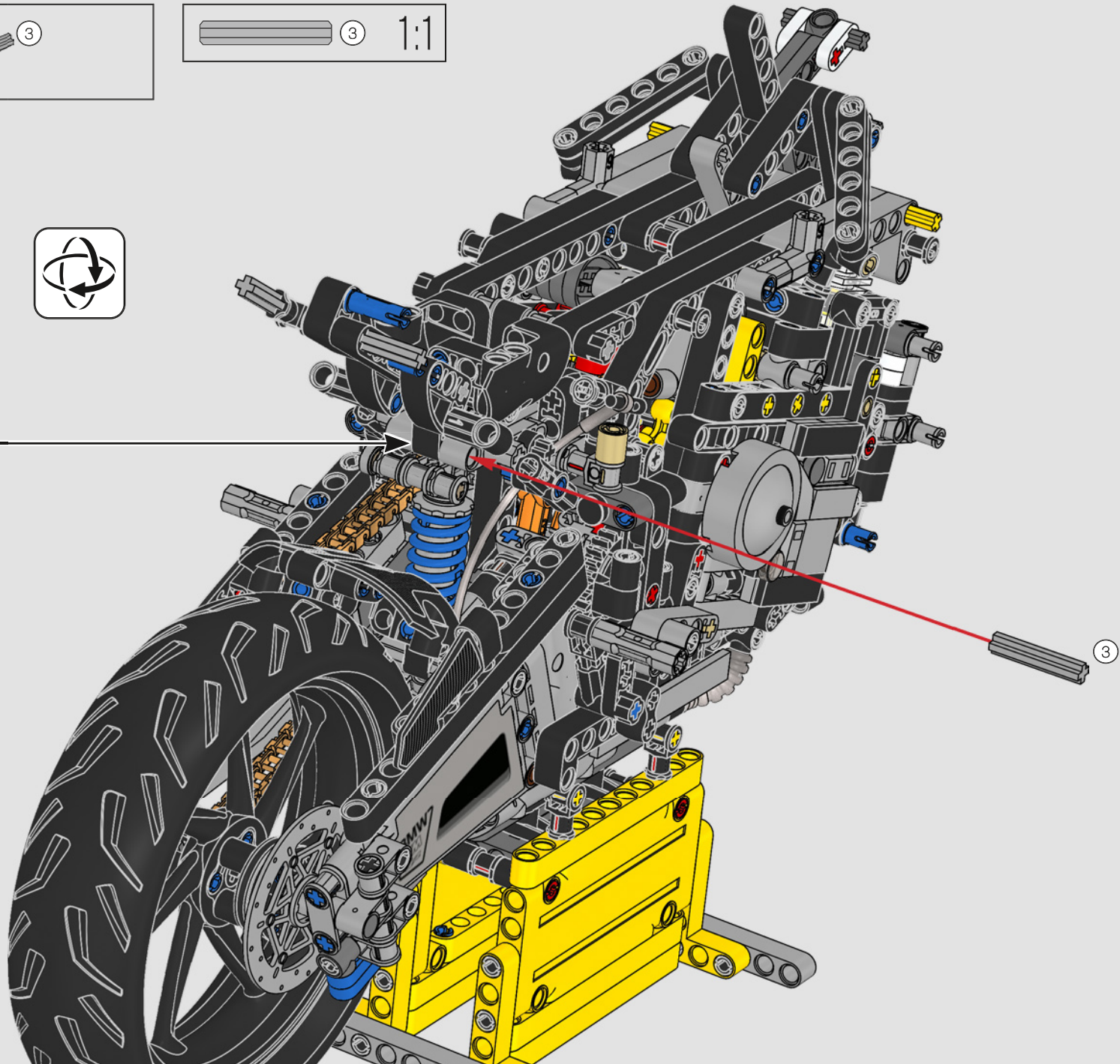

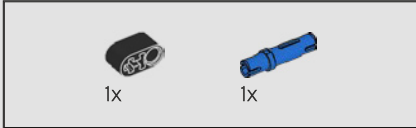
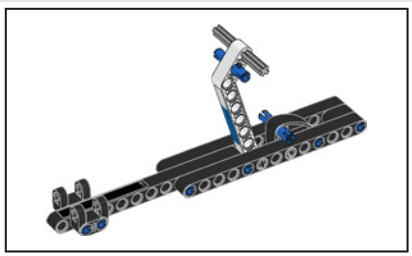

339

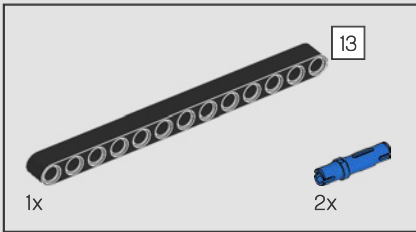

340

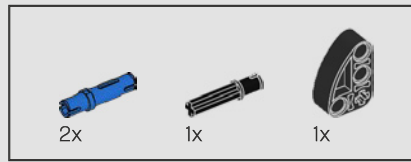
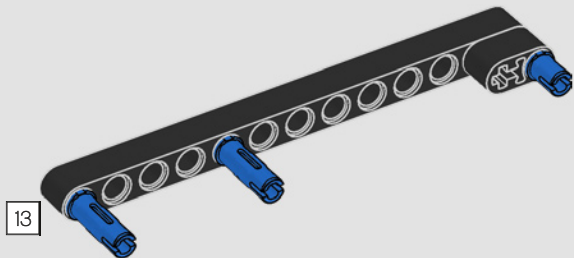

341

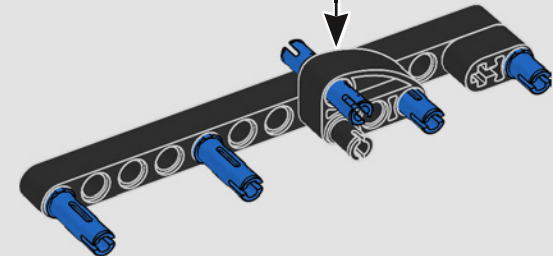
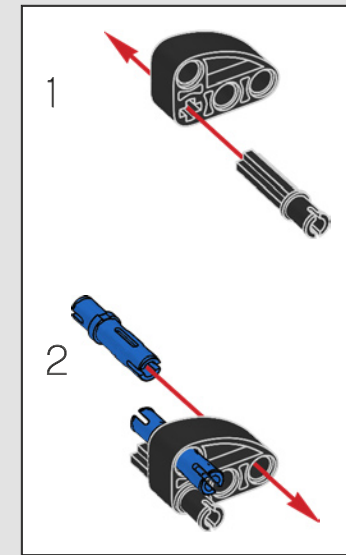

1:1

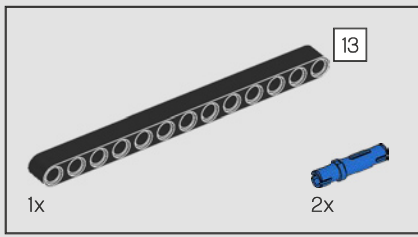

342

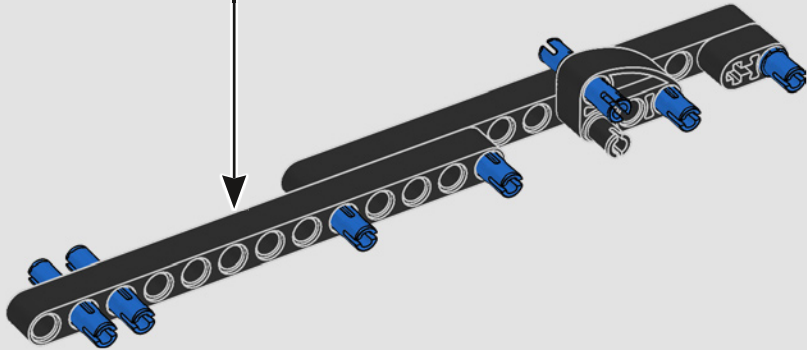
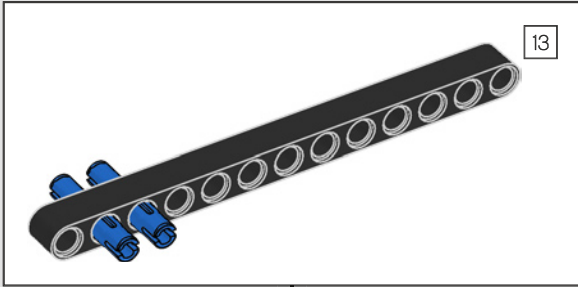

343

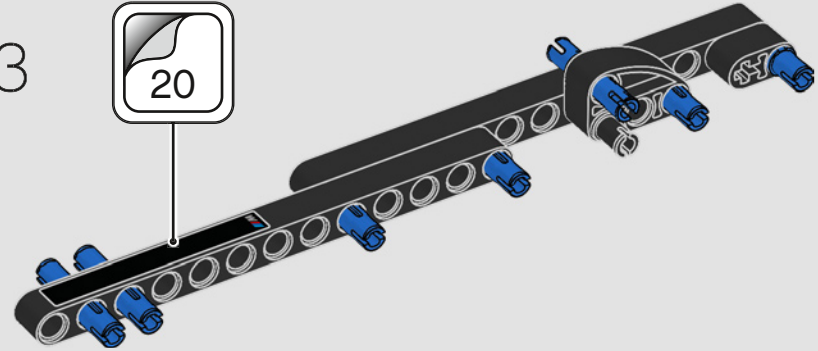

344

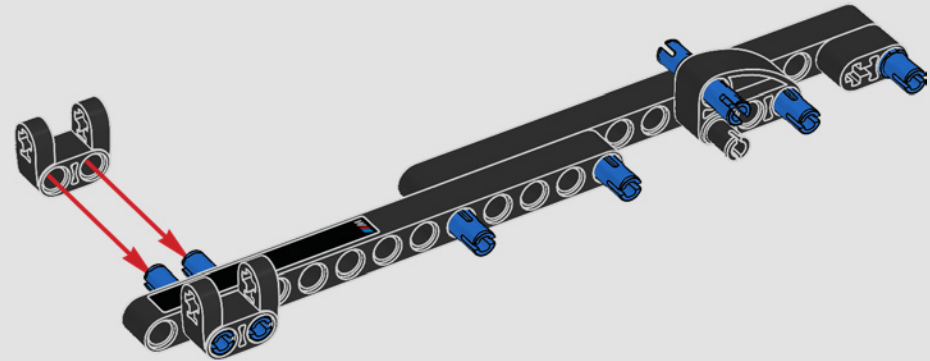

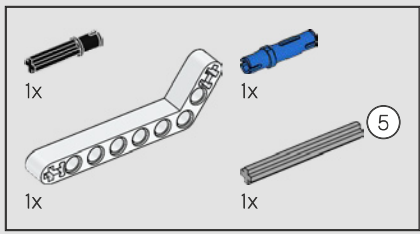

345

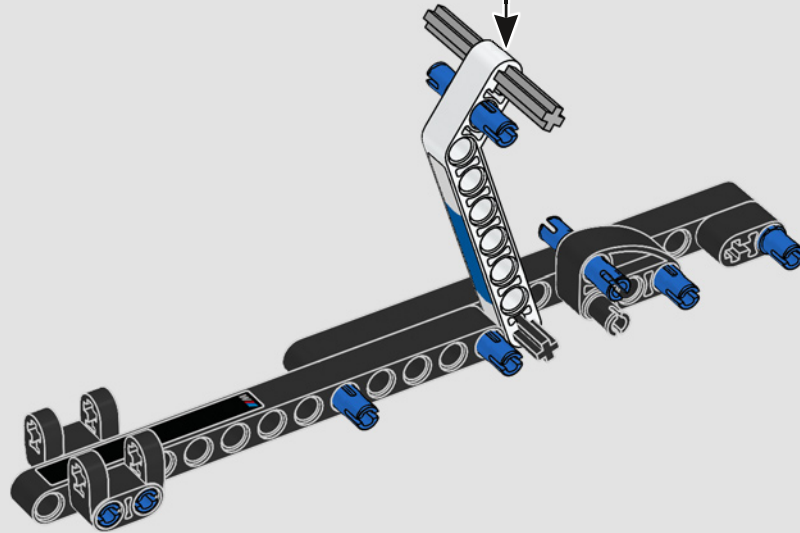
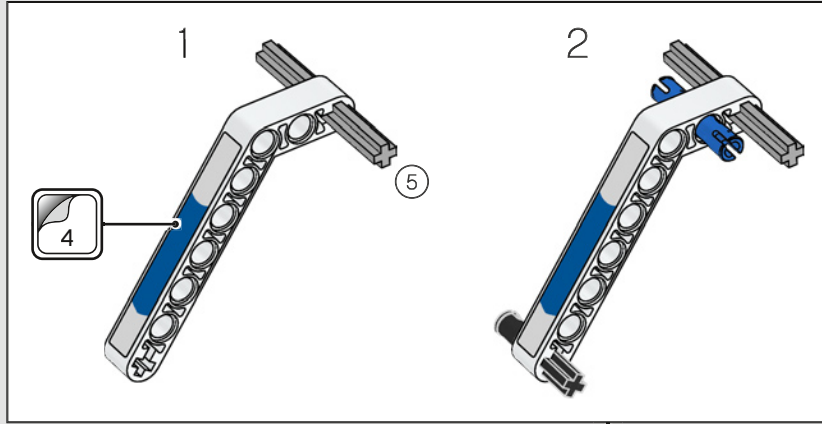
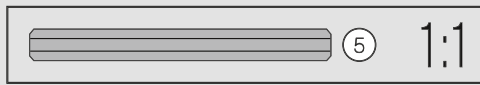

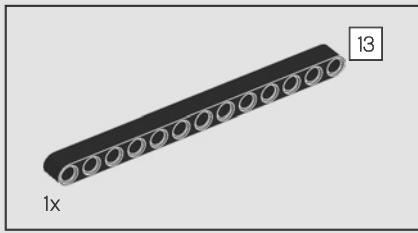

346

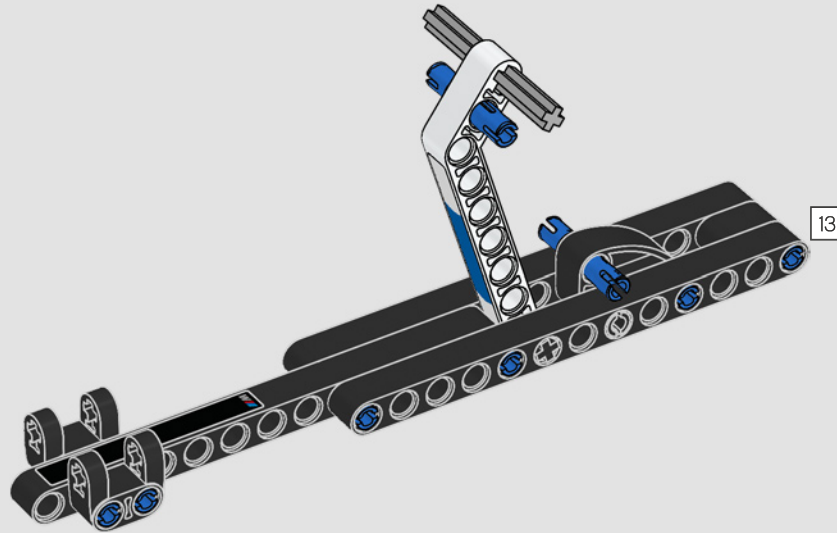

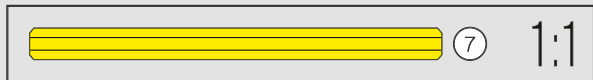
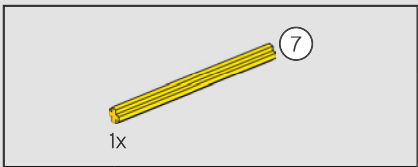

347

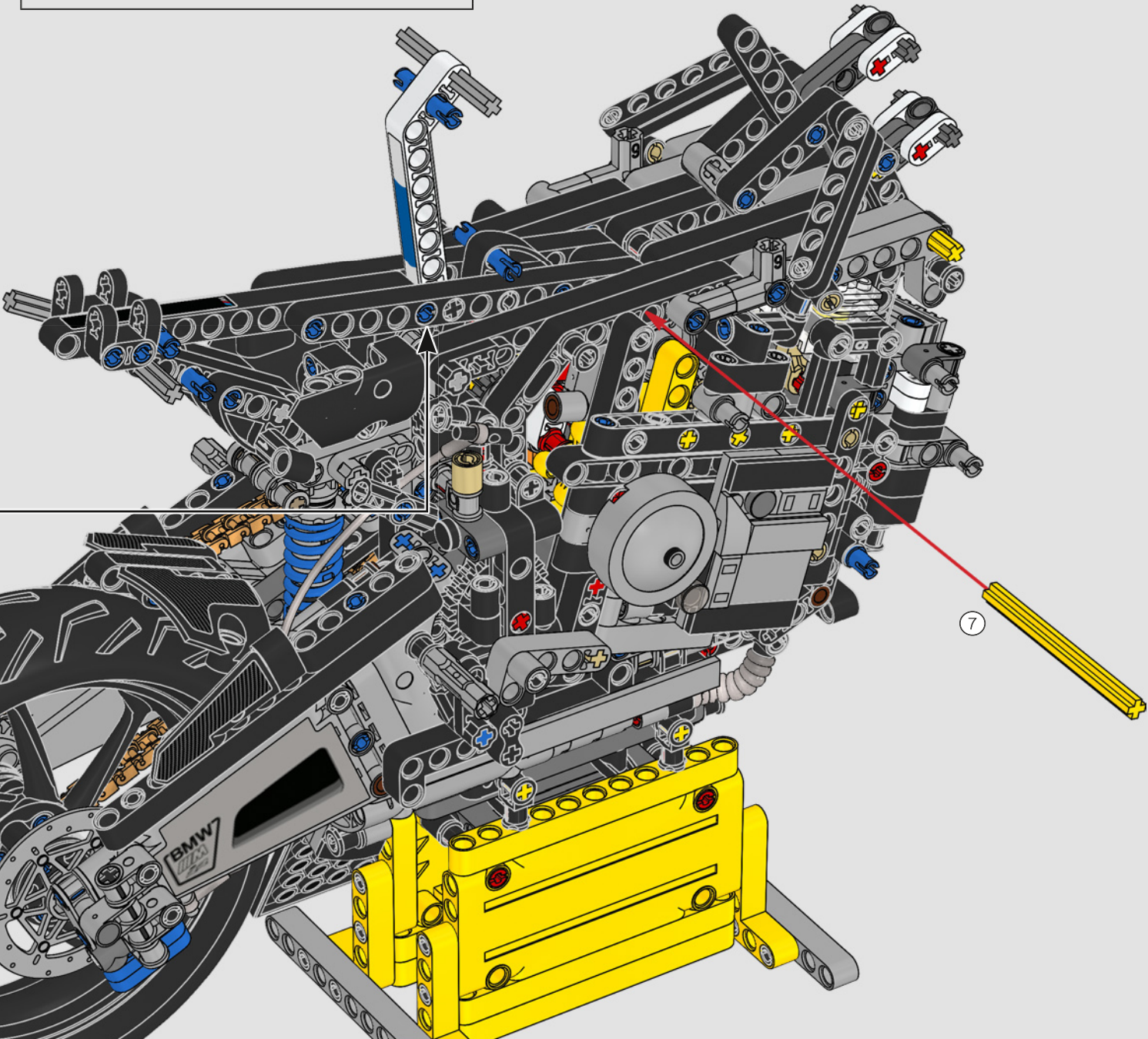
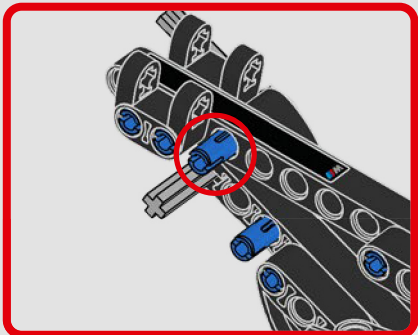

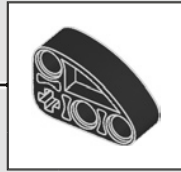
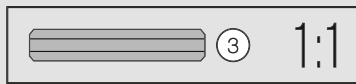

348

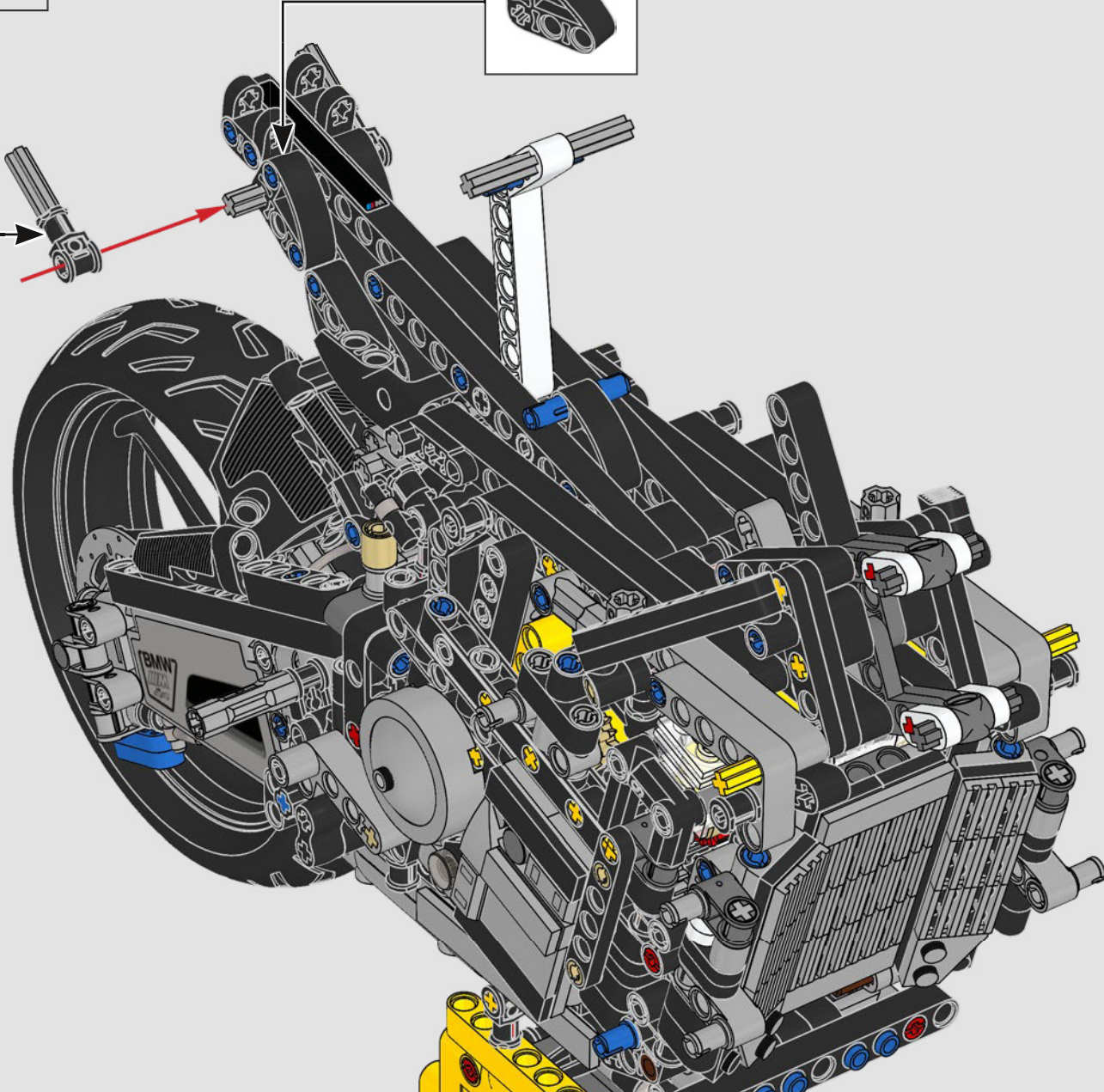
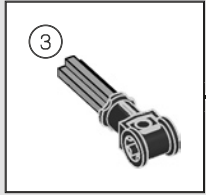

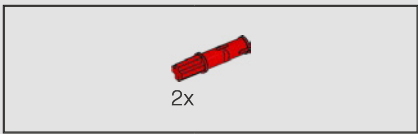

349

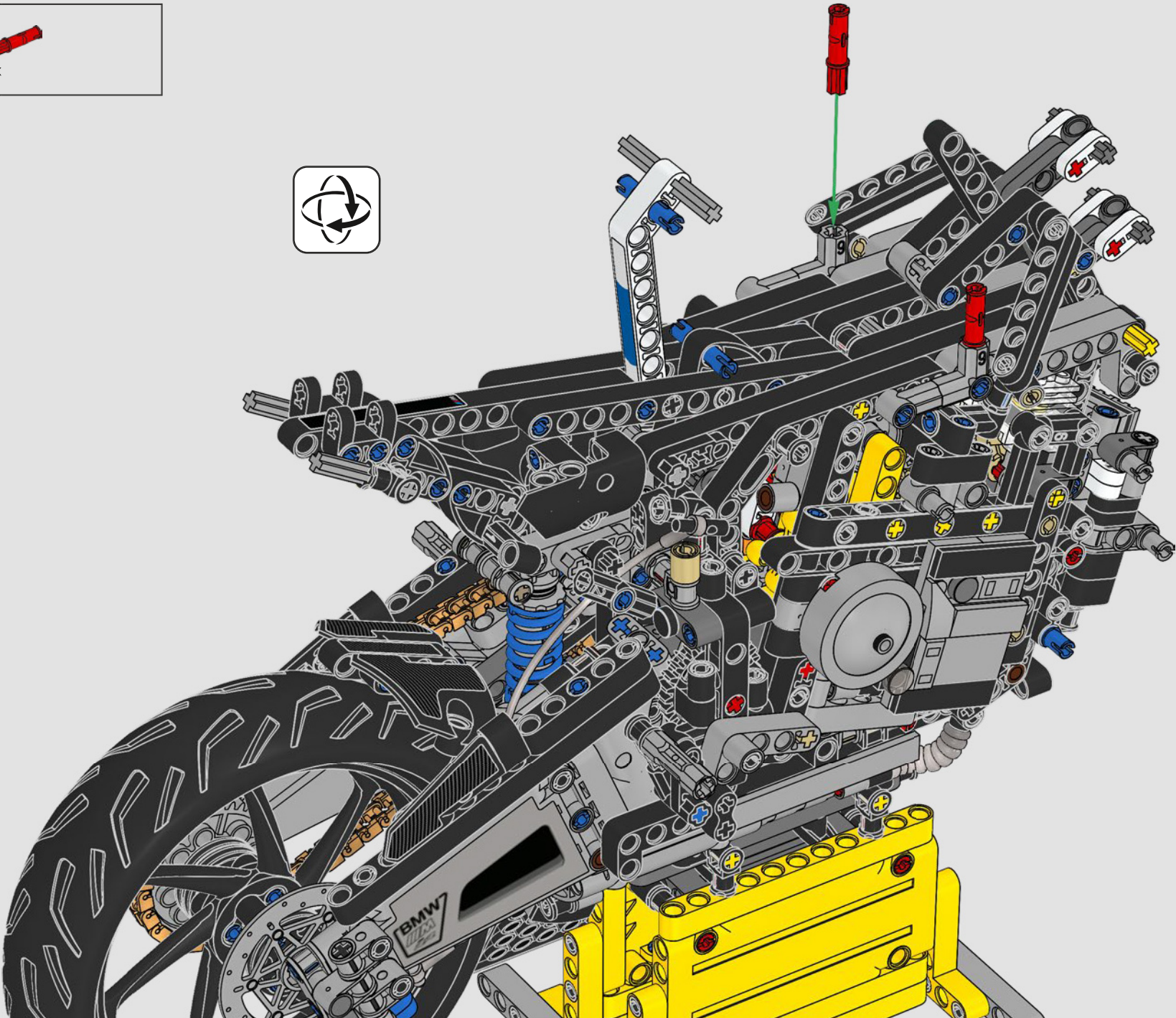

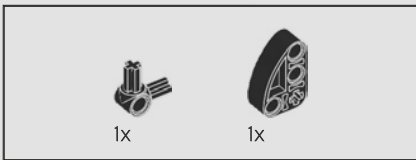

350

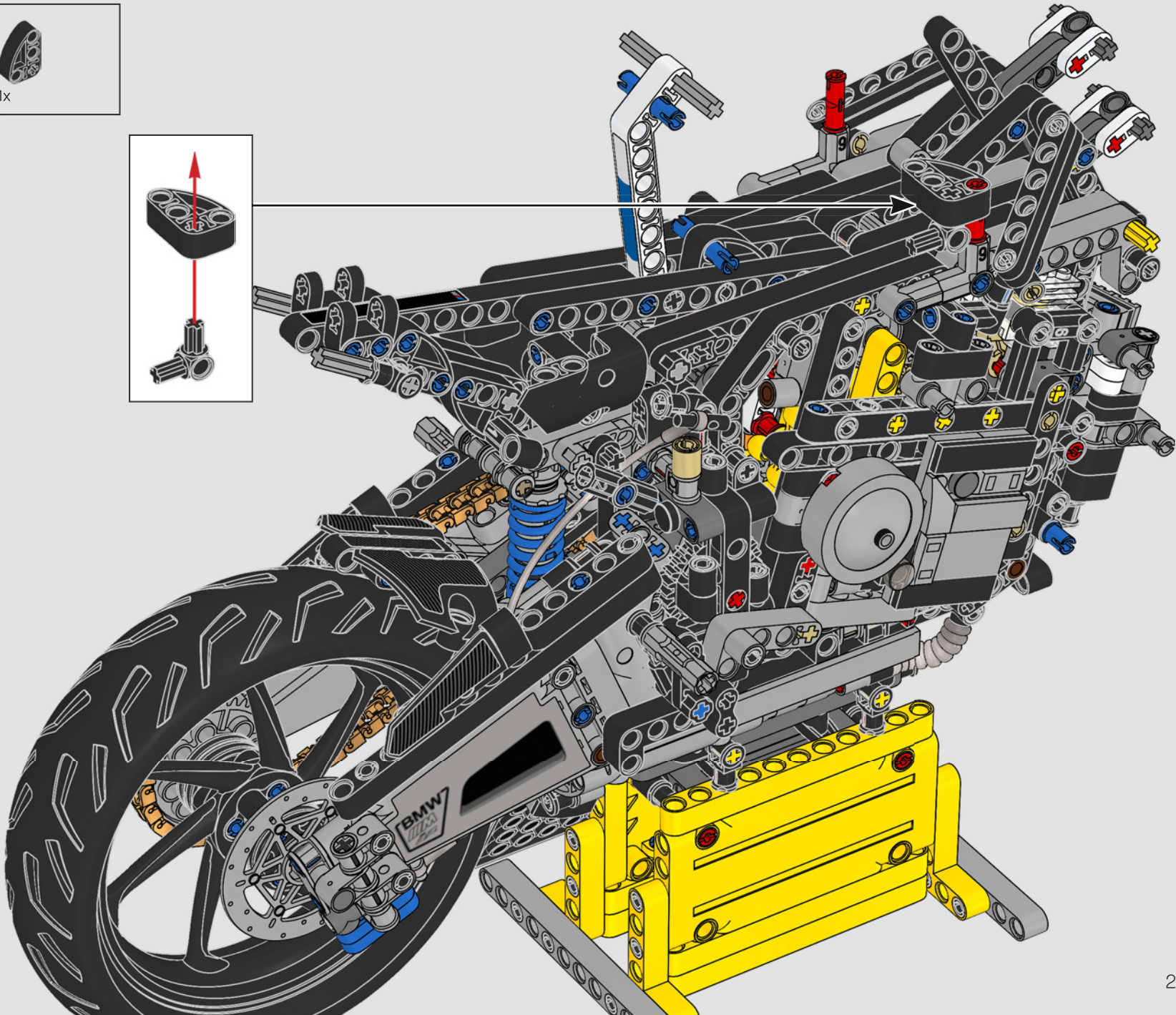
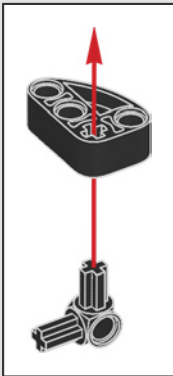

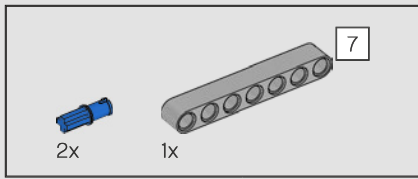

351

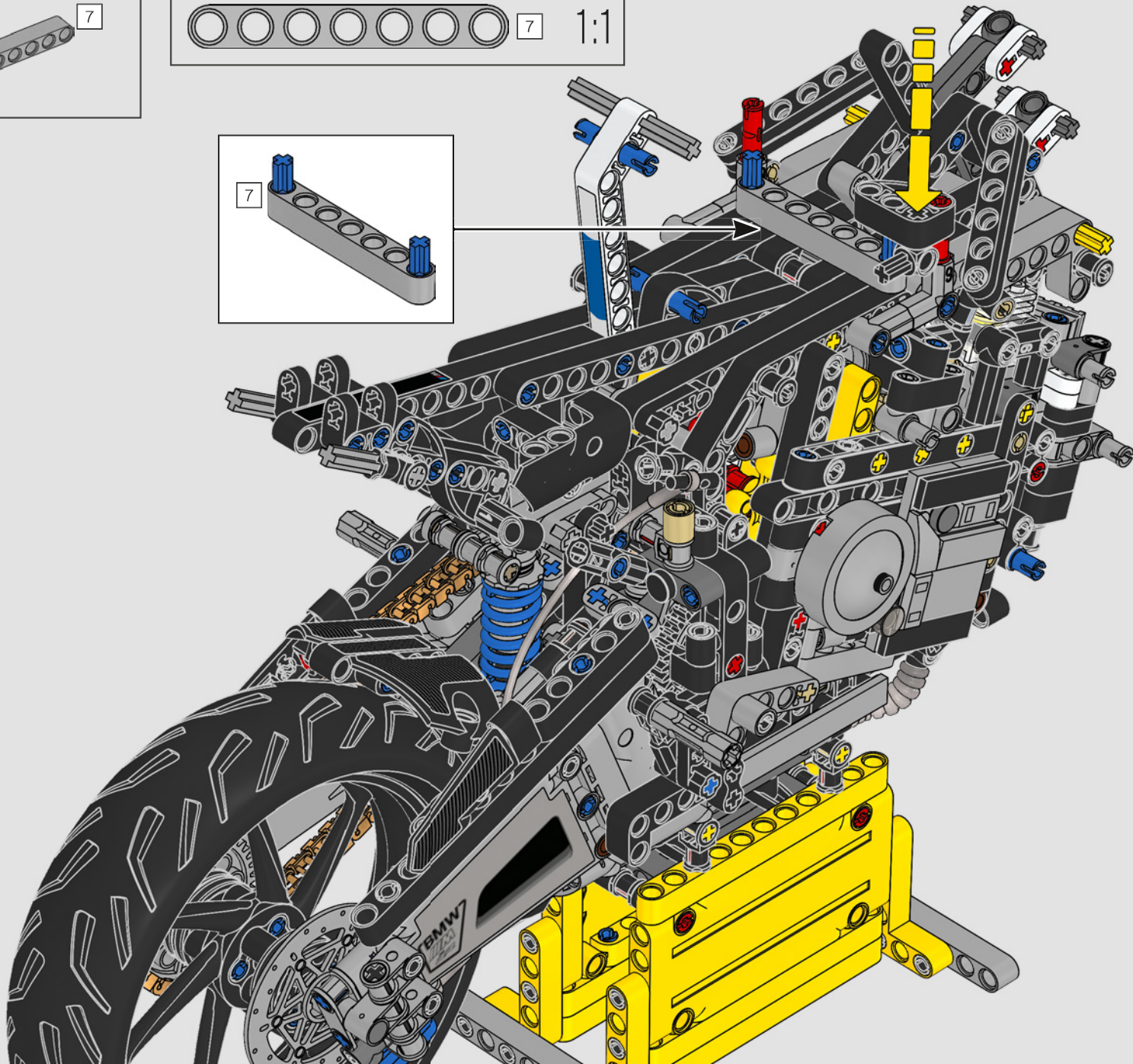
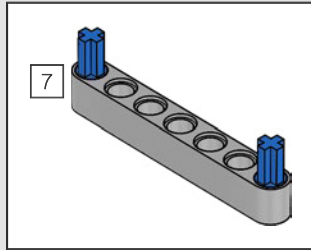

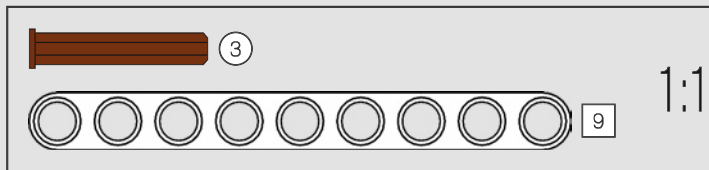
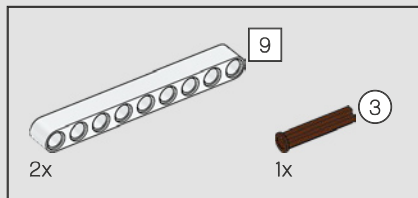

352

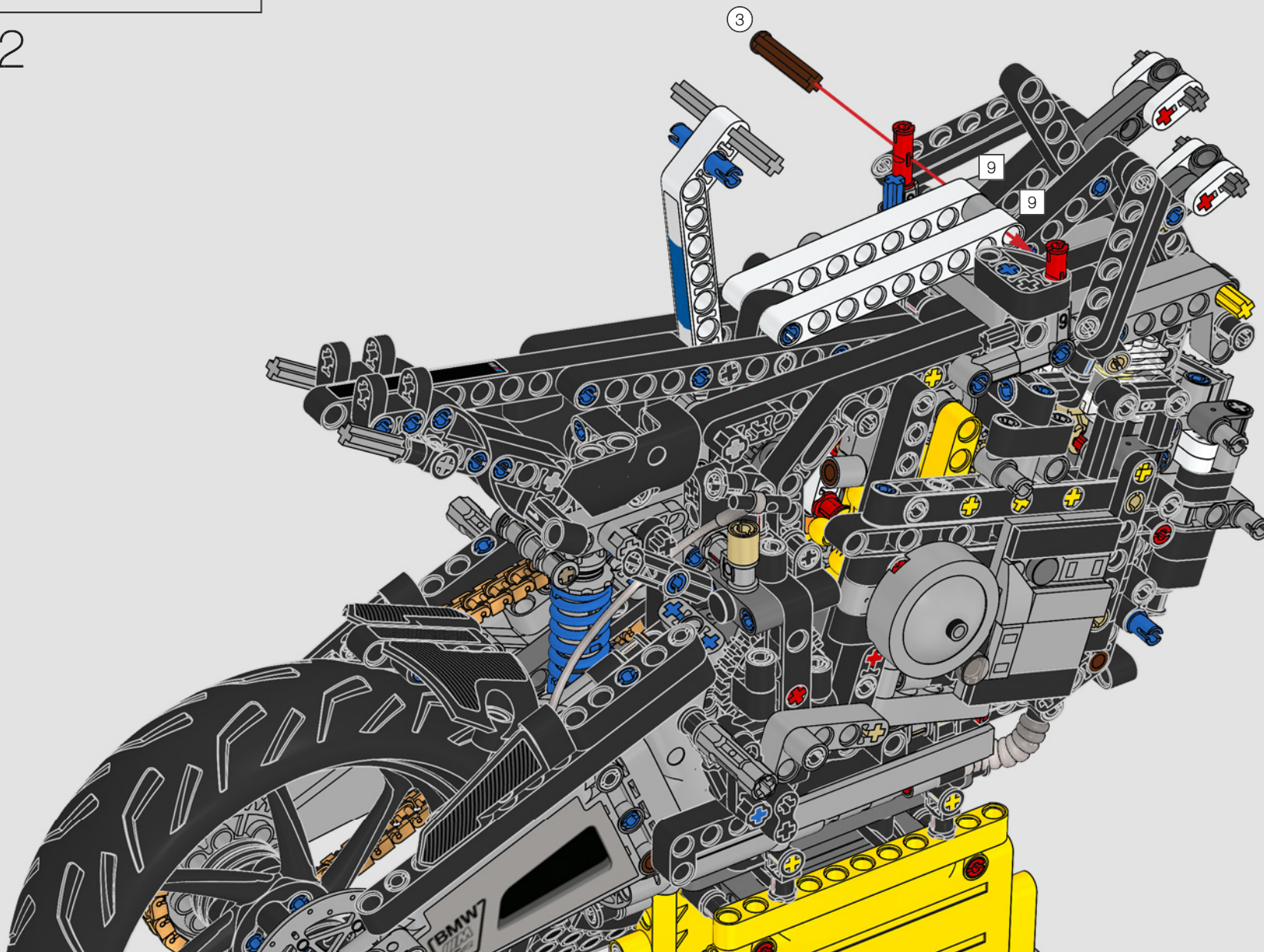

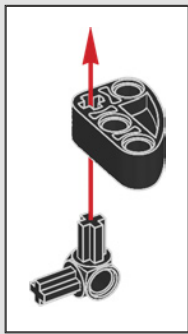
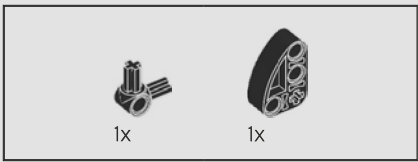

353

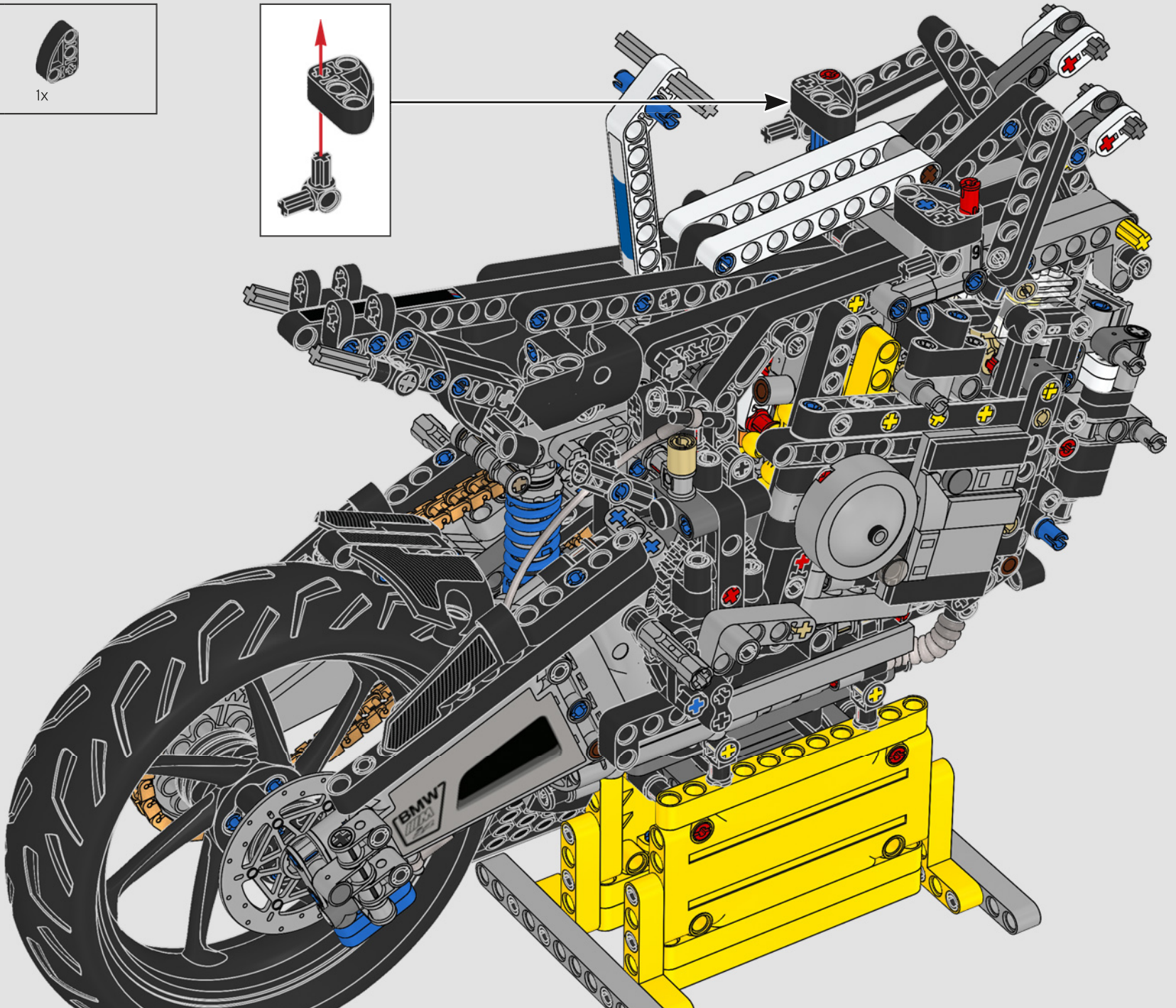



354

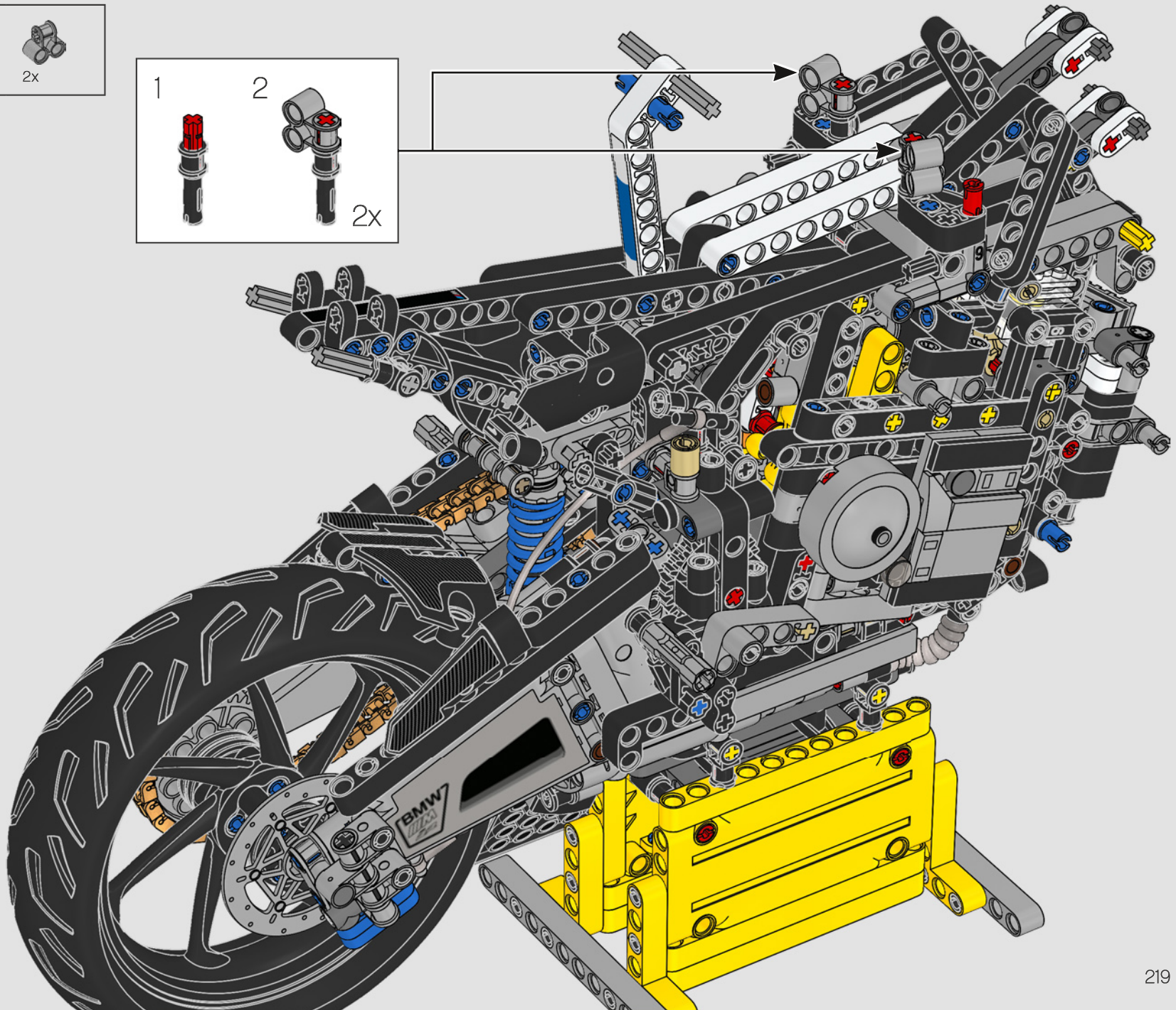
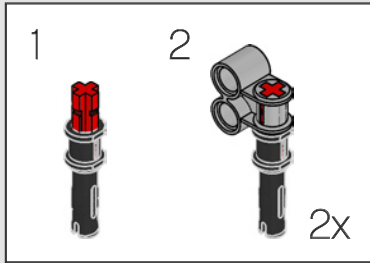

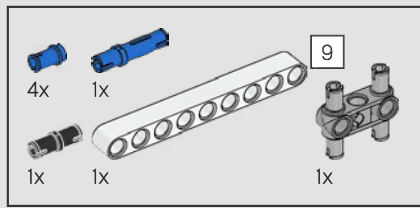

355

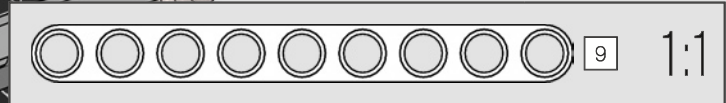
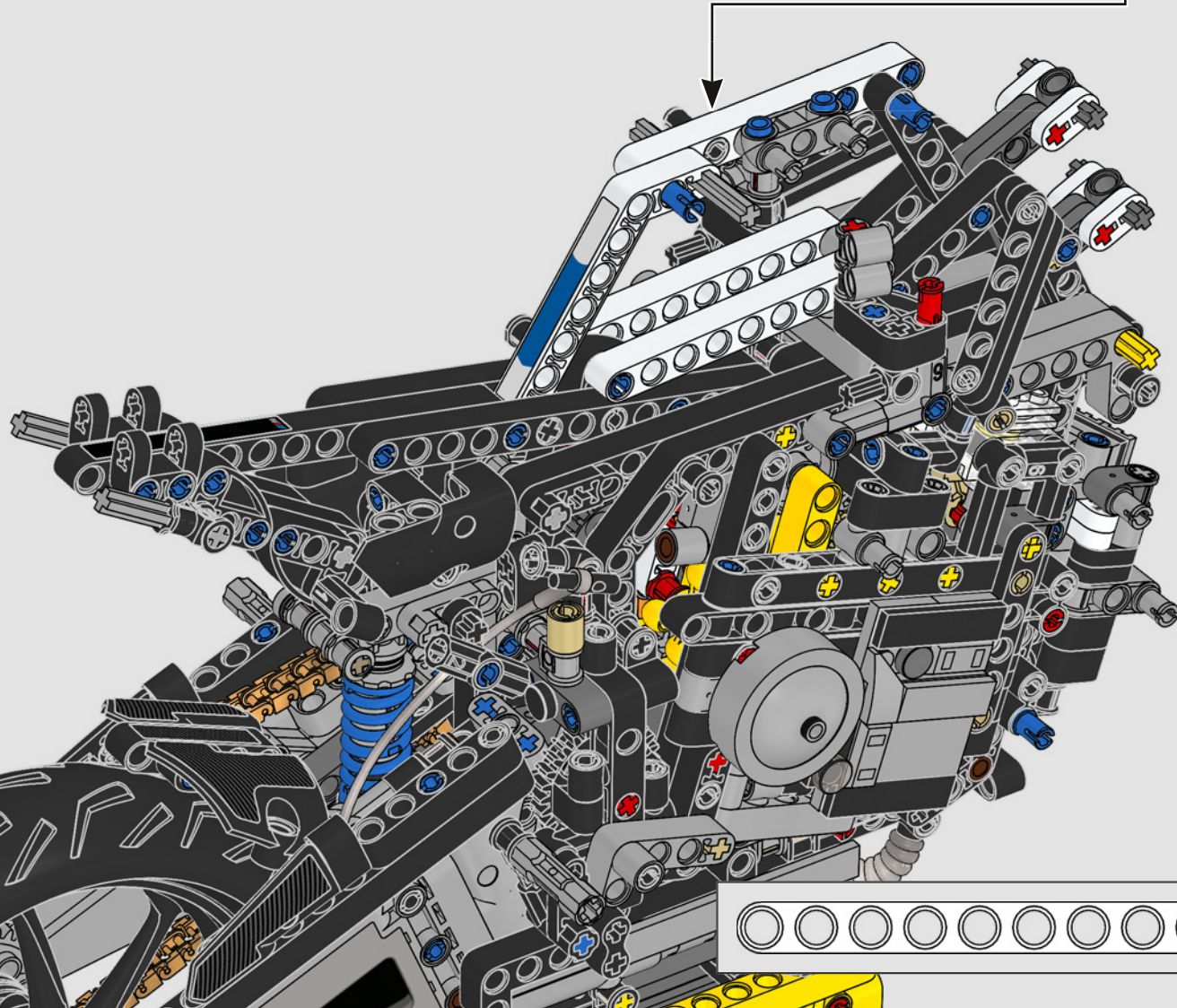
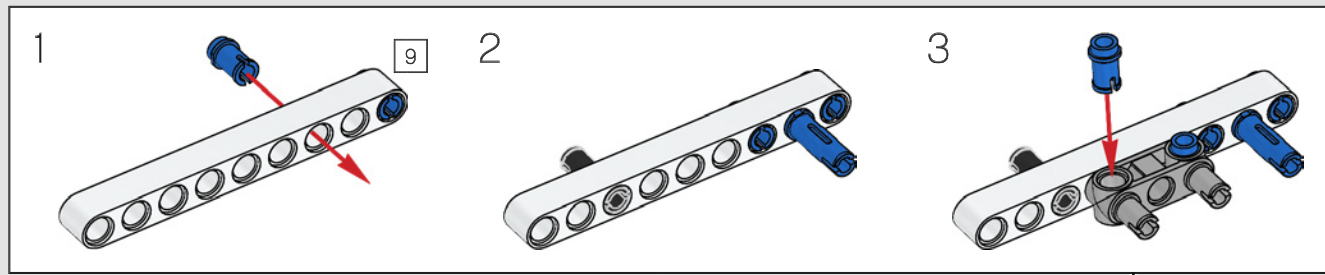

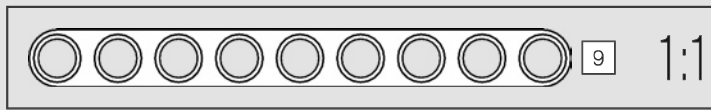
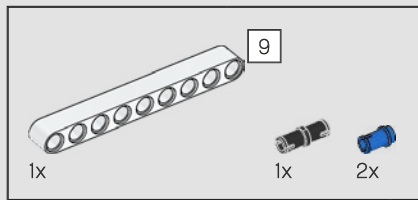

356

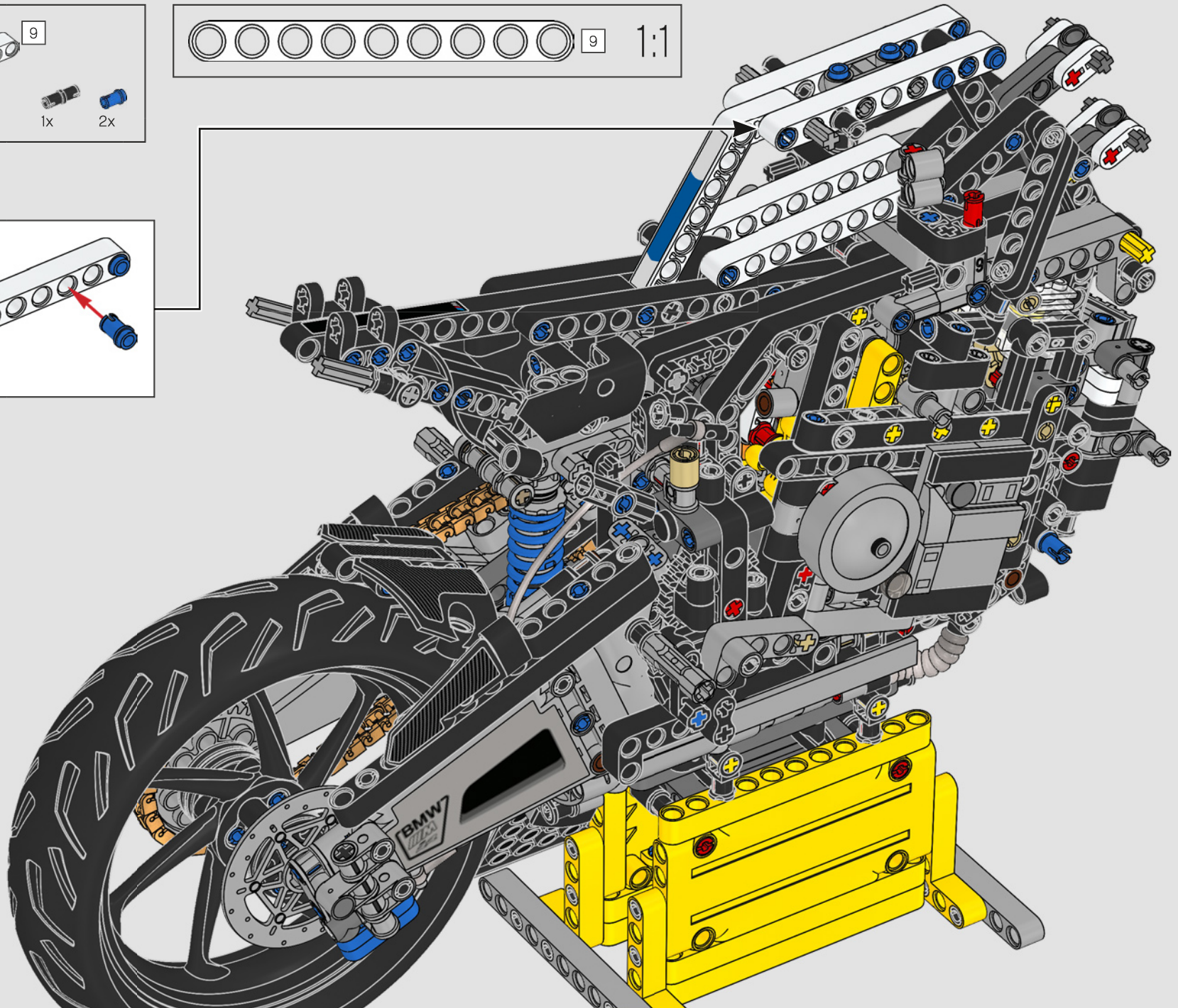
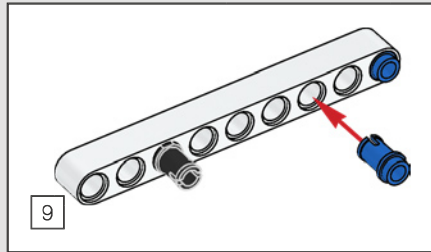

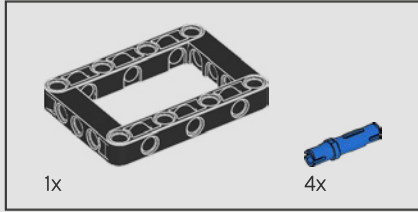
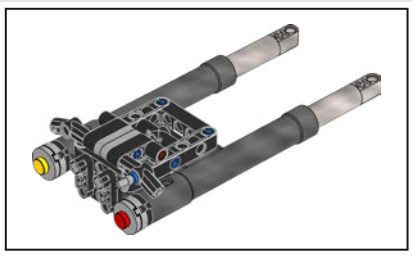

357

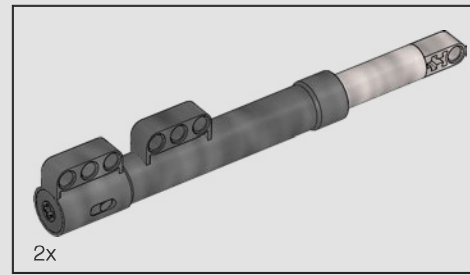
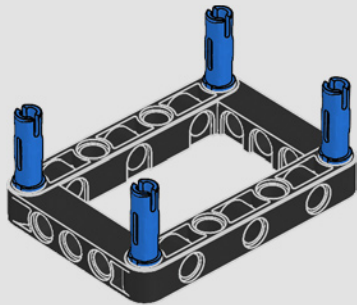

358

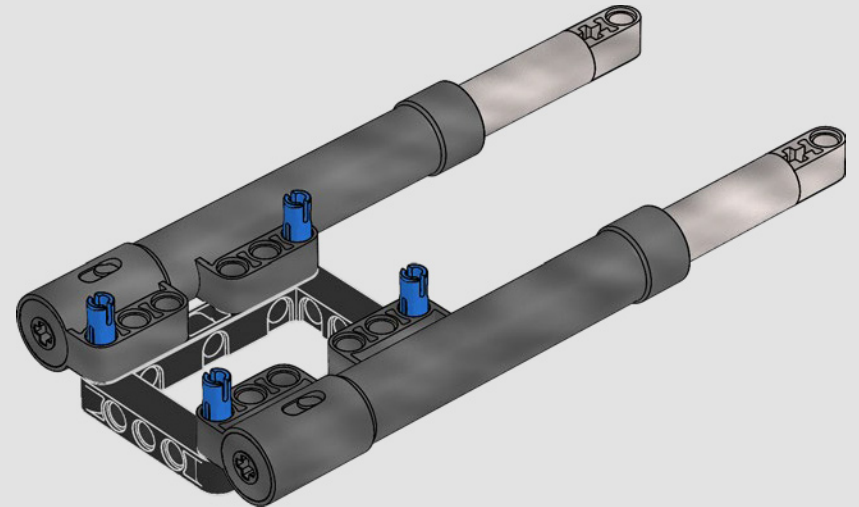

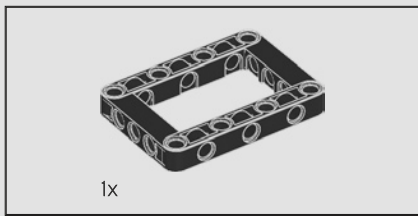

1x

359

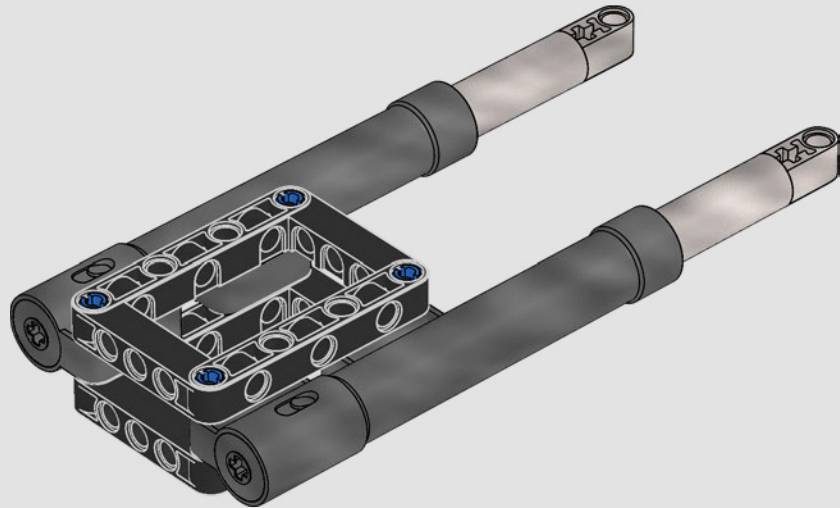

360

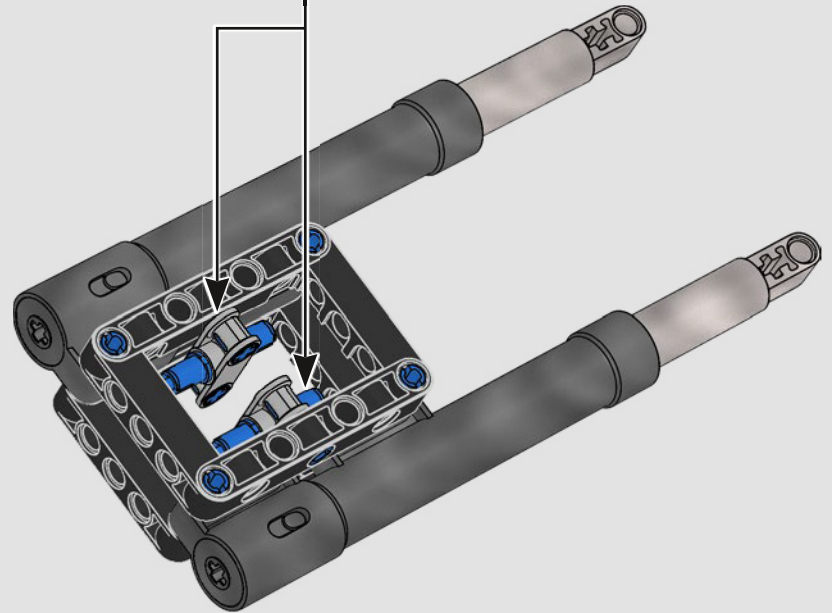
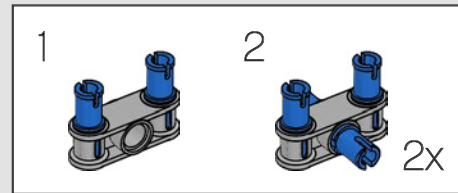
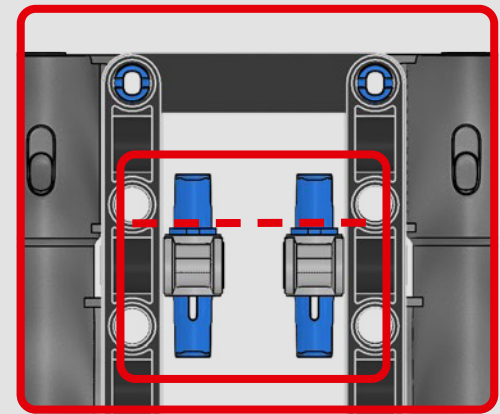

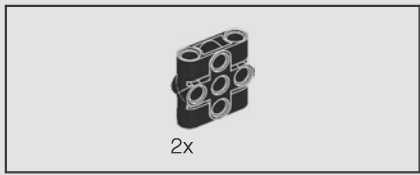

361

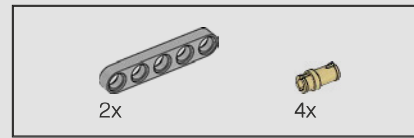
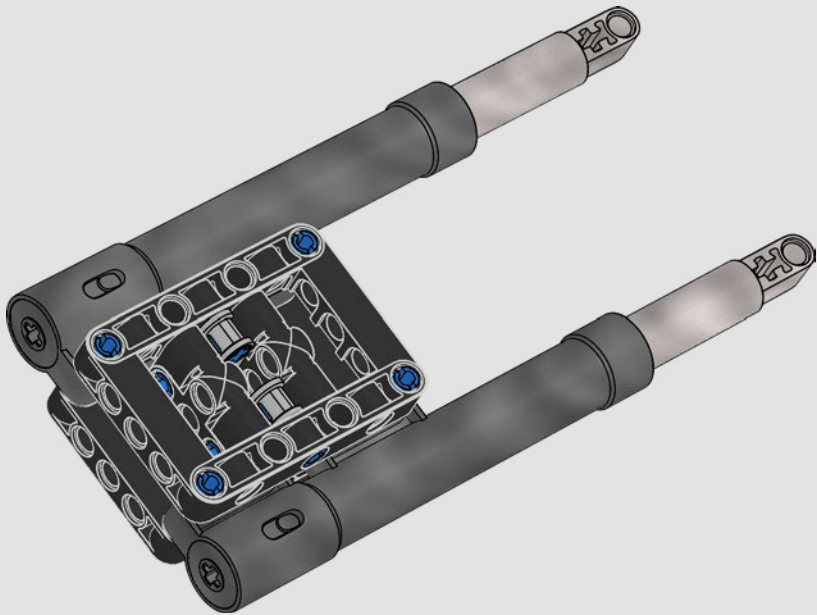

362

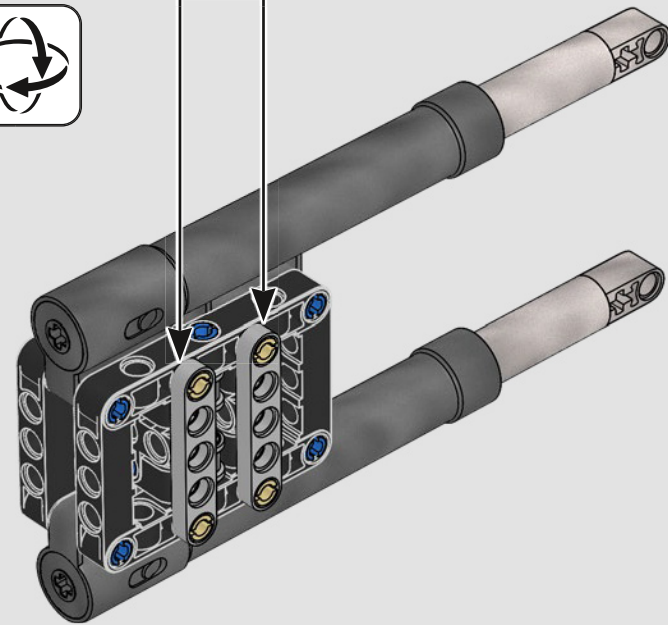
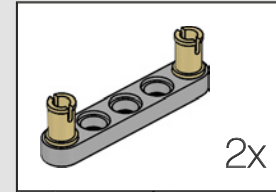

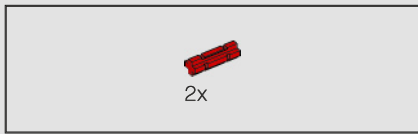

363

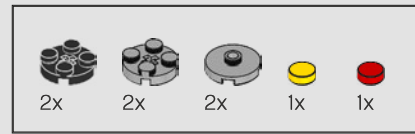
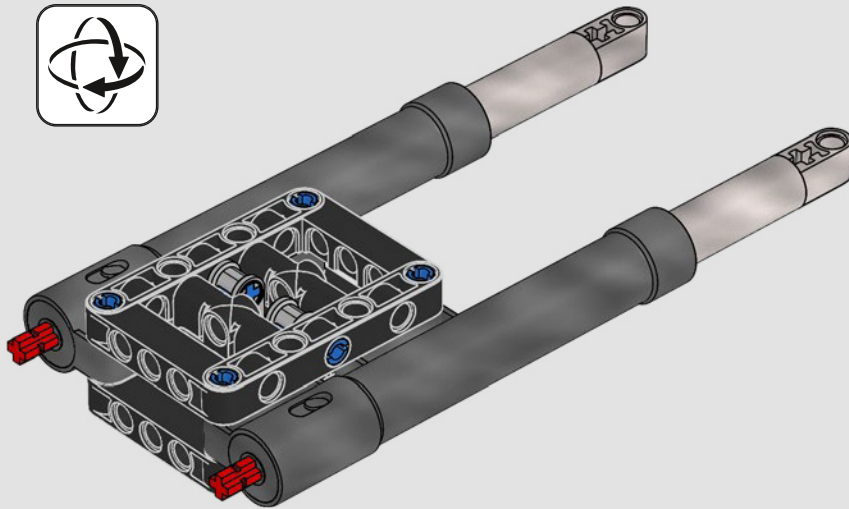

364

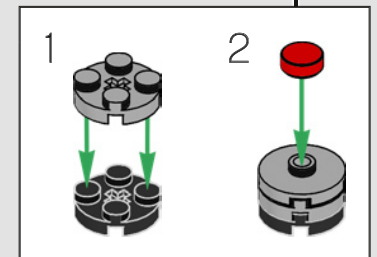
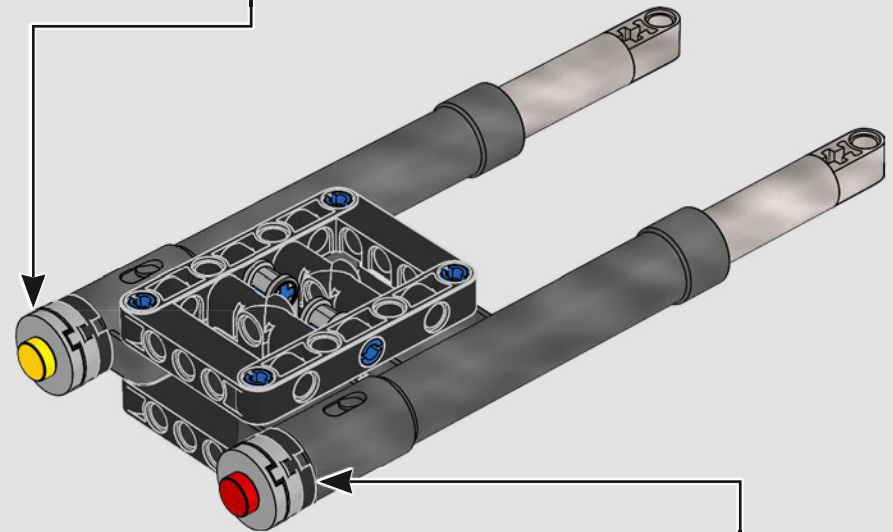
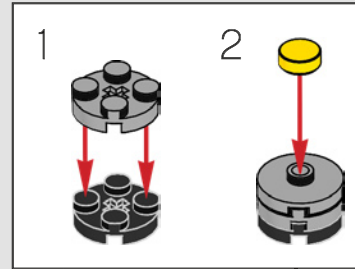



2x

365

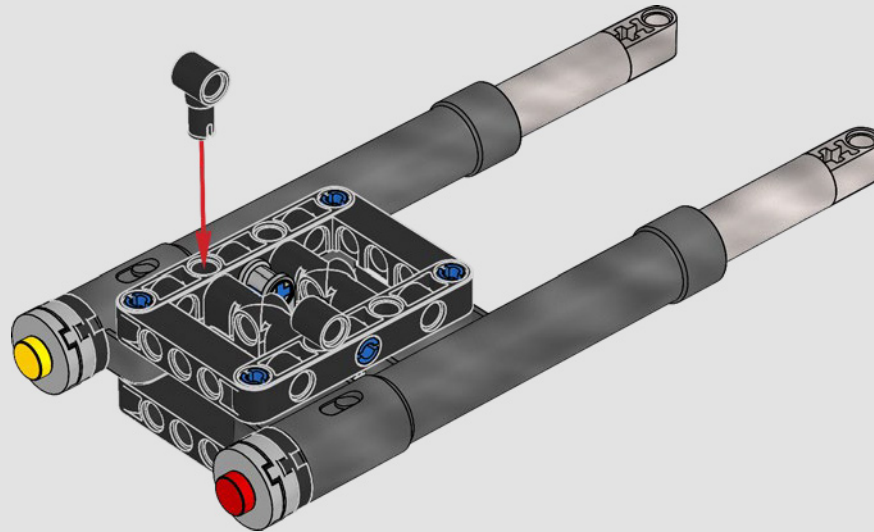

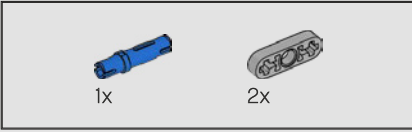
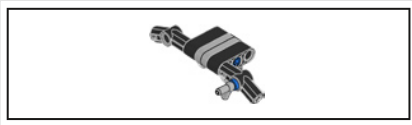

366

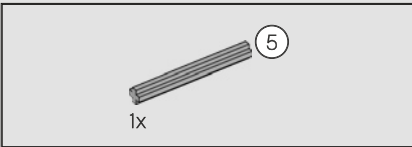
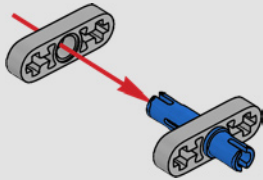

367

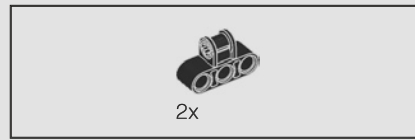
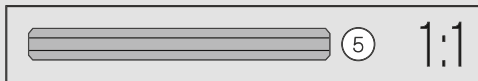
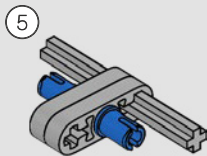

368

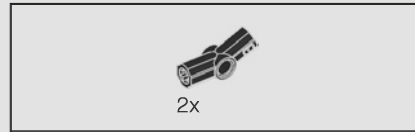
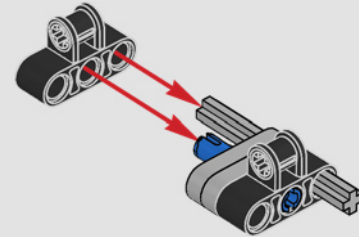

369

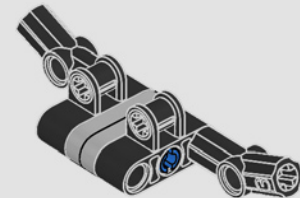

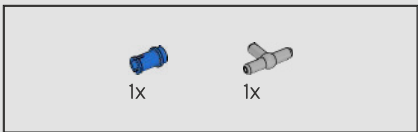

370

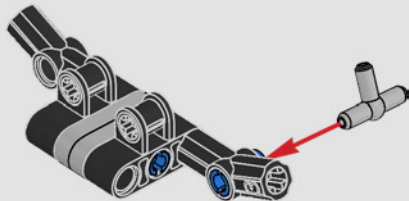

371

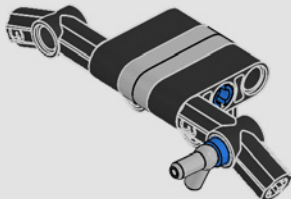

372

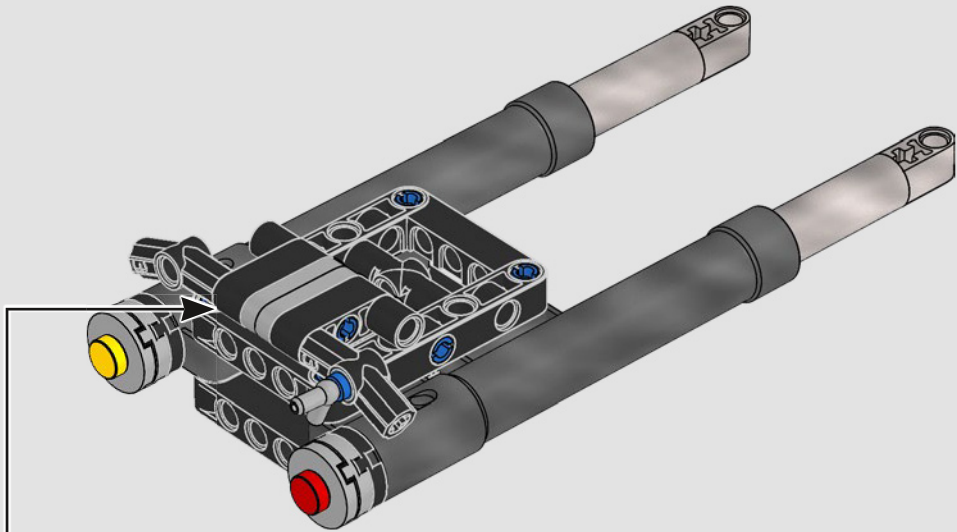

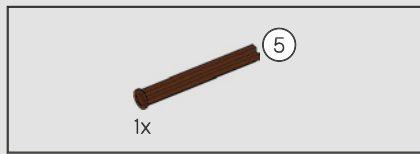

373

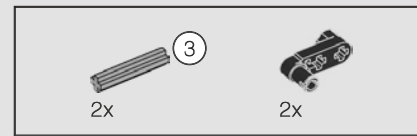
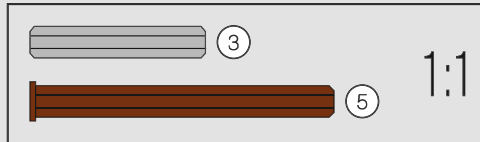
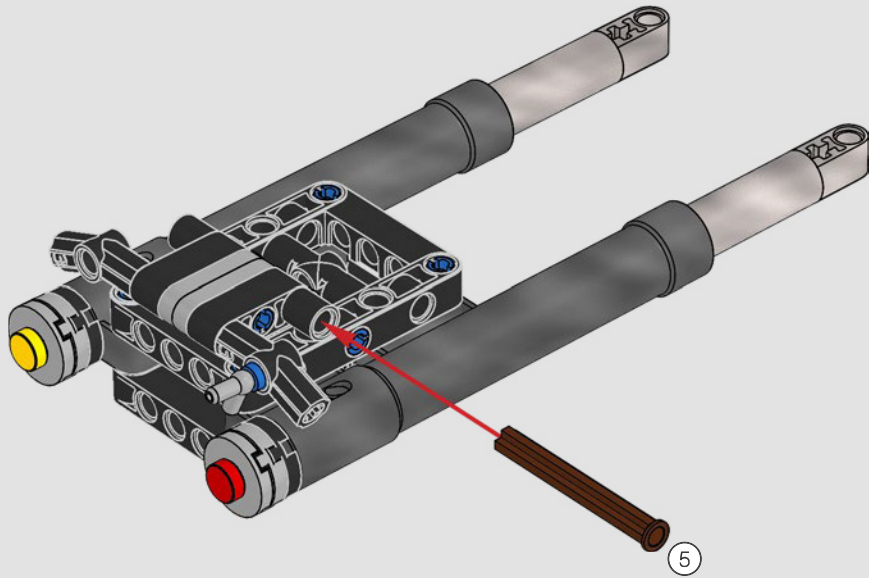

374

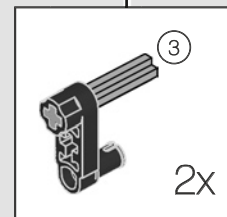
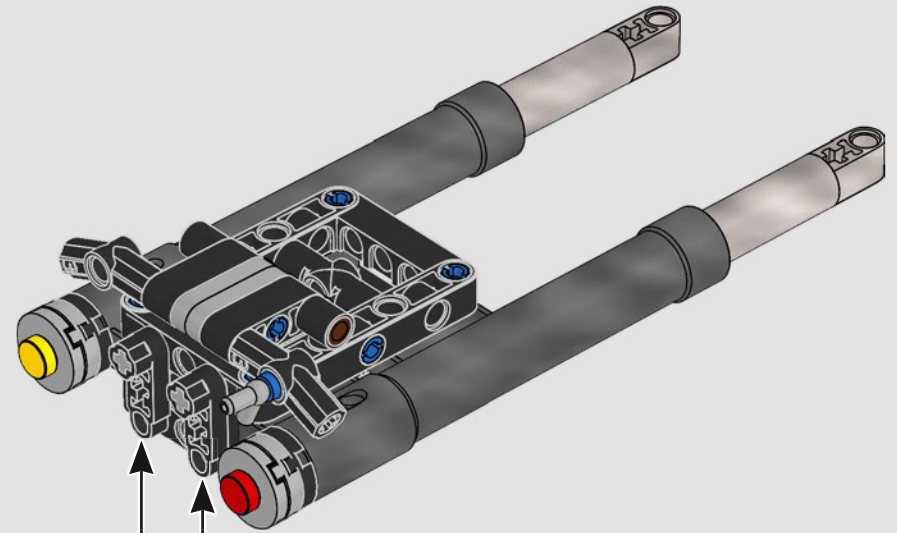

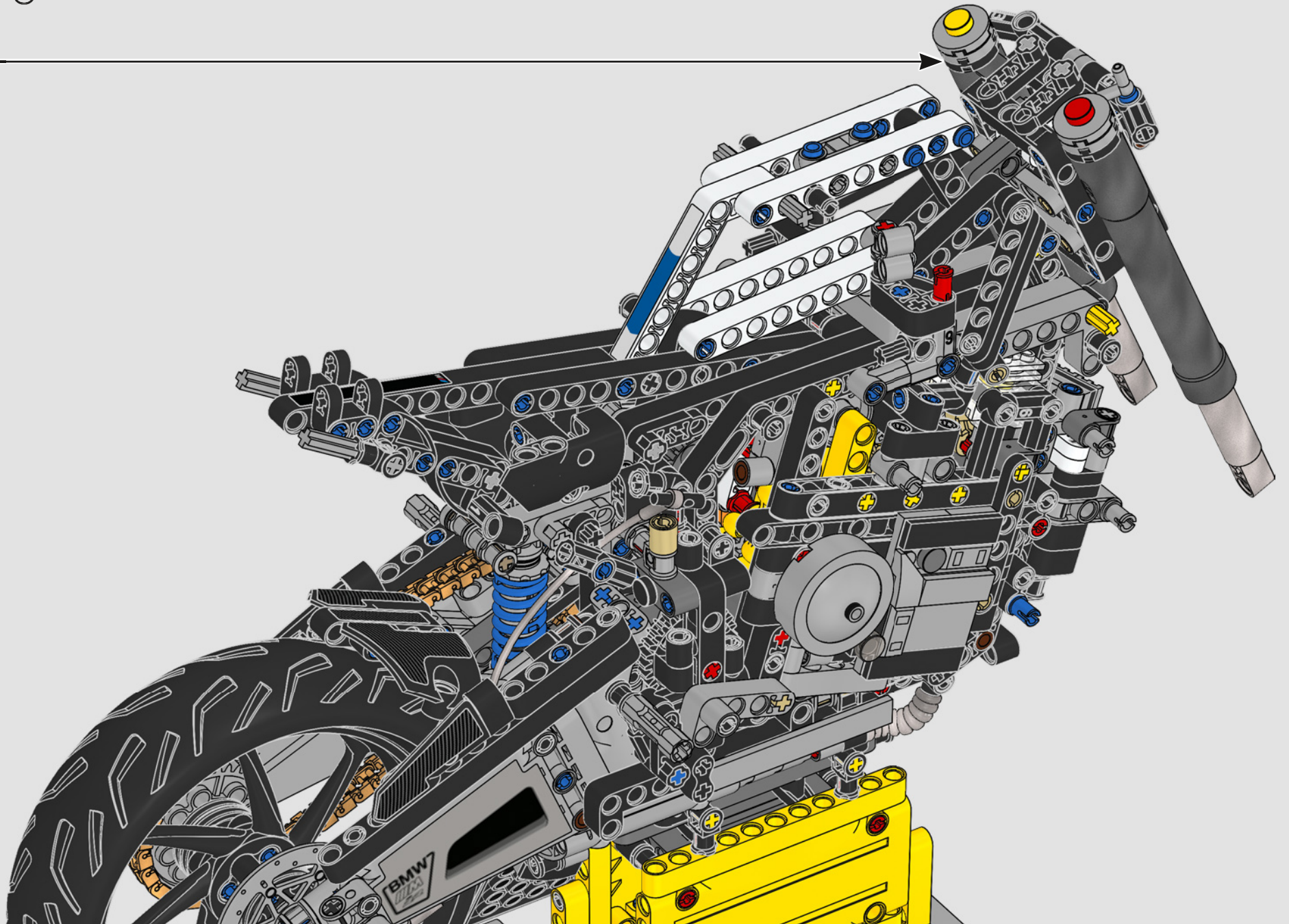

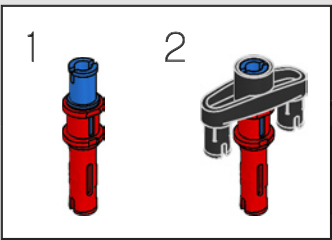
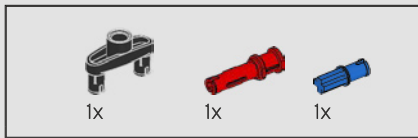

376

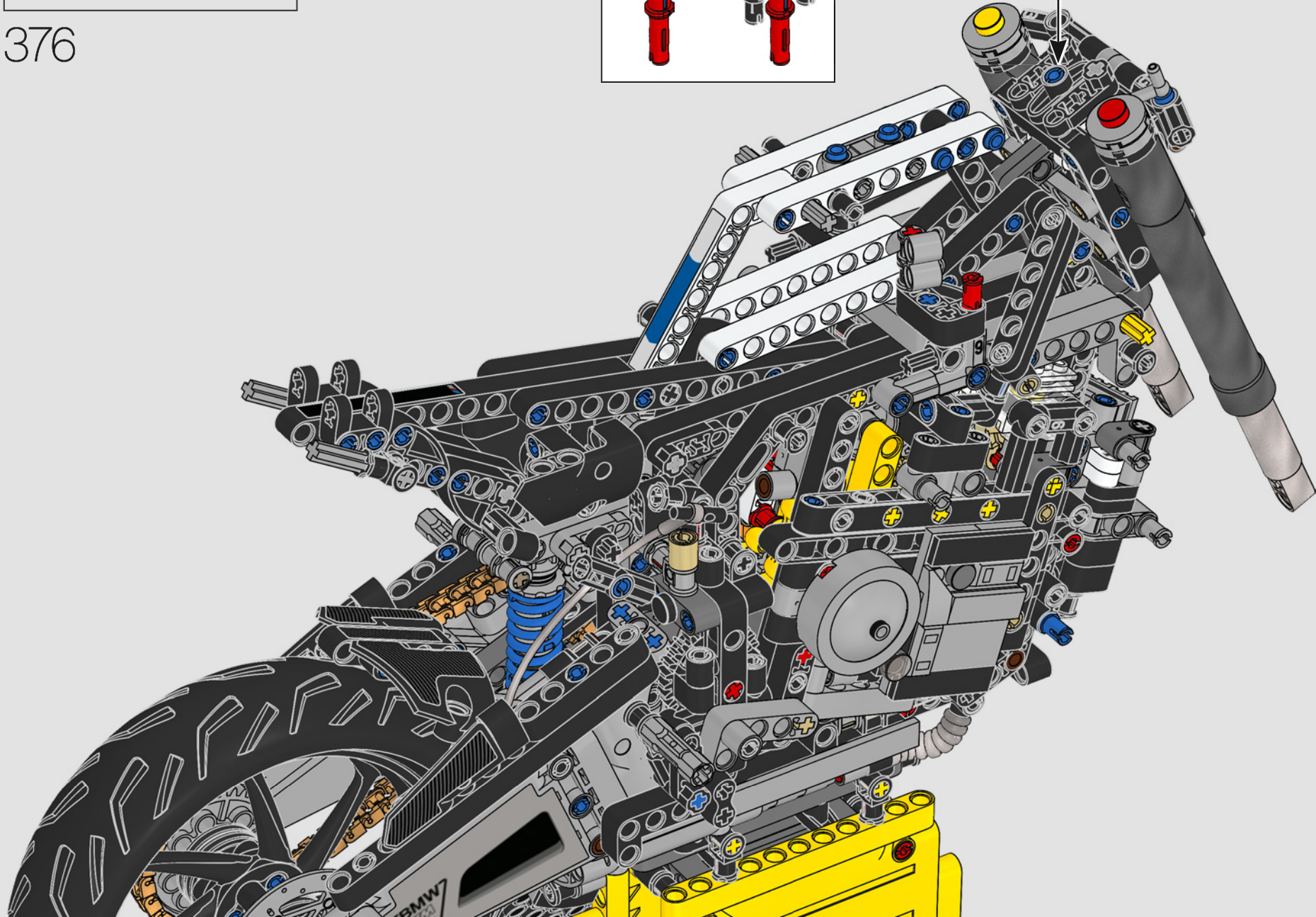

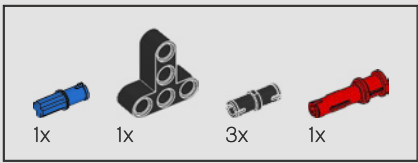

377

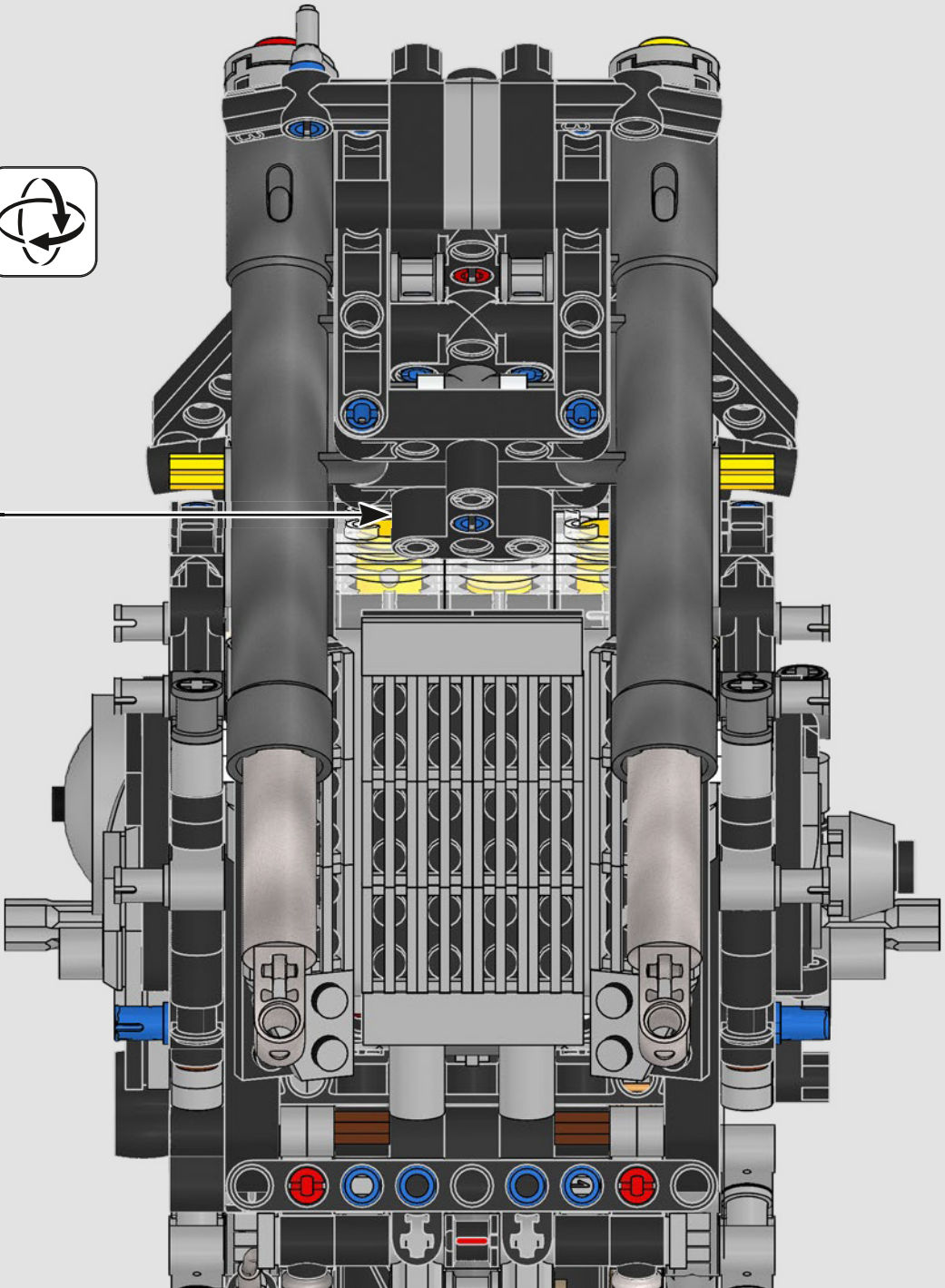
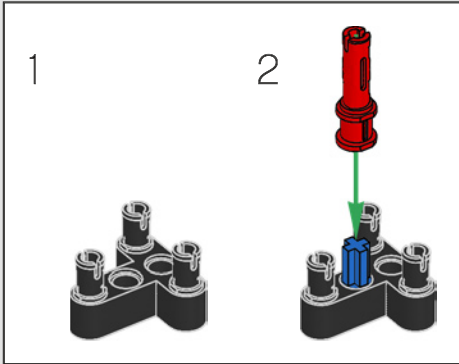

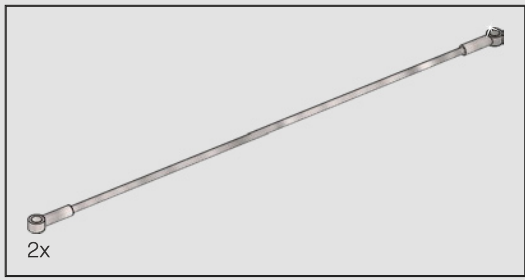

378

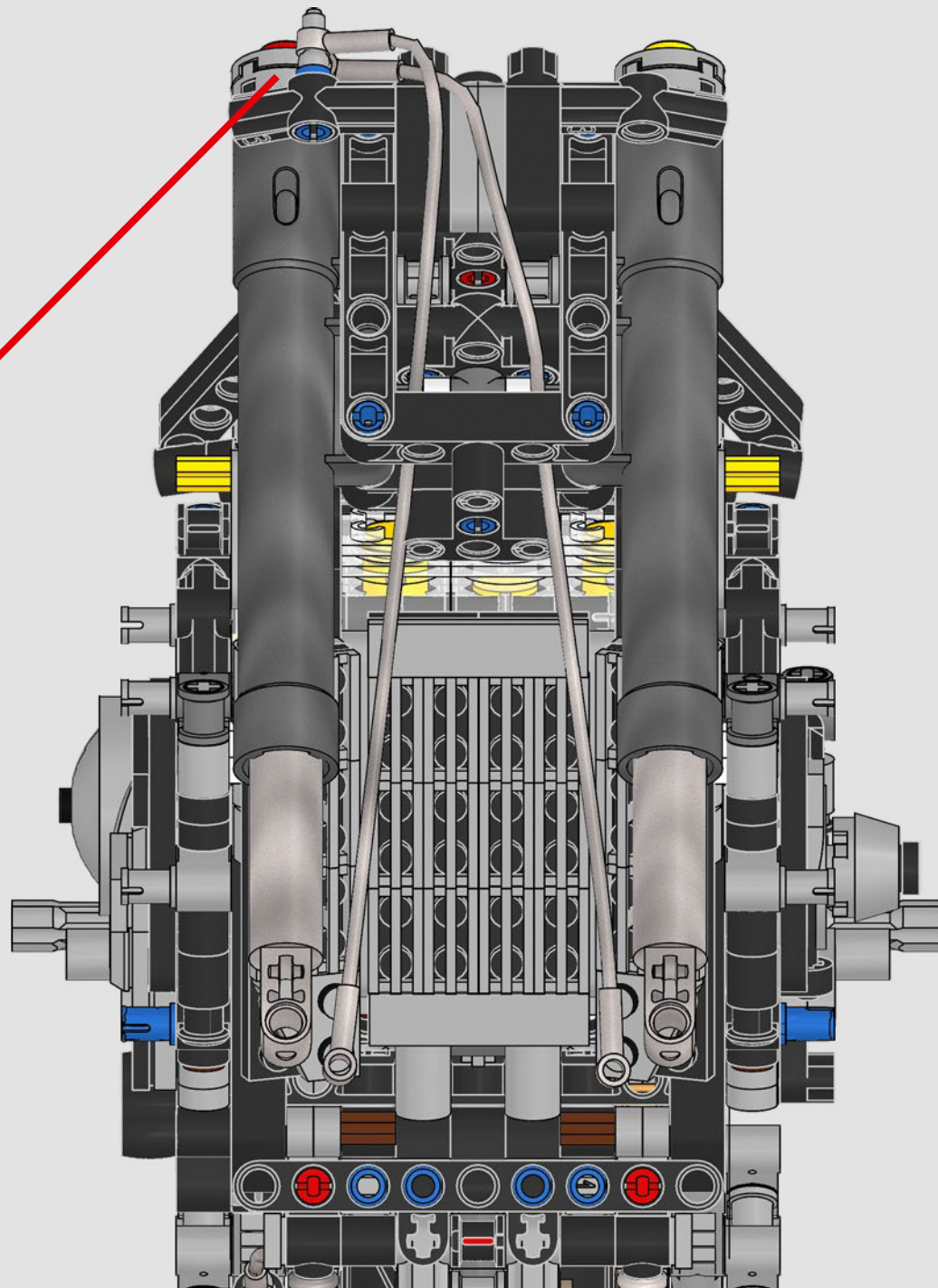
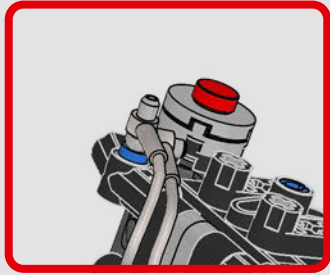

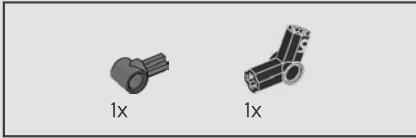
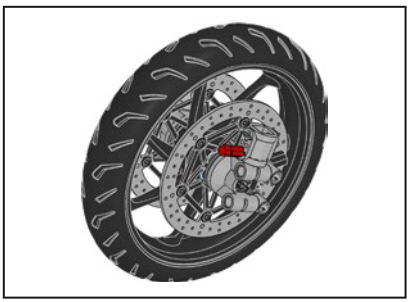

379

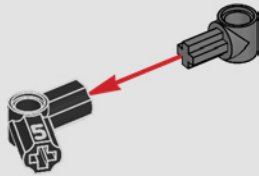

380



381

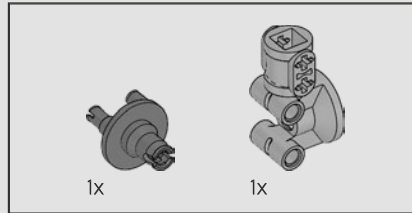
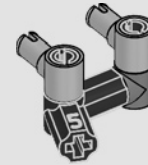

382

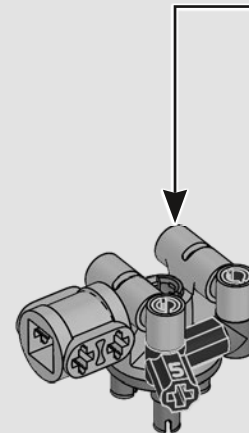
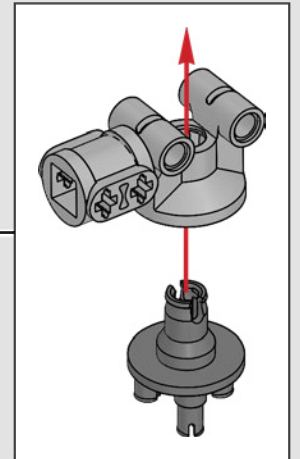

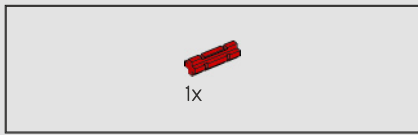

383

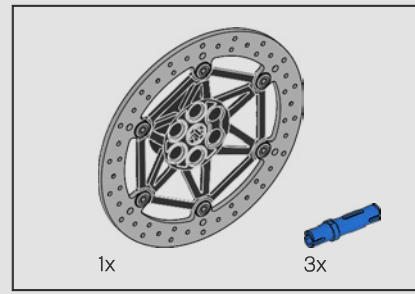
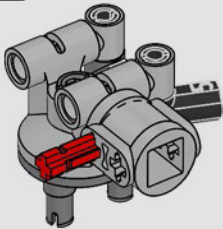

384

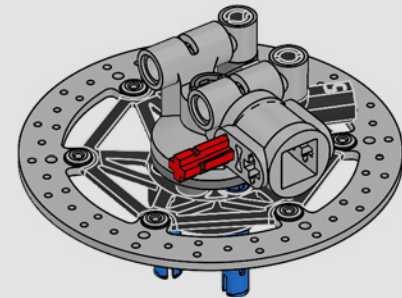
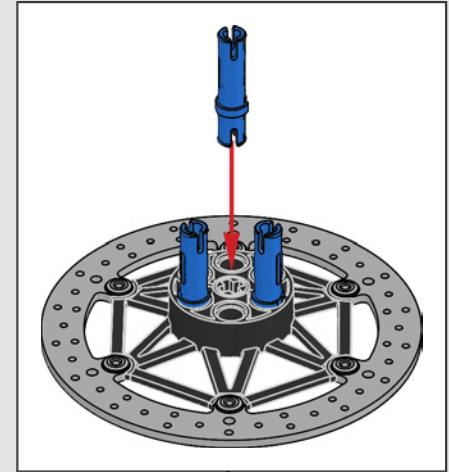

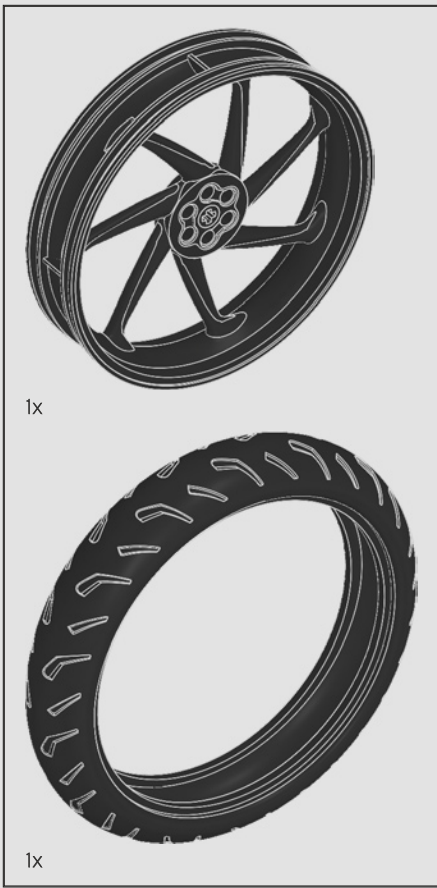

1x

1x

385

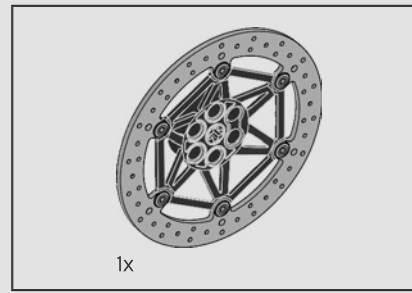
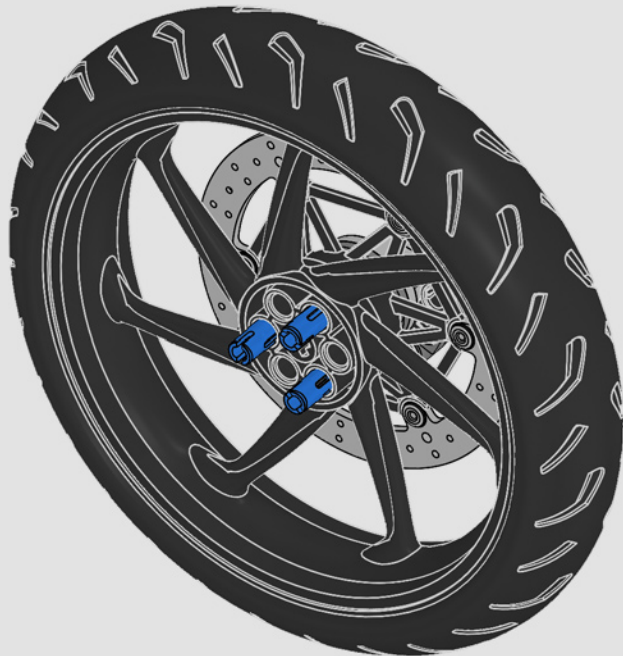

1x

386



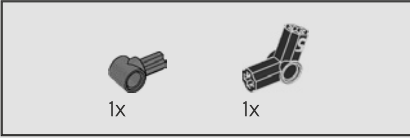
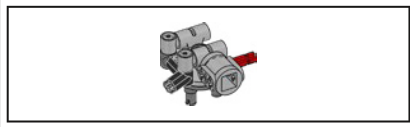

387

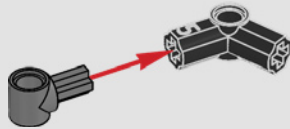

388

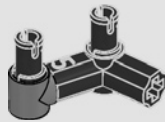

389

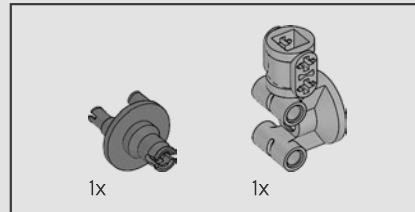
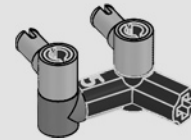

390

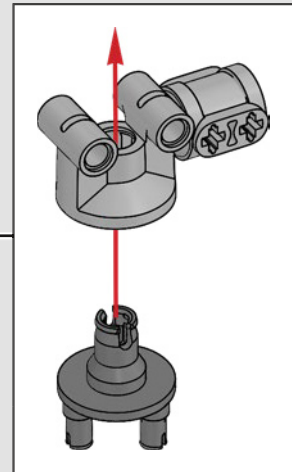
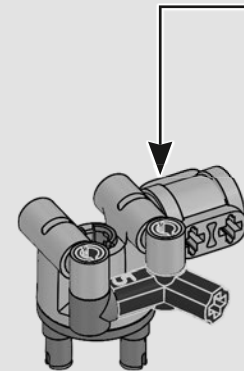



1x

391

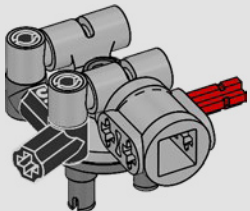

392

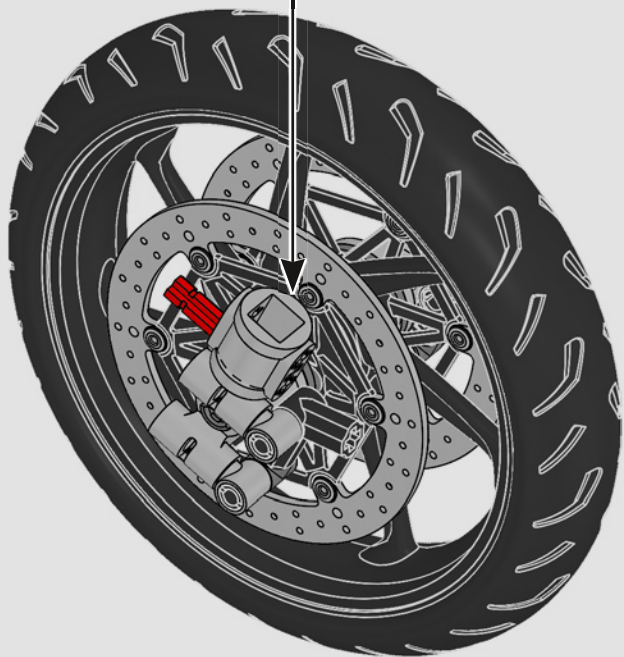

393

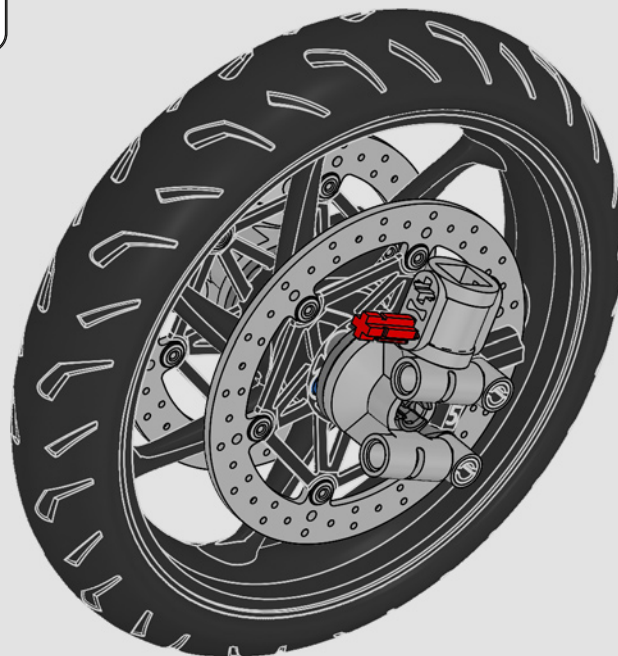

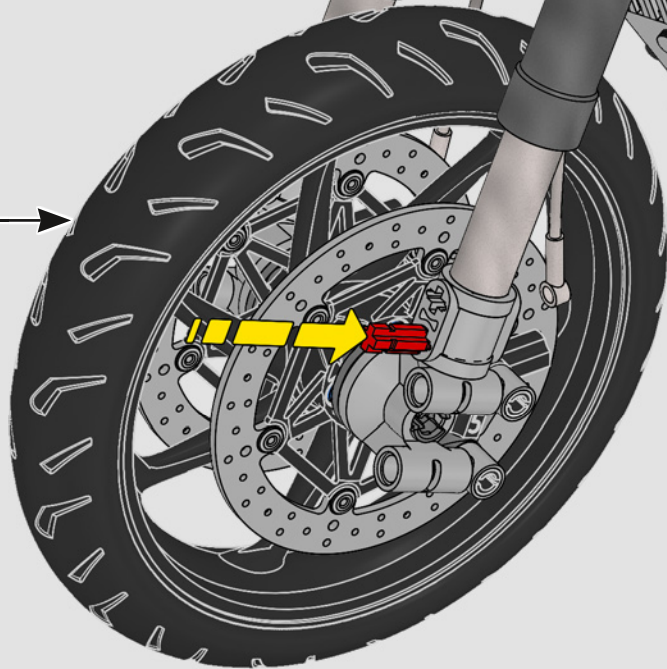
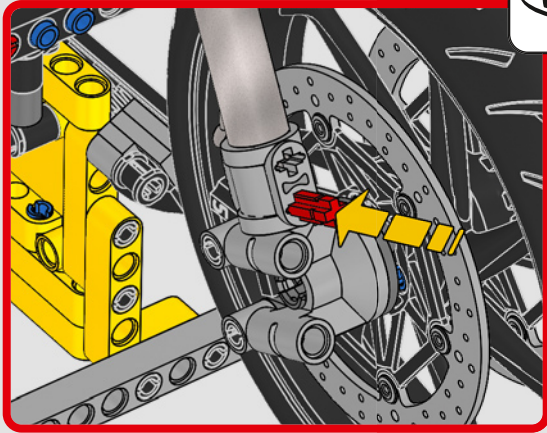

BMW MOTORRAD

M 1000 RR

Power:	212 HP
Nmax:	15,100 rpm
Torque:	115 Nm
CC	999
Ymax.	306 km/h
Acceleration	325 km/h (<math>< 3.1 \text{ sec.}</math>)
Weight: Din	0-100 km/h <math>< 7.3 \text{ sec.}</math>
Downforce	0-200 km/h <math>< 7.3 \text{ sec.}</math>
	192 kg
	Winglet 16,3 kg

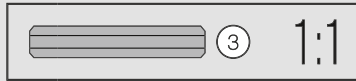
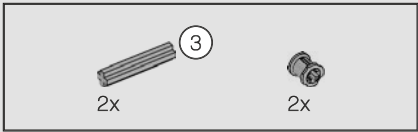

395

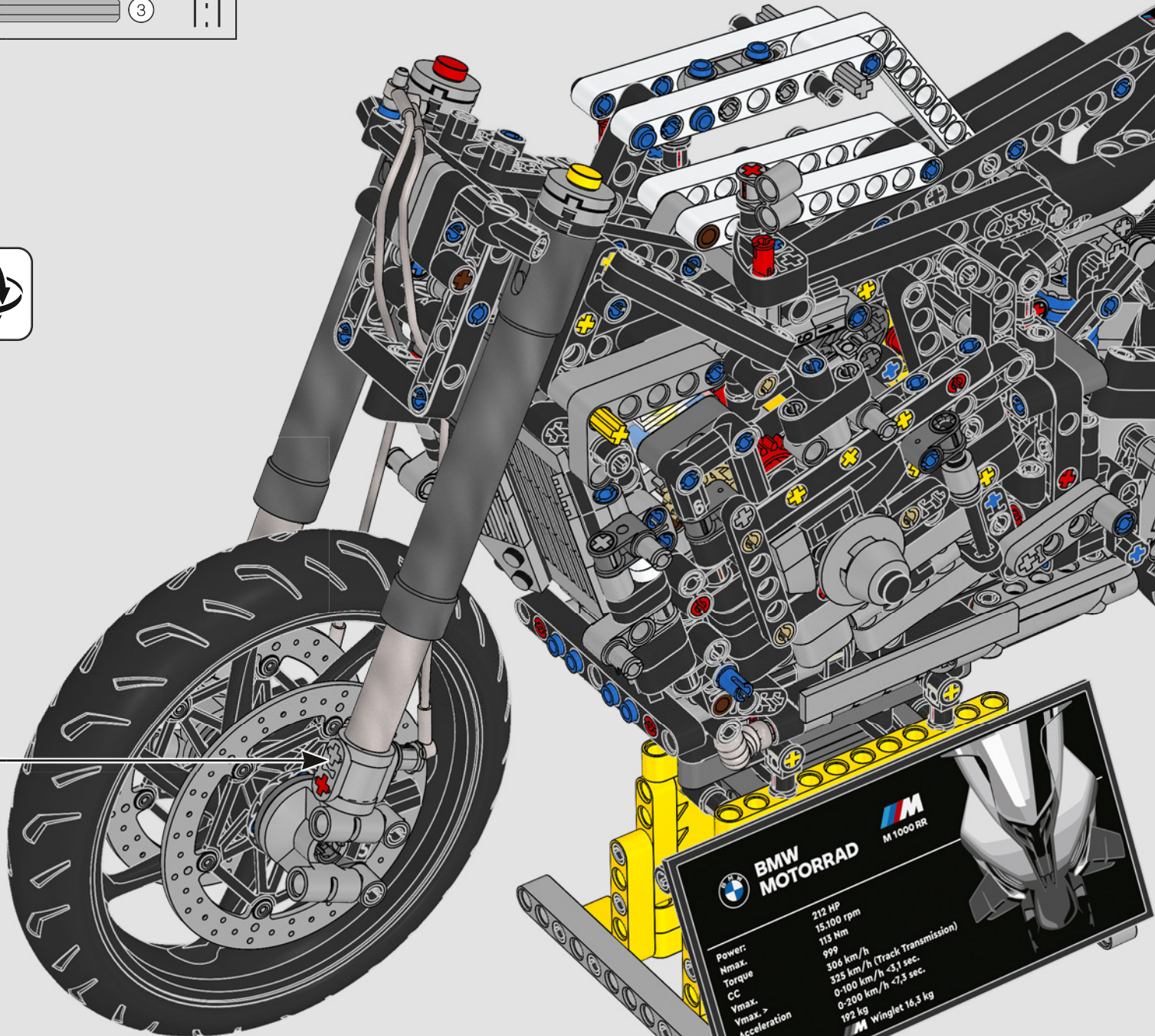
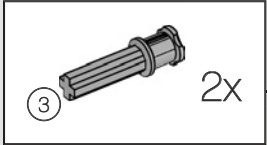
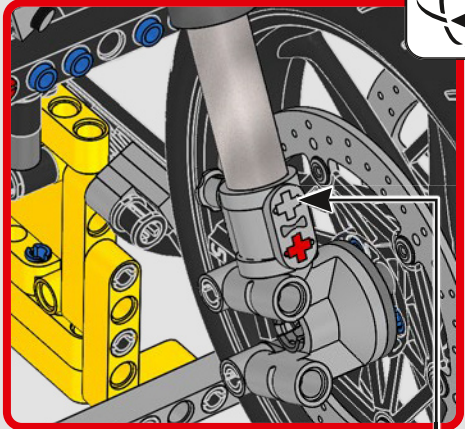

BMW	MOTORRAD	M 1000 RR
Power:	212 Hp	
Nmax:	15.100 rpm	
Torque:	113 Nm	
CC:	999	
Vmax:	306 km/h	(Track Transmission)
Vmax. >	325 km/h	<3> sec.
Acceleration	0-200 km/h	<7,3 sec.
Weight Din	192 kg	
Force		Winglet 16,3 kg



396



397

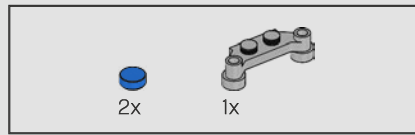

398

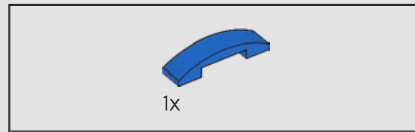
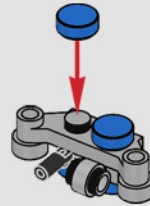

399

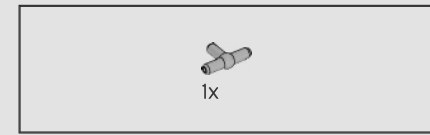
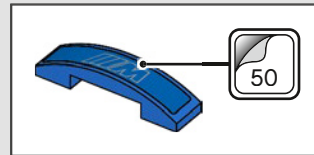

400

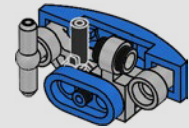
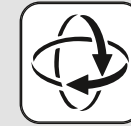

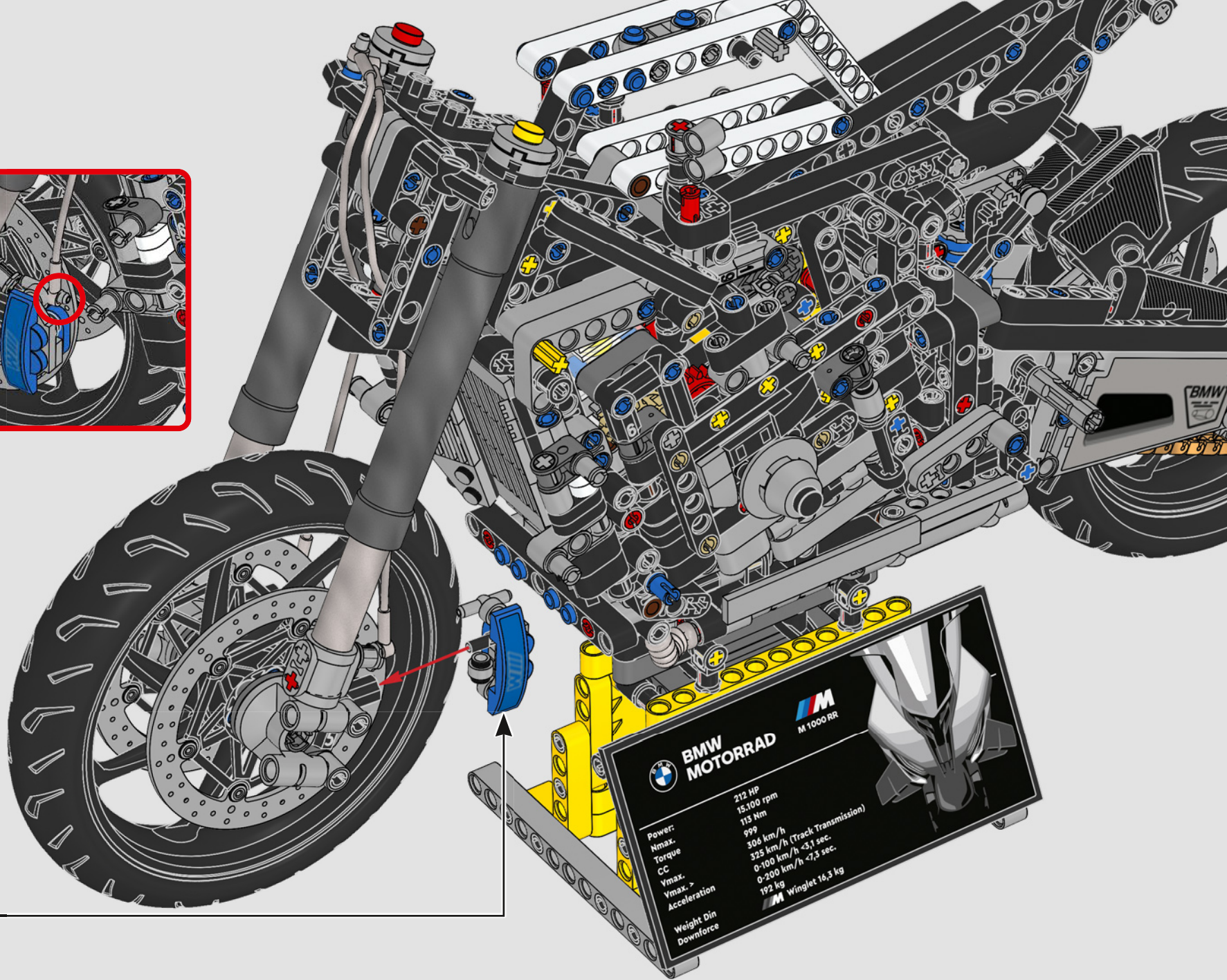
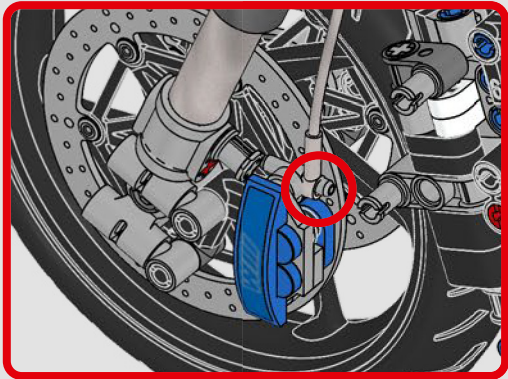

BMW MOTORRAD M 1000 RR

Power:	212 HP
Nmax:	15,100 rpm
Torque:	115 Nm
CC	999
Vmax.	306 km/h (Track Transmission)
Acceleration	0-100 km/h <3,1 sec.
	0-200 km/h <7,3 sec.
Weight Din	192 kg
Downforce	Winglet 16,3 kg





402



403

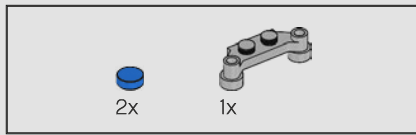

404

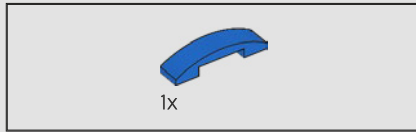
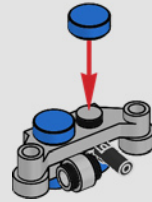

405

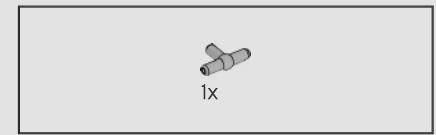

406

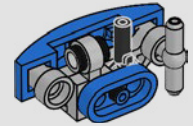

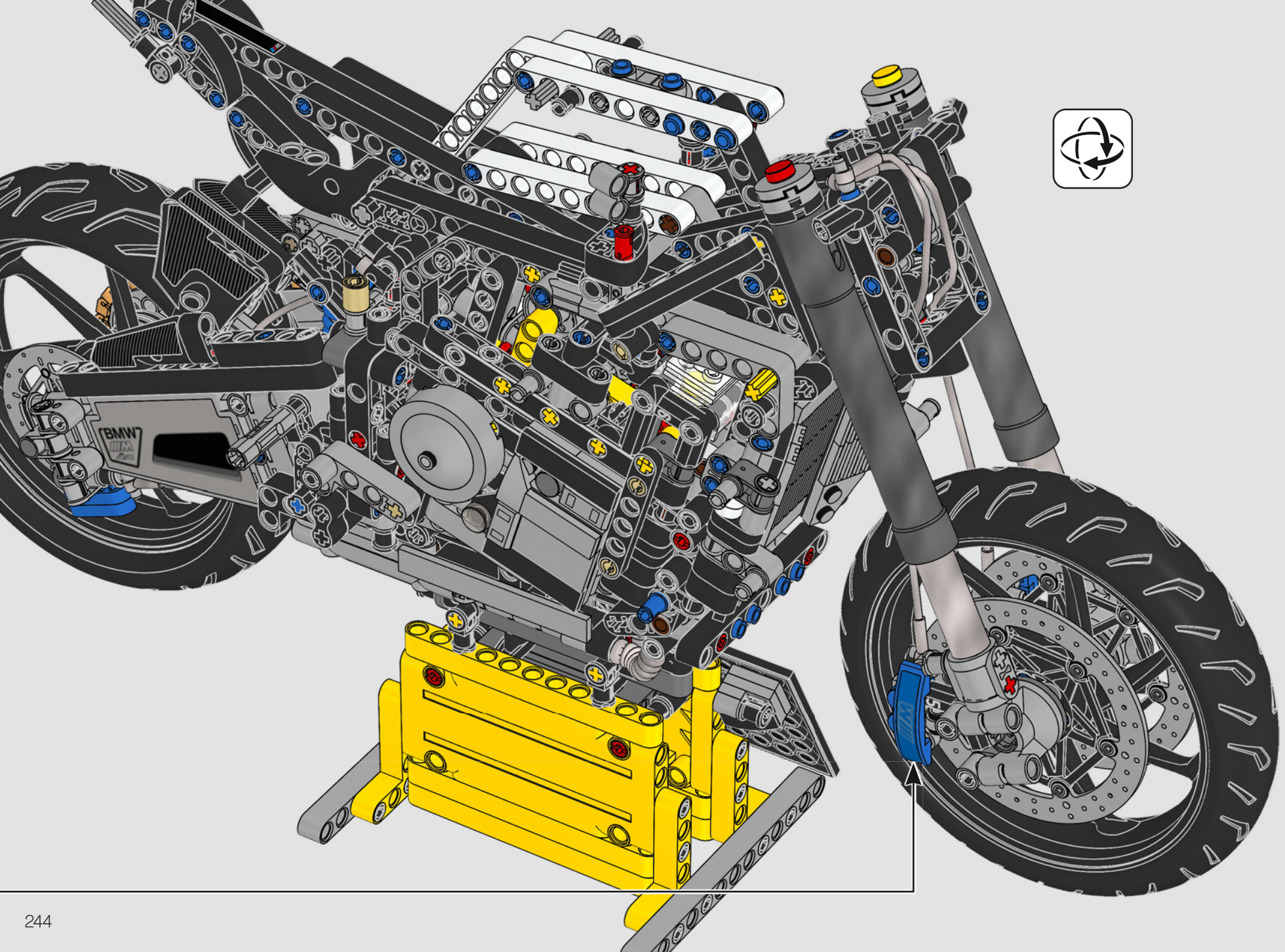

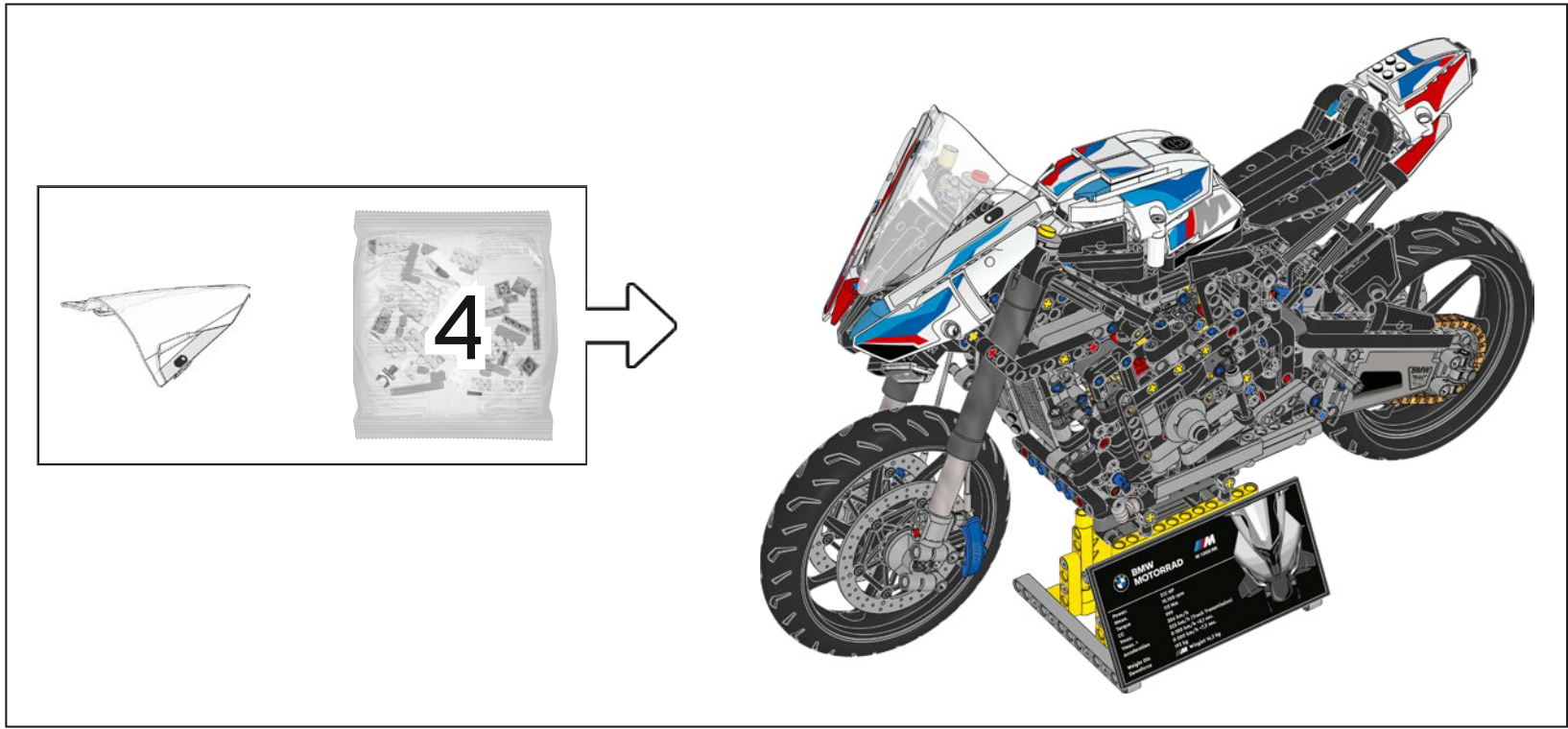

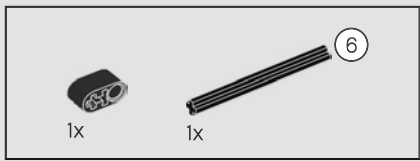

407

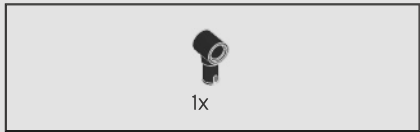
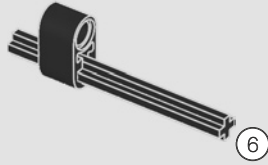

408

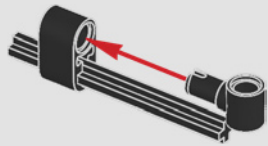

409

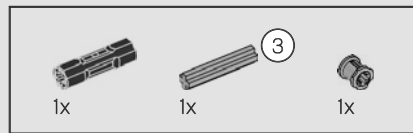
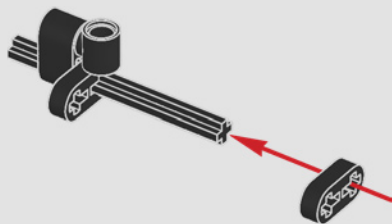

410

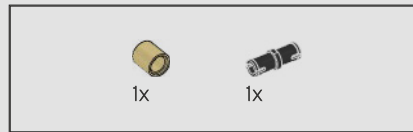
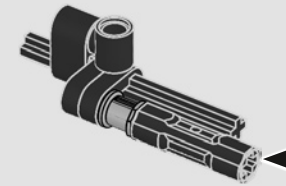
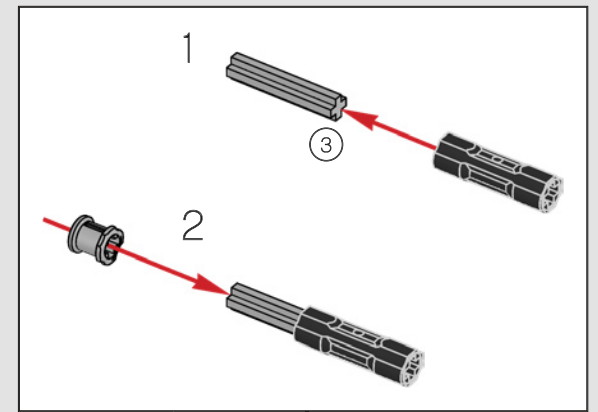

411

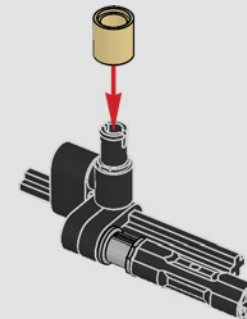

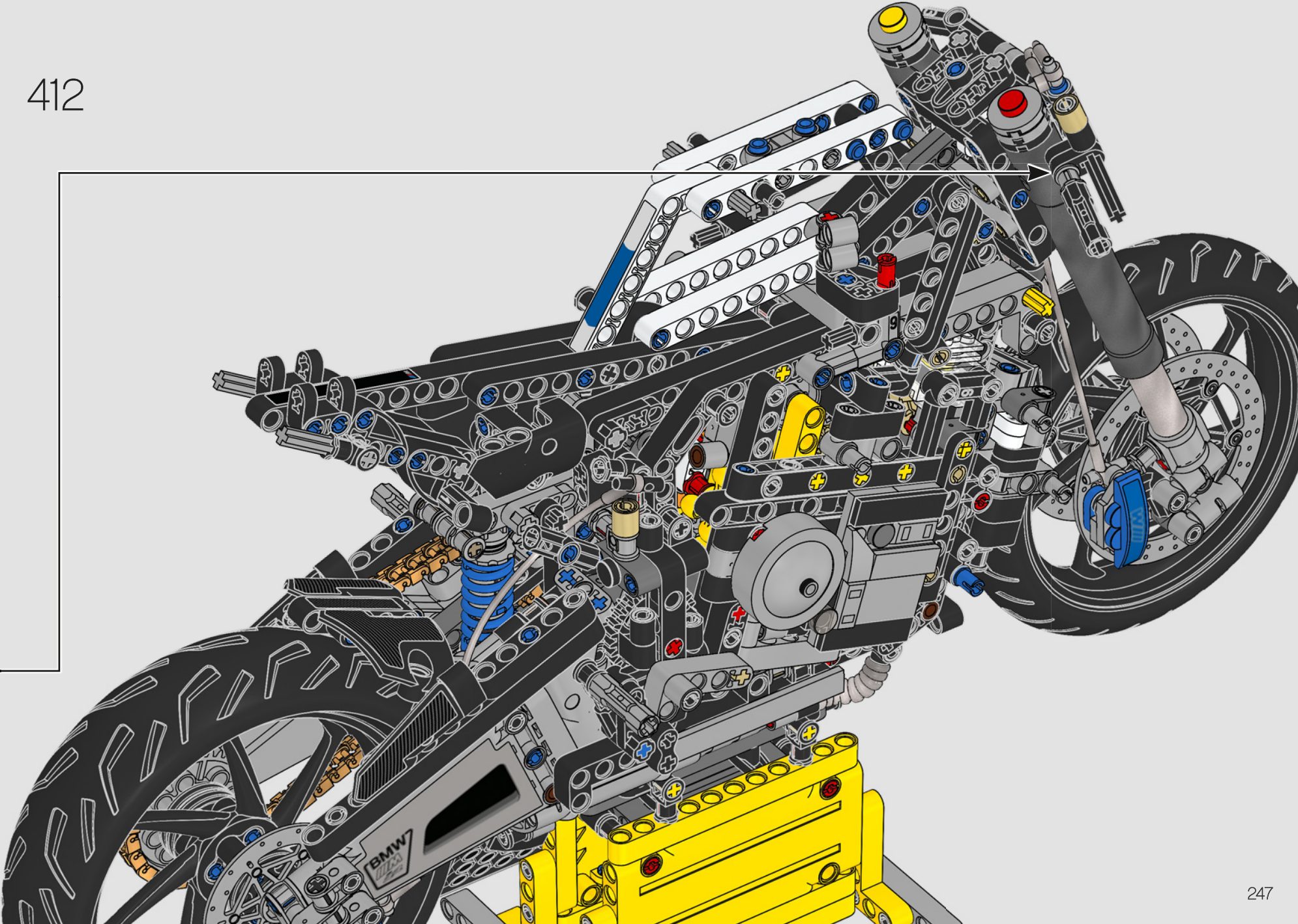

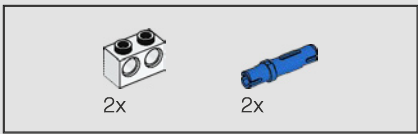

413

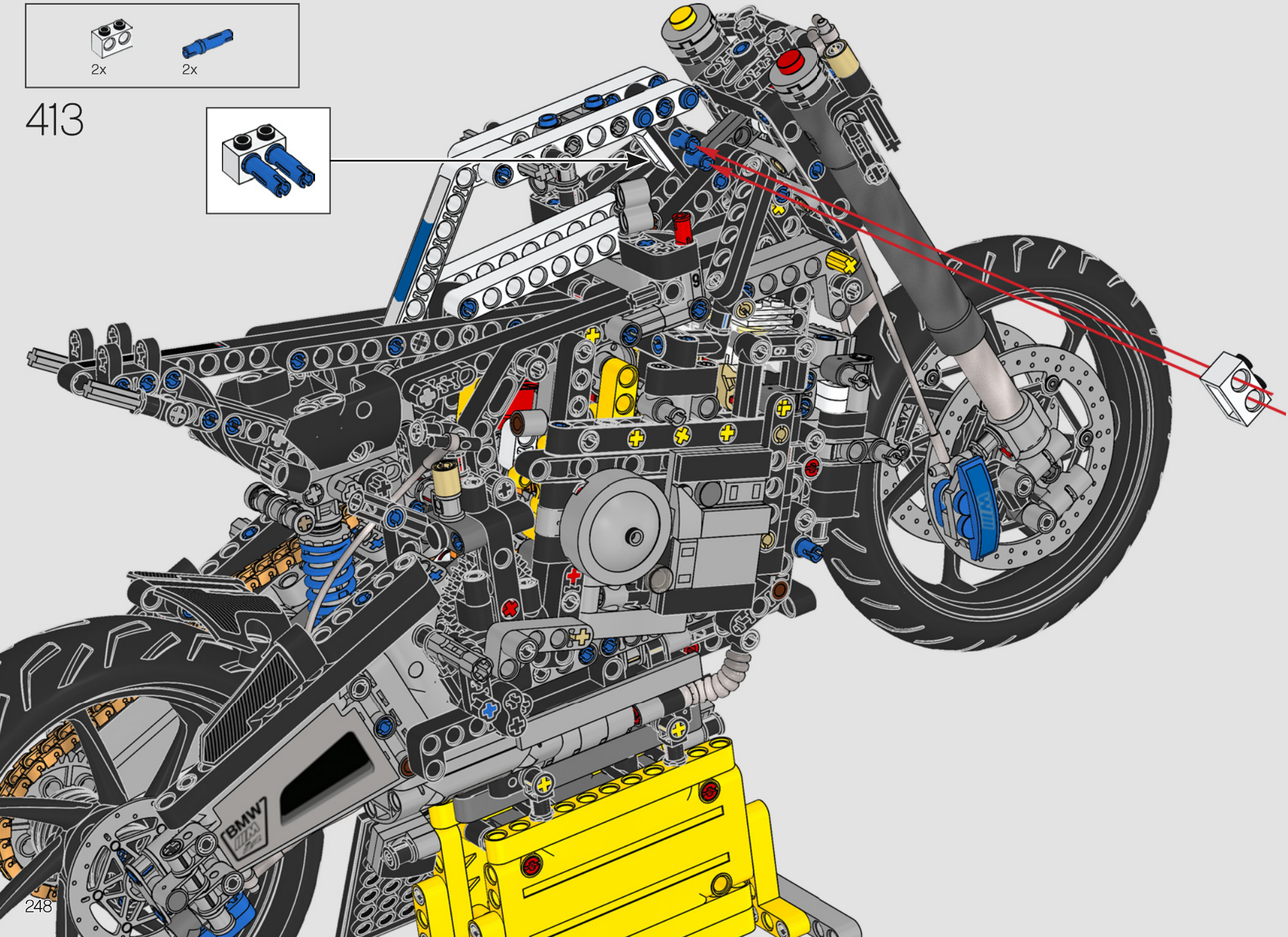
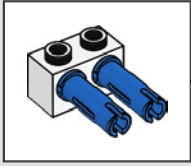

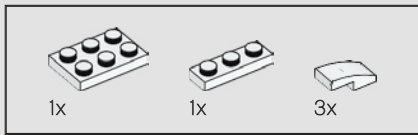

414

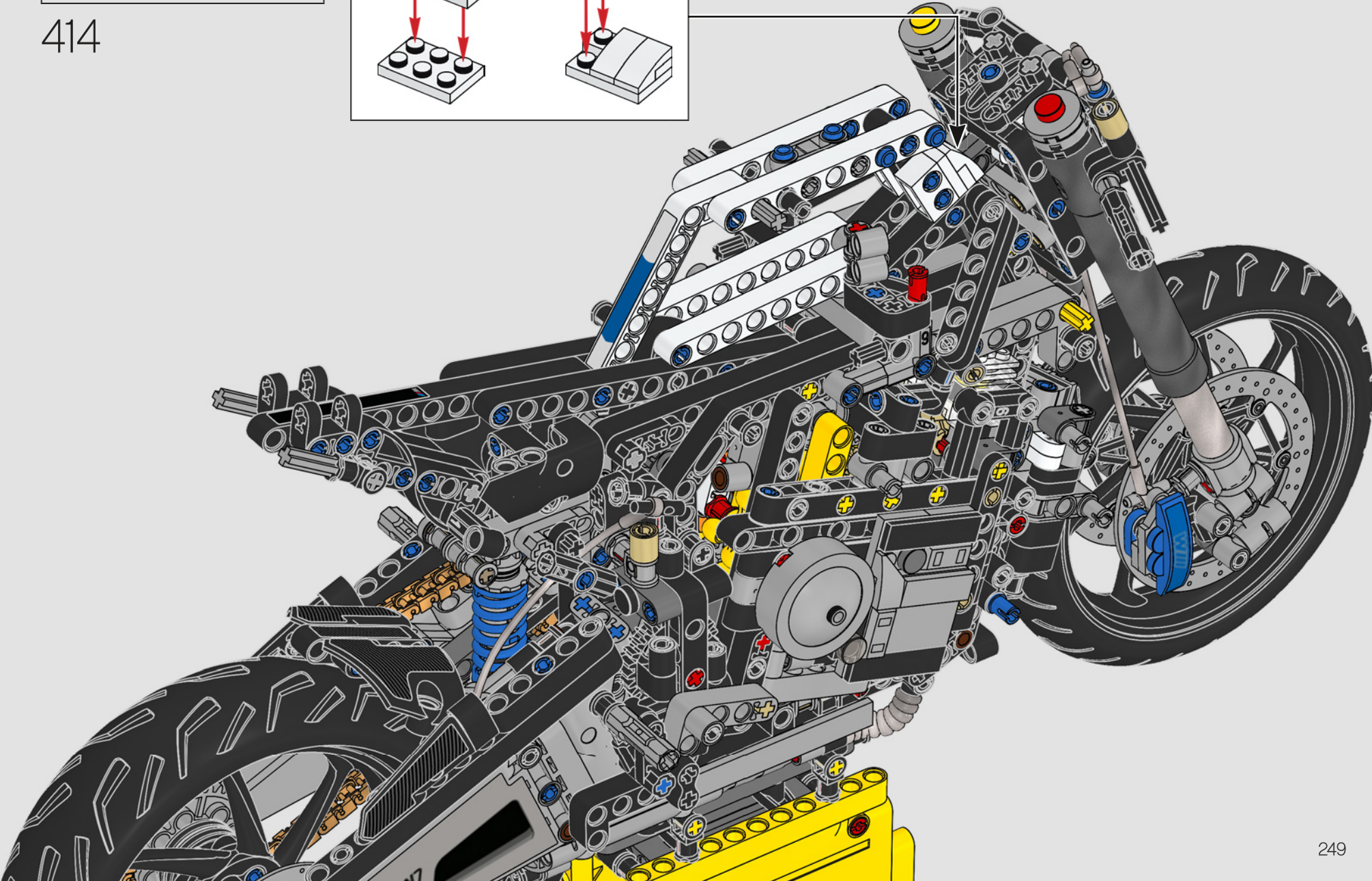
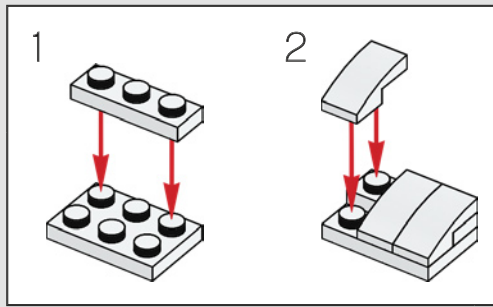

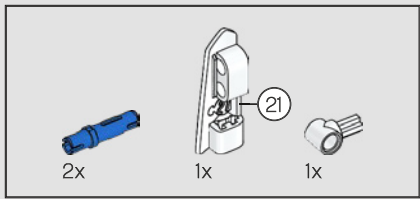

415

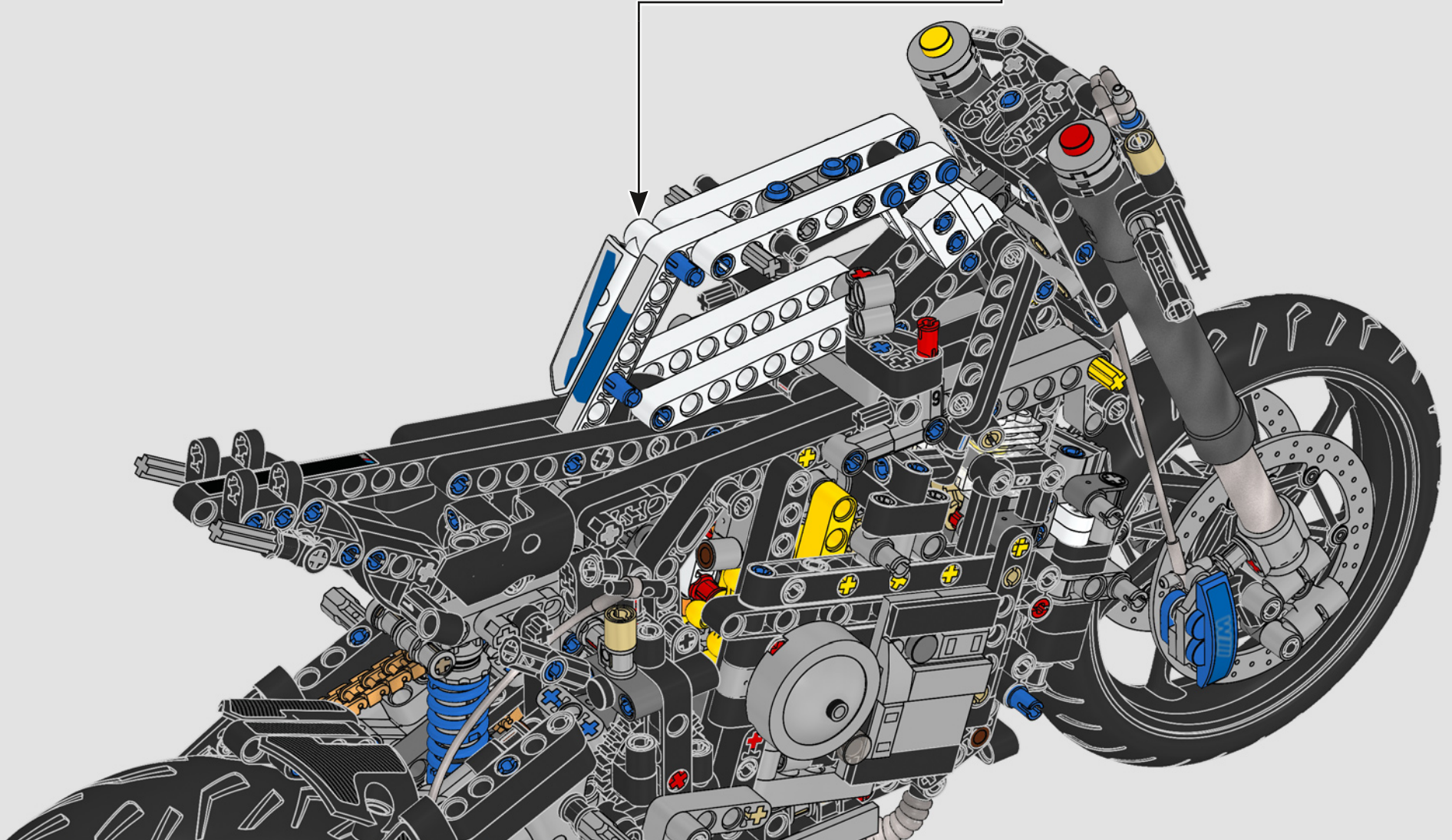
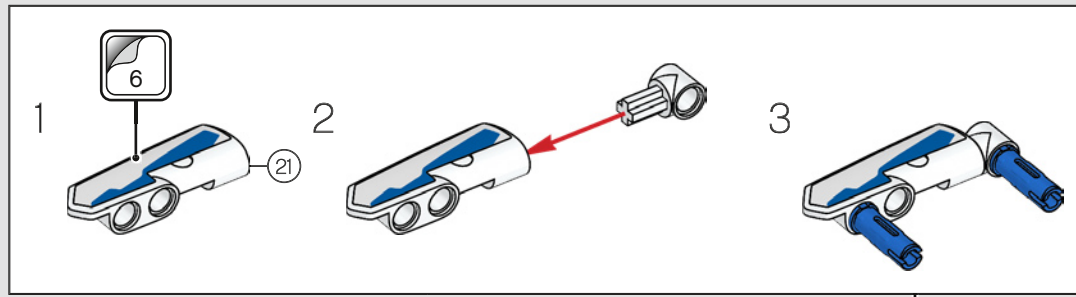

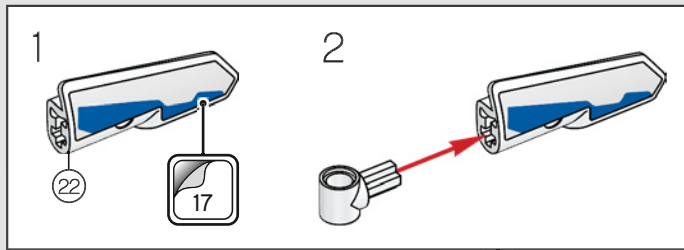
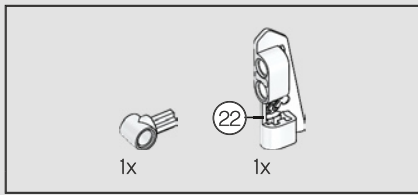

416

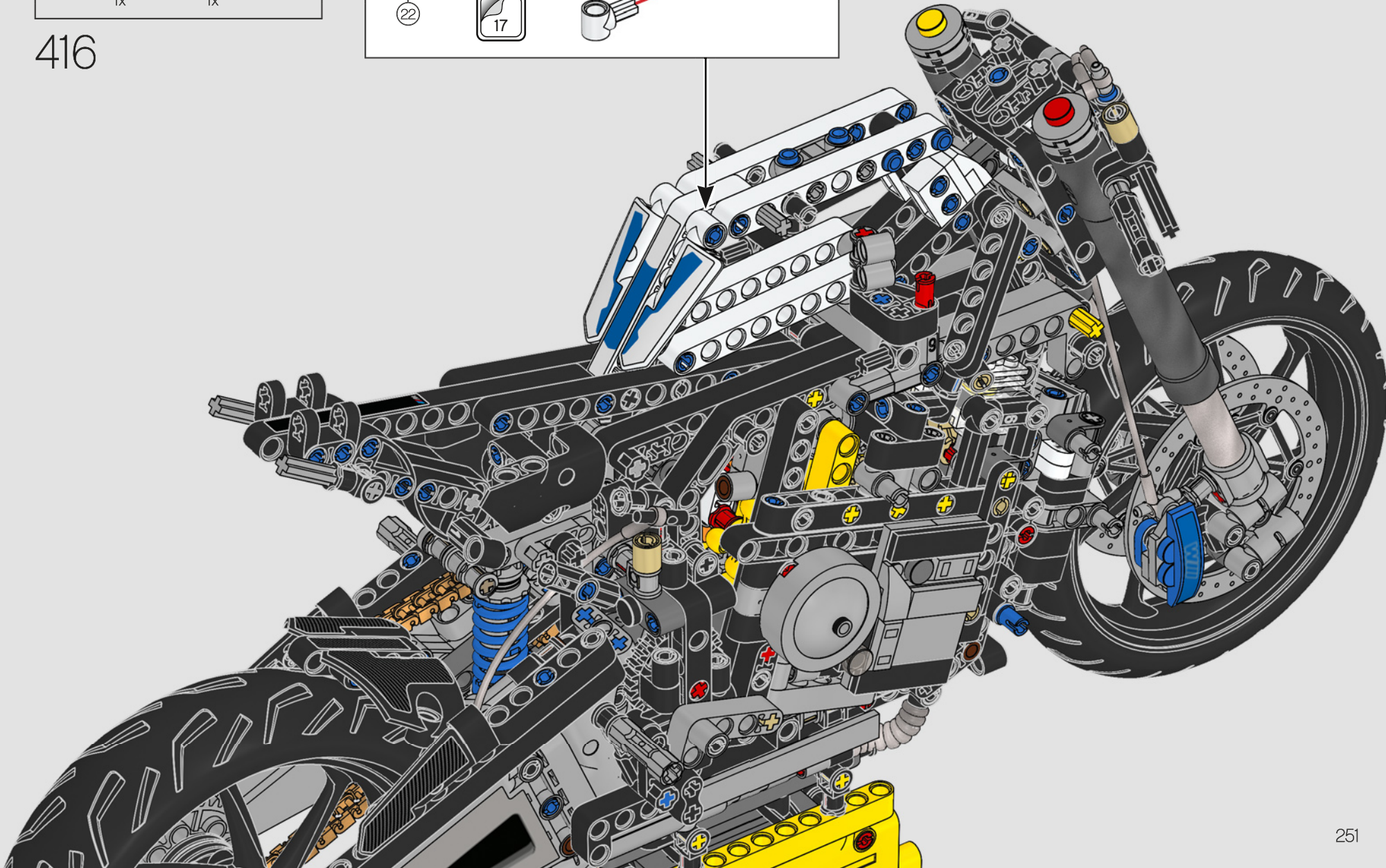

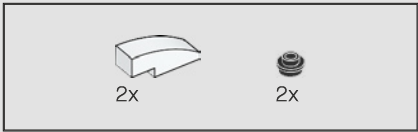

417

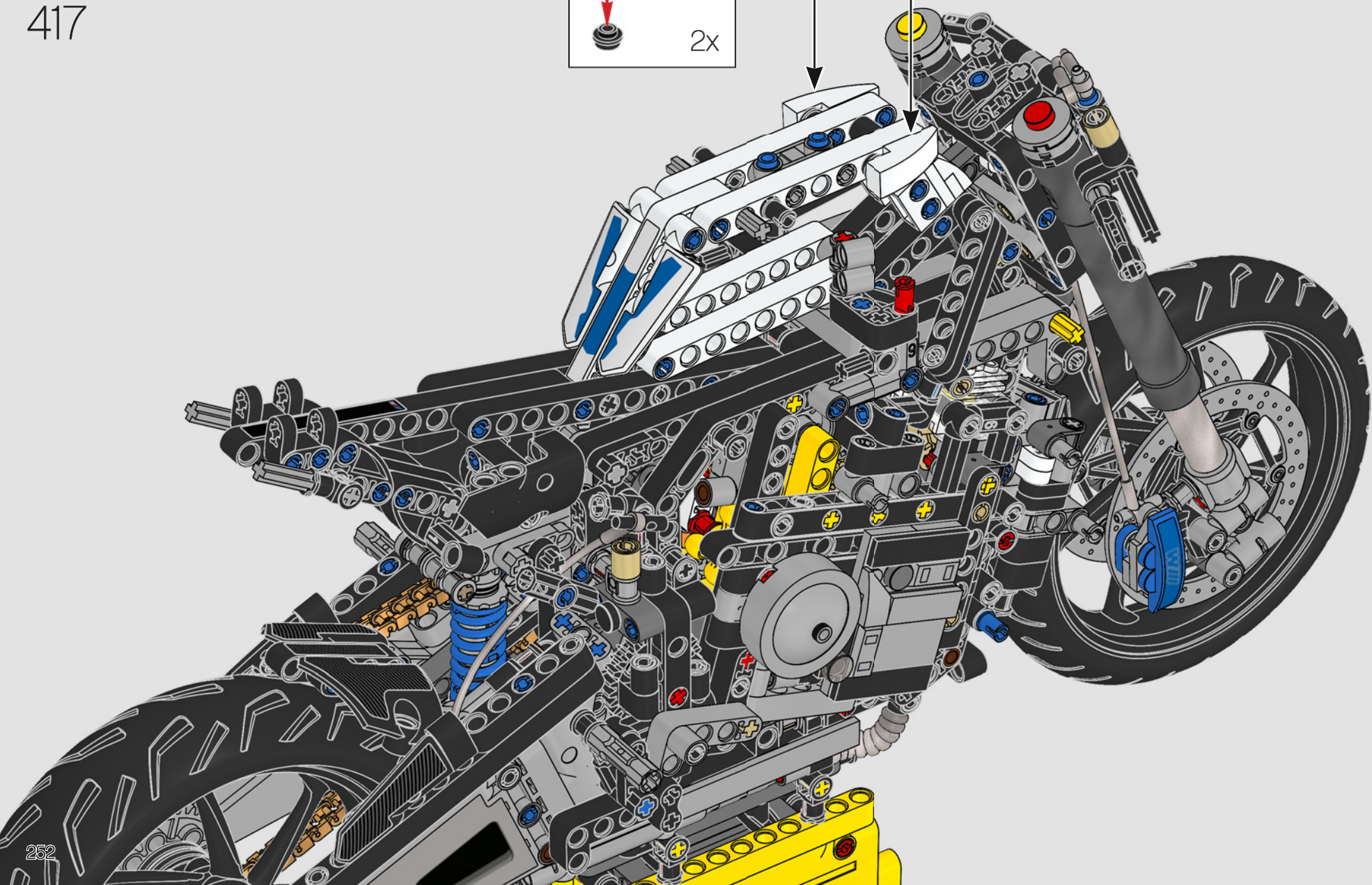
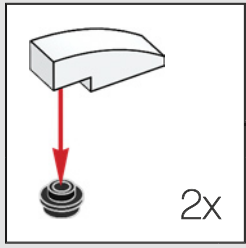



418

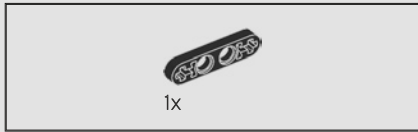

419

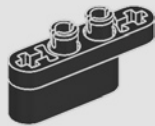

420

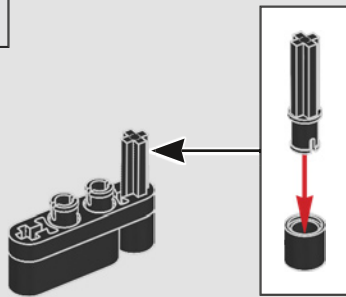

421

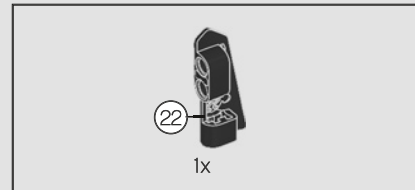
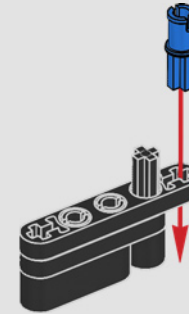

422

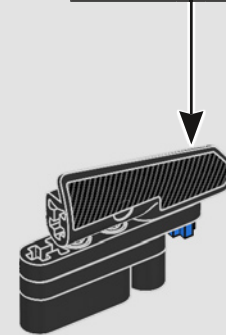
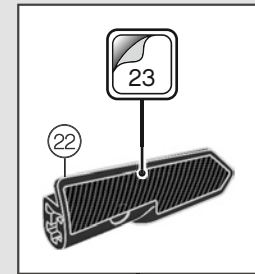

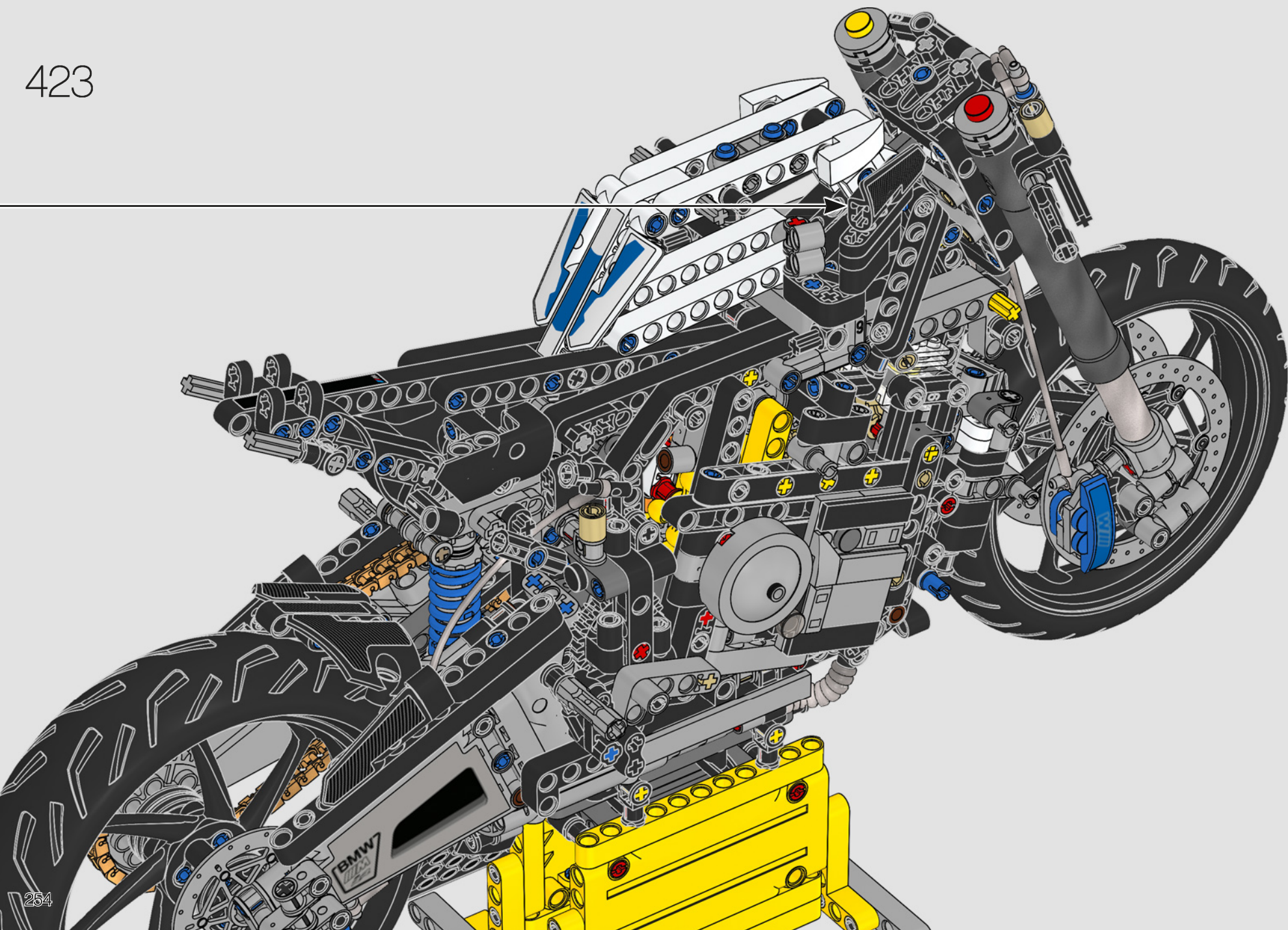

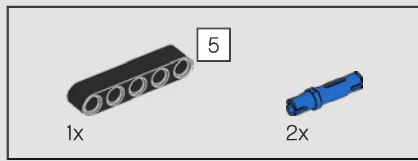

424

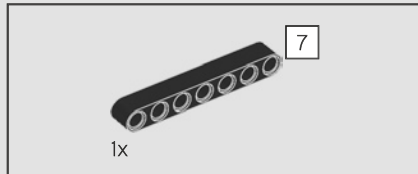
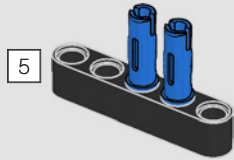

425

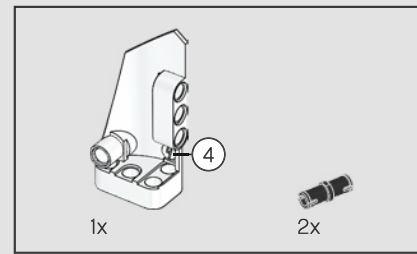
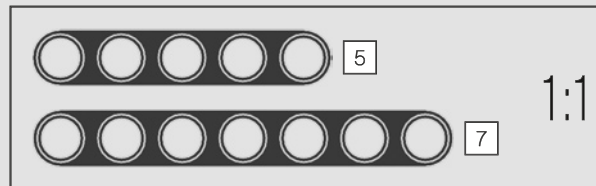
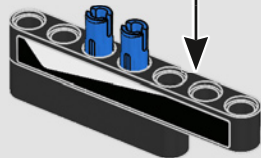
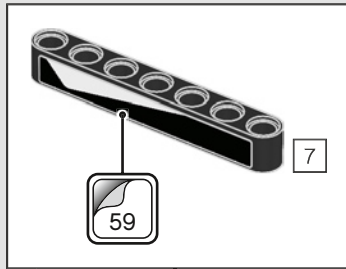

426

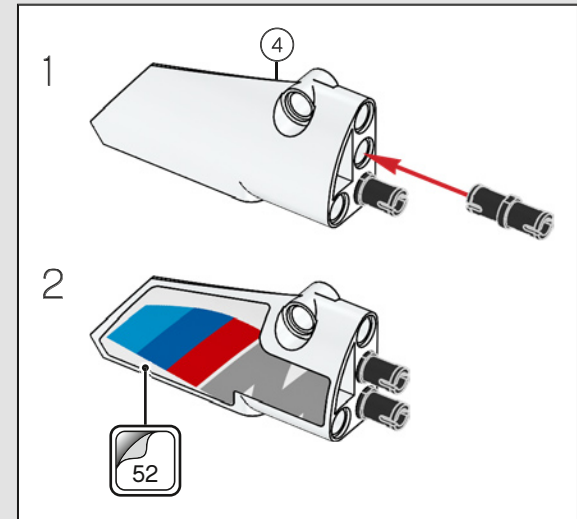

427

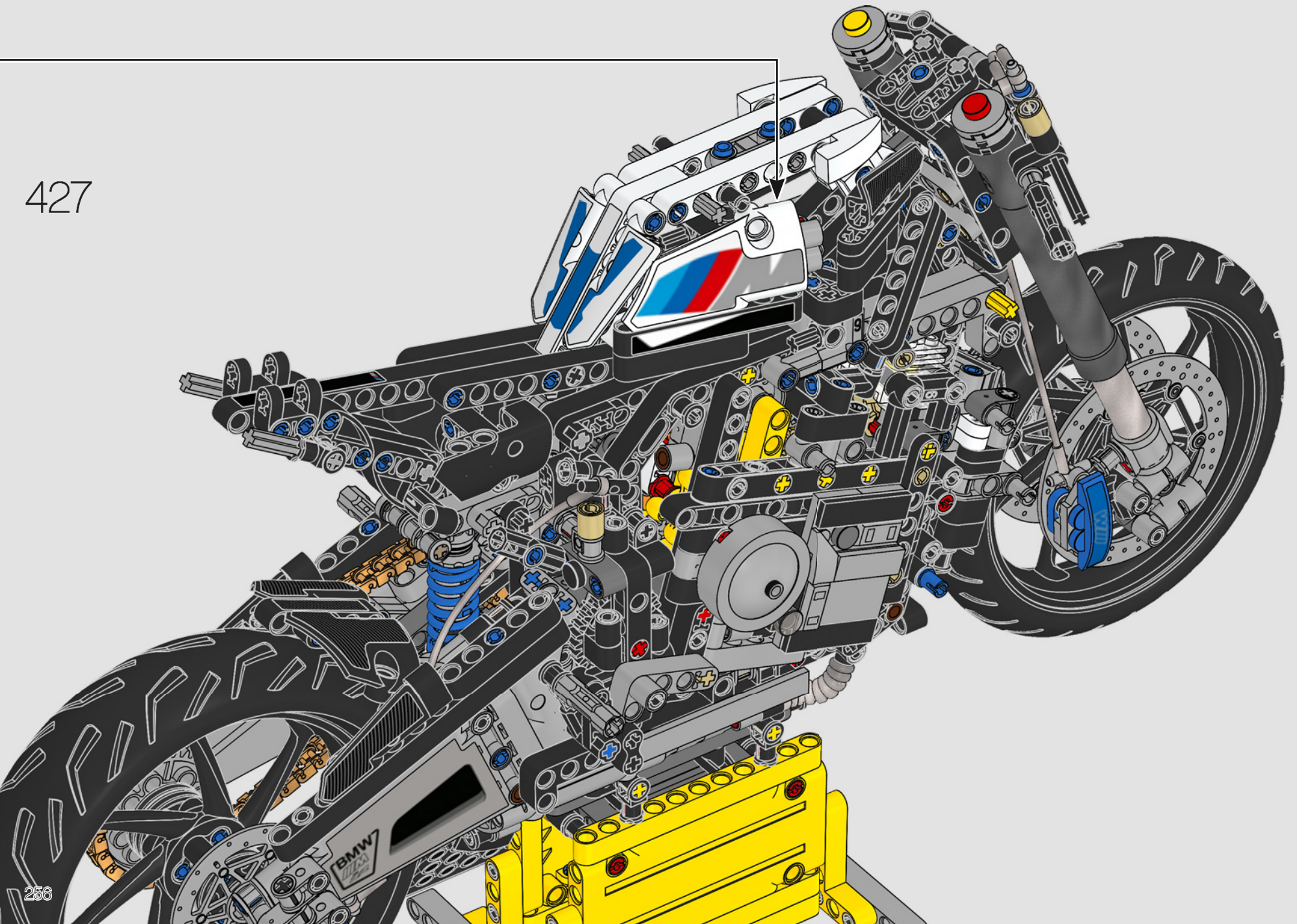

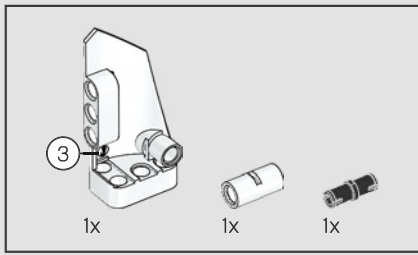

428

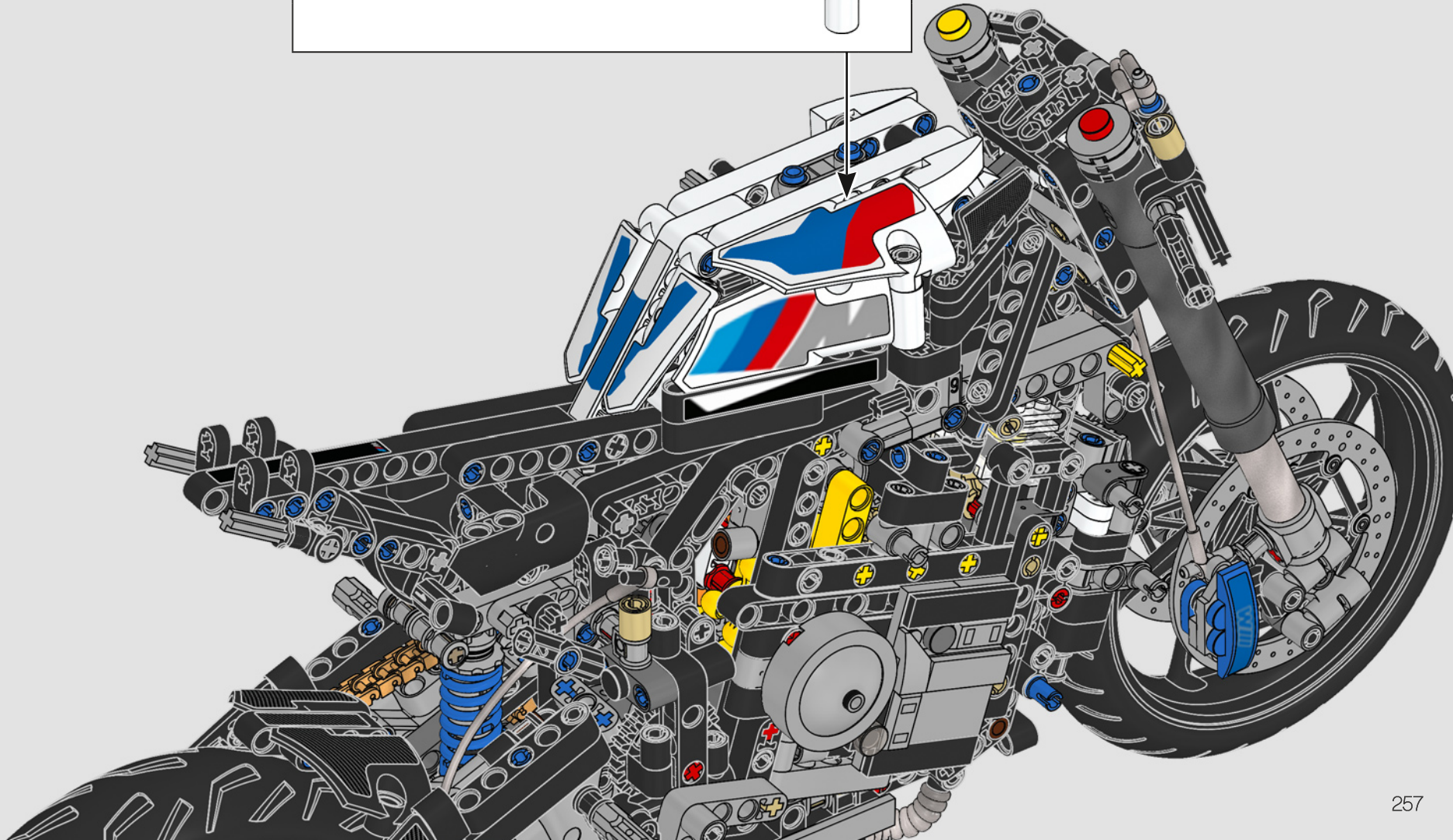
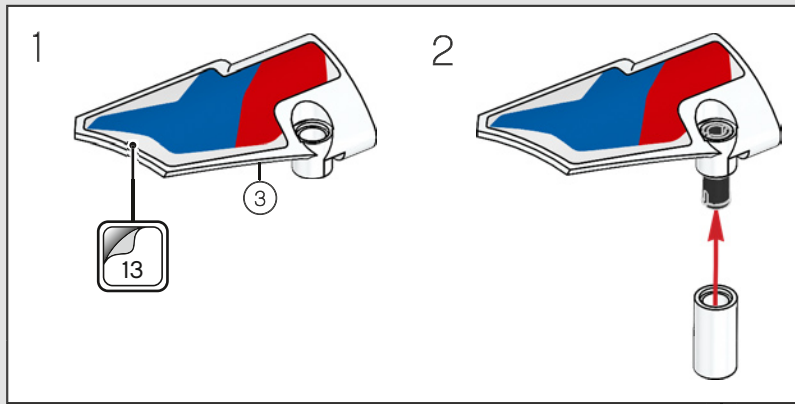

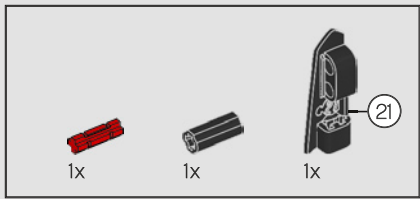

429

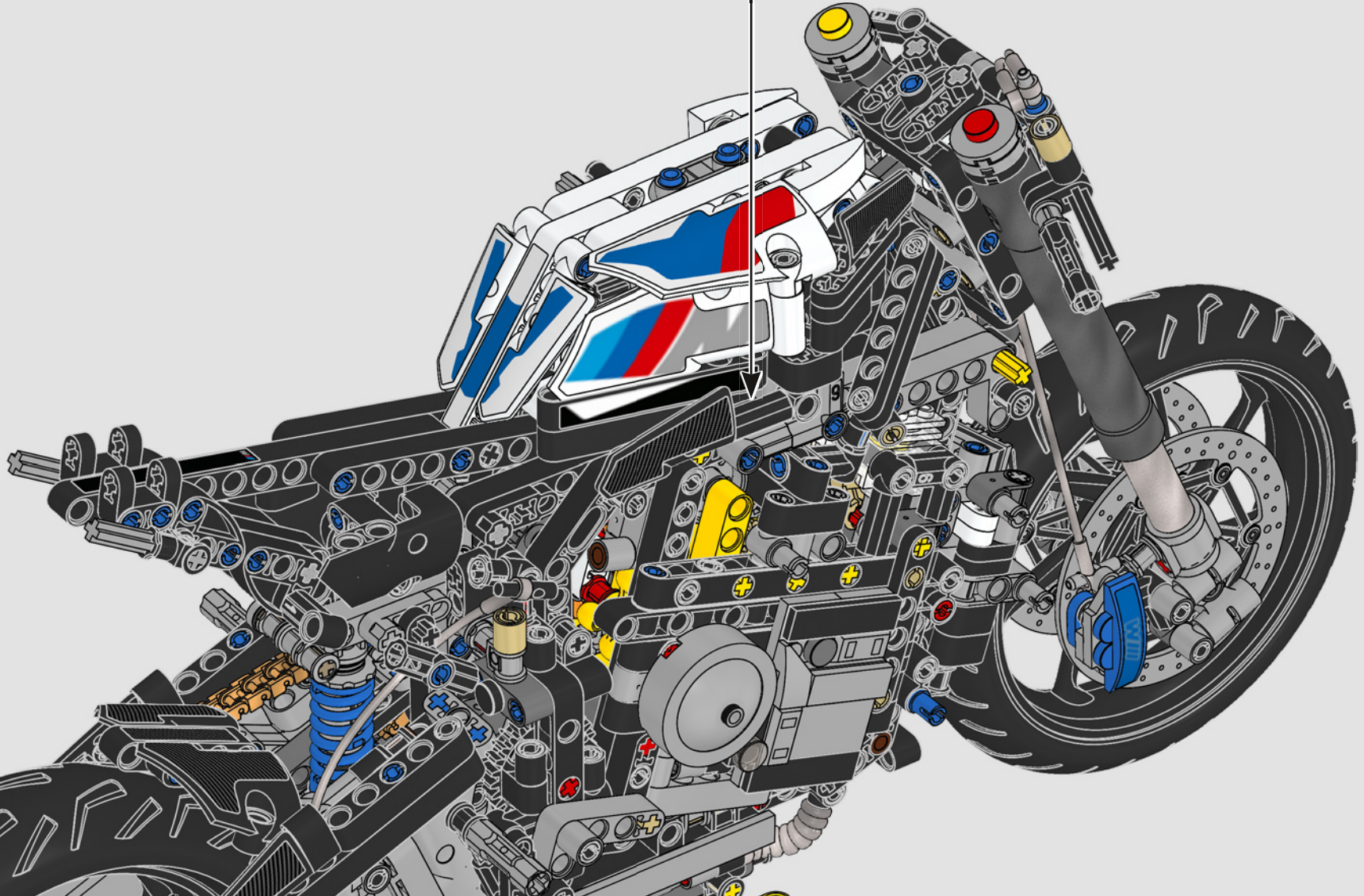
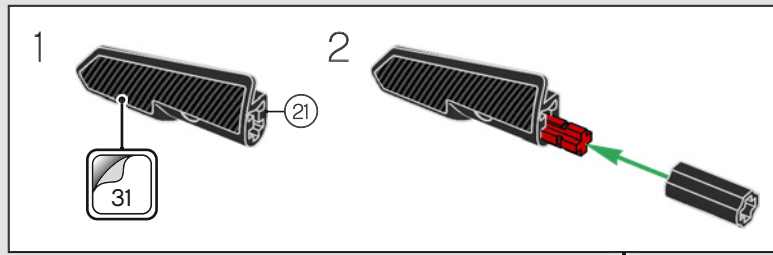

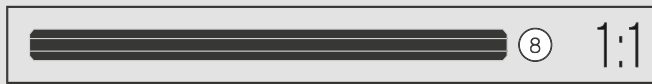
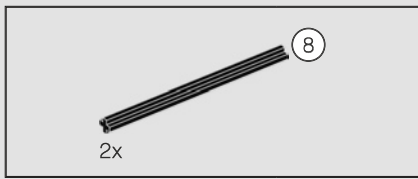

430

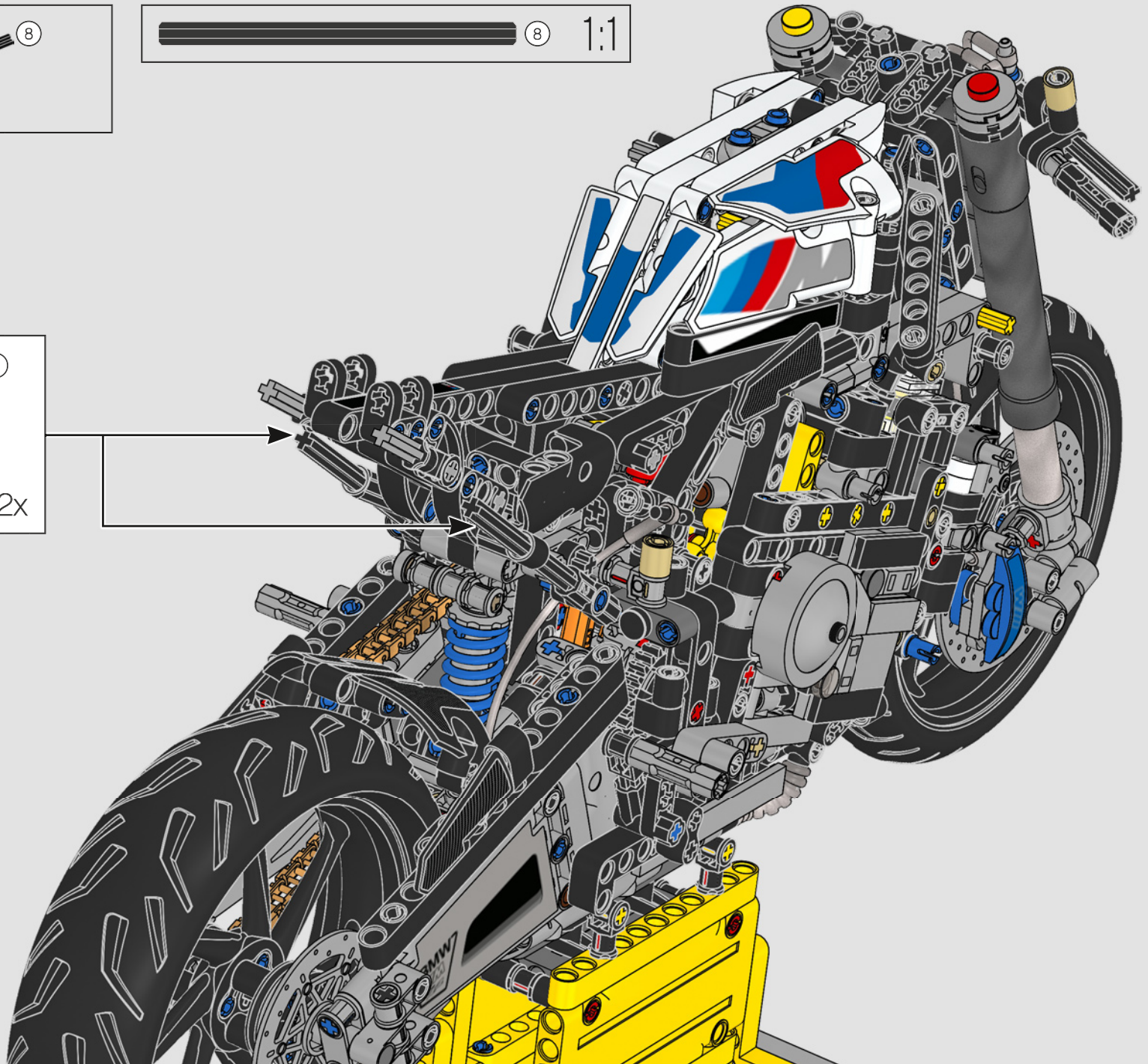
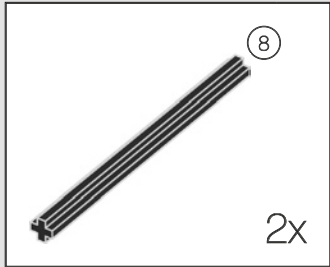

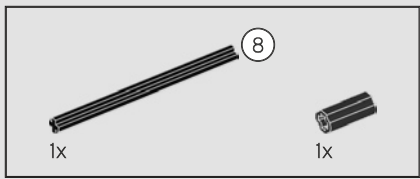

431

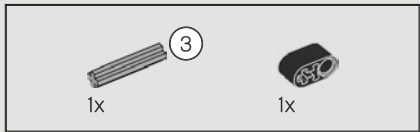
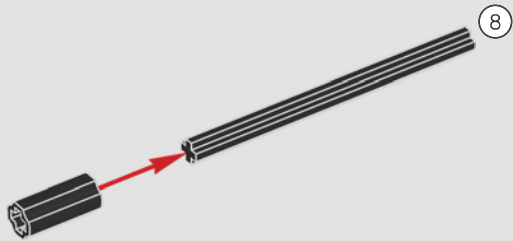

432

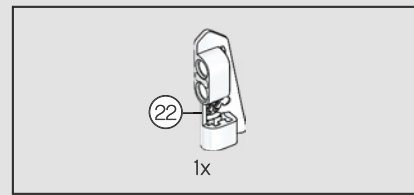
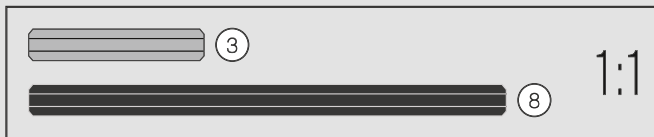
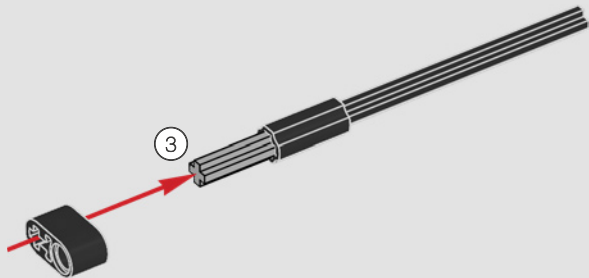

433

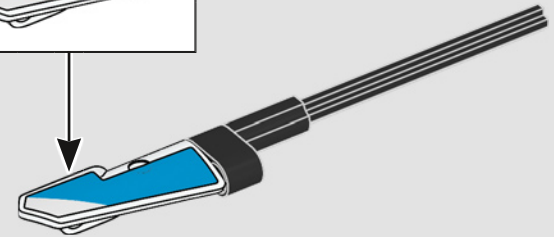

434

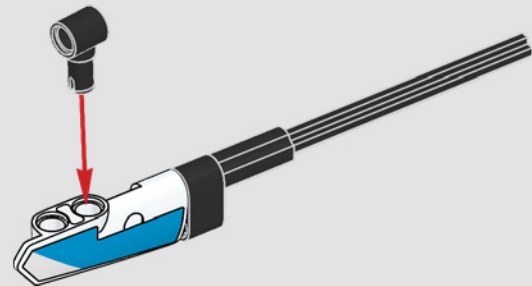

435

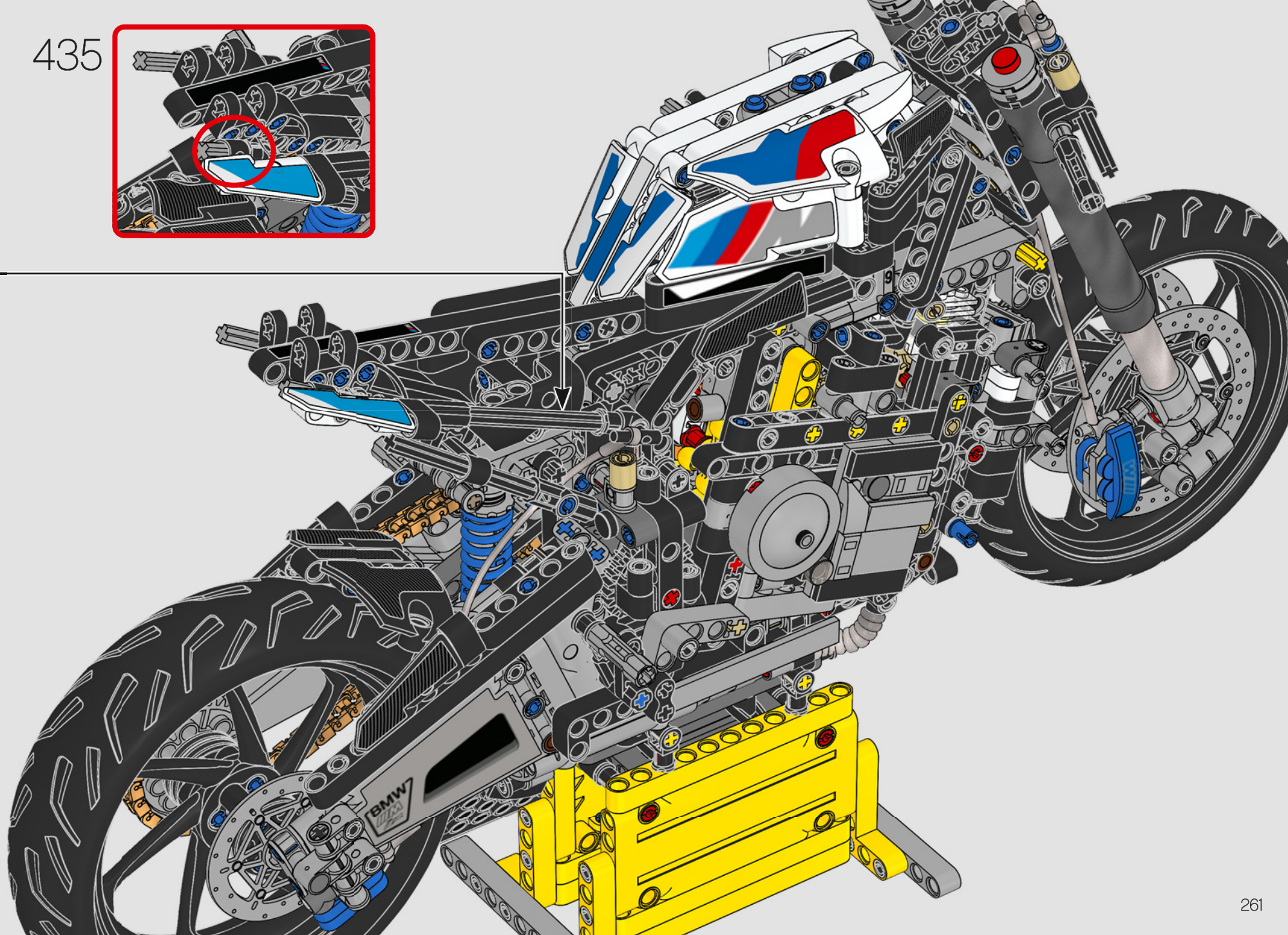
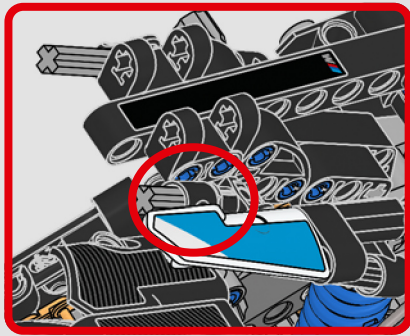

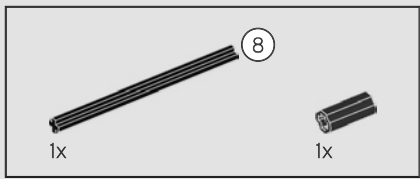

436

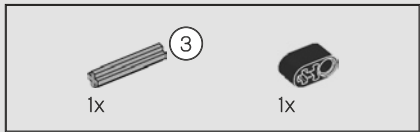
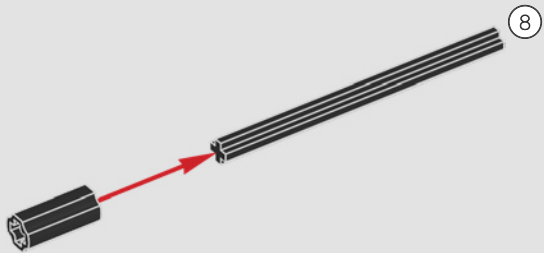

437

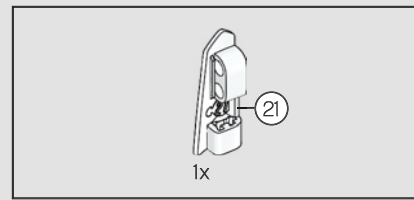
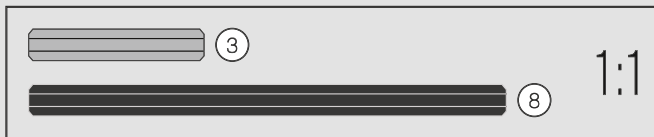
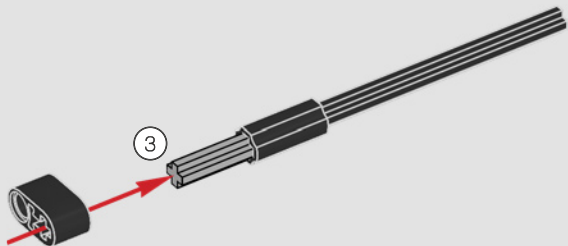

438

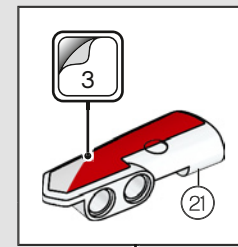
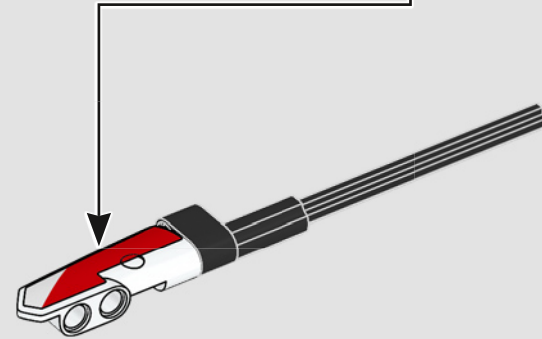

439

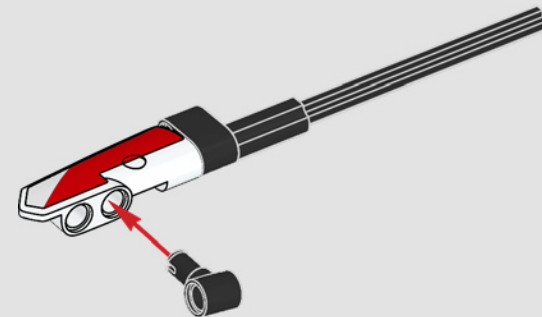

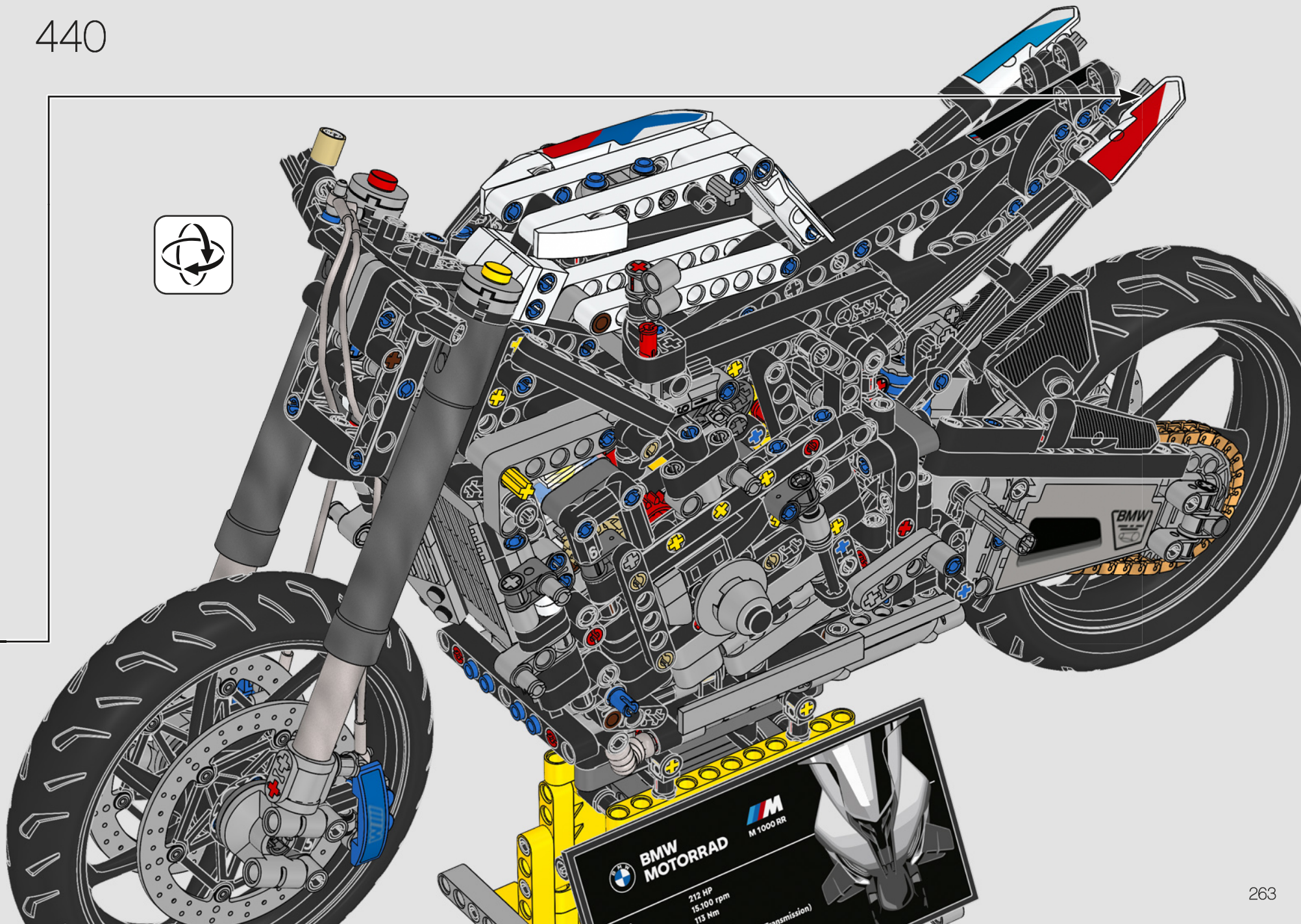

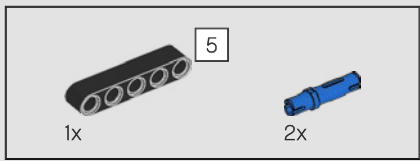

441

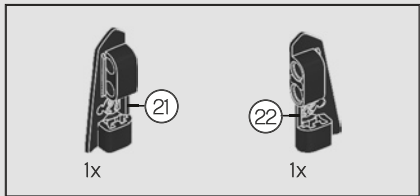
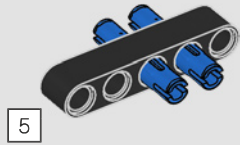

442

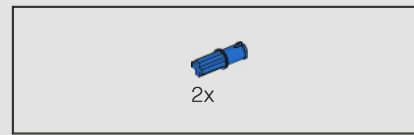
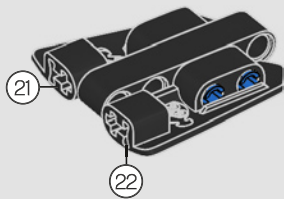

443

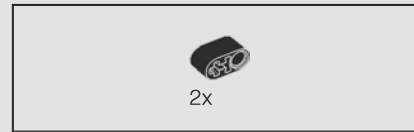
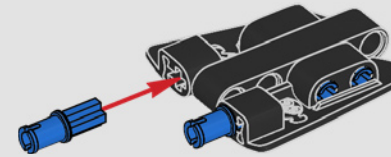

444

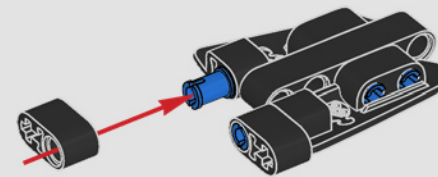

445

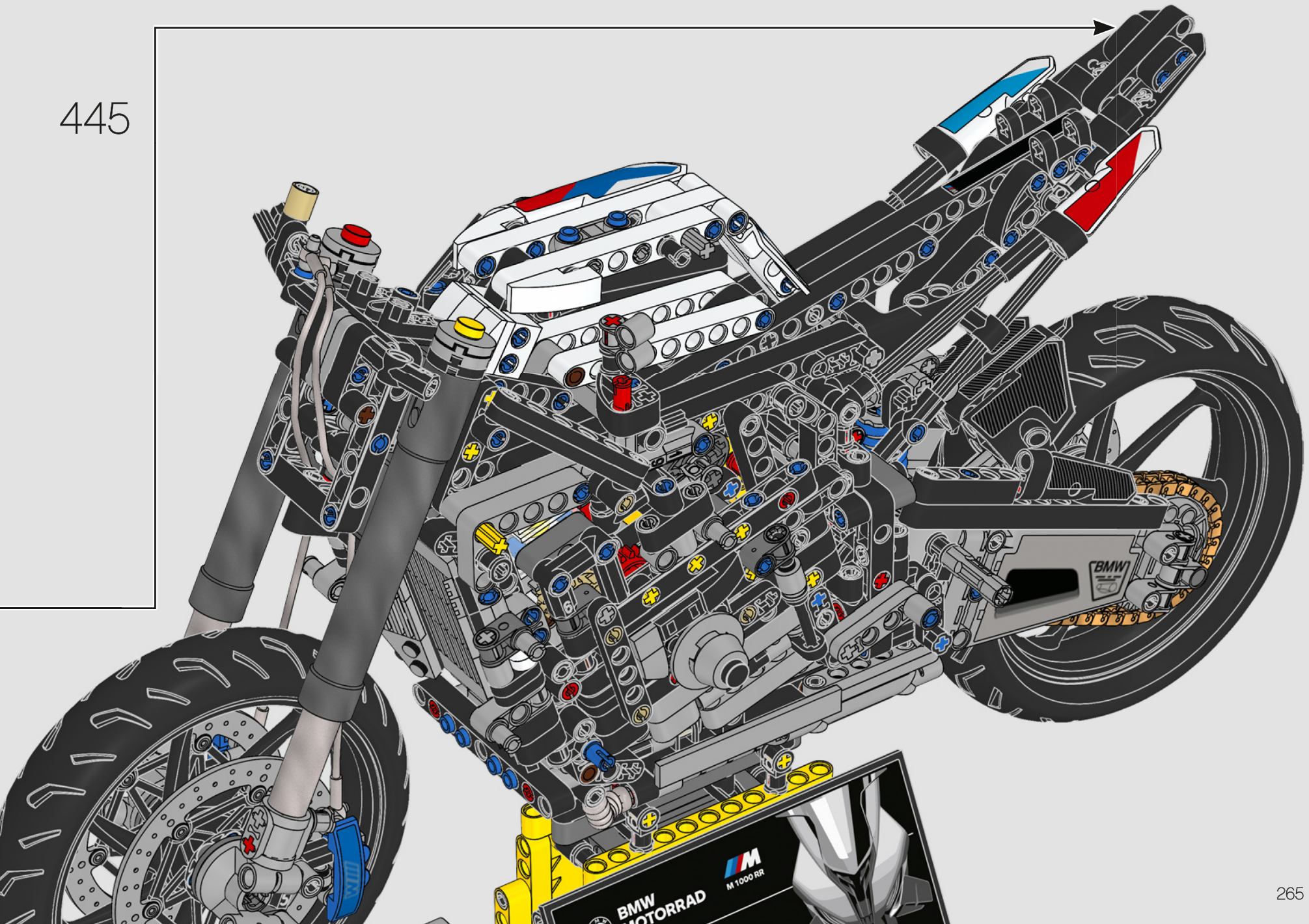

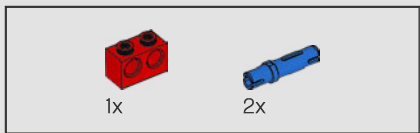

446

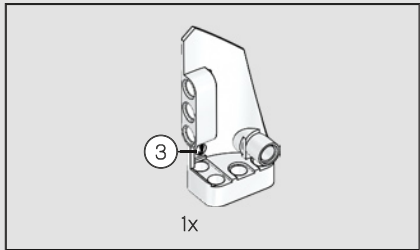
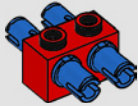

447

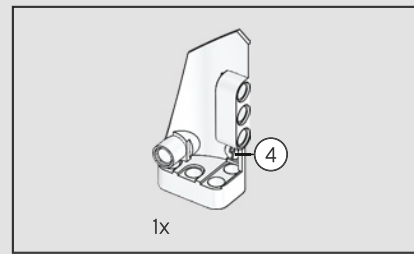
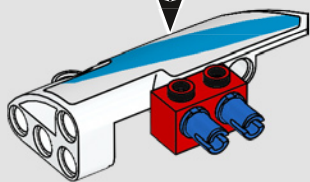
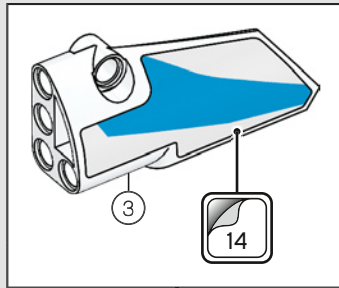

448

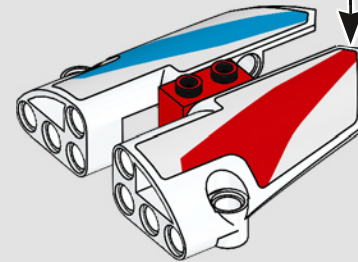
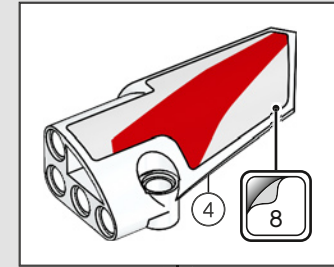

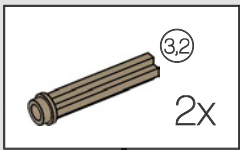
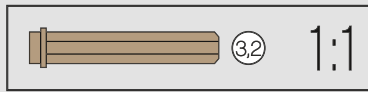
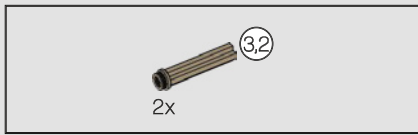

449

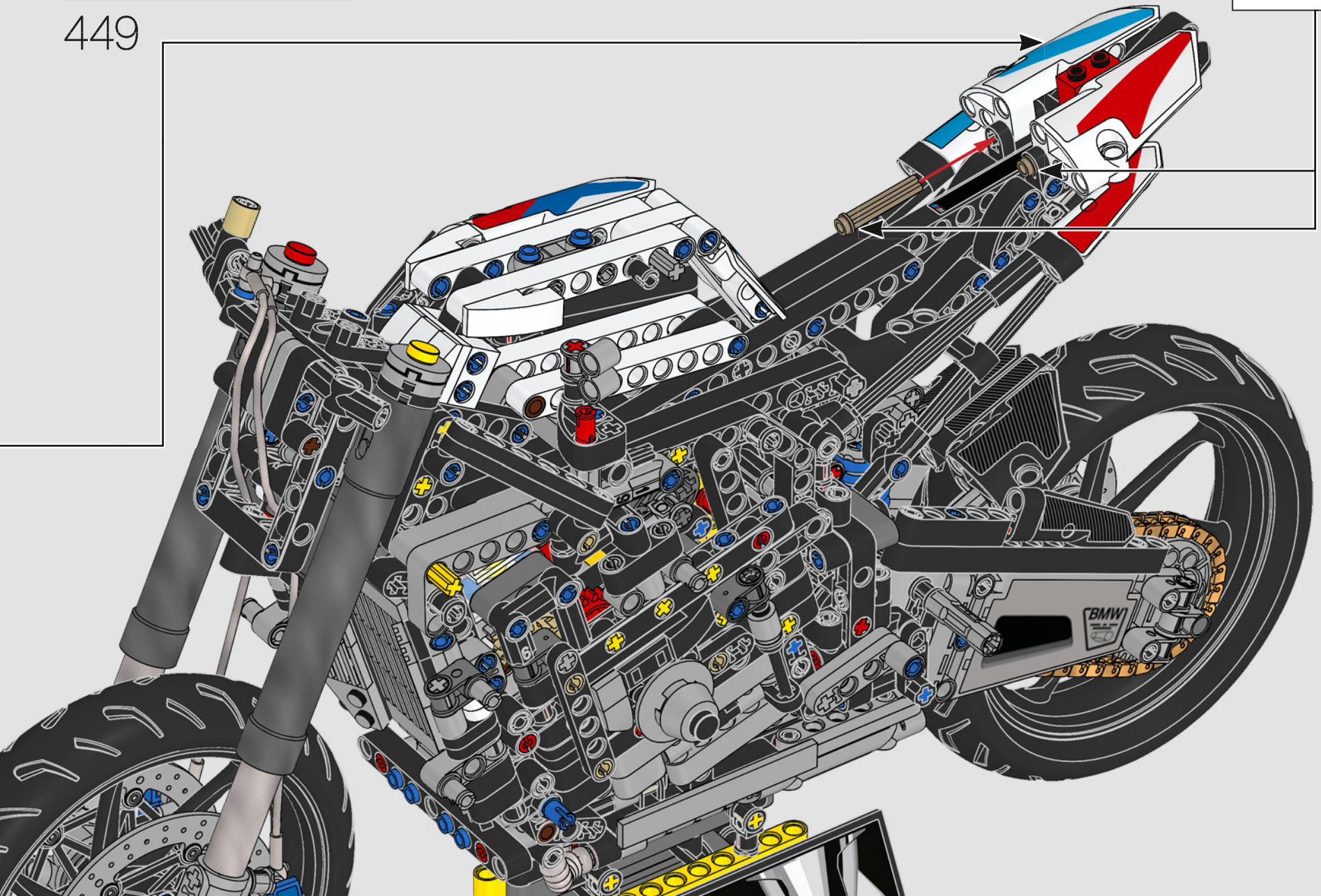

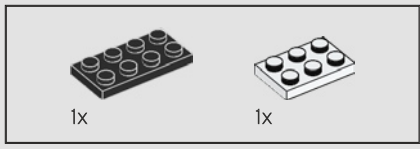

450

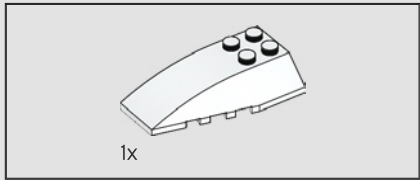
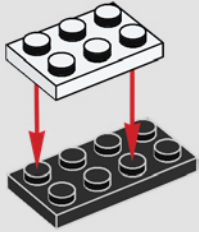

451

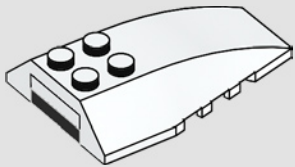

452

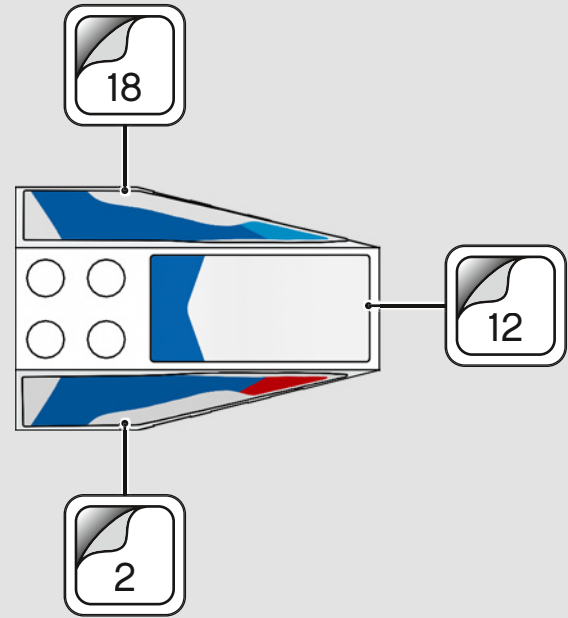

453

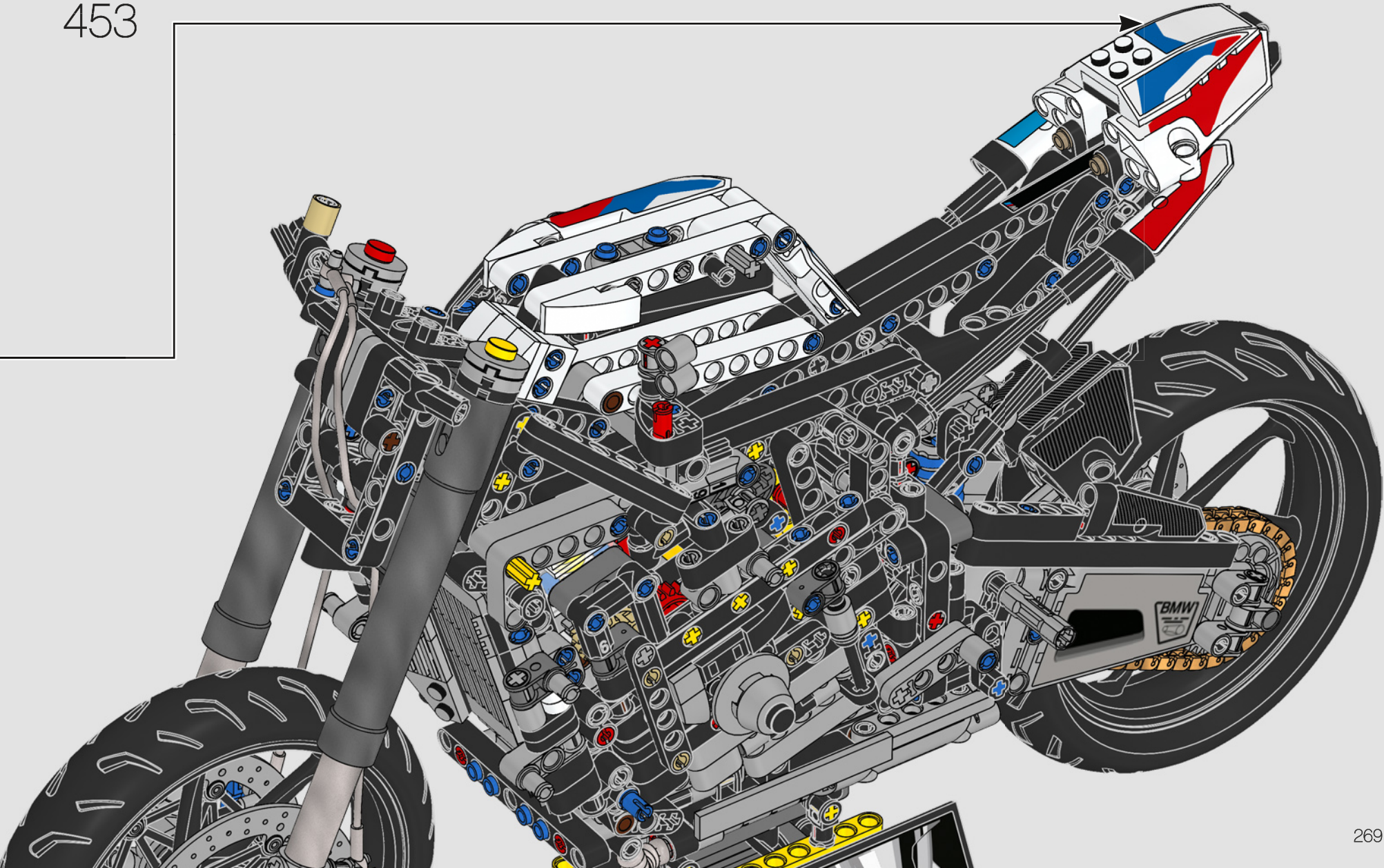



454

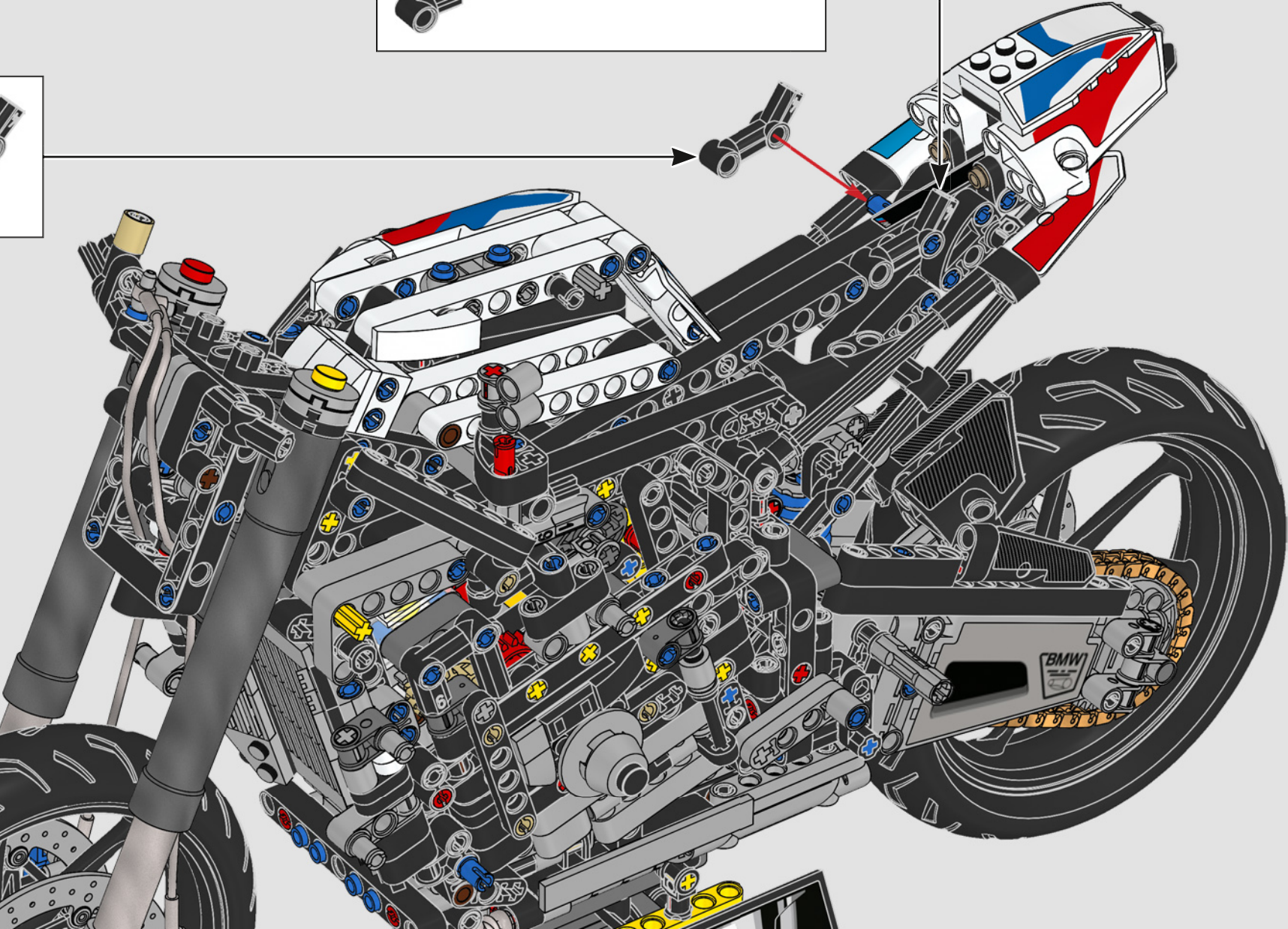
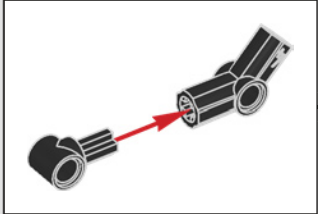
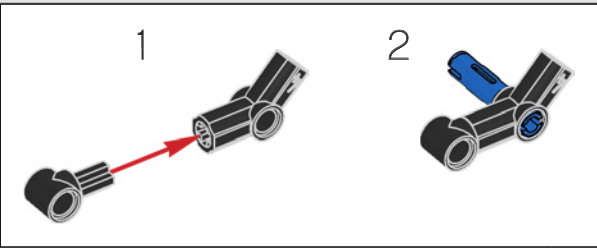

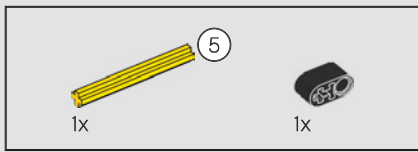

455



456

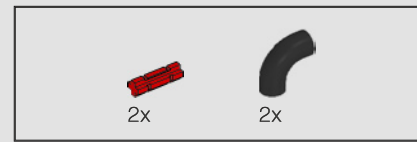
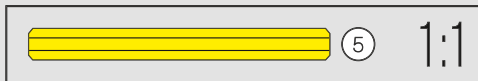
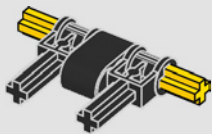

457

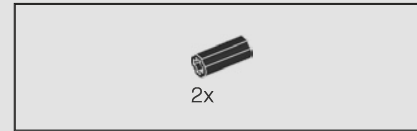
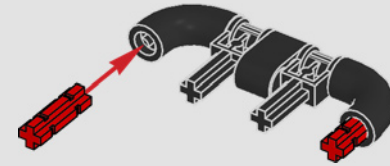

458

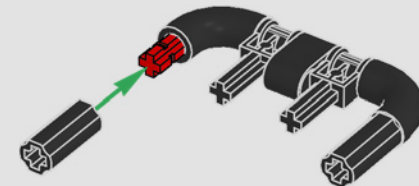

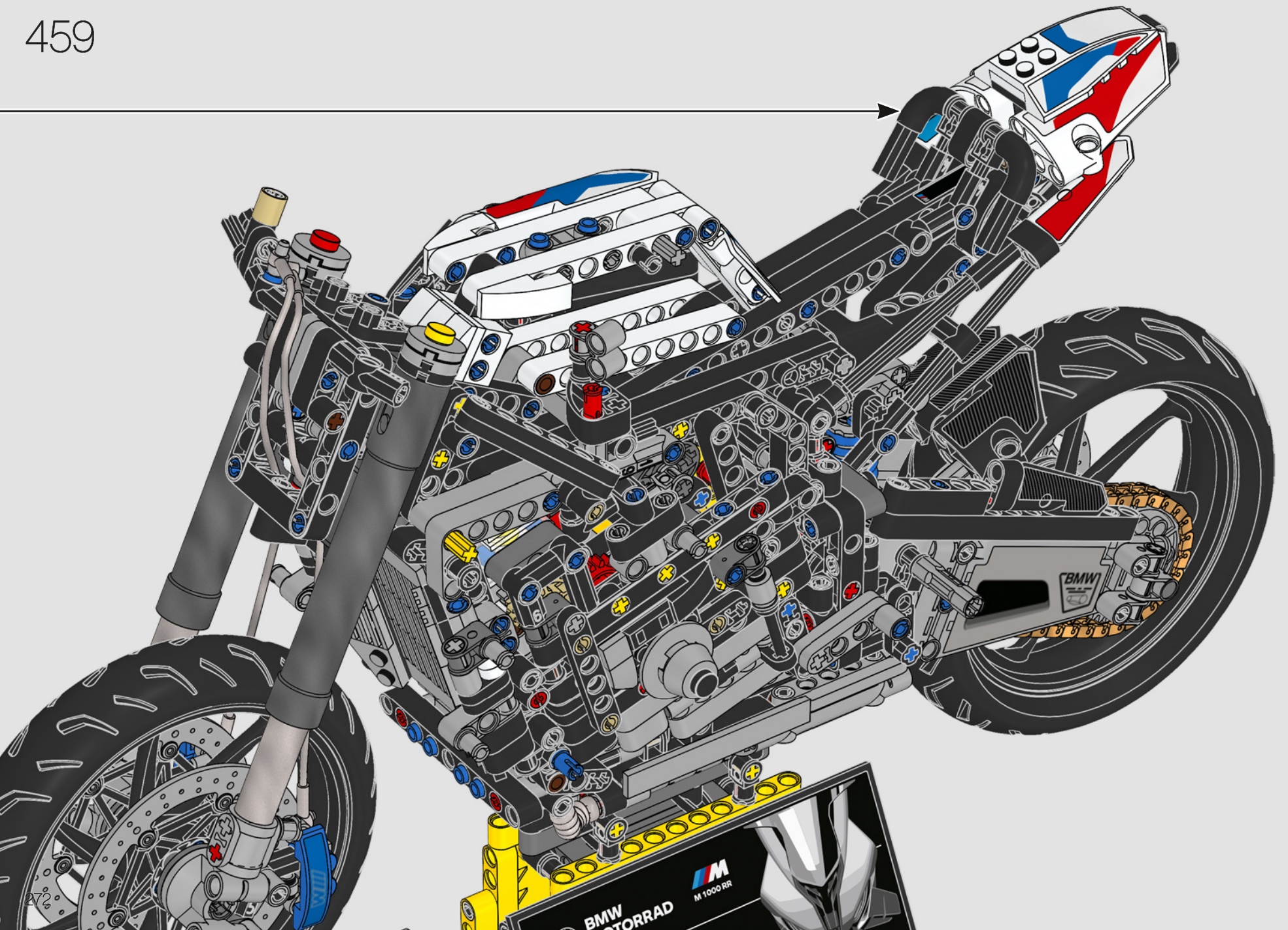

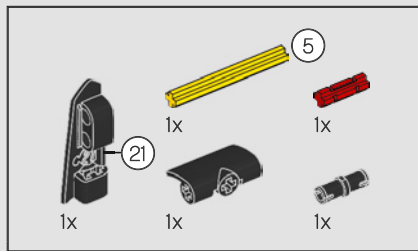

460

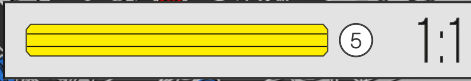
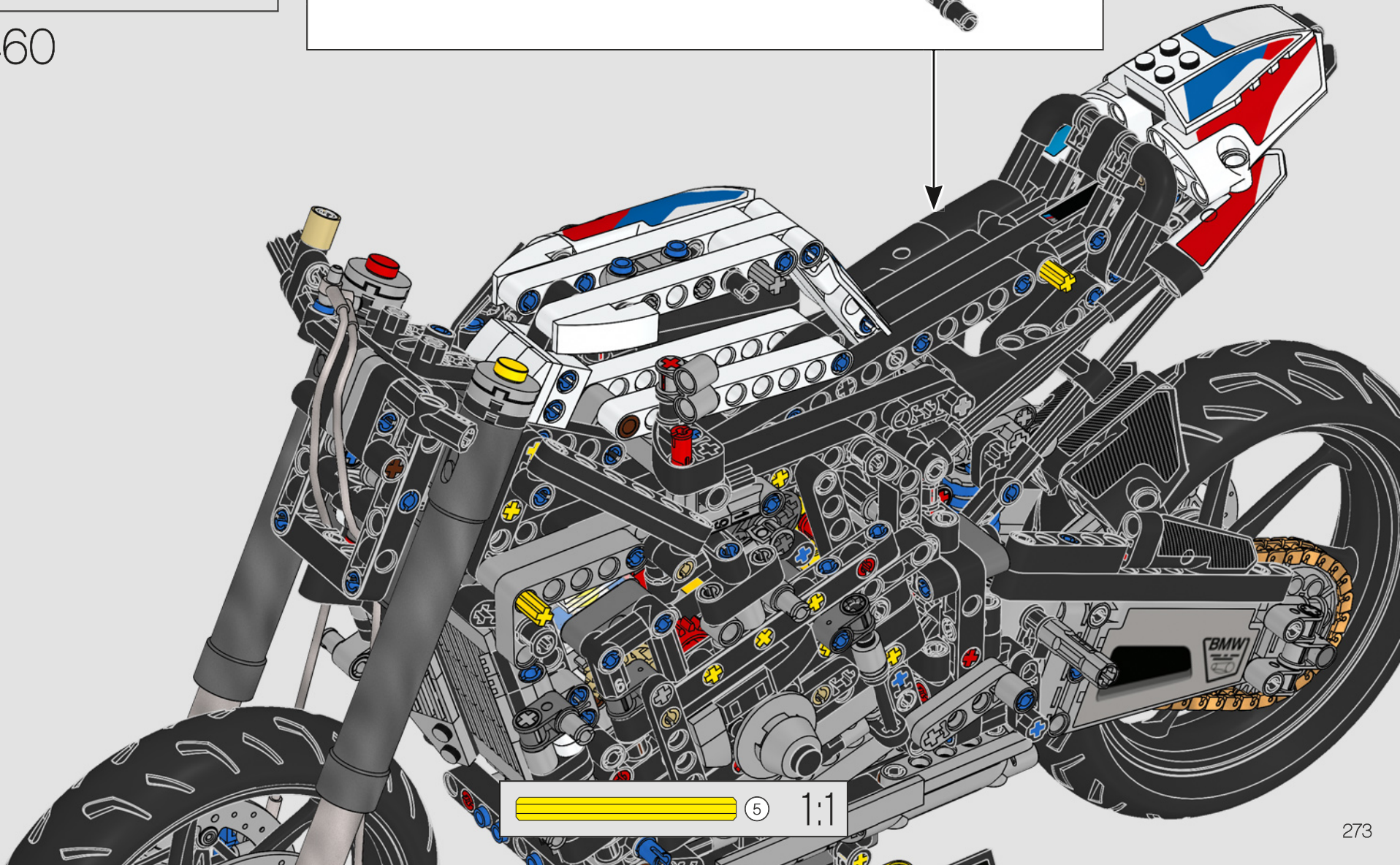
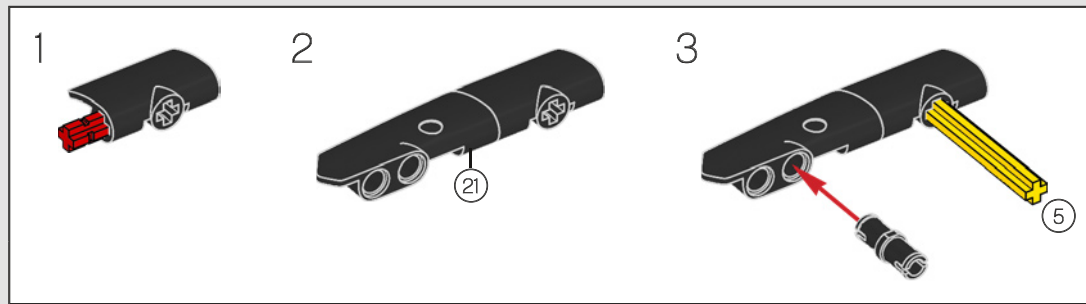

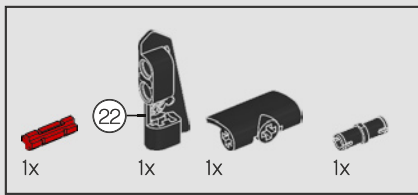

461

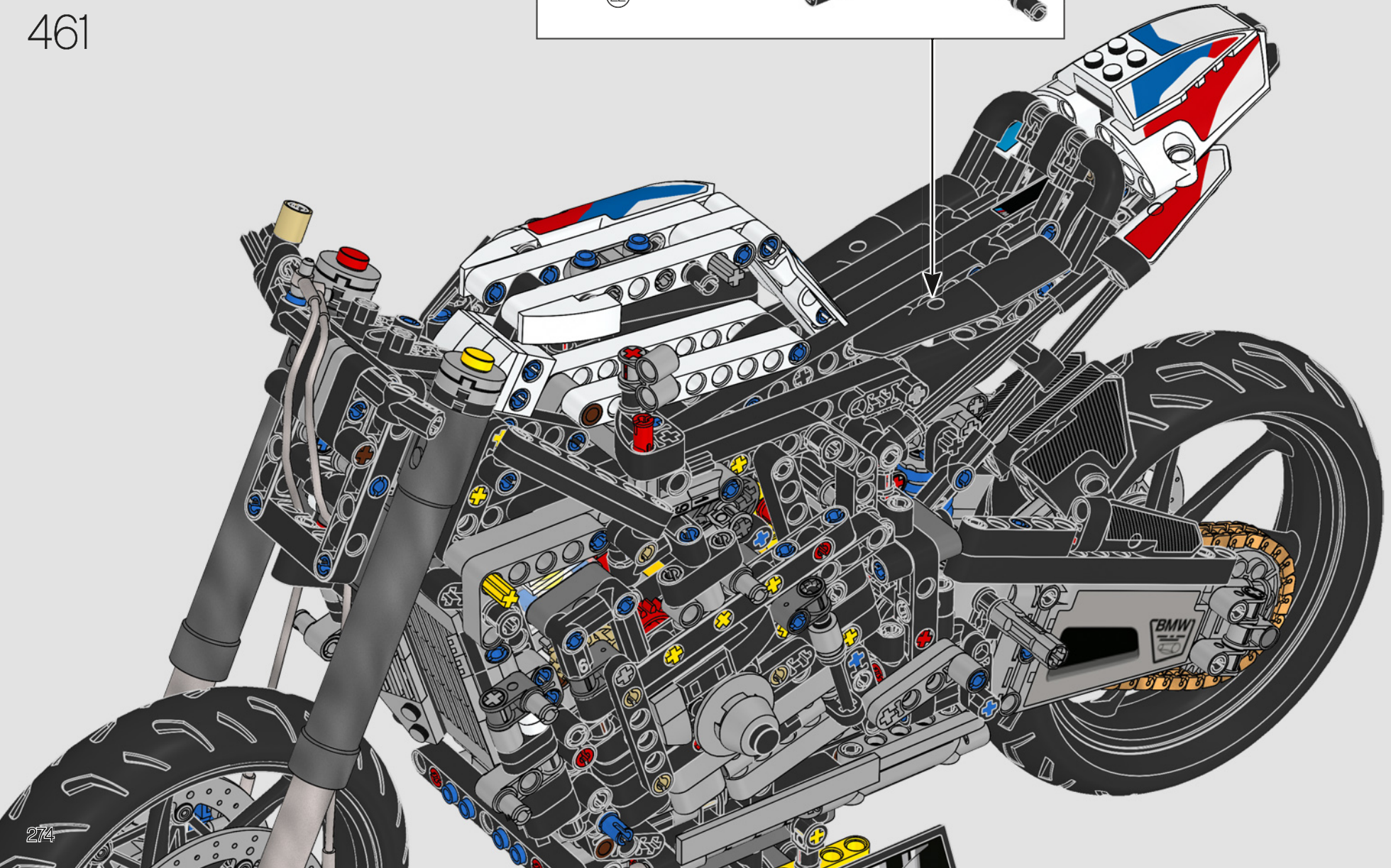
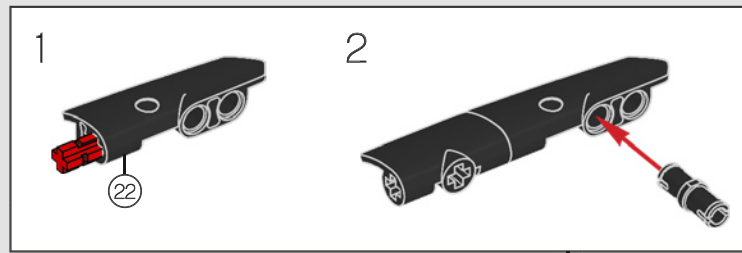

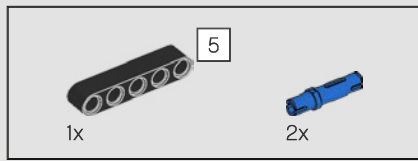

462

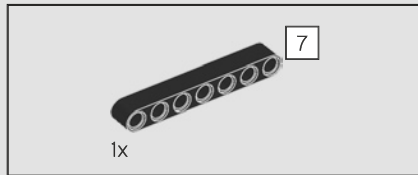
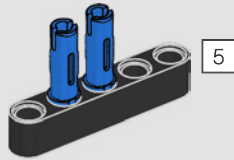

463

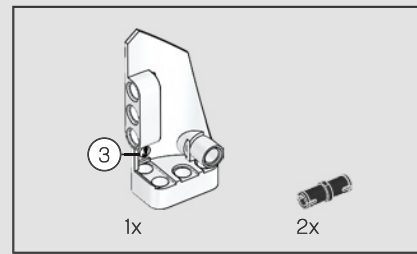
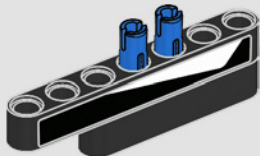
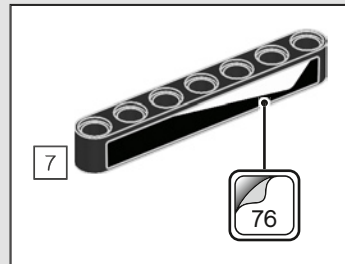

464

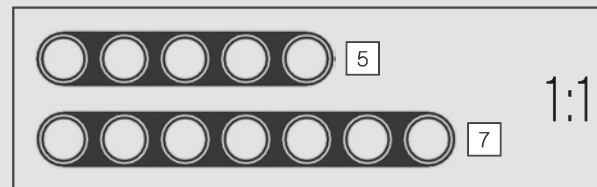
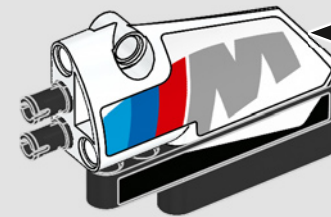
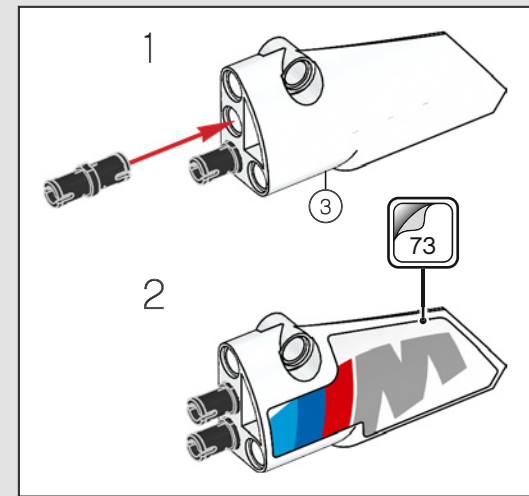

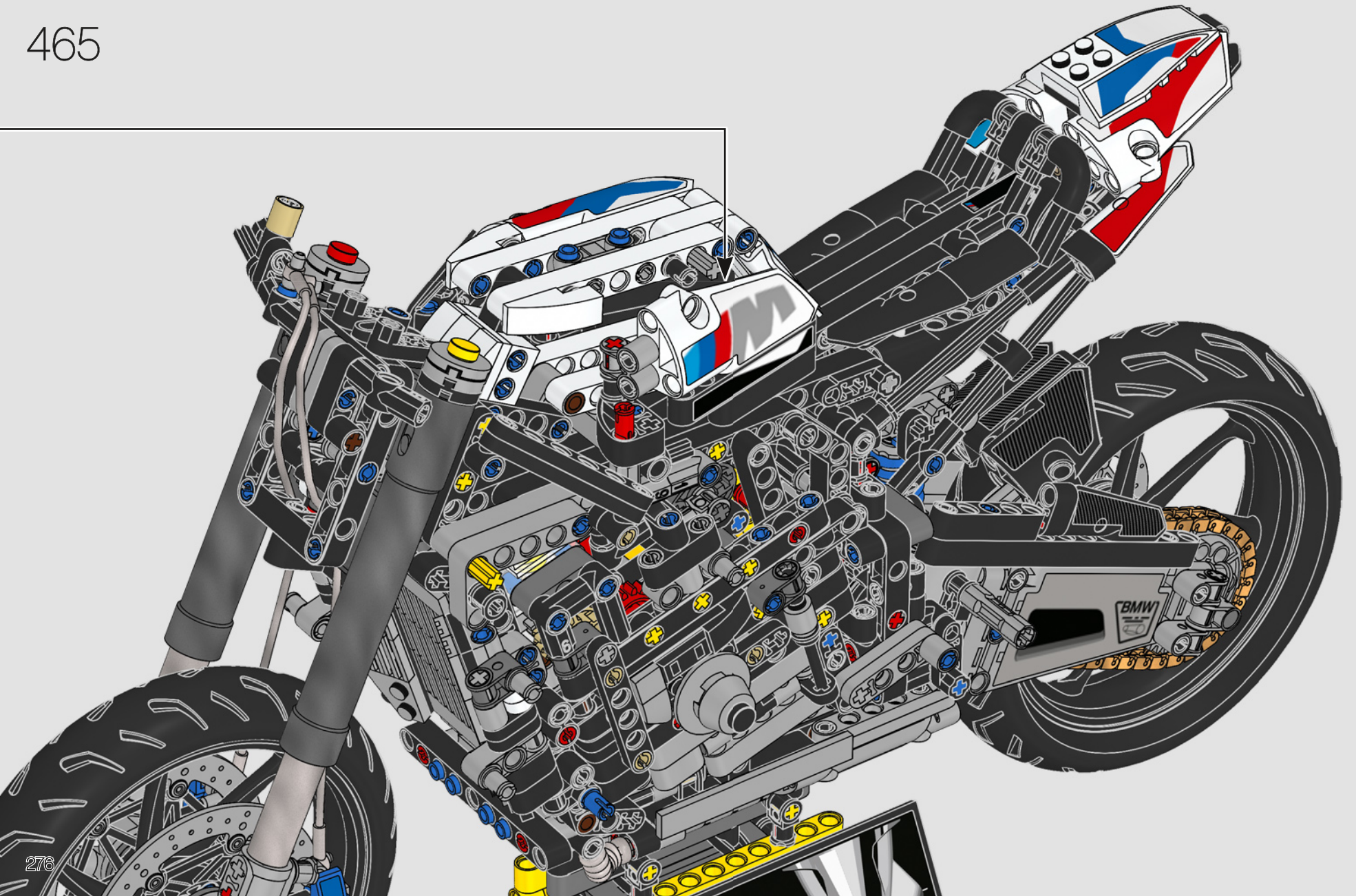



466

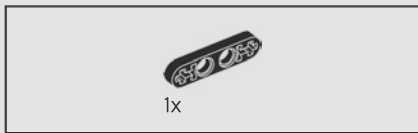
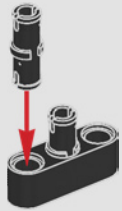

467

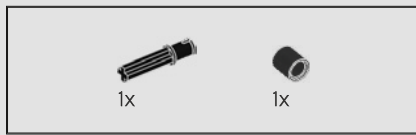
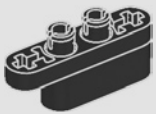

468

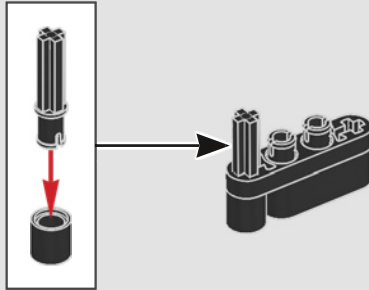

469

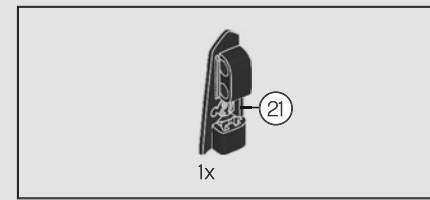
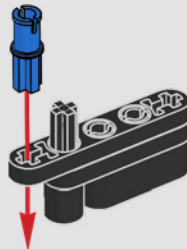

470

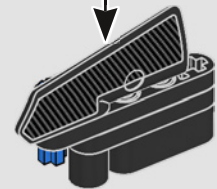
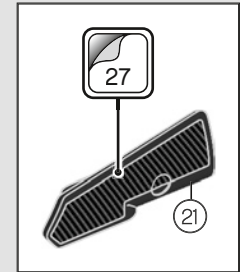

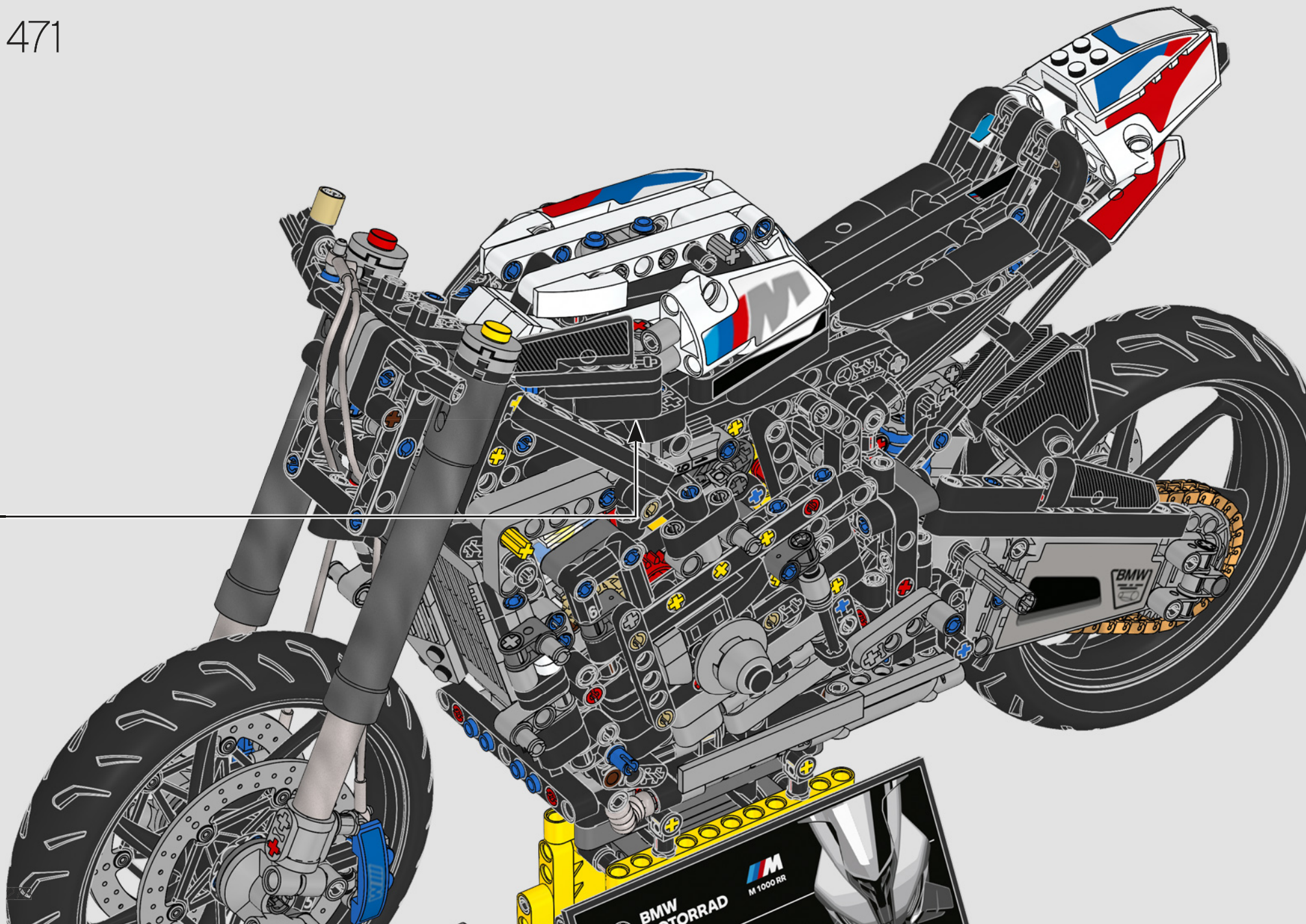

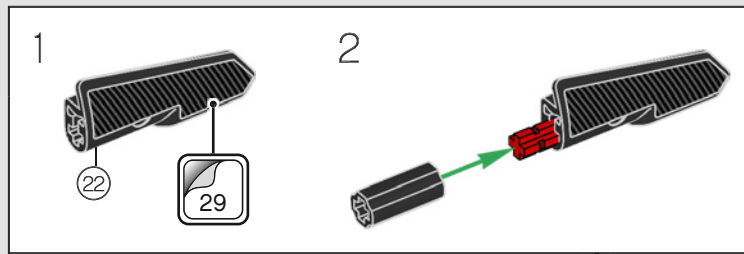
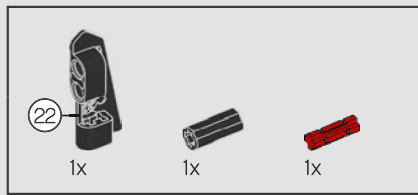

472

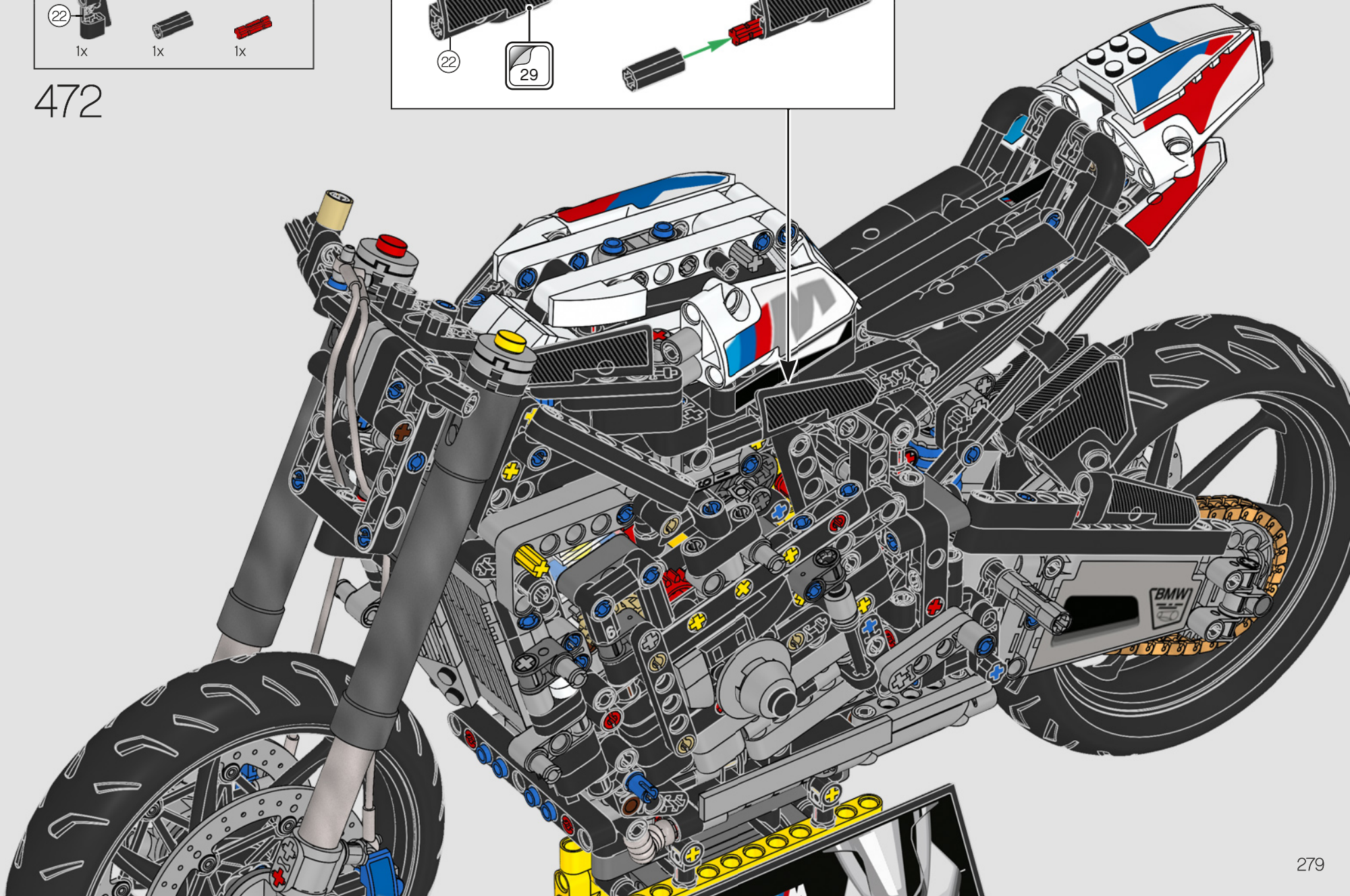

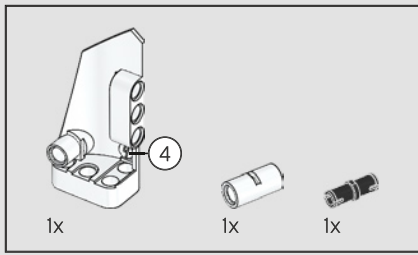

473

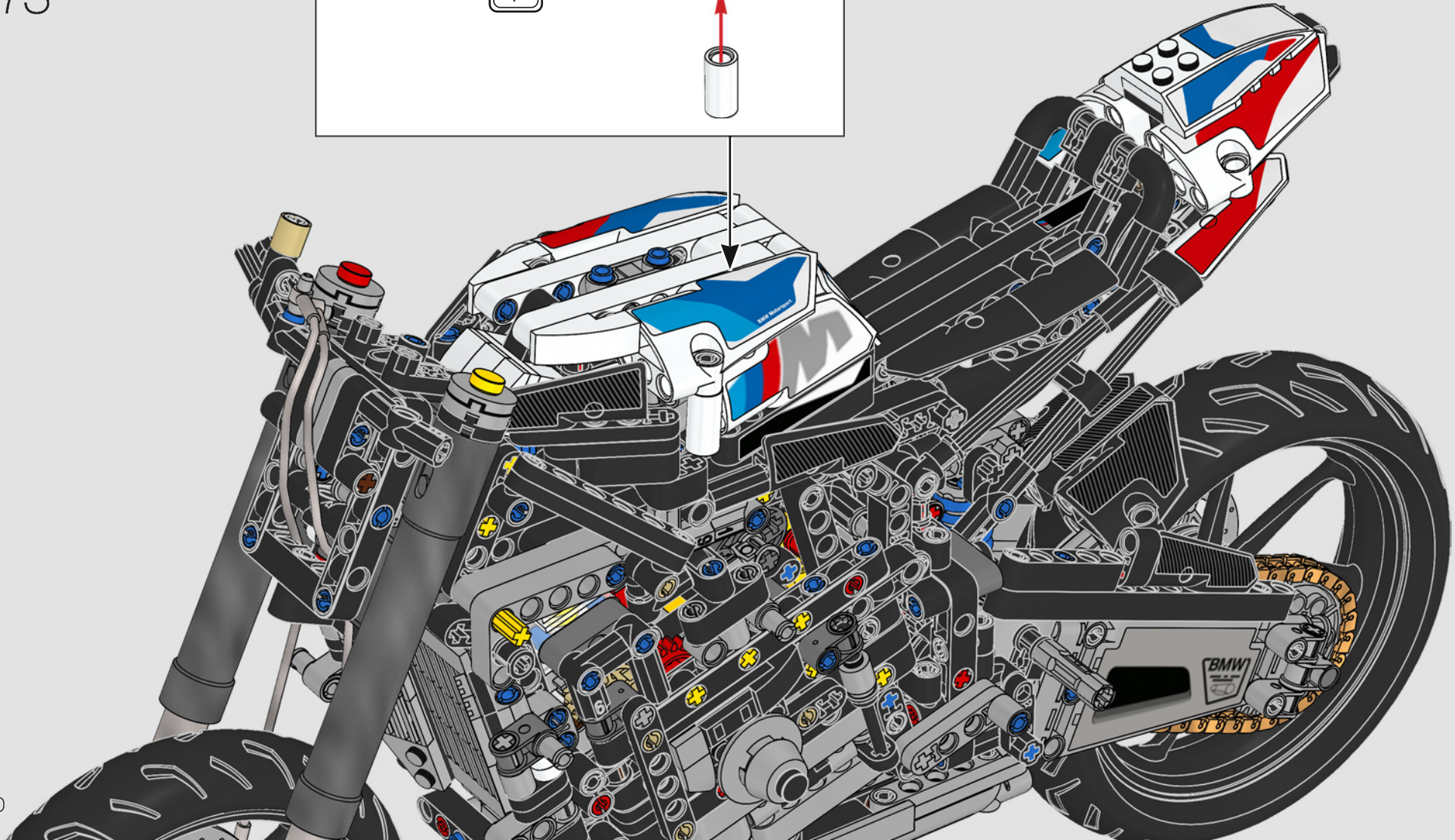
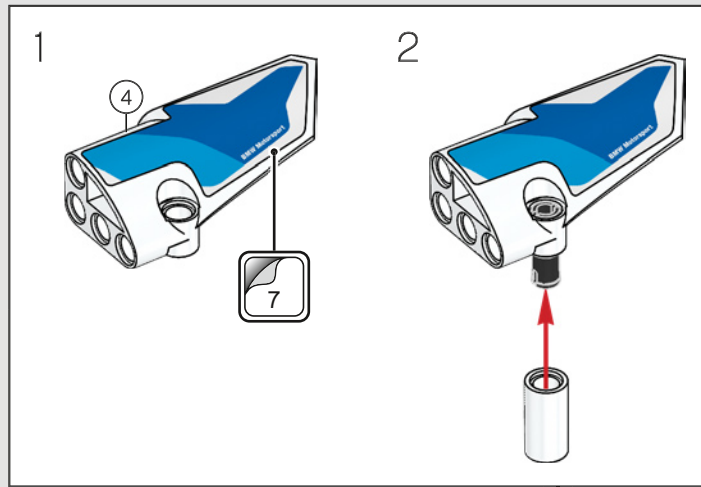

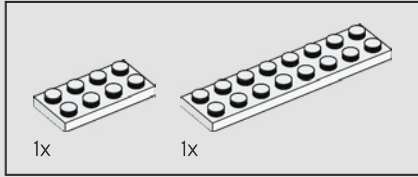
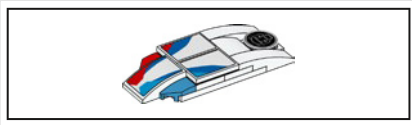

474

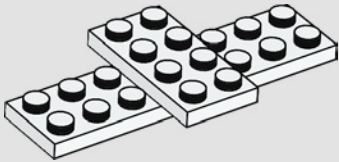

475

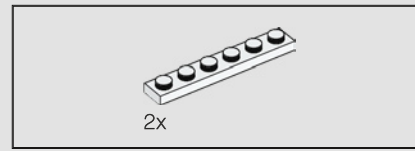
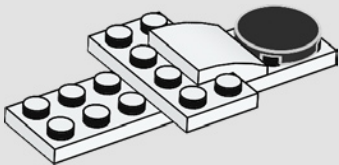

476

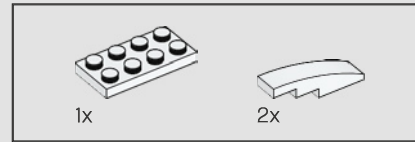
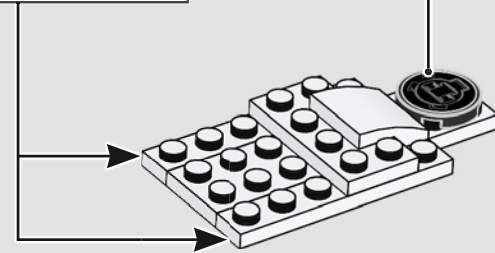
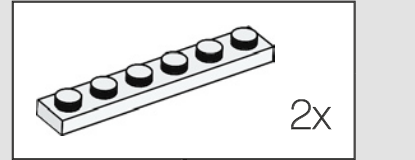

477

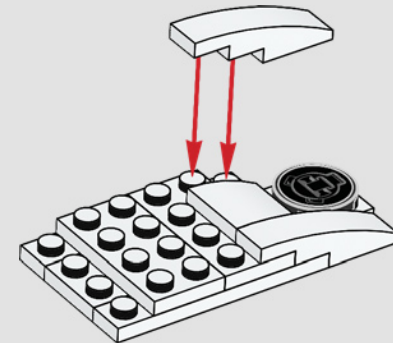

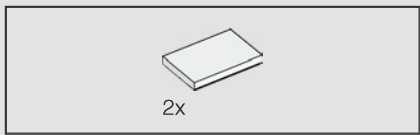

478

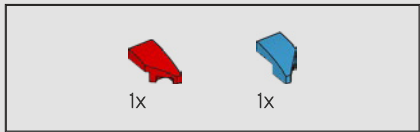
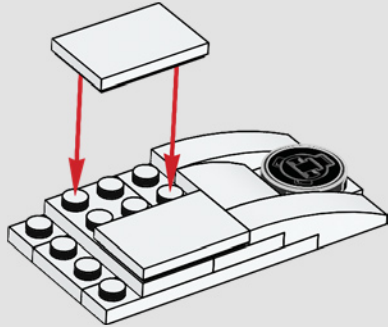

479

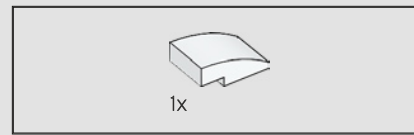
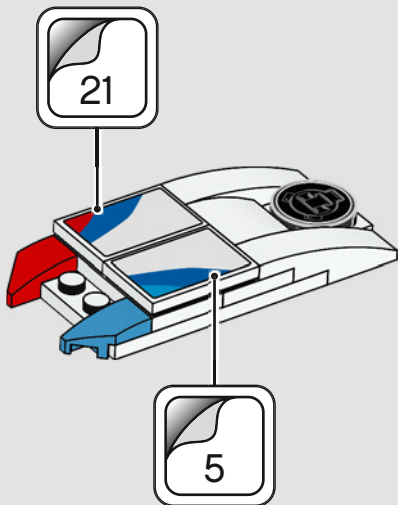

480

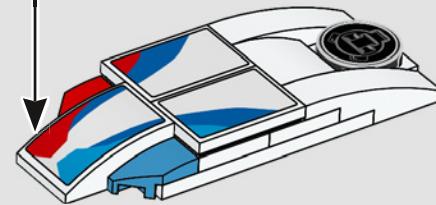
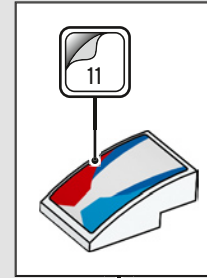

481

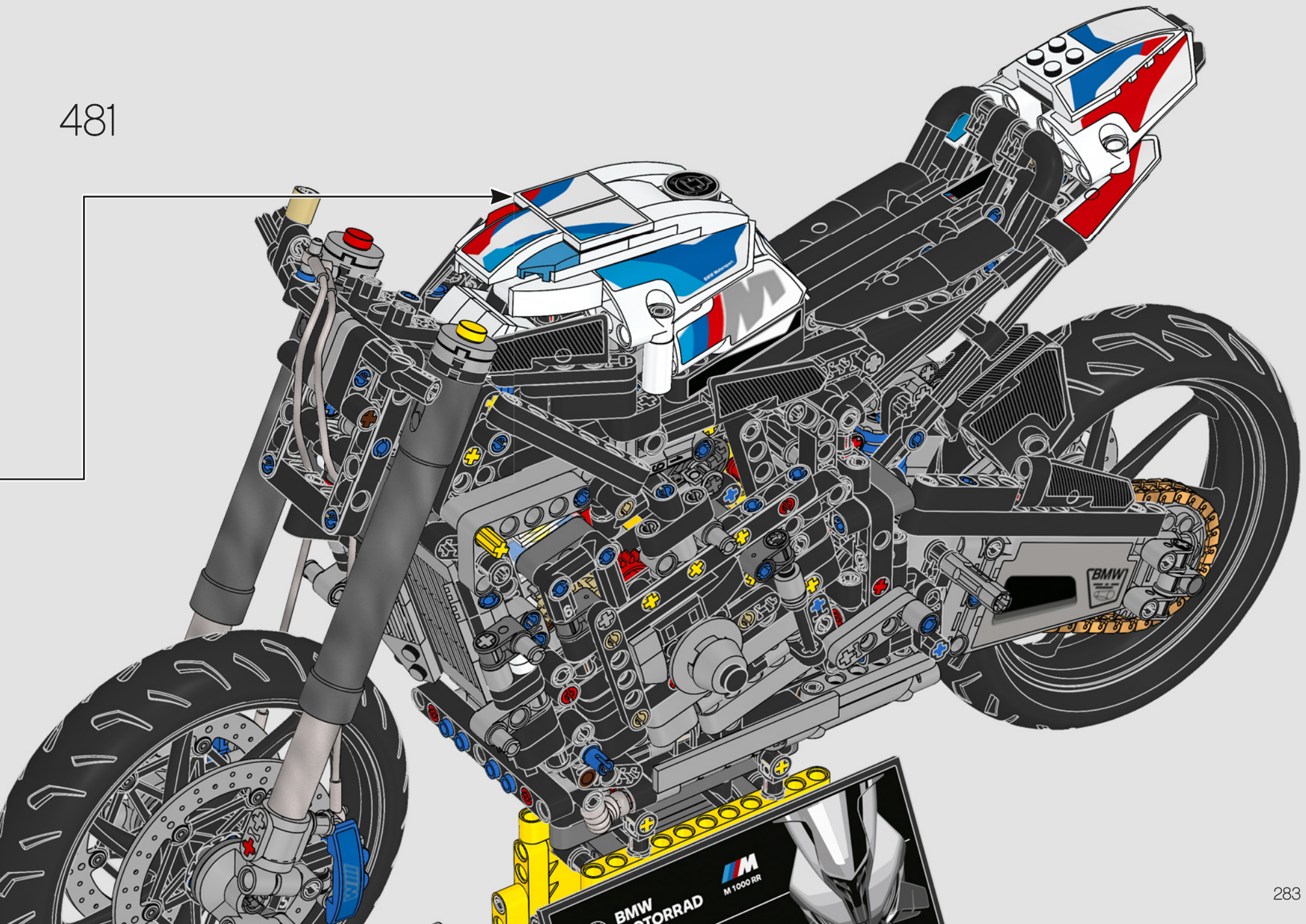

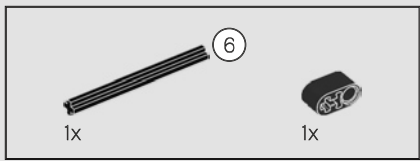

482

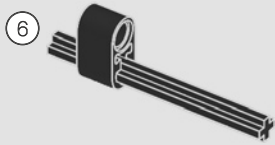

483

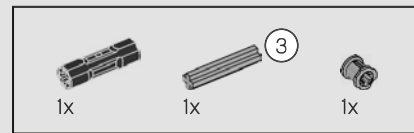
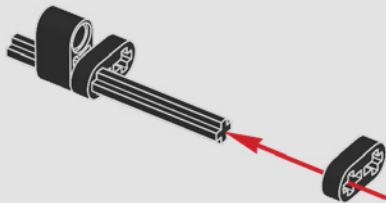

484

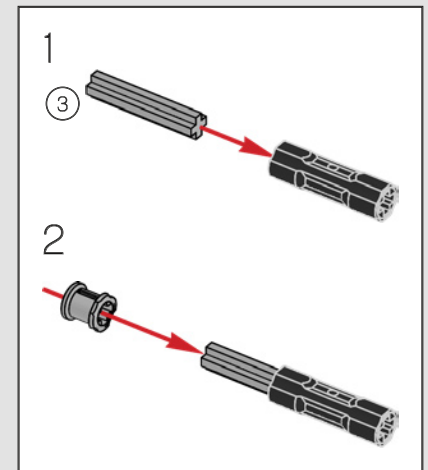

1

2

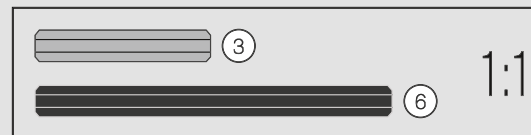
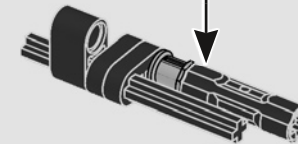

485

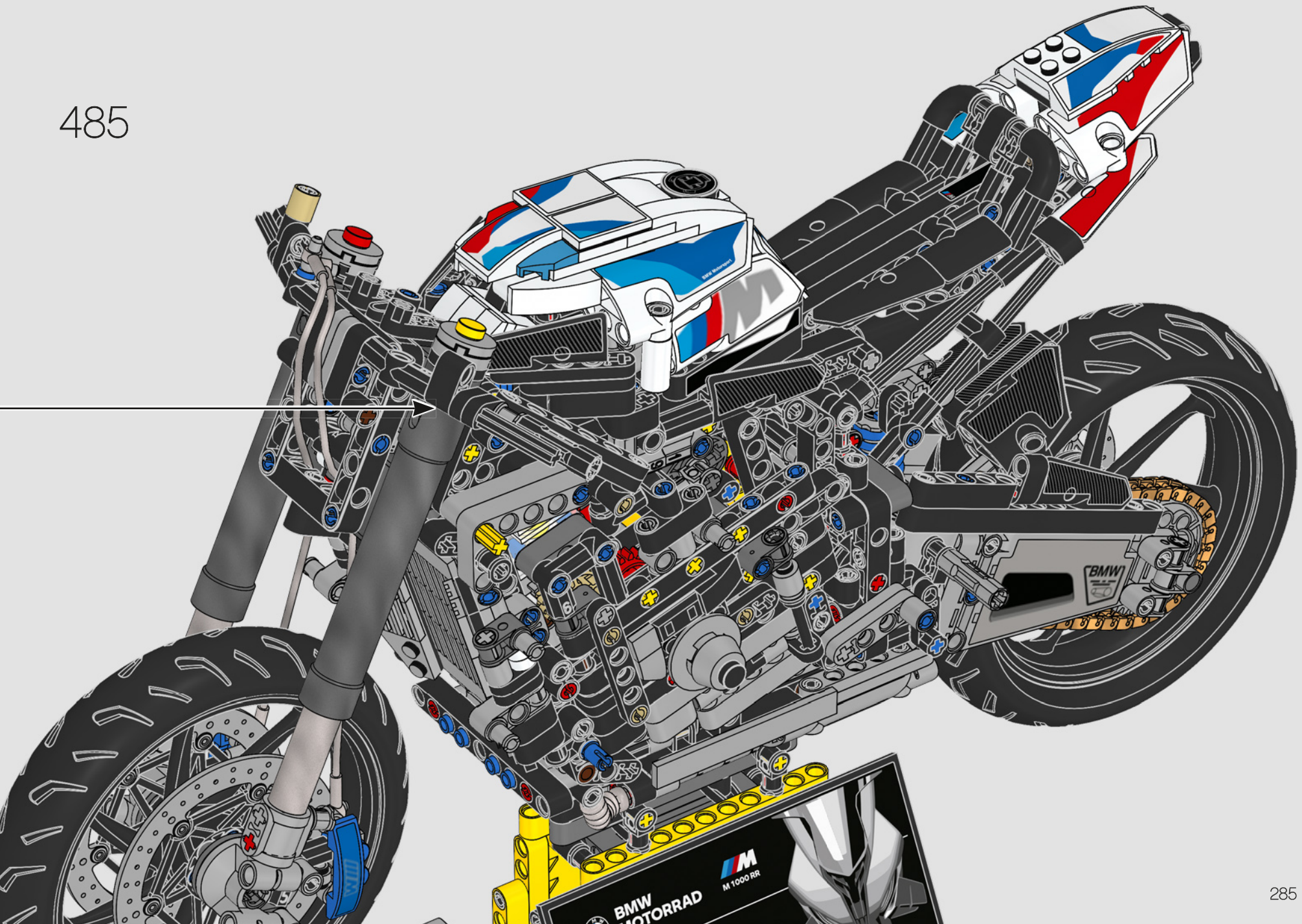

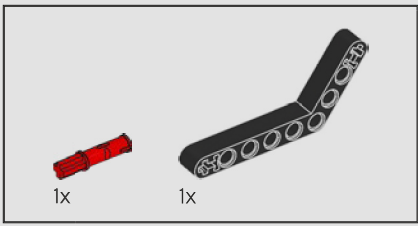

486

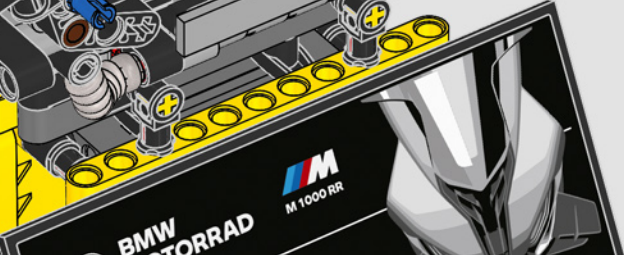
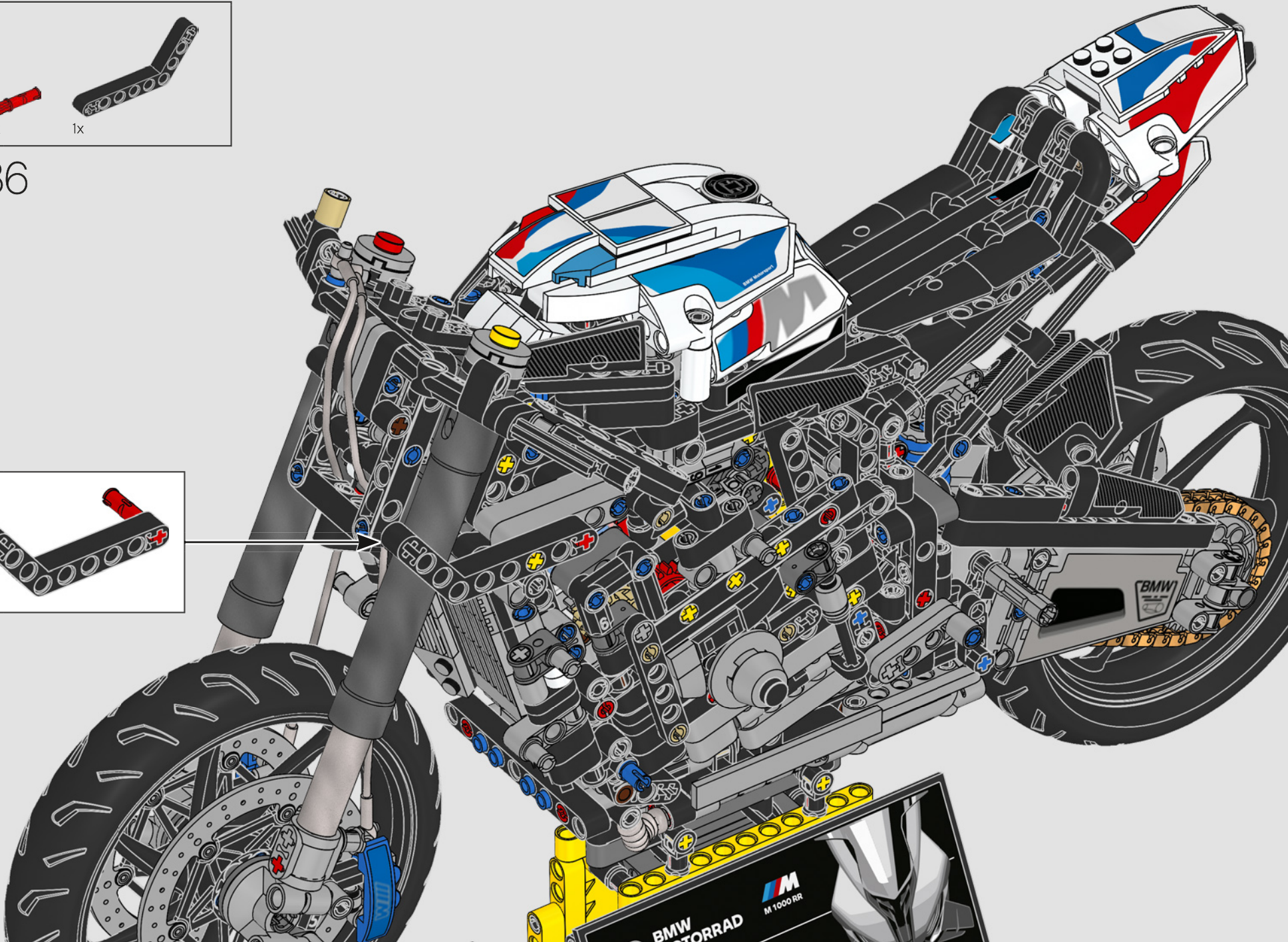
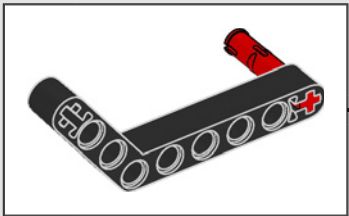

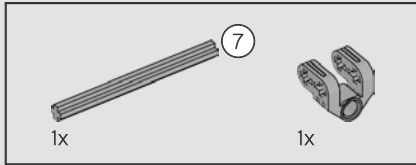
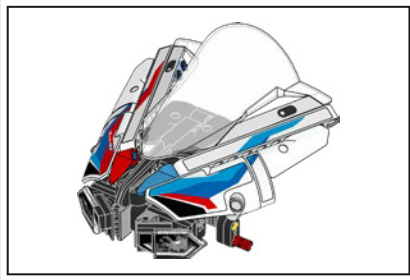

487

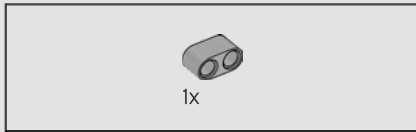
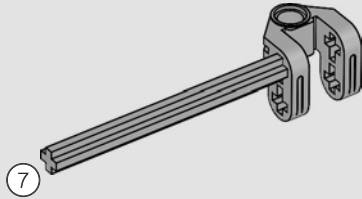

488

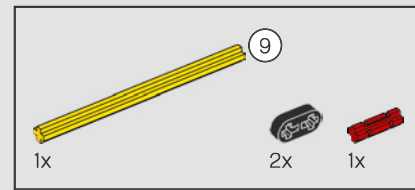
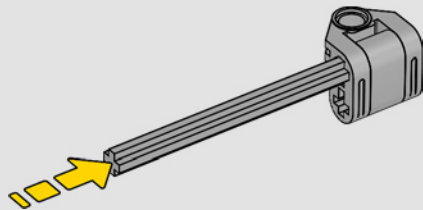

489

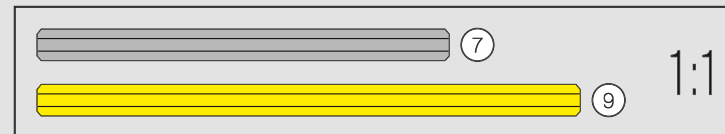
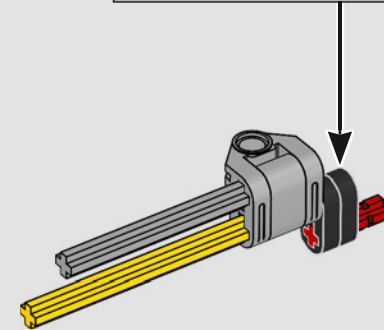
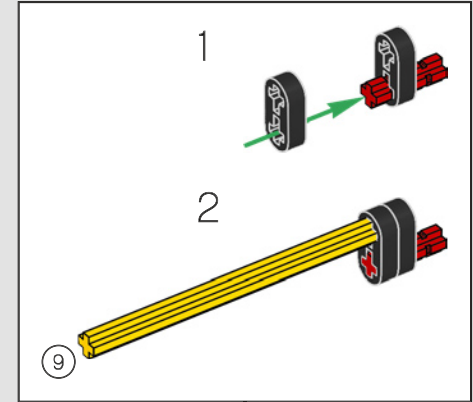

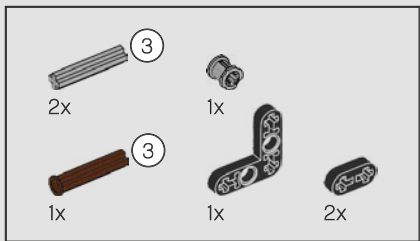

490

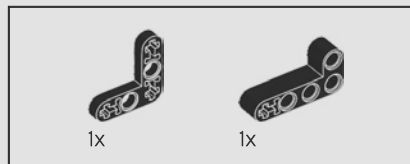
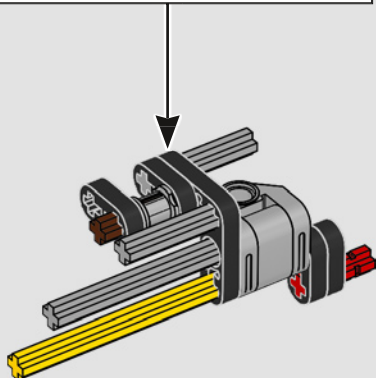
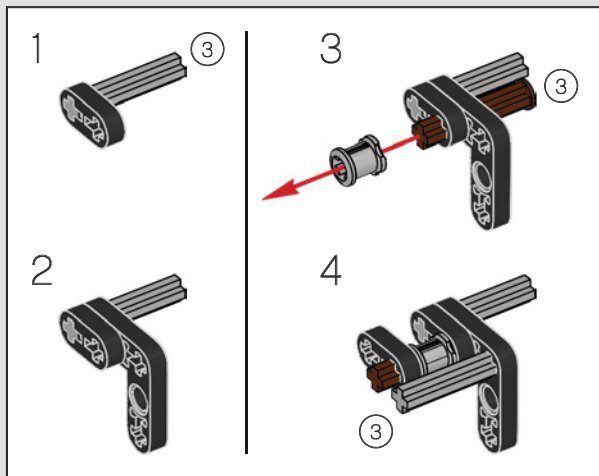

491

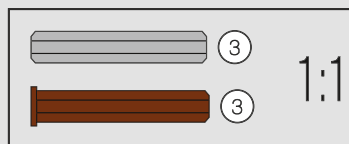
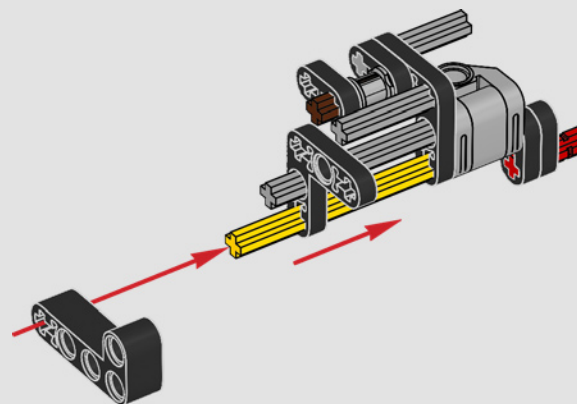

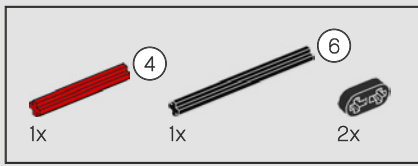

492

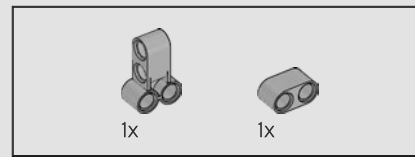
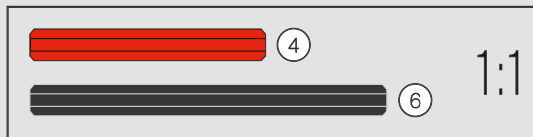
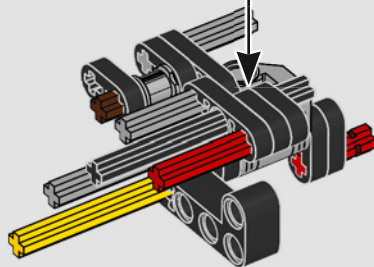
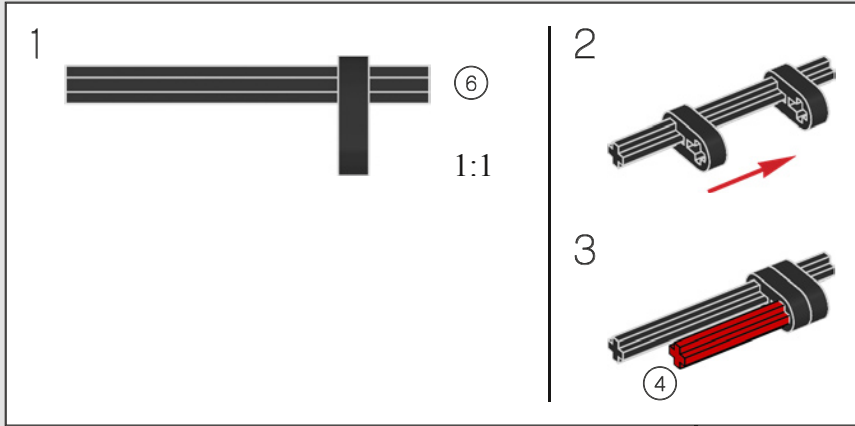

493

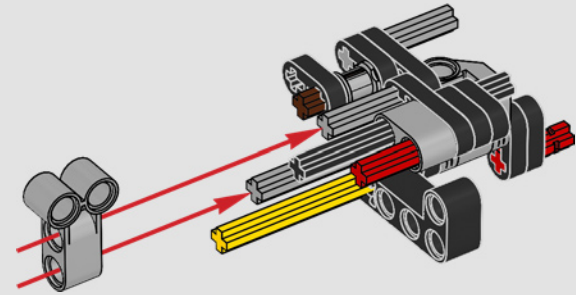

494

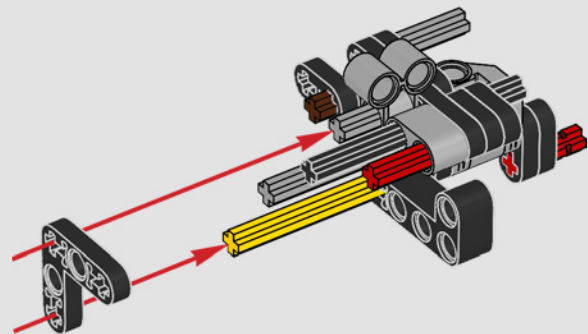

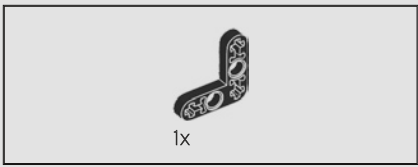

495

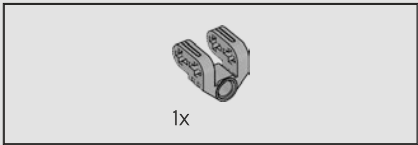
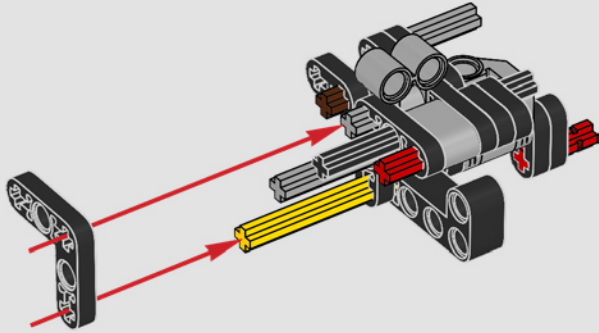

496

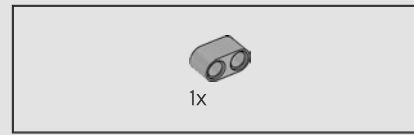
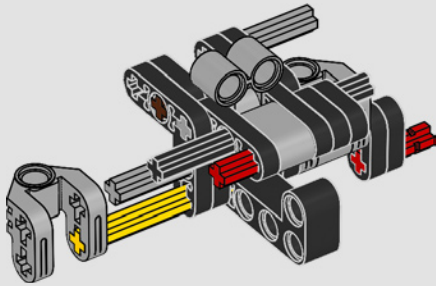

497

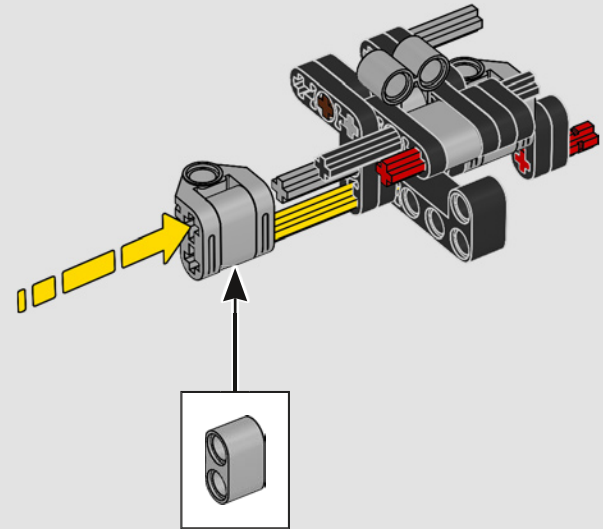

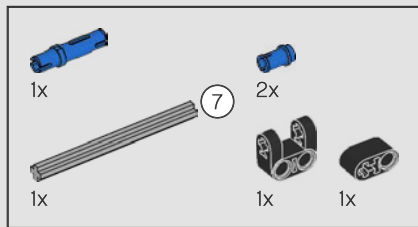

498

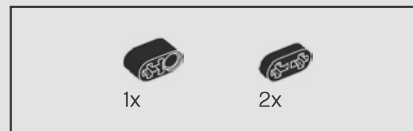
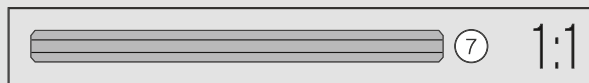
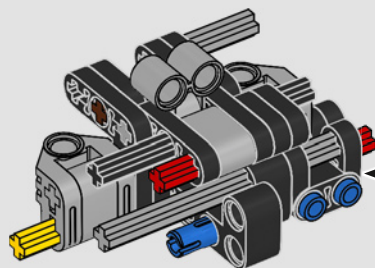
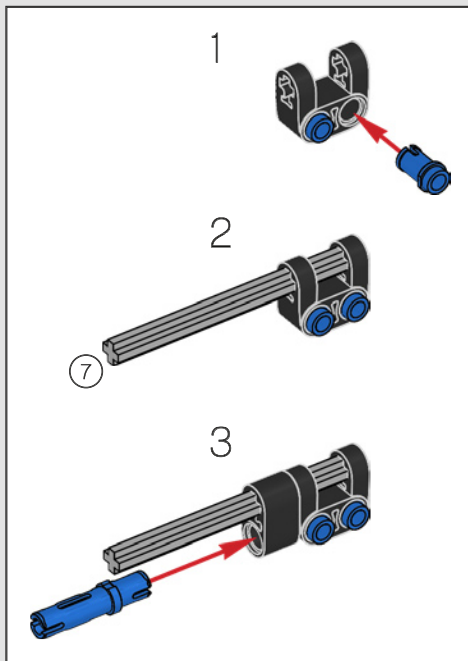

499

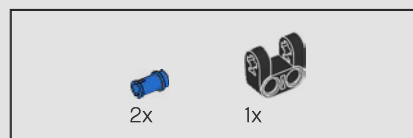
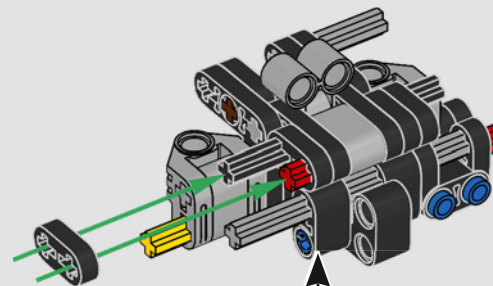

500

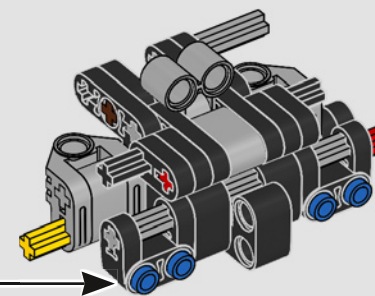
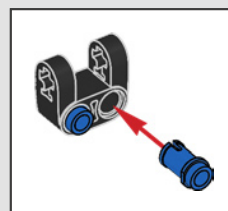



501

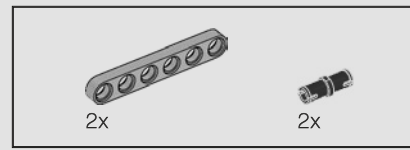
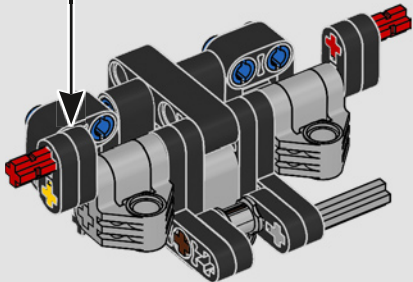
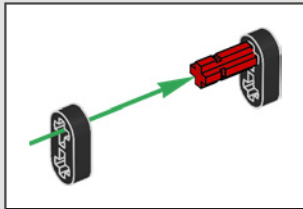

502

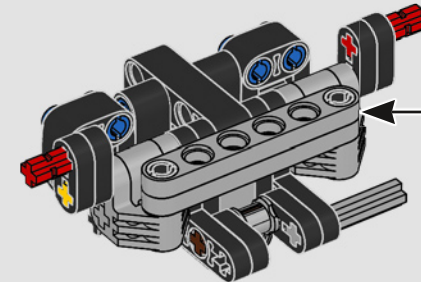
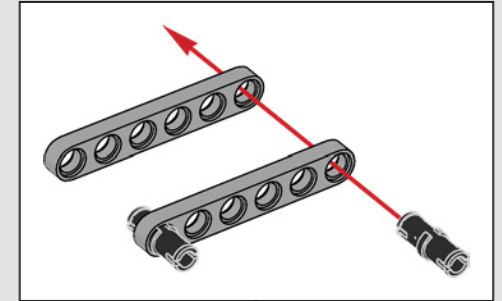

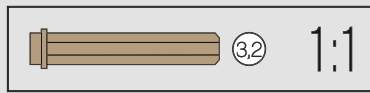
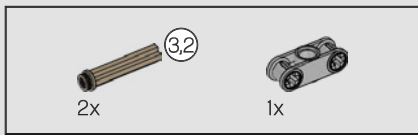

503

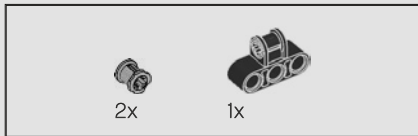
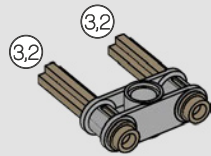

504

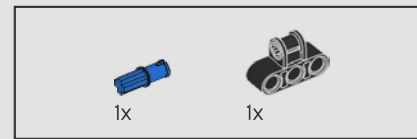
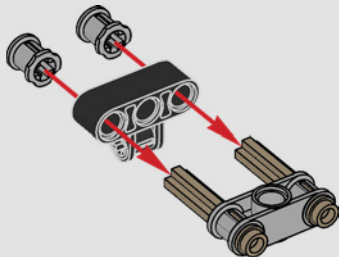

505

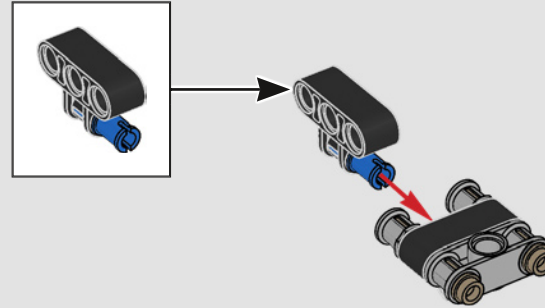

506

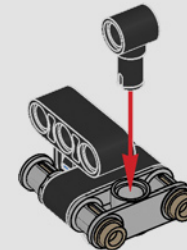

507

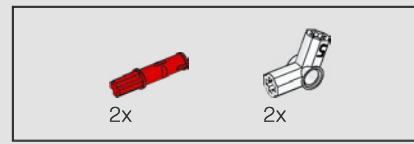
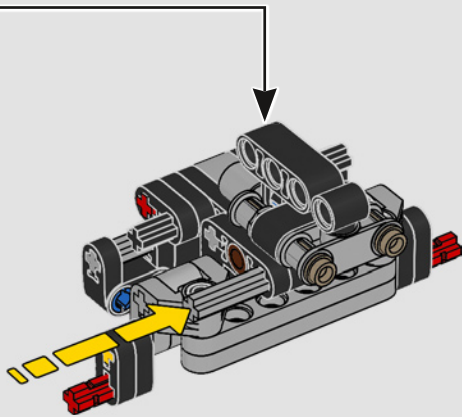

508

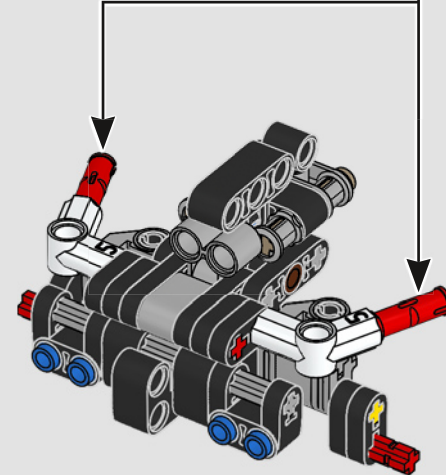
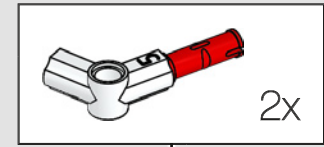

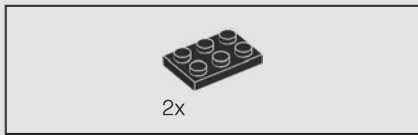

509

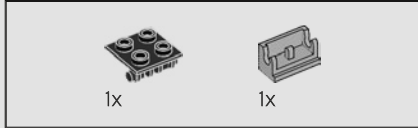
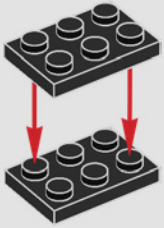

510

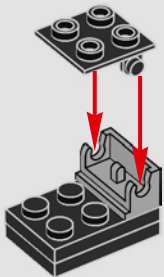

511

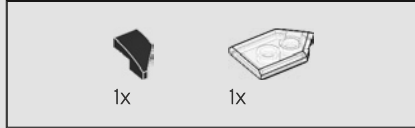
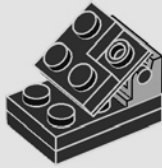

512

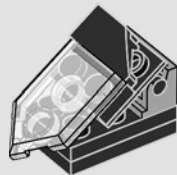

513

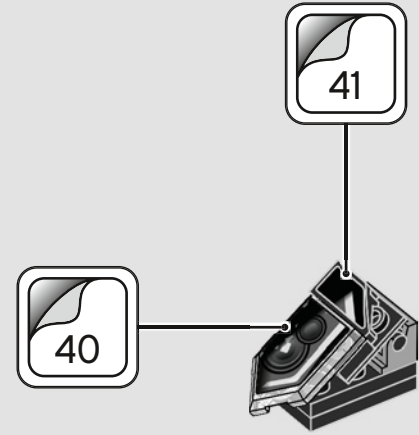

514

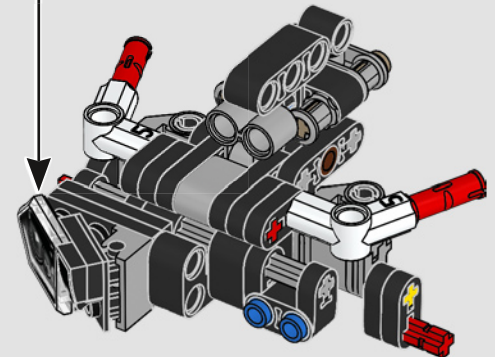

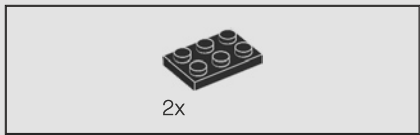

515

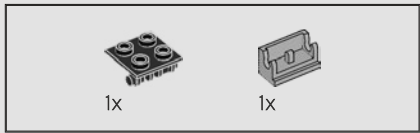
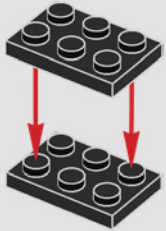

516

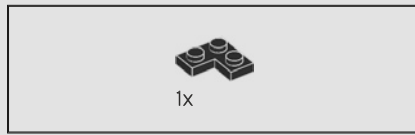
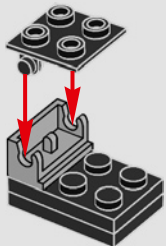

517

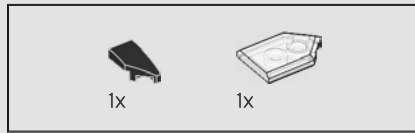
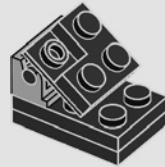

518

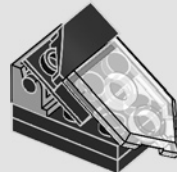

519

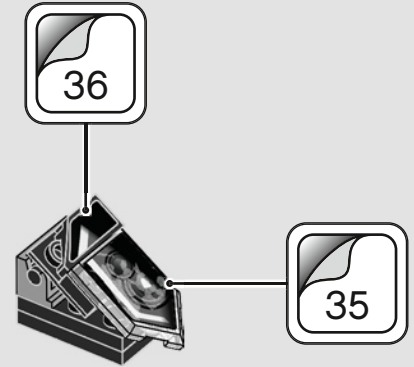

520

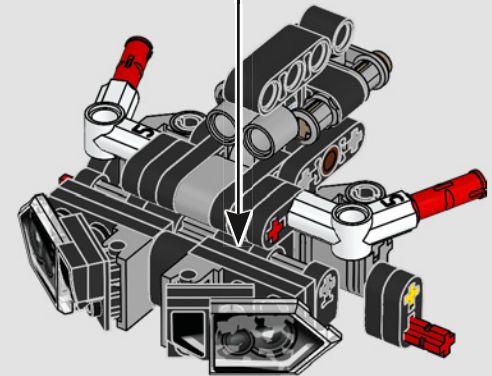

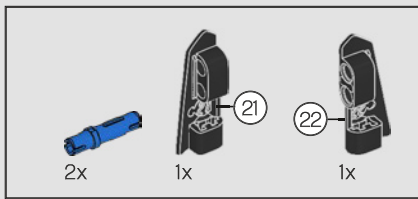

521

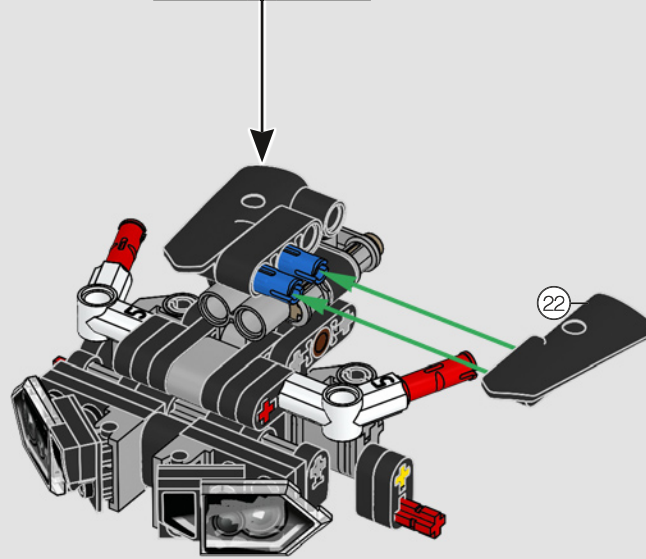
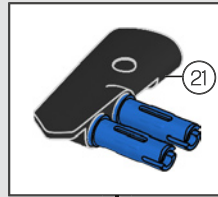

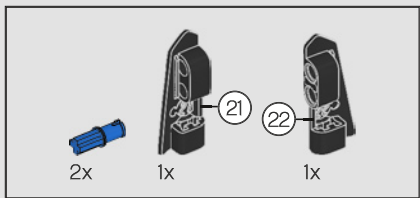

522

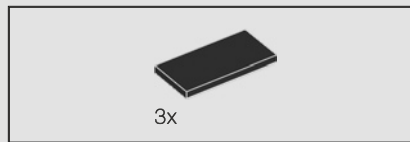
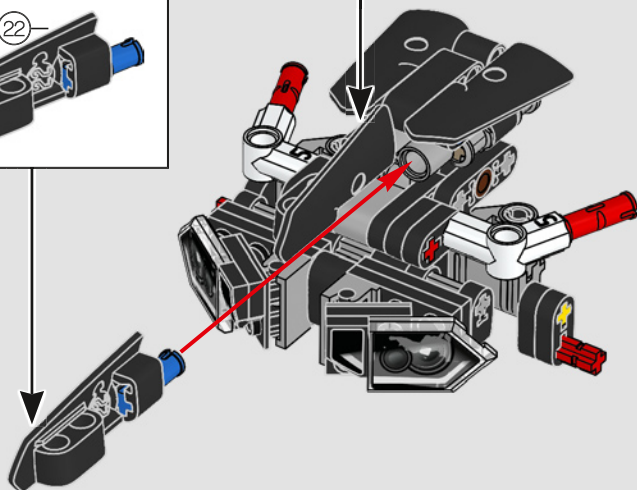
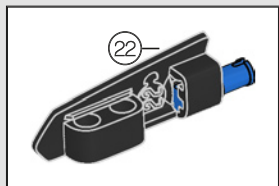
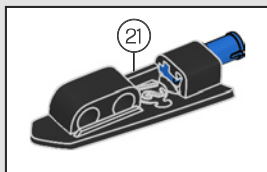

523

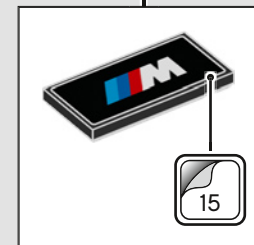
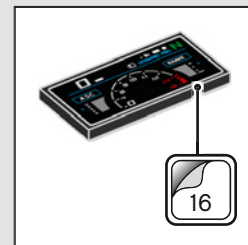
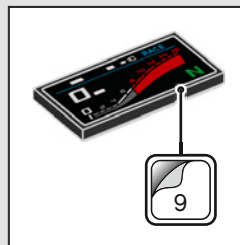
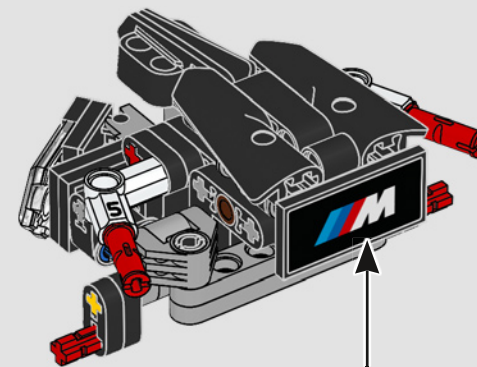

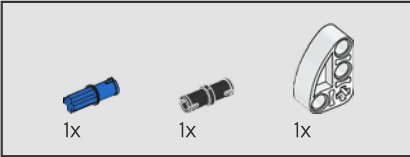
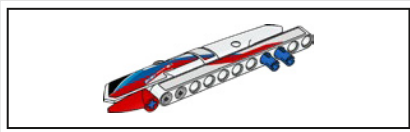

524

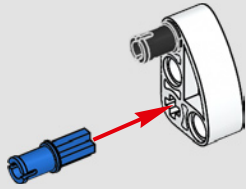

525

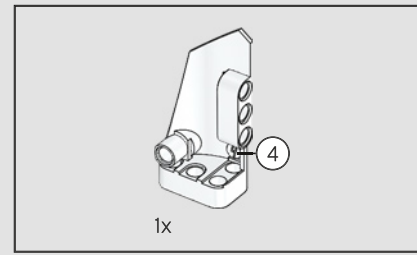
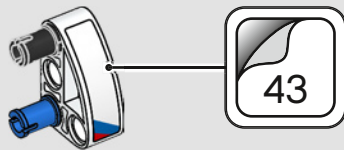

526

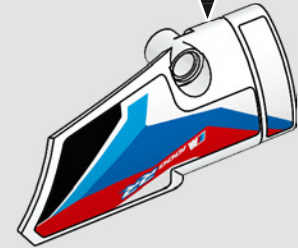

527

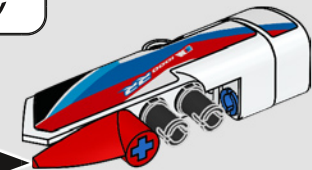
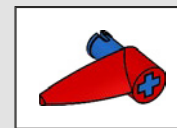
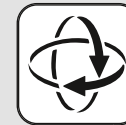

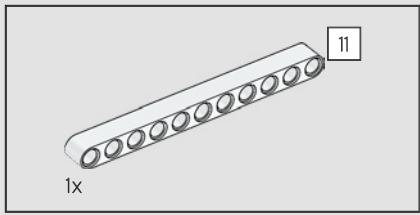

528

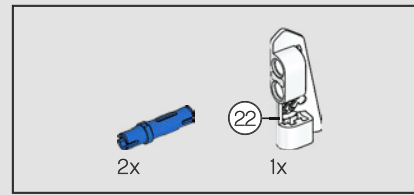
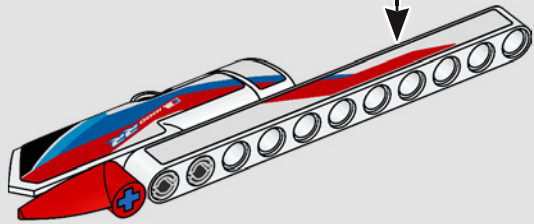
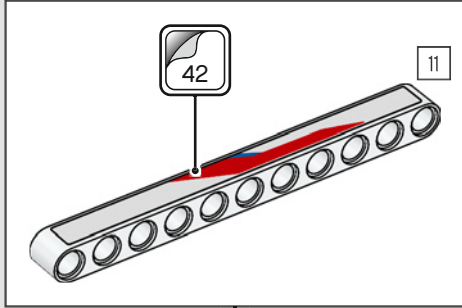

529

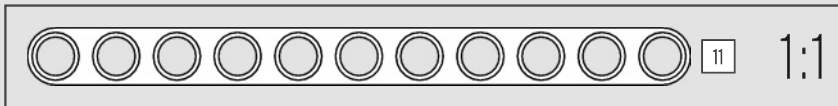
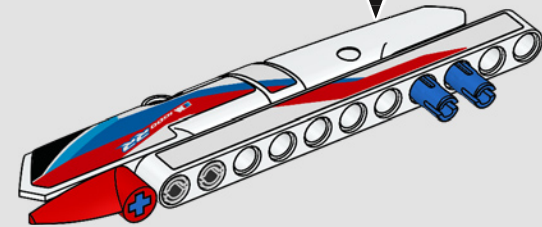
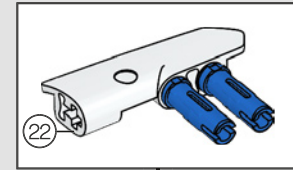

530

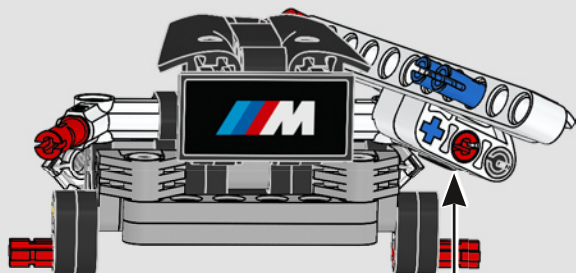

531

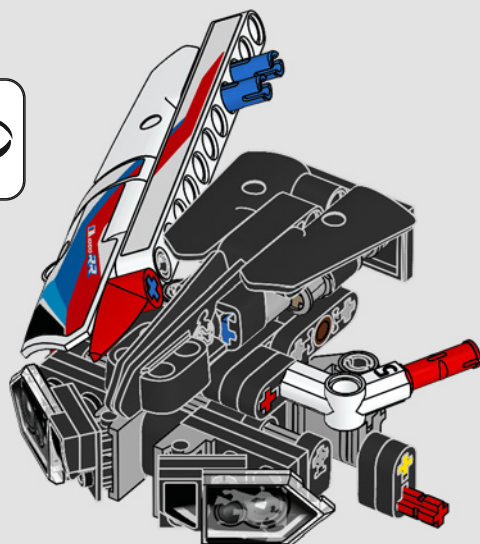

532

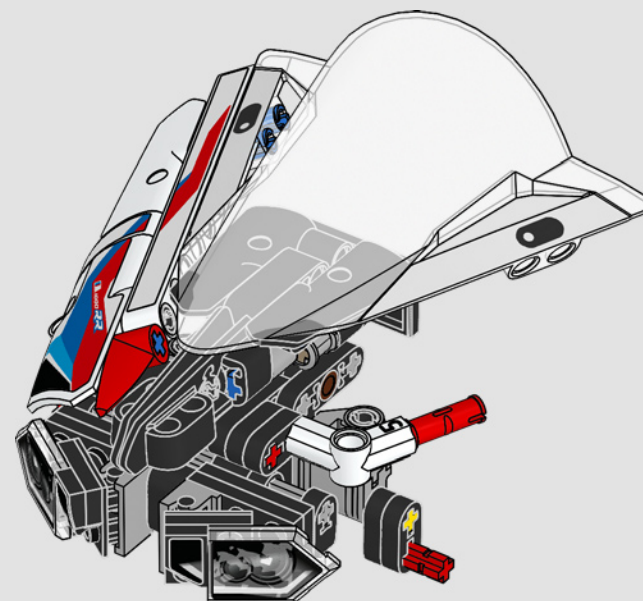
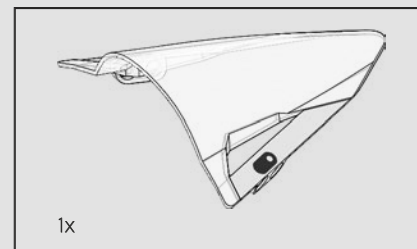

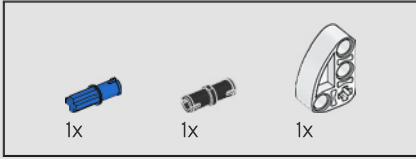
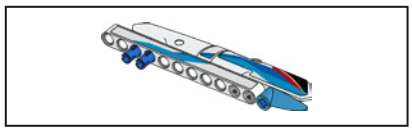

533

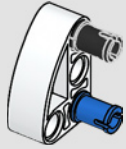

534

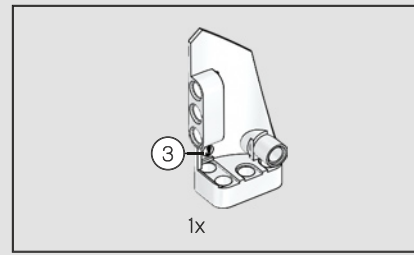
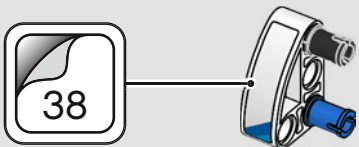

535

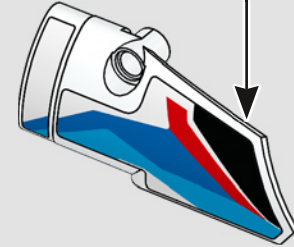
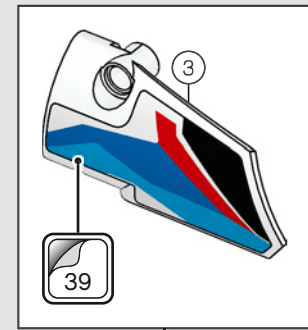

536

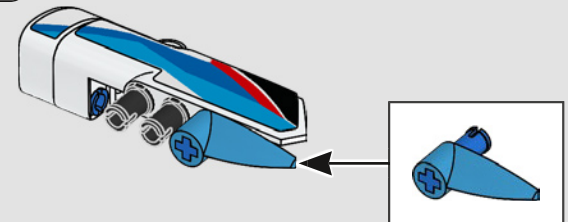
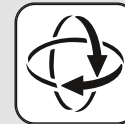

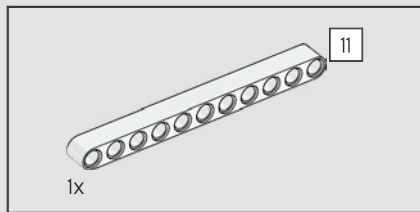

537

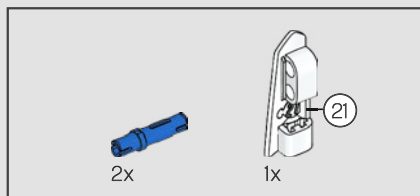
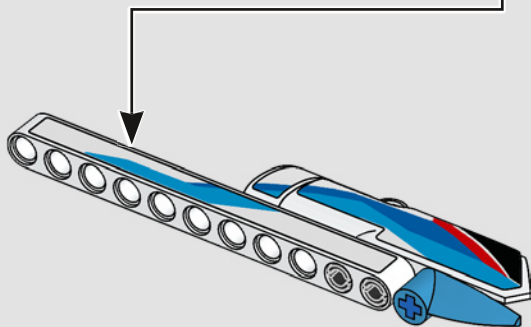
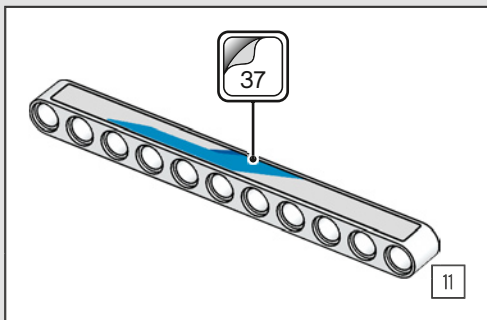

538

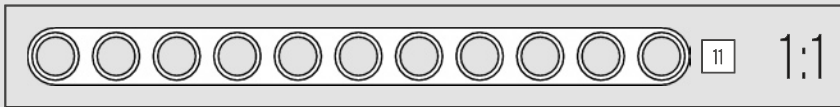
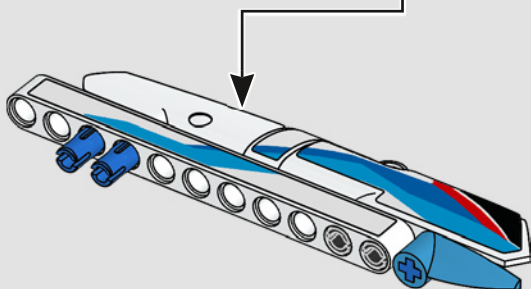
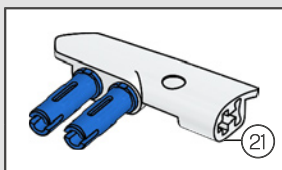

539

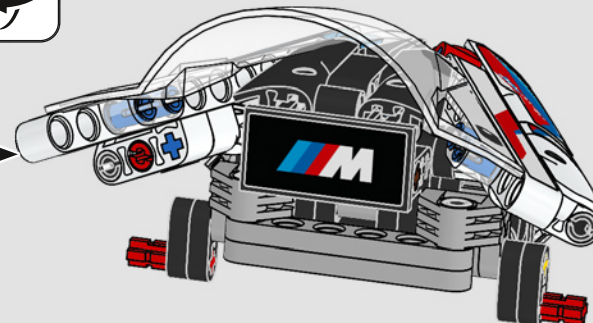

540

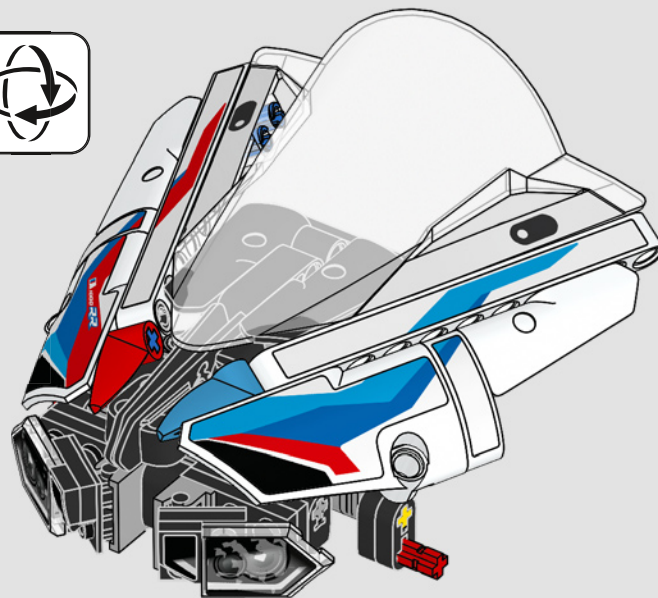

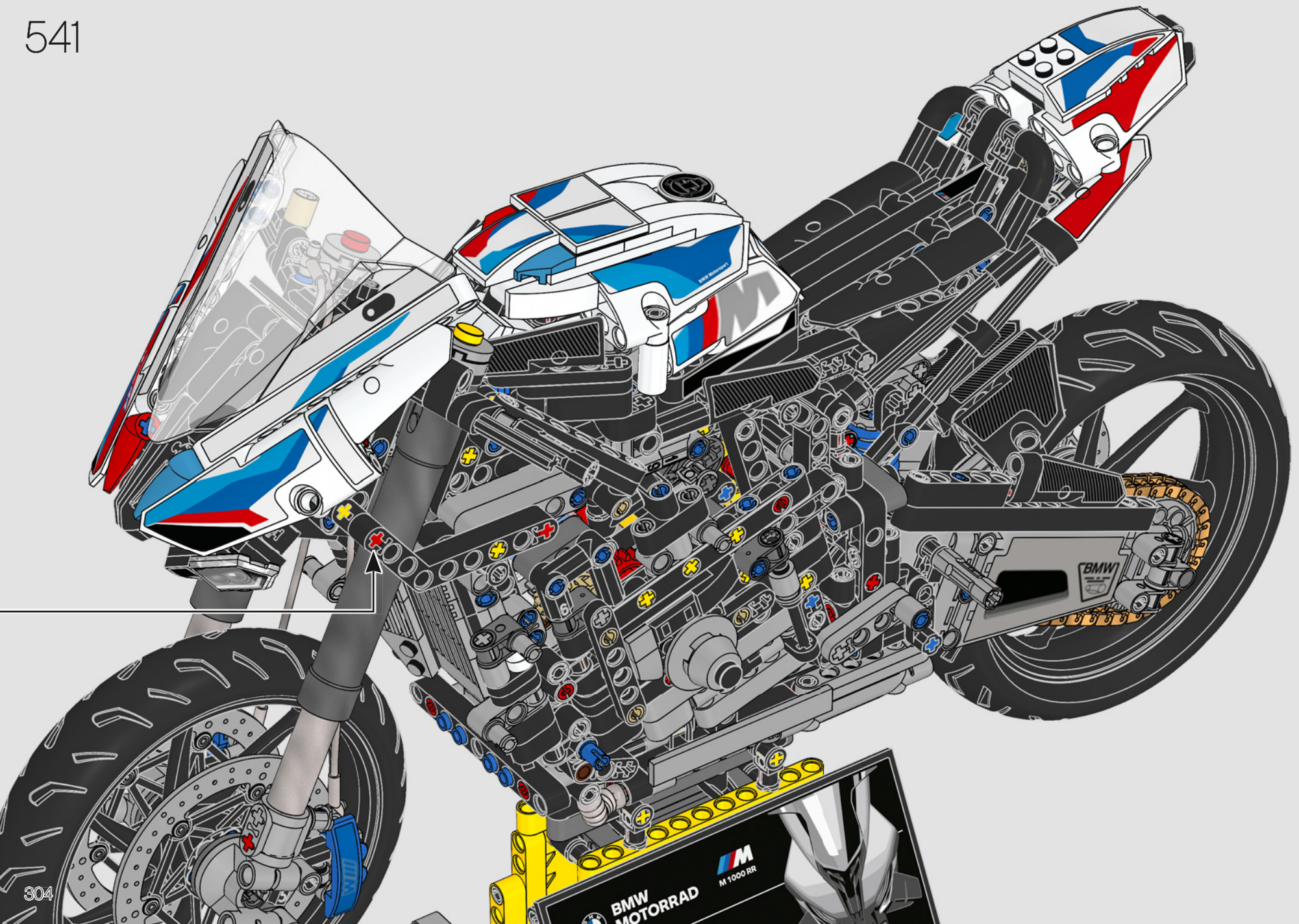

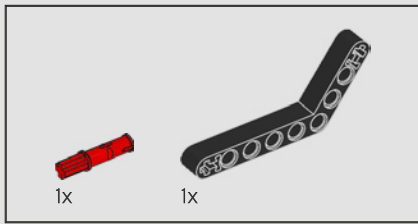

542

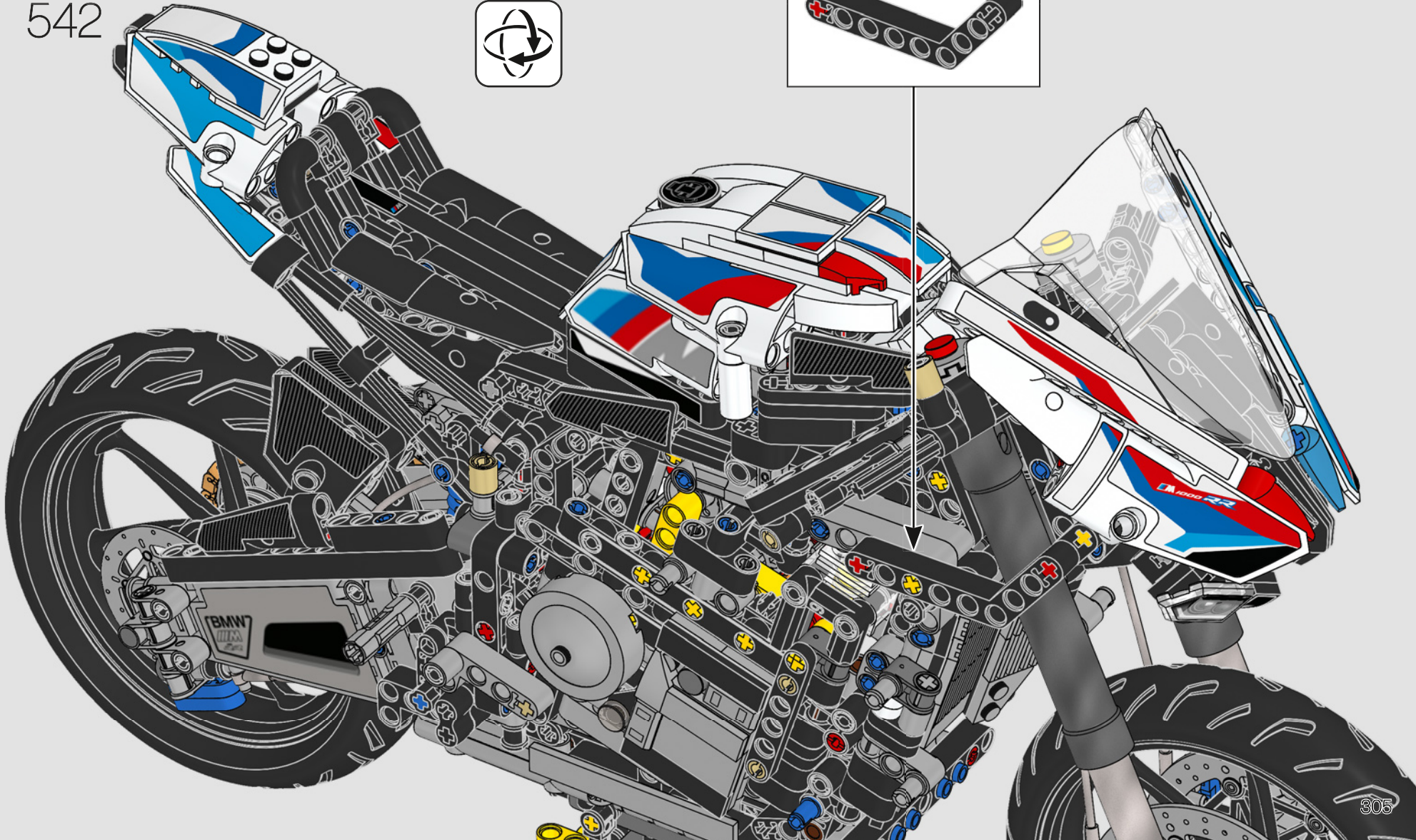
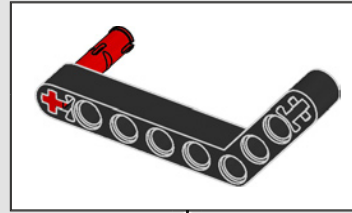

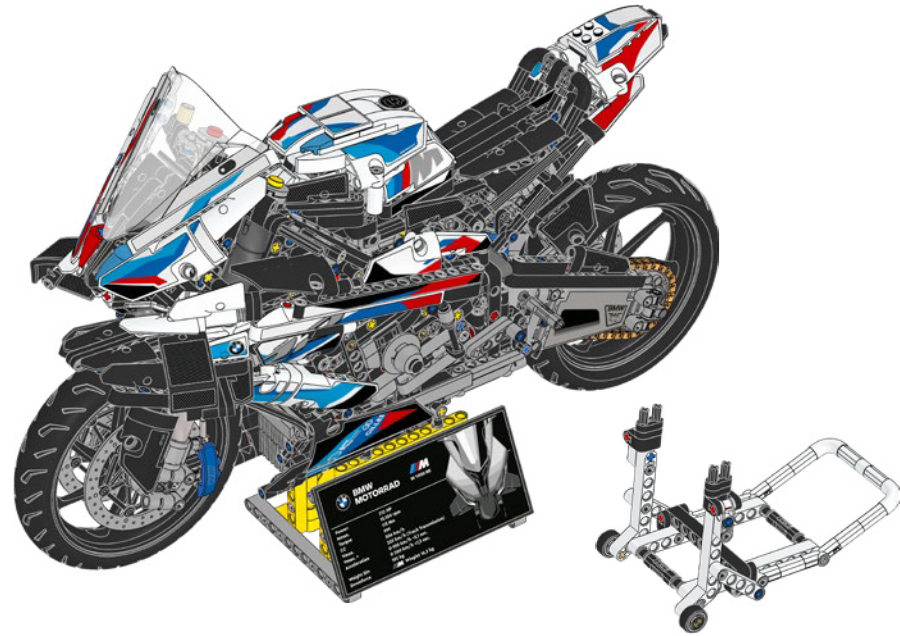
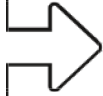

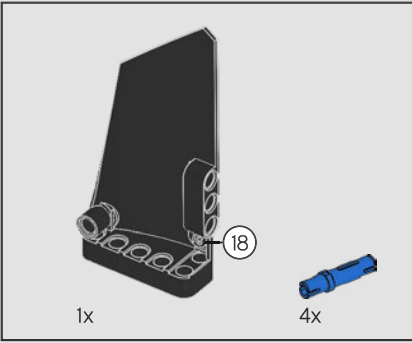
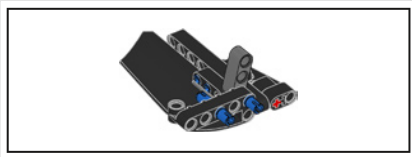

543

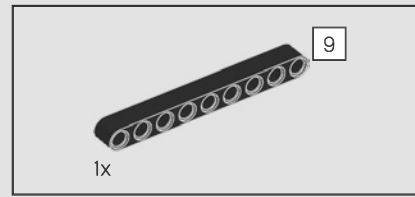
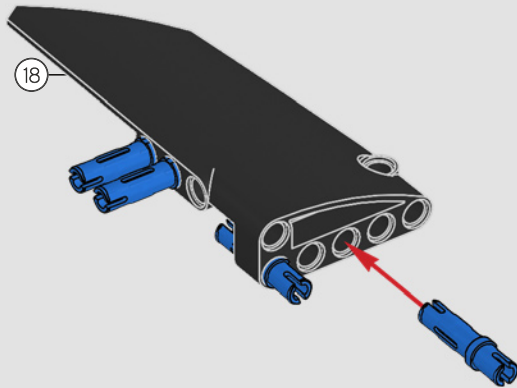

544

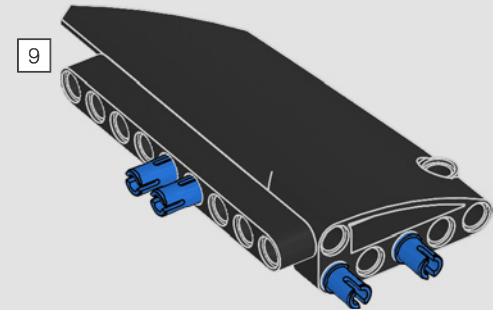

545

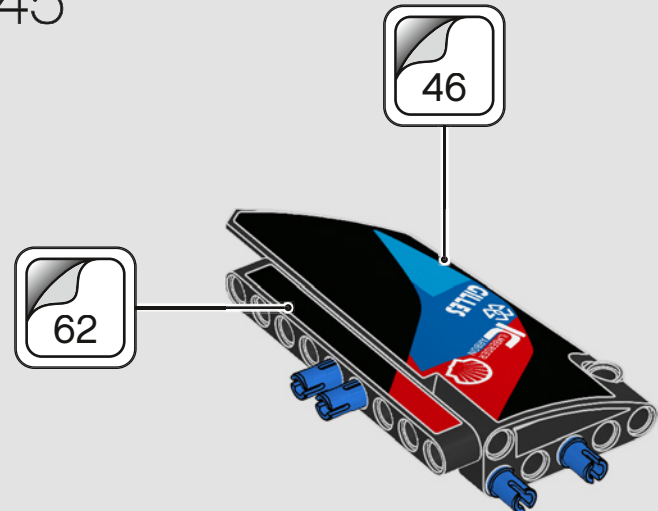

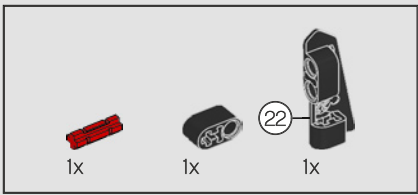

546

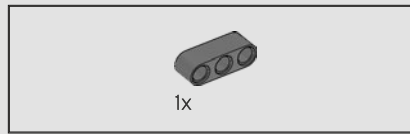
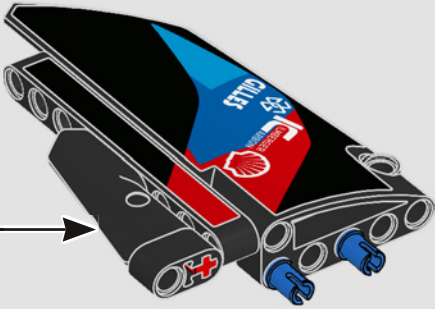
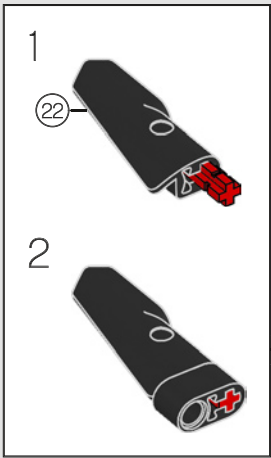

547

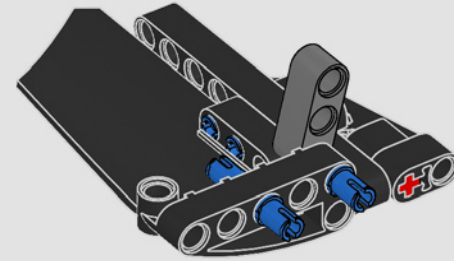

548

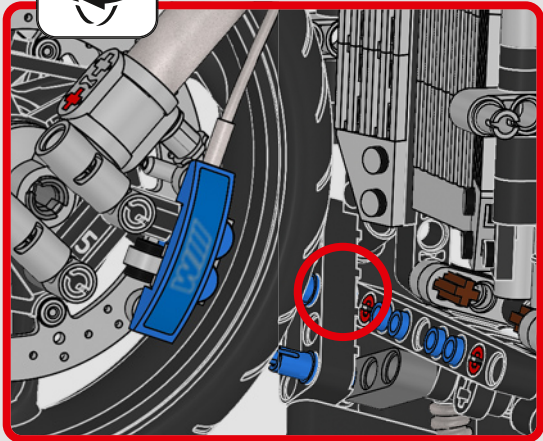
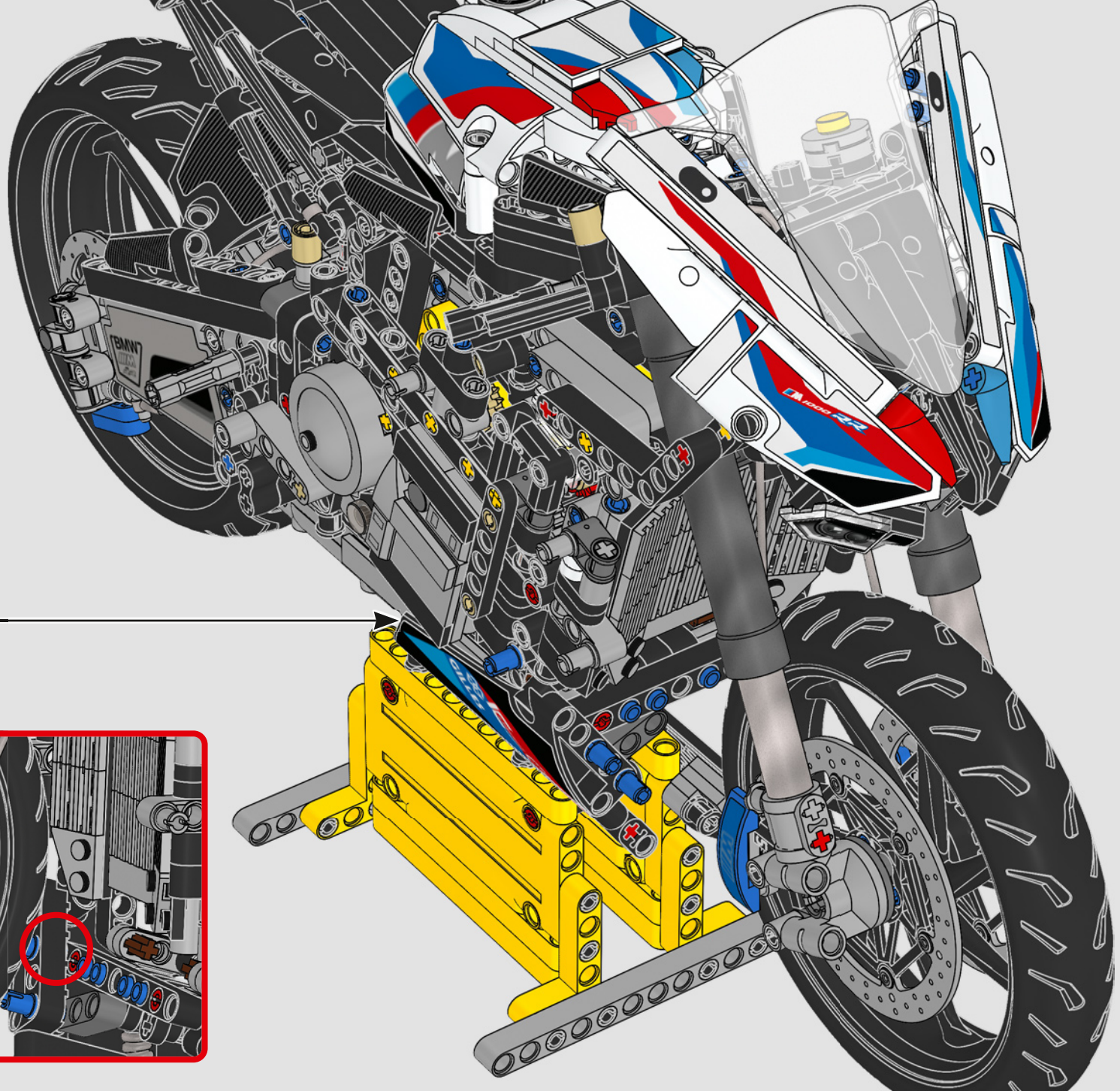

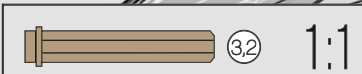
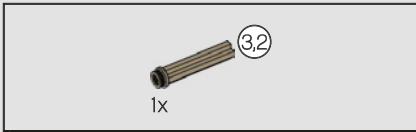

549

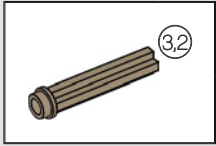
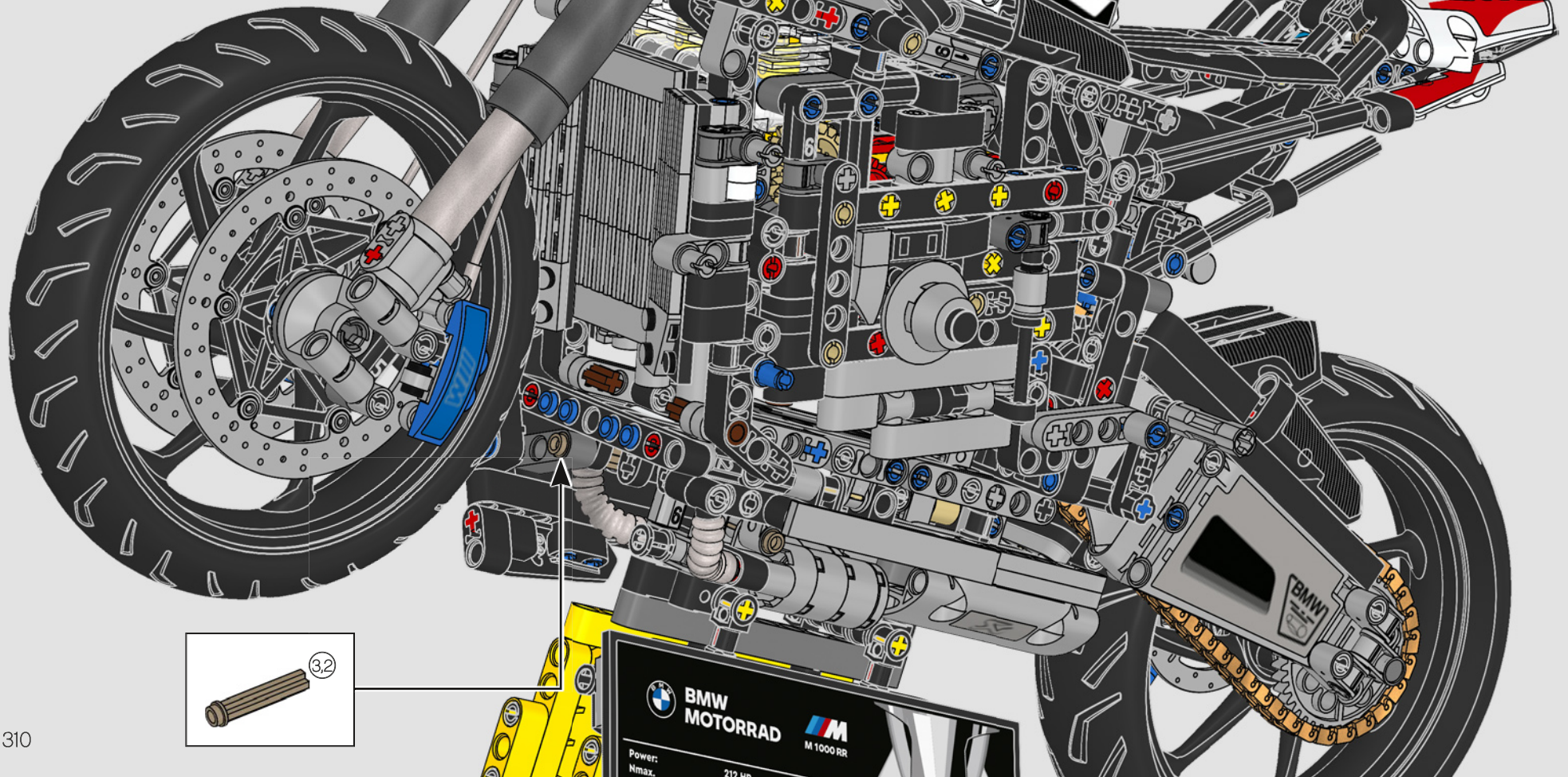

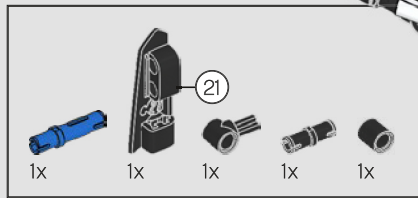

550

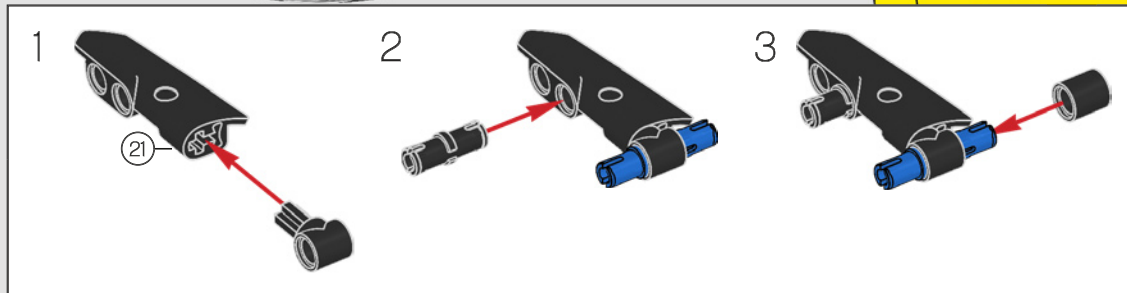
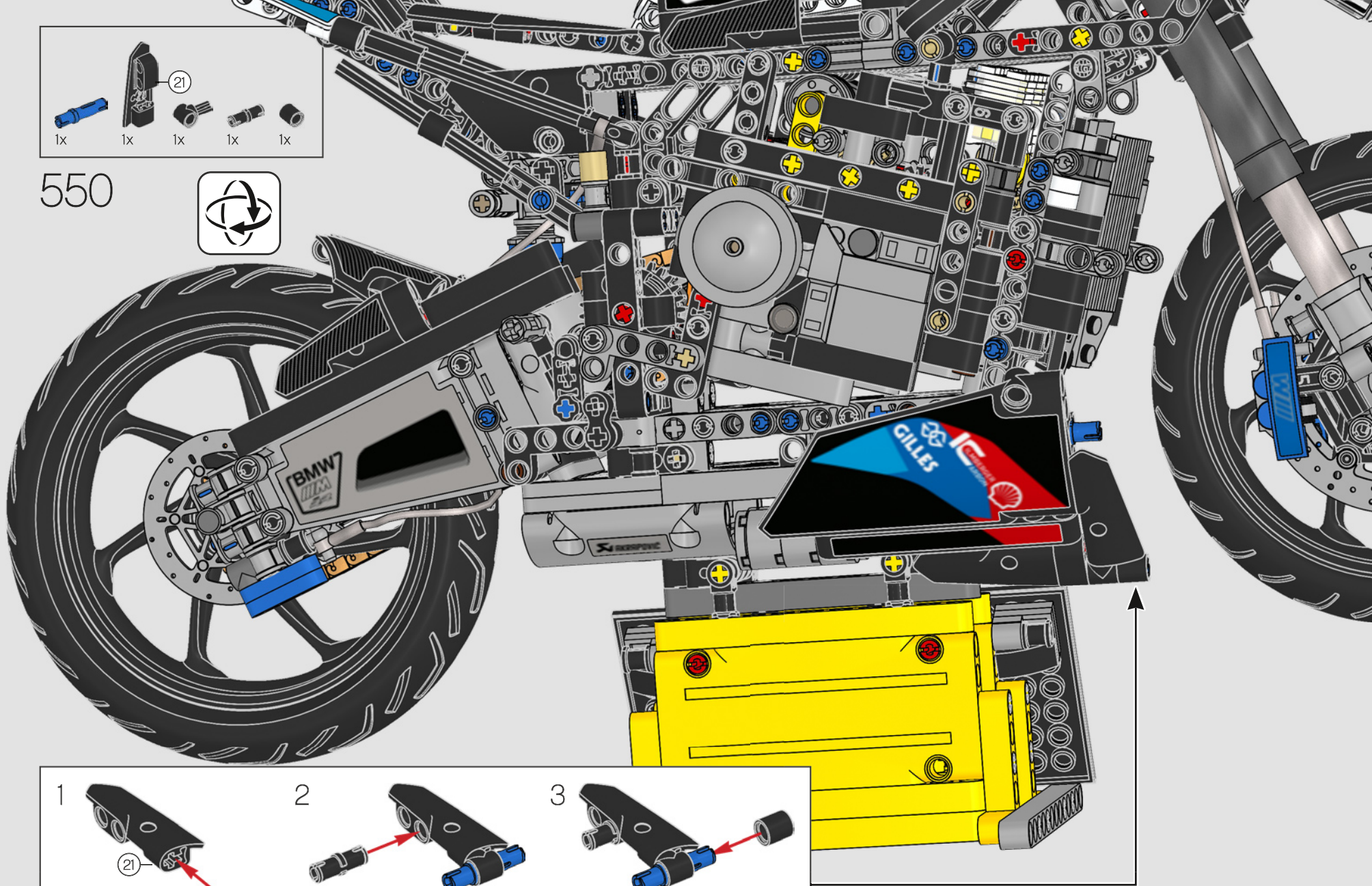

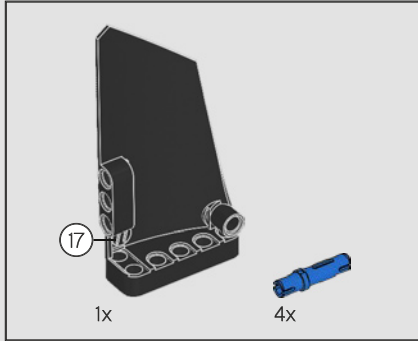
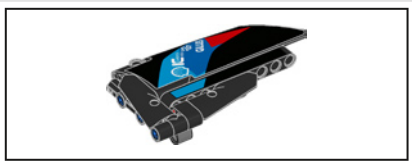

551

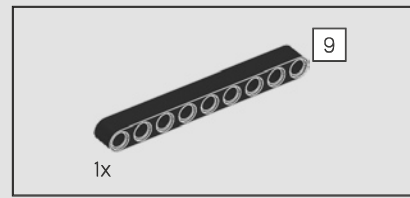
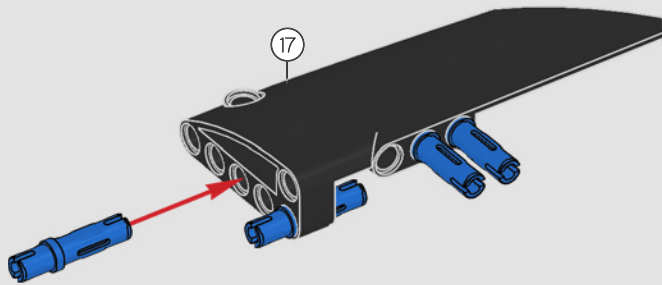

552

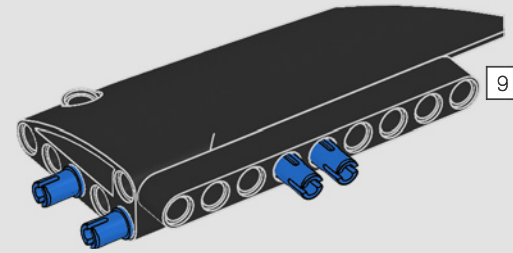

553

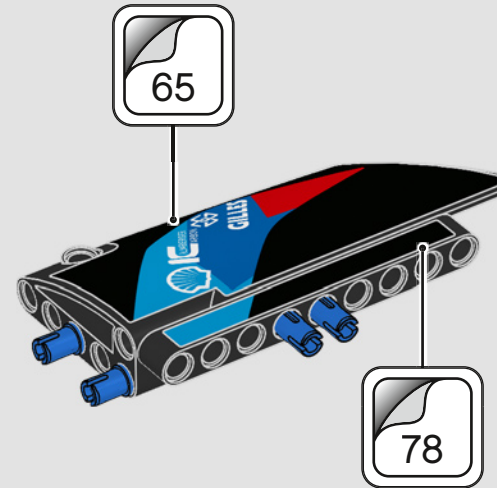

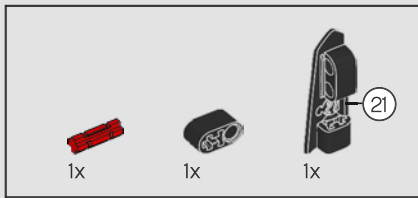

554

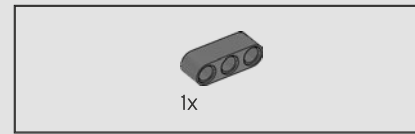
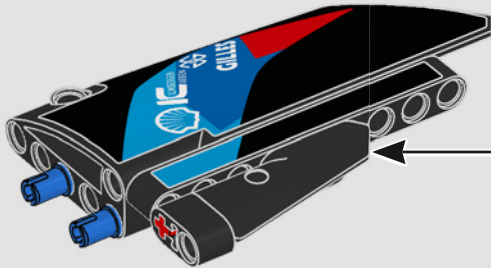
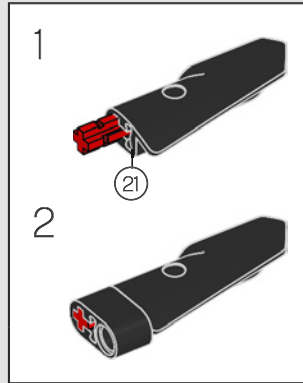

555

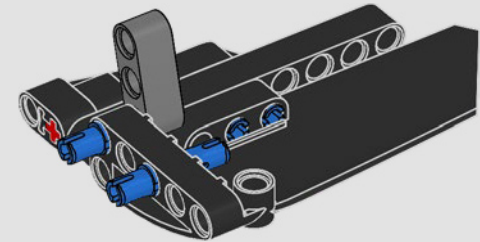

556

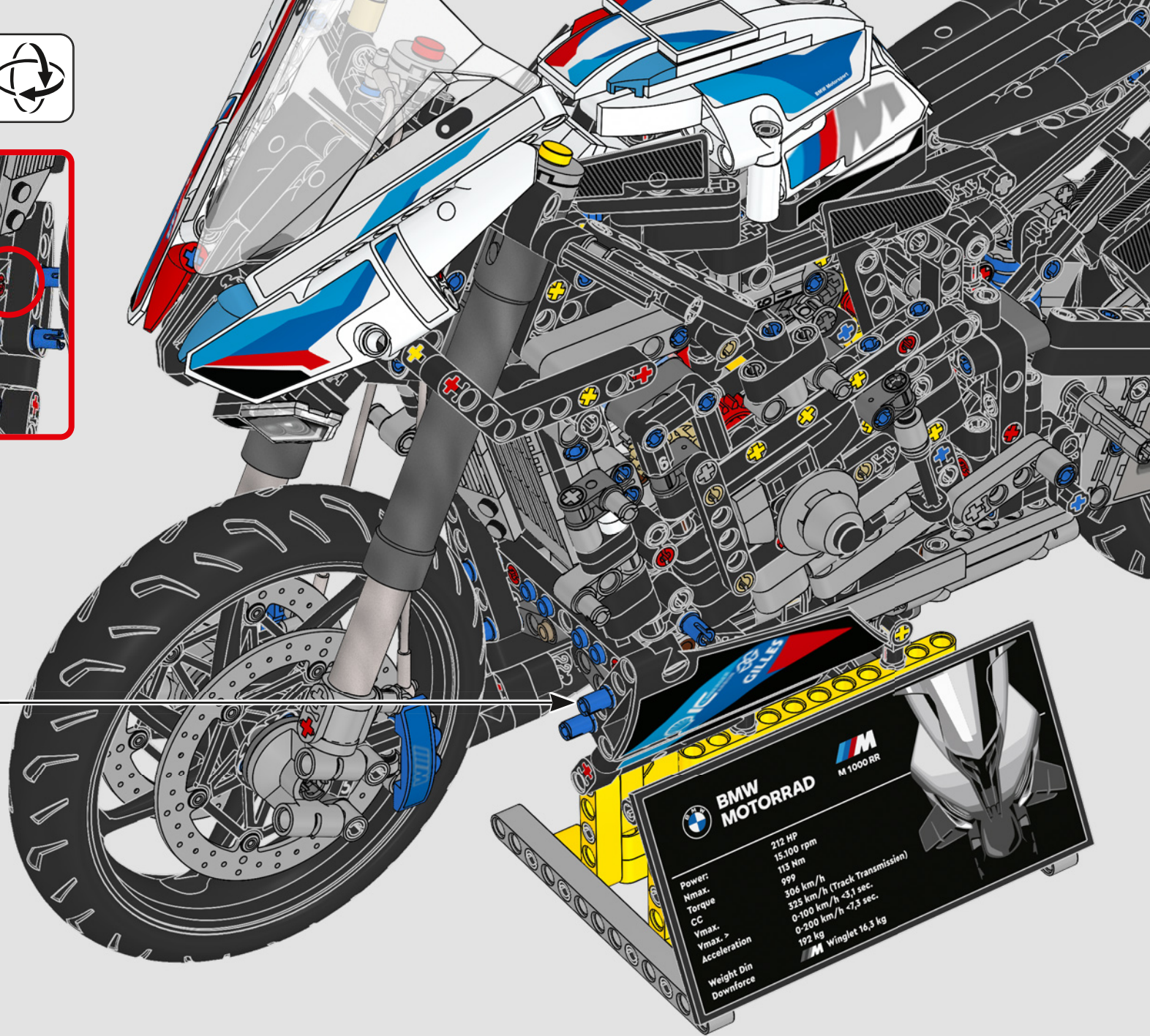
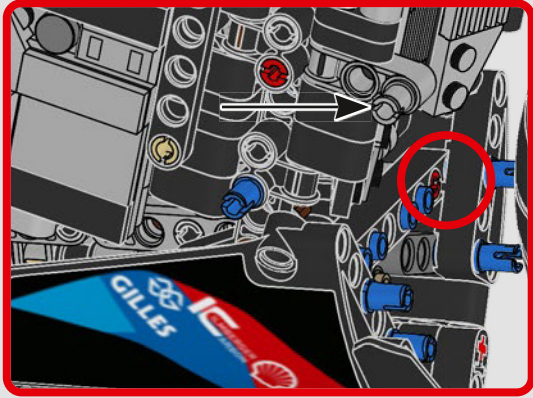

BMW MOTORRAD M 1000 RR

Power:	212 HP
Nmax:	15,100 rpm
Torque:	113 Nm
CC	999
Vmax:	306 km/h
Acceleration	0-100 km/h <3,1 sec.
Weight Din	0-200 km/h <7,3 sec.
Downforce	192 kg
	Winglet 16,3 kg

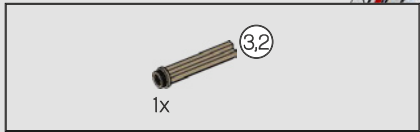

557

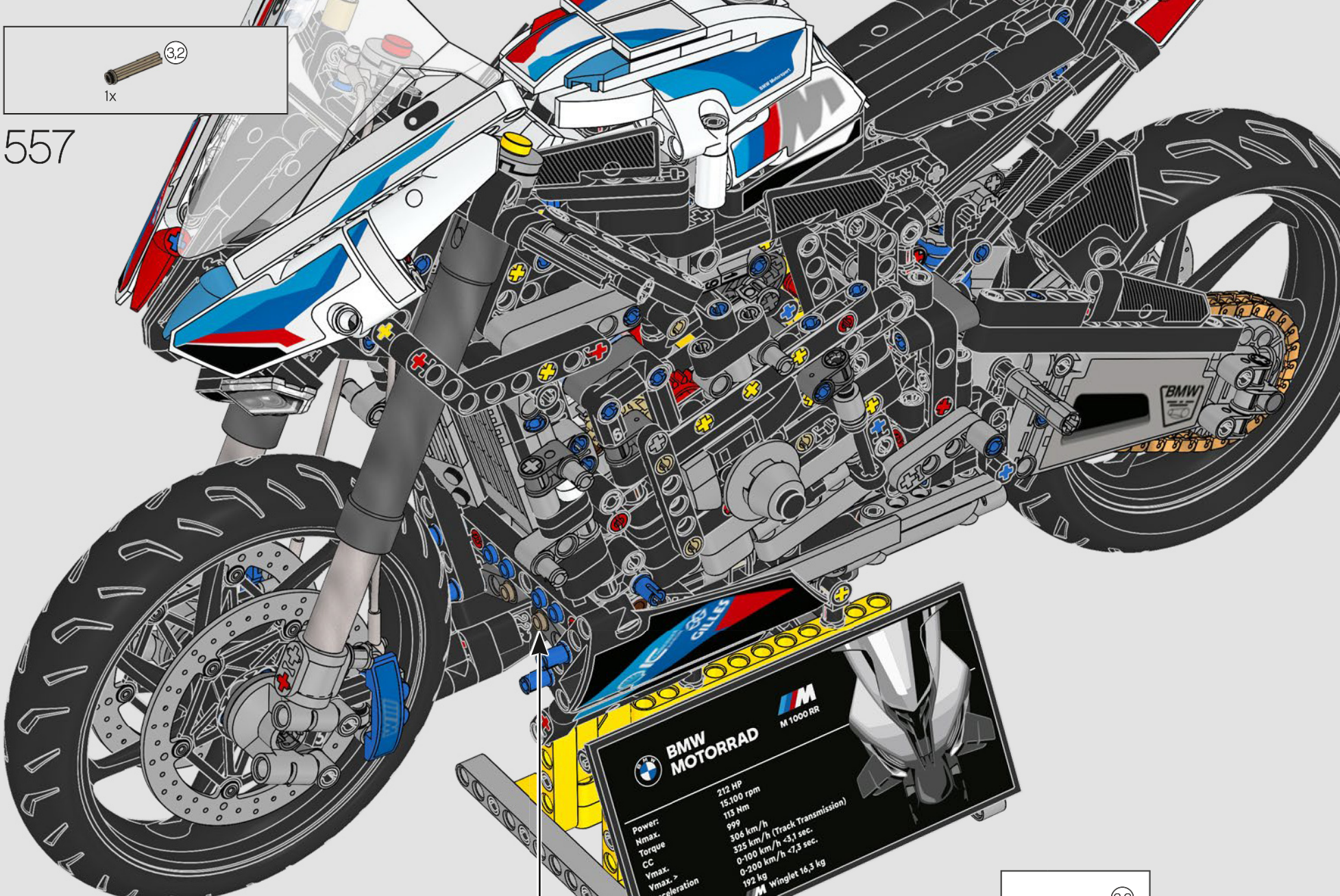

BMW MOTORRAD M 1000 RR

Power:	212 HP
Nmax:	15,100 rpm
Torque:	113 Nm
CC	999
Ymax.	306 km/h (Track Transmission)
Acceleration	0-100 km/h <3,1 sec.
Weight Din	0-200 km/h <7,3 sec.
Downforce	192 kg
	Winglet 16,3 kg

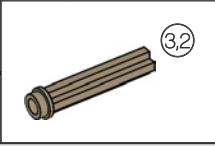

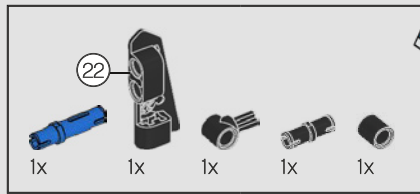

558

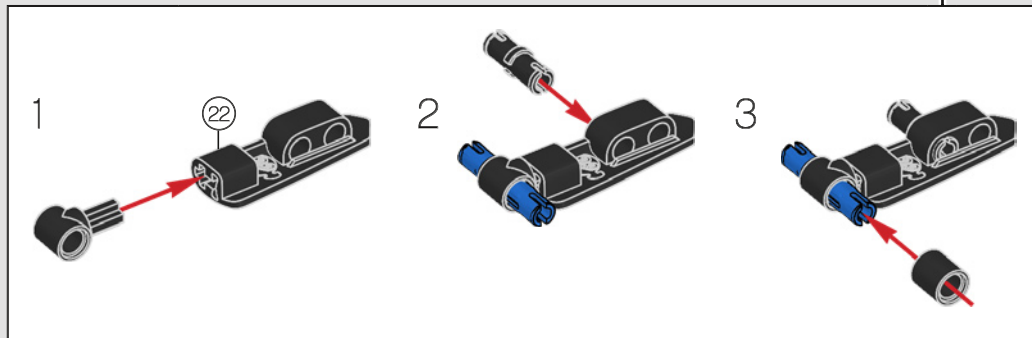
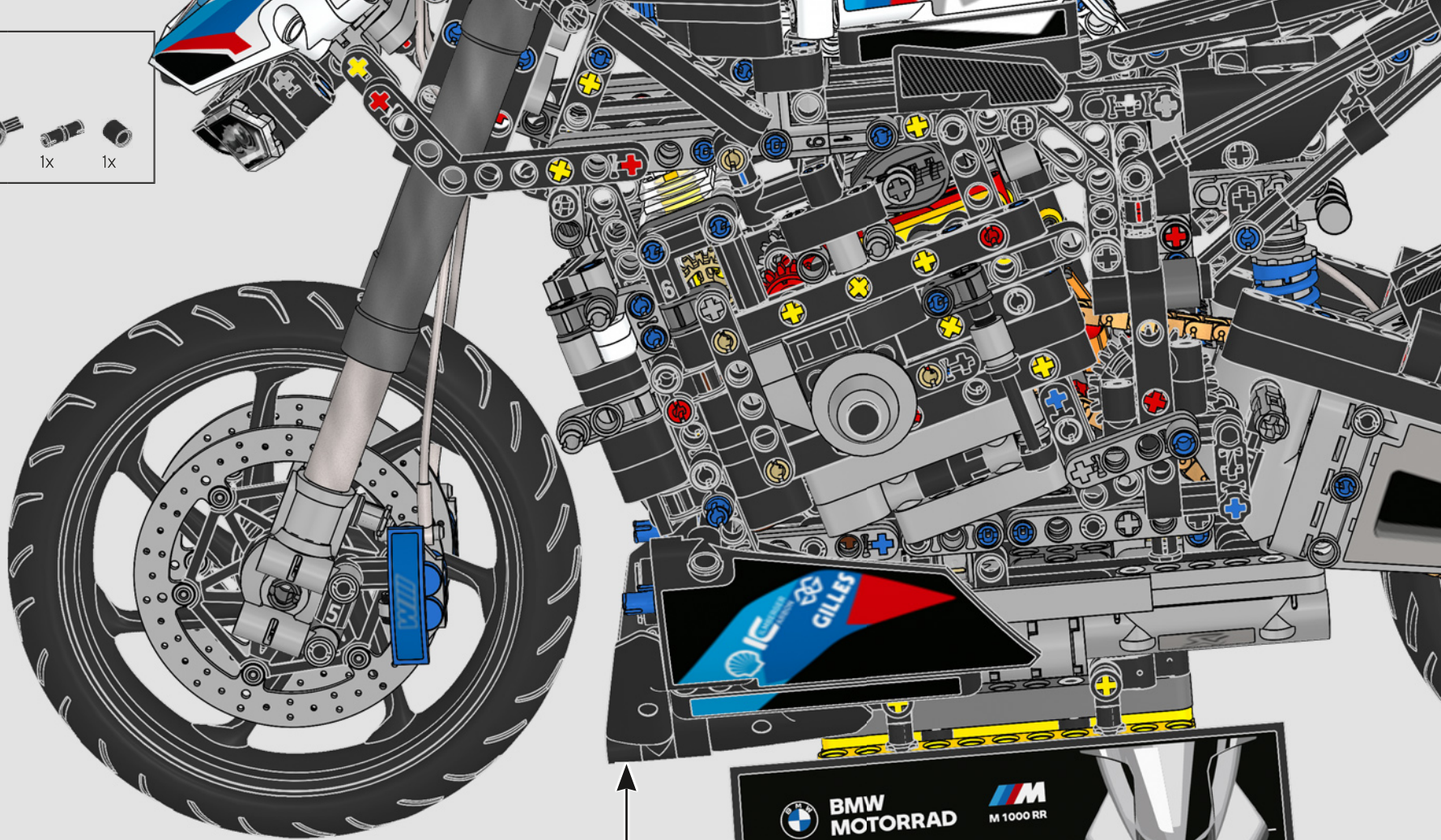

BMW MOTORRAD **M 1000 RR**

Power:	212 HP
Nmax.	15.100 rpm
Torque	113 Nm
CC	999
Vmax.	306 km/h
Vmax. >	325 km/h (Track Transmission)
Acceleration	0-100 km/h <3,1 sec.
	0-200 km/h <7,3 sec.
Weight Din	192 kg
Downforce	M Winglet 16,3 kg

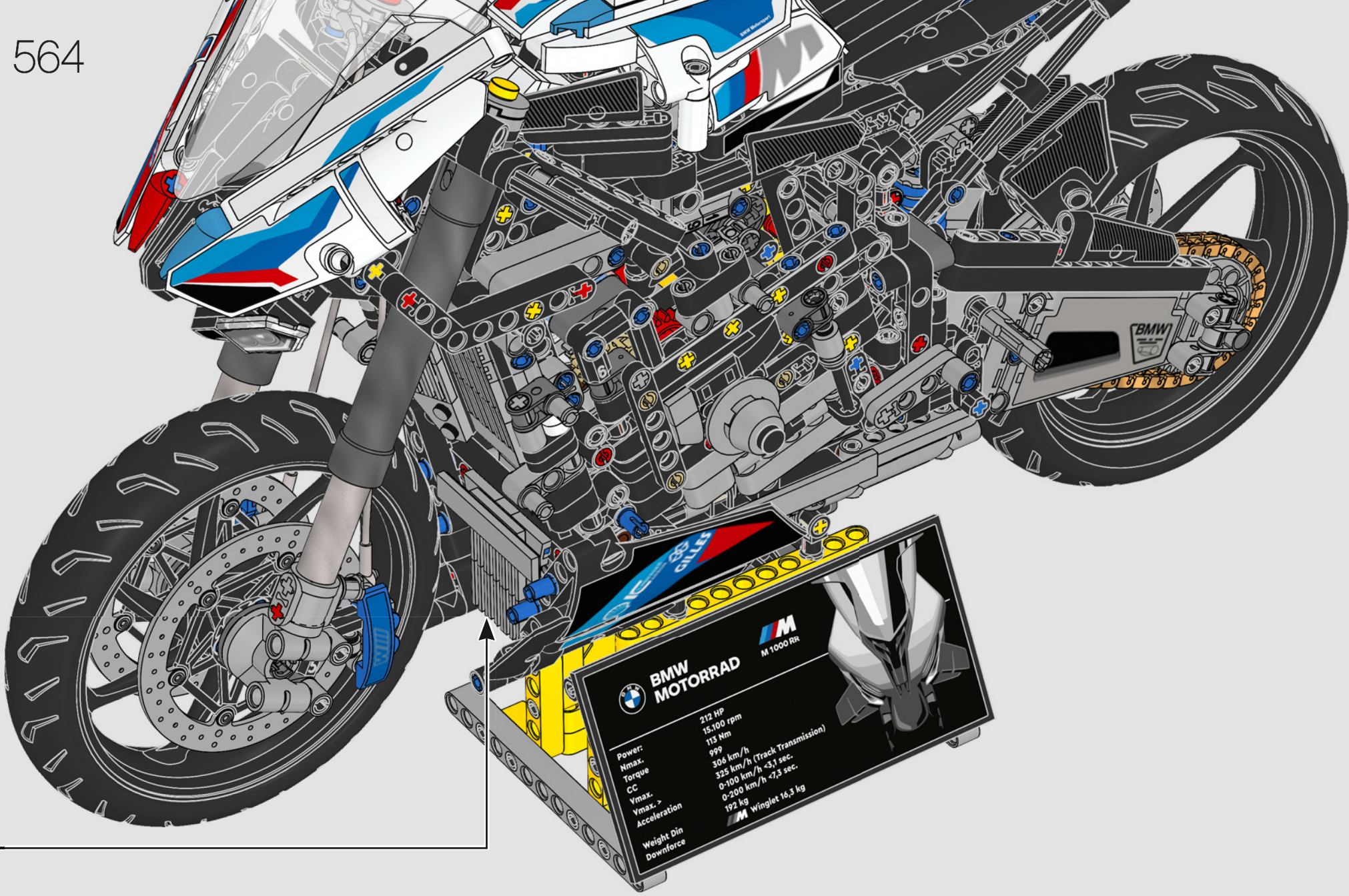

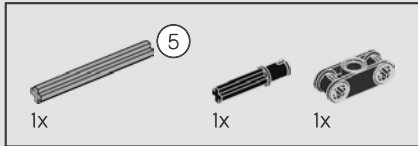
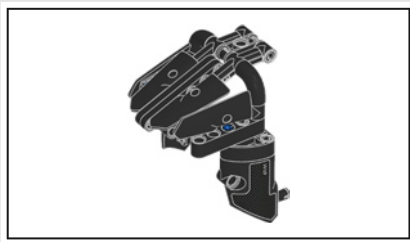

565

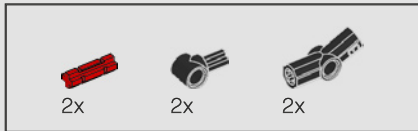
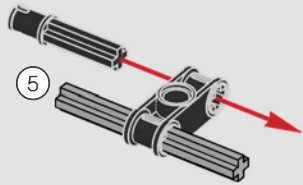

566

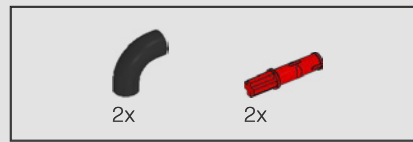
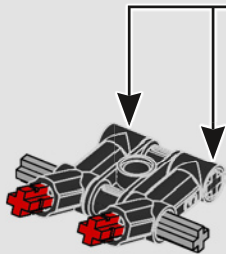
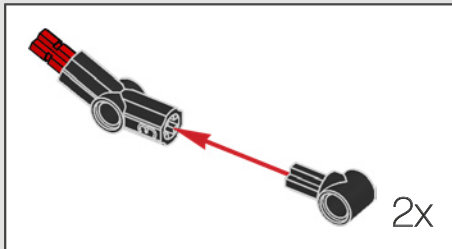

567

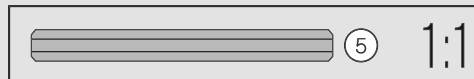
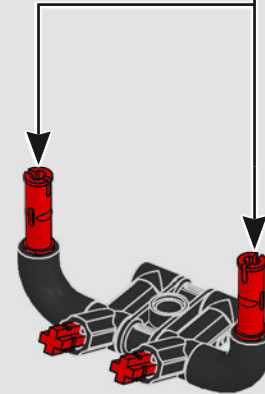
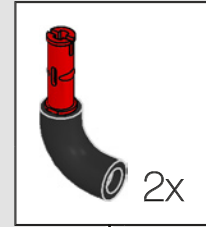

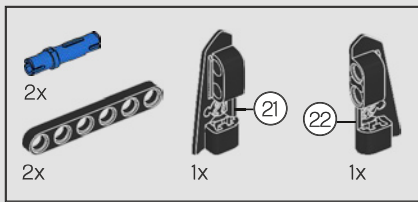

568

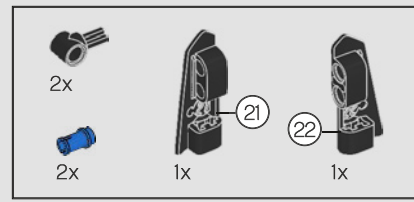
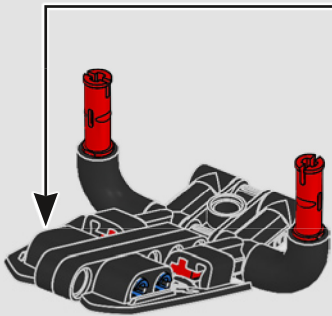
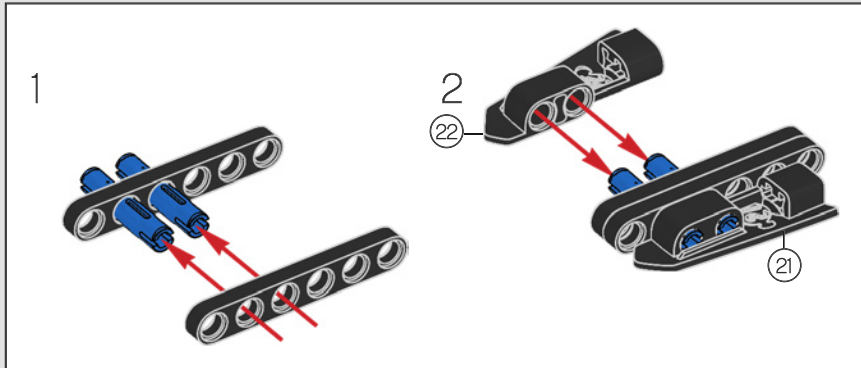
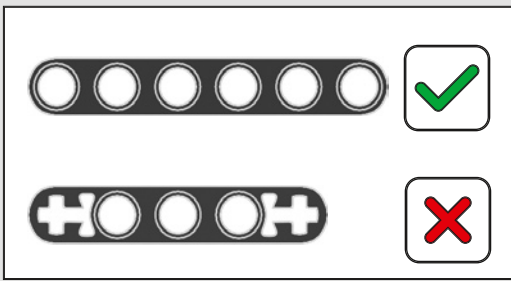

569

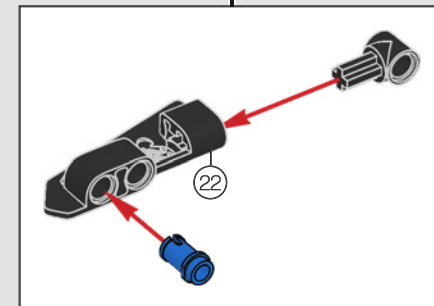
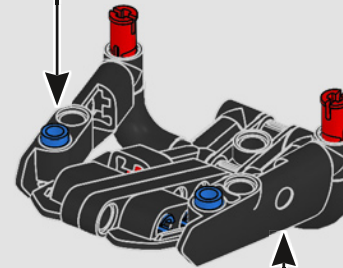
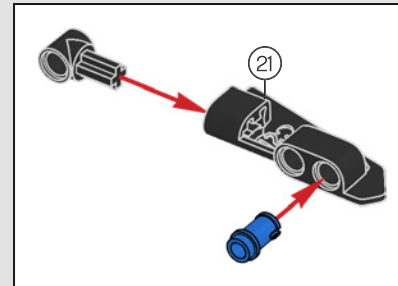

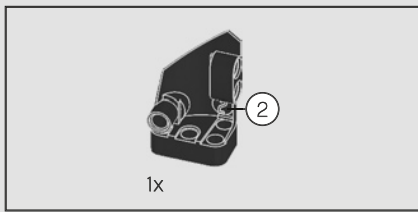

570

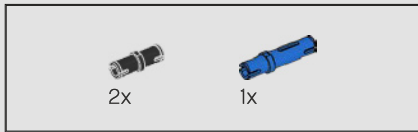
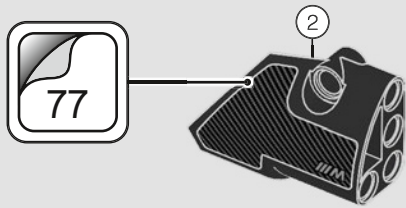

571

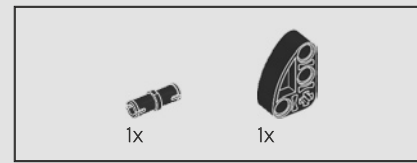
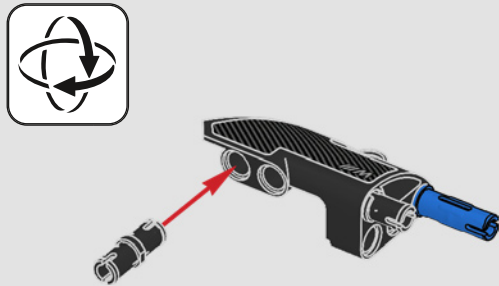

572

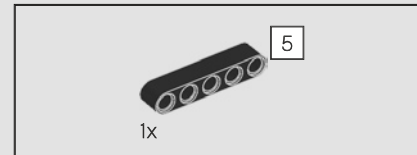
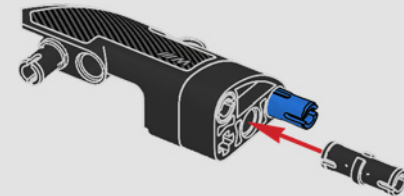

573

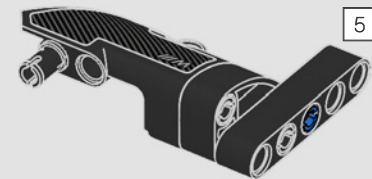

574

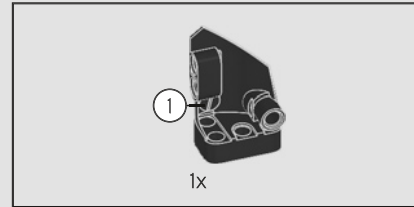
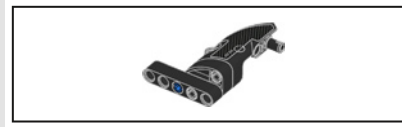
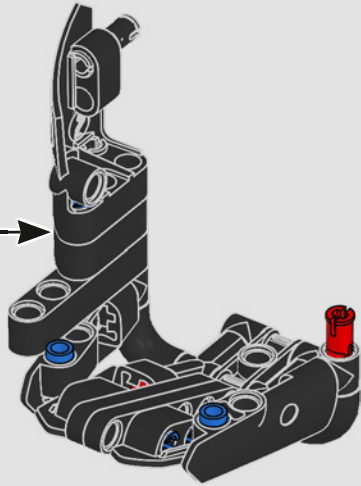

575

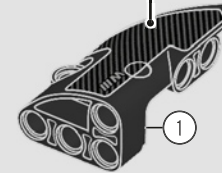

576

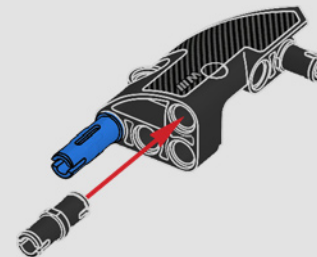

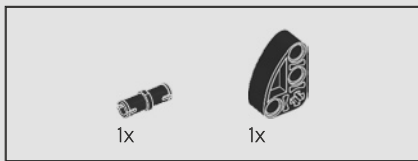

577

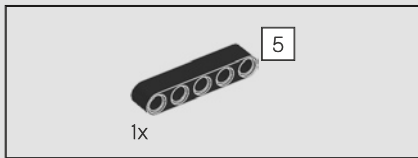
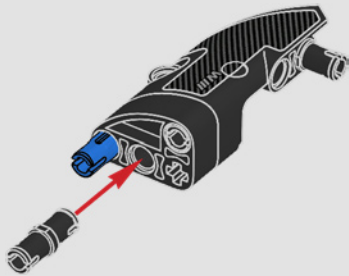

578

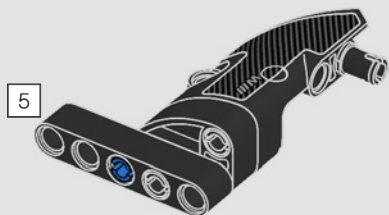

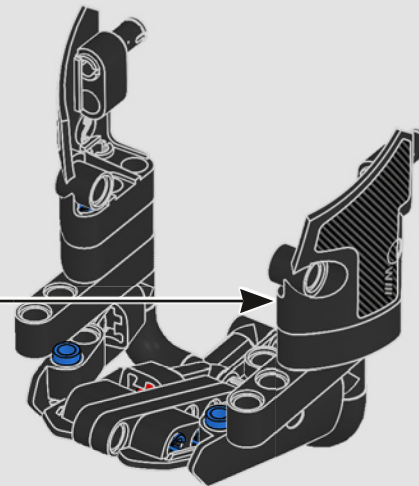

579

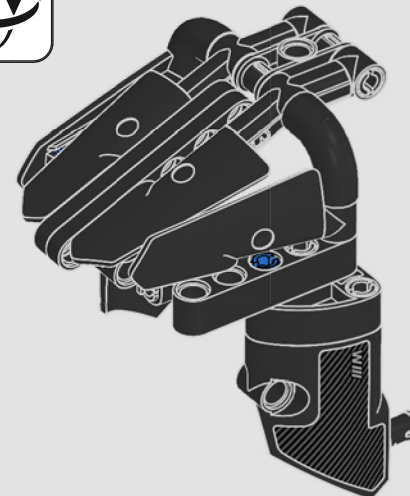
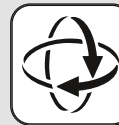

580

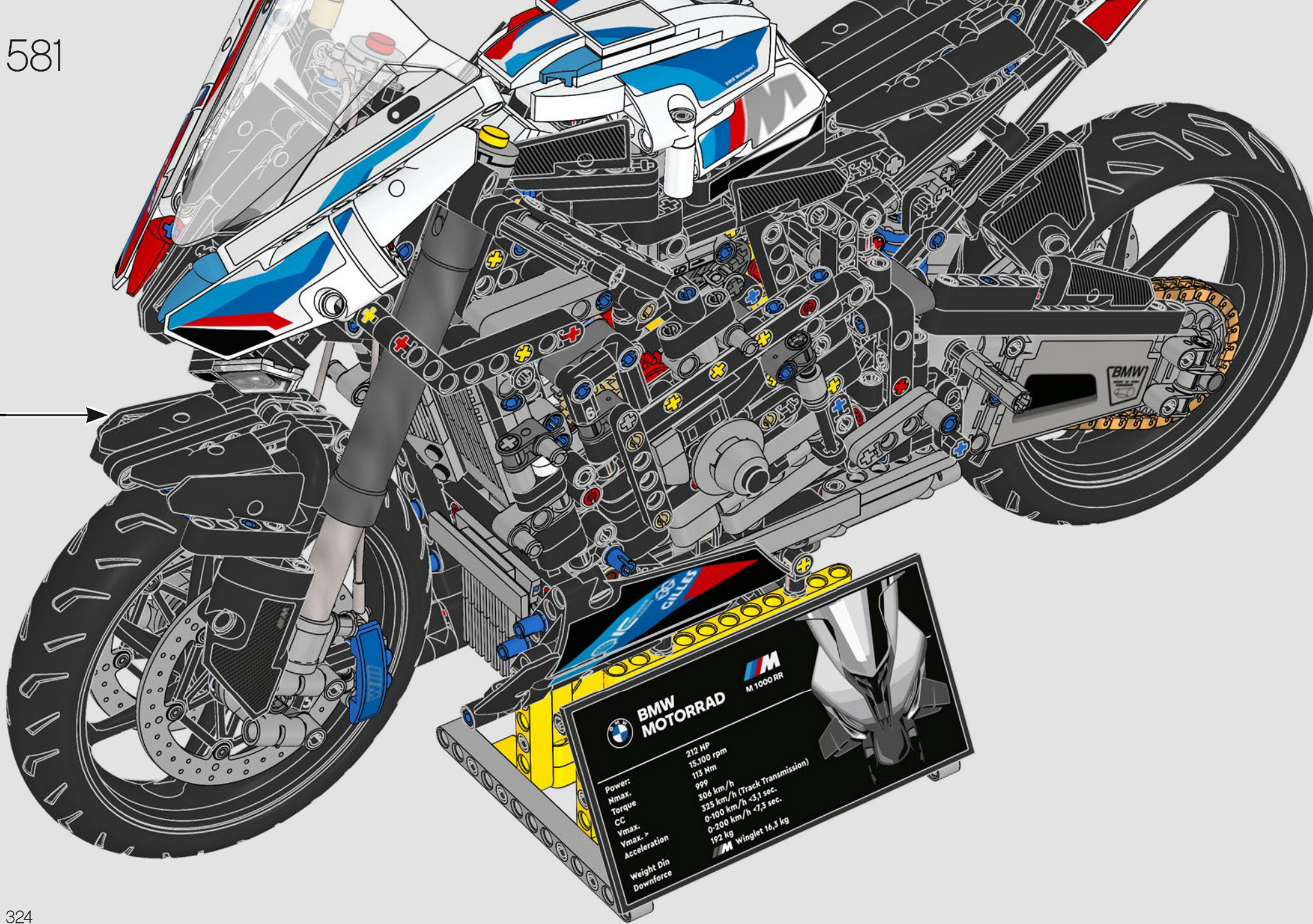



BMW MOTORRAD  **M 1000 RR**

Power:	212 HP
Nmax:	15,100 rpm
Torque:	118 Nm
CC:	999
Vmax:	306 km/h
Acceleration:	325 km/h (Track Transmission)
	0-100 km/h \approx 3,1 sec.
	0-200 km/h \approx 7,3 sec.
Weight Din	192 kg
Downforce	 Winglet 16,3 kg

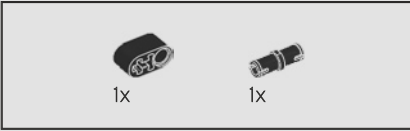
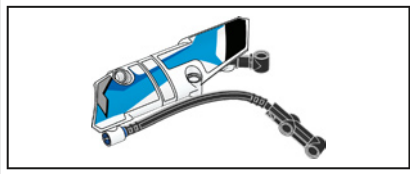

582

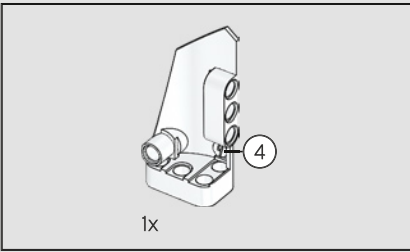
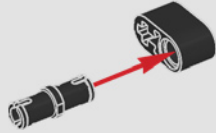

583

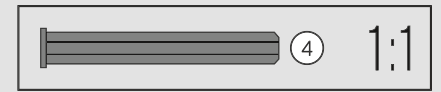
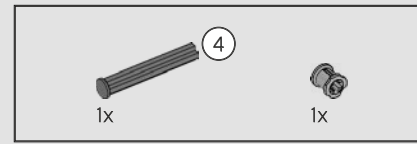
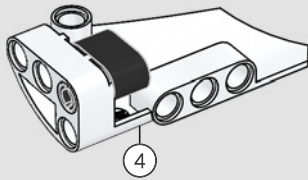

584

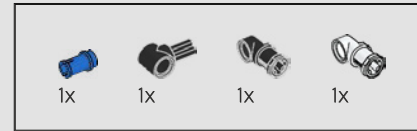
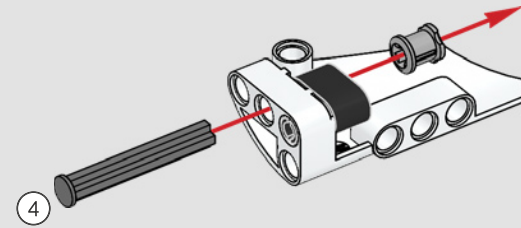

585

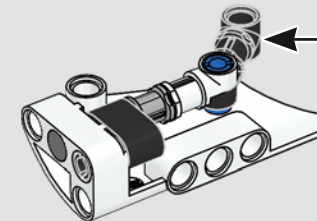
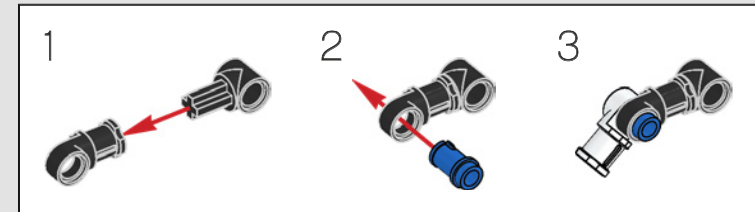

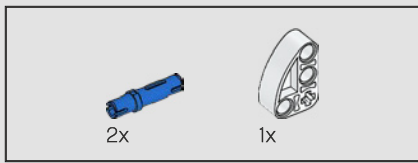

586

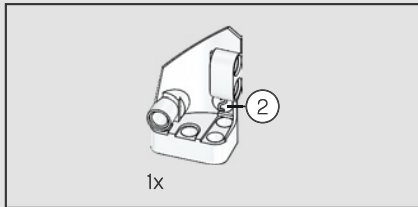
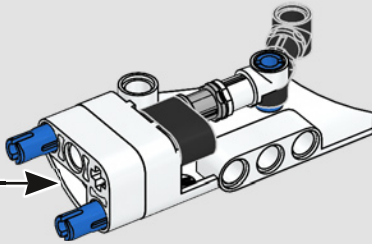
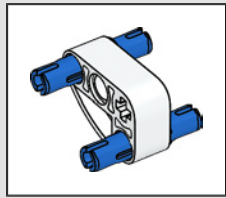

587

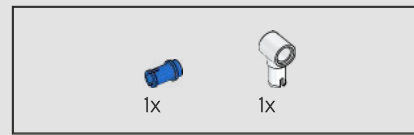
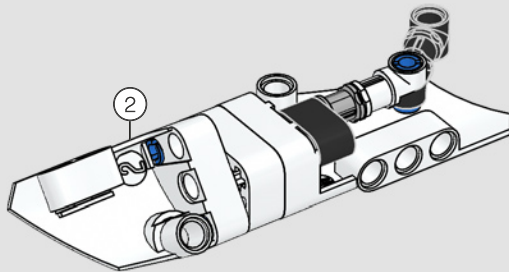

588

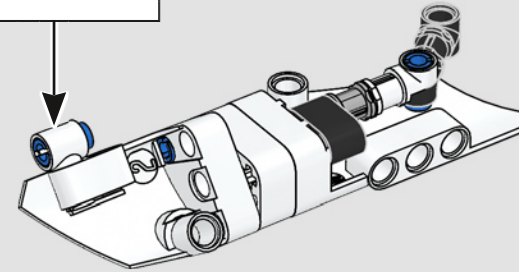
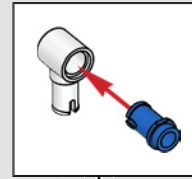

589

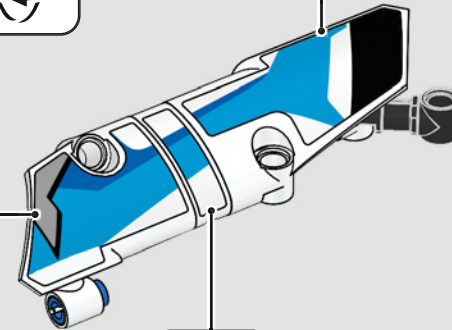

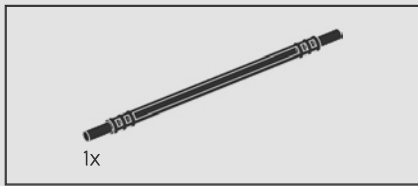

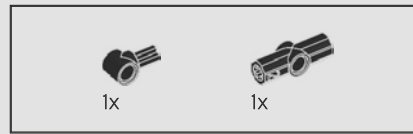
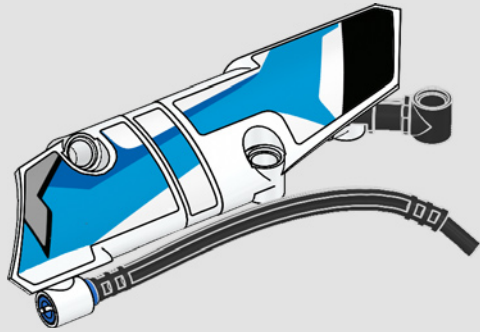

590

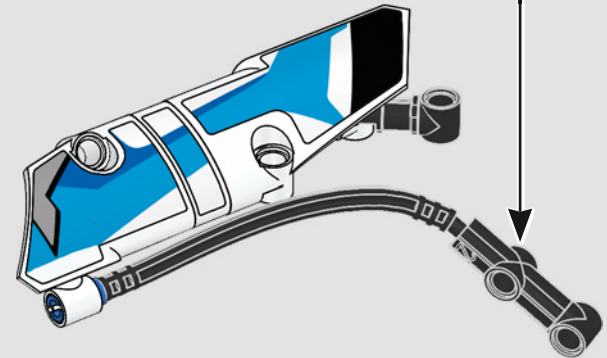
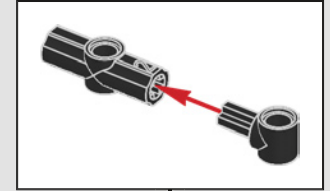

591

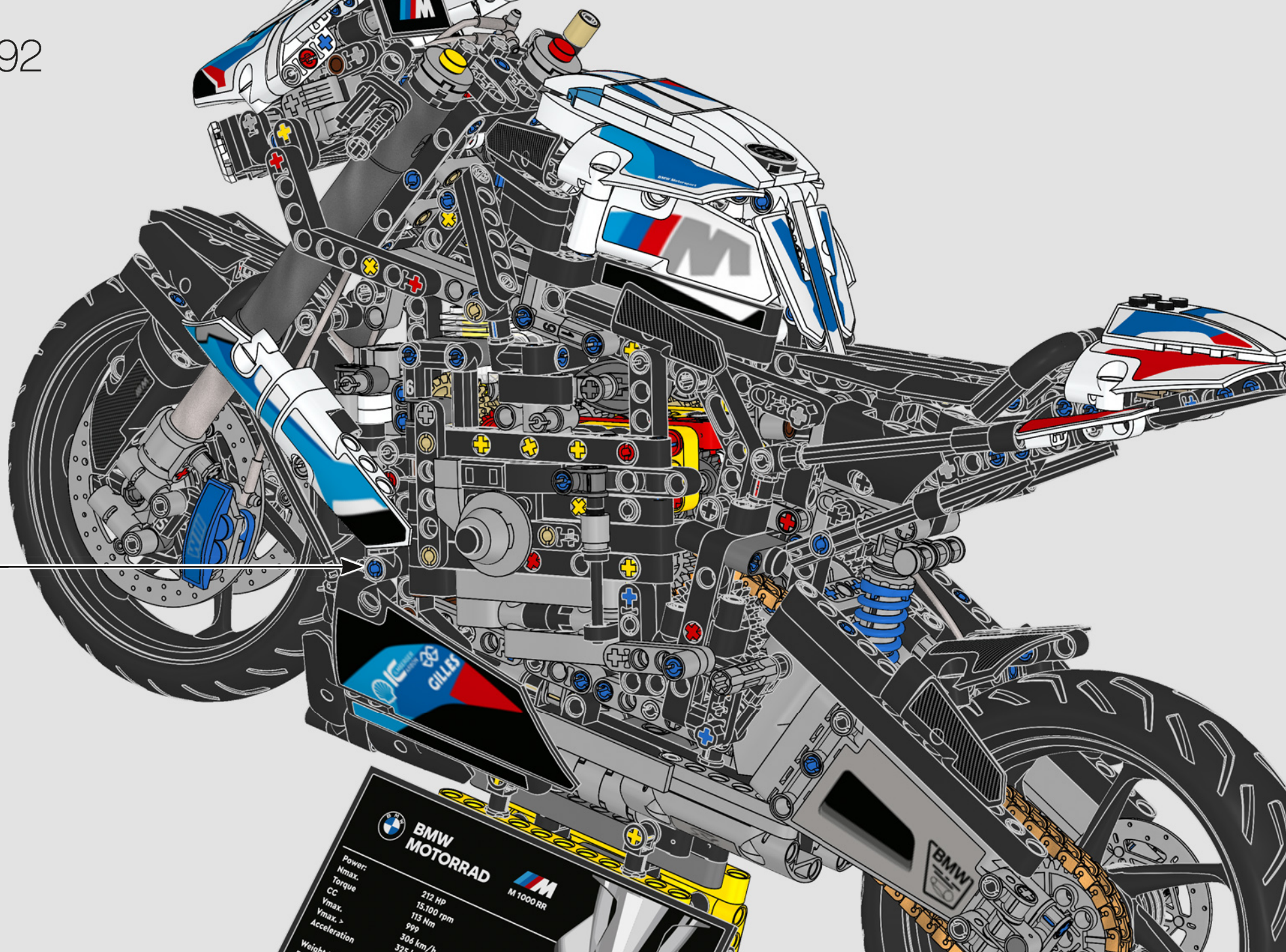



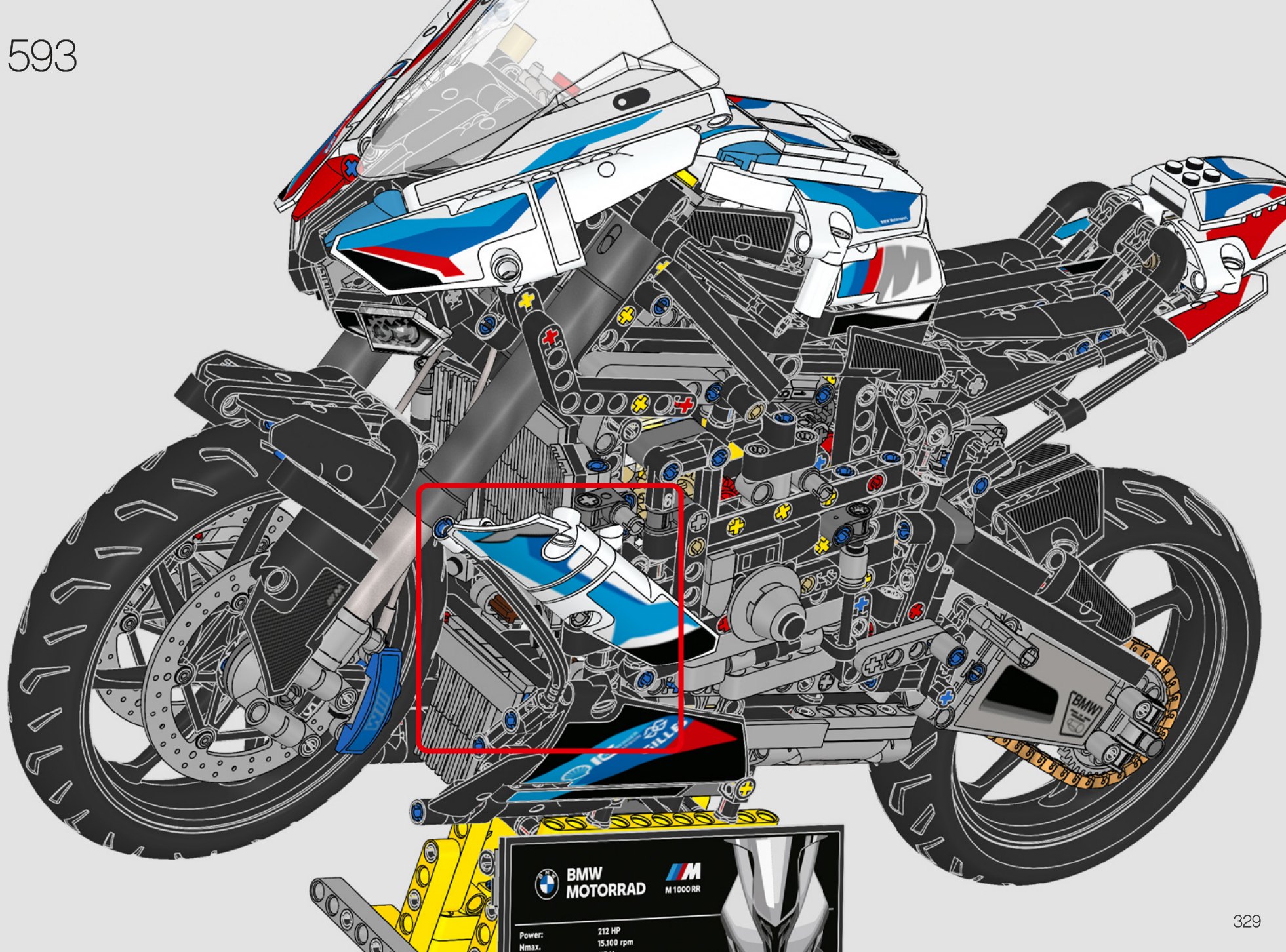

BMW MOTORRAD  **M 1000 RR**

Power:	212 HP
Mmax:	15,100 rpm
Torque	113 Nm
CC	999
Vmax:	306 km/h
Vmax >	328 km/h
Acceleration	
Weight	



 **BMW**
MOTORRAD  **M 1000 RR**

Power: 212 HP
Nmax. 15.100 rpm

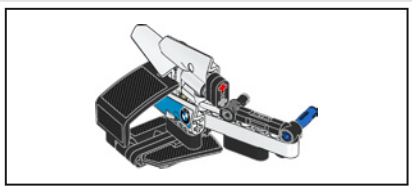

594

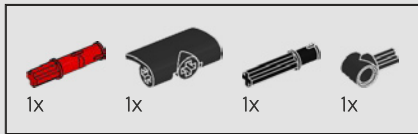
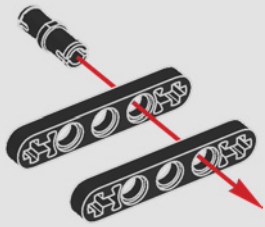

595

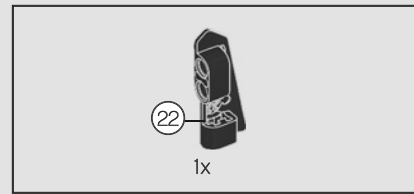
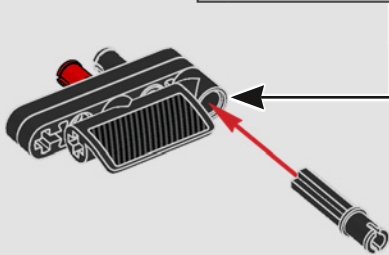
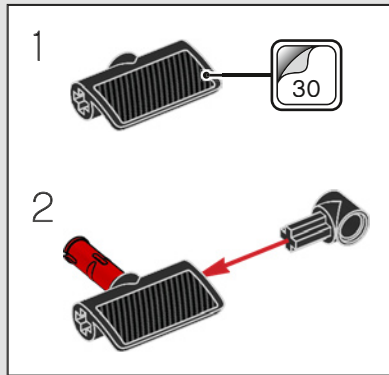

596

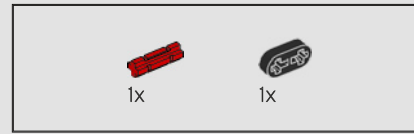
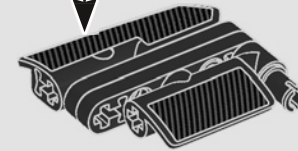
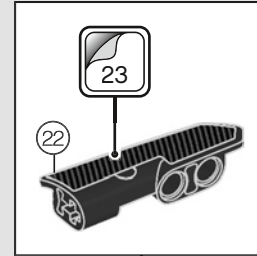

597

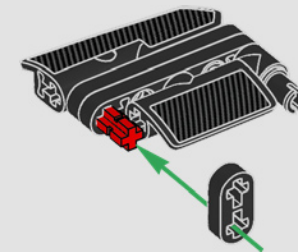

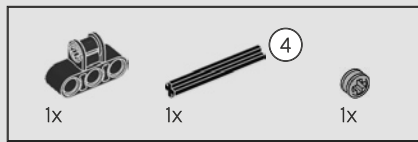

598

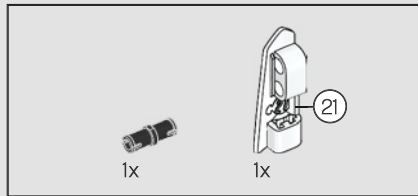
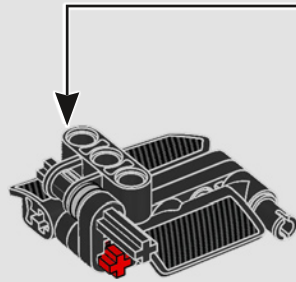
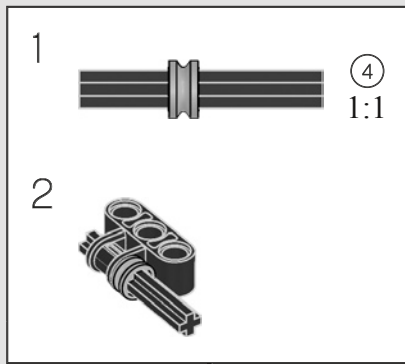

599

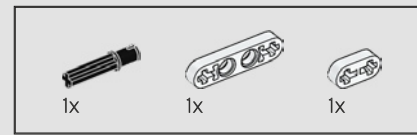
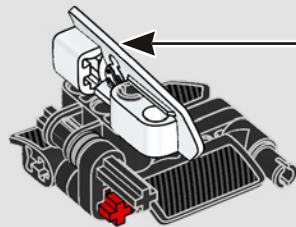
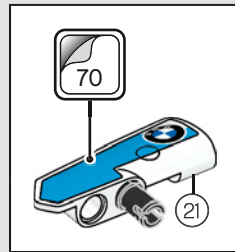

600

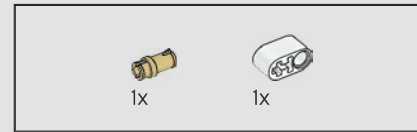
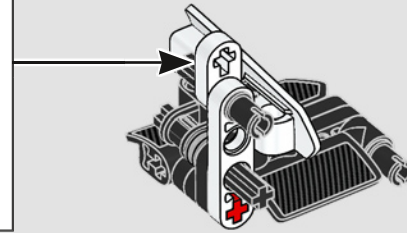
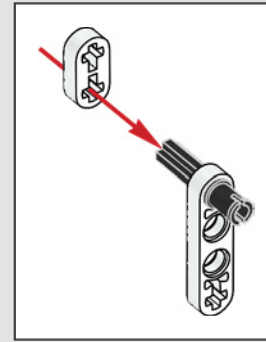

601

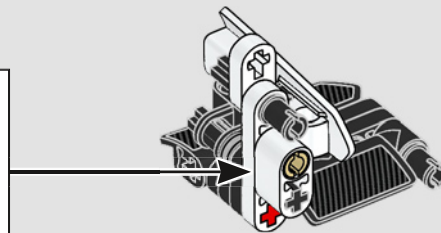
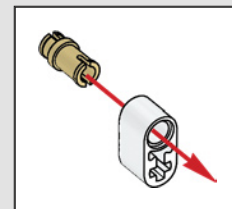

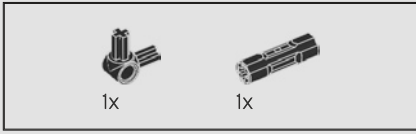
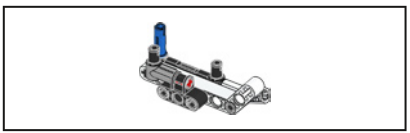

602

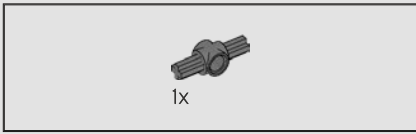
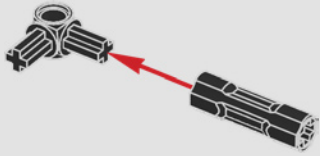

603

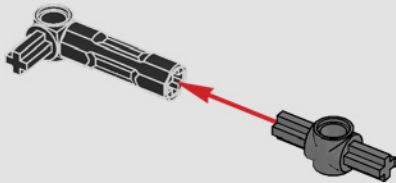

604

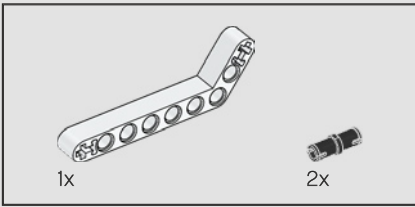
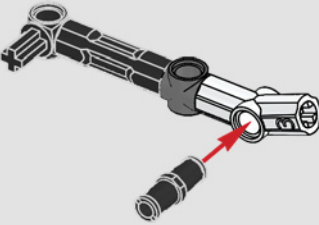

605

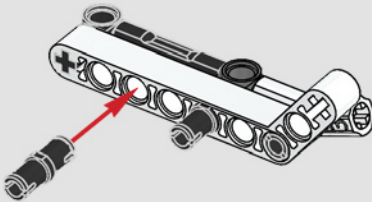

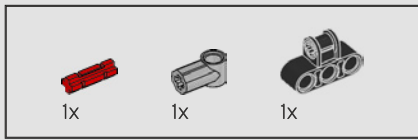

606

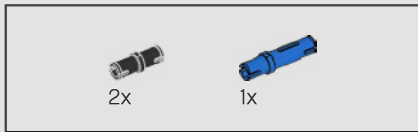
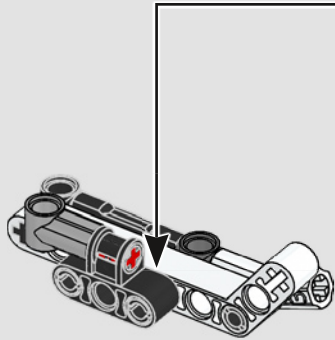
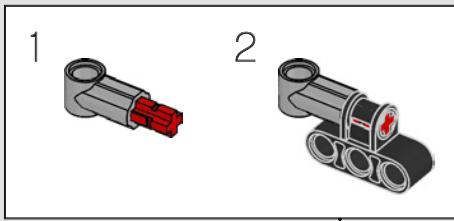

607

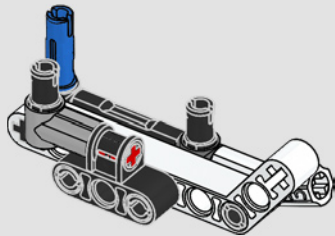

608

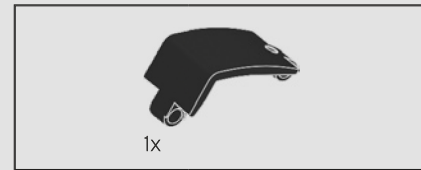
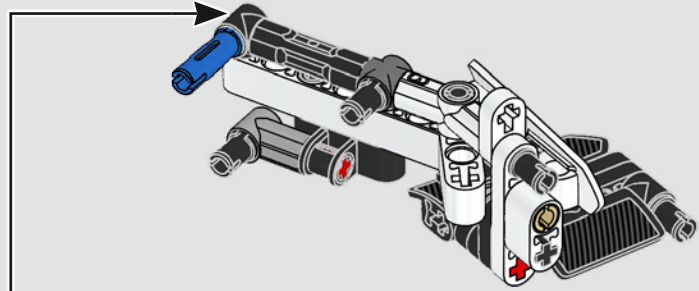

609

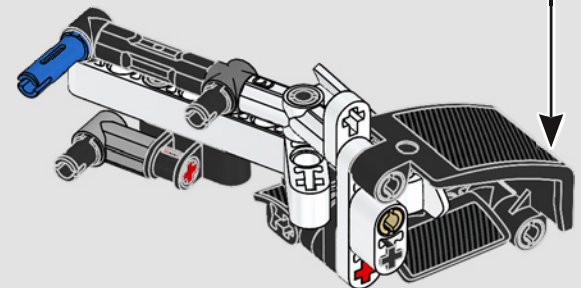
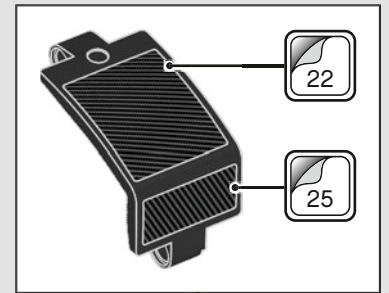

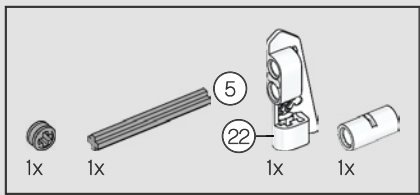

610

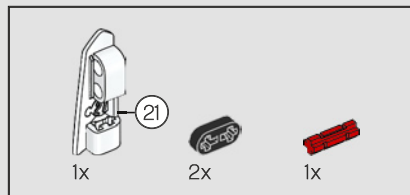
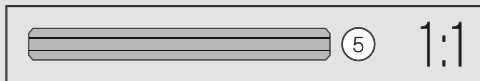
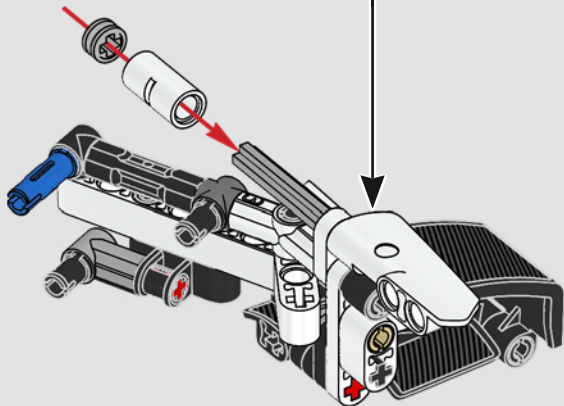
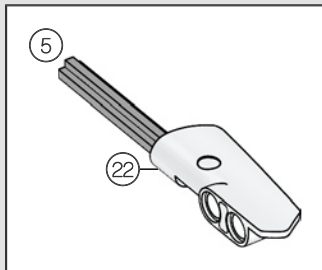

611

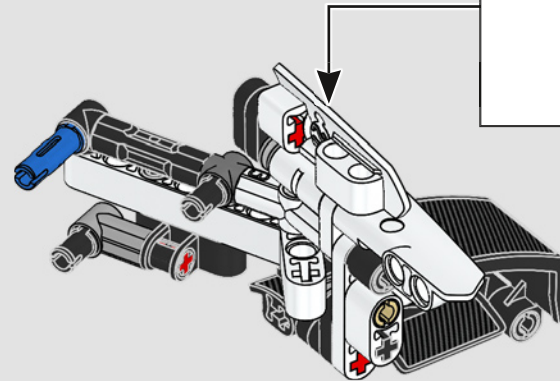
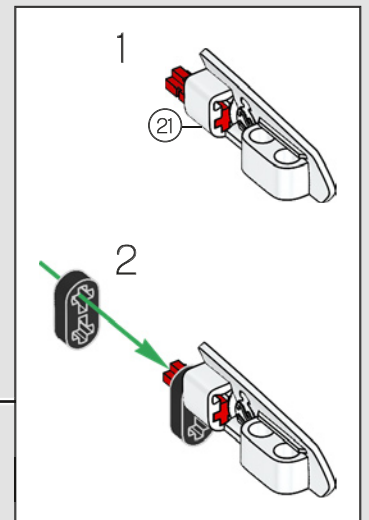

612

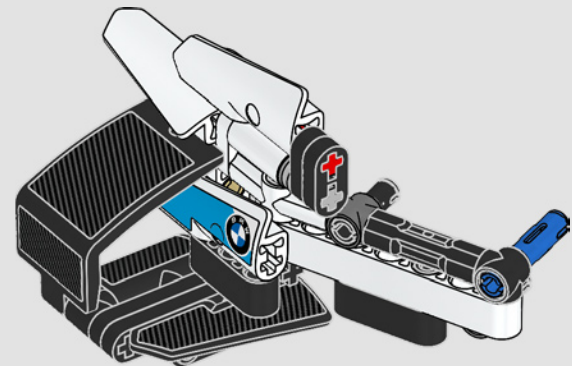

613

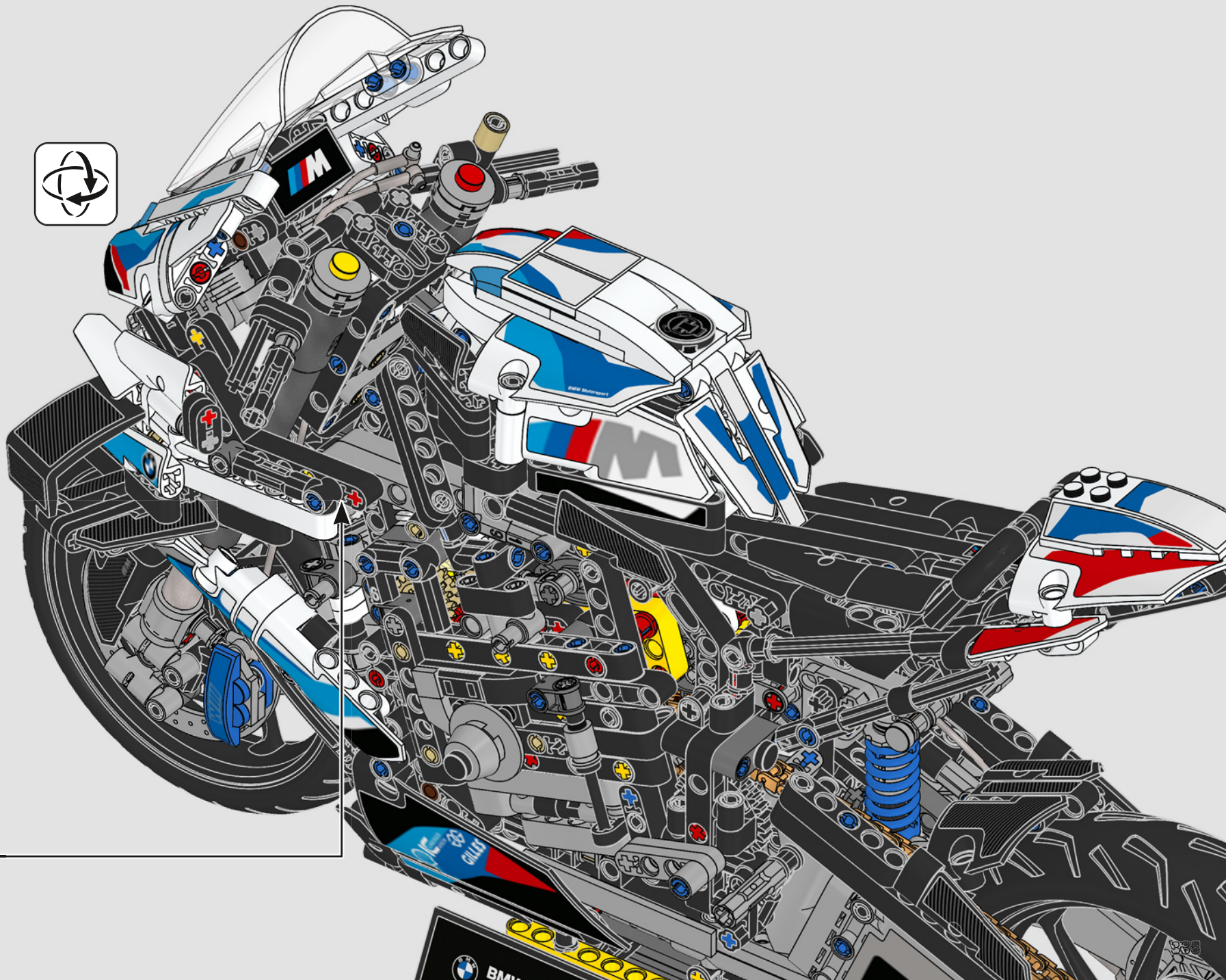

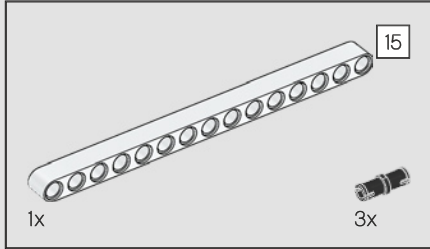
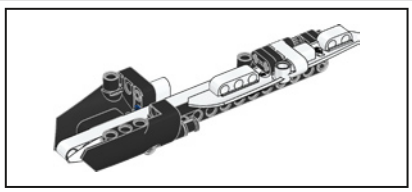

614

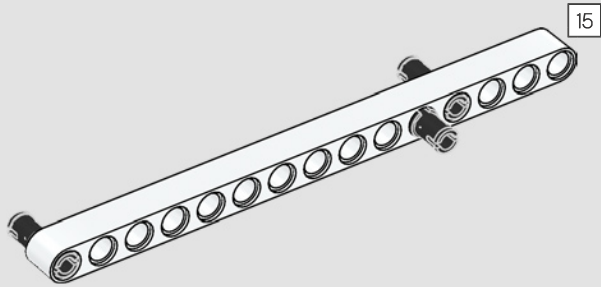

615

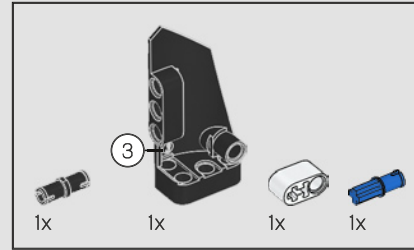
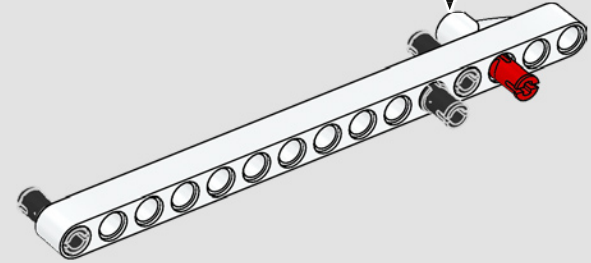
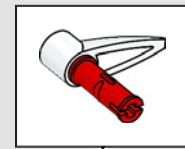

616

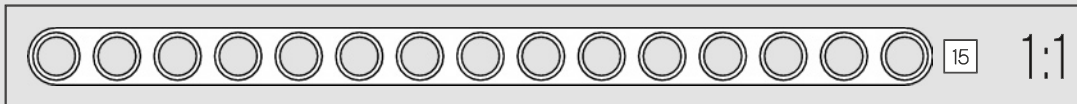
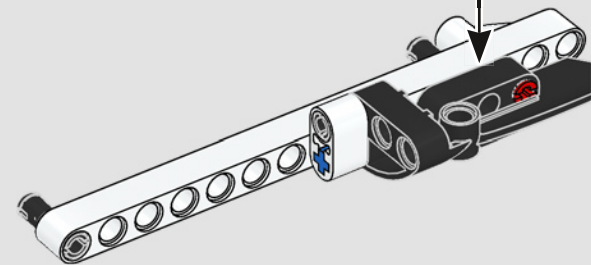
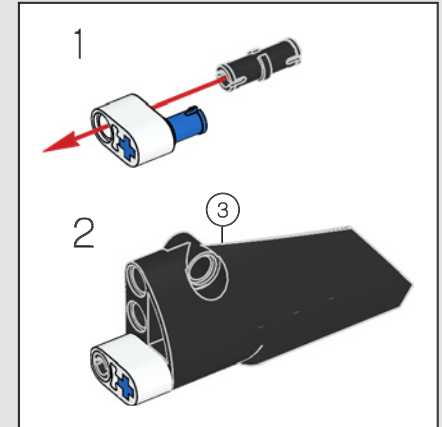

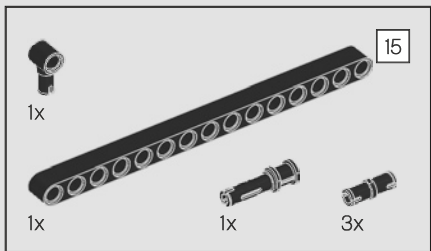

617

1

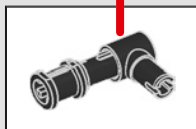
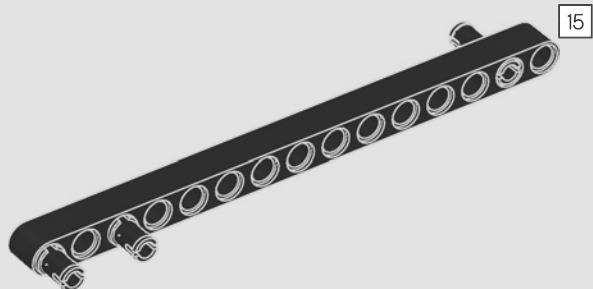

2

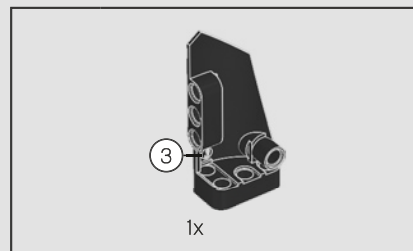
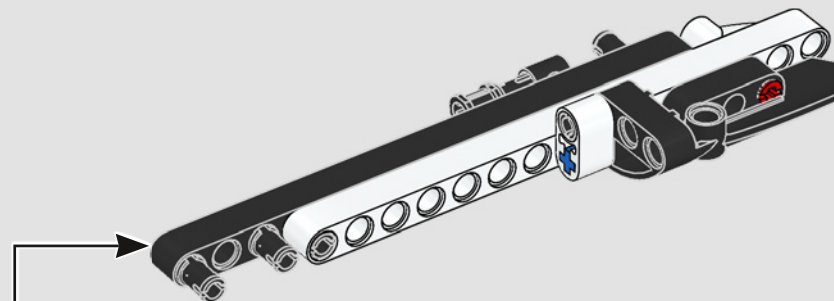
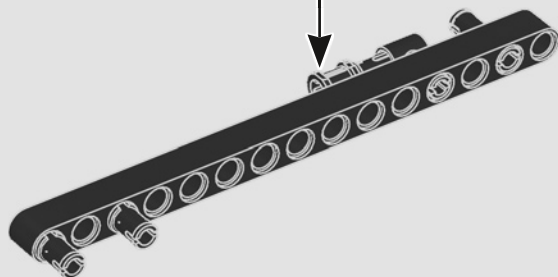

618

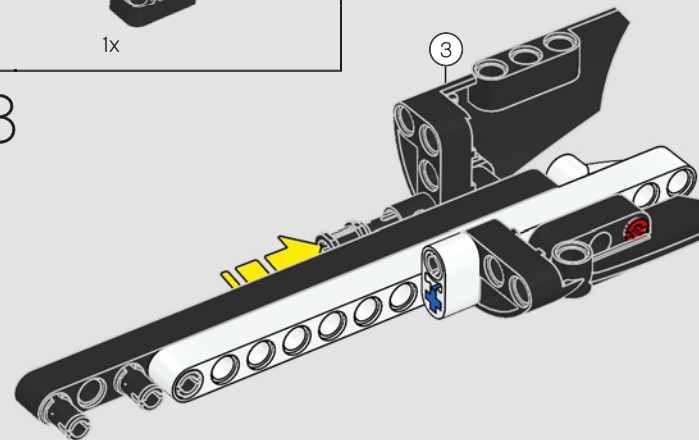

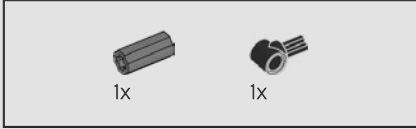
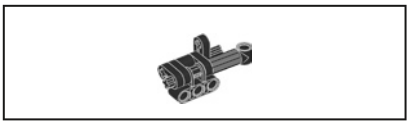

619

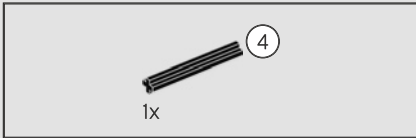
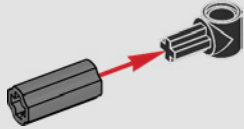

620

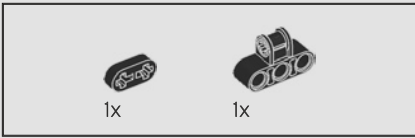
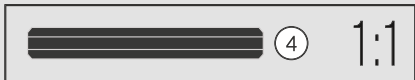
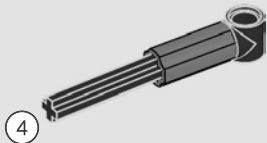

621

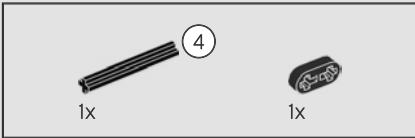
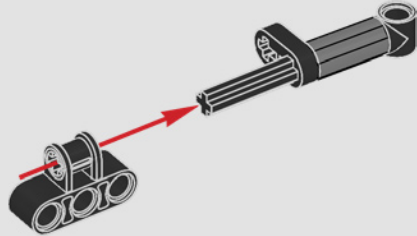

622

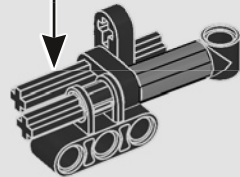



623

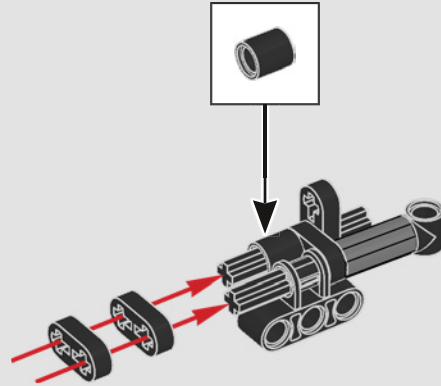

624

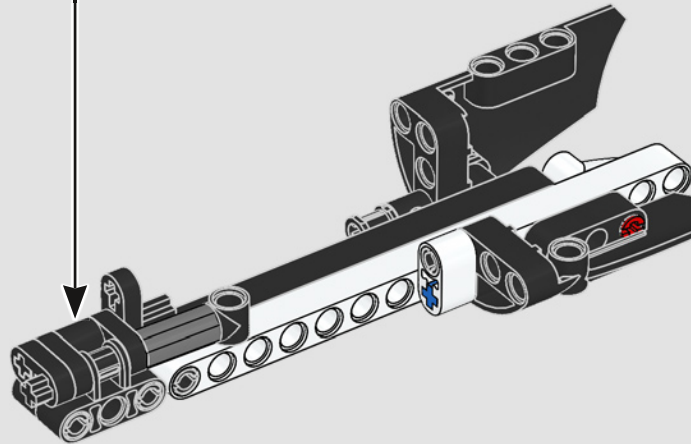

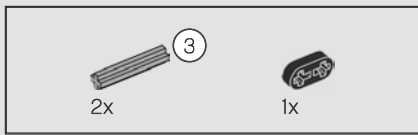

625

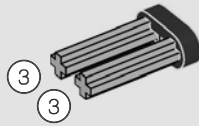
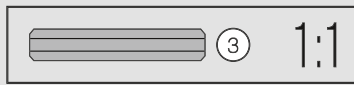

626

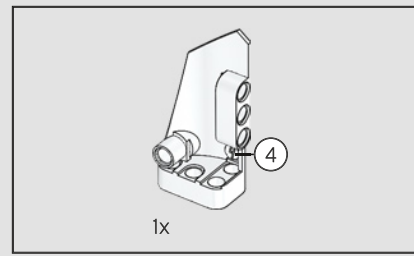
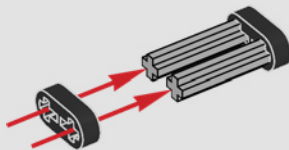

627

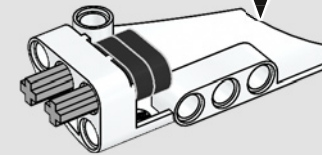
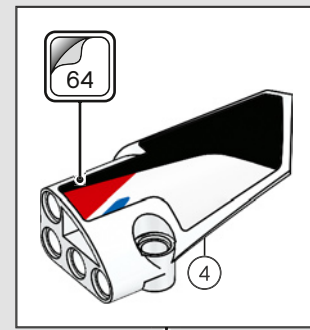

628

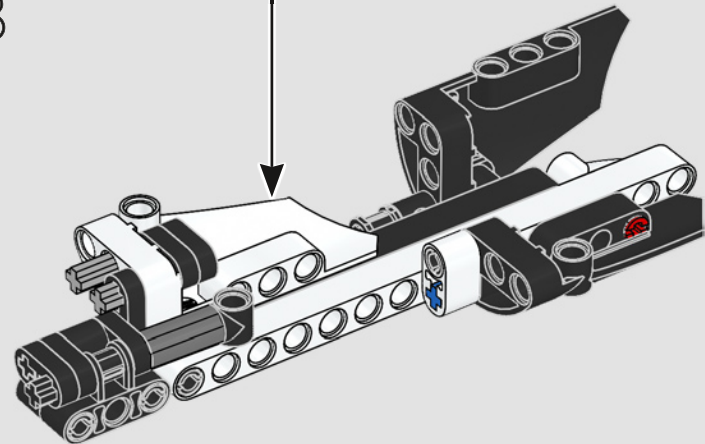

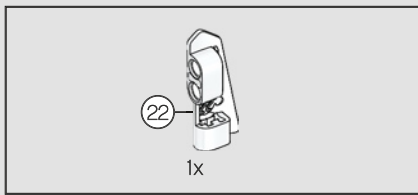

629

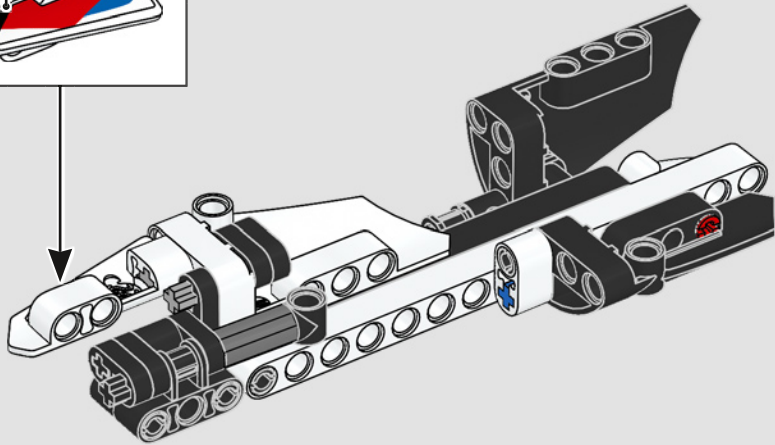
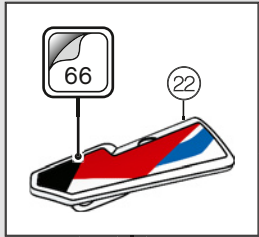

630

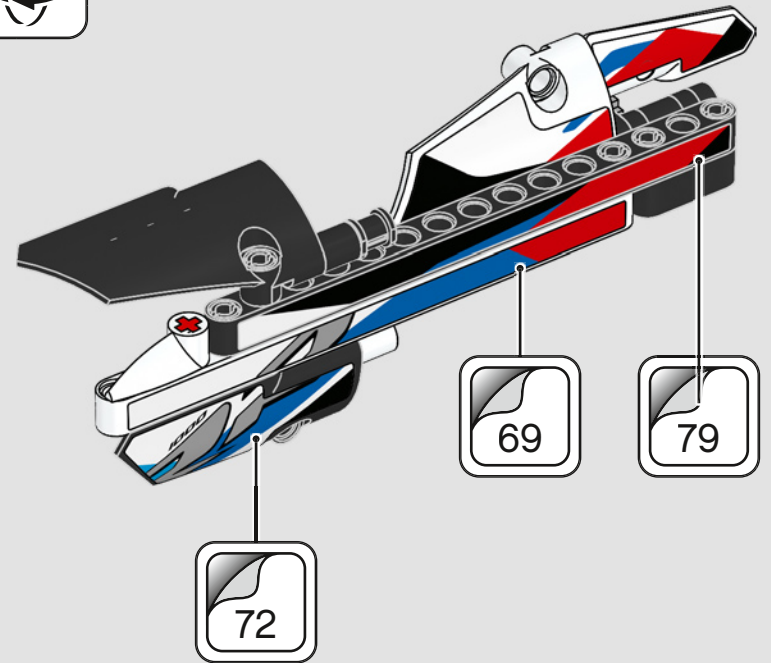

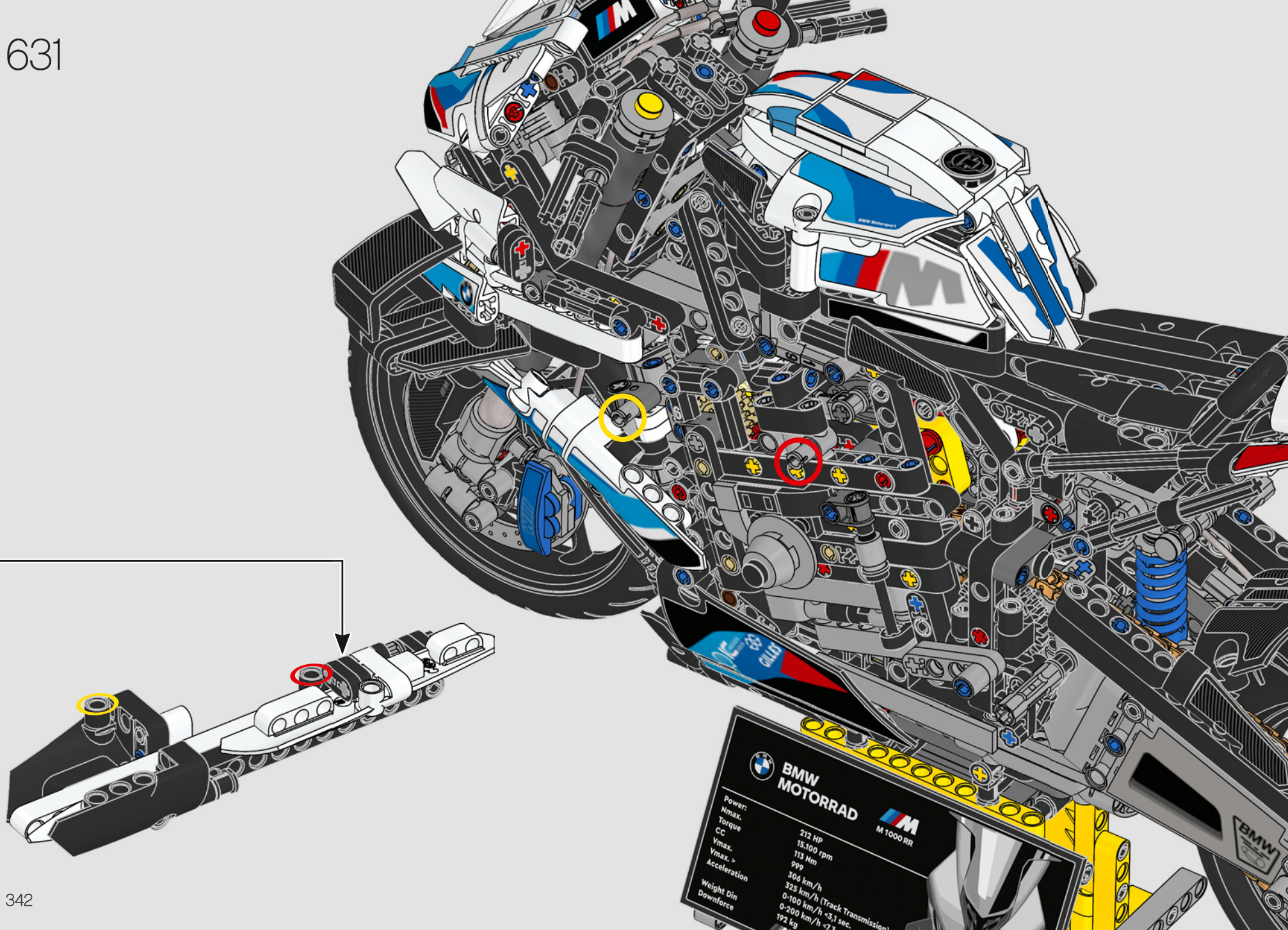

BMW MOTORRAD		M 1000 RR
Power:	212 hp	
Nmax:	15,100 rpm	
Torque	113 Nm	
CC	999	
Vmax:	306 km/h	
Vmax, >	325 km/h (Track Transmission)	
Acceleration	0-100 km/h < 3,1 sec.	
Weight Din	192 kg	
Downforce	0-200 km/h < 7,3 sec.	

632

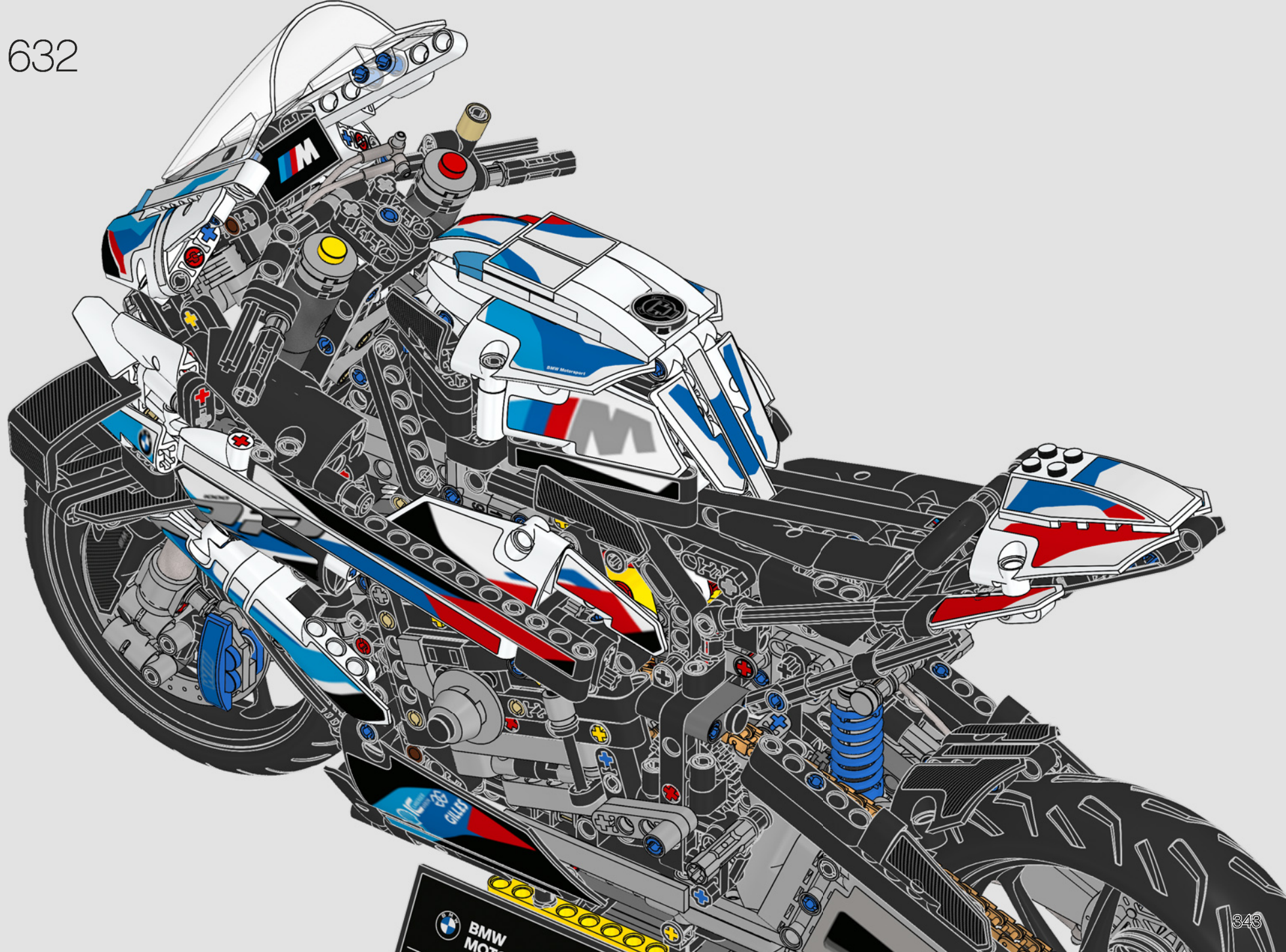

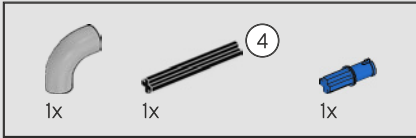
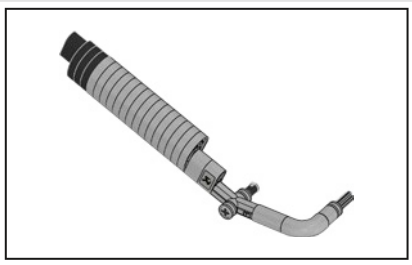

633

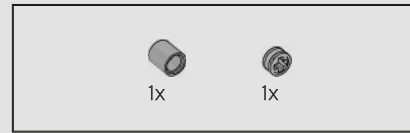
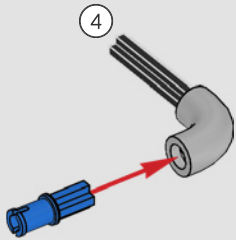

634

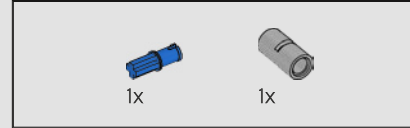
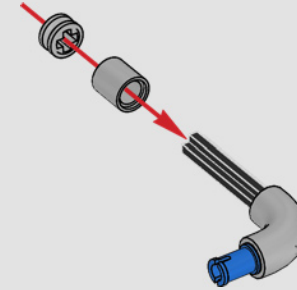

635

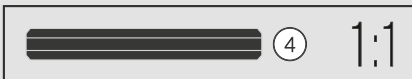
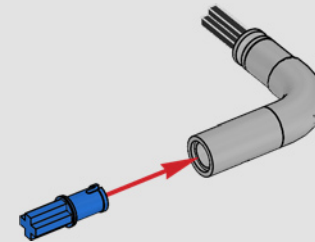

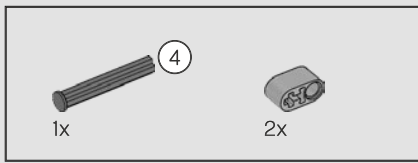

636

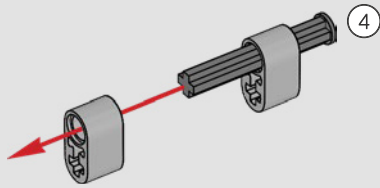

637

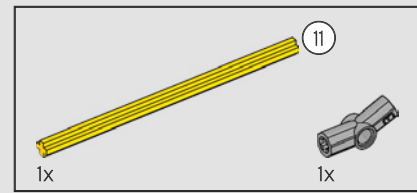
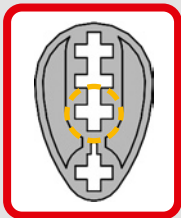
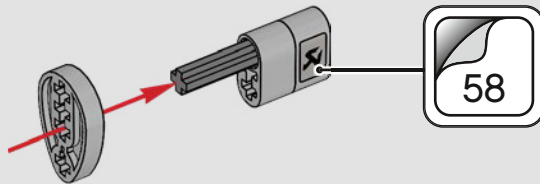

638

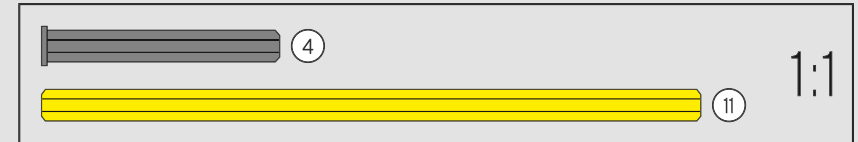
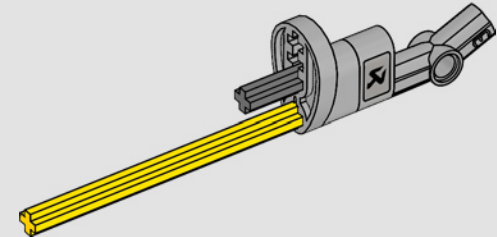
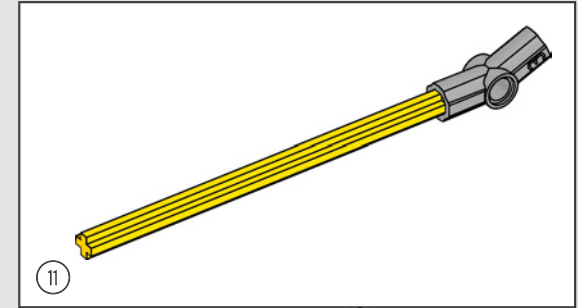



4x

639

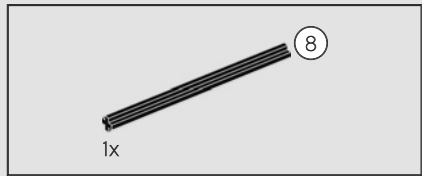
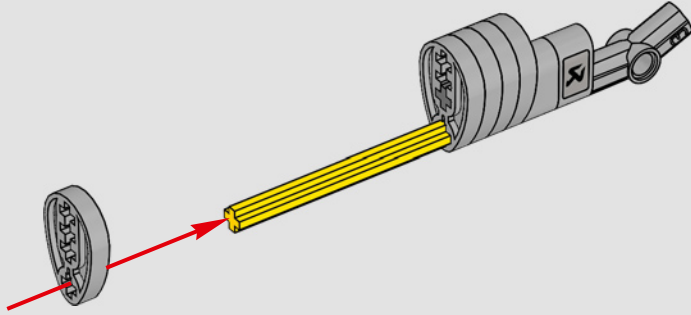

1x

640

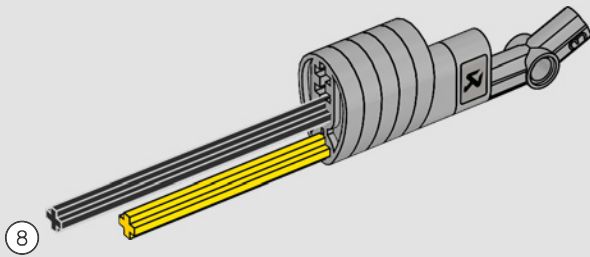

10x

641

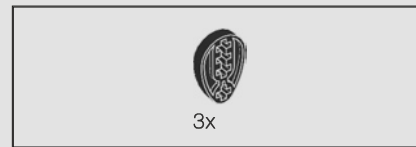
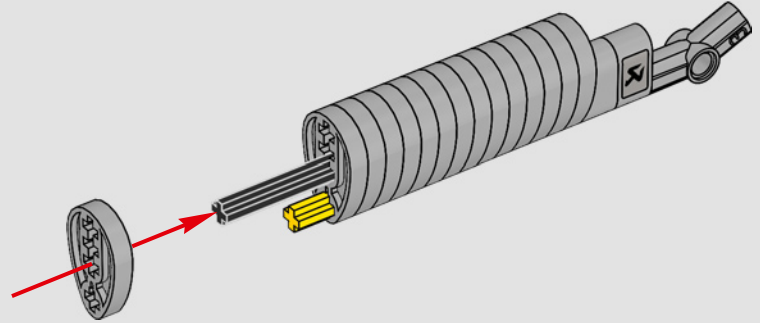

3x

642

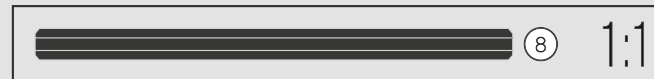
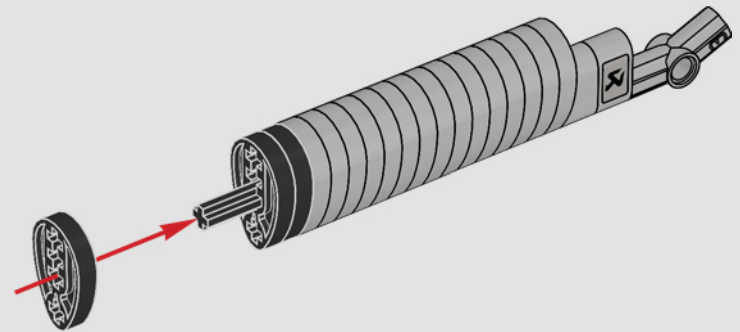

8

1:1

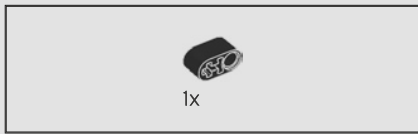

643

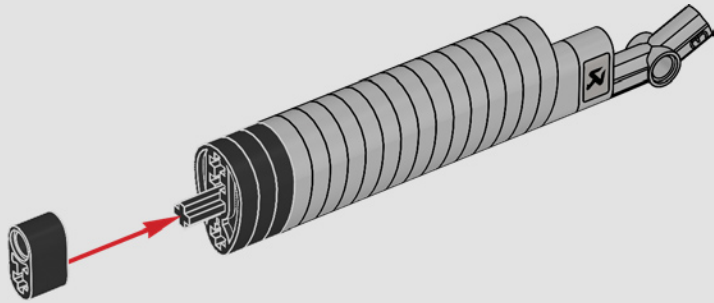

644

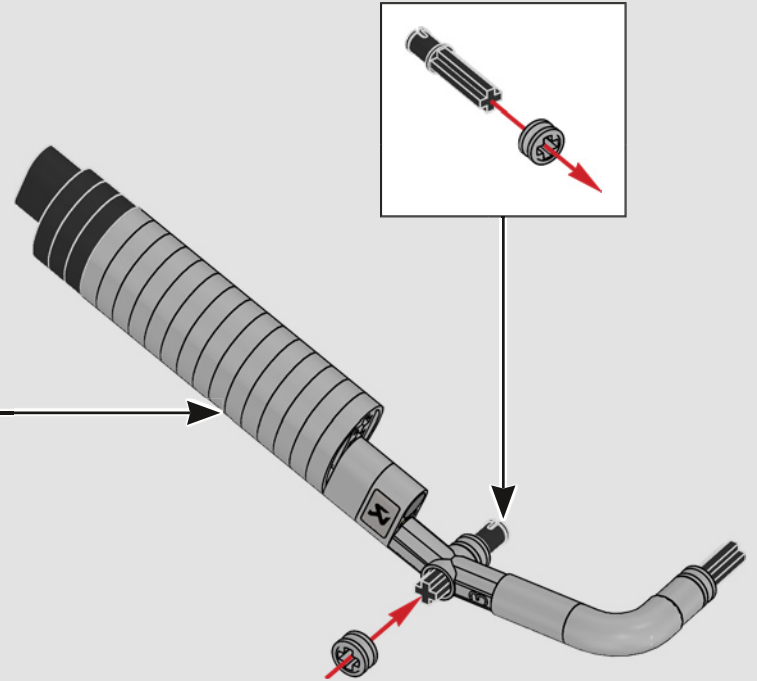

645

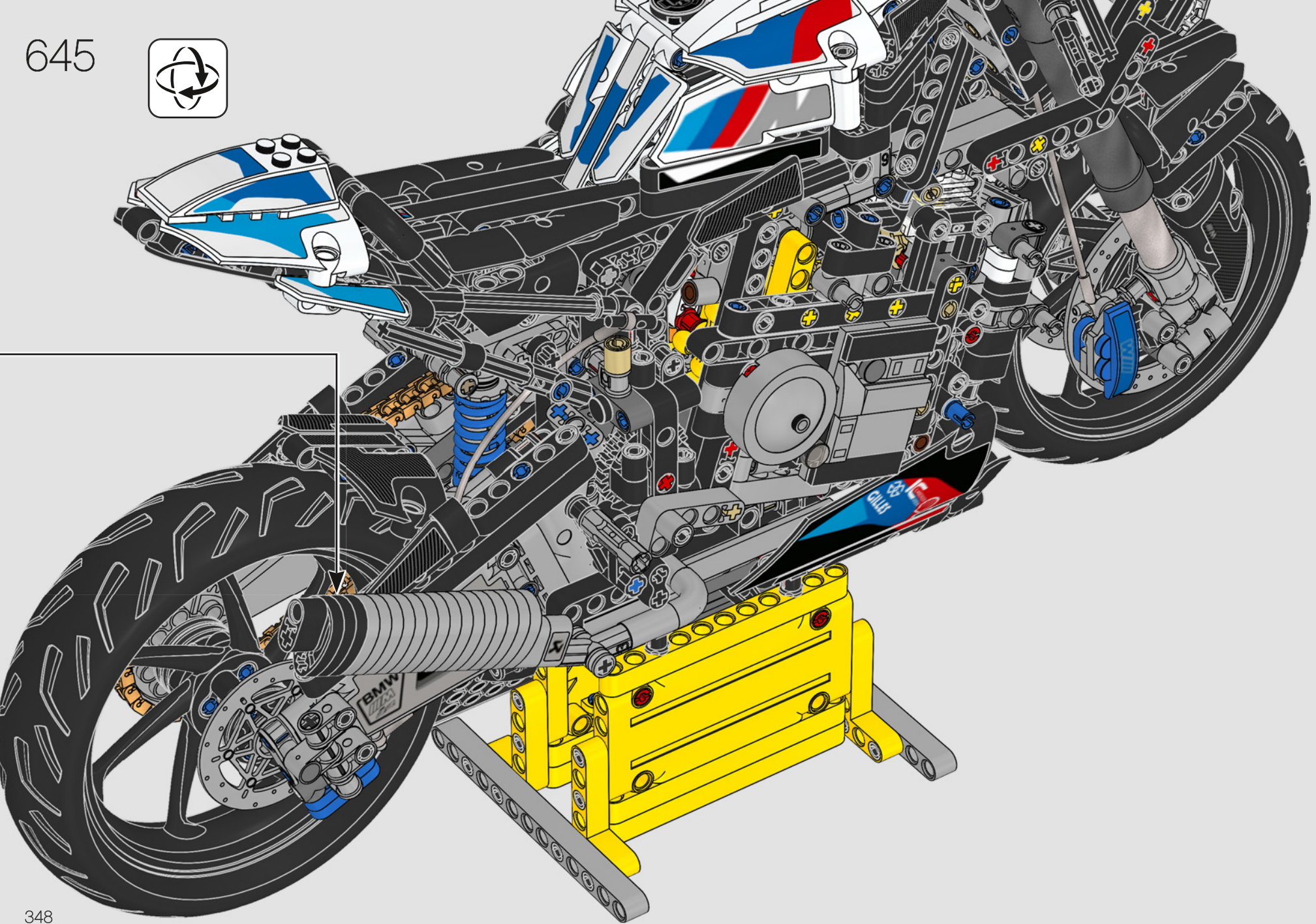

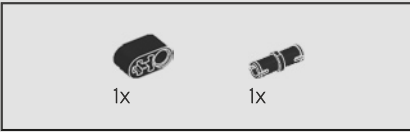
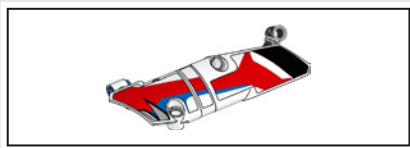

646

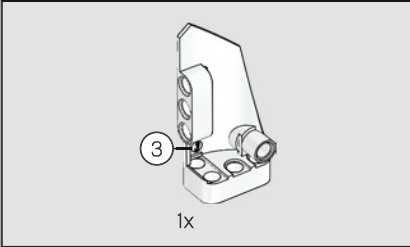
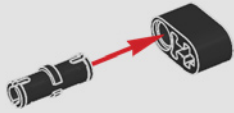

647

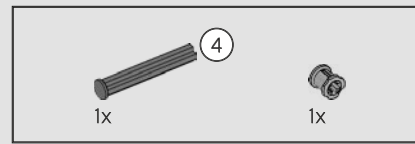
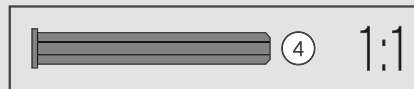
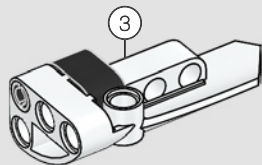

648

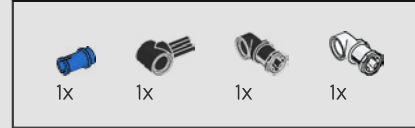
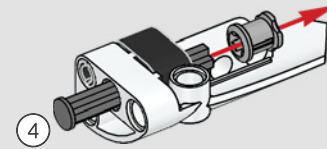

649

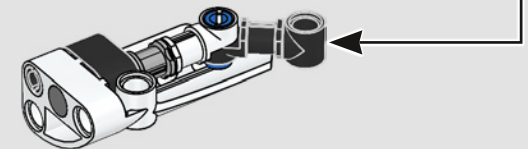
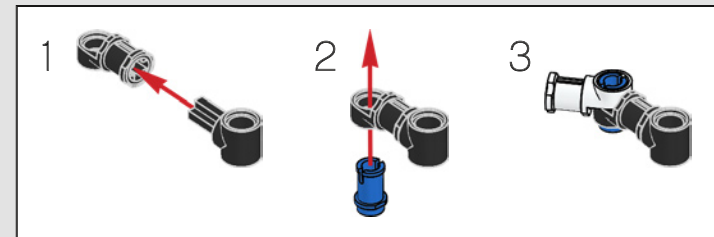

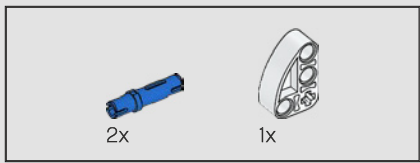

650

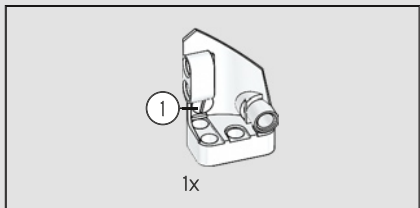
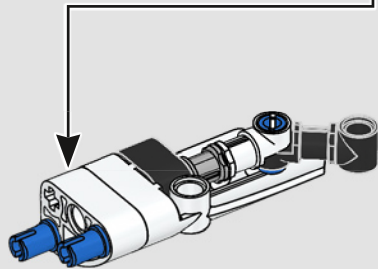
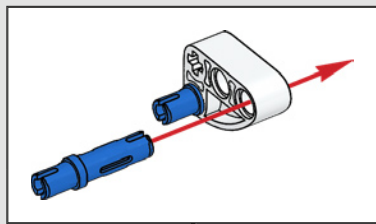

651

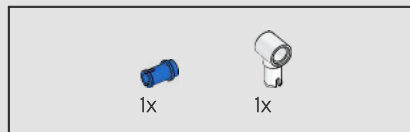
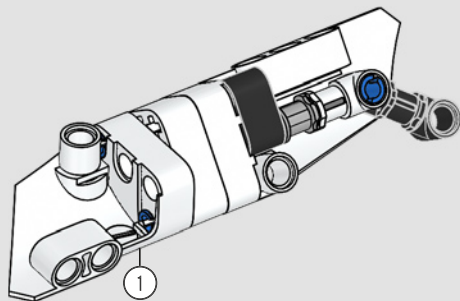

652

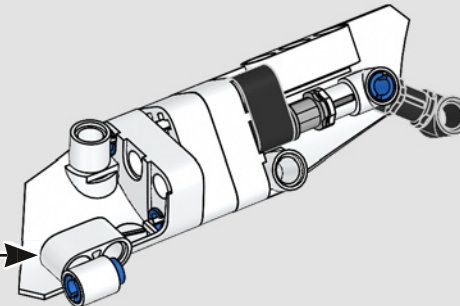
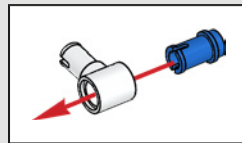

653

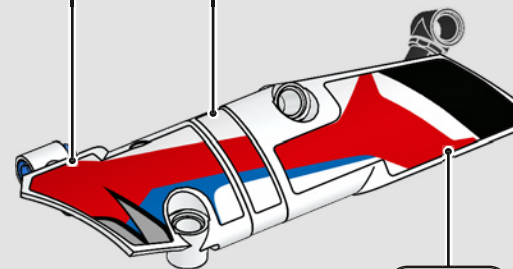
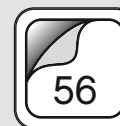

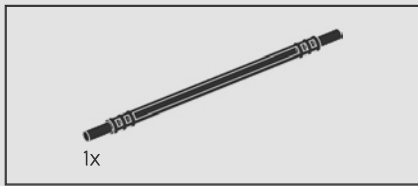

654

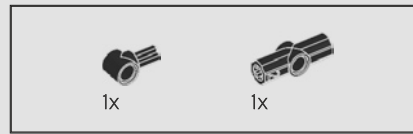
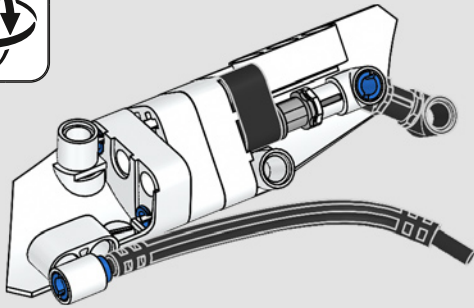

655

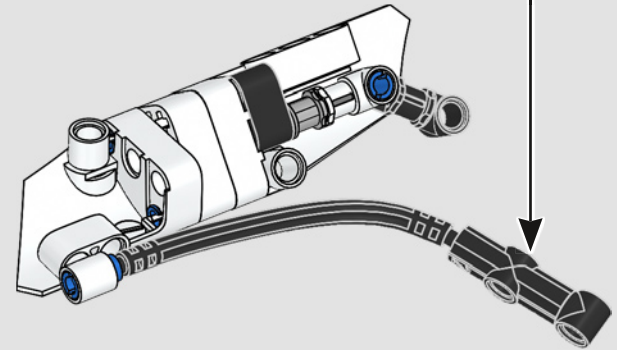
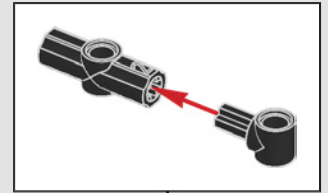

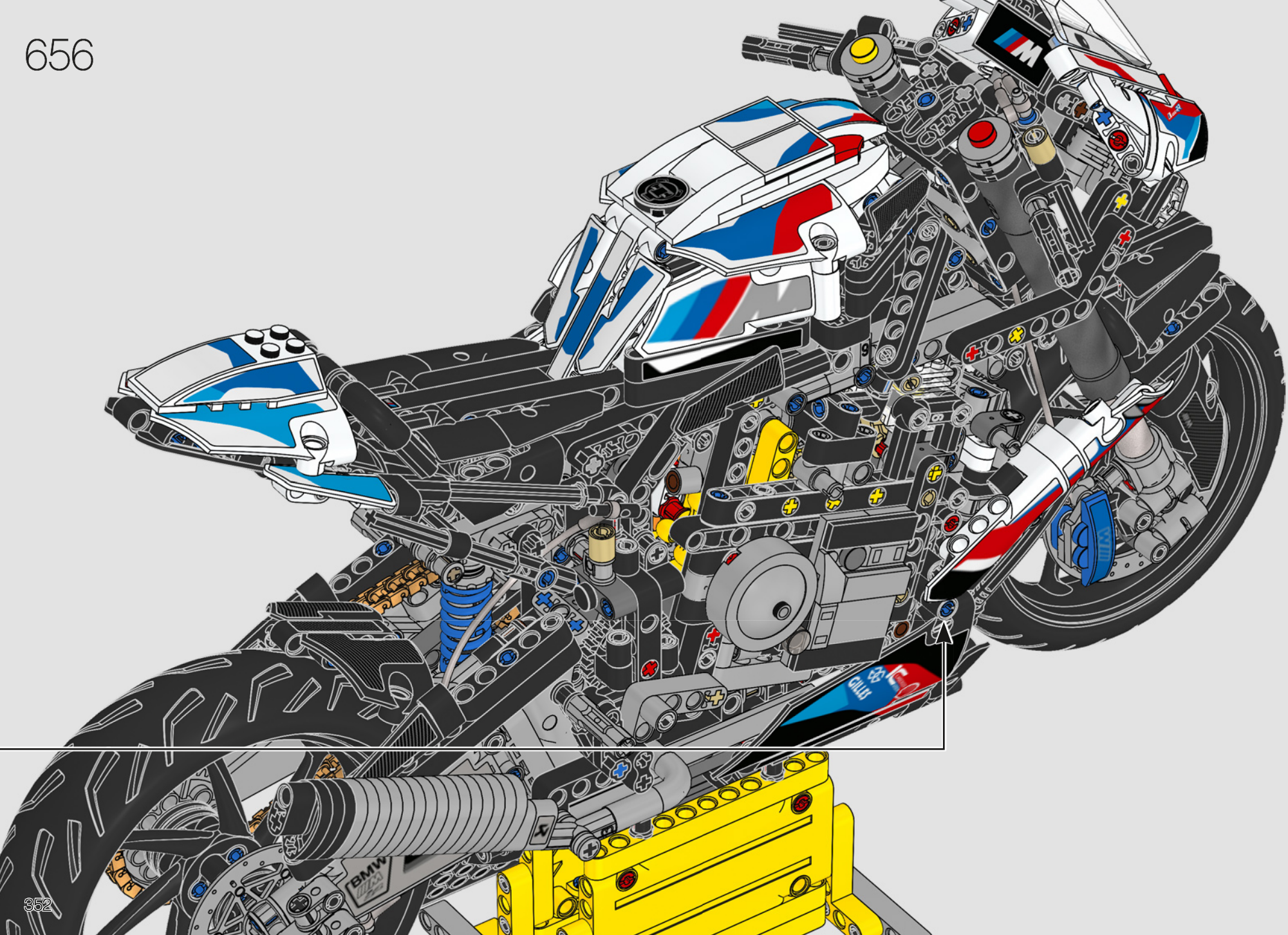

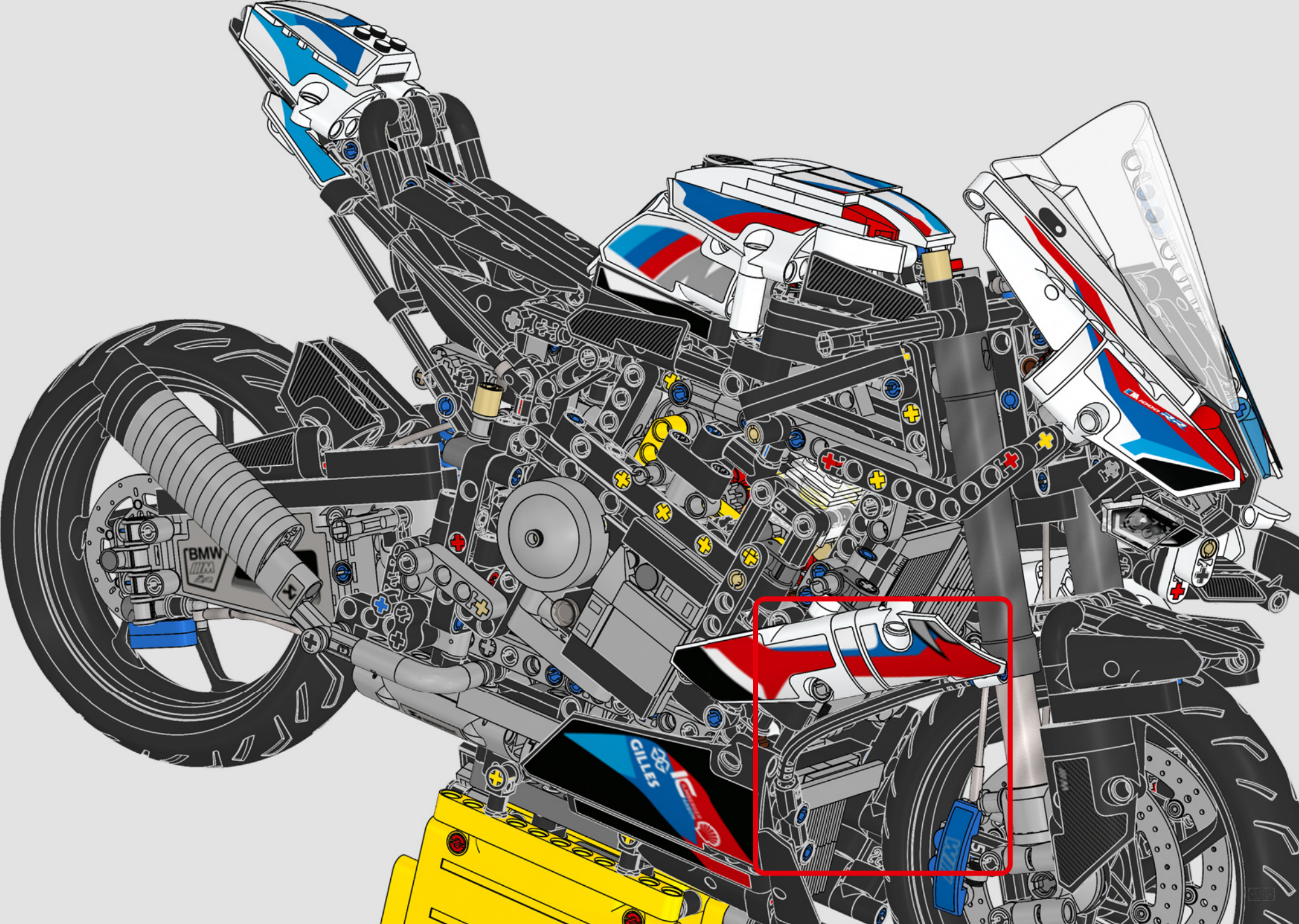

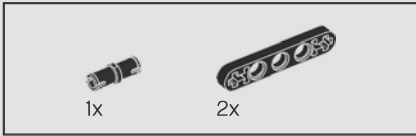
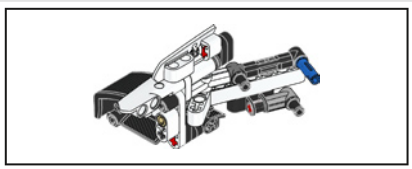

657

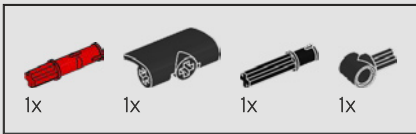
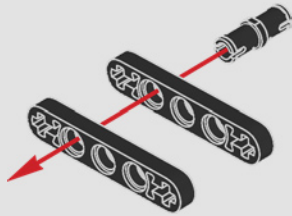

658

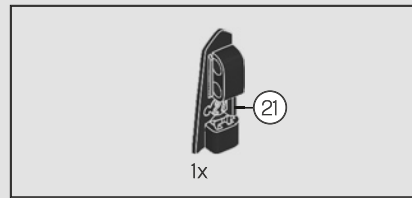
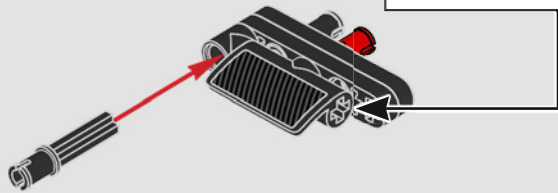
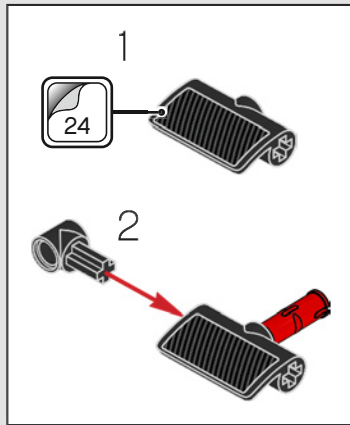

659

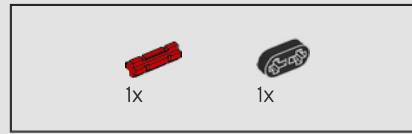
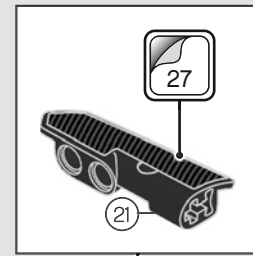

660

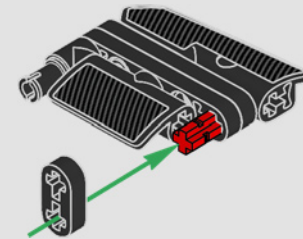

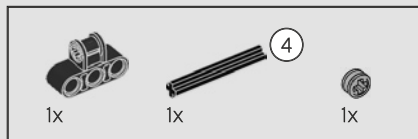

661

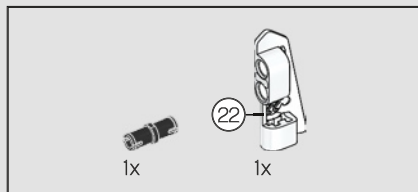
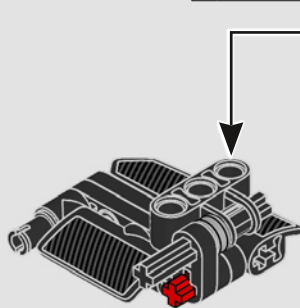
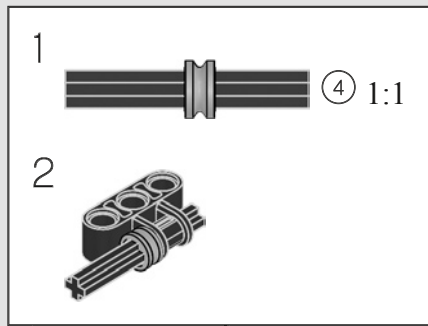

662

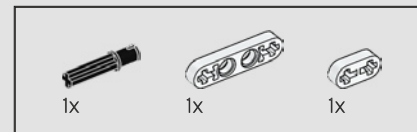
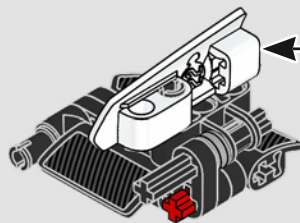
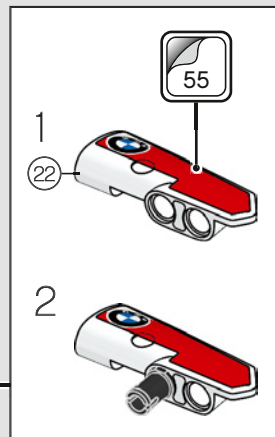

663

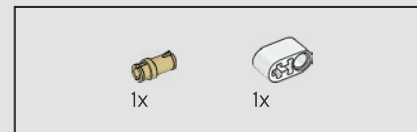
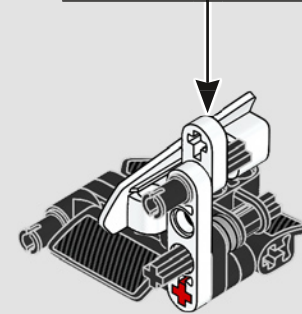
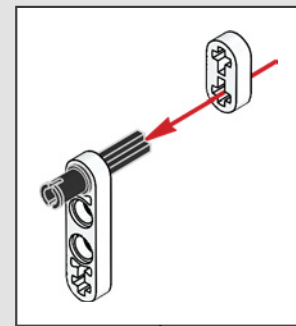

664

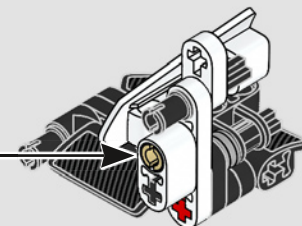
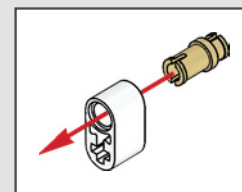

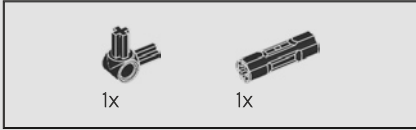
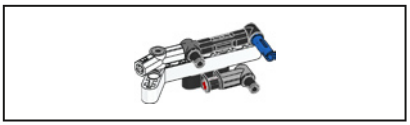

665

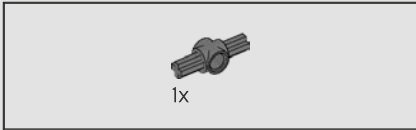
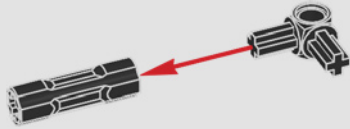

666

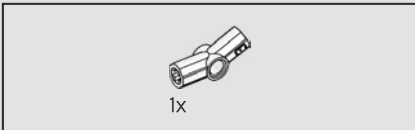
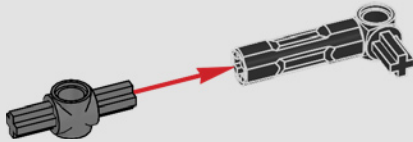

667

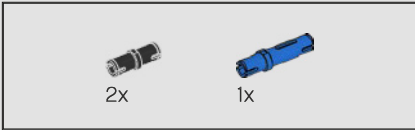

668

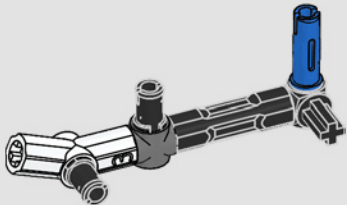

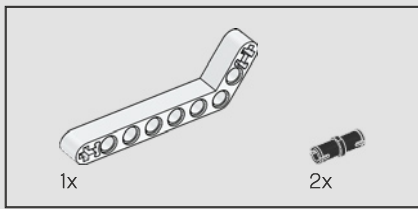

669

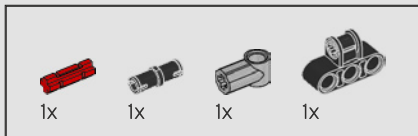
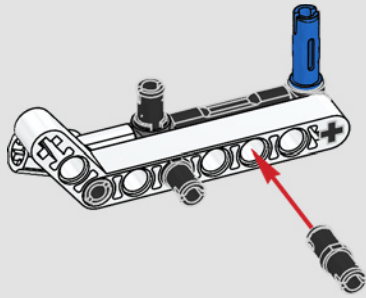

670

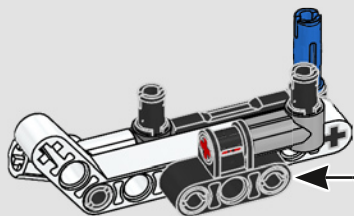
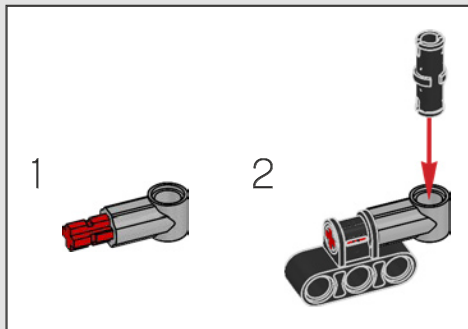

671

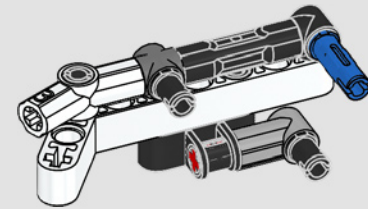

672

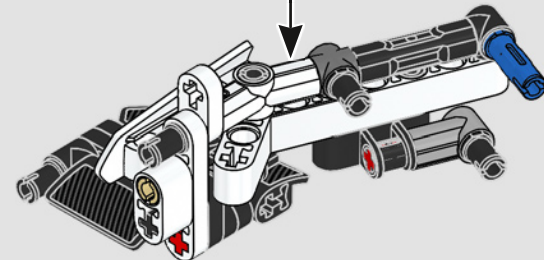



673

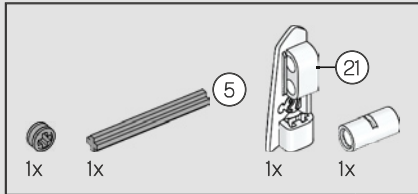
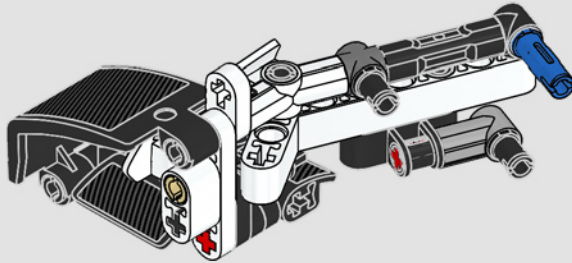
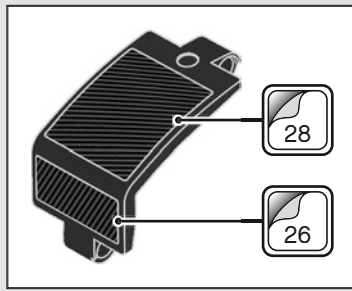

674

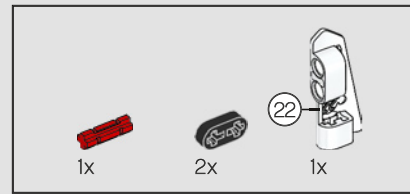
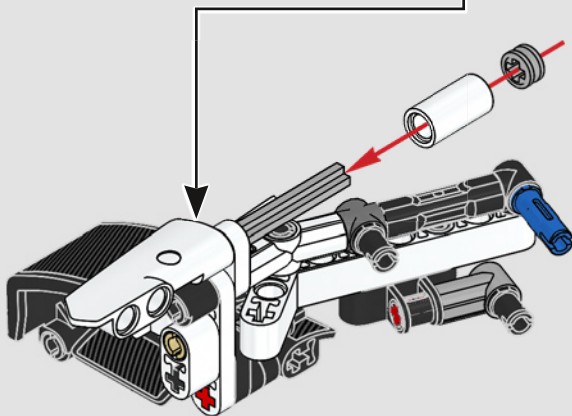
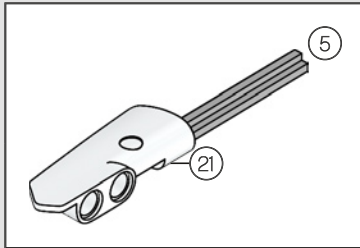

675

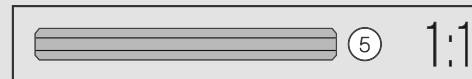
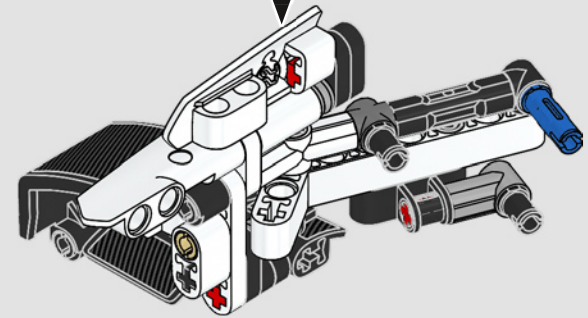
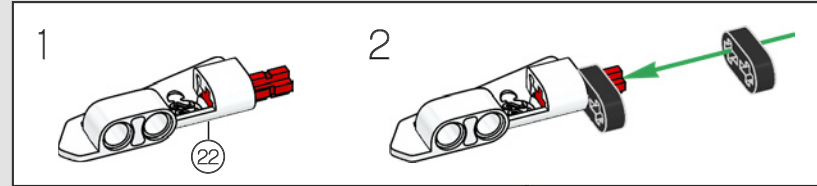

676

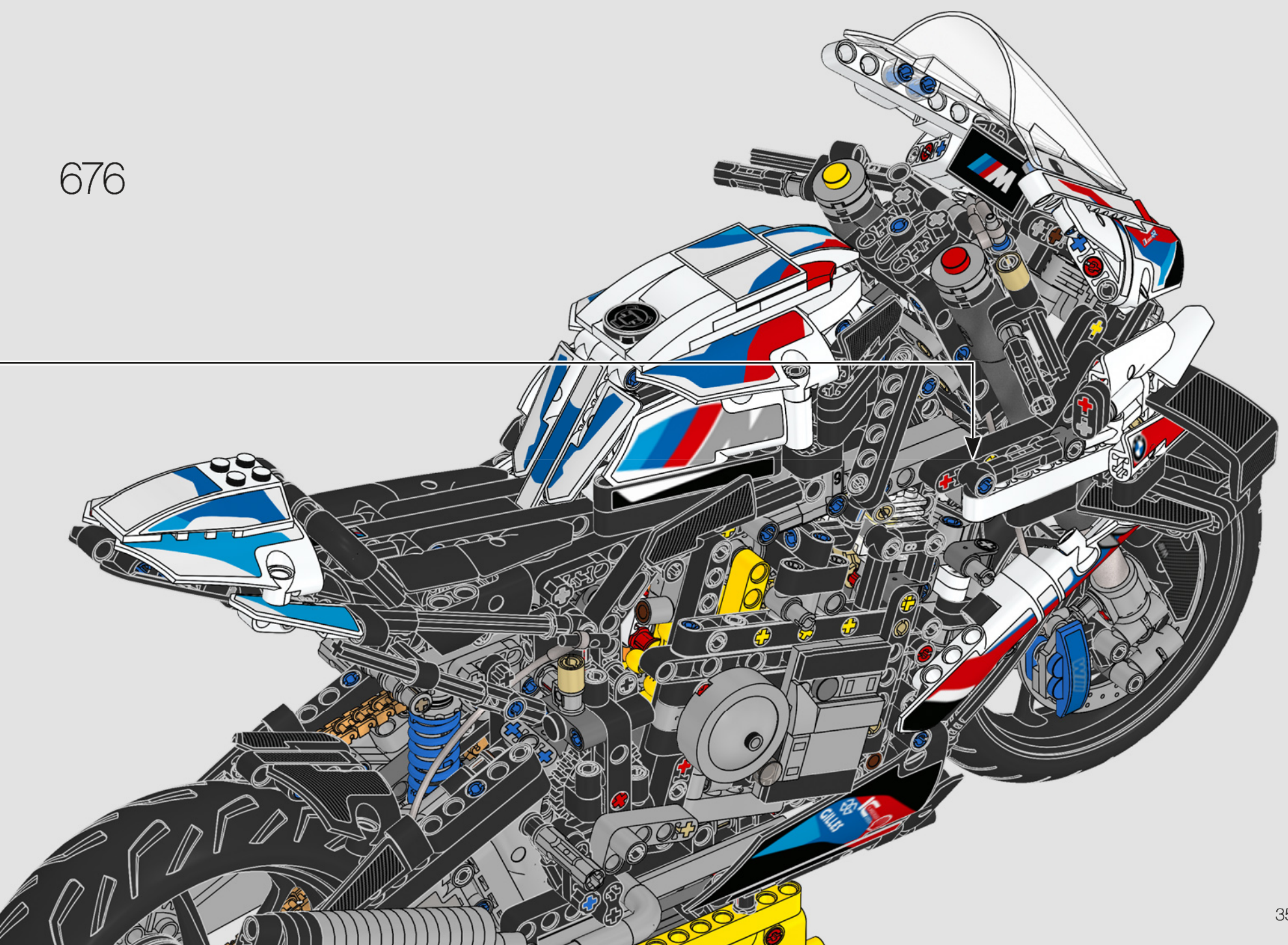

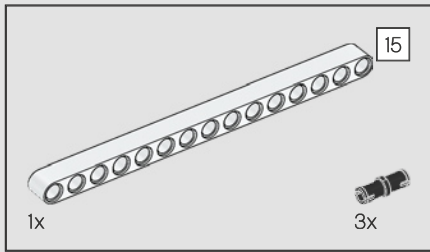
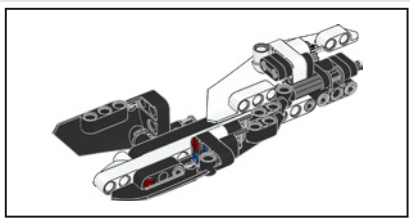

677

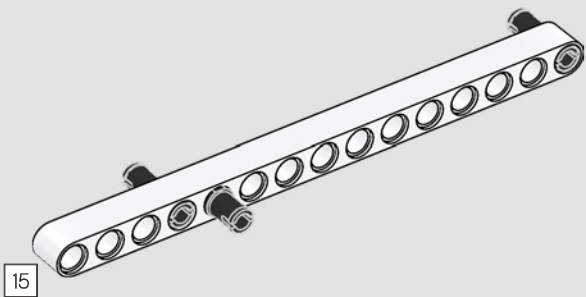

678

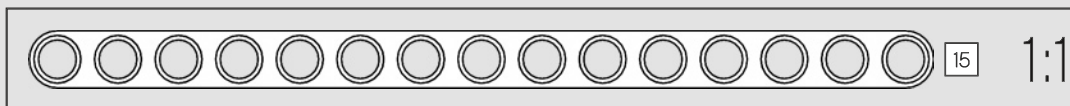
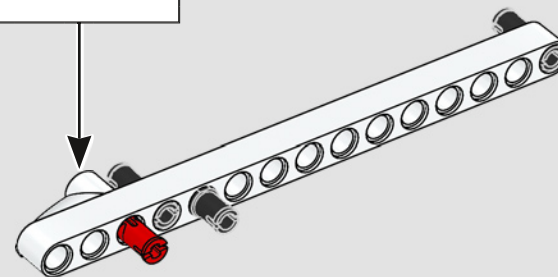
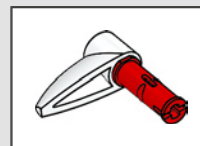

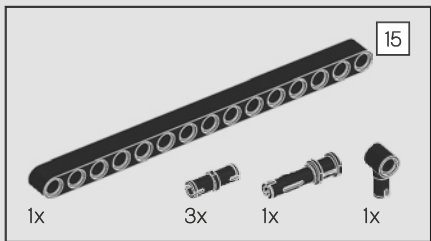

679

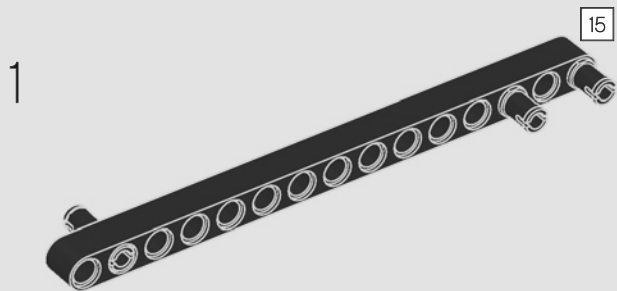

2

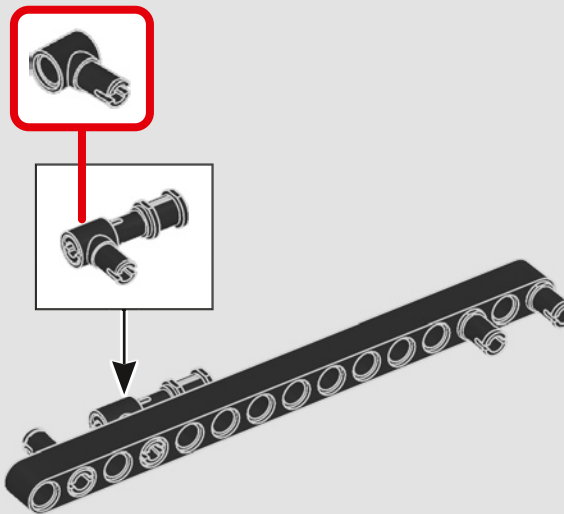

680

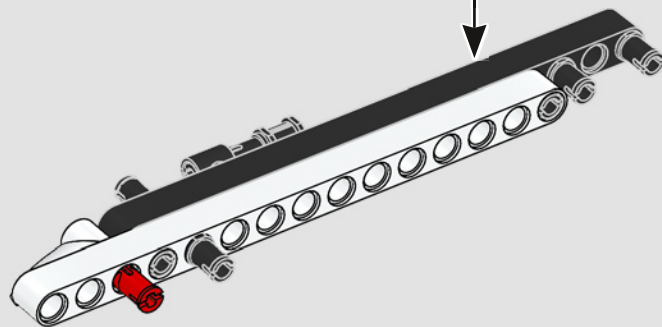

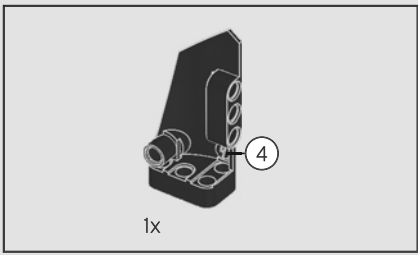

681

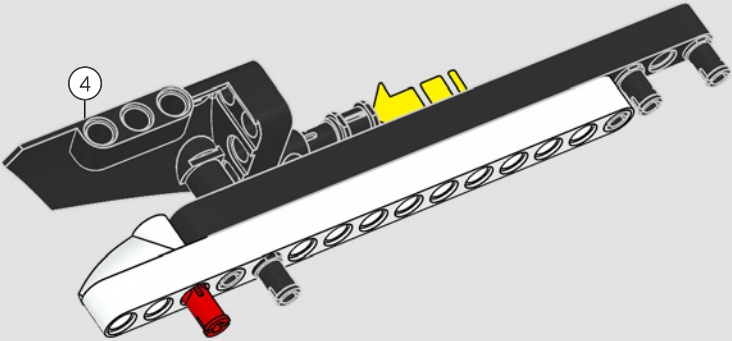

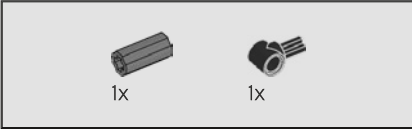
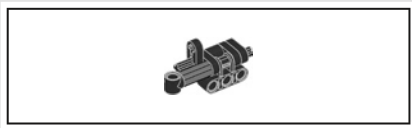

682

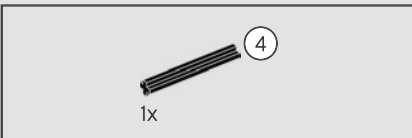
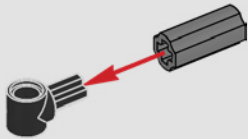

683

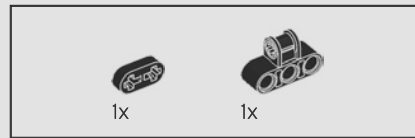
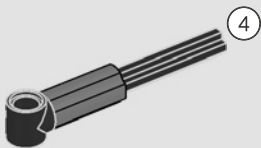
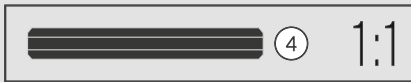

684

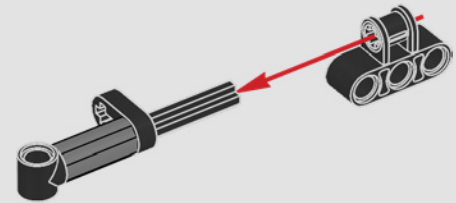

685

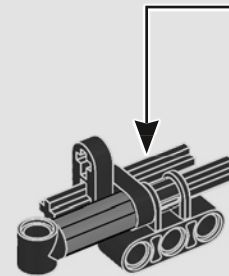



686

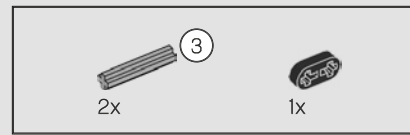
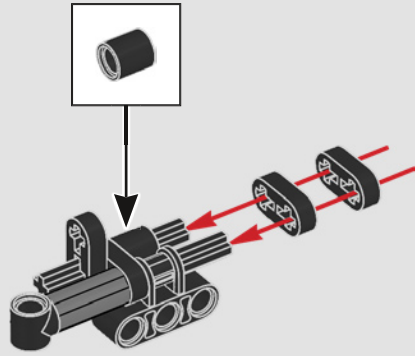

688

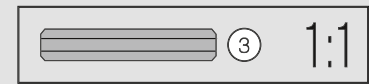
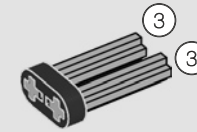

689

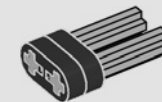

687

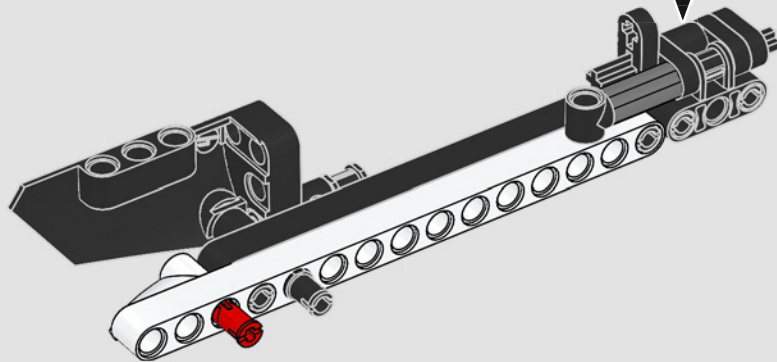

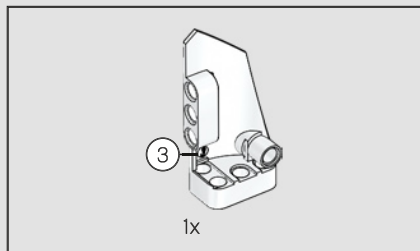

690

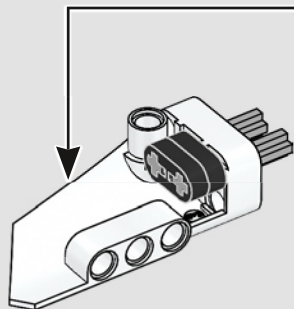
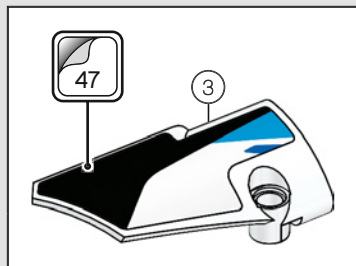

691

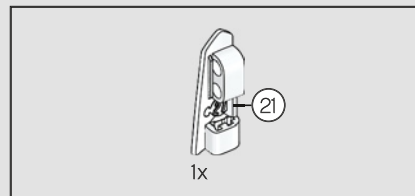
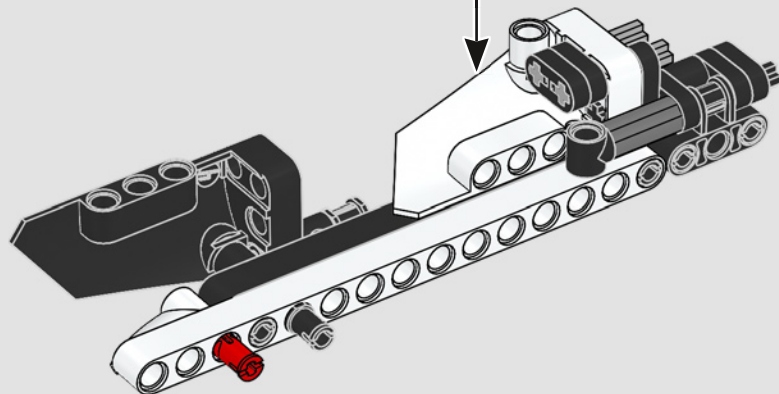

692

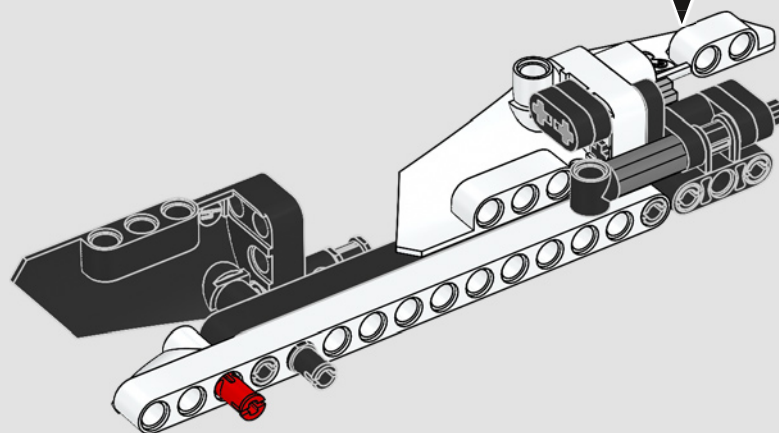
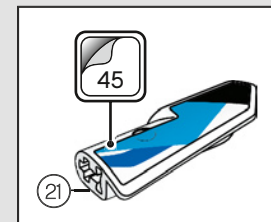

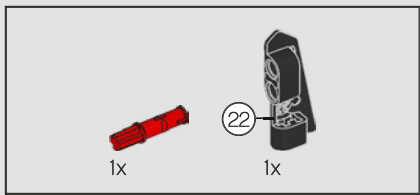

693

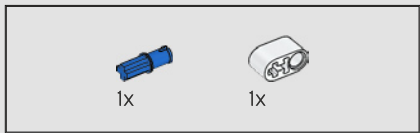
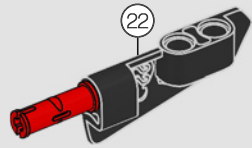

694

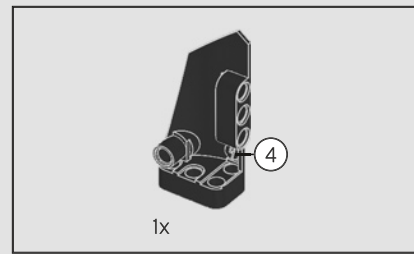
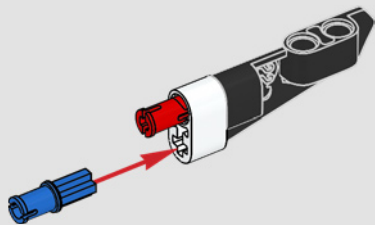

695

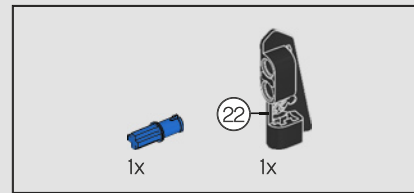
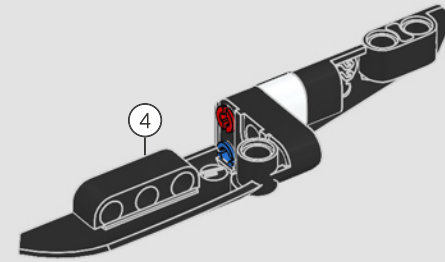

696

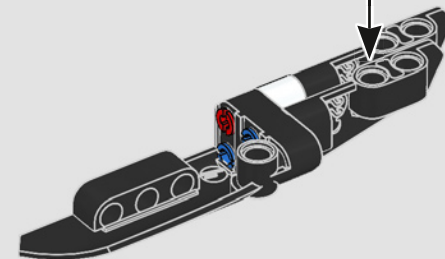
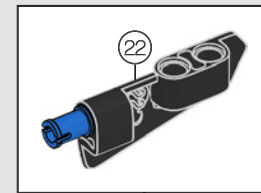

697

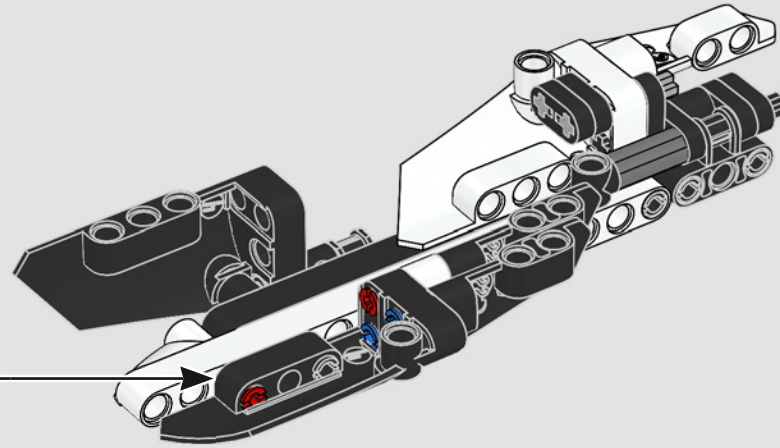

698

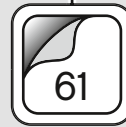
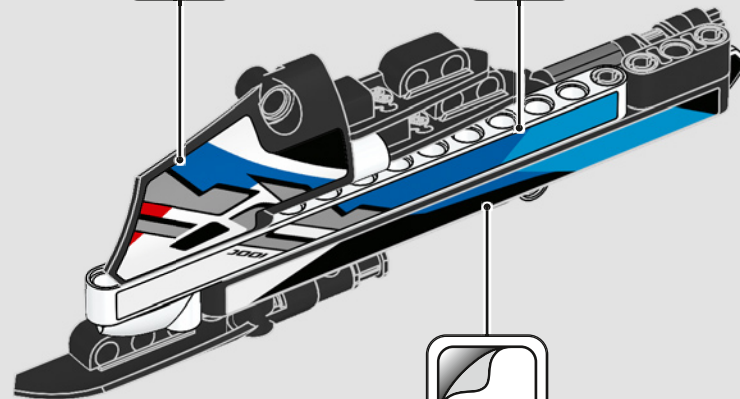

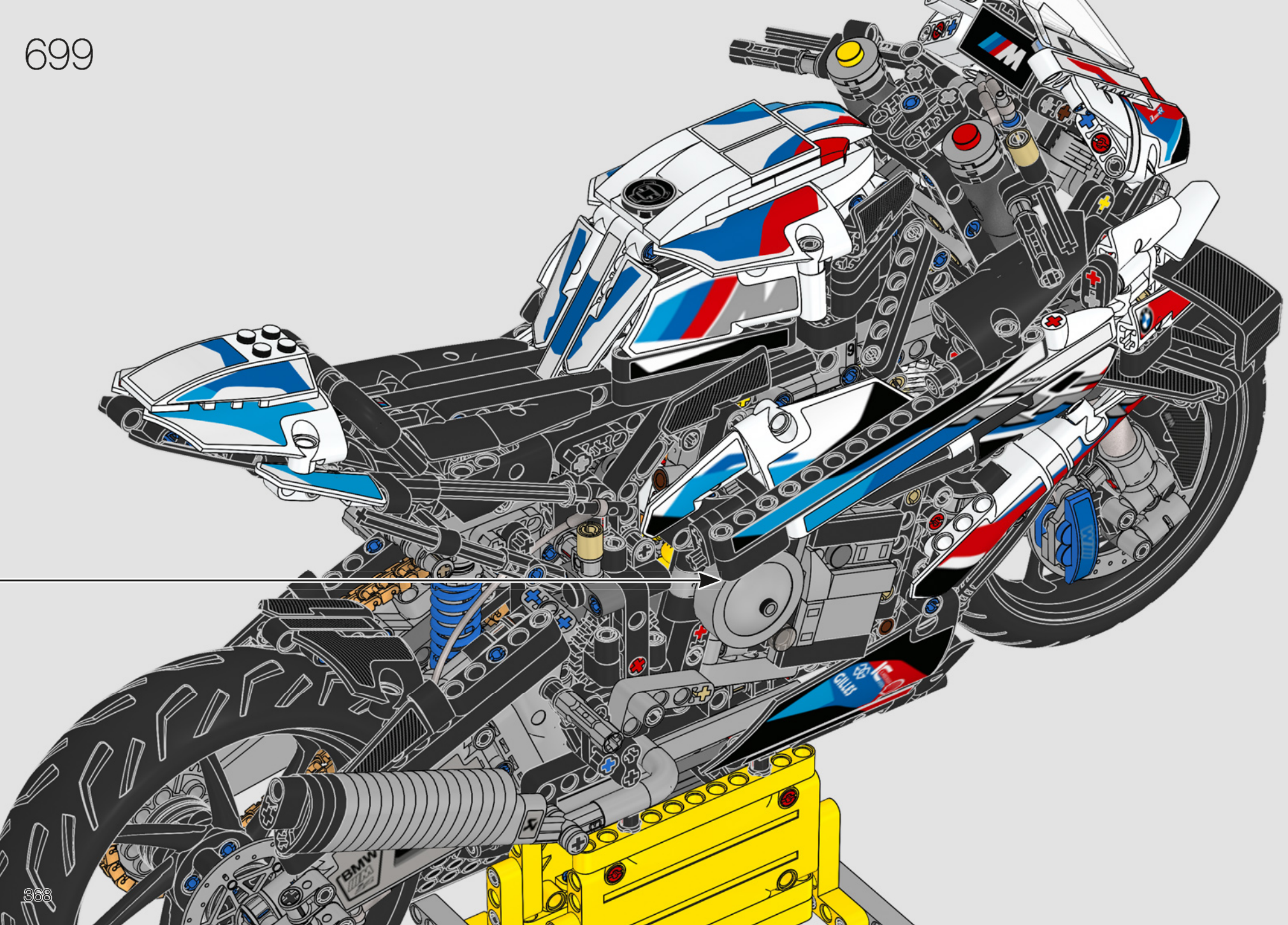

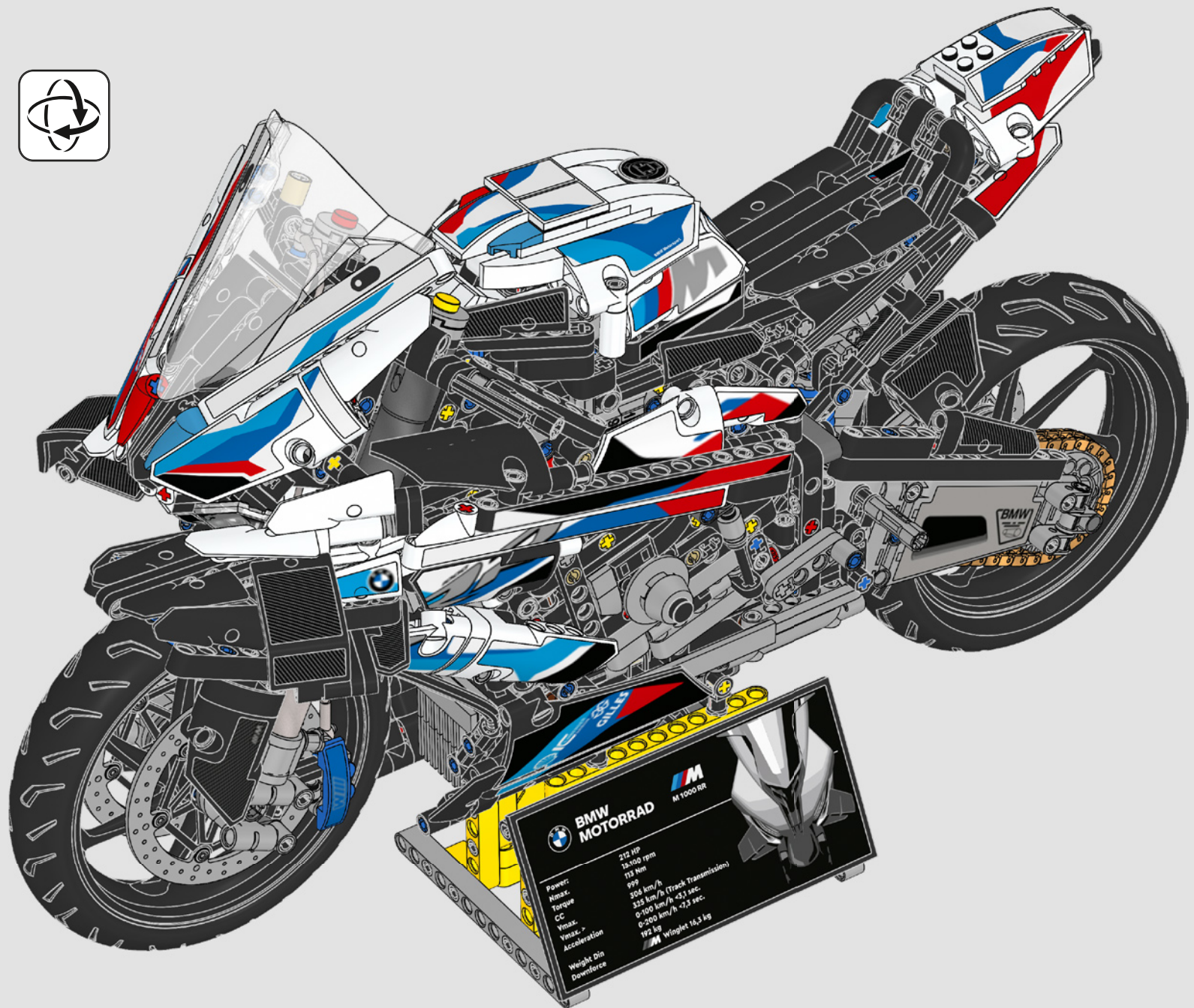

BMW MOTORRAD M 1000 RR

Power:	212 HP
rpmax:	15,500 rpm
Torque:	119 Nm
CC	999
Vmax:	306 km/h (Track Transmission)
Acceleration	0-100 km/h ≤ 3.1 sec.
Weight	0-200 km/h ≤ 7.3 sec.
Downforce	192 kg
	Winglet 16.3 kg

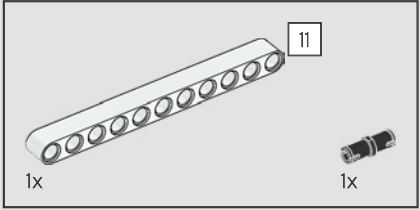
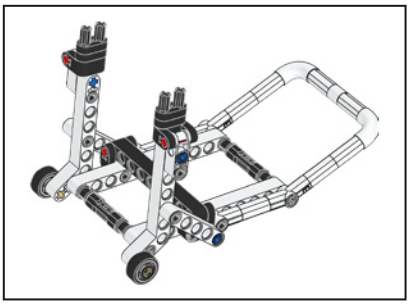

1

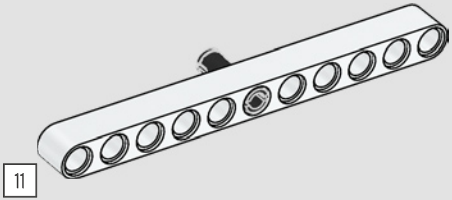

2

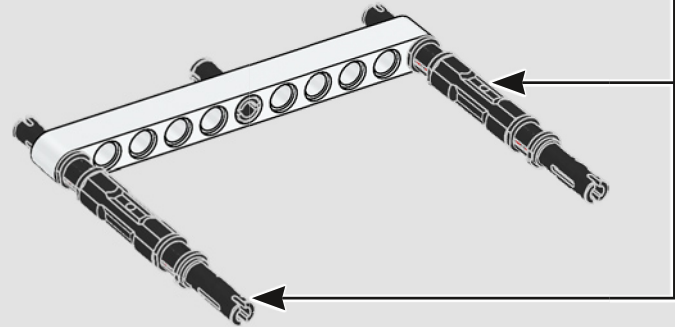
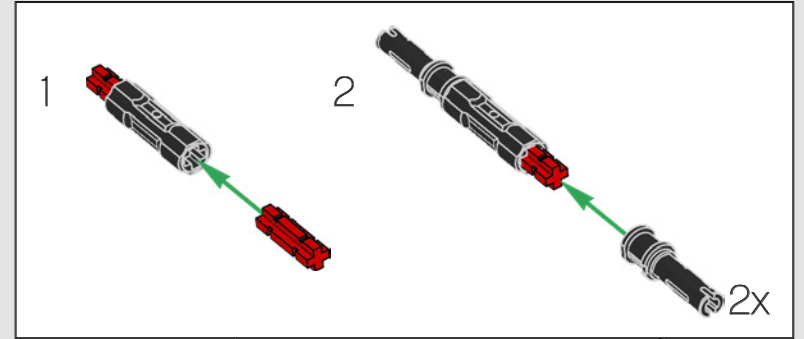

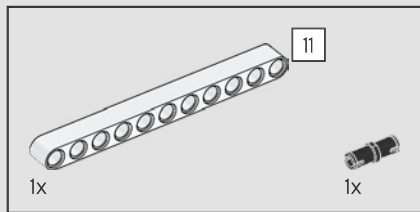

3

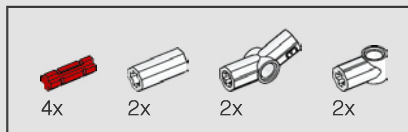
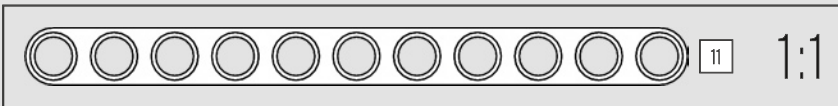
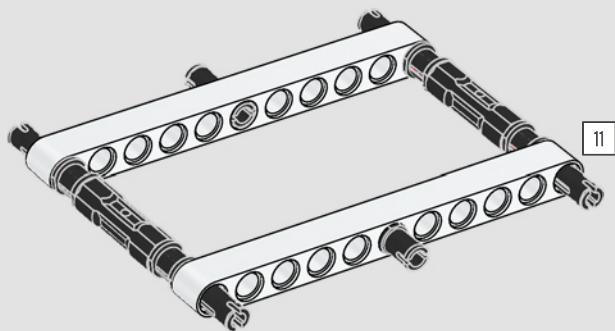

4

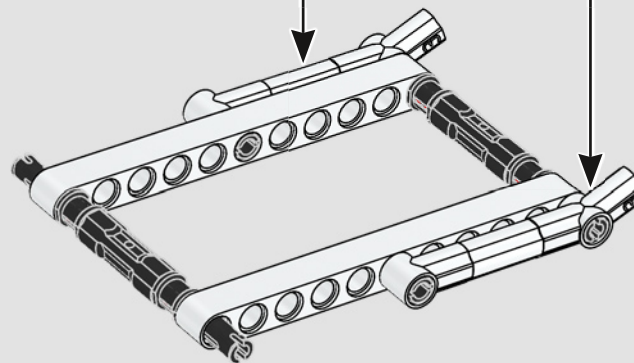
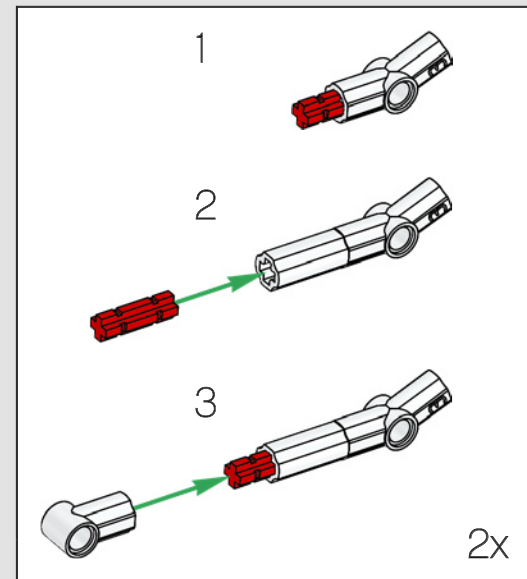

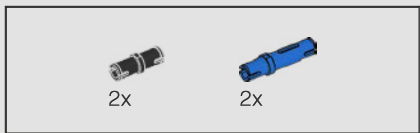

5

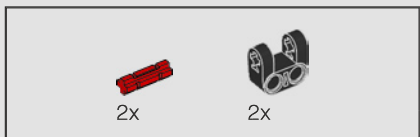
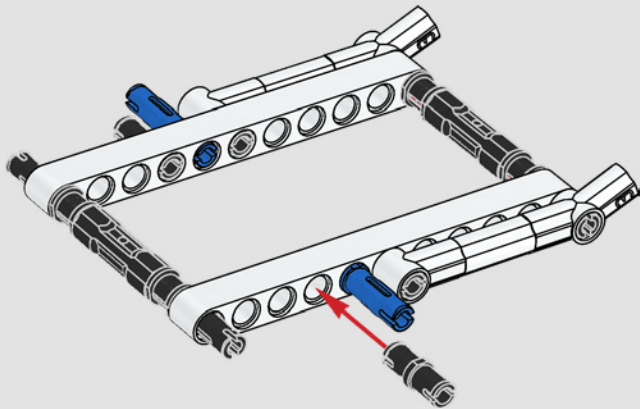

6

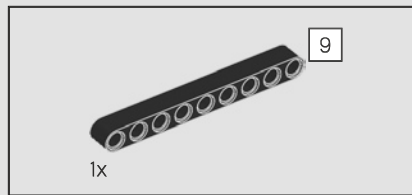
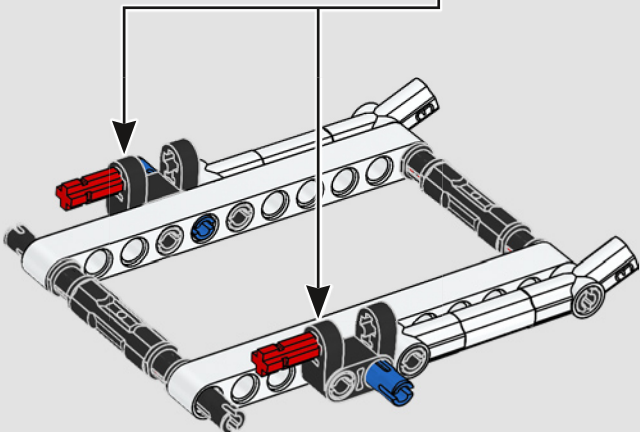
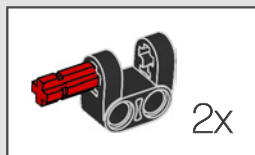

7

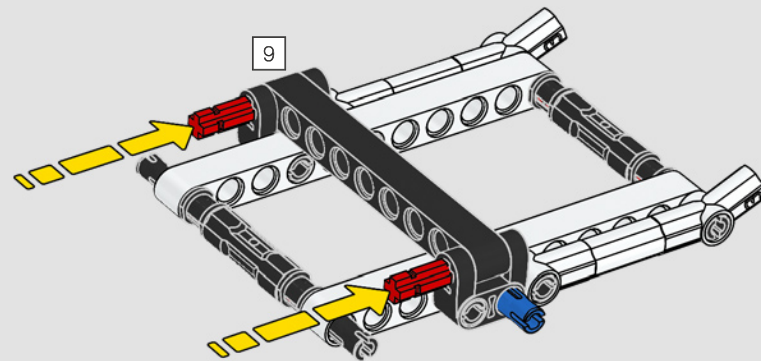

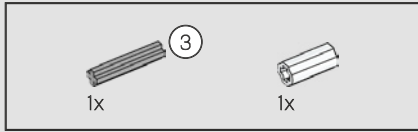
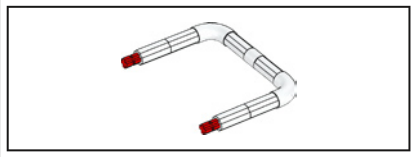

8

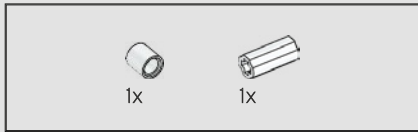
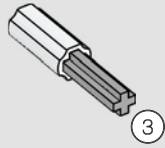

9

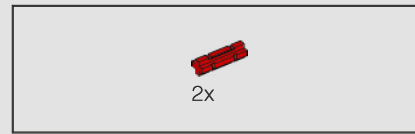
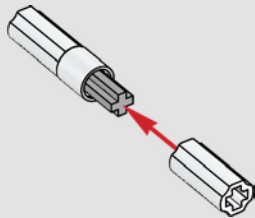

10

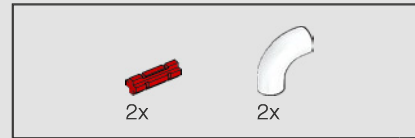
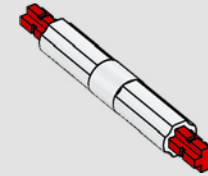

11

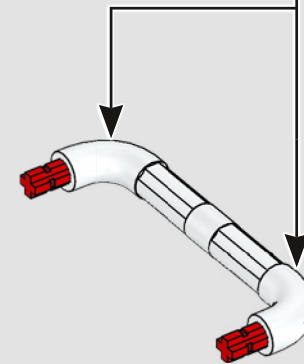
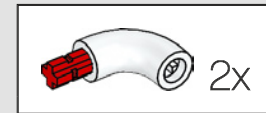

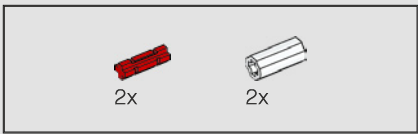

12

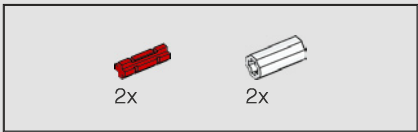
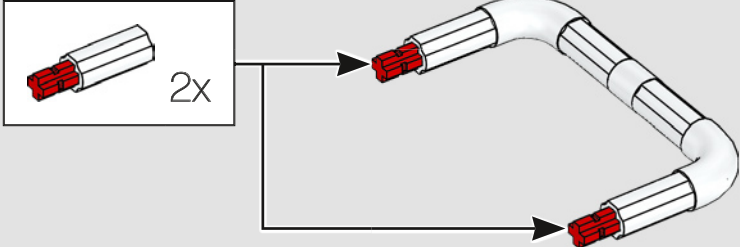

13

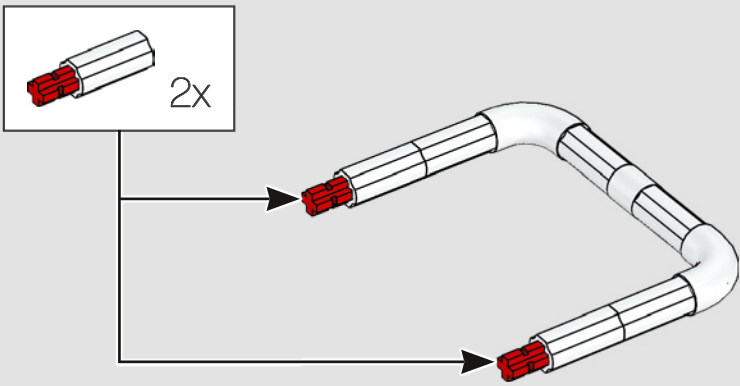

14

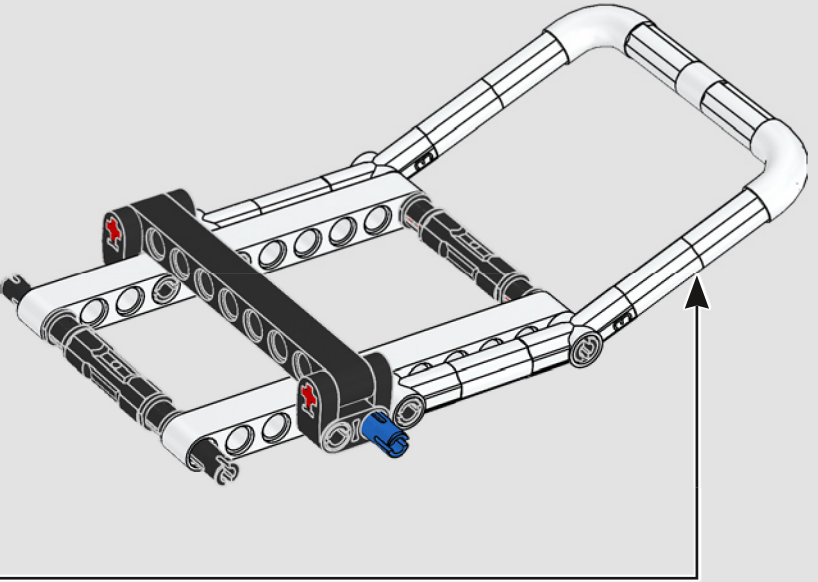

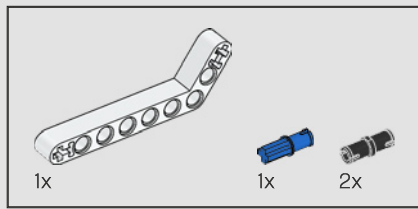

15

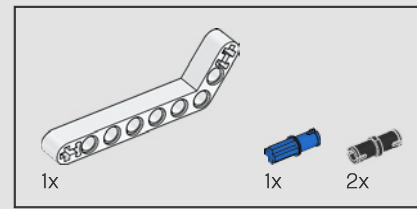
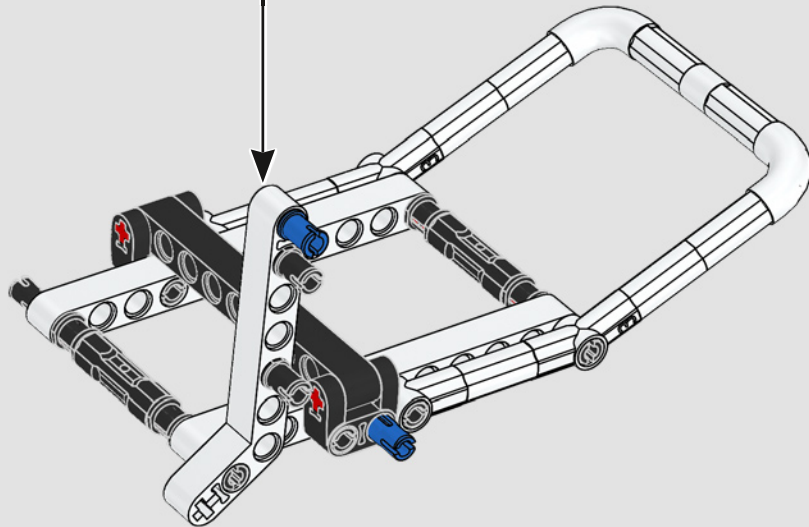
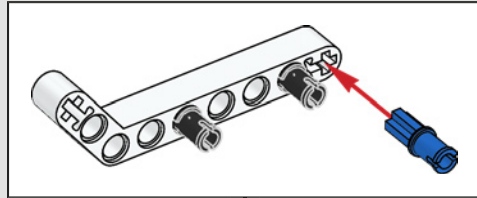

16

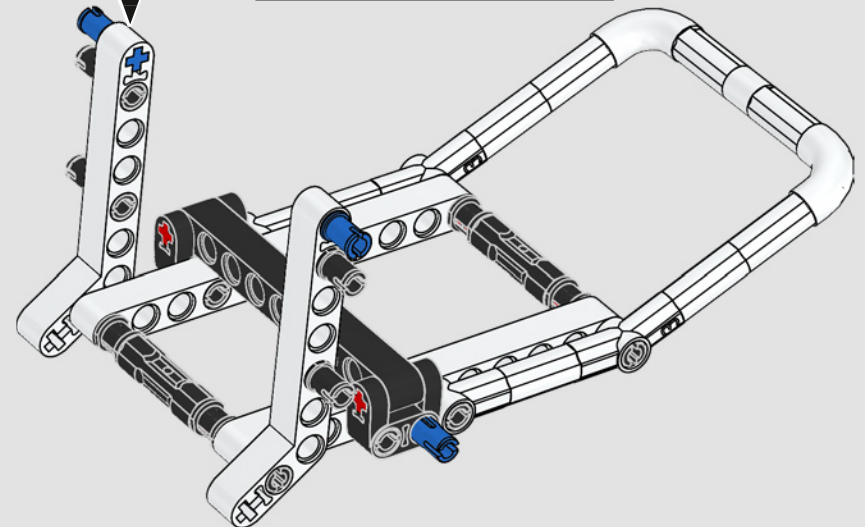
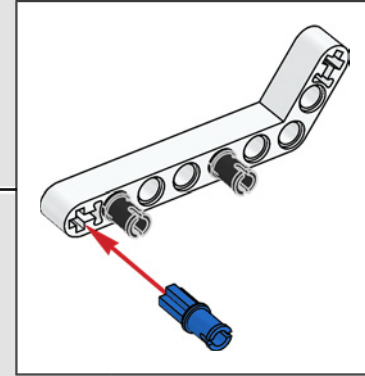

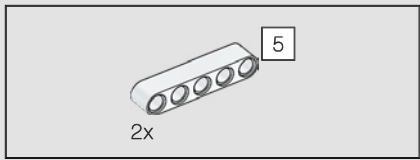

17

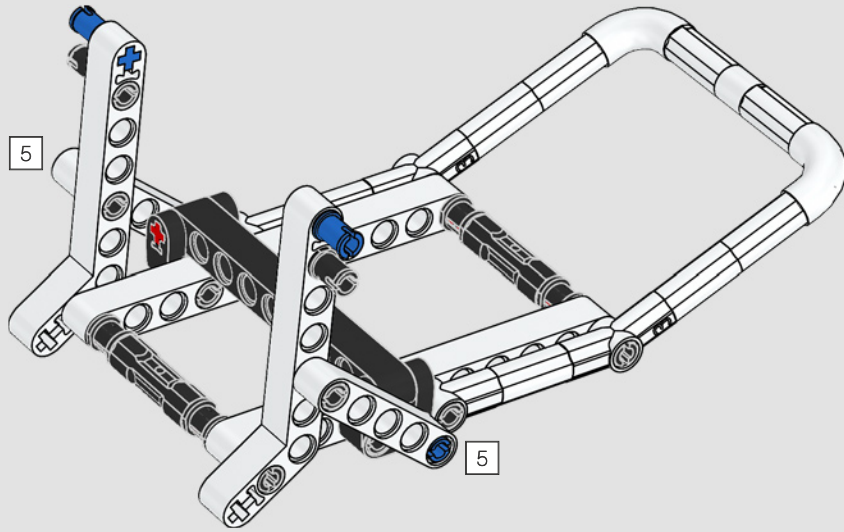

18

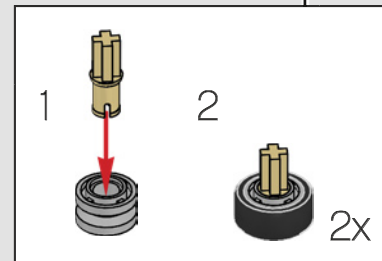
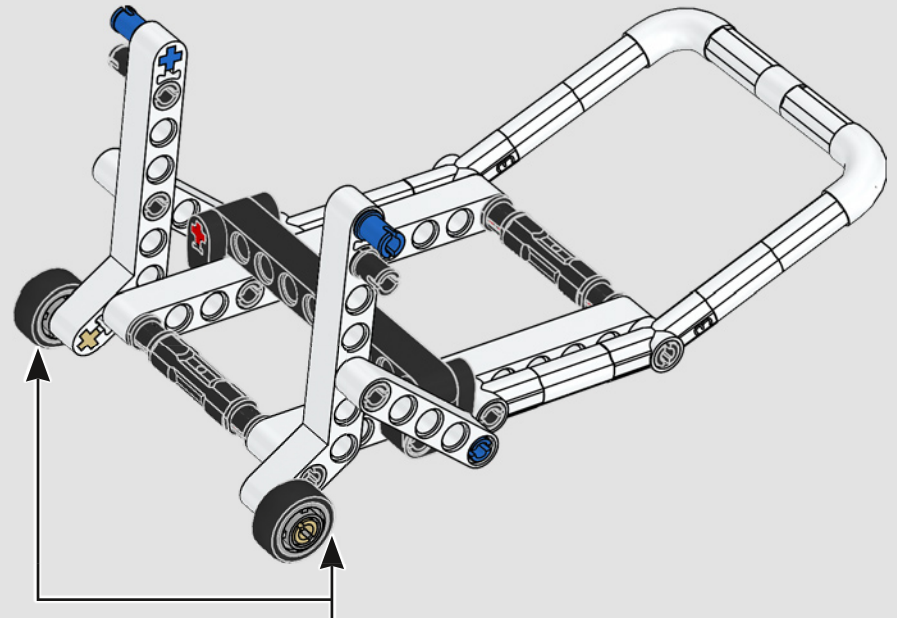



19

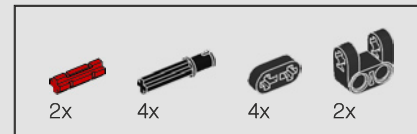
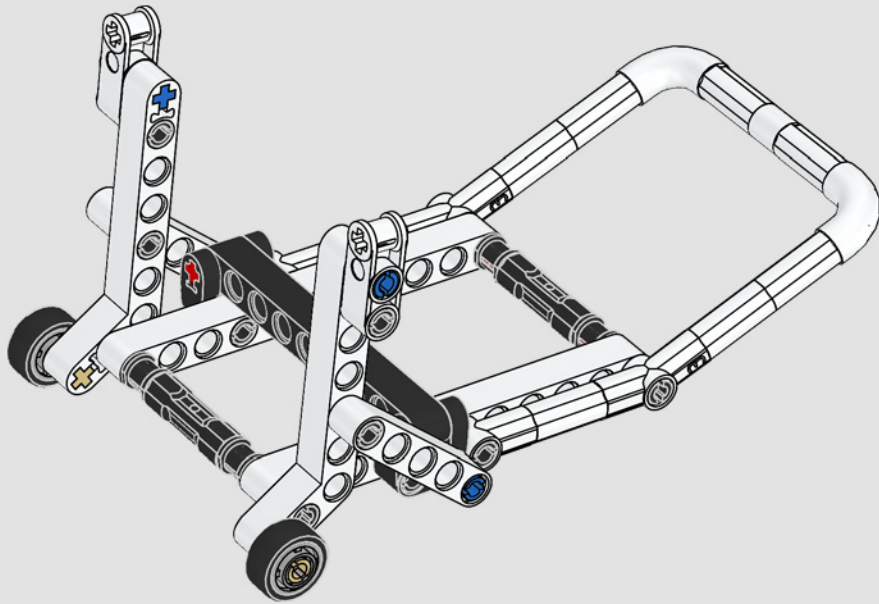

20

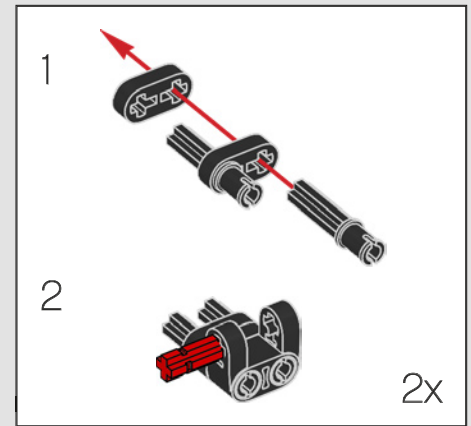
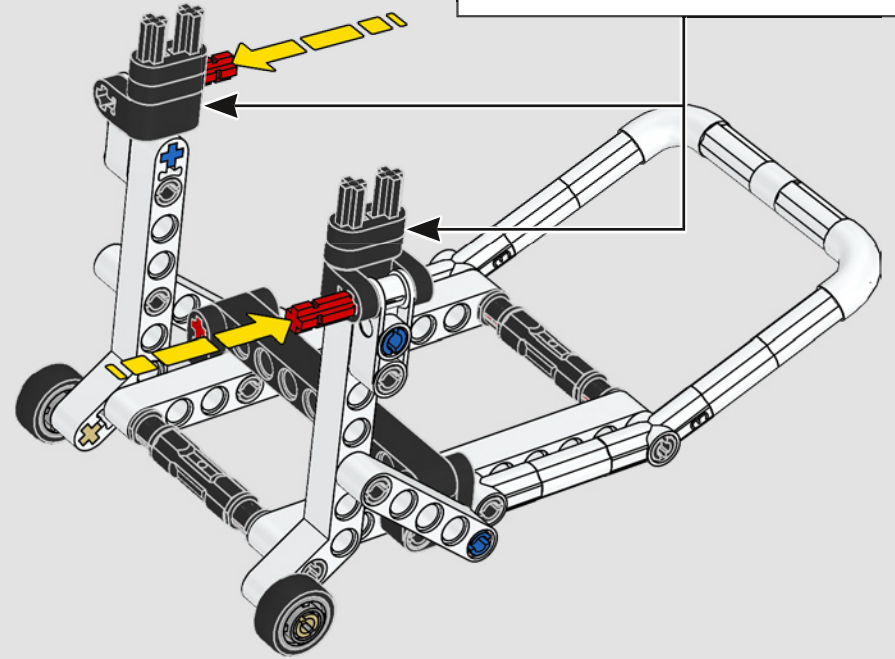

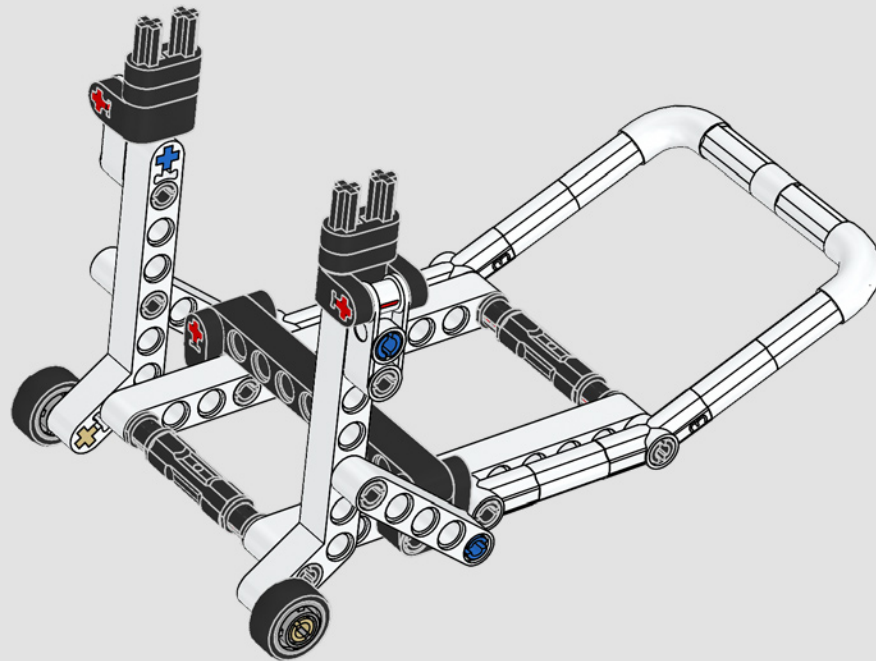

700

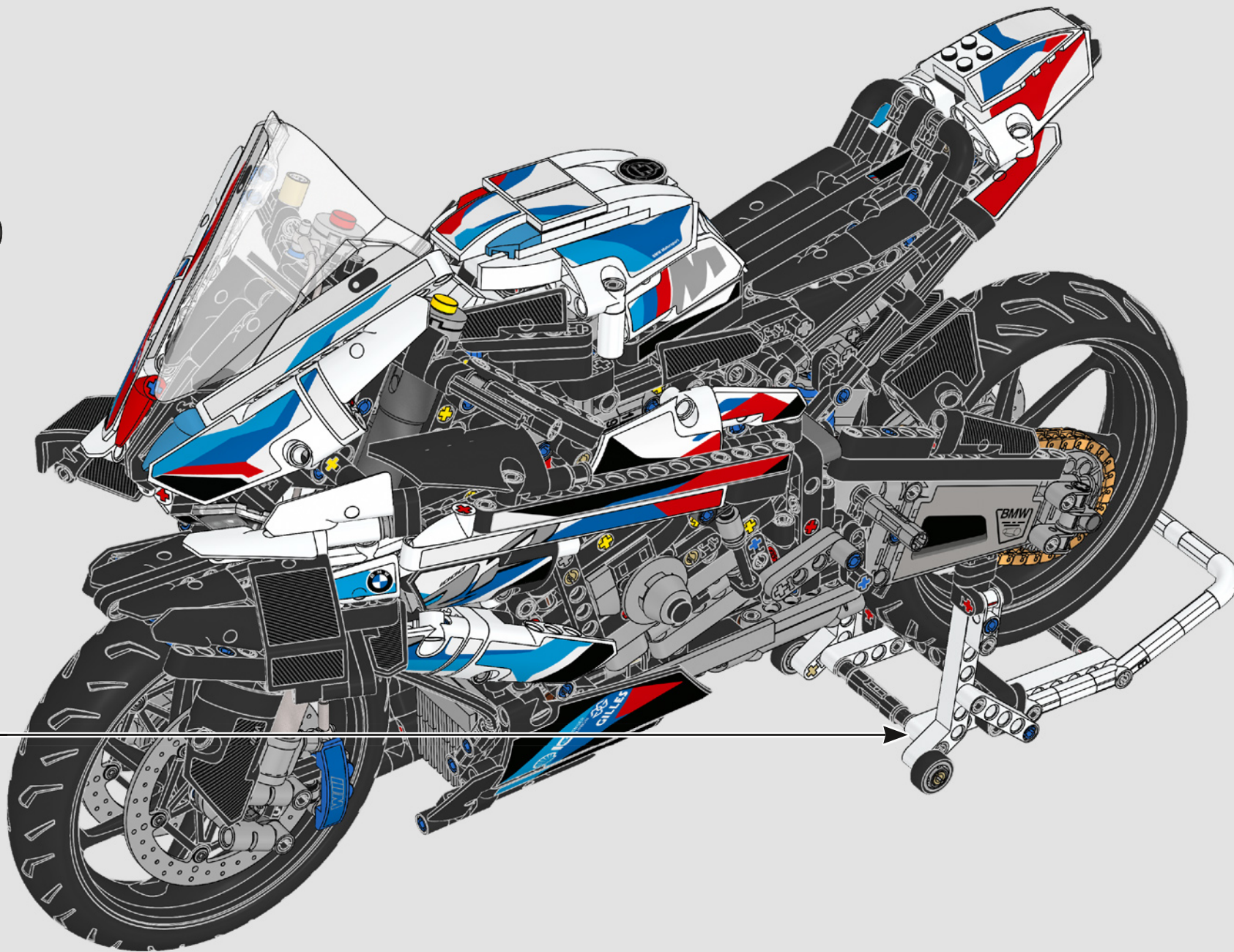

- 1x 6177114
- 2x 6282148
- 2x 4544140
- 7x 6343987
- 10x 6371416
- 2x 6323918
- 7x 6330084
- 2x 6332573
- 2x 6194851
- 2x 6179606
- 7x 6265135
- 4x 6345327
- 8x 6212049
- 2x 3200001
- 6x 6173116
- 3x 6034044
- 2x 6271349
- 2x 6288218
- 2x 6330960
- 1x 6047220
- 4x 6261390
- 2x 6271870
- 2x 4249112
- 1x 362301
- 2x 4249021
- 2x 366601
- 1x 4558874
- 1x 4558878
- 2x 6360072
- 6x 4547582
- 2x 302101
- 1x 6132212
- 2x 6156667
- 6x 4547581
- 2x 6045936
- 2x 302001
- 2x 4249021
- 2x 366601
- 1x 4179869
- 5x 6276842
- 4
- 9
- 11
- 15
- 3
- 5
- 2
- 1

- 1x 303401
- 4x 6001831
- 4x 6028103
- 2x 4542578
- 3x 6167923
- 15x 6013938
- 3x 6355727
- 5x 4666579
- 2x 6346517
- 1x 6321305
- 2x 4666999
- 1x 6284574
- 13x 6271820
- 4x 6360104

- 1x 6177507
- 62x 4142865
- 2x 6167939
- 7x 6100930
- 1x 4179355
- 1x 6285599
- 1x 6273712
- 37x 6209519
- 5x 6347789
- 3x 6273211
- 4x 6129995
- 1x 4142132
- 1x 6130002
- 2x 6130004
- 4x 6284575
- 37x 4143005
- 4
- 5
- 6
- 8

- 2x 6315482
- 69x 4206482
- 1x 6224999
- 2x 6344176
- 132x 6299413
- 2x 4649773
- 1x 6284577
- 4x 4112203
- 1x 403224
- 2x 4187122
- 2x 4119474
- 3x 6284189
- 7x 6130008
- 10x 4144022
- 7
- 7
- 9
- 11
- 11
- 6x 6028107
- 7x 6130012
- 2x 6311003
- 1x 6170421
- 3x 6284070
- 3x 6168646
- 17x 6121485
- 23x 6282140
- 1x 6181720

- 2x 4177431
- 14x 6319983
- 2x 6196548
- 1x 6181713
- 3x 4143187
- 2x 4246901
- 43x 6338428
- 6x 6322045
- 4x 6261371
- 12x 6316923
- 6x 6284699
- 207x 6279875
- 2x 403226
- 4x 6179182
- 1x 6070695
- 16x 6253260
- 8x 6099801
- 34x 6265091
- 10x 6326047
- 8x 4512363
- 4x 6280394
- 6x 6331716
- 10x 6349281
- 2x 6268905
- 1x 6174243
- 1x 6047276
- 1x 6156991
- 2x 6147050
- 4x 6271346
- 3x 6325521
- 21
- 22

- 8x 6313520
- 2x 6262897
- 10x 6271810
- 4x 6323668
- 3x 6273708
- 2x 242026
- 2x 4124096
- 25x 6089119
- 27x 6321745
- 4x 4107765
- 4x 6261386
- 1x 6276951
- 3x 4552347
- 2x 4142822

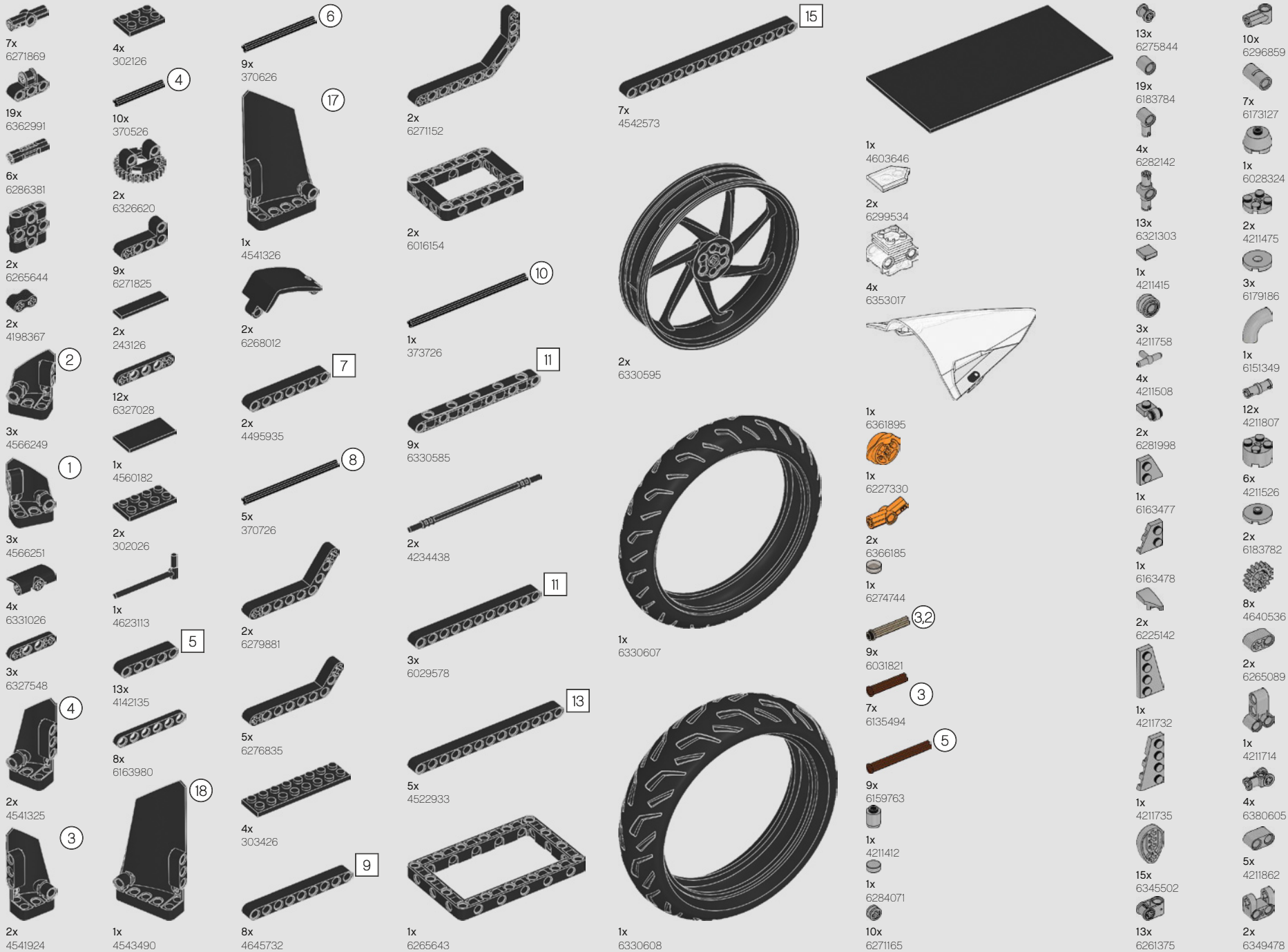



2x
6280396



4x
6268924



6x
6168633



2x
6134378



2x
4211469



30x
4211350



4x
6000018



1x
4667578



2x
6331859



4x
6360043



2x
6262905



7x
6273724



4x
6279023



4x
4211397



1x
4490127



33x
4211815



1x
4211536



1x
6261387



2x
4652235



13x
6276969



3x
6331441



2x
6282158



1x
6070564



1x
4211429



1x
6211969



1x
4558169



2x
6302648



2x
6317177



1x
6013547



1x
6011808



2x
6273212



2x
6370947



1x
4211396



1x
6171894



1x
6271831



2x
4211356



2x
4211445



1x
6303438



4x
6328063



4x
6331428



3x
4503416



7x
4211639



1x
6195314



2x
4211651



6x
4211713



1x
6285654



10x
6170293



1x
6278129



1x
4211549



6x
4211805



2x
4211452



9x
4495930



2x
6257136

5



2x
4211481



2x
6331551



1x
6102449



2x
4522934



2x
6327007

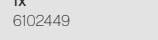

62x
6348019



2x
6116017

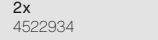

3x
6210590



2x
6328490

9

13



1x
6211418



1x
6292486



1x
6364922



1x
6284596



4x
4210759



8x
6261374



2x
6100931



3x
6135014



2x
4516546



2x
6364452



6x
6167281



1x
6133119



11x
4210751



1x
6317653



2x
4610378



3x
6271814



7x
6083620



3x
4499858



3x
6321715



1x
4603472



3x
6321715



2x
4645730



3x
6321715



1x
4603472



2x
4603472



2x
4603472



1x
4603472



1x
4603472



1x
4603472



Customer Service

Kundenservice

Service Consommateurs

Servicio Al Consumidor

LEGO.com/service or dial



00800 5346 5555 :



1-800-422-5346 :





FEEDBACK AND WIN



FEEDBACK AND WIN

Your feedback will help shape the future development of this product series.

Please visit:

FEEDBACK UND GEWINNEN

Dein Feedback trägt zur Weiterentwicklung dieser Produktreihe bei.

Geh auf:

COMMENTEZ ET GAGNEZ

Vos commentaires nous aideront à concevoir les futurs produits de cette gamme.

Rendez-vous sur :

COMENTA Y GANA

Tu opinión nos ayudará a dar forma al desarrollo de esta serie de productos en el futuro.

Visita:

反馈有奖

您的反馈将有助于我们在今后改进本系列产品。

请访问：

[LEGO.com/productfeedback](https://www.lego.com/productfeedback)

By completing, you will automatically enter a drawing to win a LEGO® set.

Terms & Conditions apply.

Durch Ausfüllen nimmst du automatisch an der Verlosung eines LEGO® Preises teil.

Es gelten die Teilnahmebedingungen.

En envoyant vos commentaires, vous serez automatiquement inscrit(e) à un tirage au sort qui vous permettra de remporter un prix LEGO®.

Offre soumise à conditions.

Al contestar, participarás automáticamente en el sorteo y podrás ganar un set LEGO®.

Sujeto a Términos y Condiciones.

完成我们的反馈调查,即可自动进入抽奖环节,赢取乐高®套装。

适用《条款和条件》。

LEGO and the LEGO logo are trademarks of the LEGO Group. ©2022 The LEGO Group.

The BMW logo, the BMW Motorrad word mark and the BMW Motorrad model designation are trademarks of BMW AG and are used under license.



M 1000 RR