



Disney



MICKEY & MINNIE
MOUSE MOUSE



43179

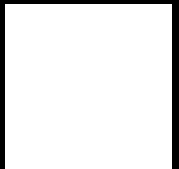

MICKEY & MINNIE MOUSE MOUSE

THE WORLD'S FAVORITE MICE LA SOURIS LA PLUS POPULAIRE DU MONDE LOS RATONES FAVORITOS DEL MUNDO ENTERO

A MIGHTY PAIR

Mickey Mouse made his public debut in Walt Disney's 1928 animated short *Steamboat Willie*, playing the role of a jolly riverboat pilot whistling at the helm. Two and a half minutes later, in the same film, Minnie Mouse made her own debut as a passenger rushing to board the boat. With a little help from a cargo crane, both mice finally met on deck – and

they've been inseparable ever since. *Steamboat Willie* is a work of incredible historical significance – it was the first Disney cartoon to feature synchronized sound and a fully post-produced soundtrack – and will be remembered for generations as the film that introduced Mickey and Minnie to each other, and the world.

LES DEUX FONT LA PAIRE

Mickey Mouse a fait sa première apparition en 1928 dans le court métrage d'animation de Walt Disney *Steamboat Willie*. On y voit le personnage jouer le rôle d'un joyeux matelot sifflant à la barre. Dans le même film, deux minutes et demie plus tard, on aperçoit Minnie Mouse dans le rôle d'une passagère se précipitant pour monter à bord du bateau. Grâce à l'aide d'une grue à chargement, les deux

souris se sont finalement rencontrées sur le pont, et sont depuis devenues inséparables. *Steamboat Willie* est une œuvre d'une importance historique incroyable. Il s'agit du premier film d'animation de Disney au son entièrement synchronisé et il contient la première bande sonore conçue en postproduction. C'est également le film qui a mis en vedette Mickey et Minnie pour la première fois.

UNA PODEROSA PAREJA

Mickey Mouse debutó públicamente en 1928, en un cortometraje de animación de Walt Disney titulado *El barco de vapor Willie* en el que interpretaba el papel del alegre timonel de un barco fluvial mientras silbaba al timón. Dos minutos y medio más tarde, en el mismo cortometraje, Minnie Mouse aparecía por primera vez como una pasajera que trataba de subir al barco en el último minuto. Con un poco de ayuda de una grúa de carga, ambos ratones se

encontraron por fin en cubierta y, desde entonces, no han vuelto a separarse. *El barco de vapor Willie* es una obra de increíble importancia histórica (fue la primera caricatura de Disney en ofrecer sonido sincronizado y una banda sonora totalmente posproducida) que será recordada durante generaciones como la película que presentó a Mickey y a Minnie entre sí y a todo el mundo.

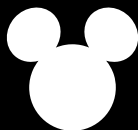

MICKEY AND MINNIE

A R E

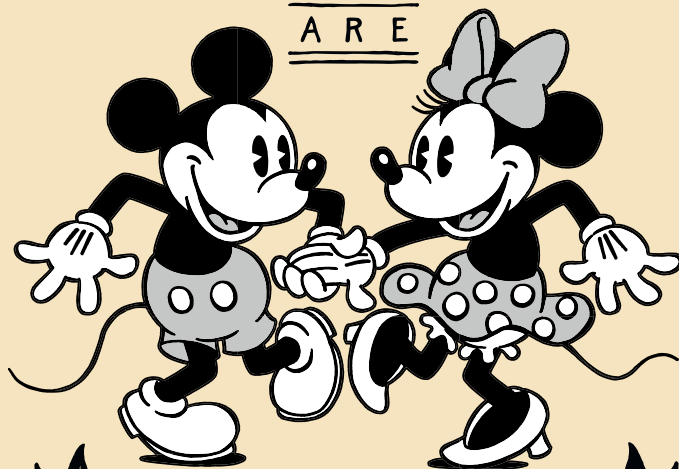

A GREAT PAIR
... SO SWEET ...

*Mickey and Minnie
appeared together in
70 of the 129 original
Mickey Mouse cartoons.*

*Mickey et Minnie sont
apparus ensemble dans
70 des 129 dessins animés
originaux de Mickey Mouse.*

*Mickey y Minnie
aparecieron juntos en
70 de las 129 caricaturas
originales de Mickey Mouse.*

BEAUTIFULLY SIMPLE

Mickey Mouse's design (and by extension Minnie's) is remarkably simple – basically, a set of circles. This allowed Walt Disney and designer Ub Iwerks to produce cartoons at lightning speed: up to 700 drawings in one day!

SIMPLICITÉ MAGNIFIQUE

La conception de Mickey Mouse (et de Minnie) est toute simple : il s'agit essentiellement d'un ensemble de cercles. Cela a permis à Walt Disney et au concepteur Ub Iwerks de produire des dessins animés à la vitesse de l'éclair : jusqu'à 700 dessins par jour !

HERMOSAMENTE SENCILLO

El diseño de Mickey Mouse (y, por extensión, el de Minnie) es notablemente sencillo: básicamente, no es más que una serie de círculos. Eso permitió a Walt Disney y al diseñador Ub Iwerks crear caricaturas a la velocidad de la luz, ¡llegando a producir hasta 700 dibujos en un día!

MICKEY IN WALT DISNEY'S WORDS

MICKEY DÉCRIT PAR WALT DISNEY

MICKEY EN PALABRAS DE WALT DISNEY

"I hope we never lose sight of one thing – that it was all started by a mouse."

« J'espère que l'on se souviendra que tout cela a commencé avec une souris. »

"Espero que nunca perdamos de vista una cosa: que todo comenzó con un ratón."

ON MICKEY'S POPULARITY

"Mickey is so simple and uncomplicated, so easy to understand, that you can't help liking him."

À PROPOS DE LA POPULARITÉ DE MICKEY

« Mickey est un personnage si simple et attachant. Il est si facile de le comprendre qu'il est difficile de ne pas l'aimer. »

SOBRE LA POPULARIDAD DE MICKEY

"Mickey es tan sencillo y natural, tan fácil de entender, que no puedes evitar que te guste".

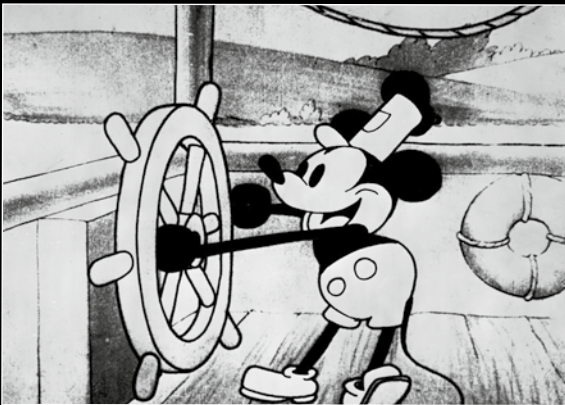

ON DREAMING UP MICKEY ON A TRAIN RIDE HOME

"Out of the trouble and confusion stood a mocking, merry little figure, vague and indefinite at first. But it grew and grew and grew, and finally arrived – a mouse. A romping, rollicking little mouse... By the time my train had reached the Middle West, I had dressed my dream mouse in a pair of red velvet pants with two huge pearl buttons. I had composed the first scenario and was all set."

À PROPOS DU MOMENT OÙ WALT DISNEY A IMAGINÉ MICKEY : À BORD D'UN TRAIN

« Dans tout ce brouhaha se dessinait un petit personnage joyeux et malicieux. D'abord indéfinissable, cette vision s'est précisée de plus en plus, pour finalement se matérialiser en... une souris. Une petite souris fougueuse et énergique. Au moment où mon train avait atteint le Midwest, j'avais déjà pensé à un habillement pour ma souris de rêve : un pantalon en velours rouge avec deux énormes boutons en perle. J'avais écrit le premier scénario et j'étais prêt pour la suite. »

SOBRE EL SUEÑO CON MICKEY A BORDO DE UN TREN DE REGRESO A CASA

"De la angustia y la confusión surgió una figurita burlona y alegre, vaga e indefinida al principio. Pero creció, creció y creció, y al fin llegó: un ratón. Un ratoncito risueño y juguetón... Para cuando mi tren llegó al Medio Oeste, ya le había puesto al ratón de mi sueño unos pantalones de terciopelo rojo con dos grandes botones de nácar. Había compuesto el primer escenario y todo estaba listo".

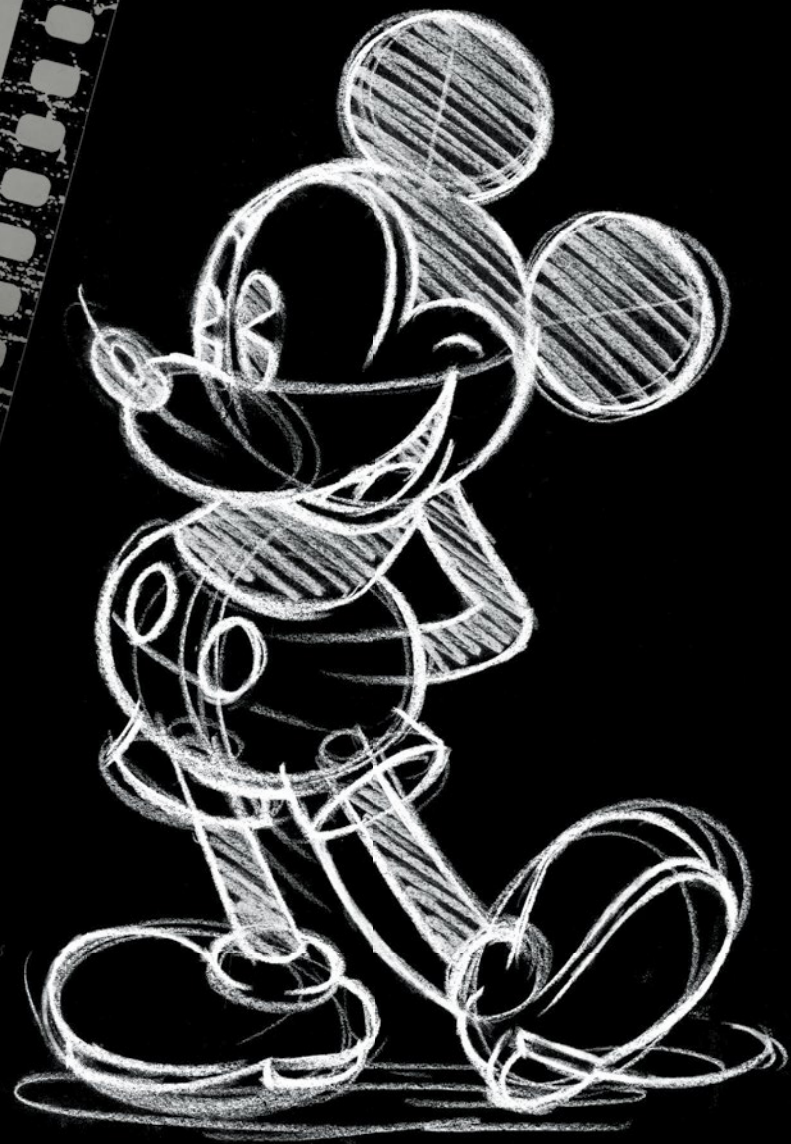
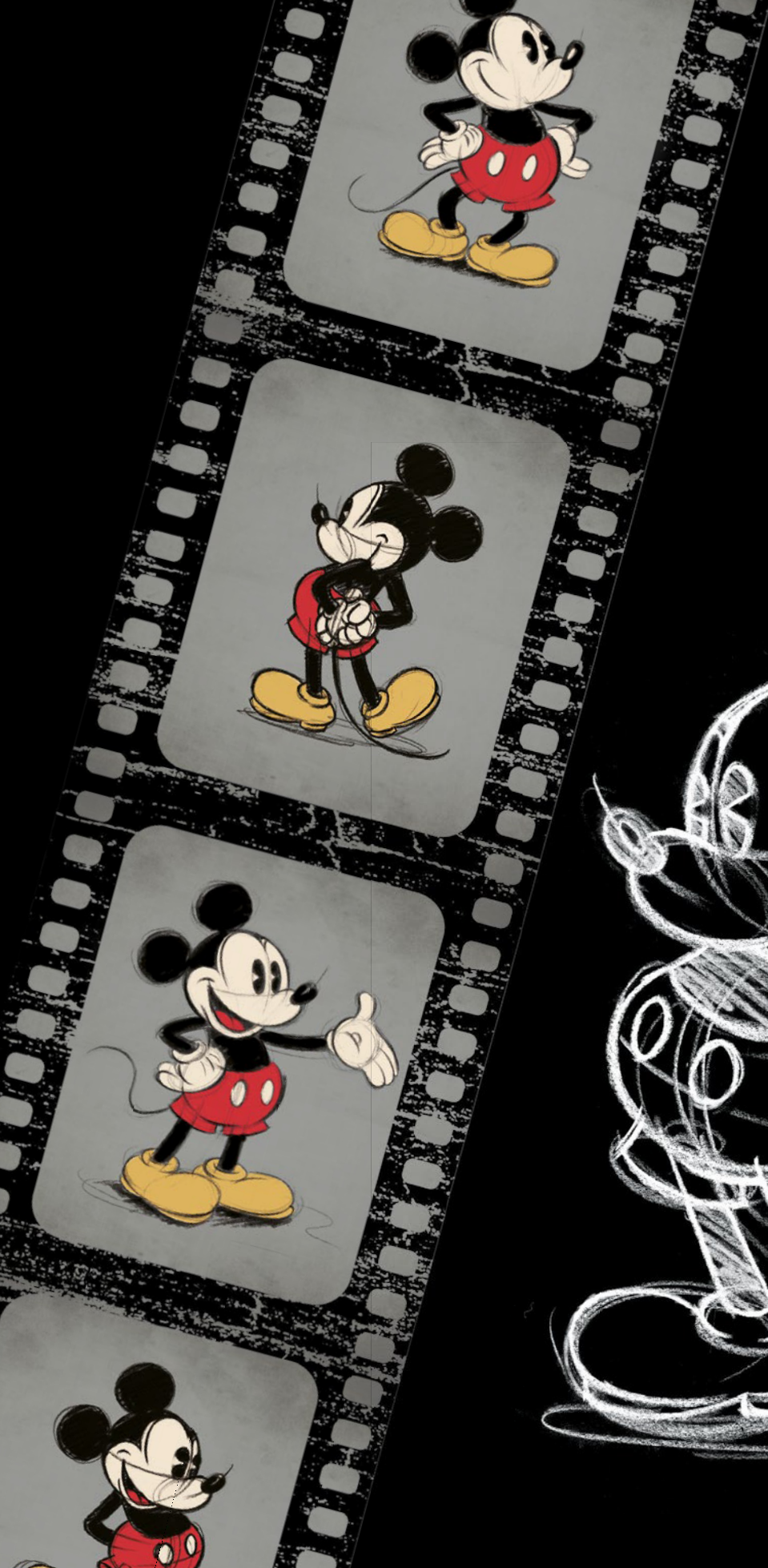

NOTES FROM THE DESIGNER REMARQUES DU CONCEPTEUR NOTAS DEL DISEÑADOR

Ollie Gregory – LEGO® Disney Designer

FROM IDEA TO SHELF

I want to design things that I'd like to put on my shelf, so I always visualize people's homes when I work. How does the set integrate into someone's study or living room? That's why we went with the 'classic' Mickey design, with his iconic silhouette and color palette.

DE L'IDÉE À L'ÉTAGÈRE

Je veux créer des choses que j'aimerais moi-même exposer sur mon étagère. C'est pourquoi je visualise toujours les maisons des gens lorsque je travaille. Comment l'ensemble s'intègre-t-il dans un bureau ou dans un salon ? C'est pourquoi nous avons choisi le design « classique » de Mickey avec sa silhouette et ses couleurs emblématiques.

DE LA IDEA AL ESTANTE

Me gusta diseñar cosas que yo mismo pondría en mi estante, así que siempre imagino los hogares de la gente cuando trabajo. ¿Cómo se integrará el set en el estudio o la sala de alguien? Por eso elegimos el diseño "clásico" de Mickey, con su inconfundible silueta y su paleta de colores.

MY FAVORITE BITS

I really like that we're using the classic LEGO® space helmet for Mickey's nose. There are a few Easter eggs like that, Mickey's shorts (which are barrels) or his mouth (a wheel arch) to name a few. We also developed this great new tubular shape for the arms and legs to capture the original animation style of those early Disney shorts.

MES ÉLÉMENTS PRÉFÉRÉS

J'aime vraiment le fait que nous utilisons le casque spatial LEGO® classique pour représenter le nez de Mickey. Sa conception présente d'autres surprises, comme le short de Mickey (qui est fait avec des barils) ou sa bouche (un passage de roue), pour ne nommer que celles-là. Nous avons également créé une nouvelle forme tubulaire pour ses bras et ses jambes afin de bien représenter le style original des premiers films d'animation de Disney.

MIS PARTES FAVORITAS

Me encanta que hayamos usado el clásico casco espacial LEGO® como nariz de Mickey. Hay unos cuantos huevos de Pascua como ese; en los pantalones de Mickey (que son medios barriles) o la boca (una salpicadera), por ejemplo. También desarrollamos una nueva forma tubular genial para los brazos y las piernas que nos permitió capturar el estilo original de los primeros cortos de animación de Disney.



THE TRICKY PART

The biggest challenge we faced was the weight distribution, because Mickey carries most of his weight in the head and the body. The model needed reinforcement in the legs, feet and base to get him to stand right. That was a mini feat of engineering for us.



LE PRINCIPAL DÉFI

Le plus grand défi que nous avons dû relever était la répartition du poids, car le poids de Mickey est principalement réparti dans sa tête et dans son corps. Le modèle avait besoin de renfort dans les jambes, les pieds et la base pour qu'il puisse se tenir debout. Nous avons finalement relevé ce mini défi d'ingénierie.

LO MÁS COMPLICADO

El mayor reto al que nos enfrentamos fue la distribución del peso, porque Mickey lo concentra casi todo en la cabeza y el cuerpo. El modelo necesitaba refuerzos en las piernas, los pies y la base para tenerse en pie. Para nosotros fue una minihazaña de ingeniería.

Lauren Cullen King – LEGO® Graphic Designer
Yoel Mazur – LEGO Element Designer





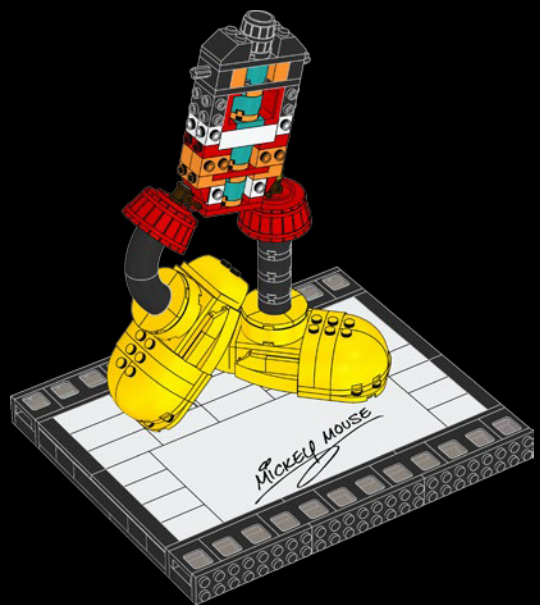
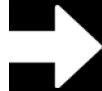
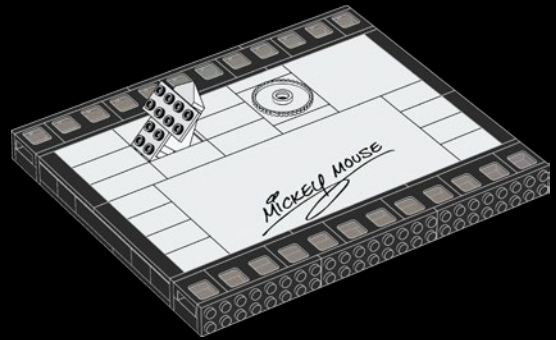

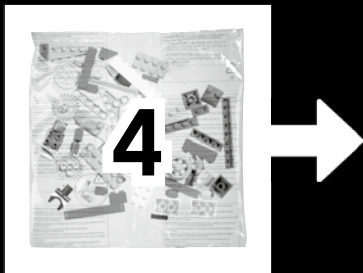
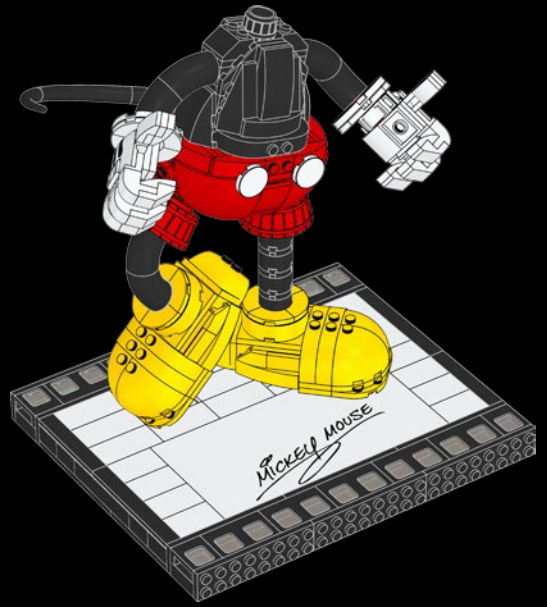
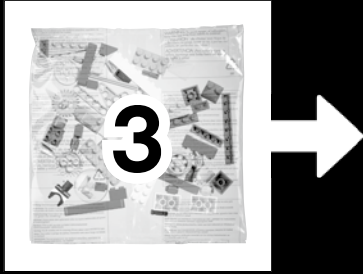

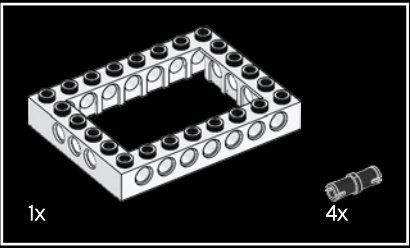
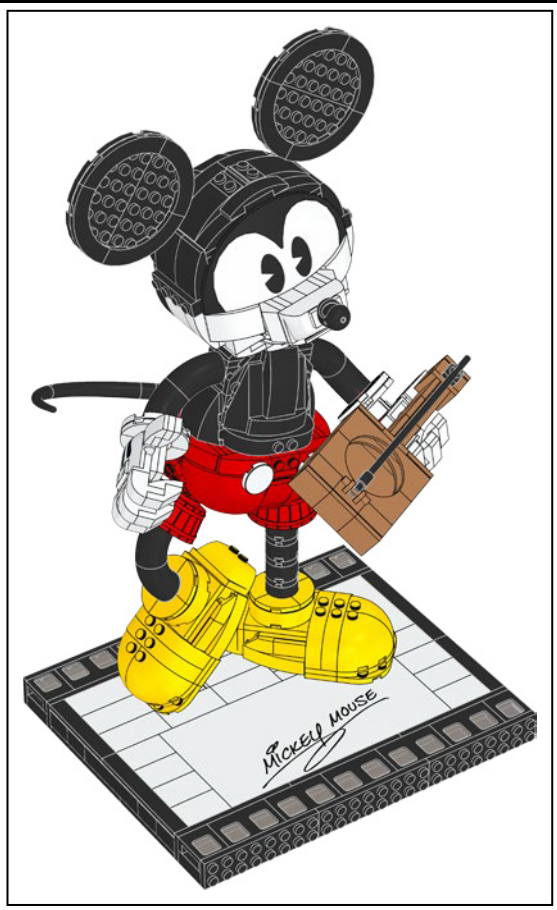
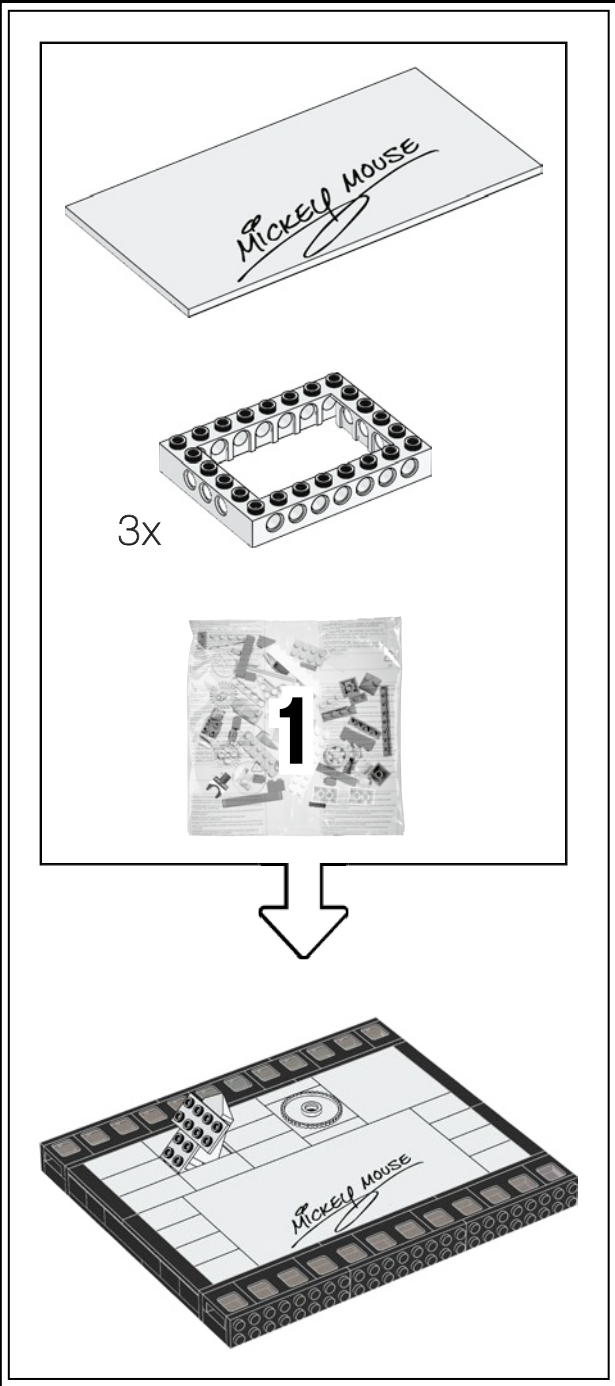

1

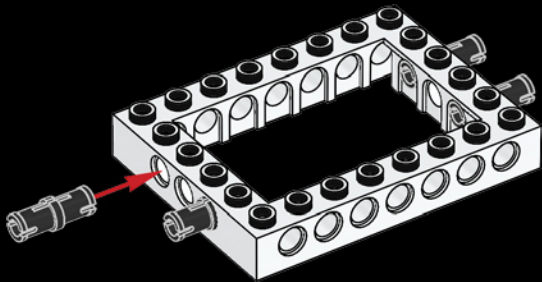

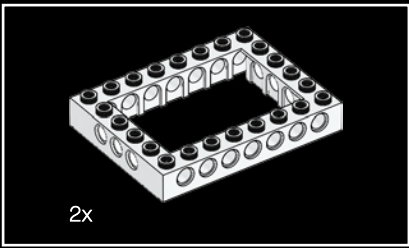

2

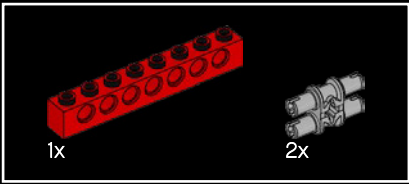
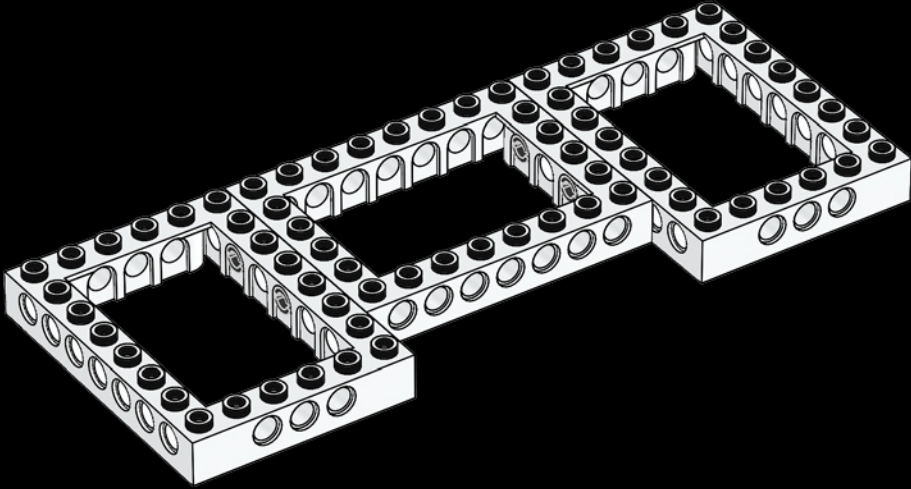

3

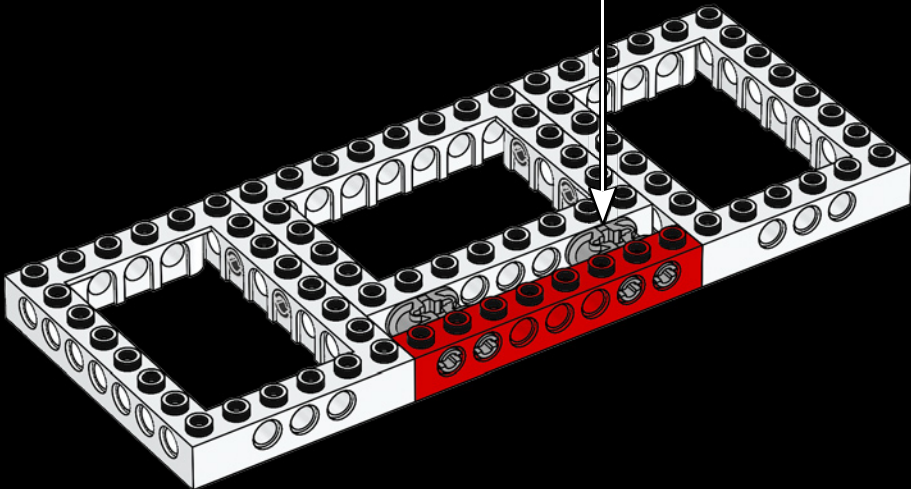
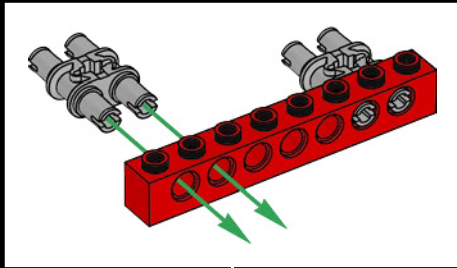

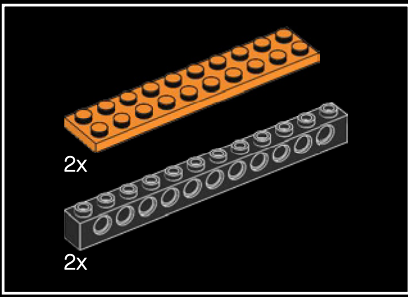

4

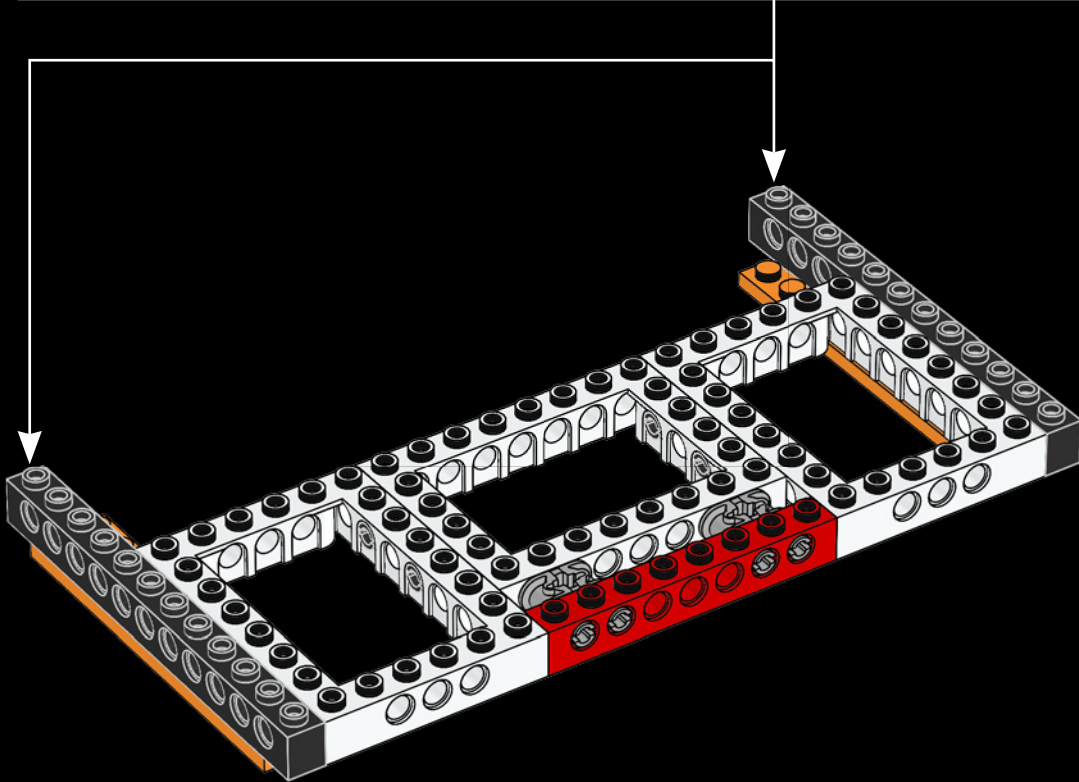
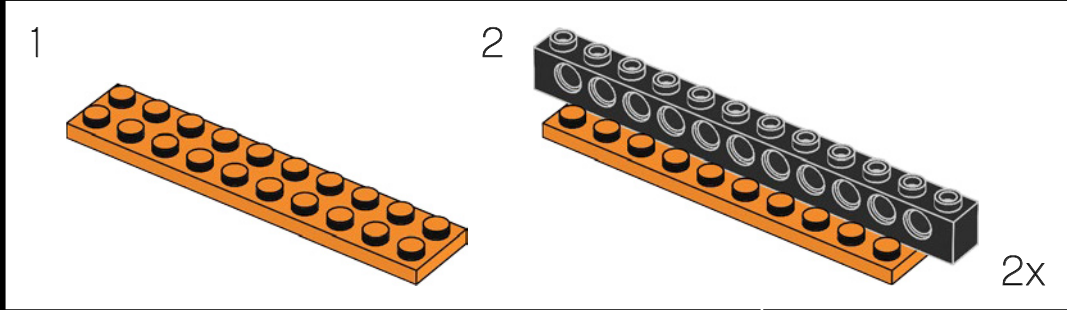

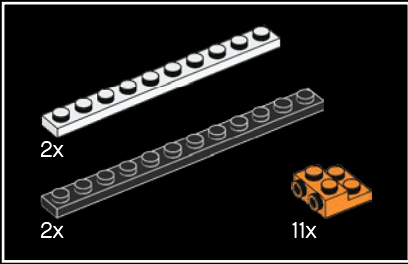
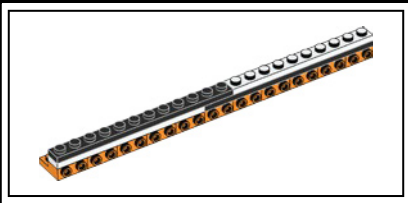

5

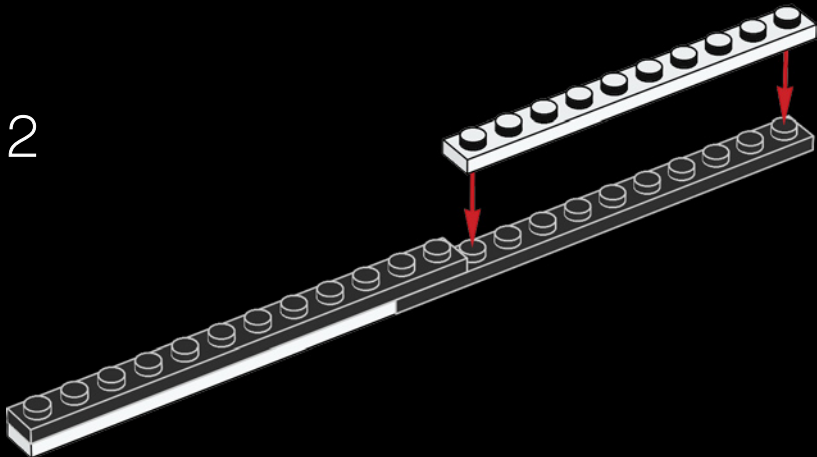
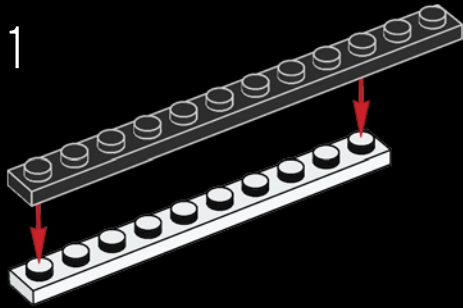



3

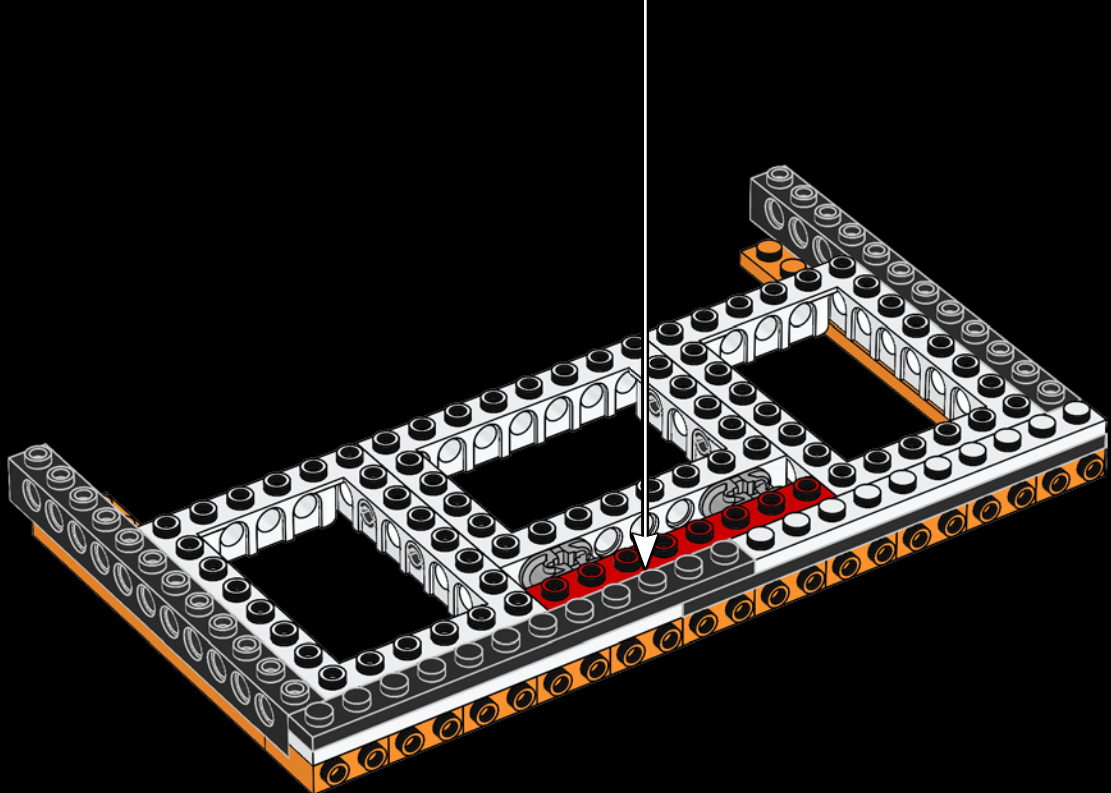
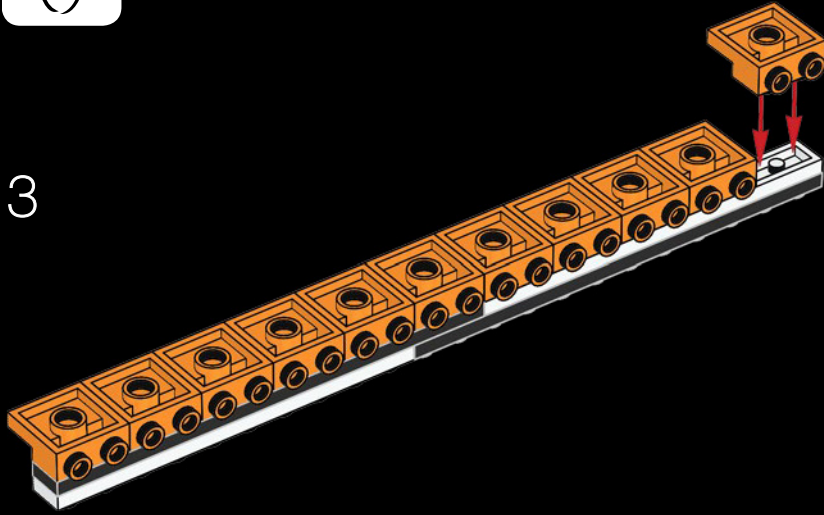

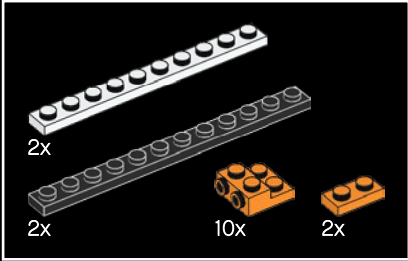
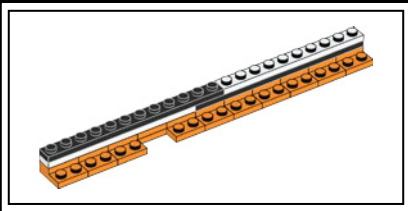

6

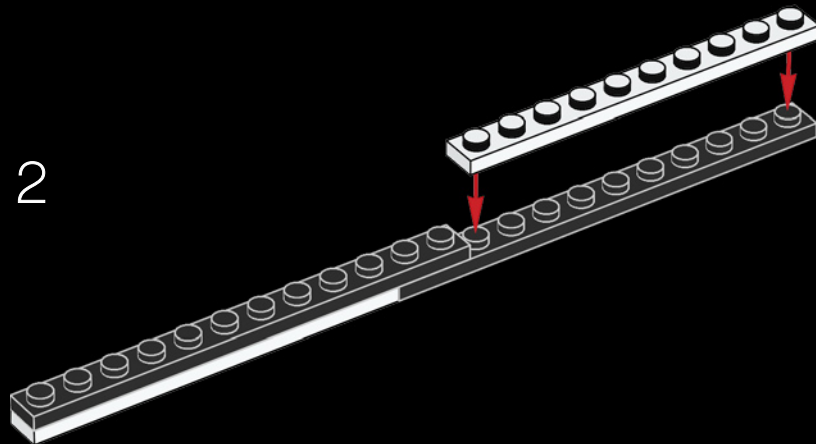
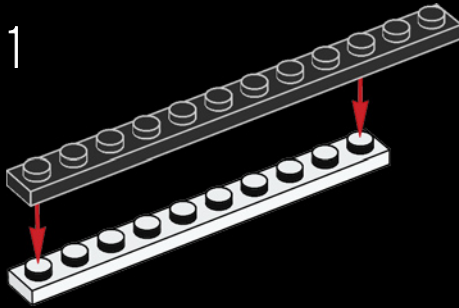



3

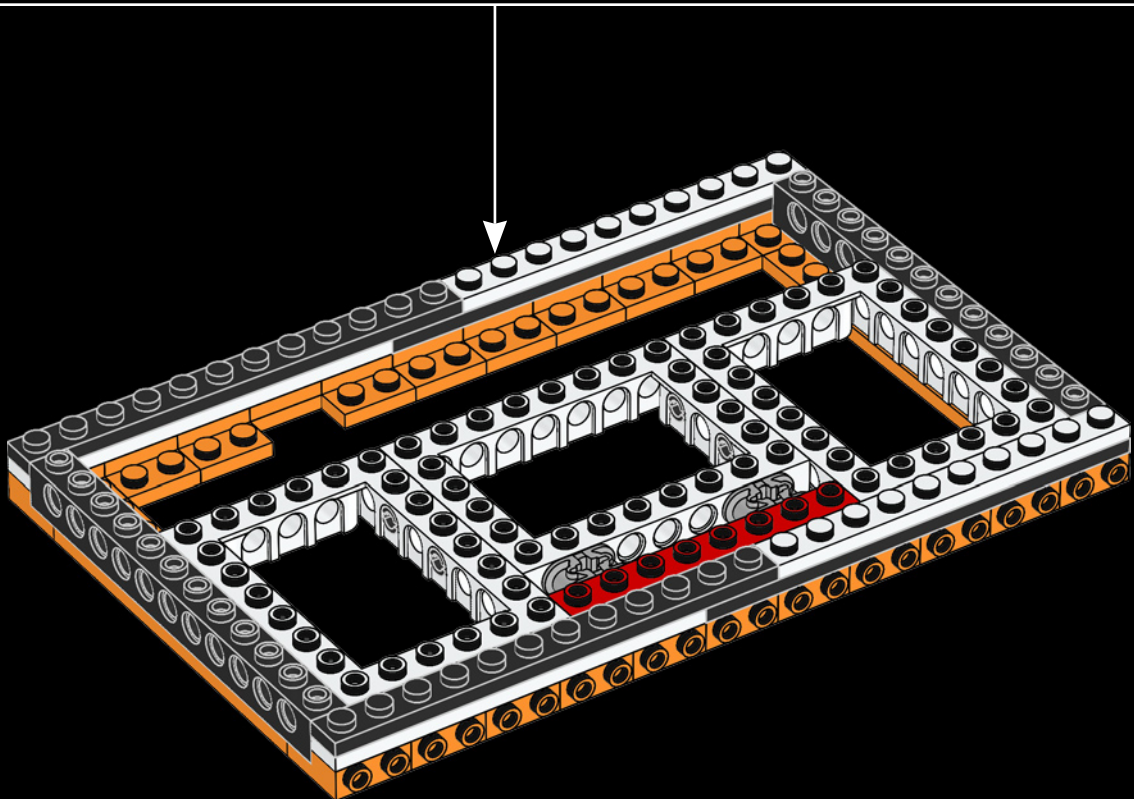
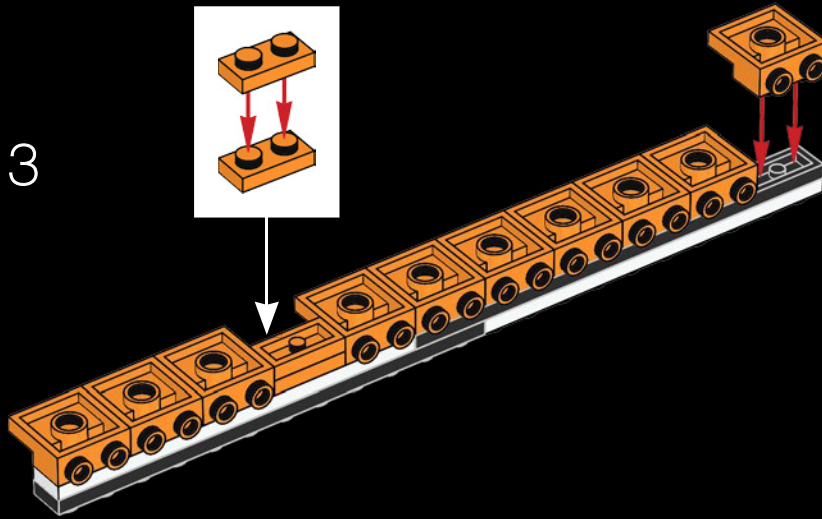
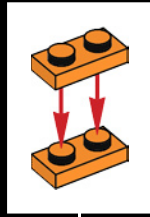

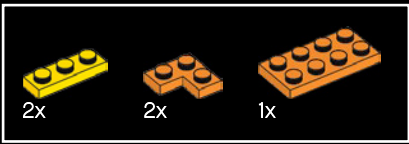

7

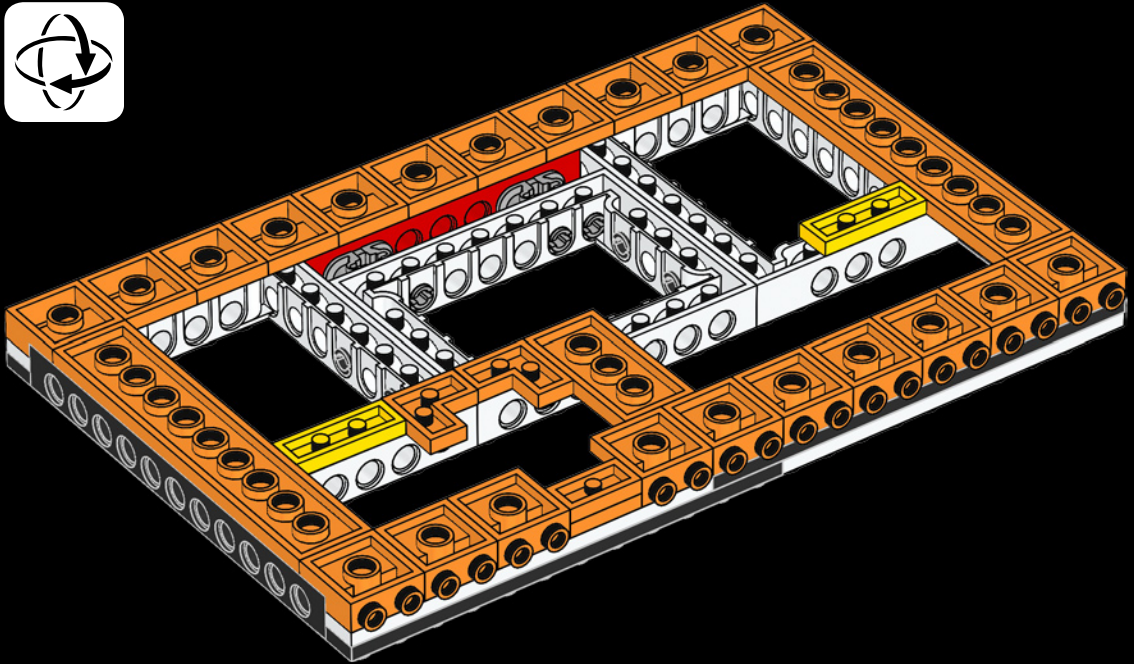

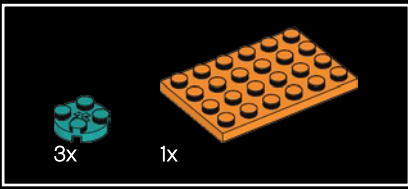

8

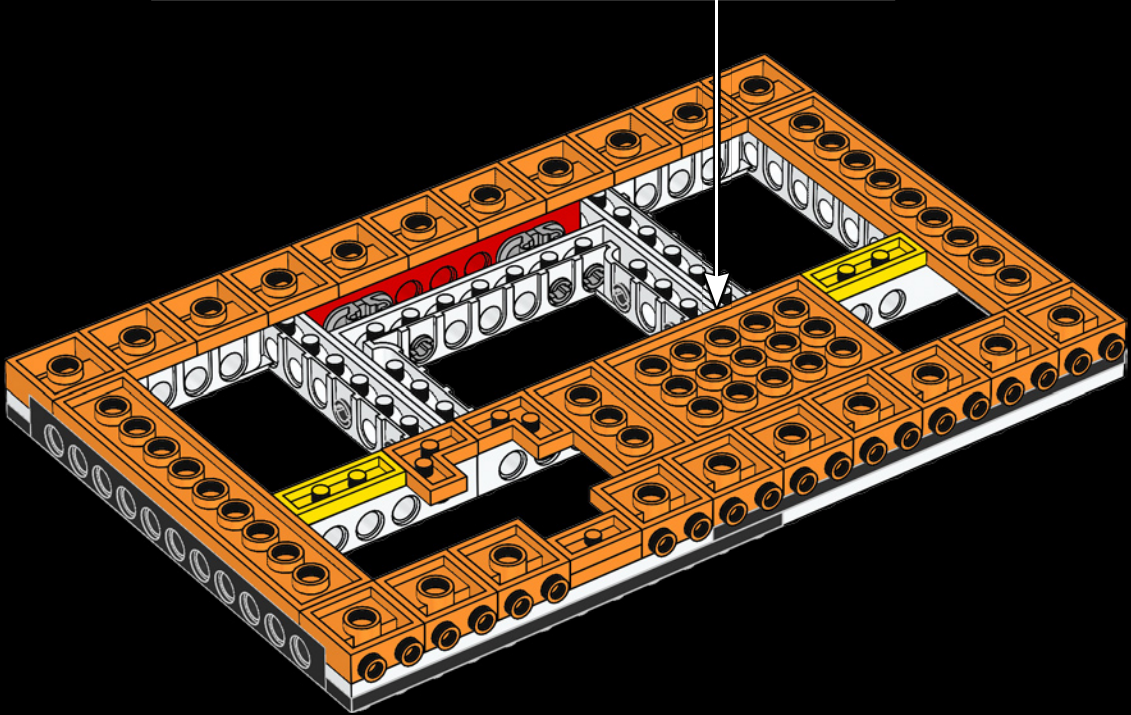
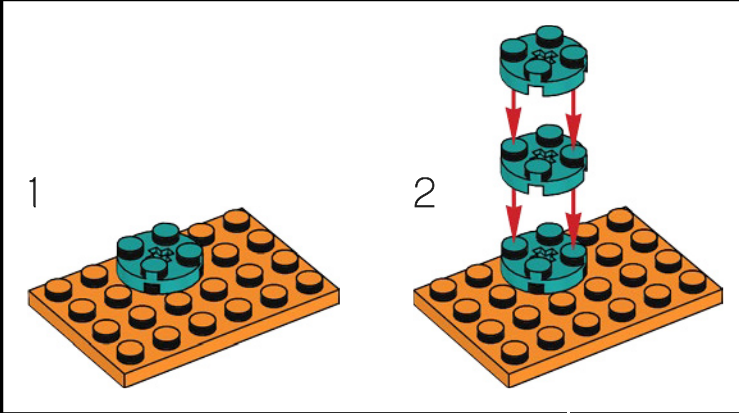

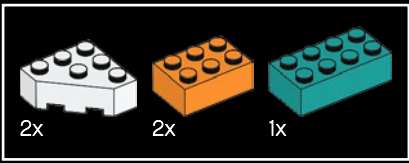

9

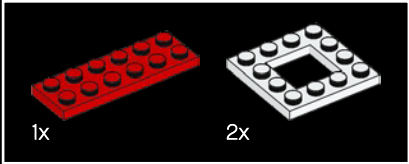
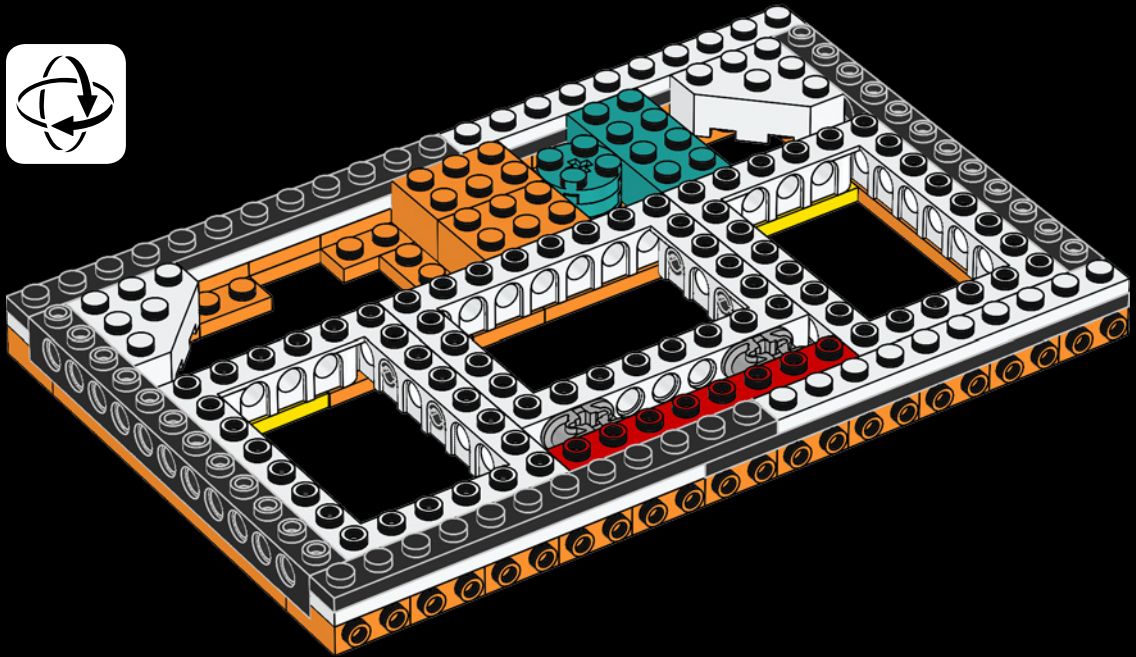

10

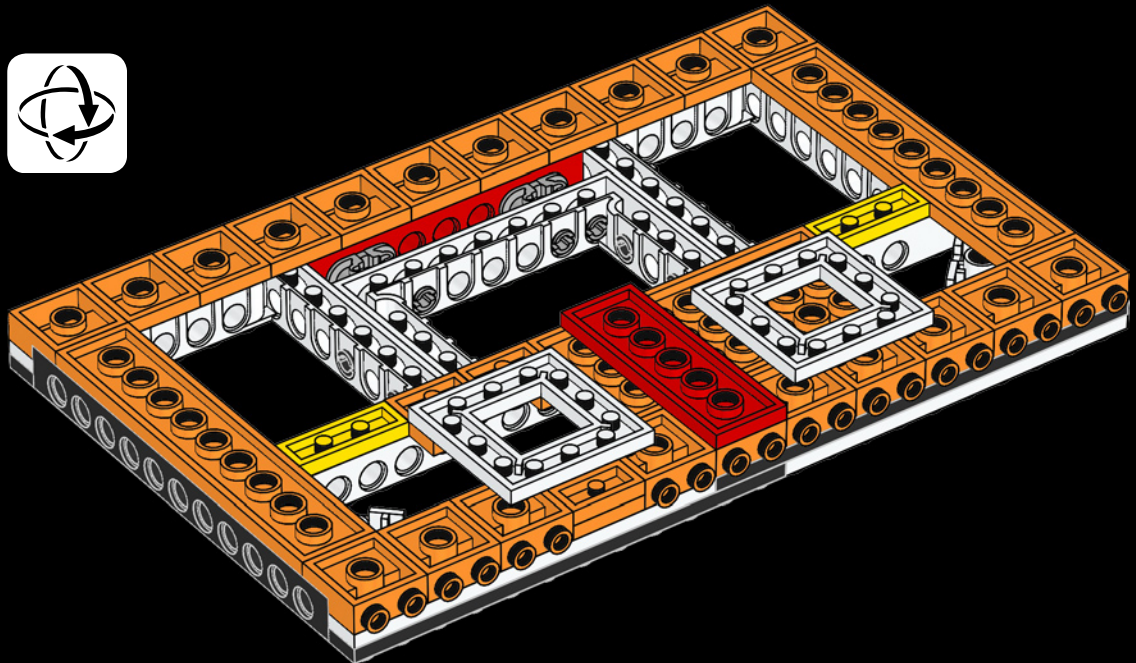

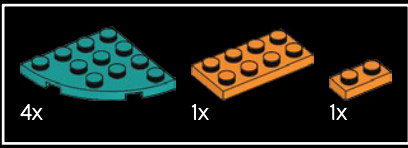

11

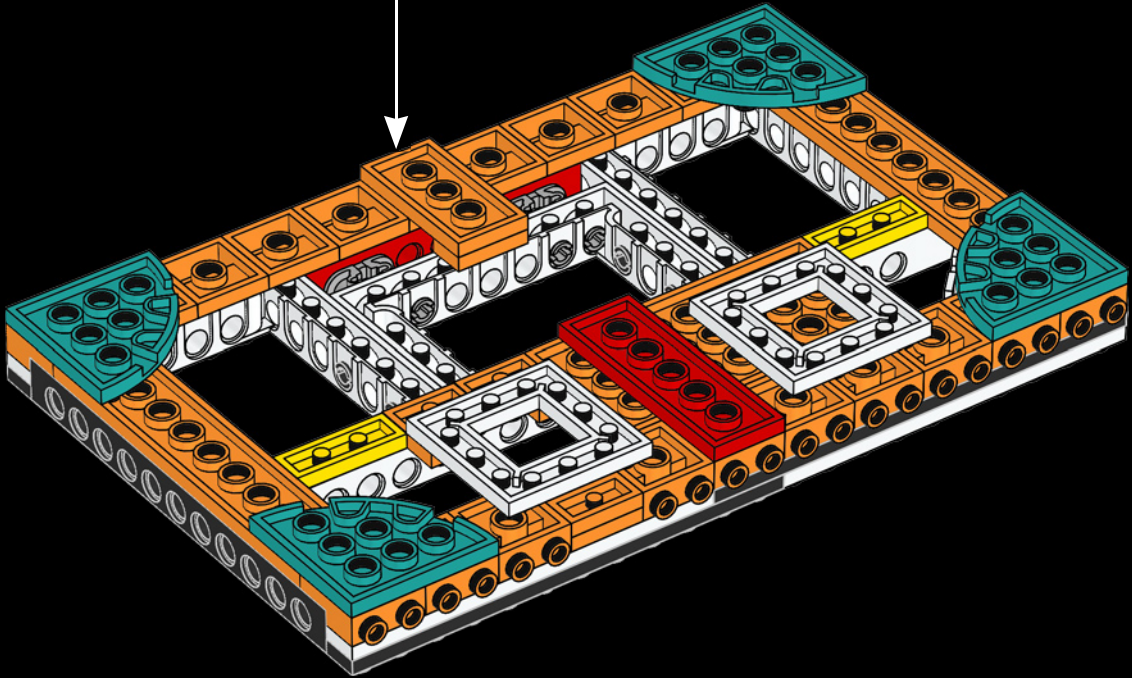
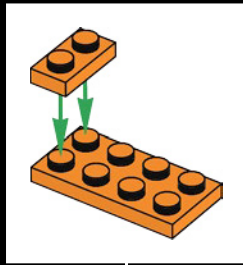

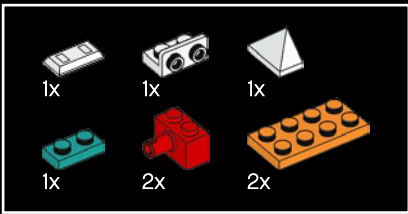

12

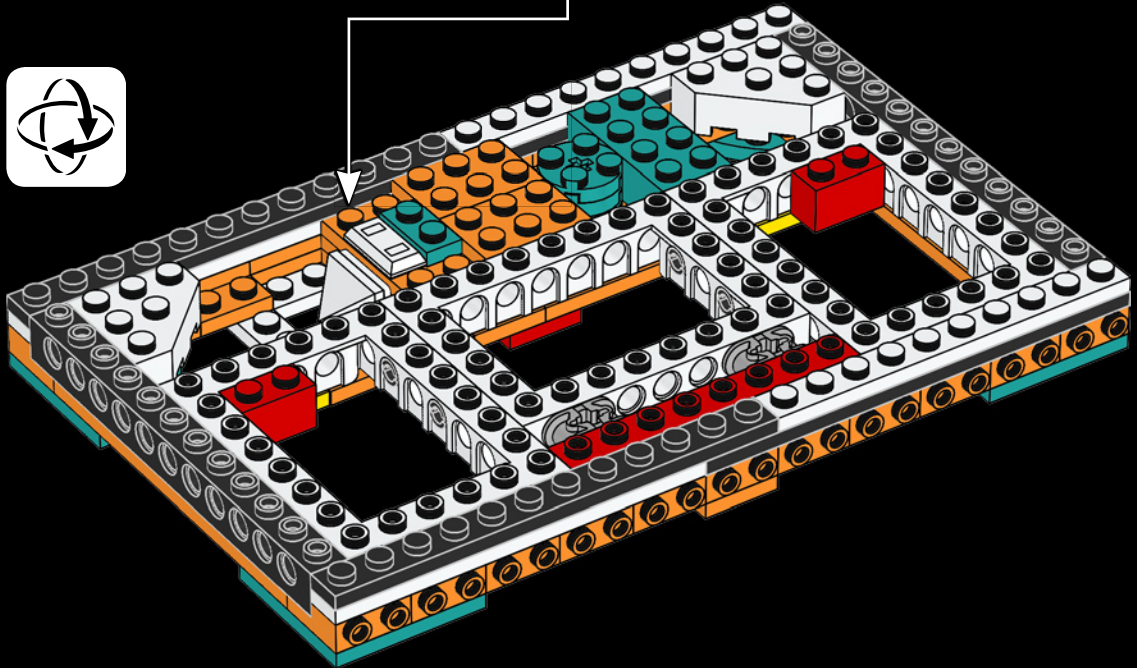
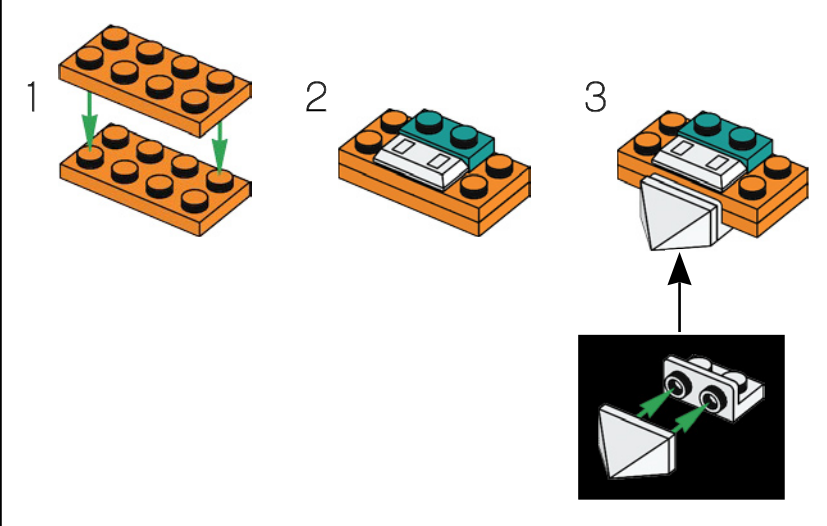

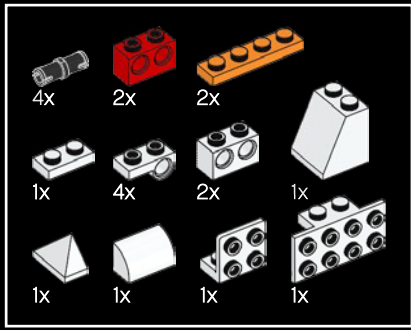

13

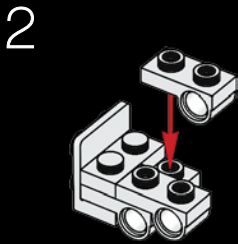
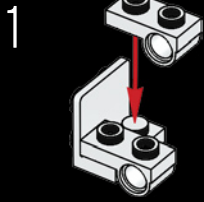

3

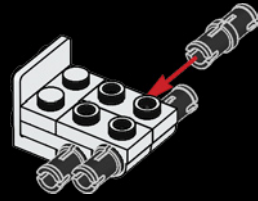

4



5

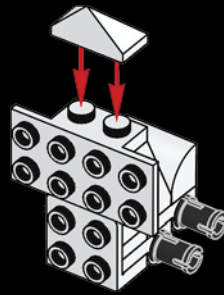

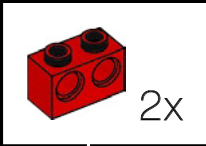

6

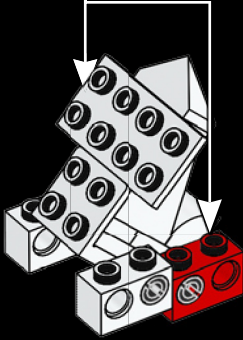

7

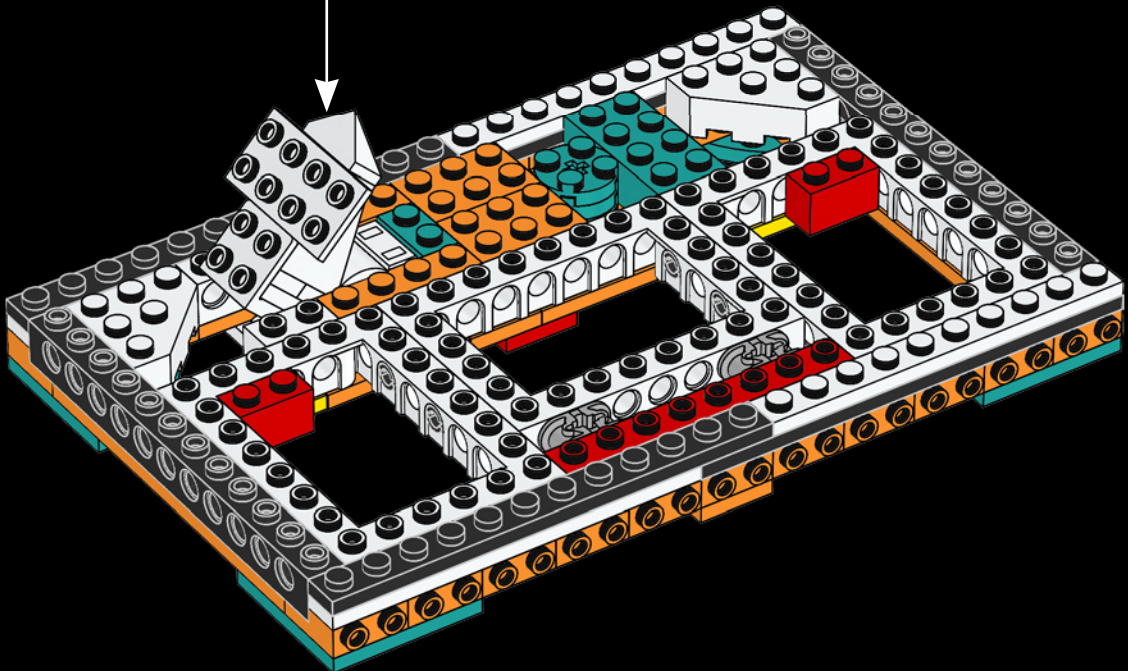
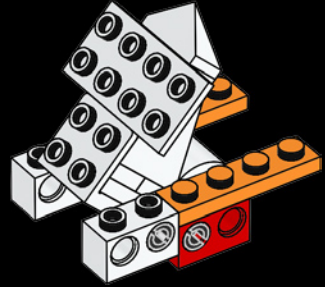

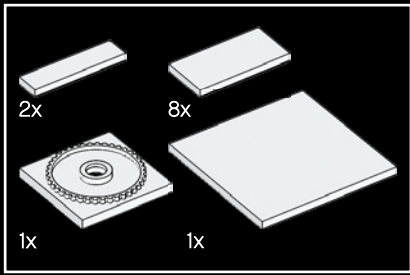

14

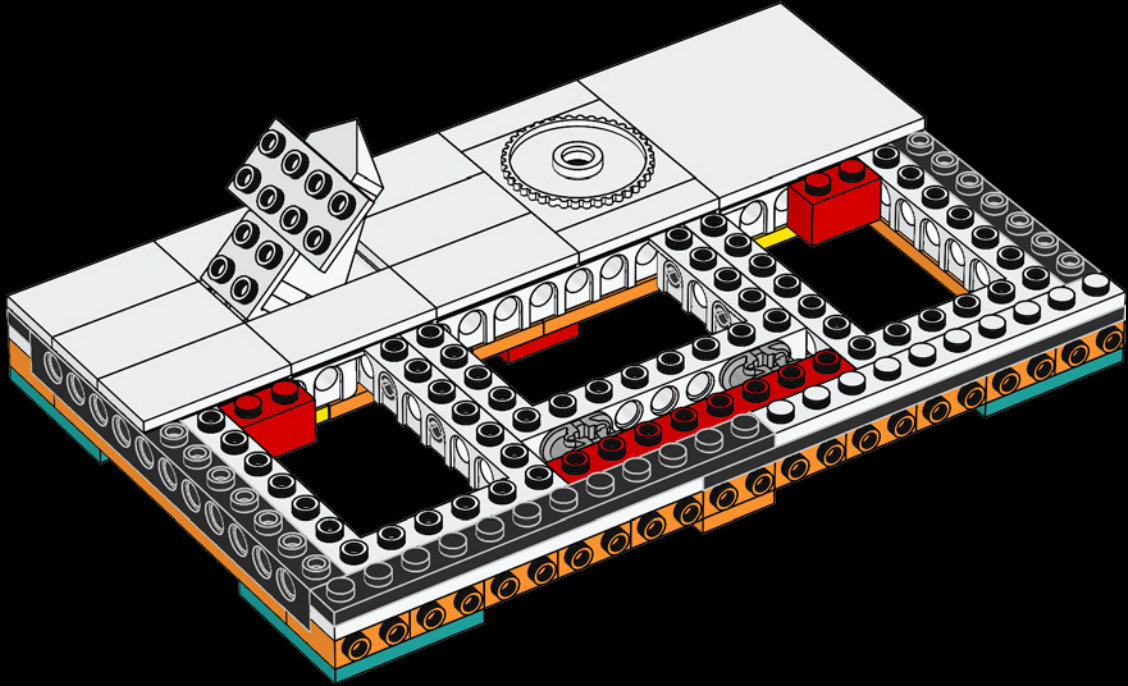

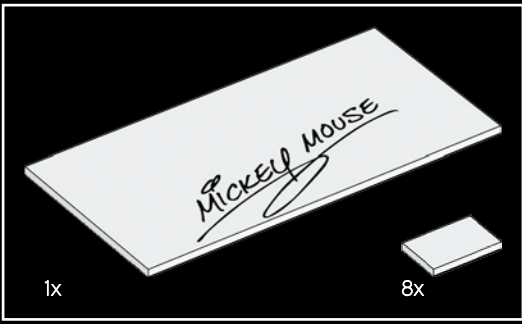

15

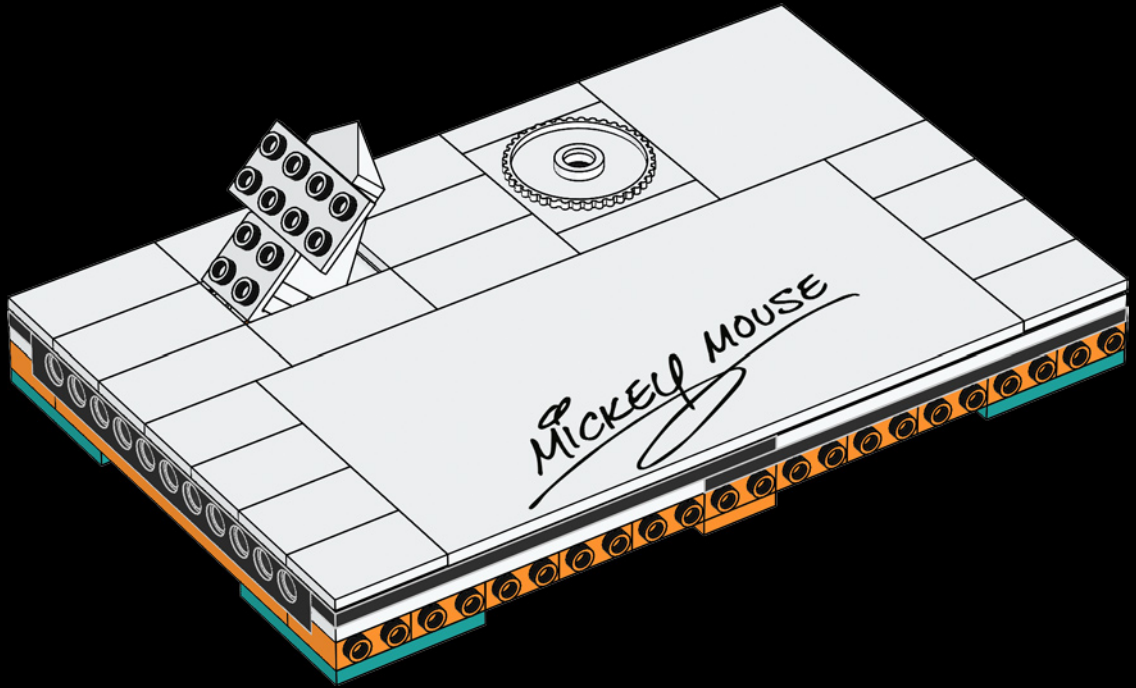

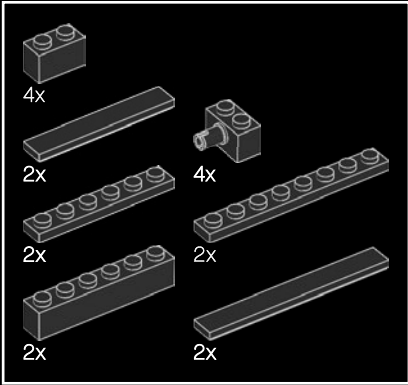
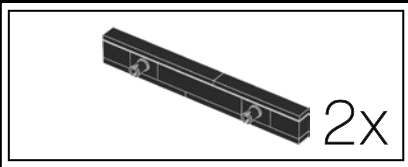

16

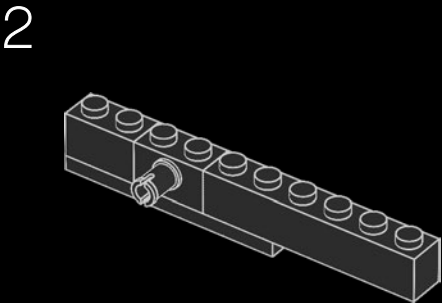
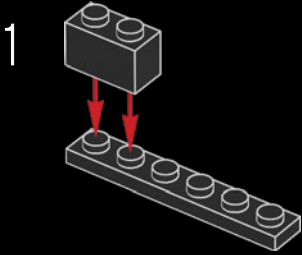

3

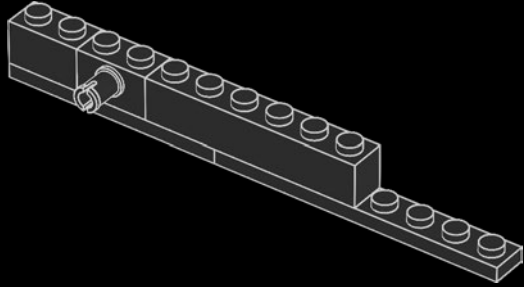

4

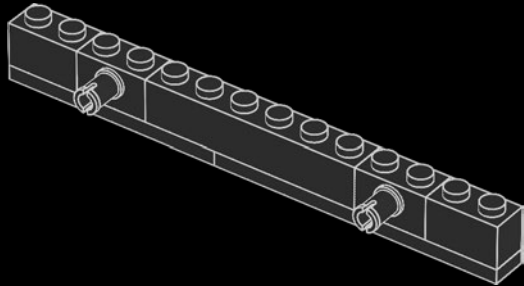

5

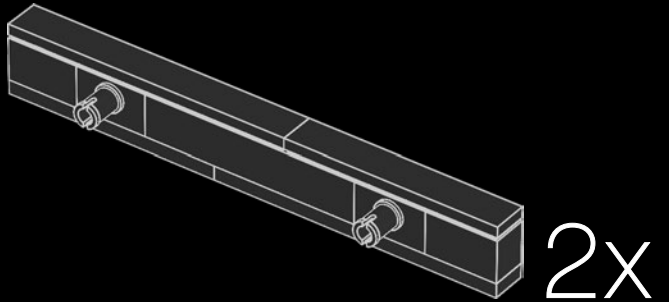

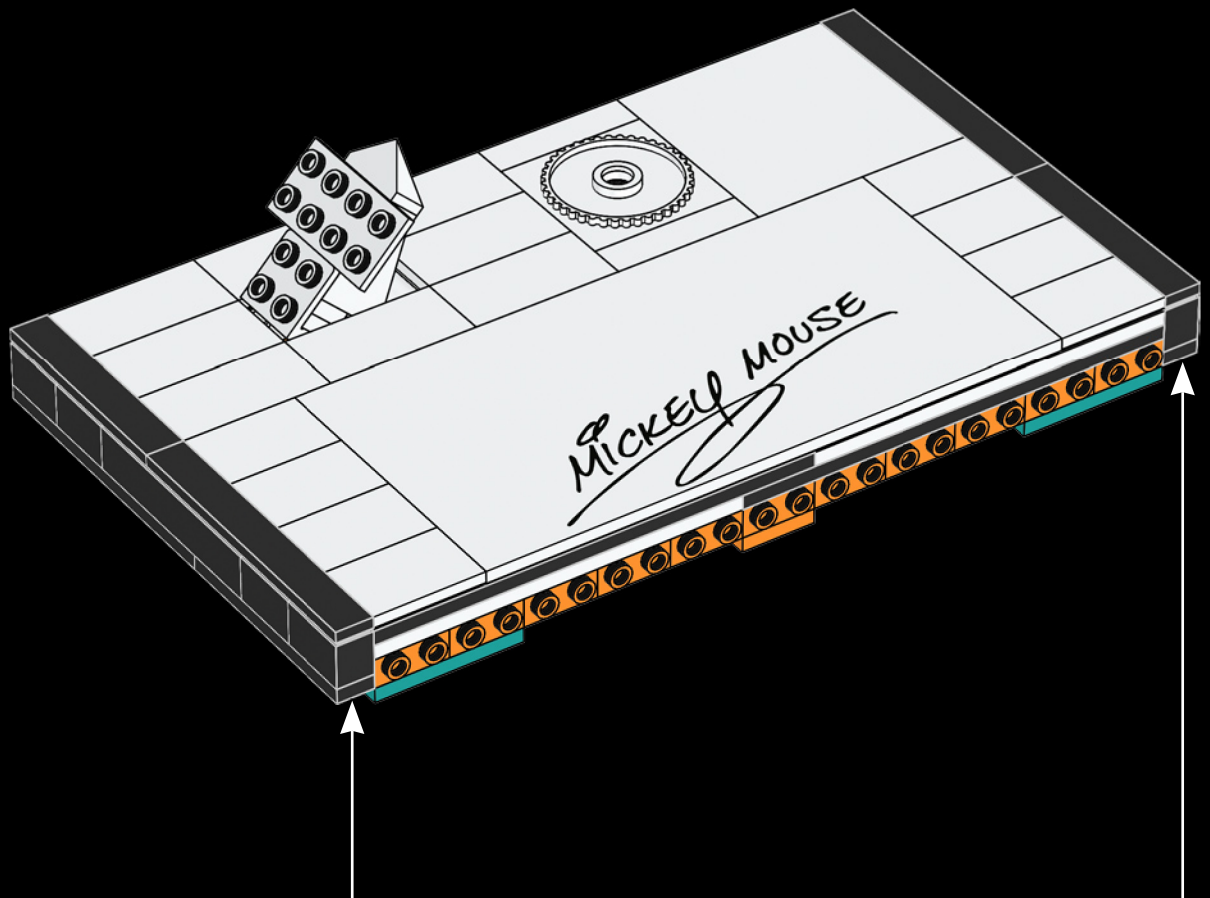

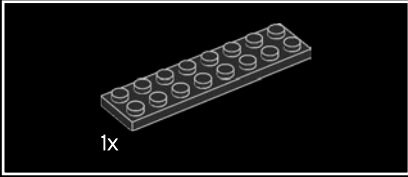
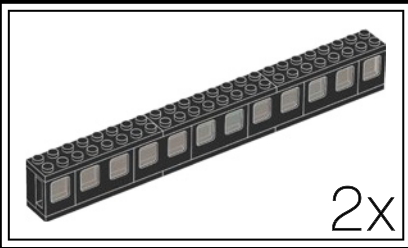

17

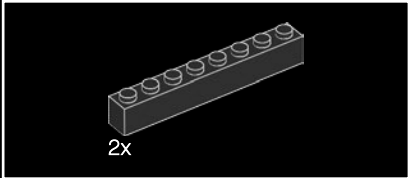
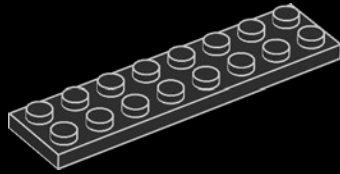

18

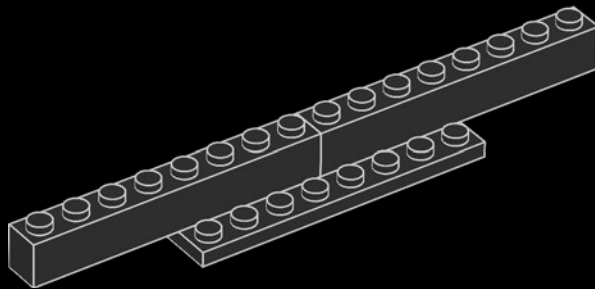

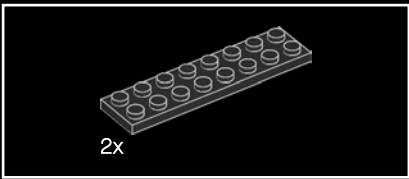

19

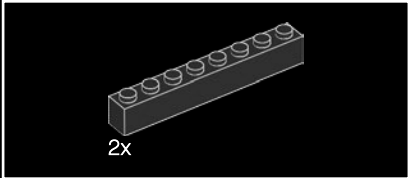
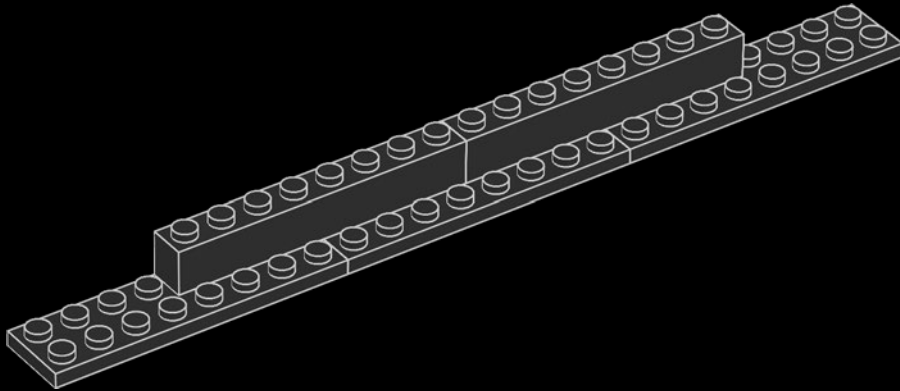

20

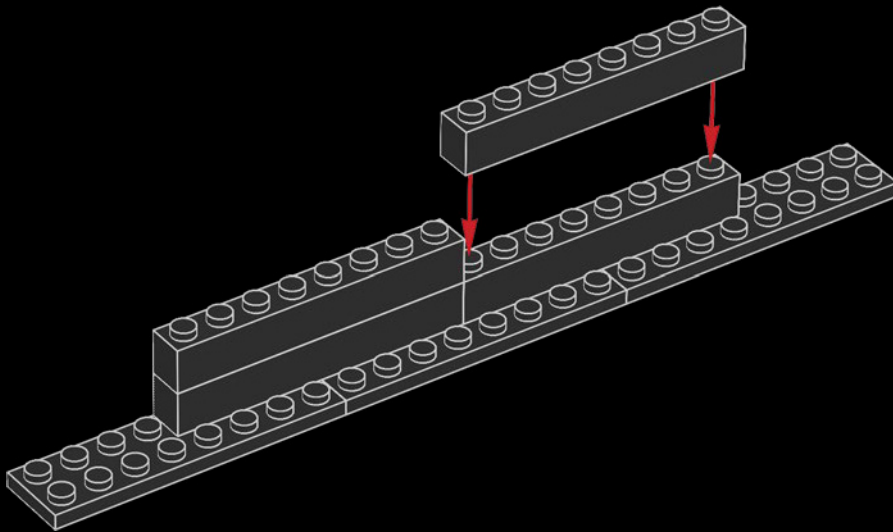

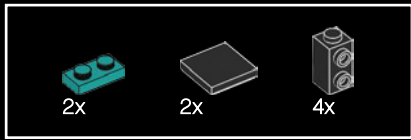

21

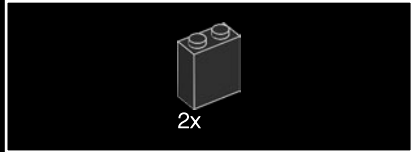
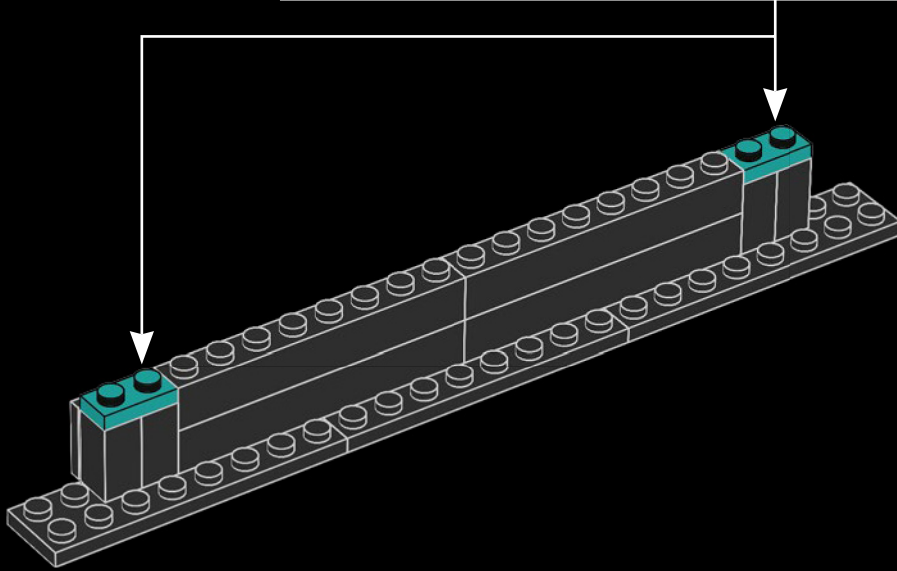
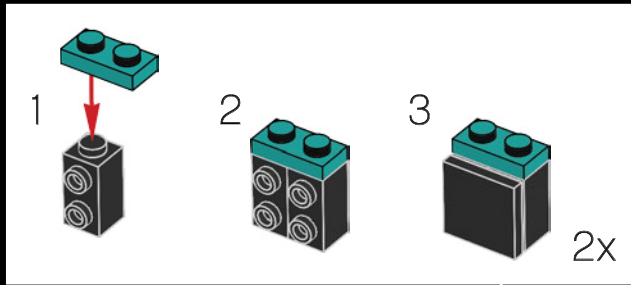

22

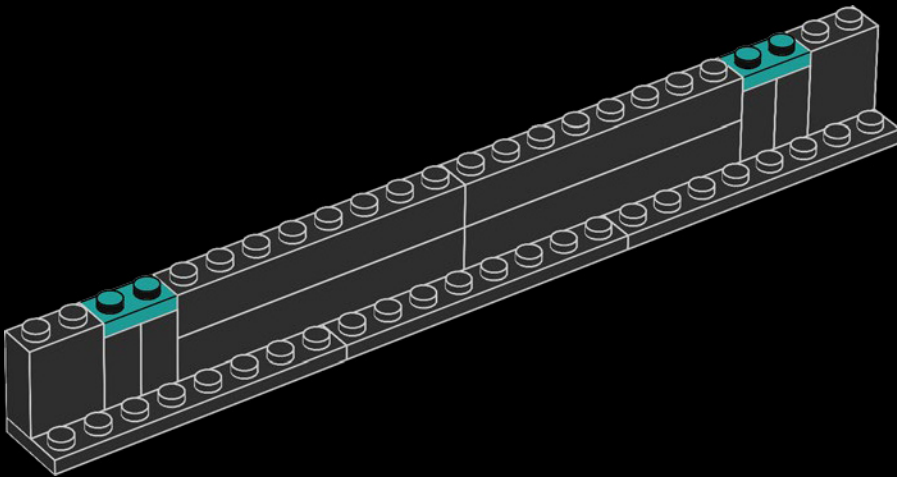

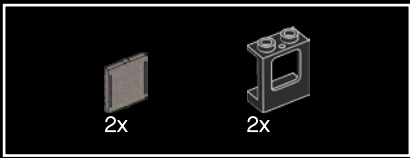

23

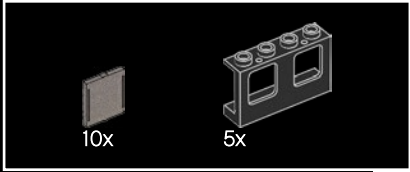
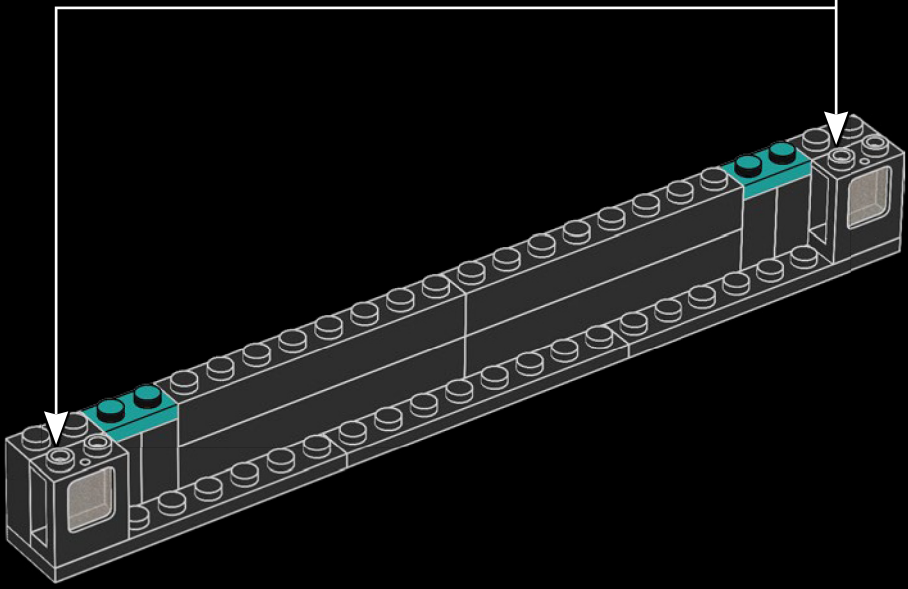
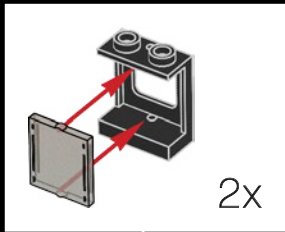

24

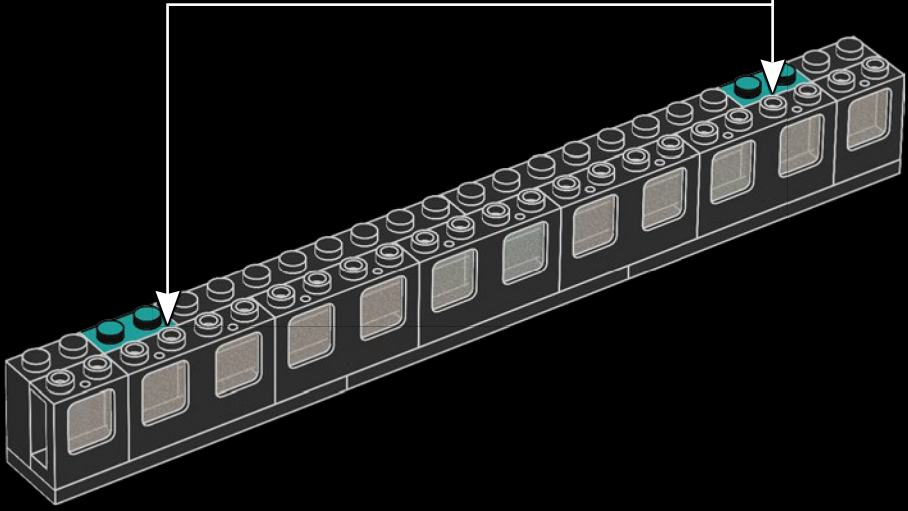
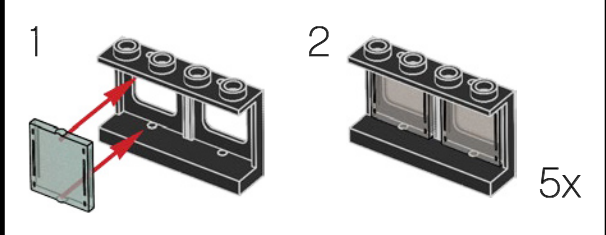

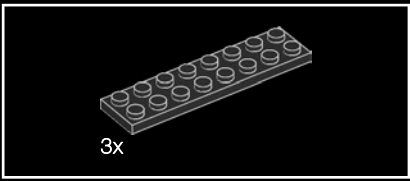

25

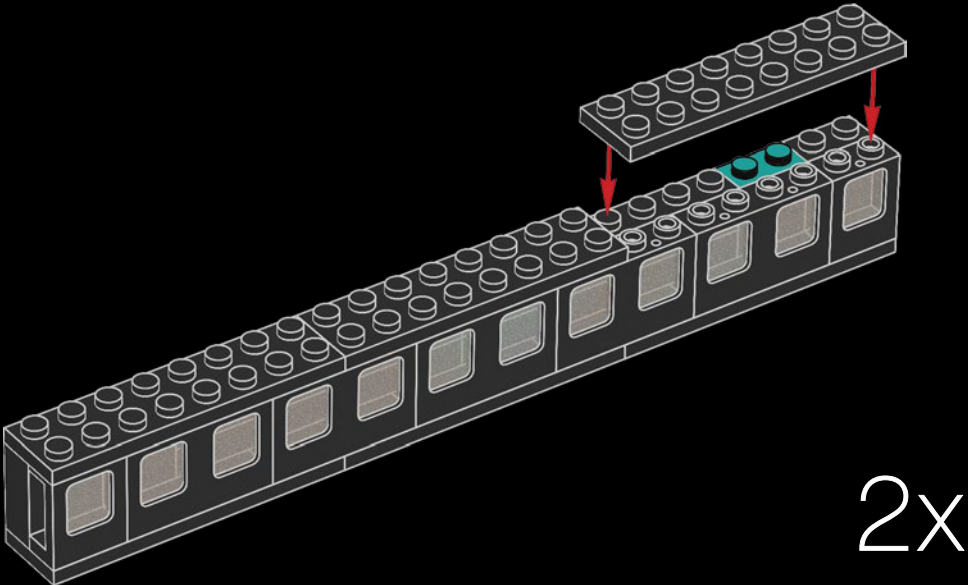

26

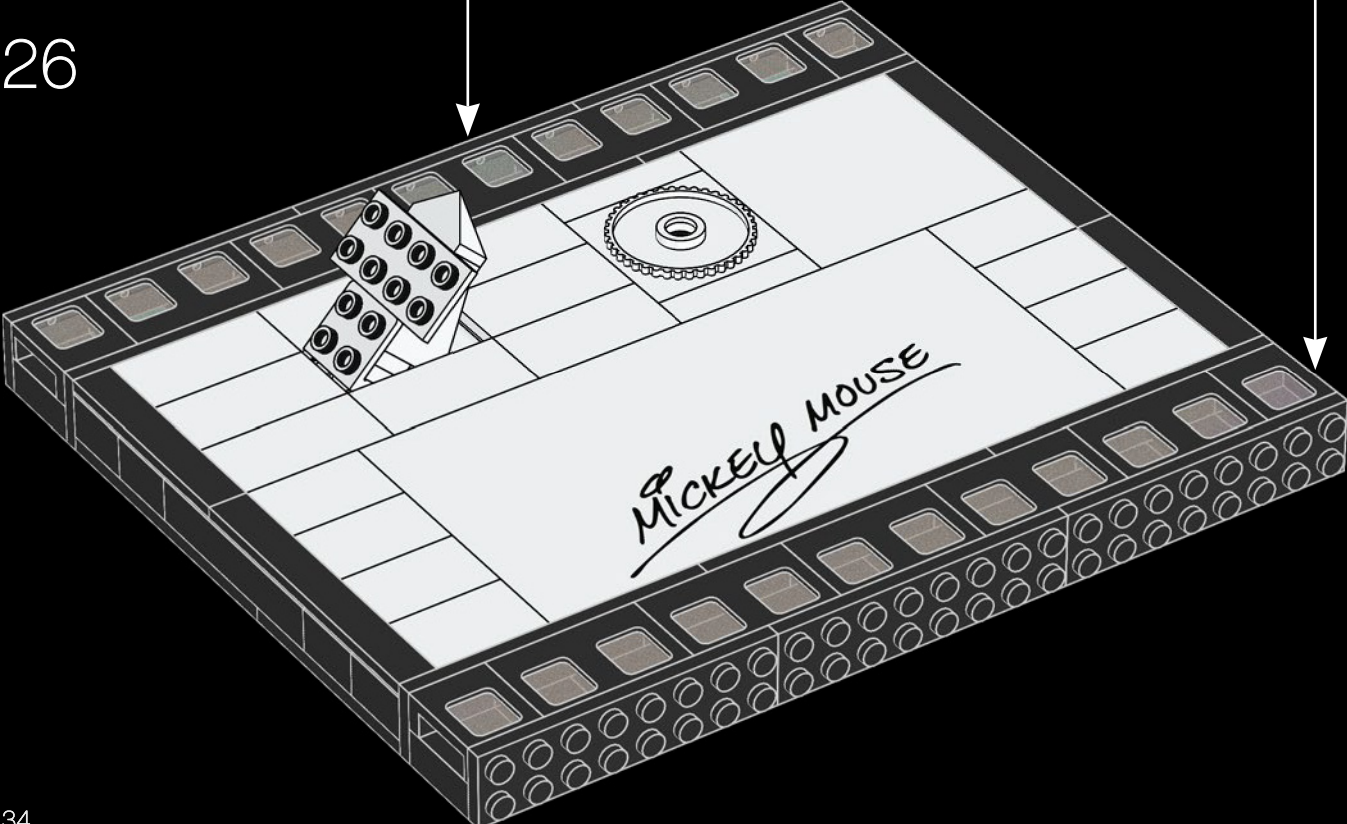

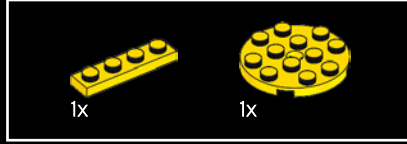
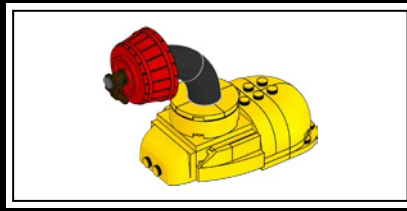
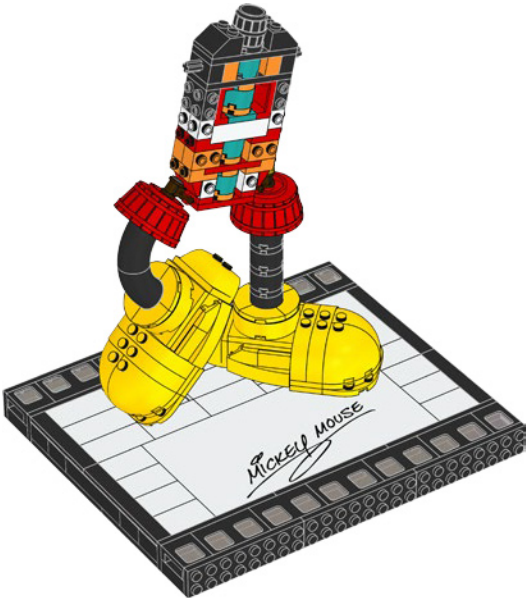

27

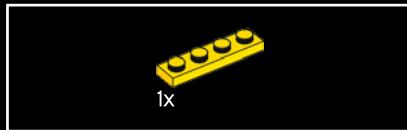
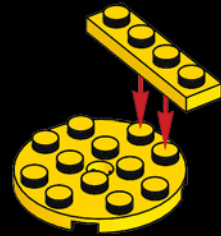

28

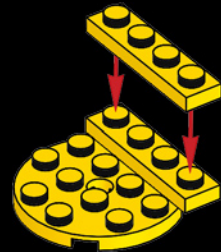

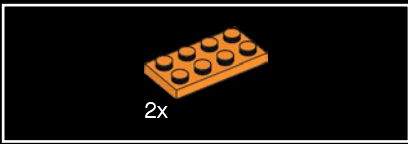

29

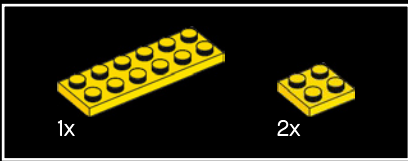
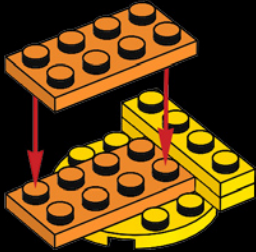

30

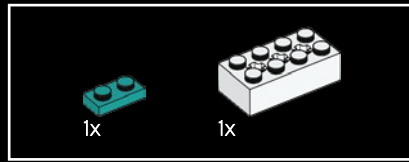
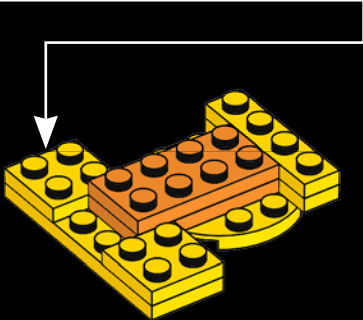
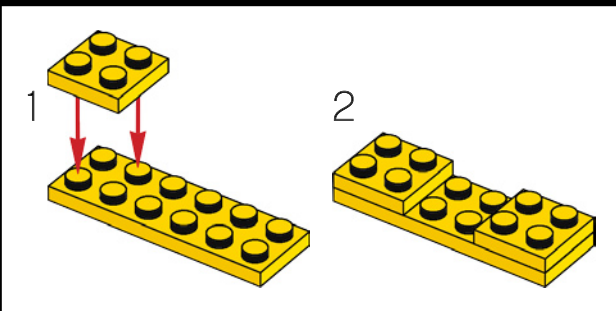

31

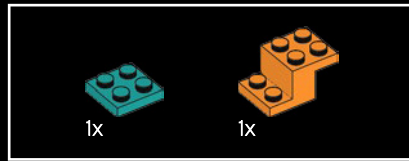
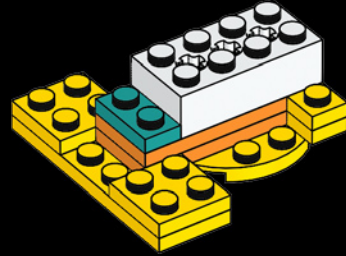

32

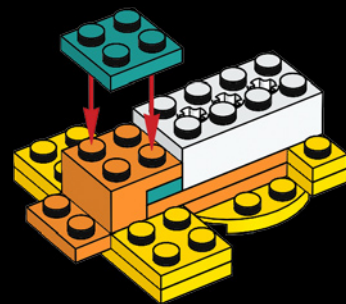

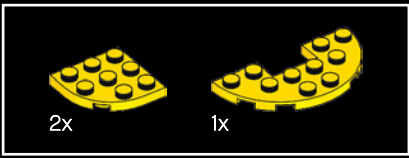

33

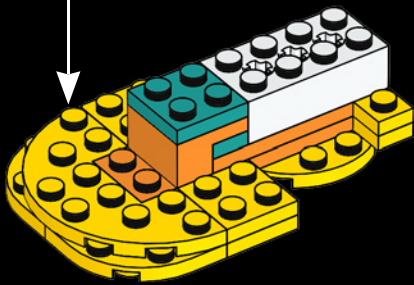
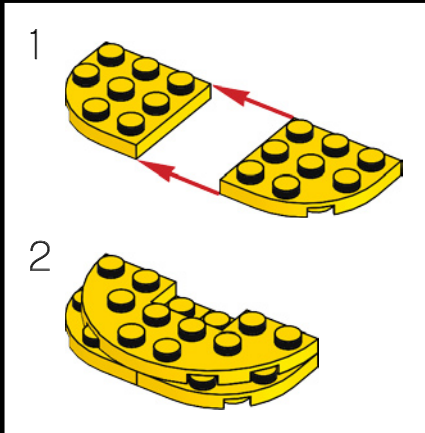

34

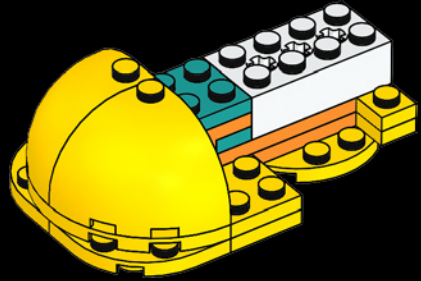

35

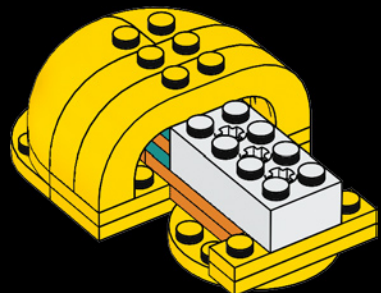

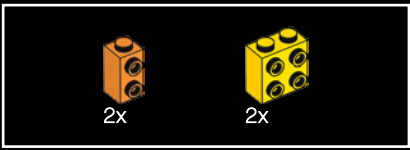

36

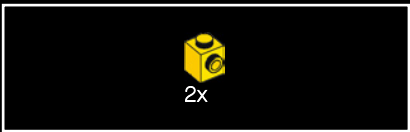
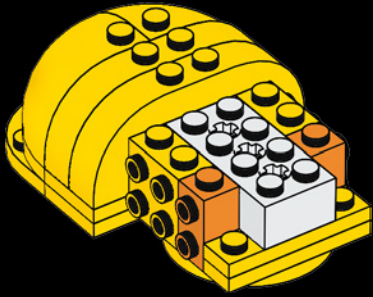

37

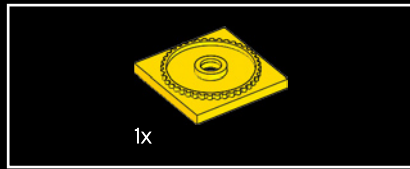
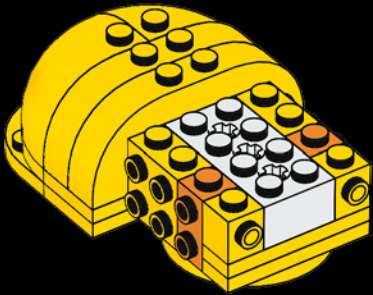

38

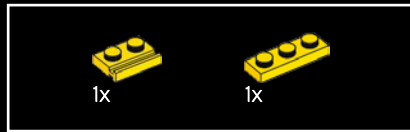
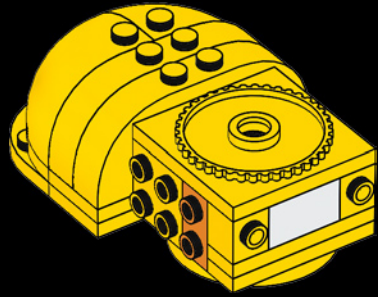

39

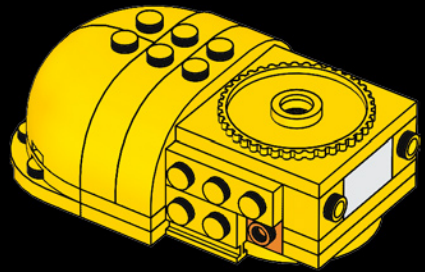

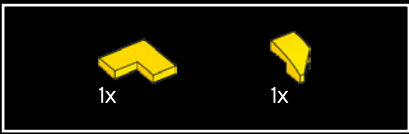

40

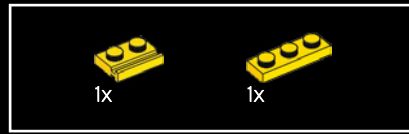
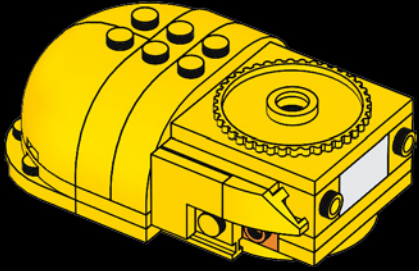

42

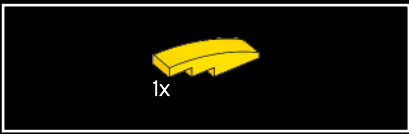
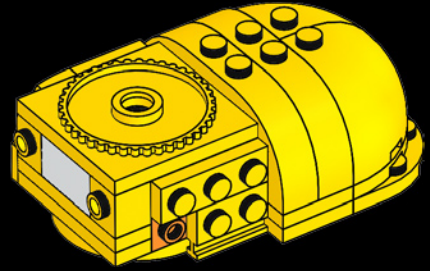

41

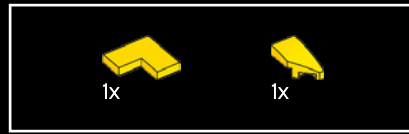
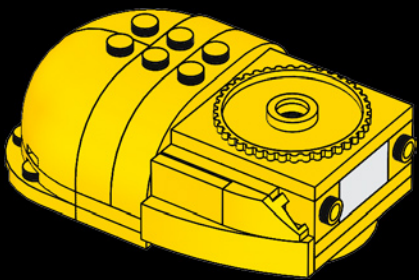

43

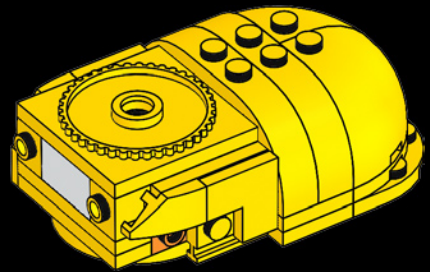

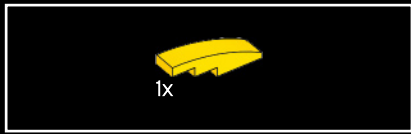

44

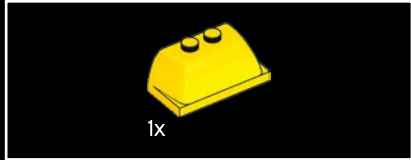
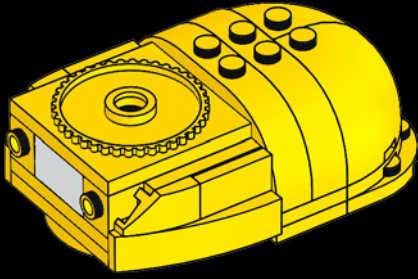

45

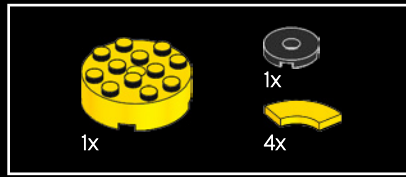
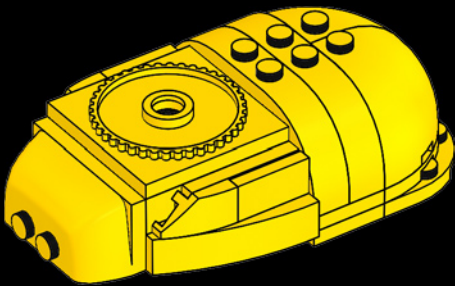

46

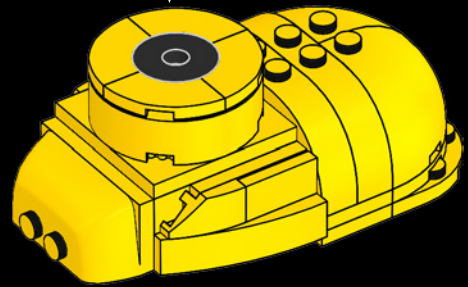
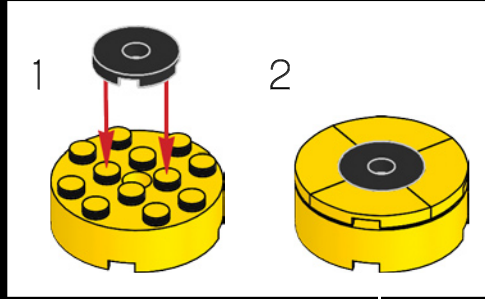

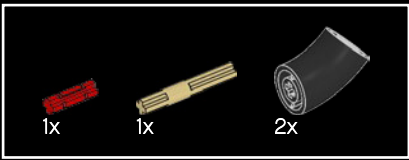

47

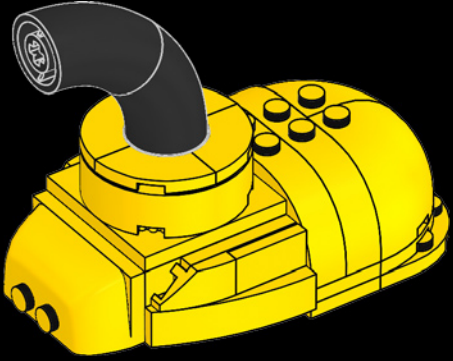
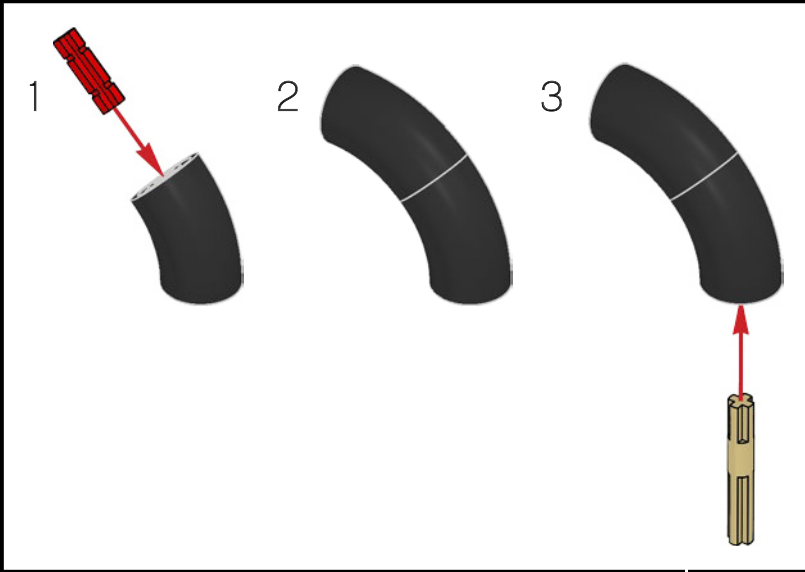

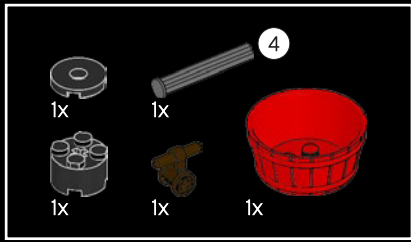

48

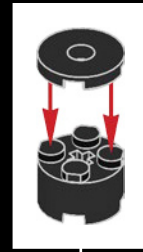
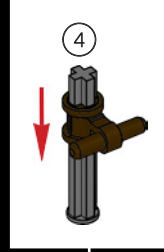

1



2

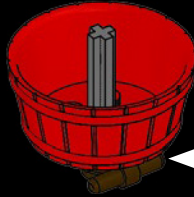

3

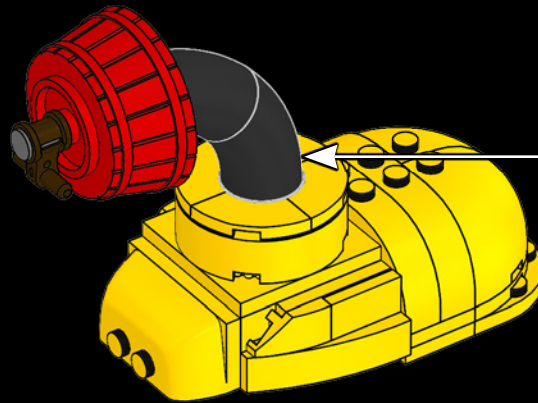

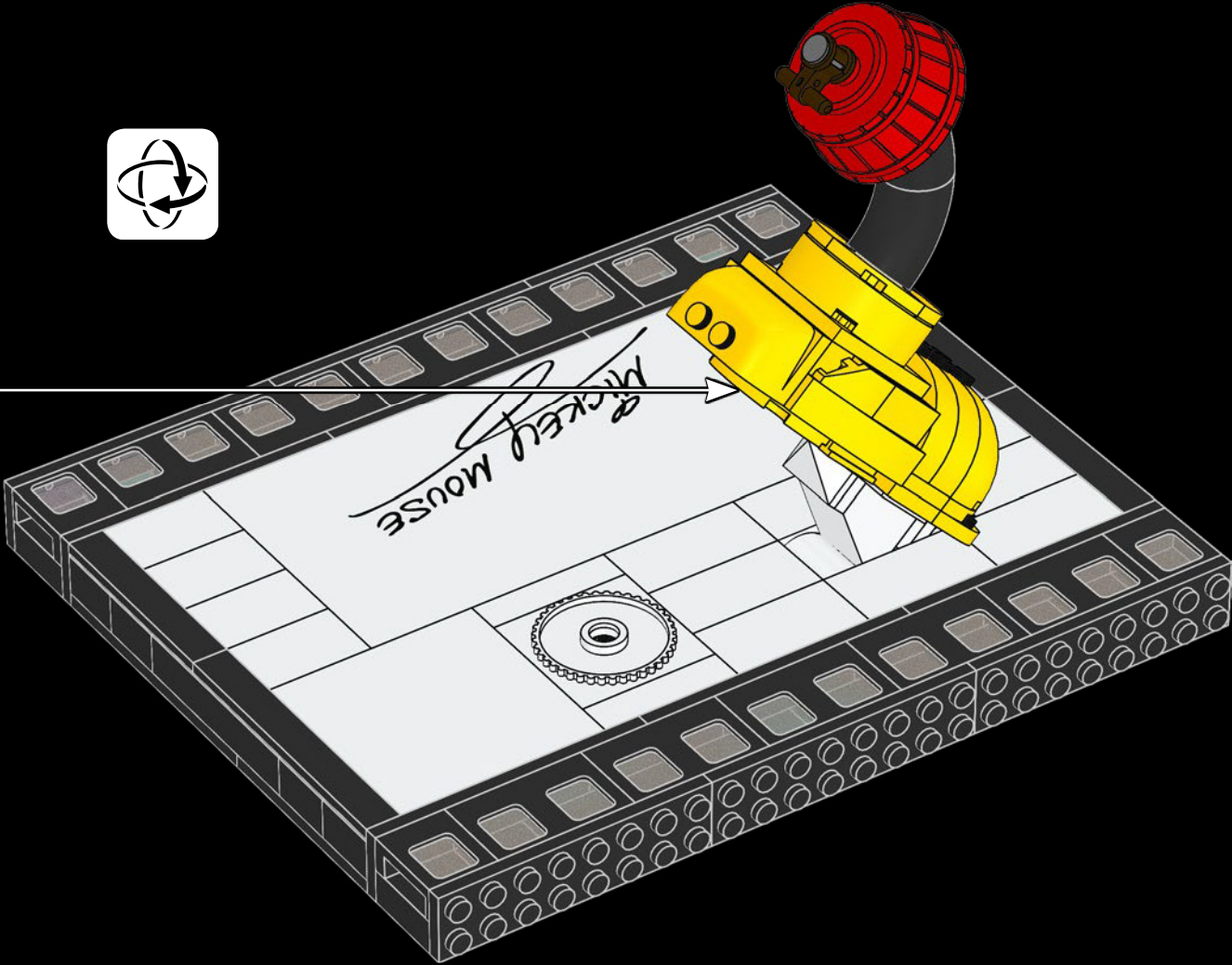

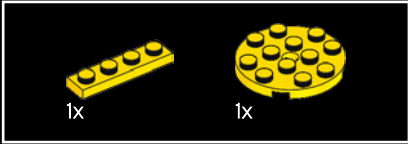
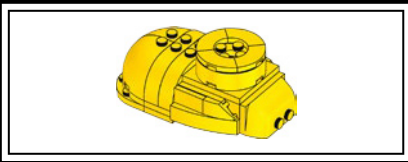

50

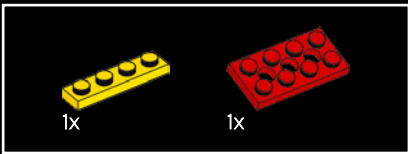
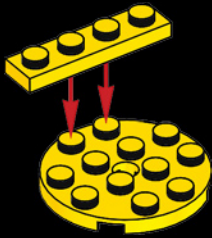

51

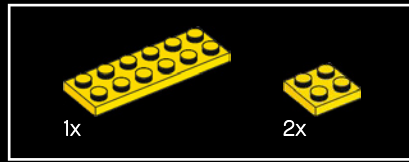
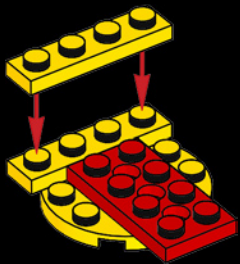

52

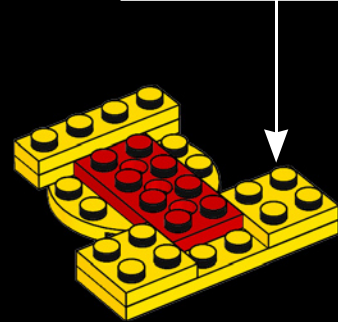
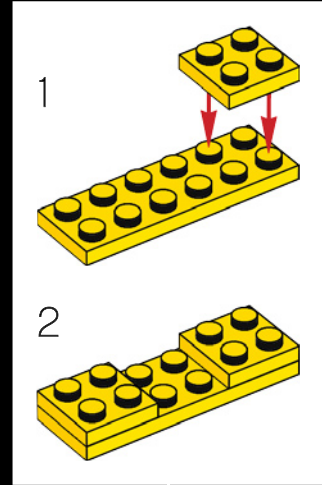

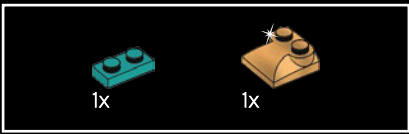

53

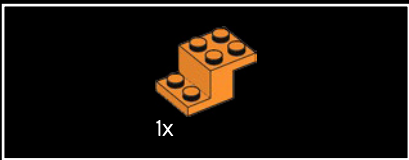
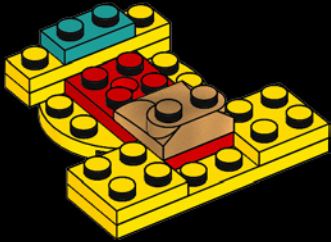

54

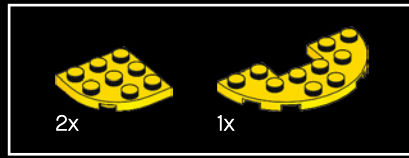
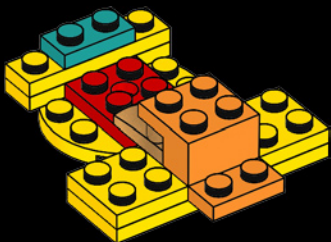

55

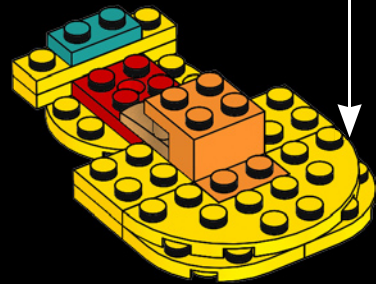
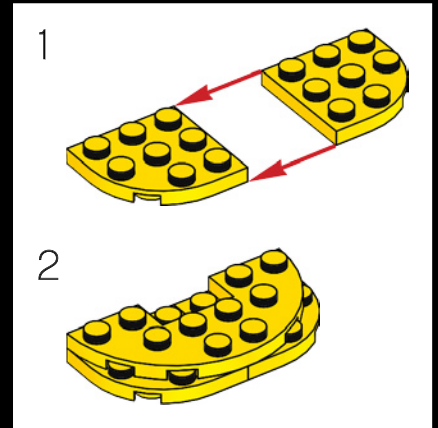

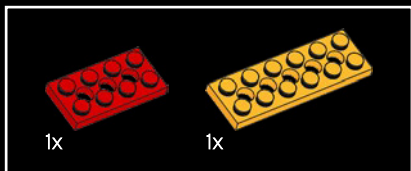

56

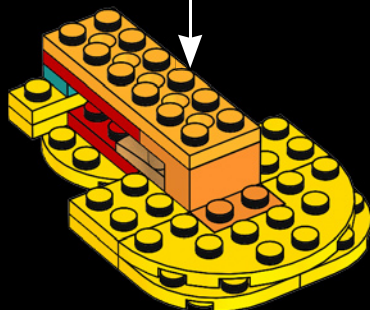
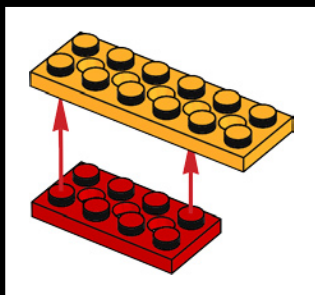

57

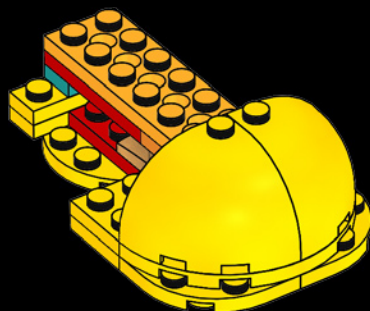

58

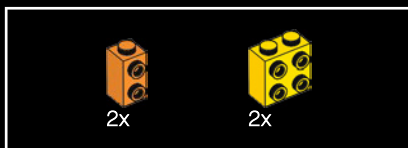
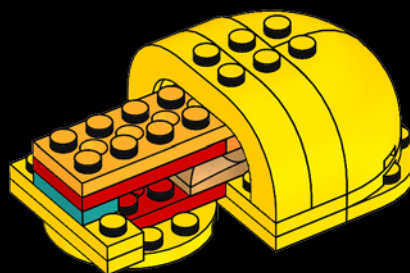

59

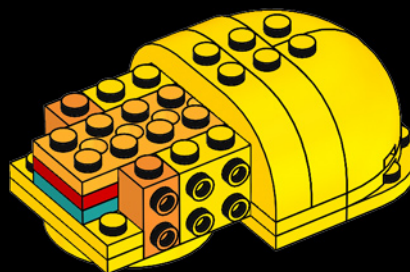

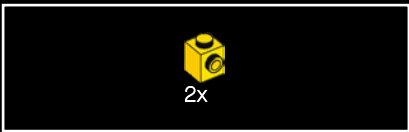

60

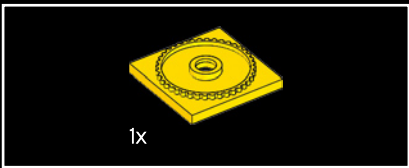
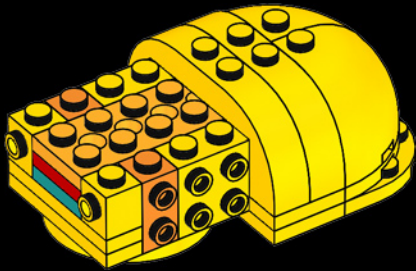

61

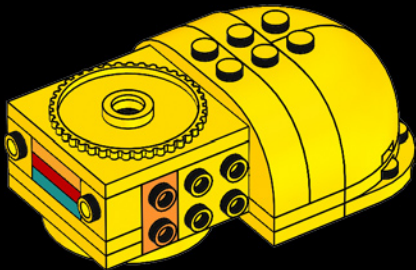

62

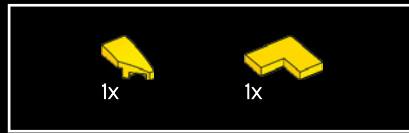
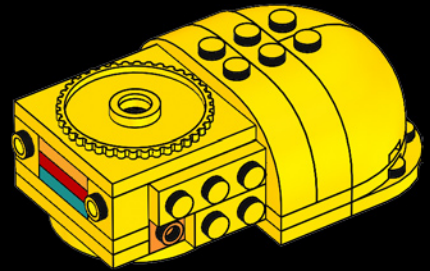

63

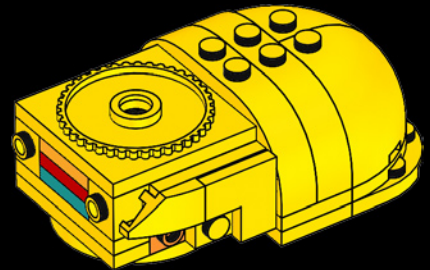

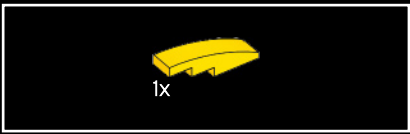

64

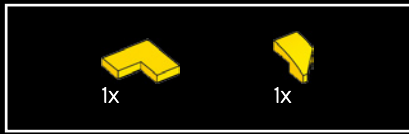

66

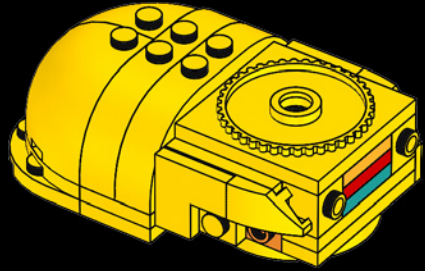
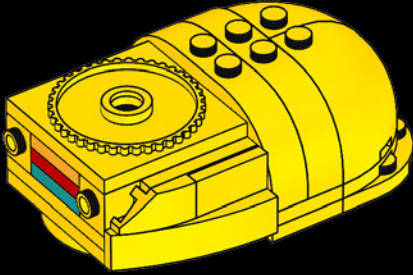

65

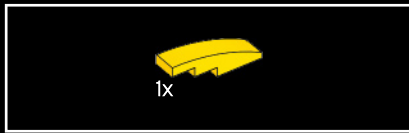

67

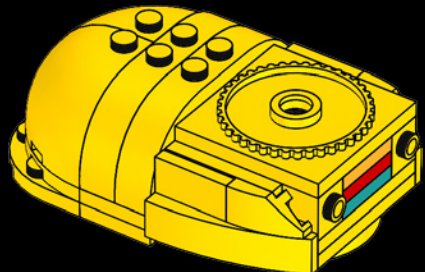
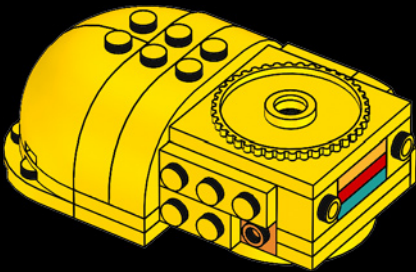

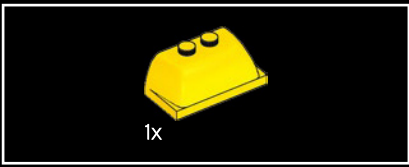

68

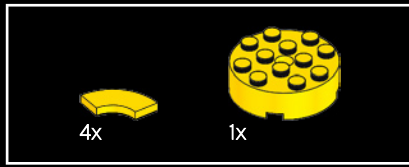
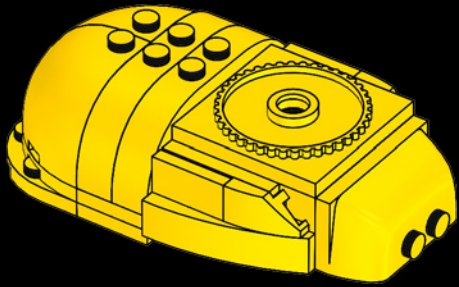

69

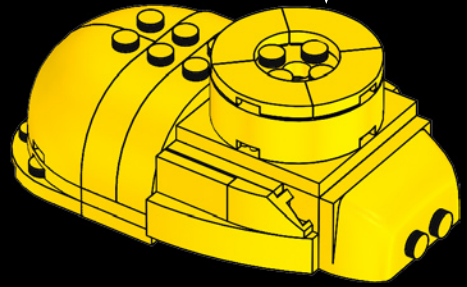
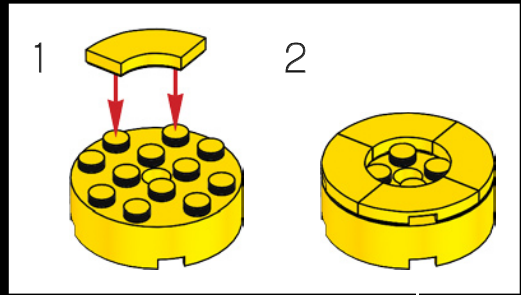

70

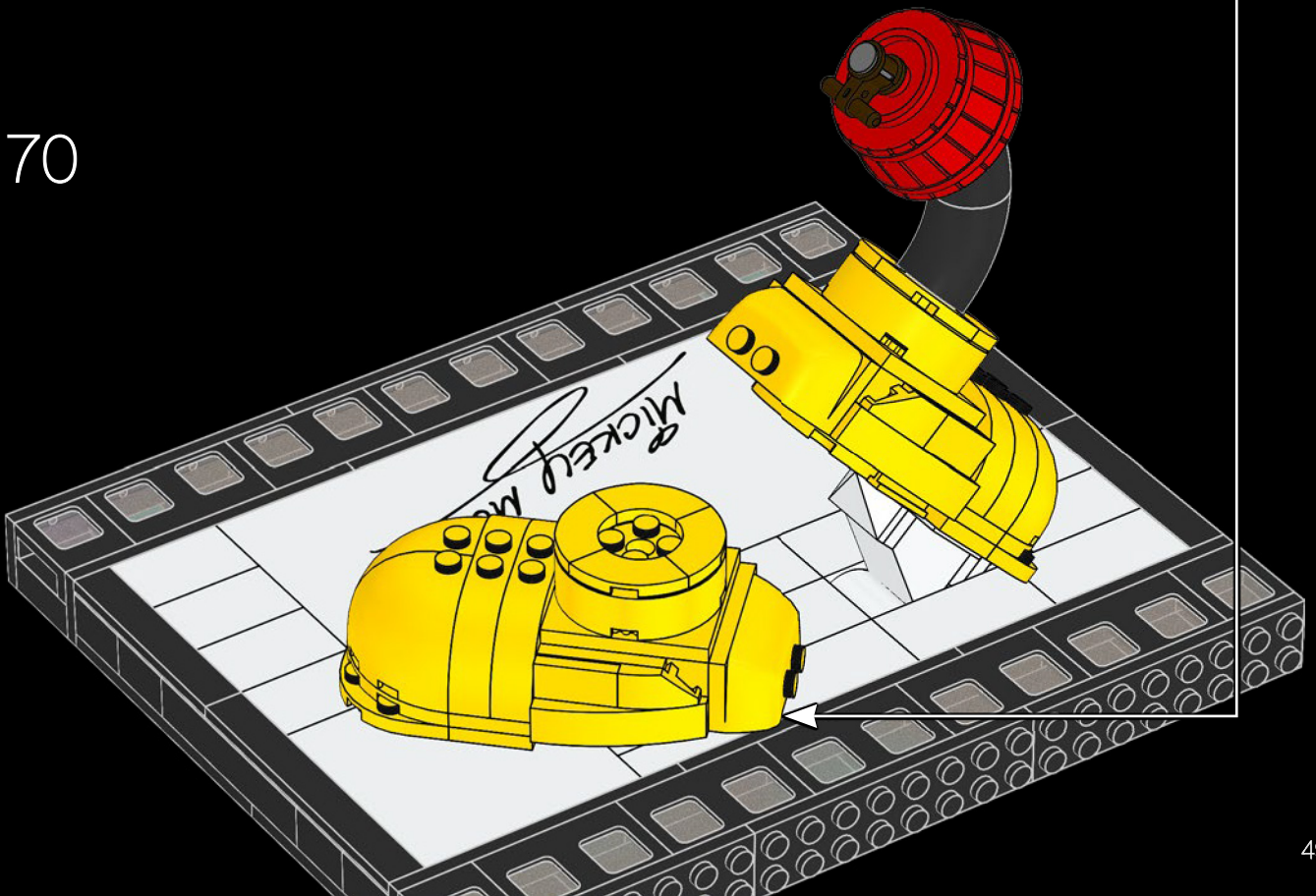

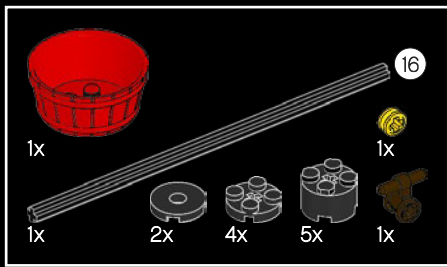

71

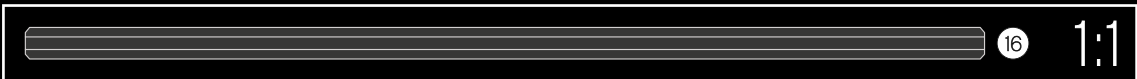
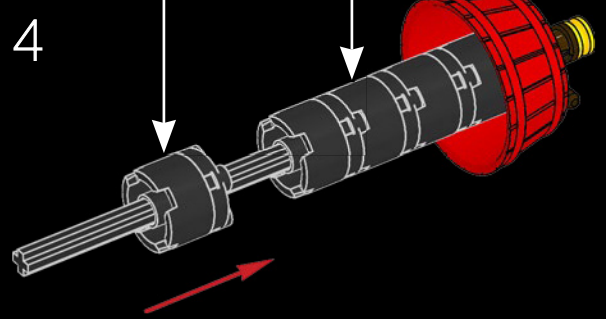
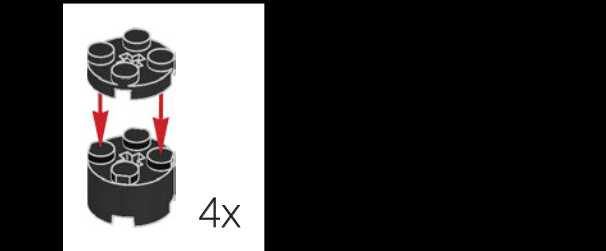
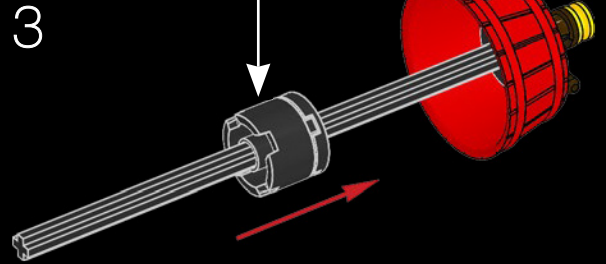
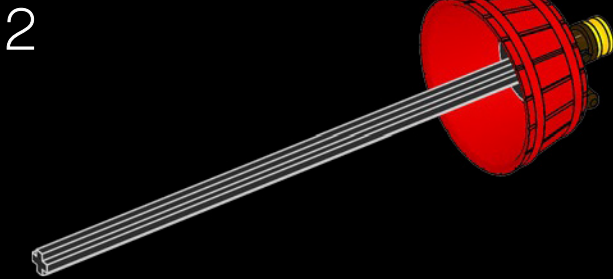
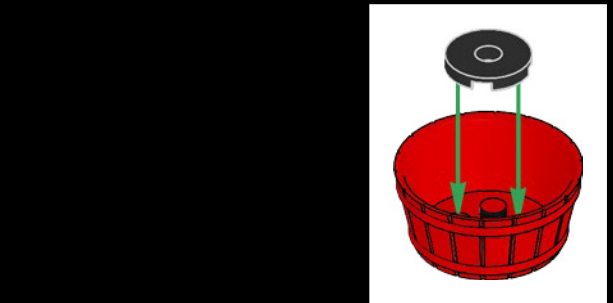
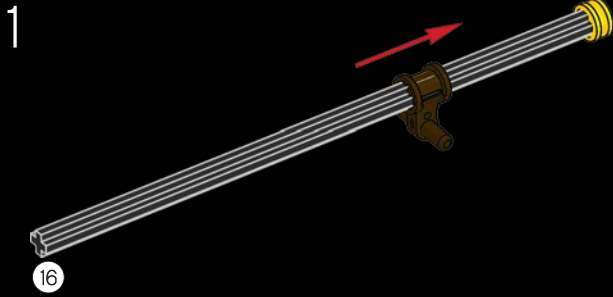

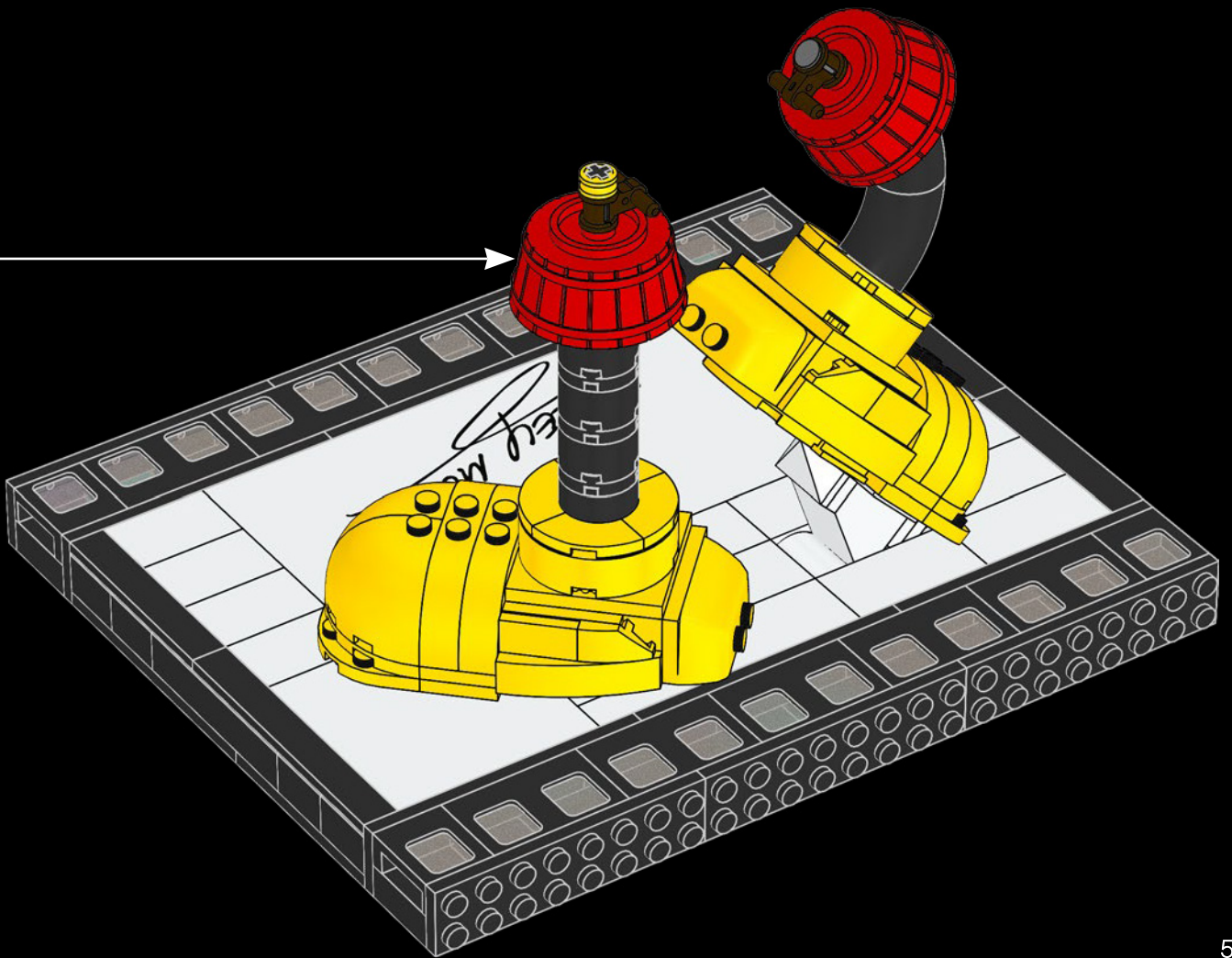

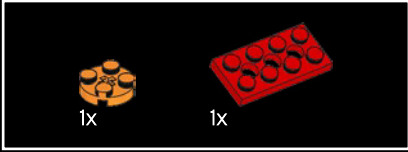
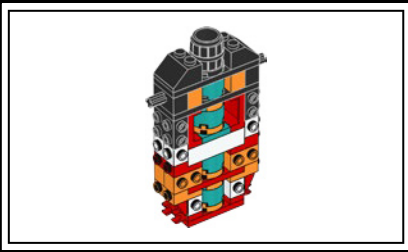

72

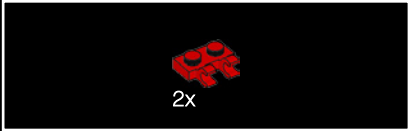

73



74

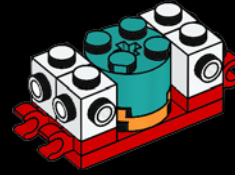

75

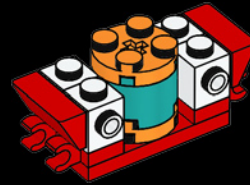

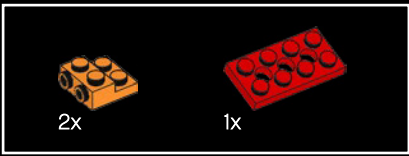

76

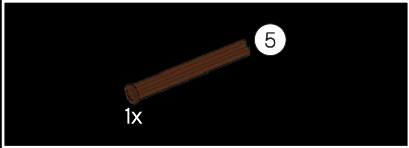
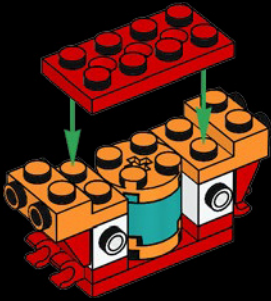

77

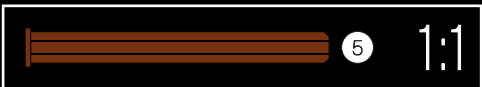
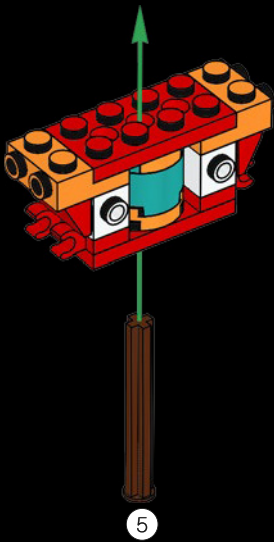

78

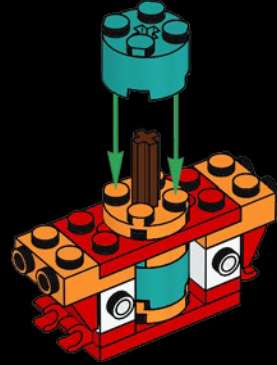

79

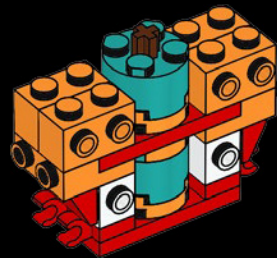

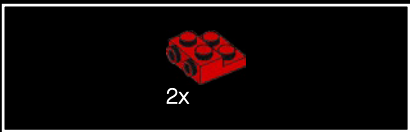

80

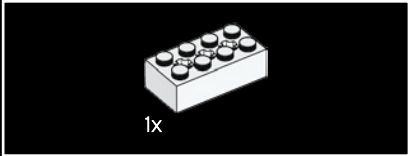
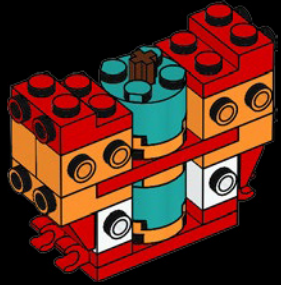

81

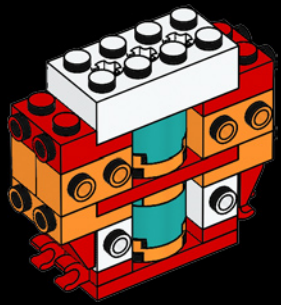

82

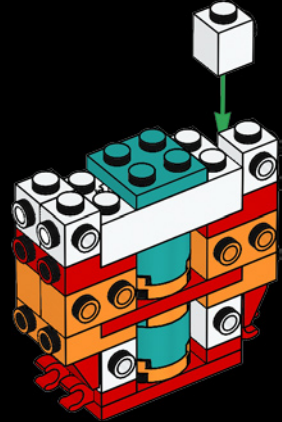

83

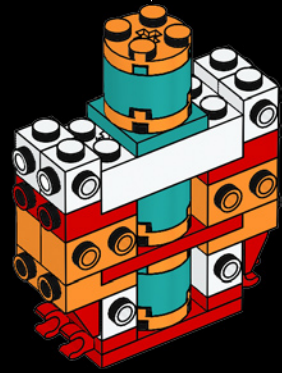
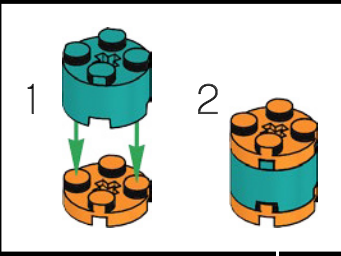

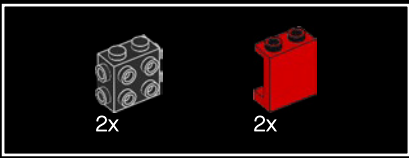

84

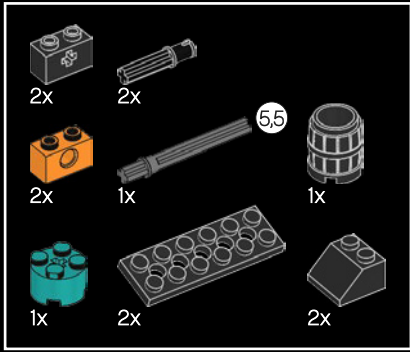
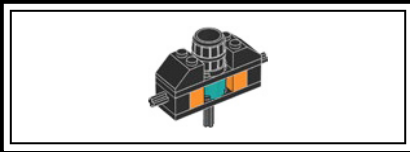
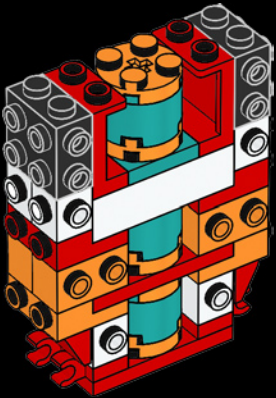

85

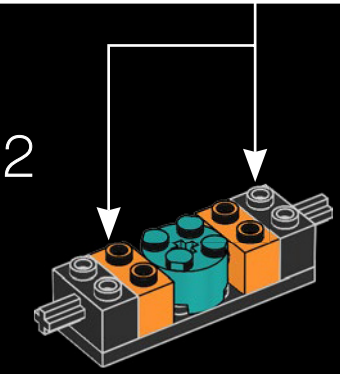
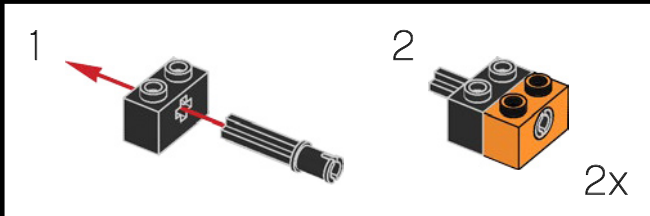
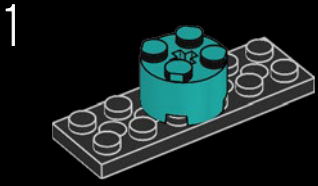

3

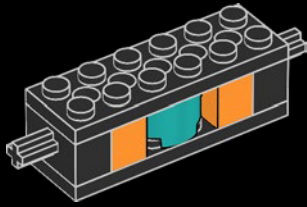

4

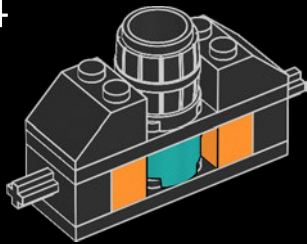

5

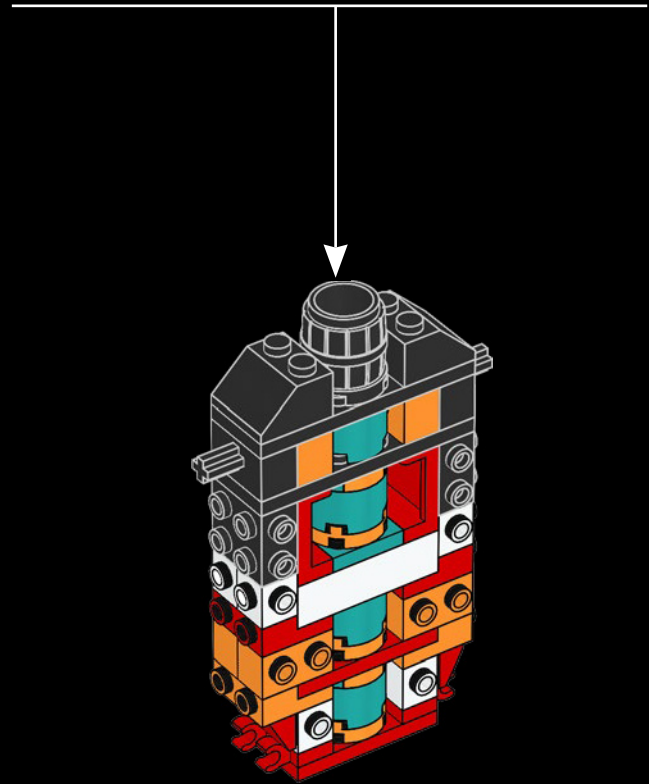
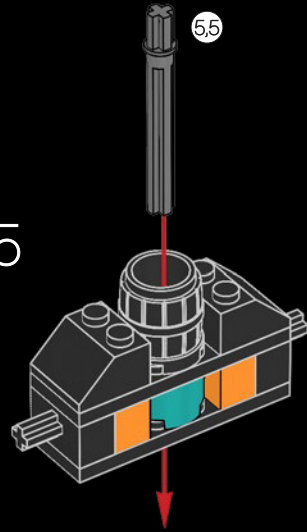

86

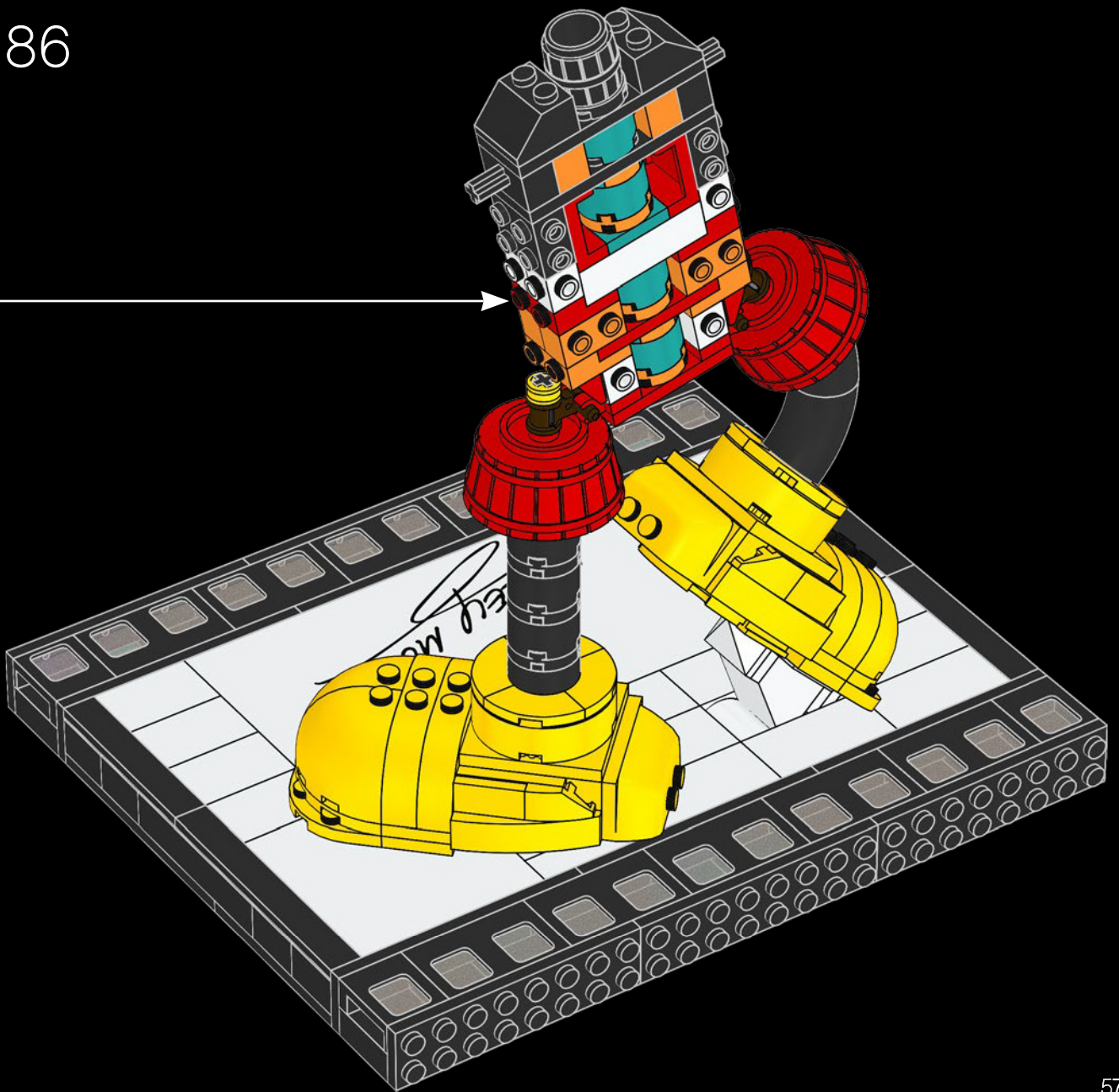

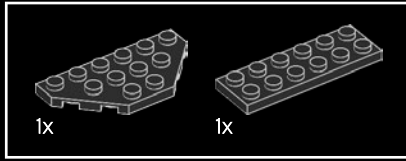
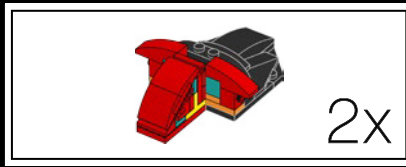
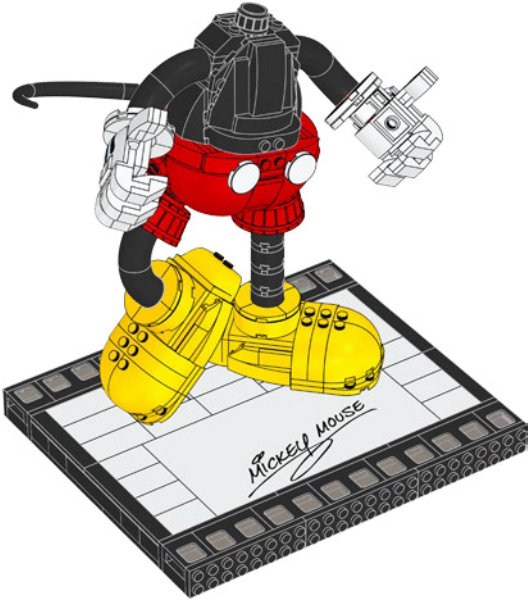
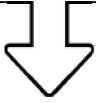

87

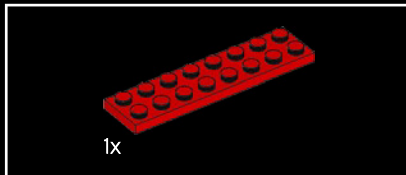
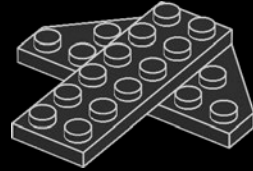

88

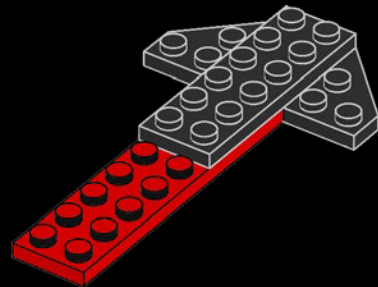

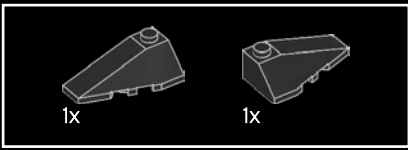

89

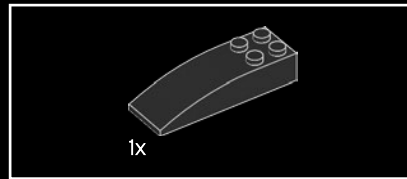
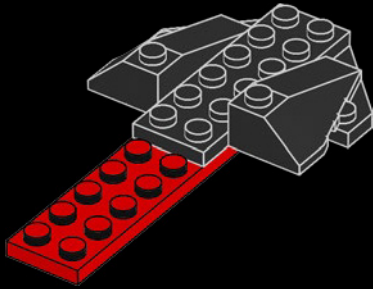

91

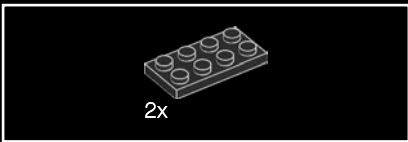
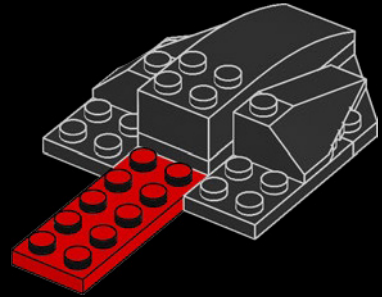

90

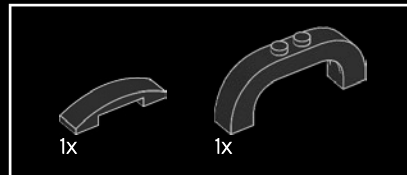
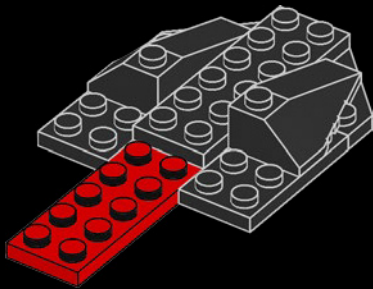

92

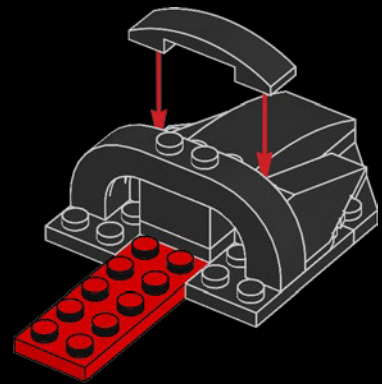

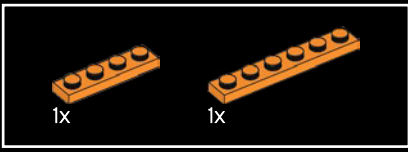

93

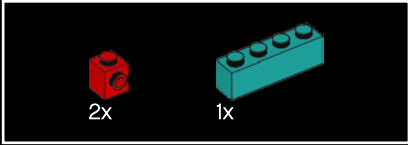
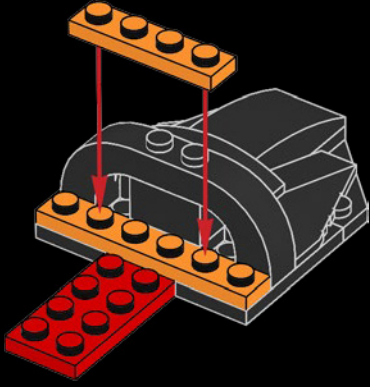

94

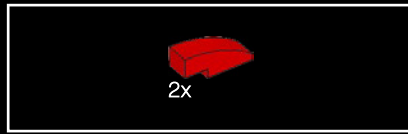
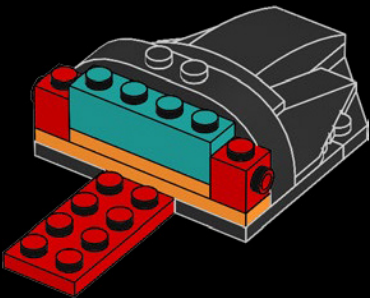

95

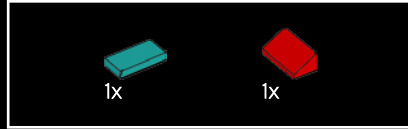
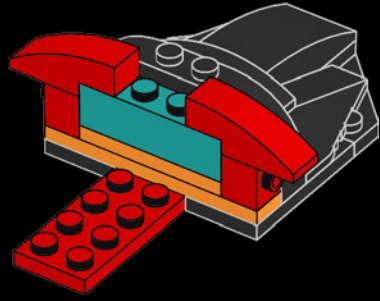

96

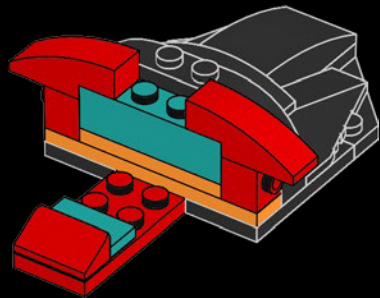

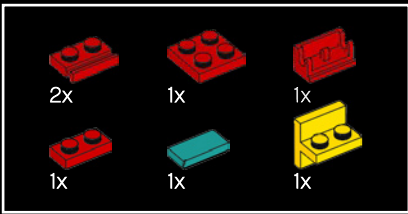

97

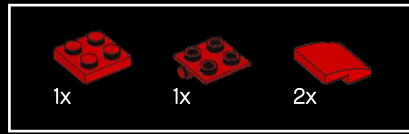
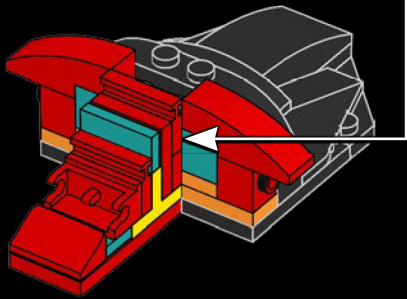
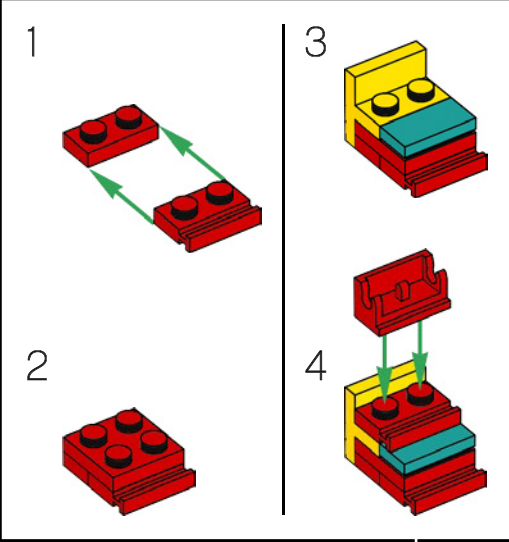

98

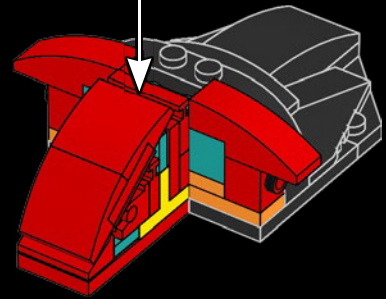
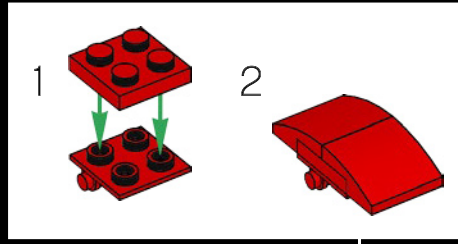

2x

99

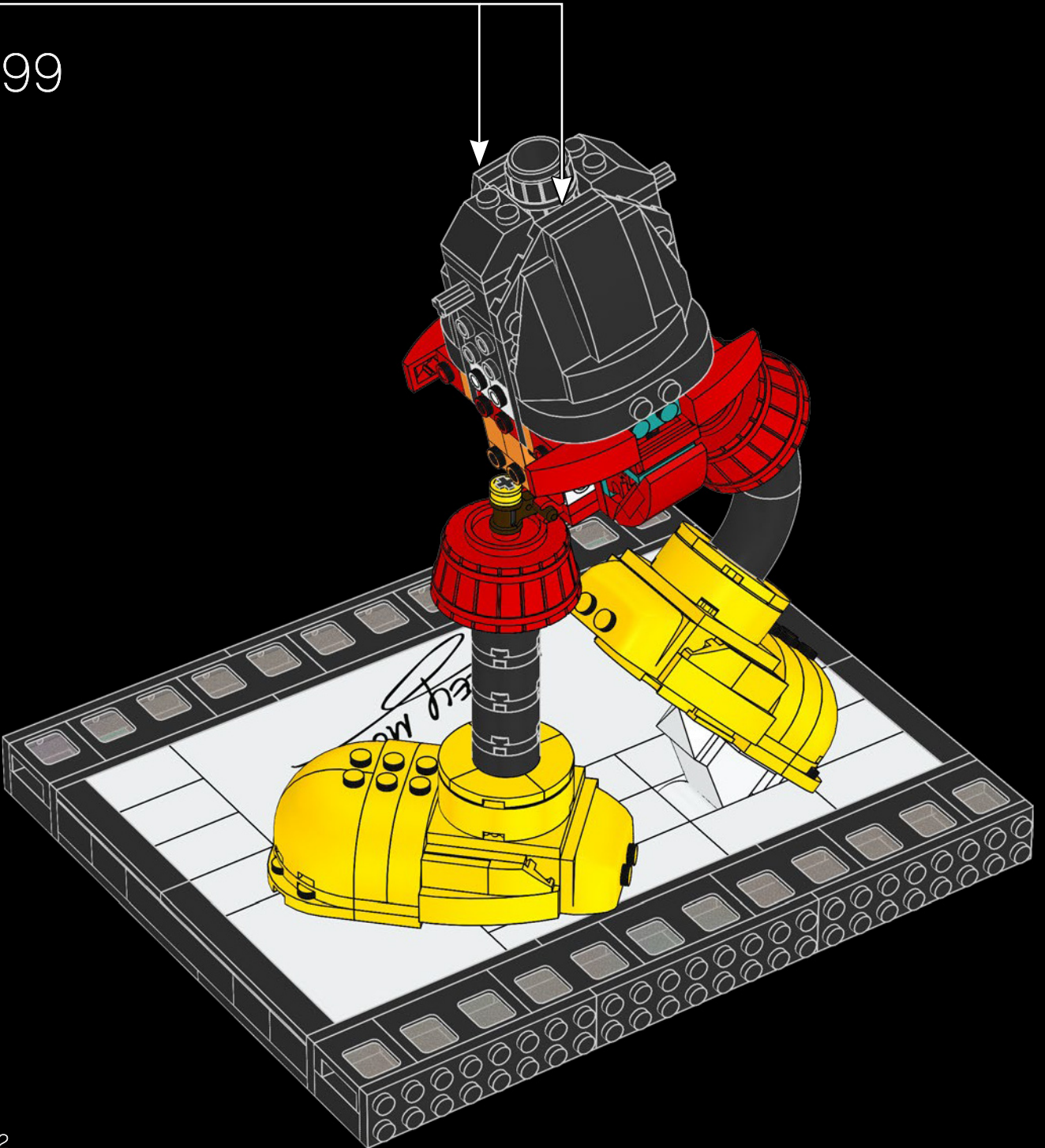

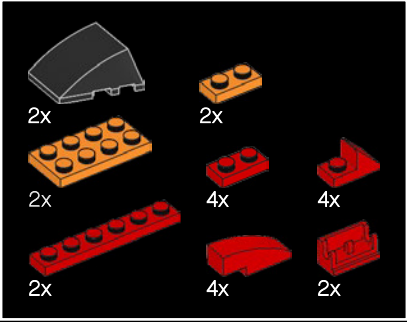
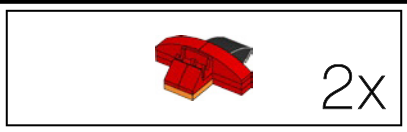

100

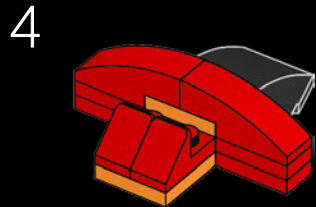
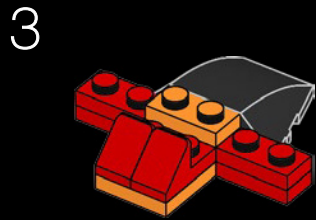
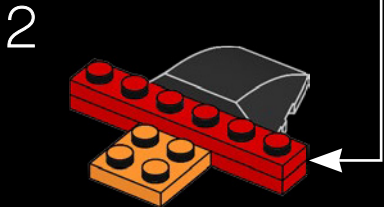
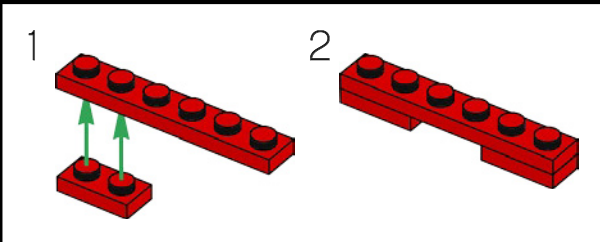
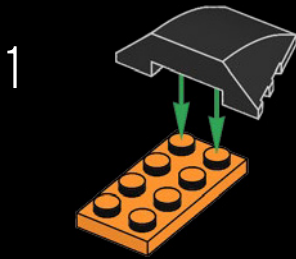

5

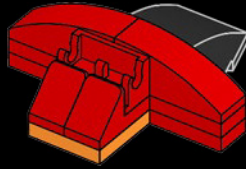

2x

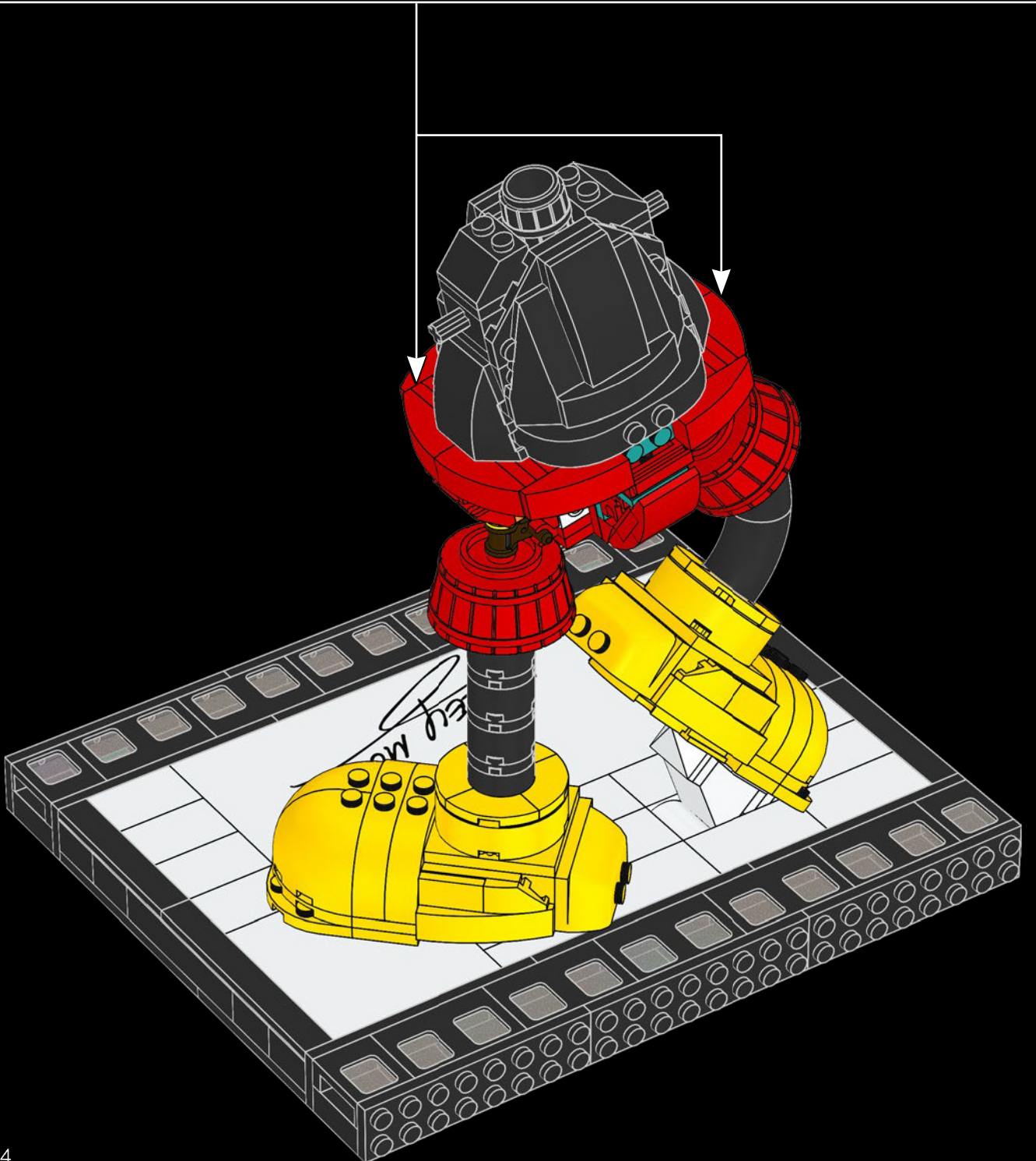

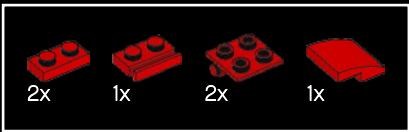

101

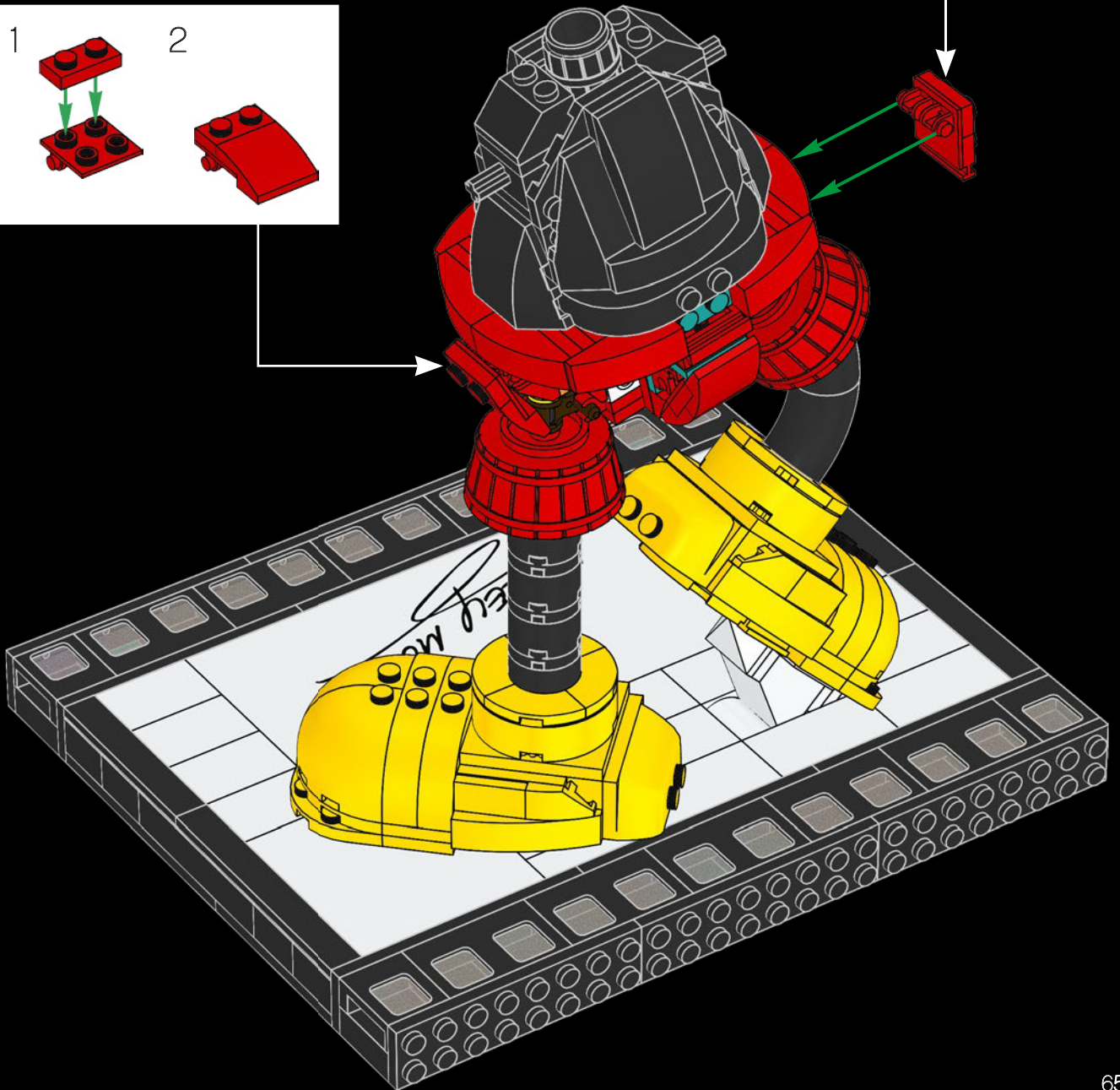
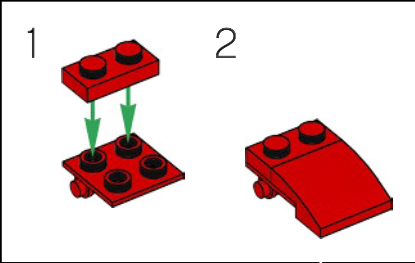
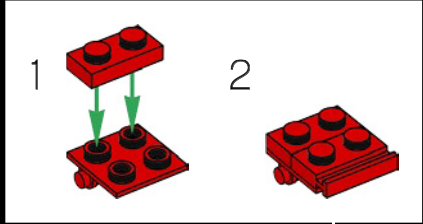

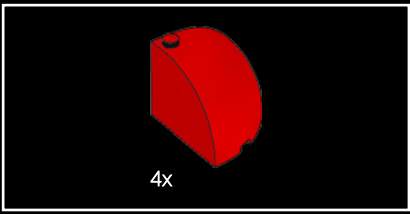

102

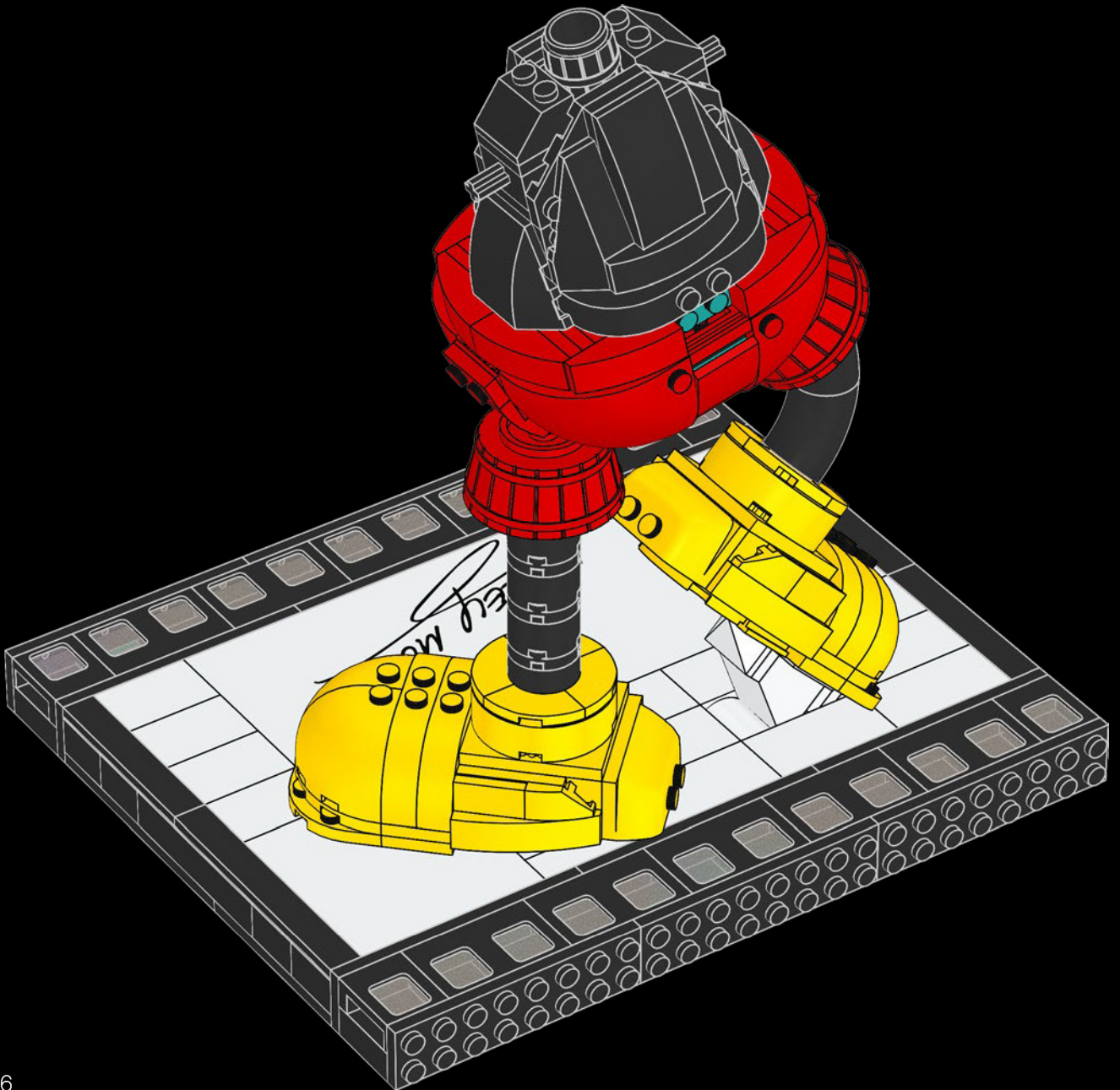



103

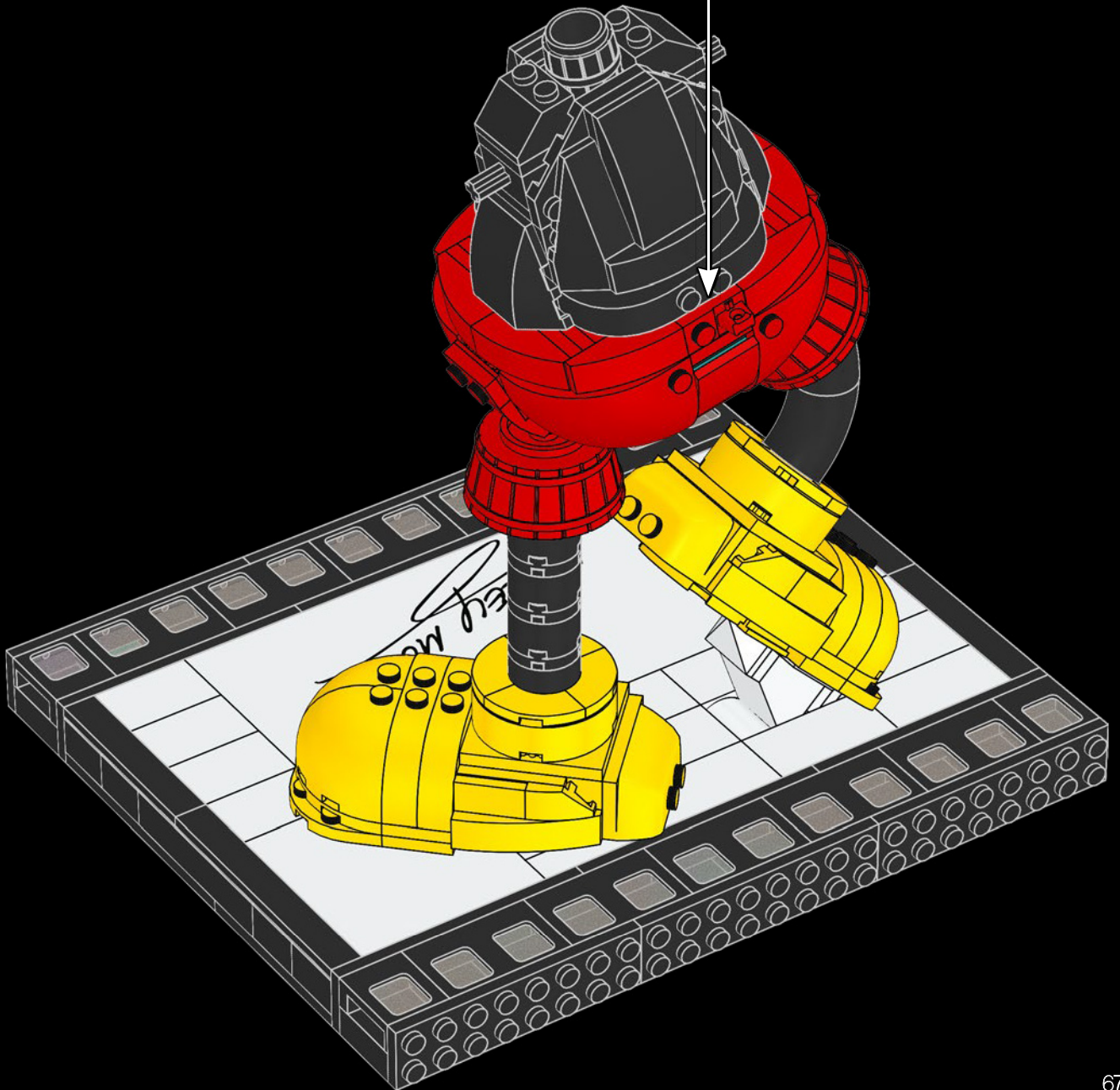
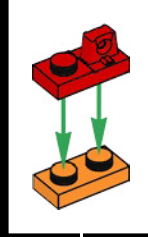

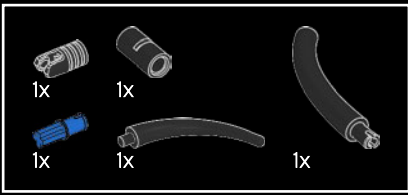

104

1

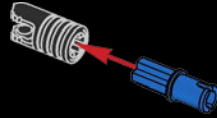

2

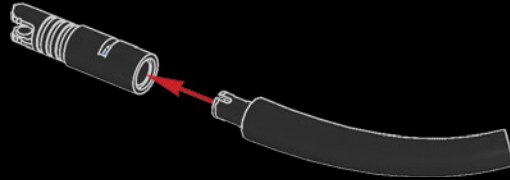

3



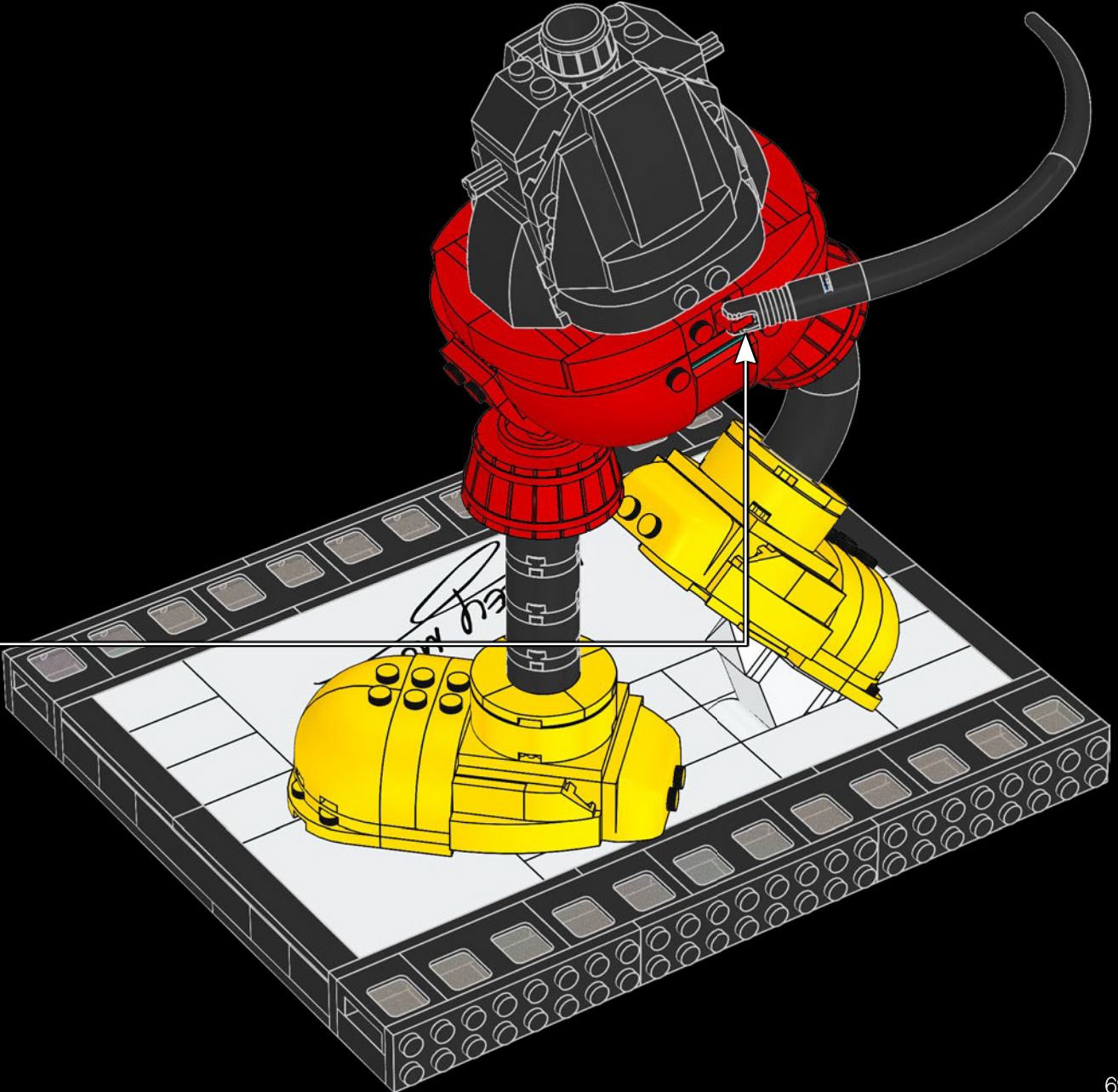

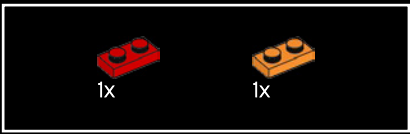

105

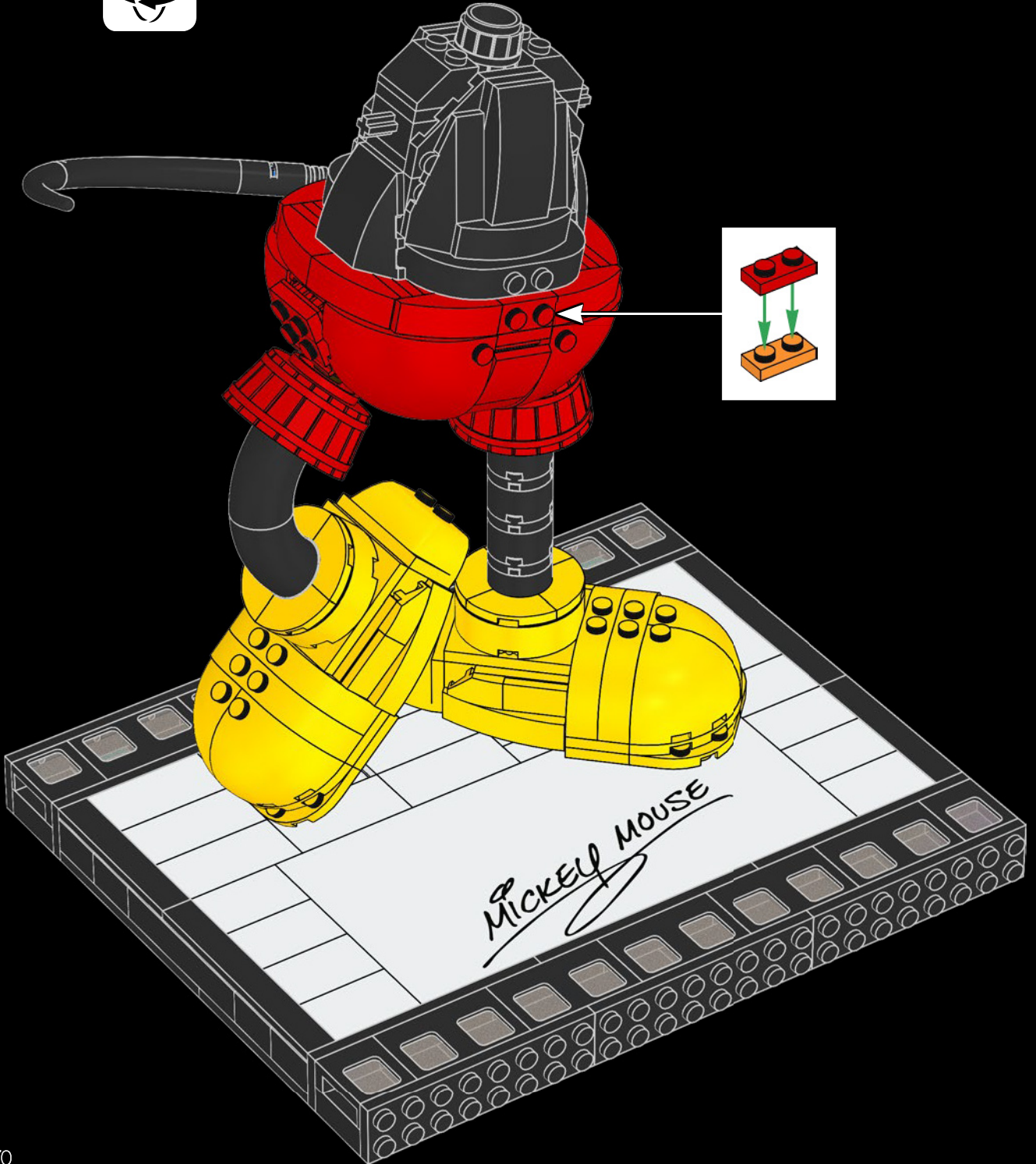



106

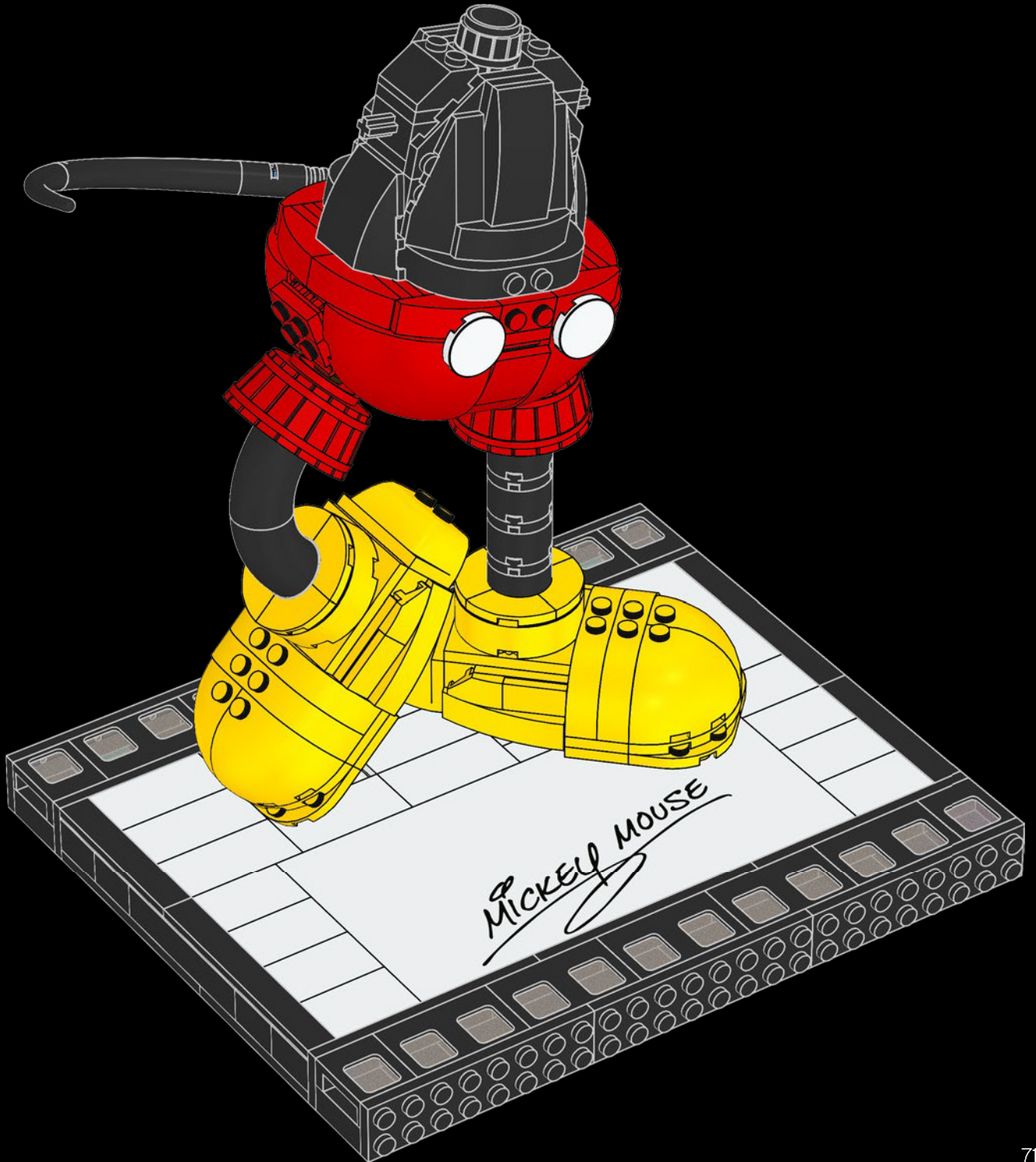

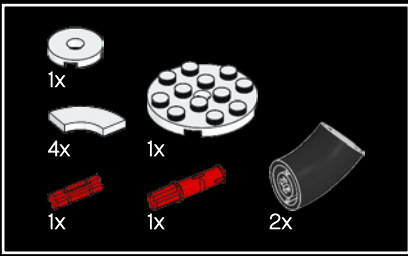

107

1

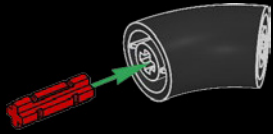

3



2

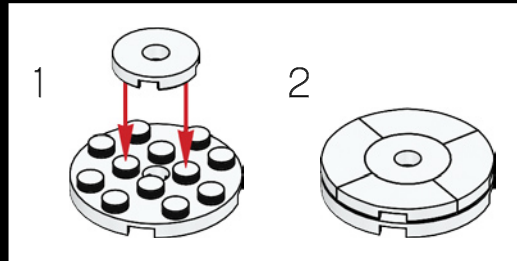

4

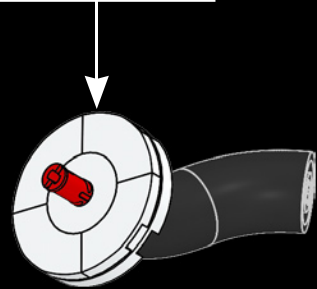

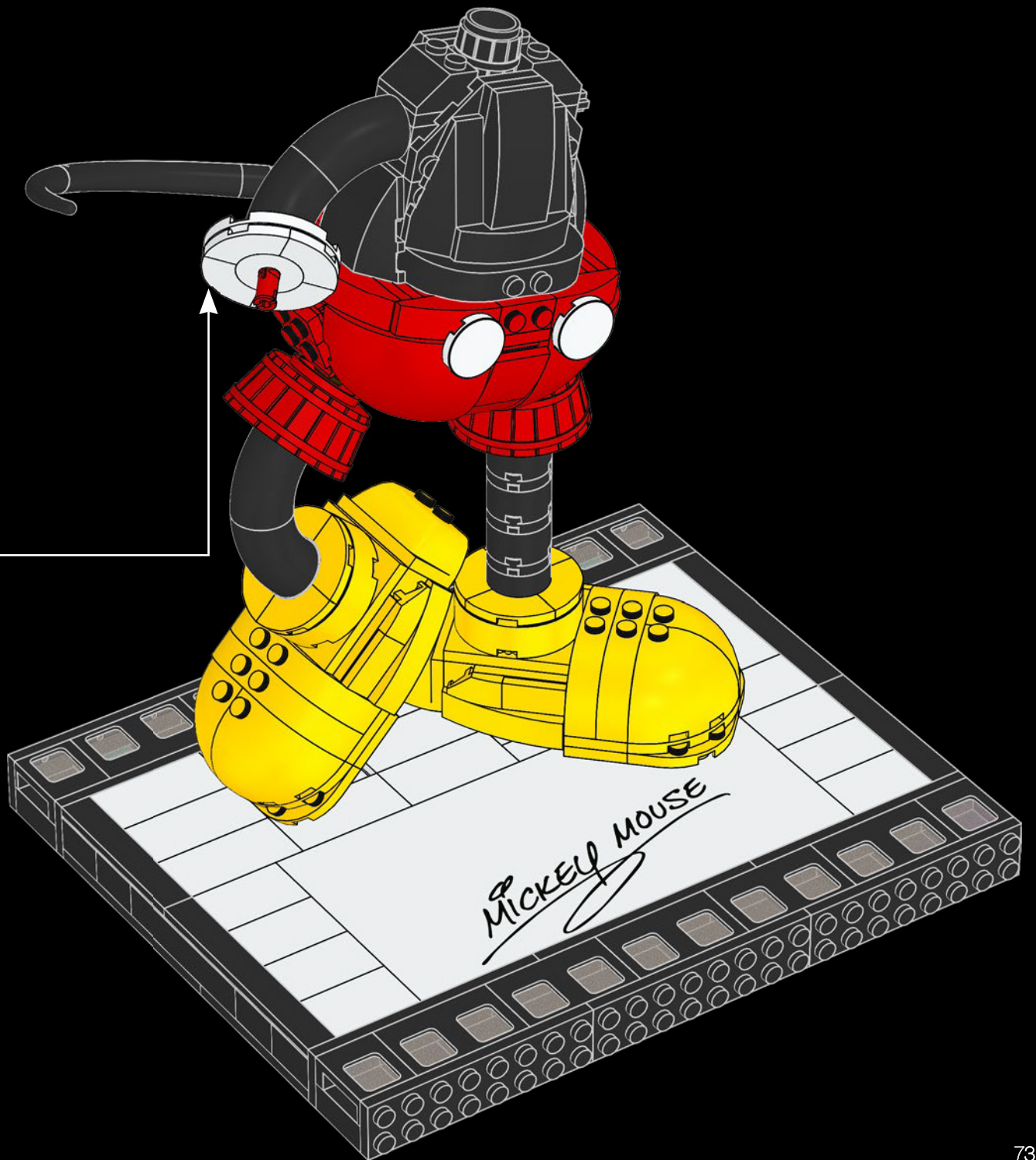

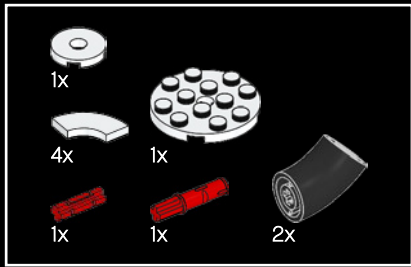

108

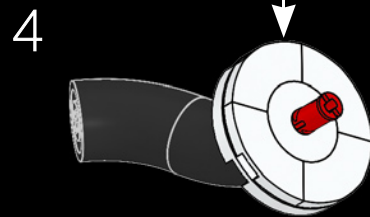
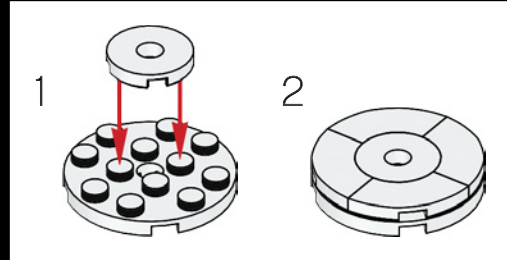
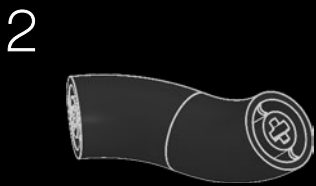
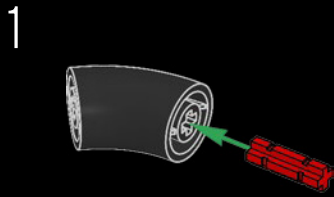

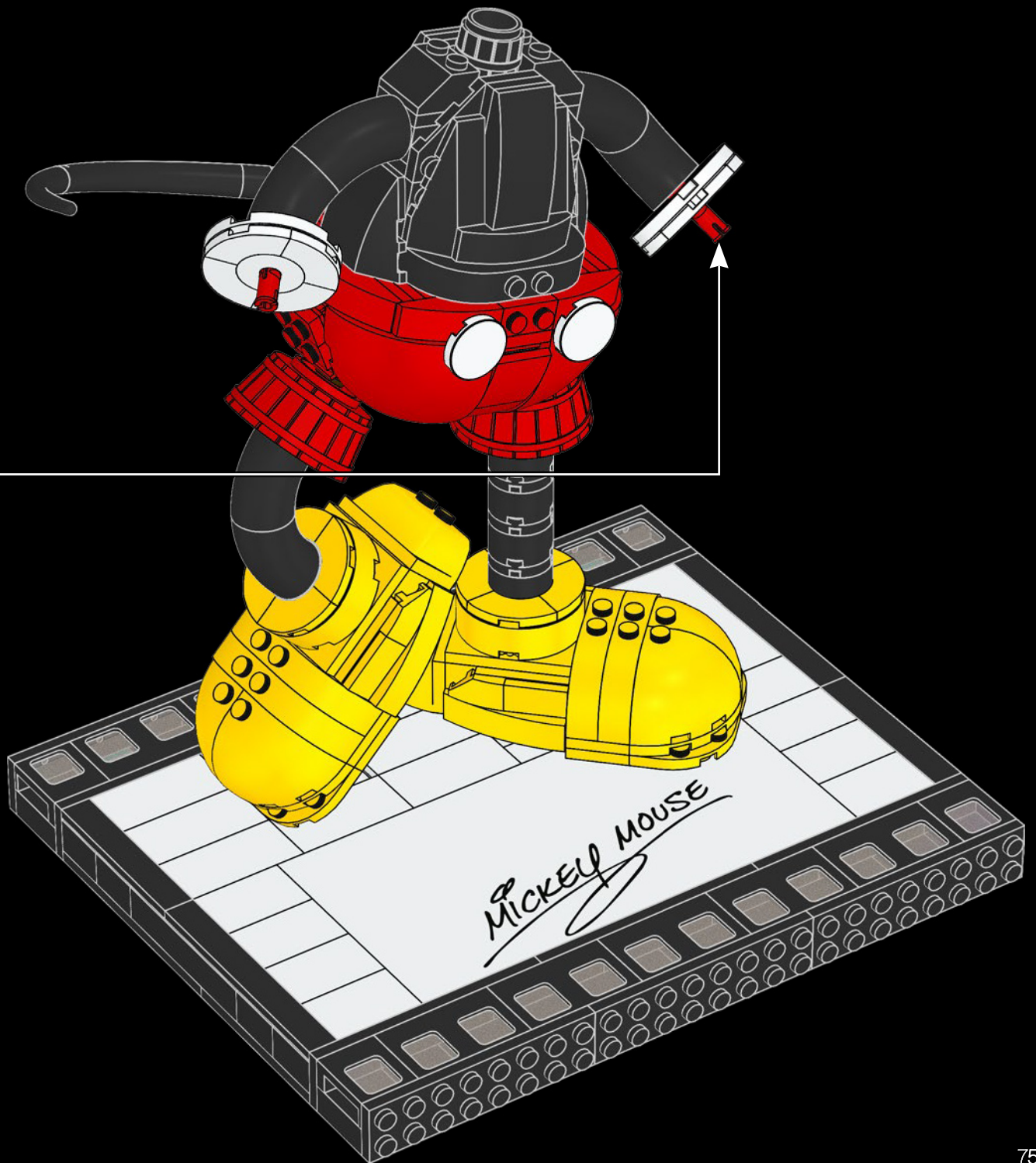

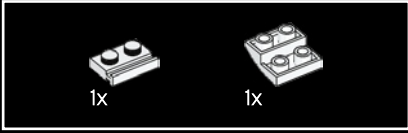
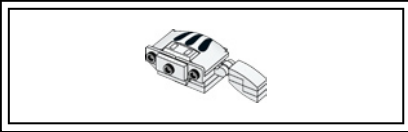

109

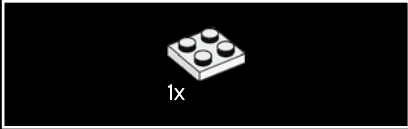
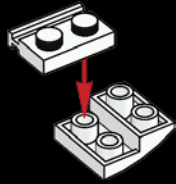

110

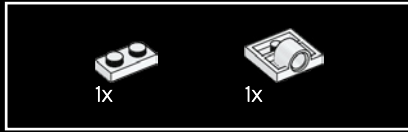
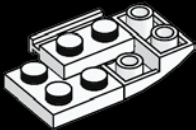

111

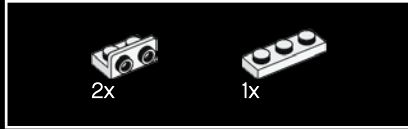
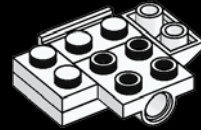

112





113

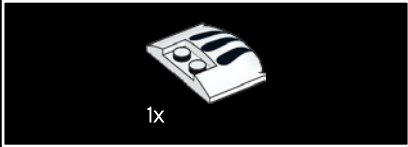

114

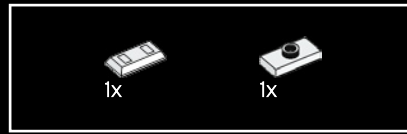

115

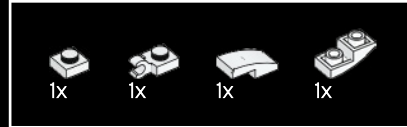

116

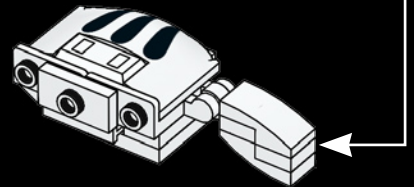
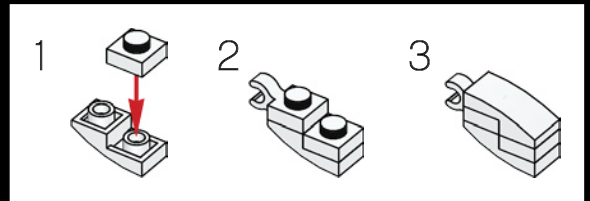

117

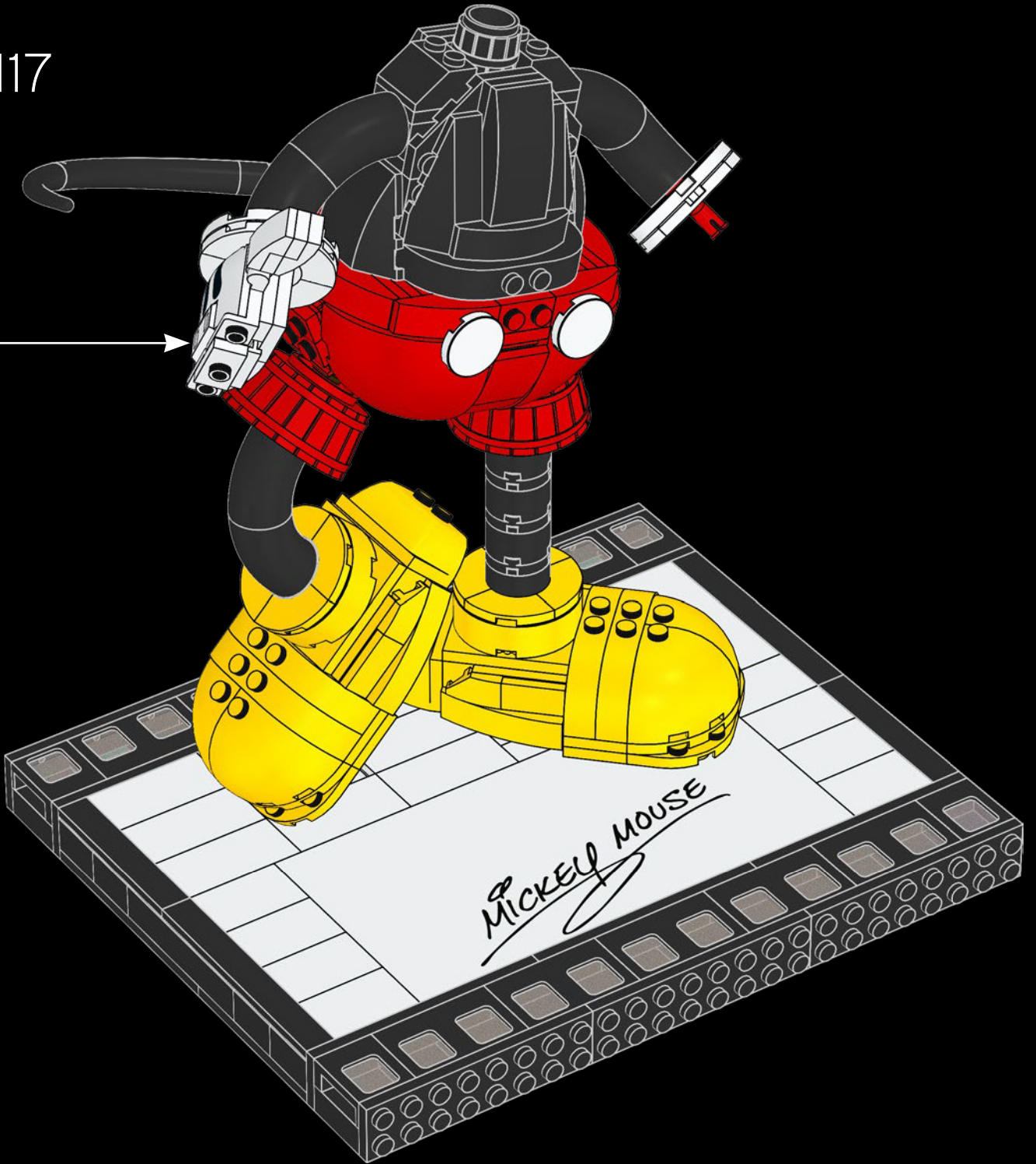

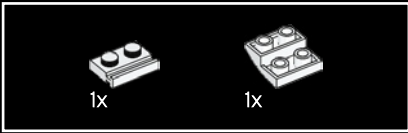
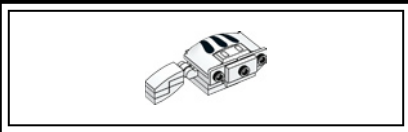

118

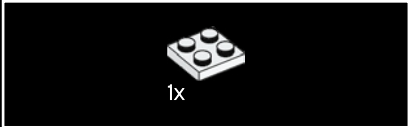
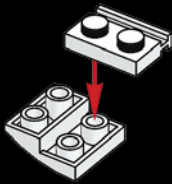

119

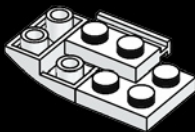

120



121





122

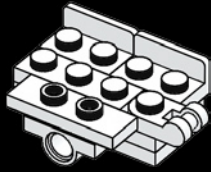

123

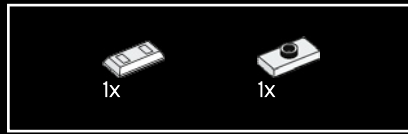

124

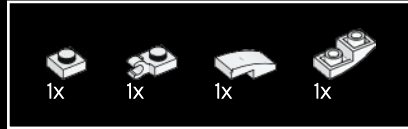

125

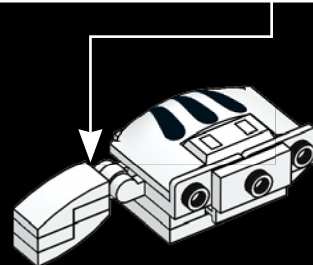
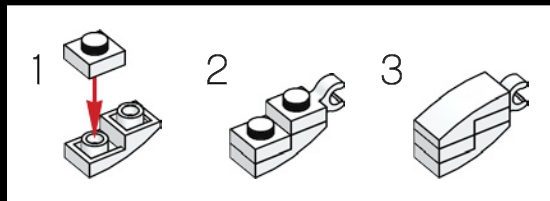

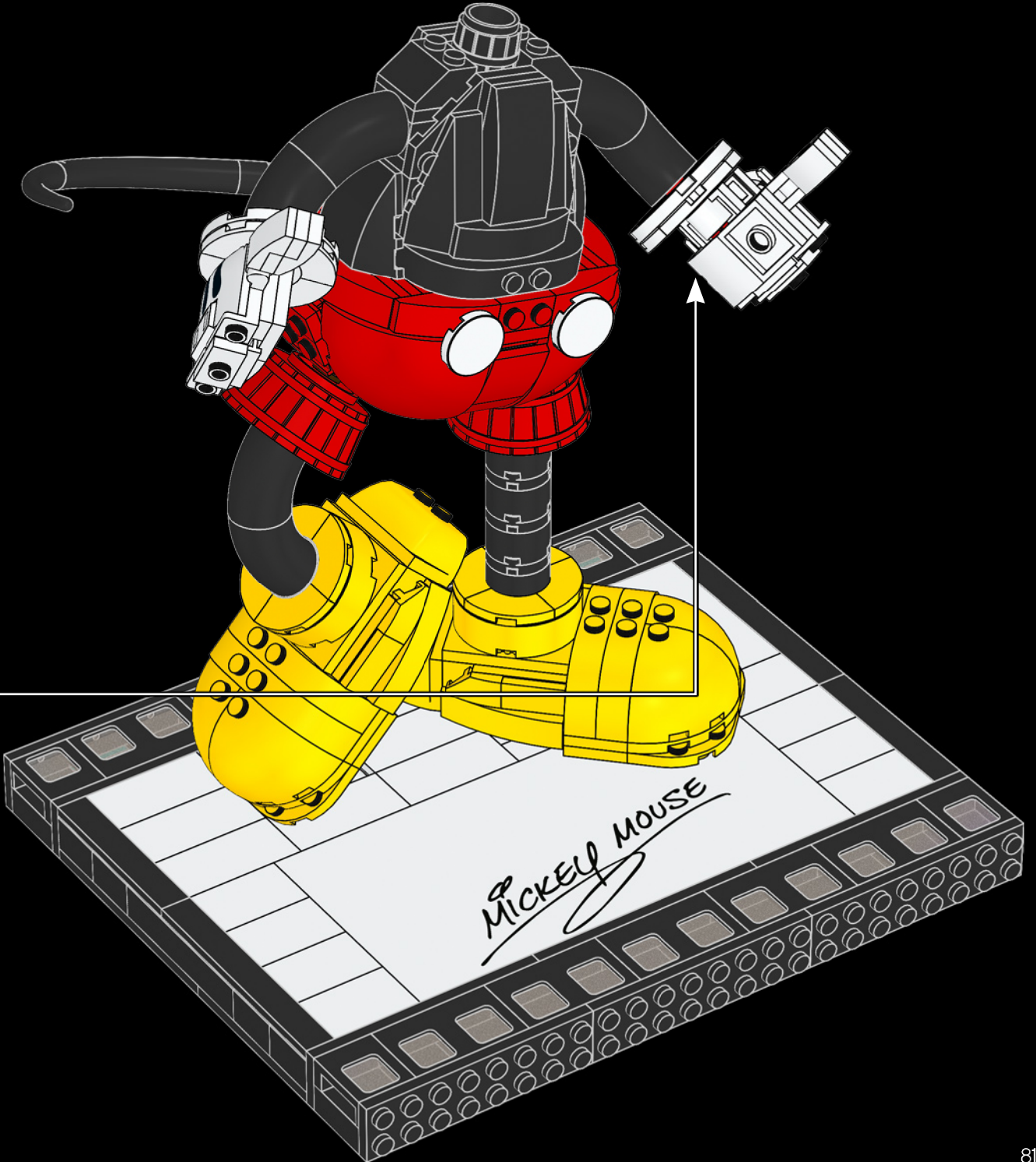



127

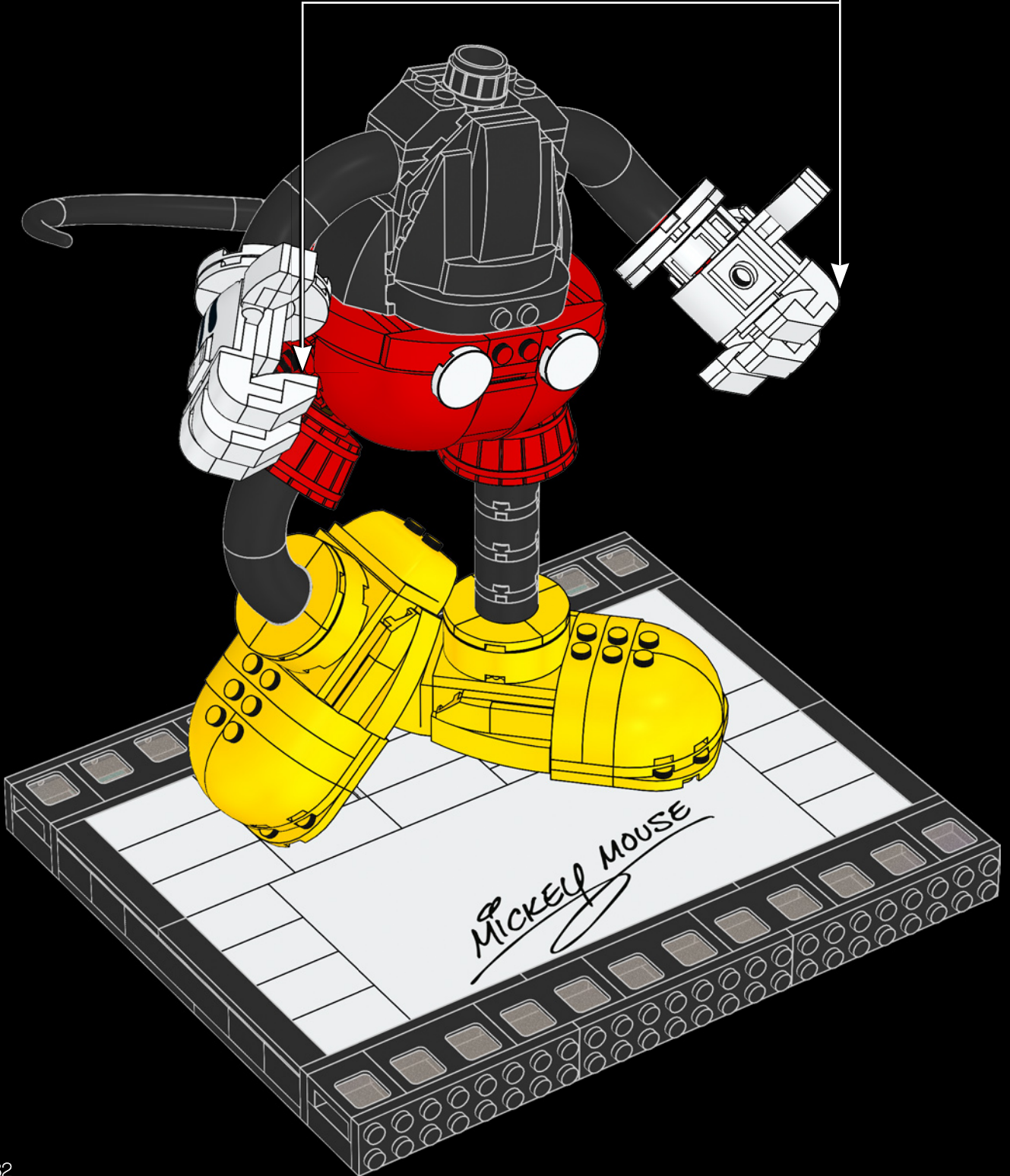
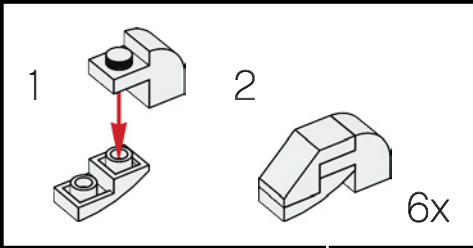

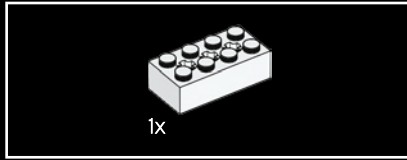
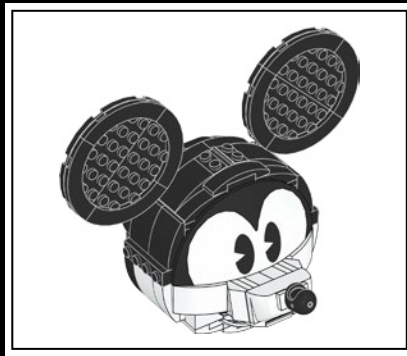
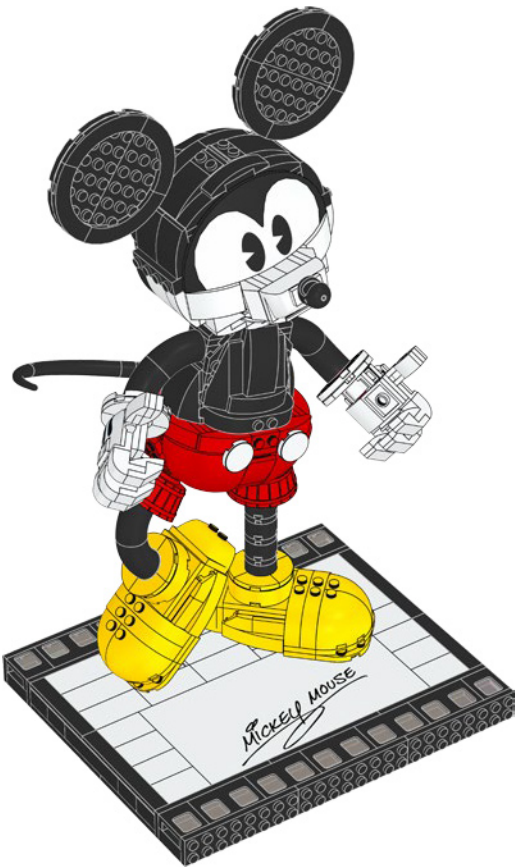

128

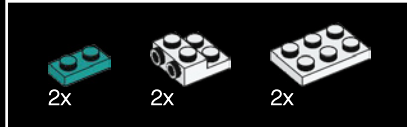
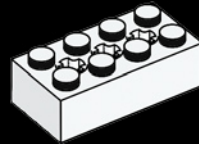

129

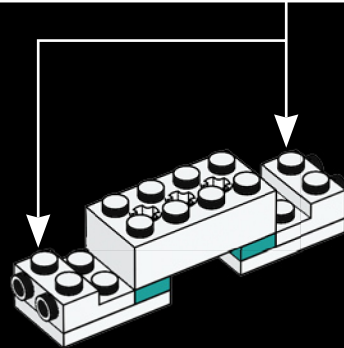
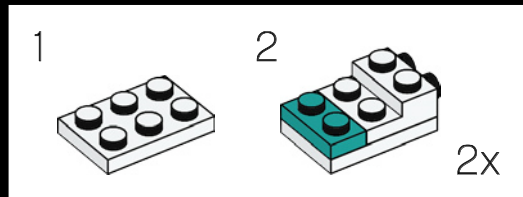



130

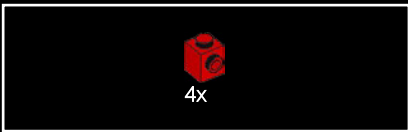
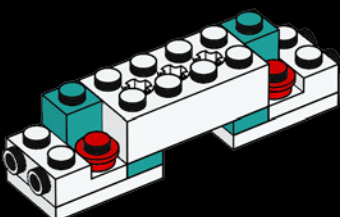

131

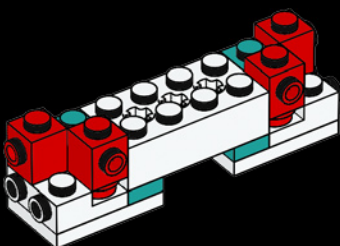

132

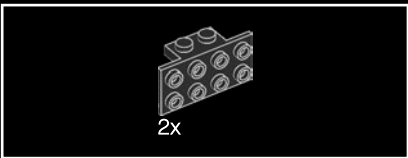
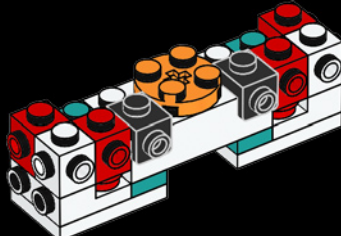

133

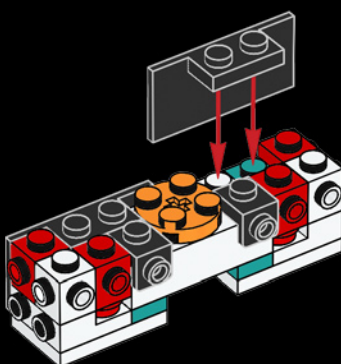

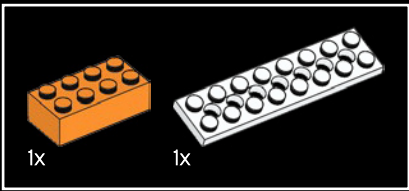

134

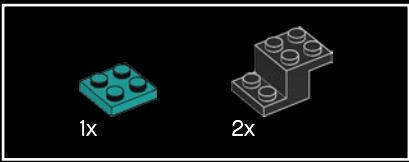
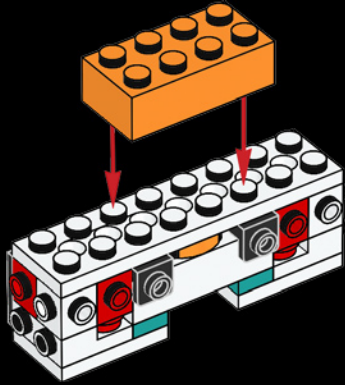

135

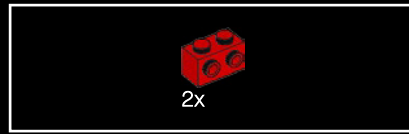
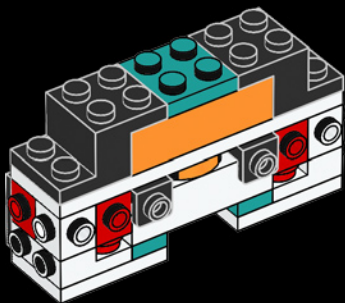

136

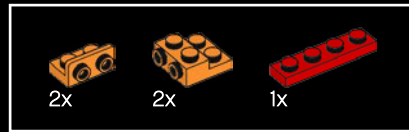
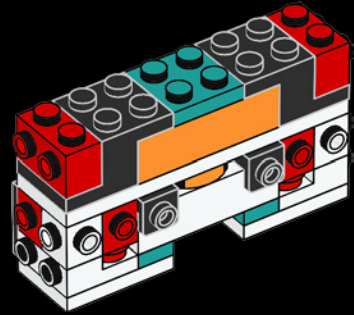

137

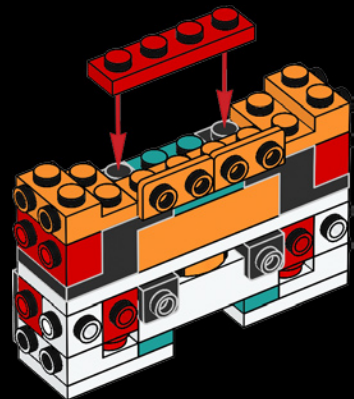

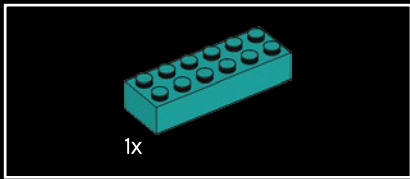

138

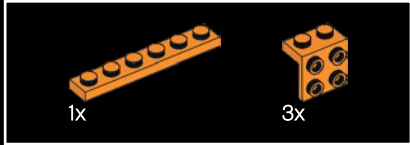
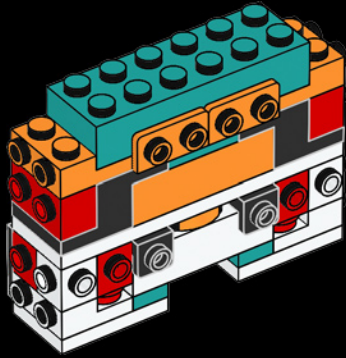

139

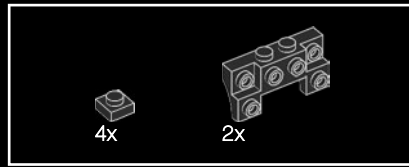
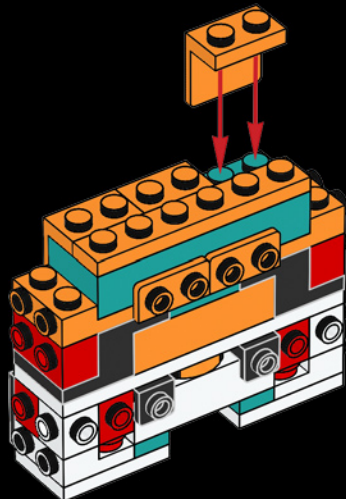

140

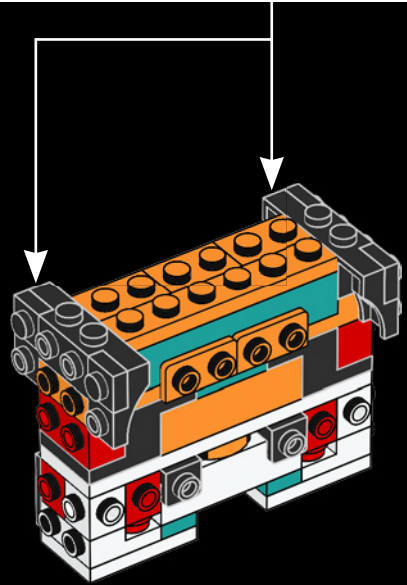
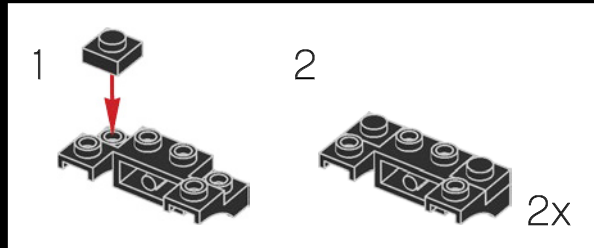

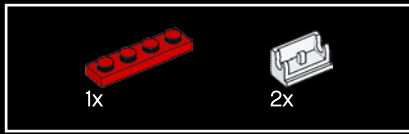
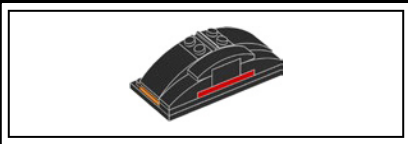

143

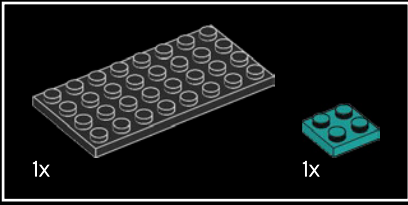

141

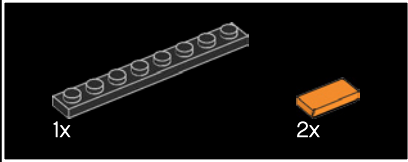
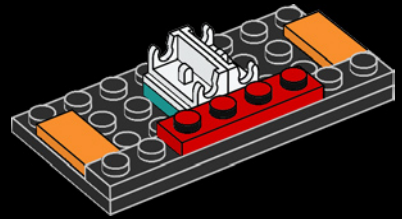
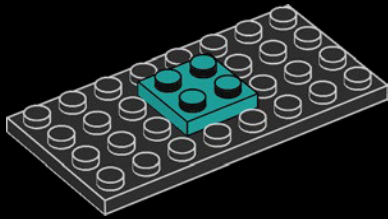

142

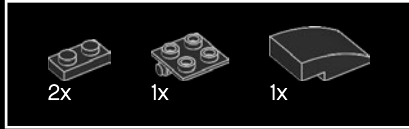
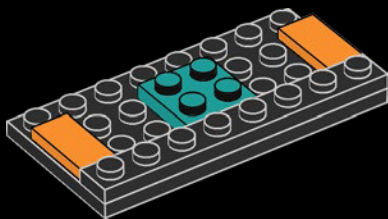

144

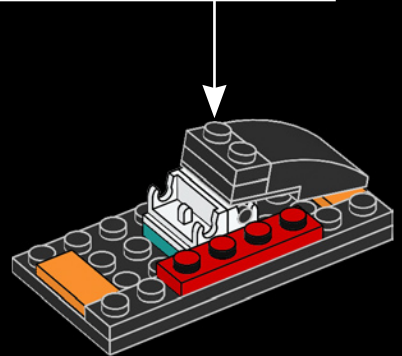
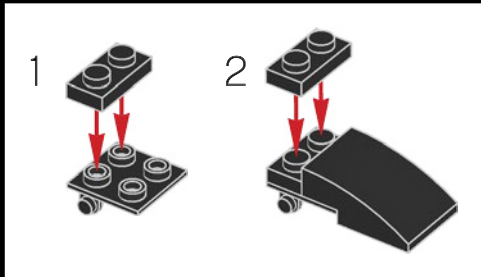

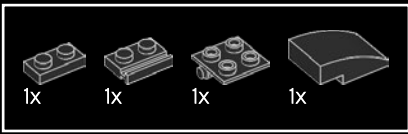

145

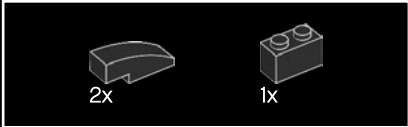
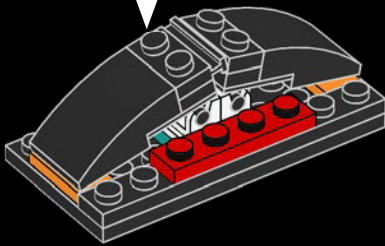
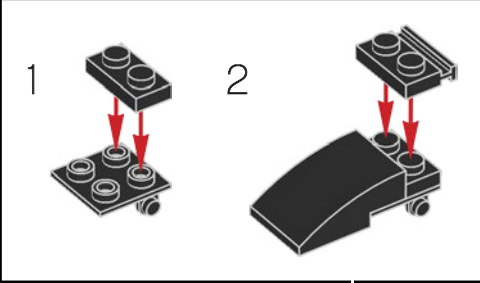

146

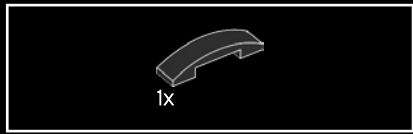
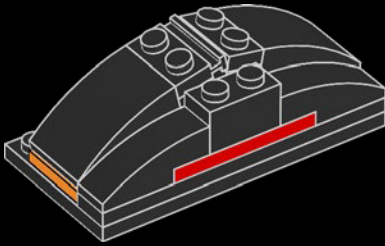

147

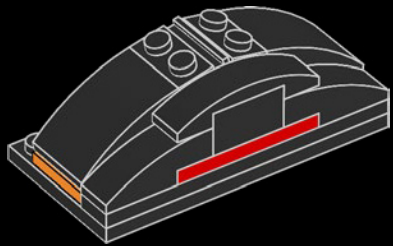

148

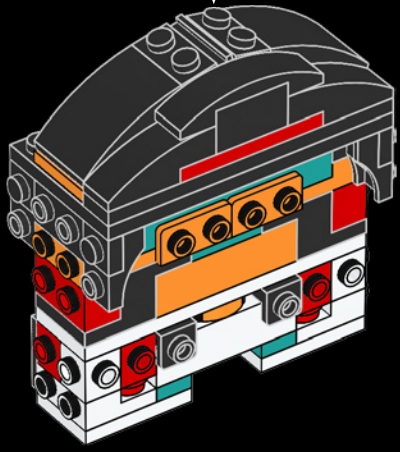

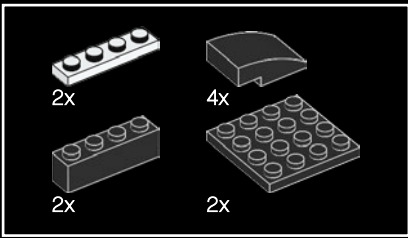

149

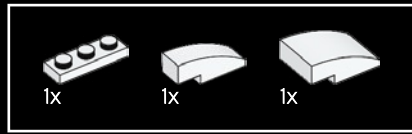
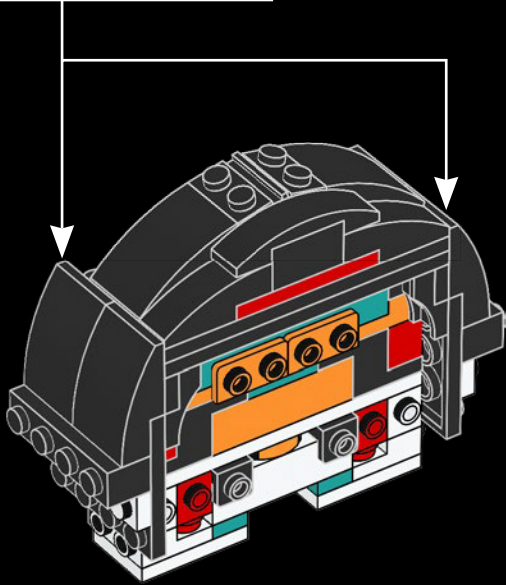
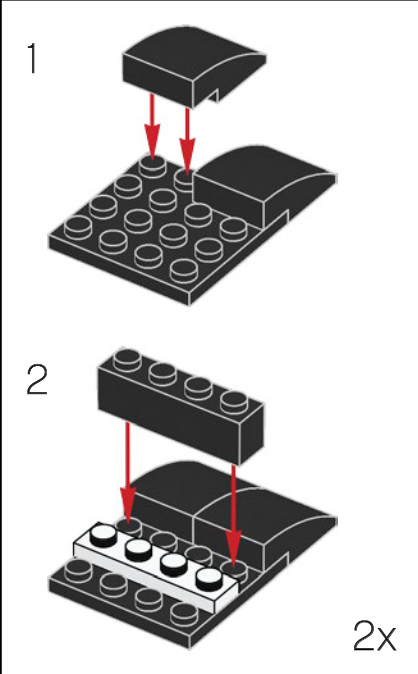

150

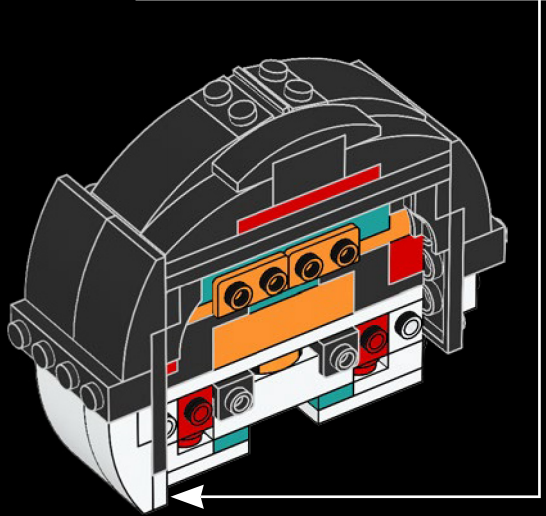
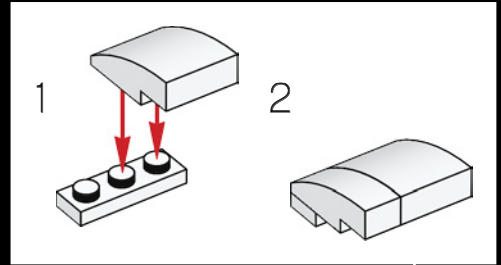

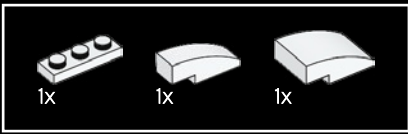

151

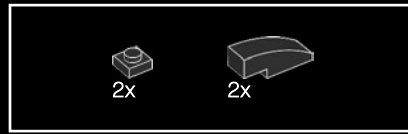
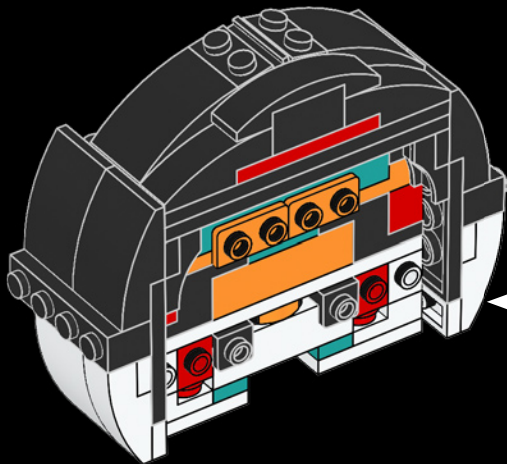
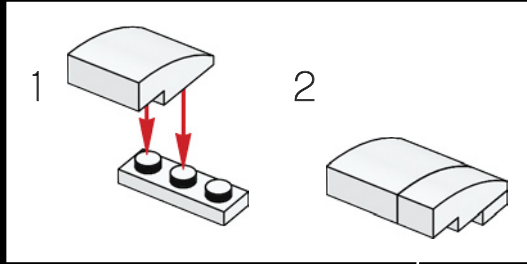

152

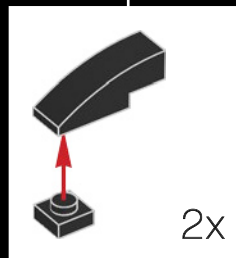
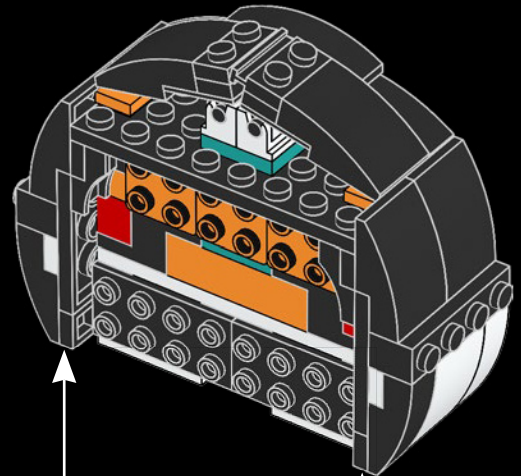

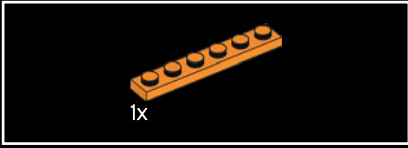
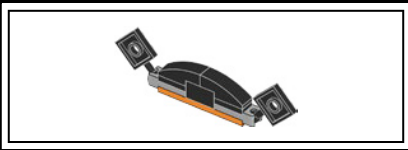

1x

153

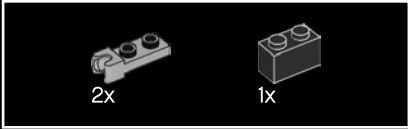

2x

1x

154

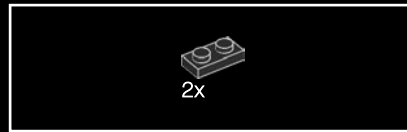
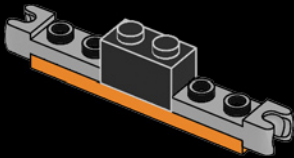

2x

155

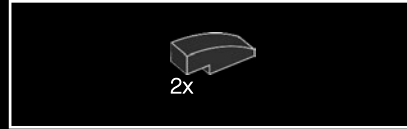
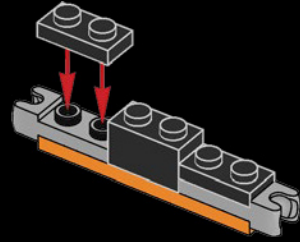

2x

156

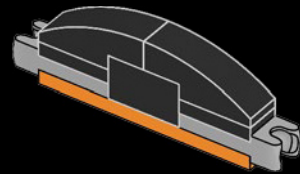

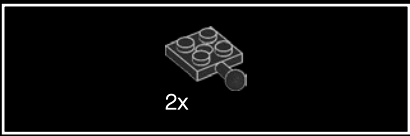

157

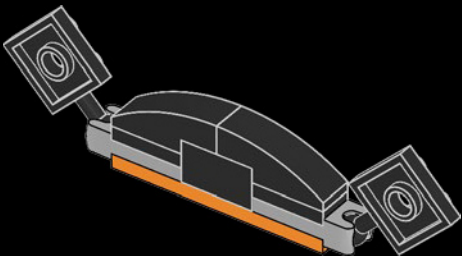

158

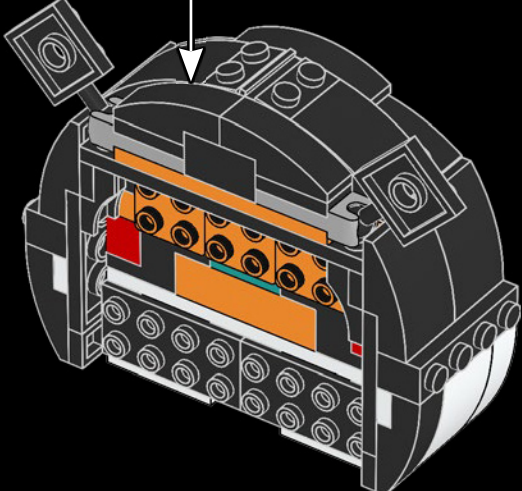

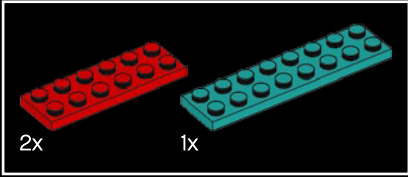
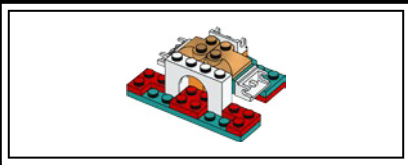

159

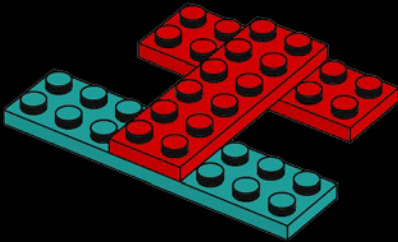

160

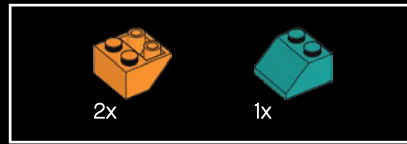
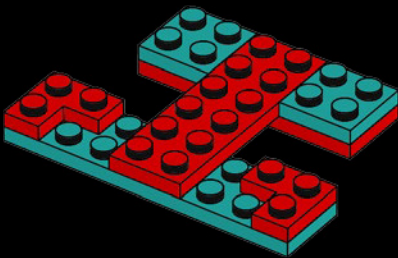

161

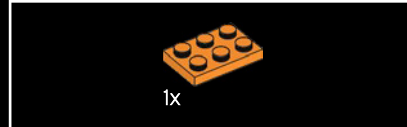
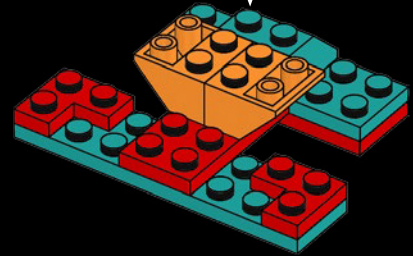
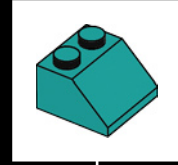

162

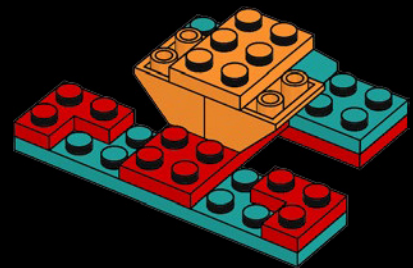

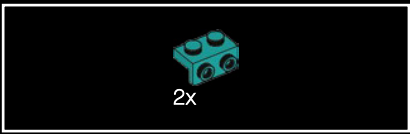

163

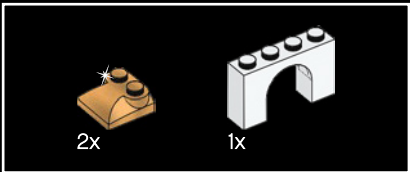
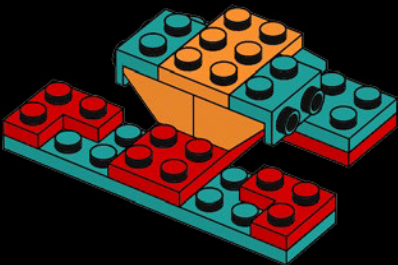

164

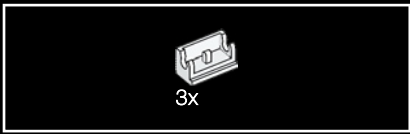
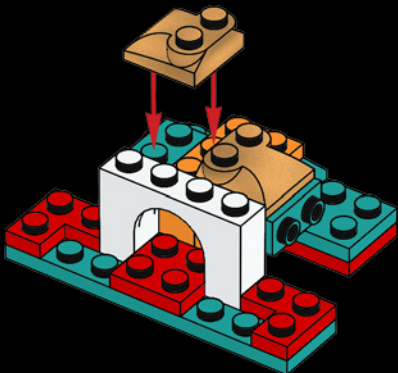

165

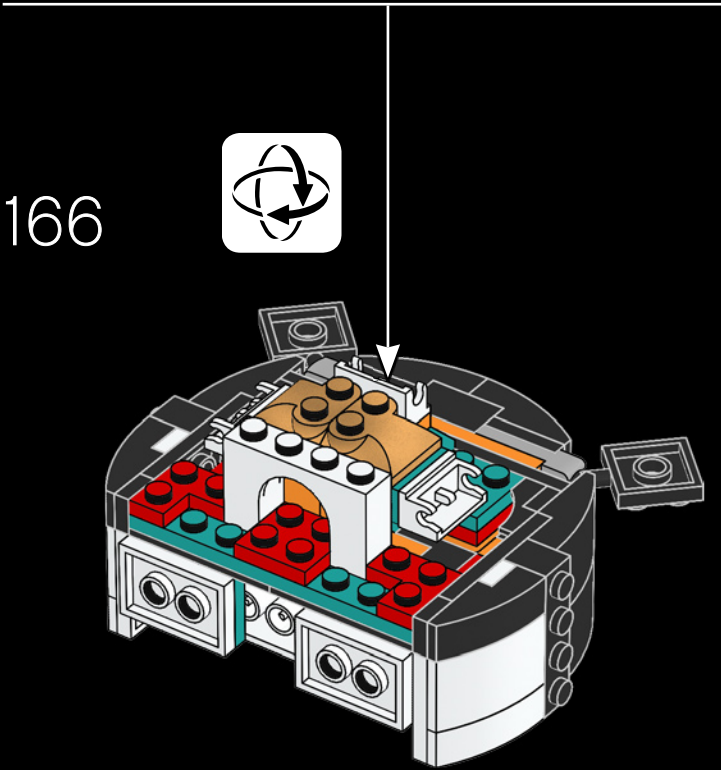
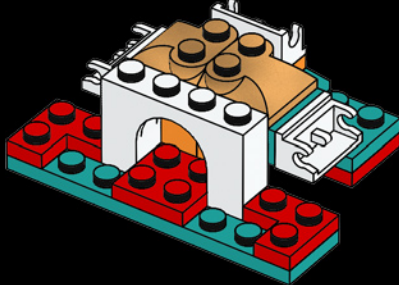

166



167

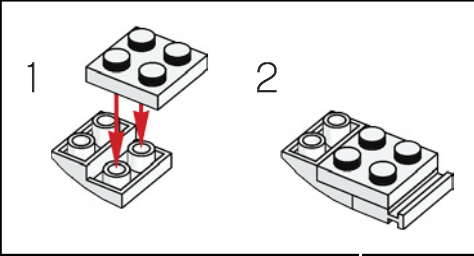

2

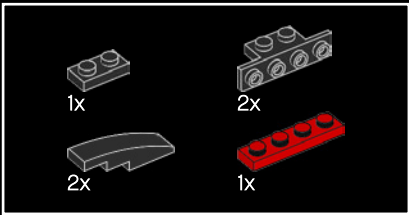
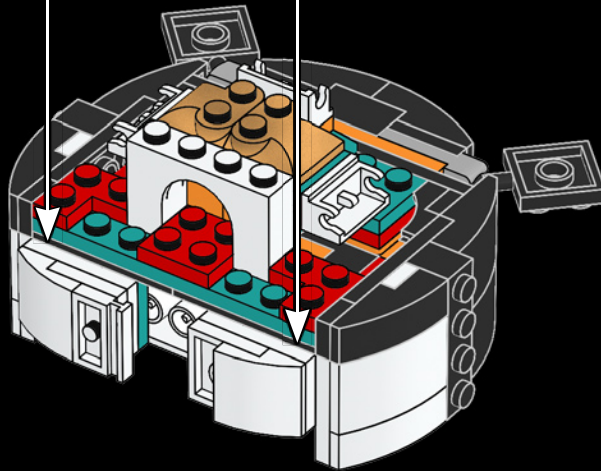
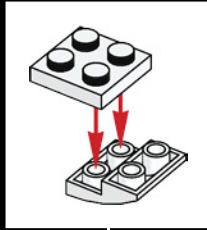
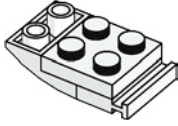

168

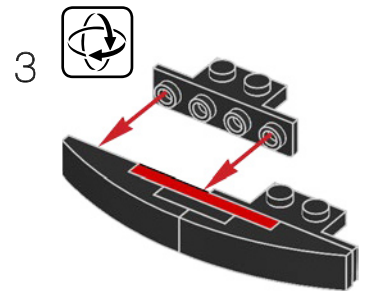
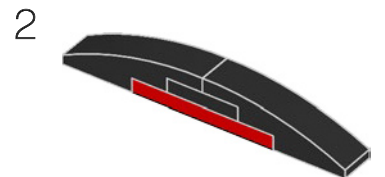
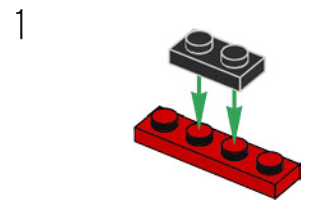
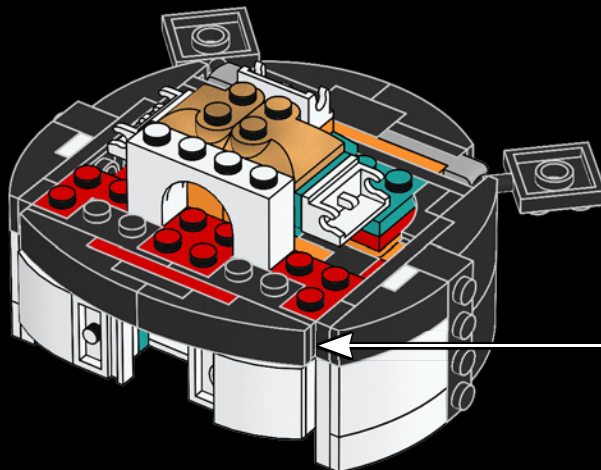

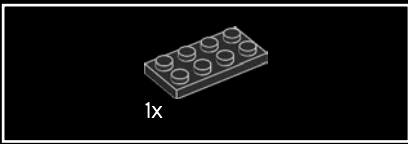

169

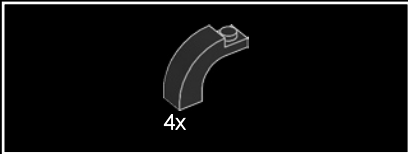
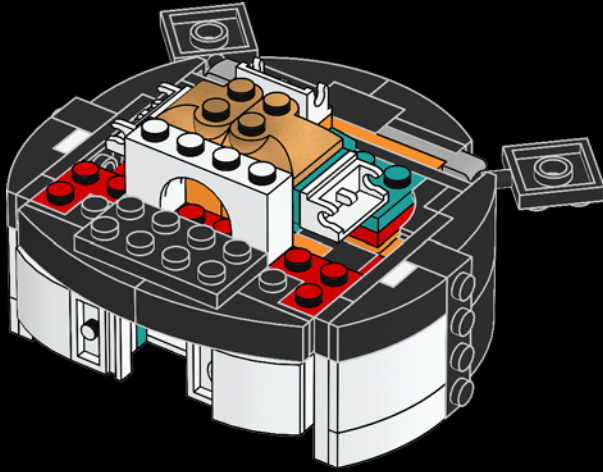

170

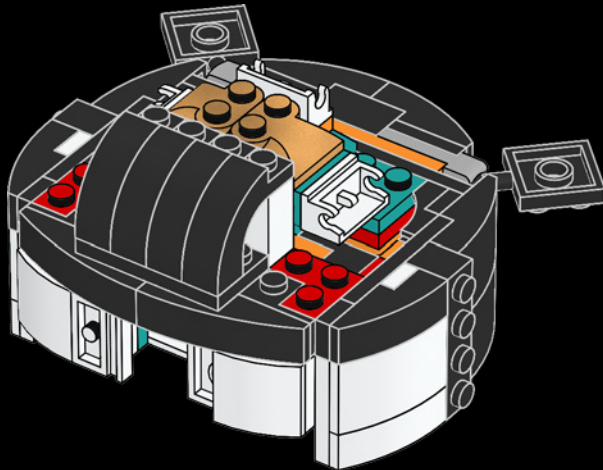



171

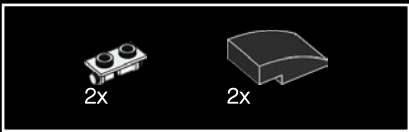
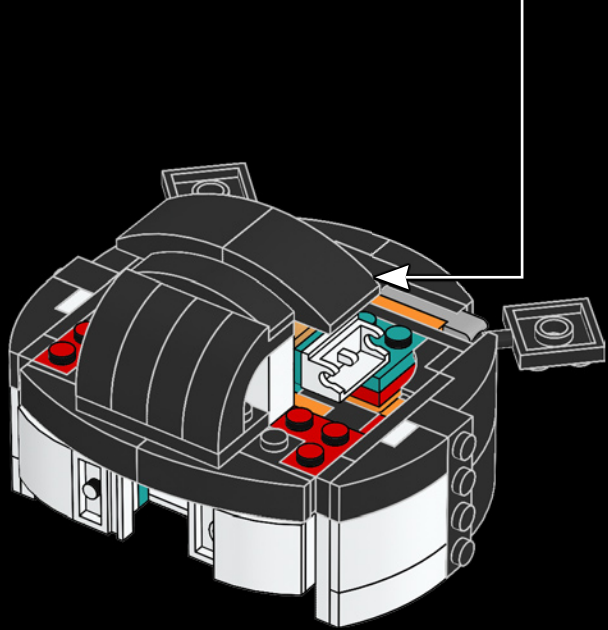
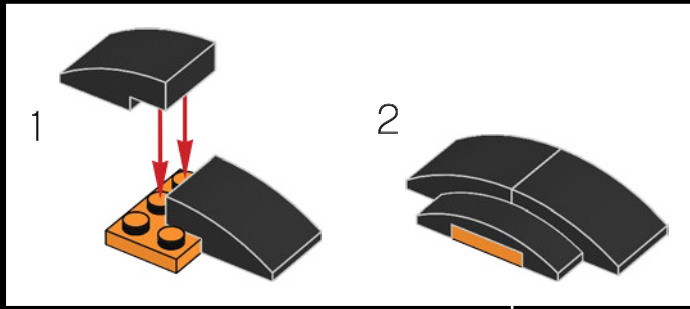

172

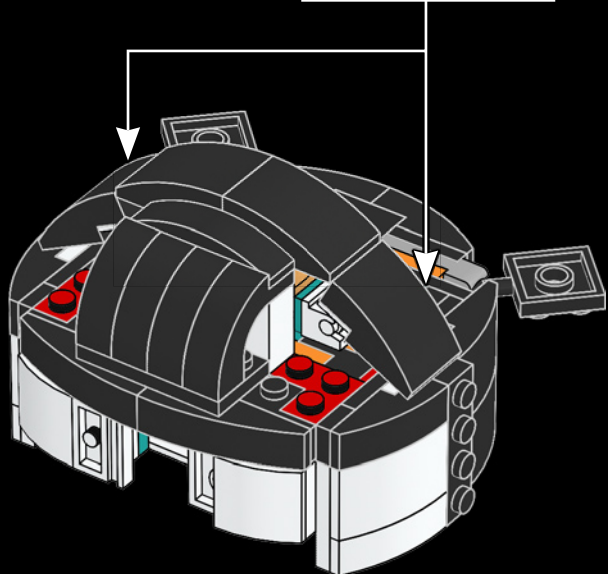
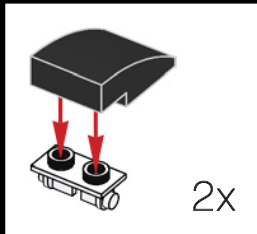

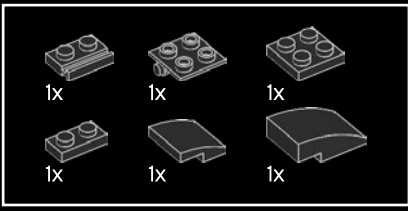

173

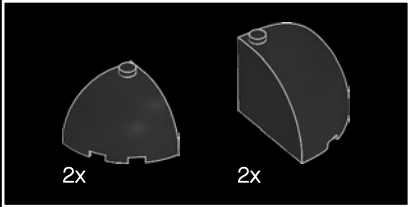
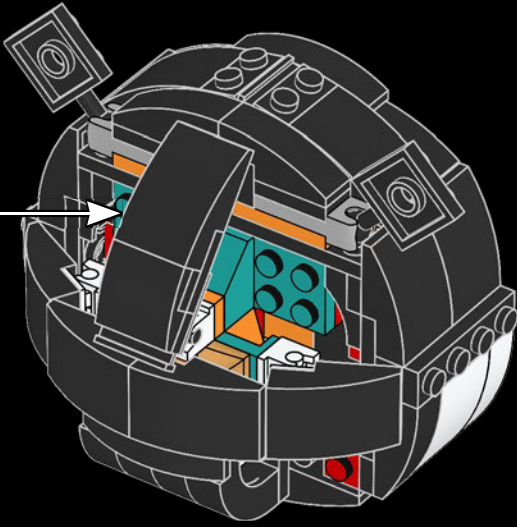
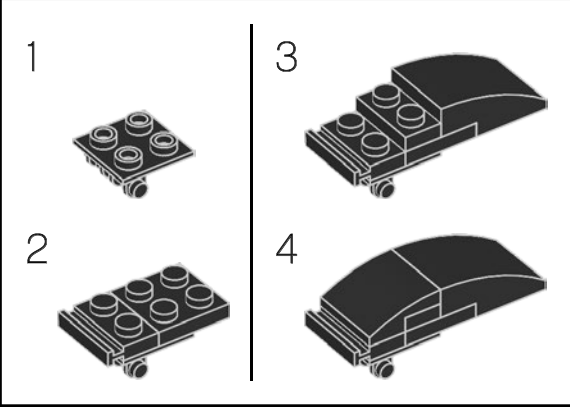

174

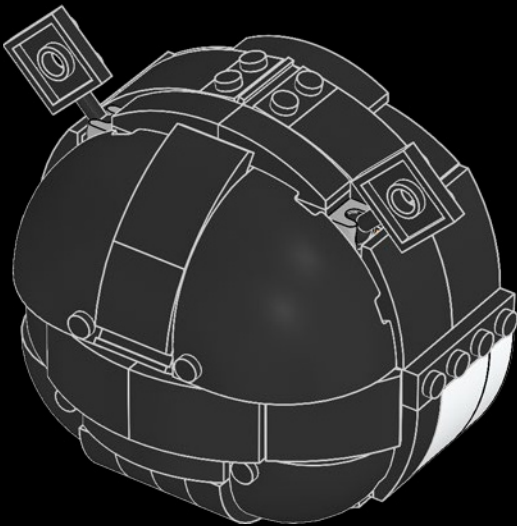

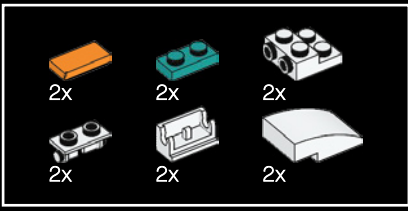

175

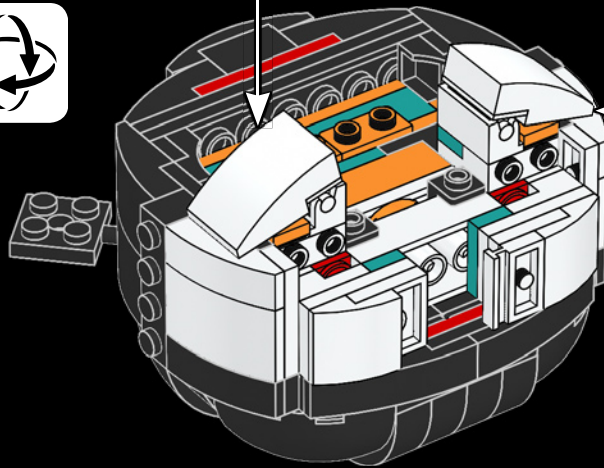
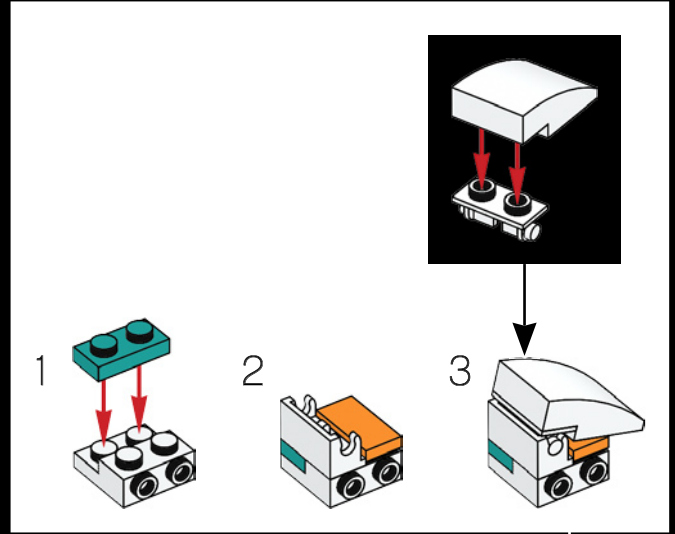
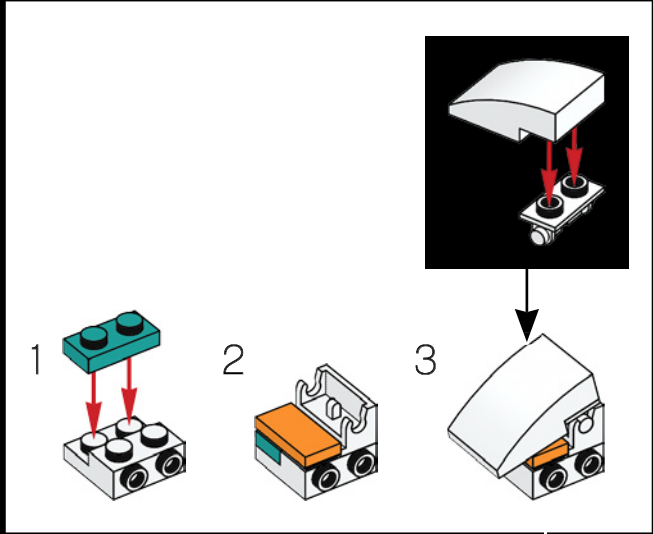

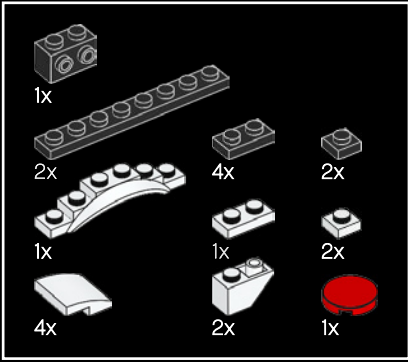
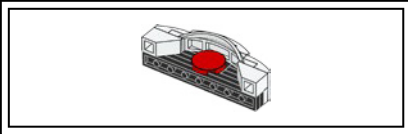

176

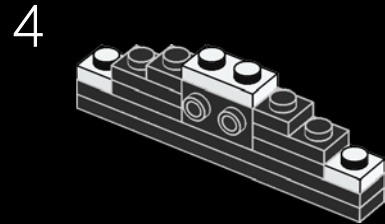
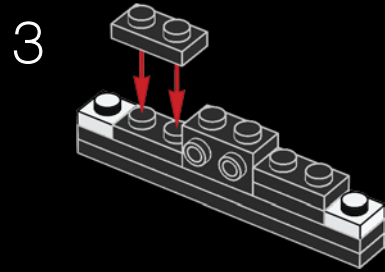
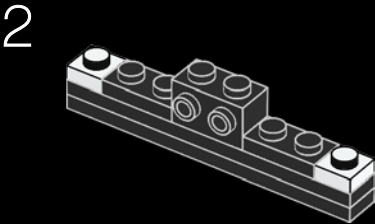
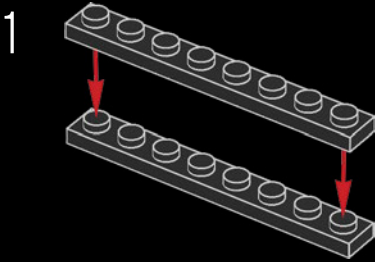

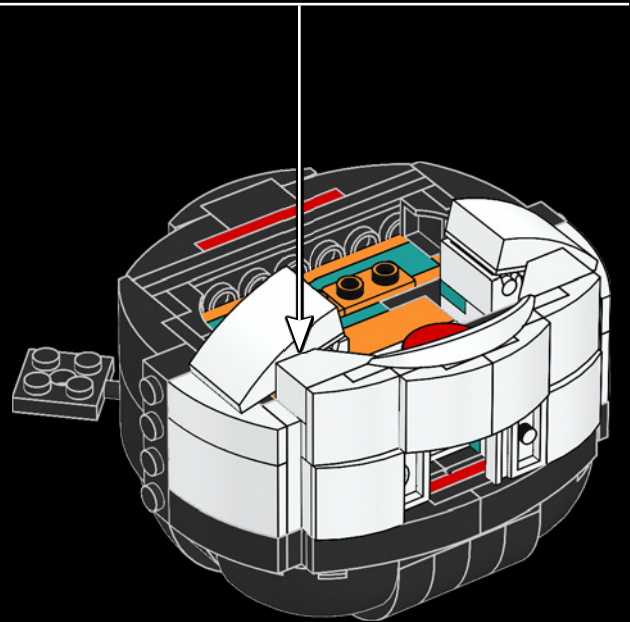
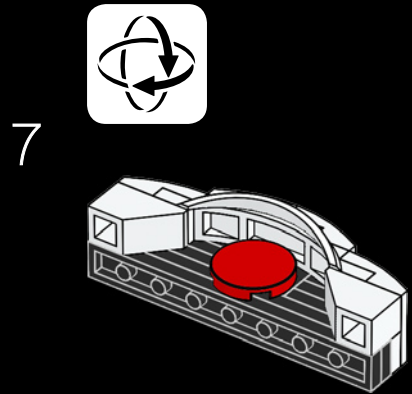
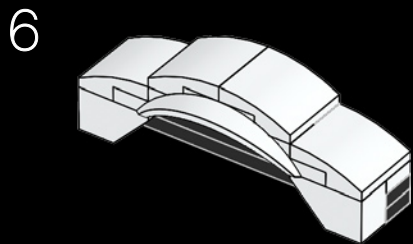
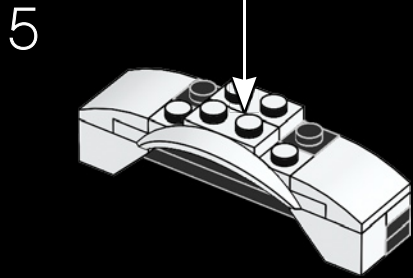
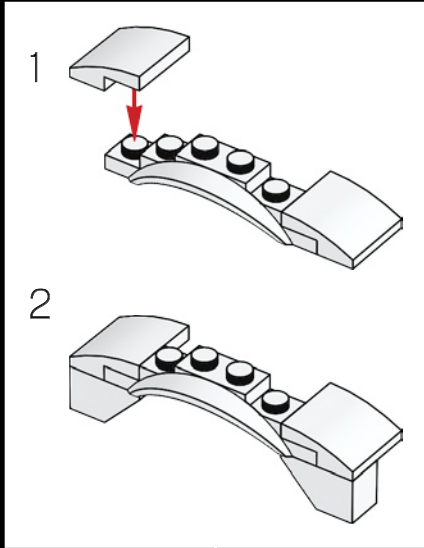

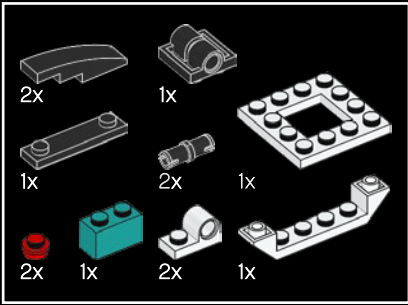

177

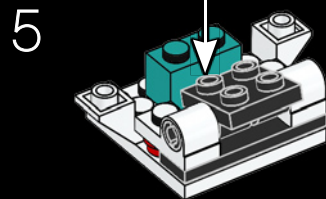
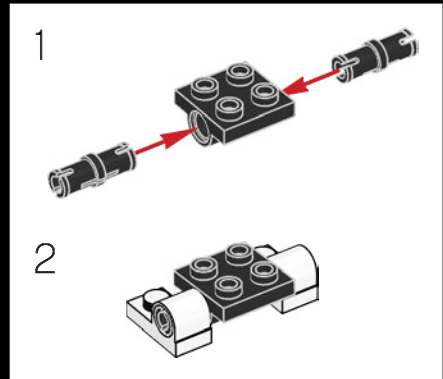
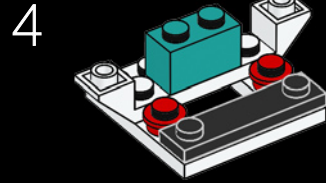
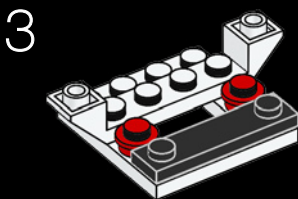
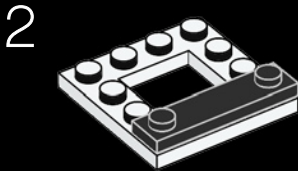
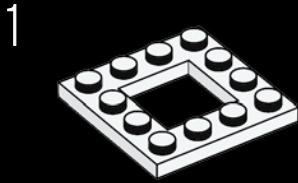

6

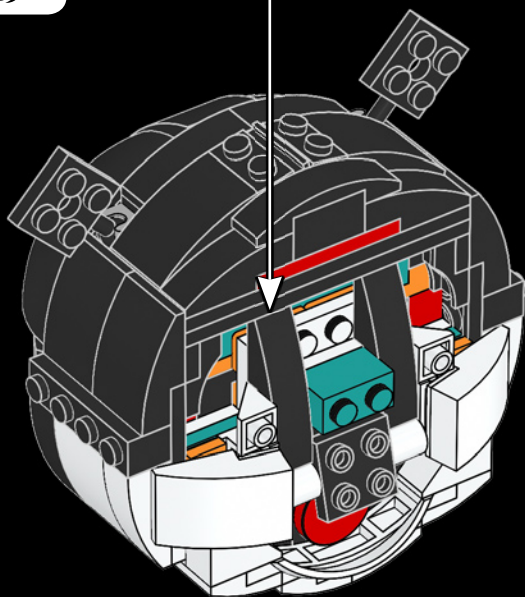
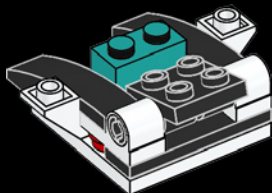

178

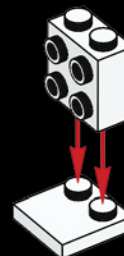

179

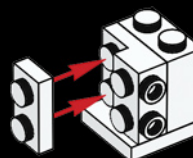

180

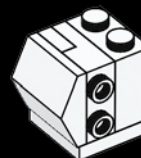

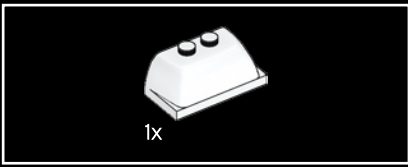

181

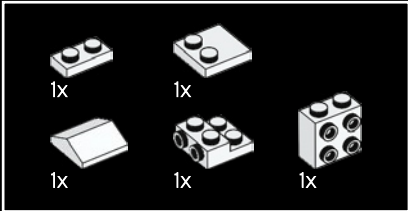

182

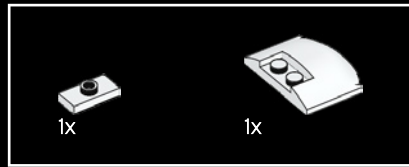
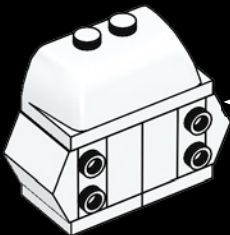
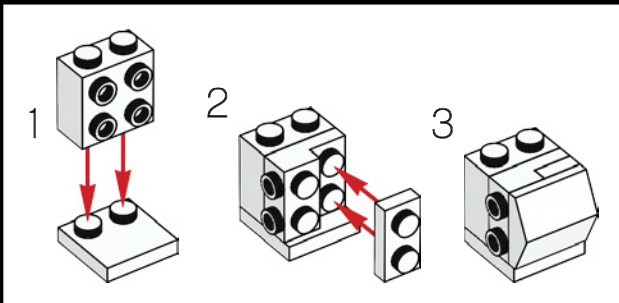

183



184

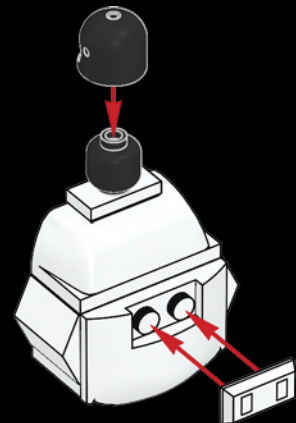

185

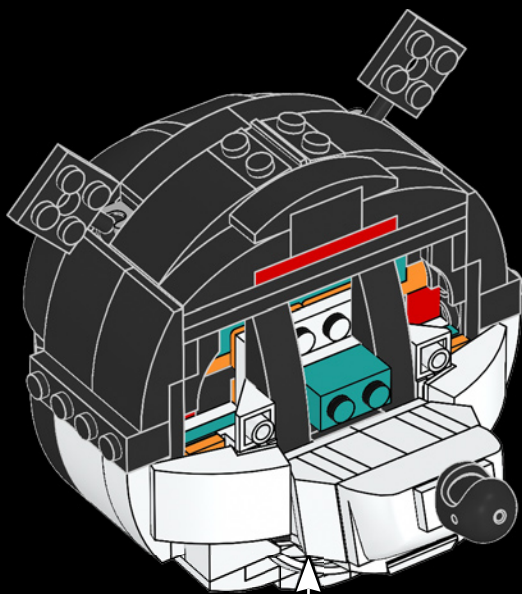

186

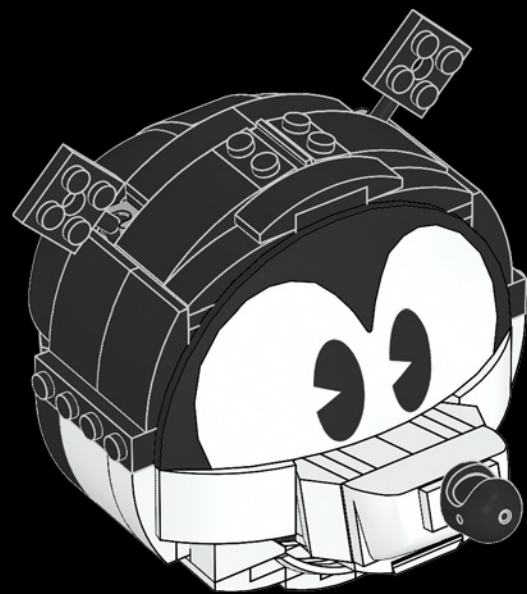

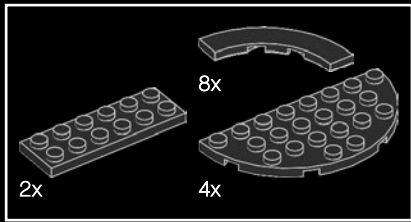

187

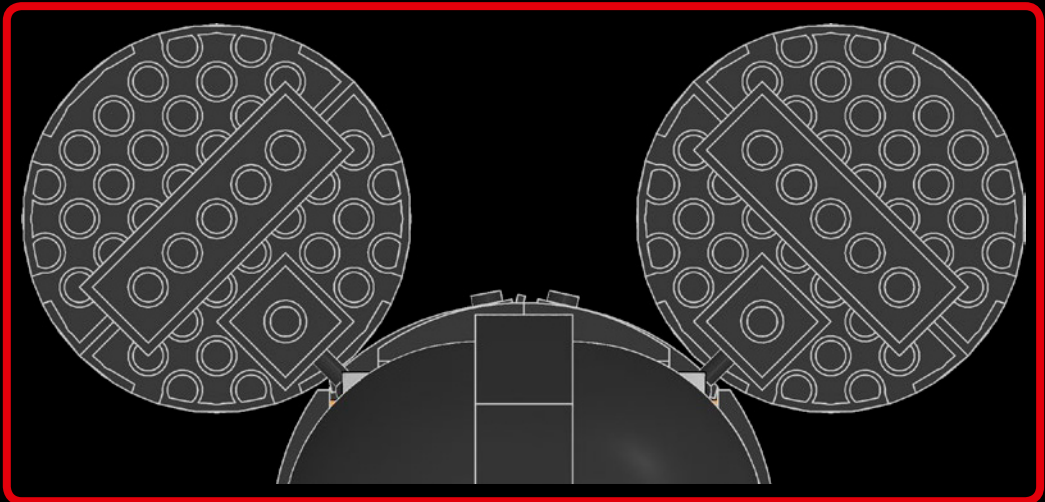
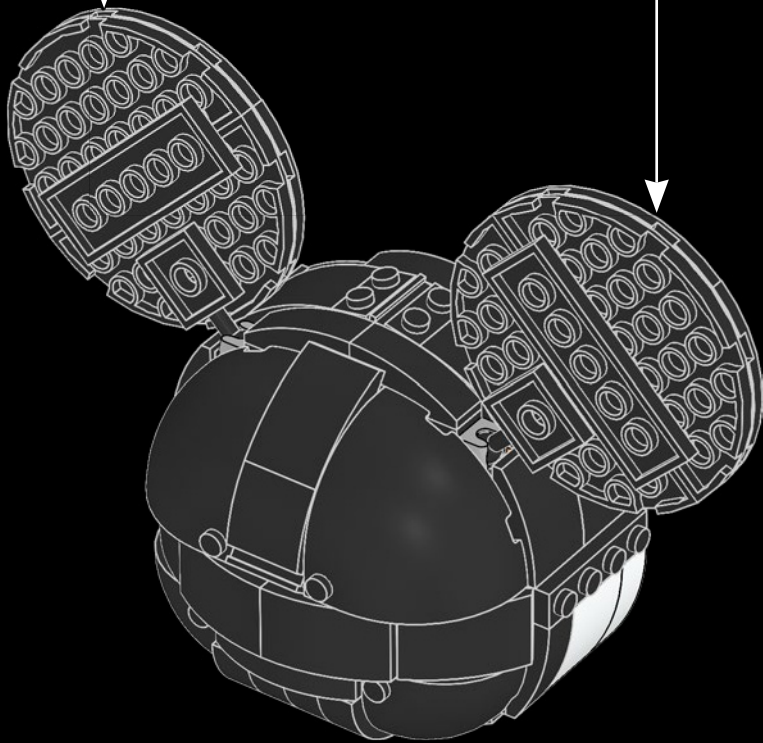
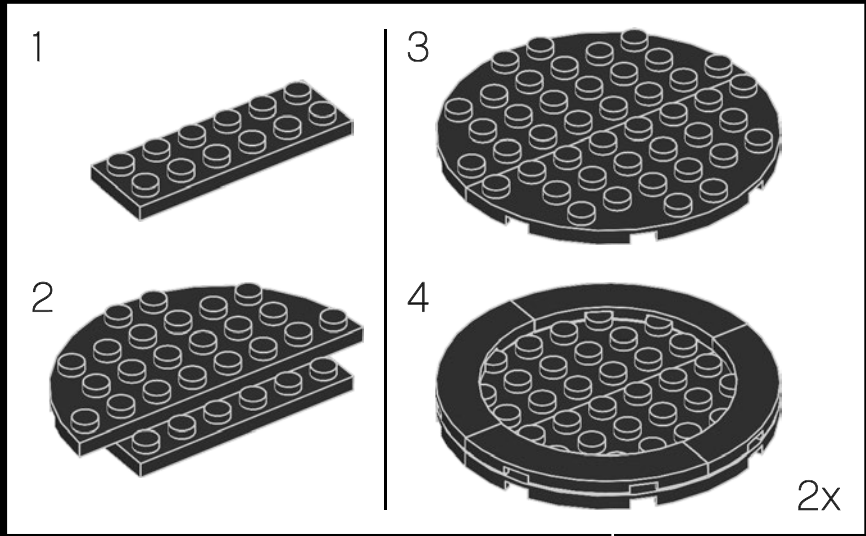

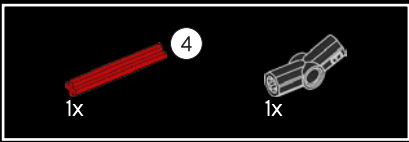

188

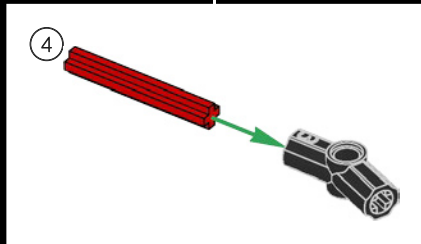
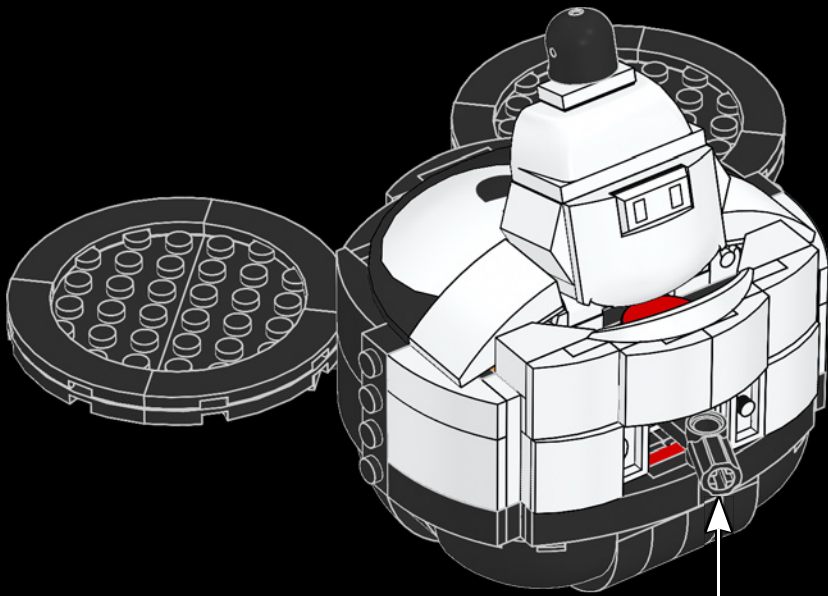

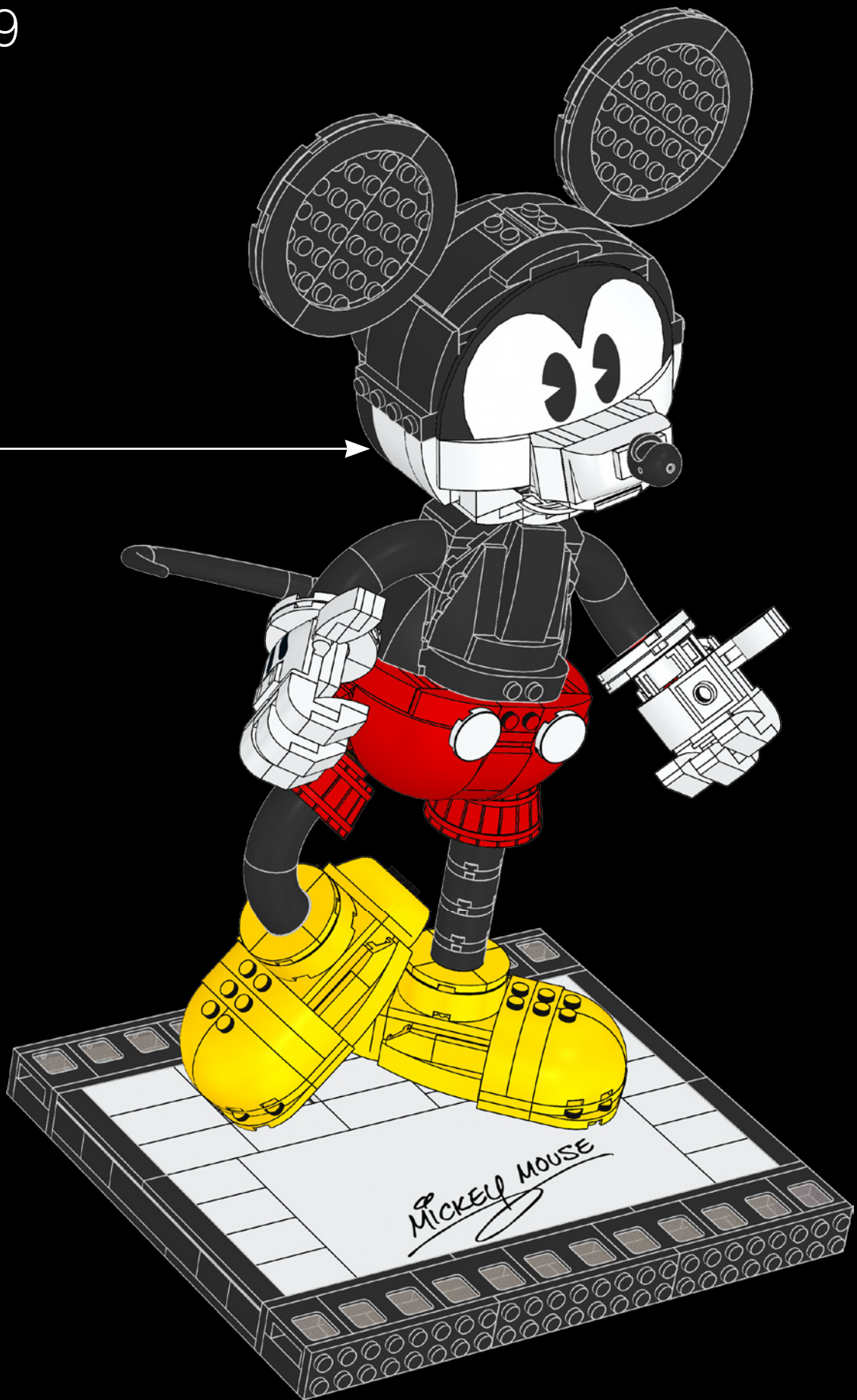

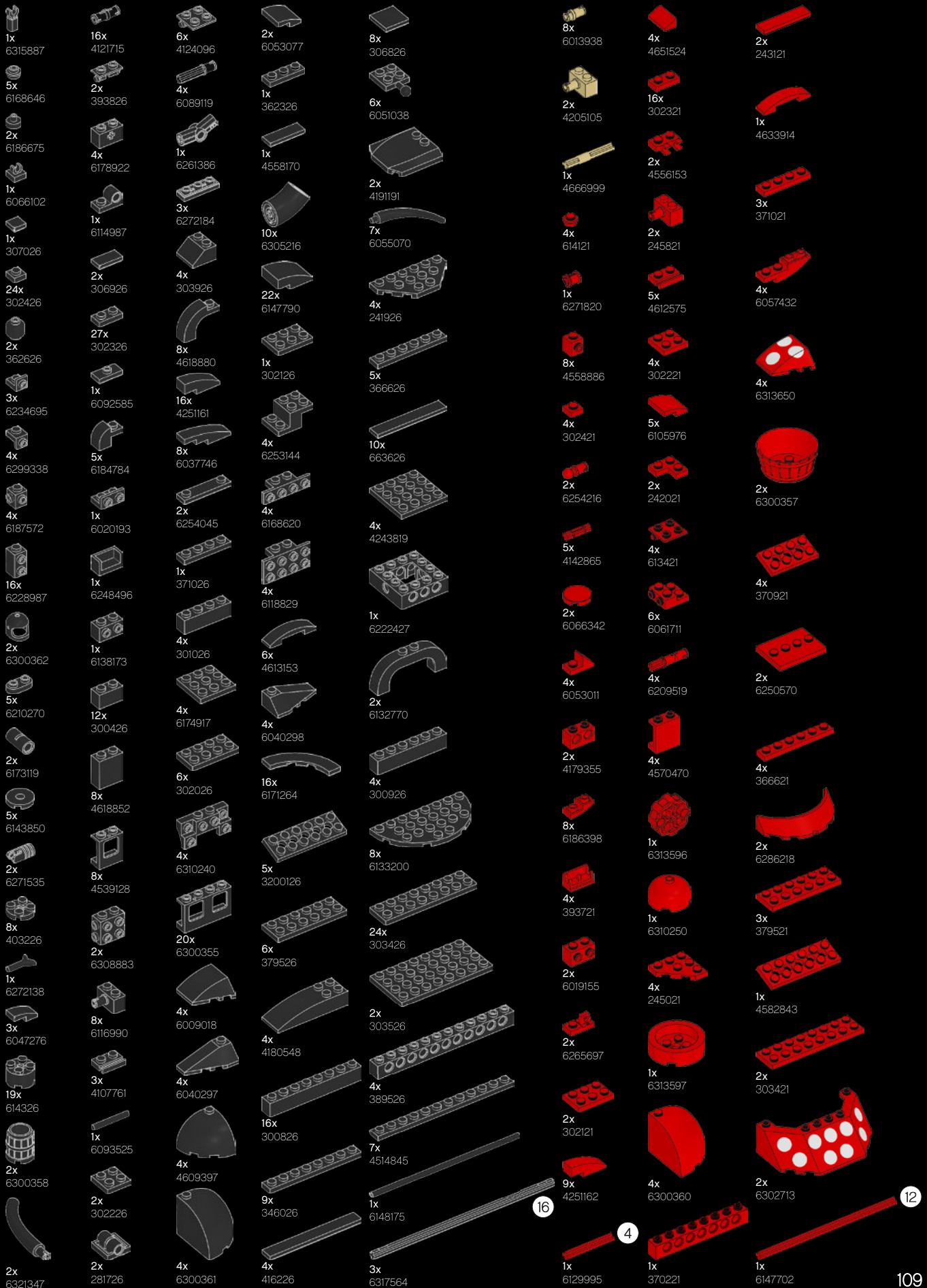

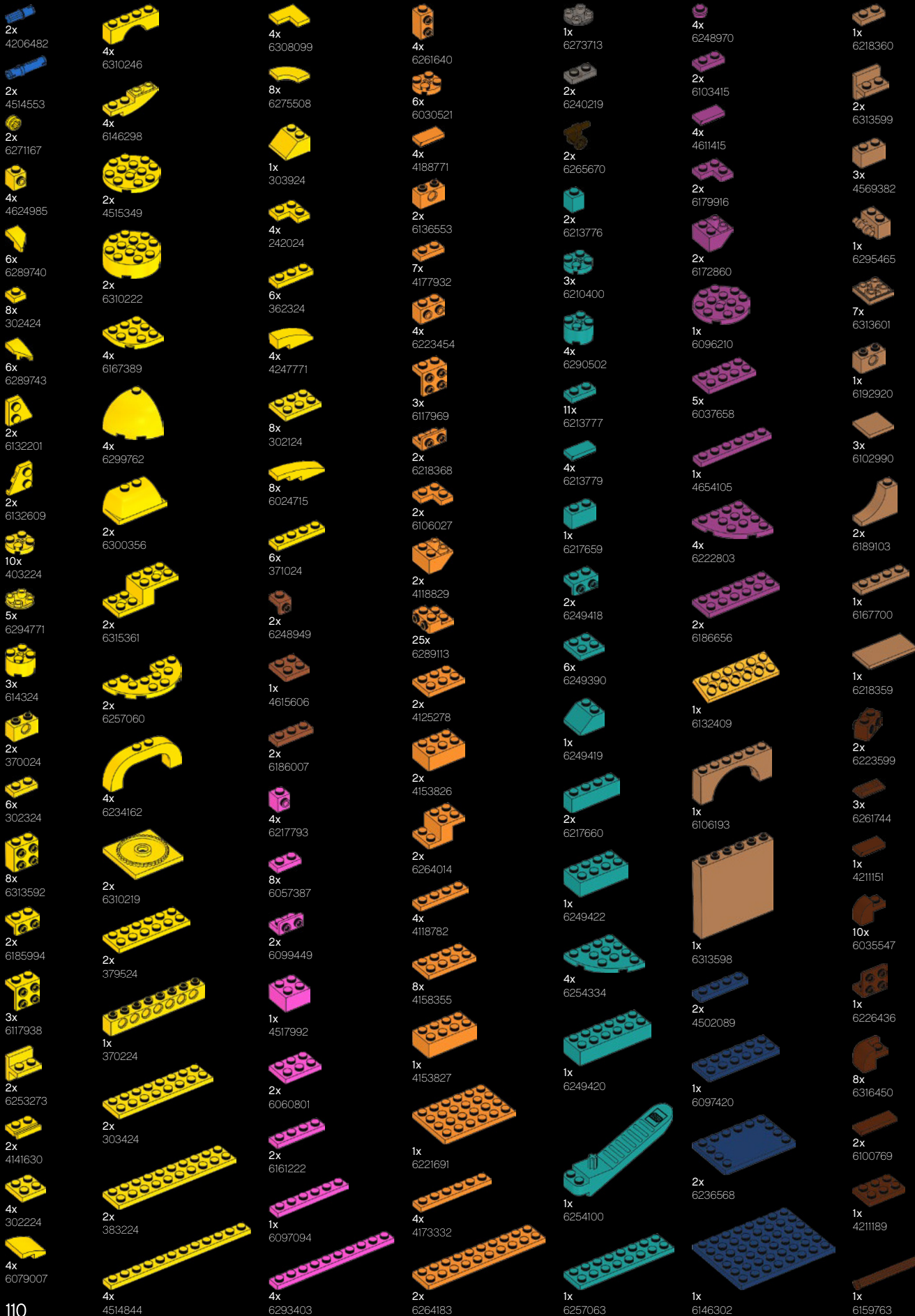



3,2

4

5,5



Customer Service
Kundenservice
Service Consommateurs
Servicio Al Consumidor
LEGO.com/service or dial

: 00800 5346 5555
 : 1-800-422-5346

