

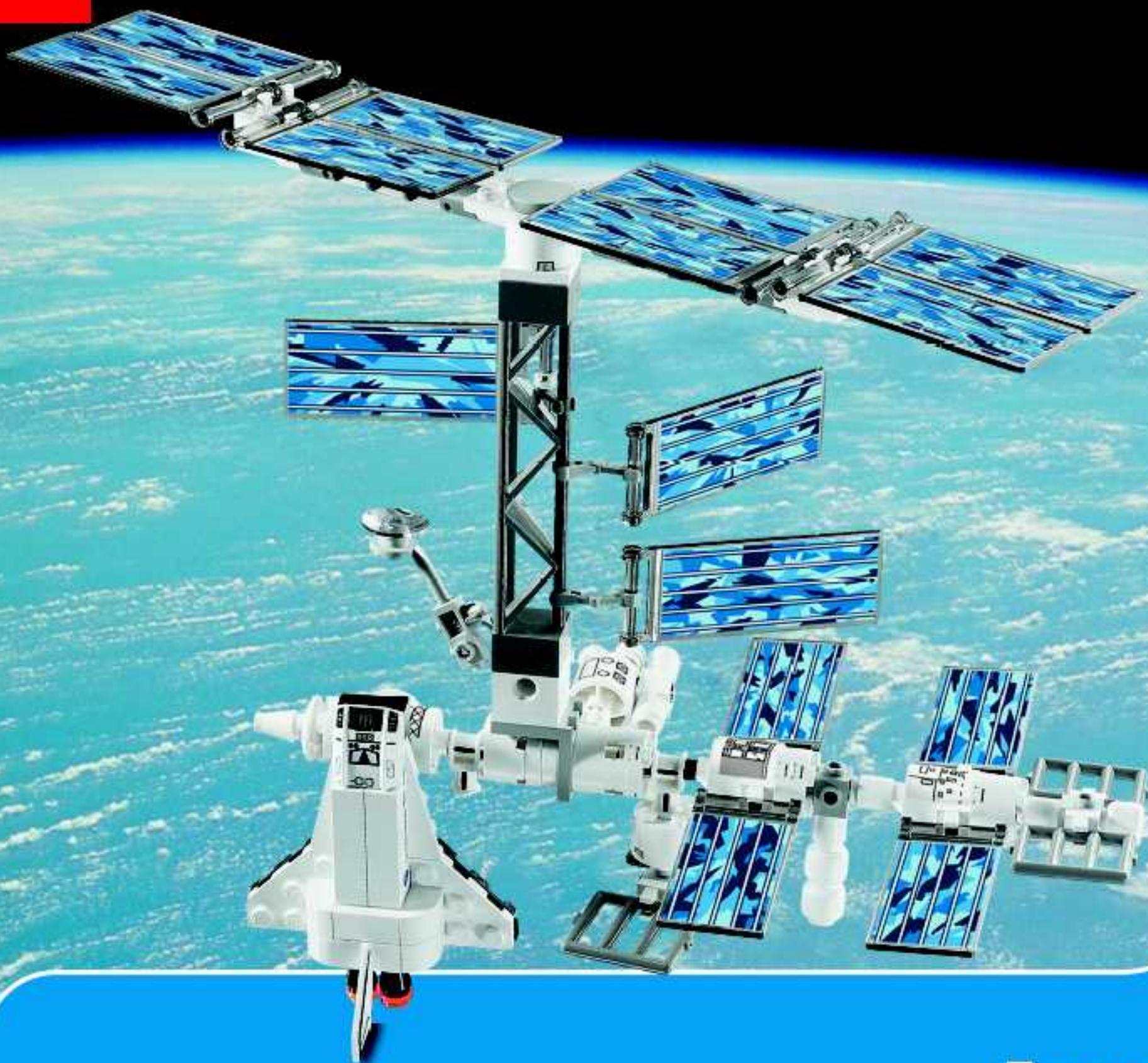

7467



4216698





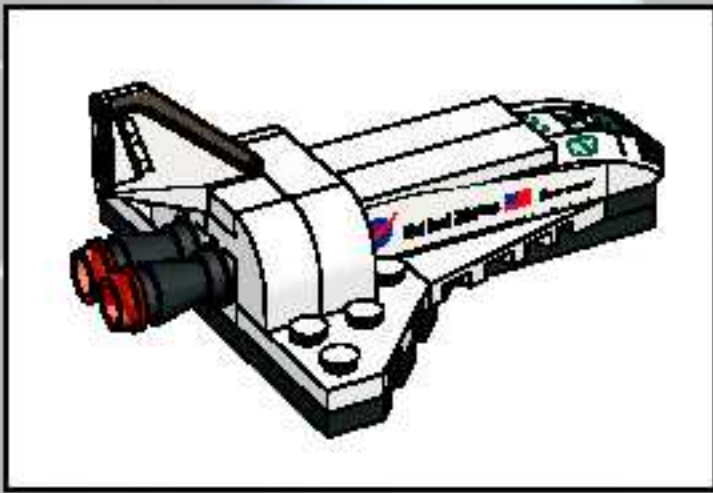

1

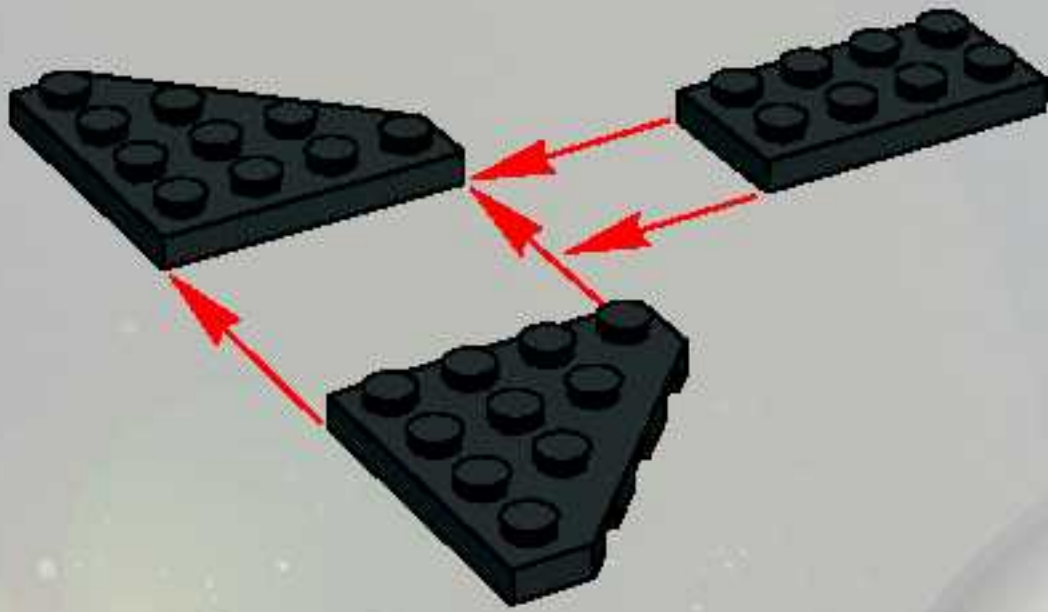

2

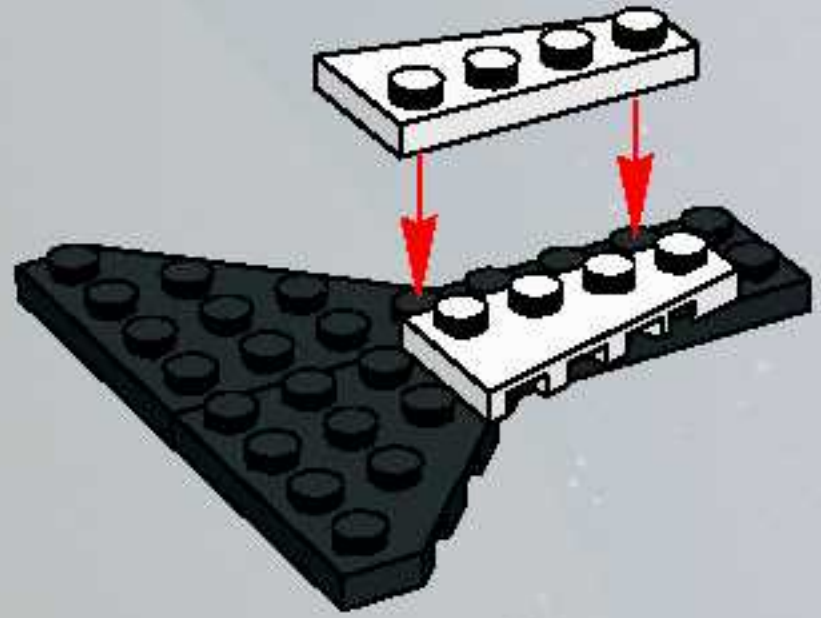

3

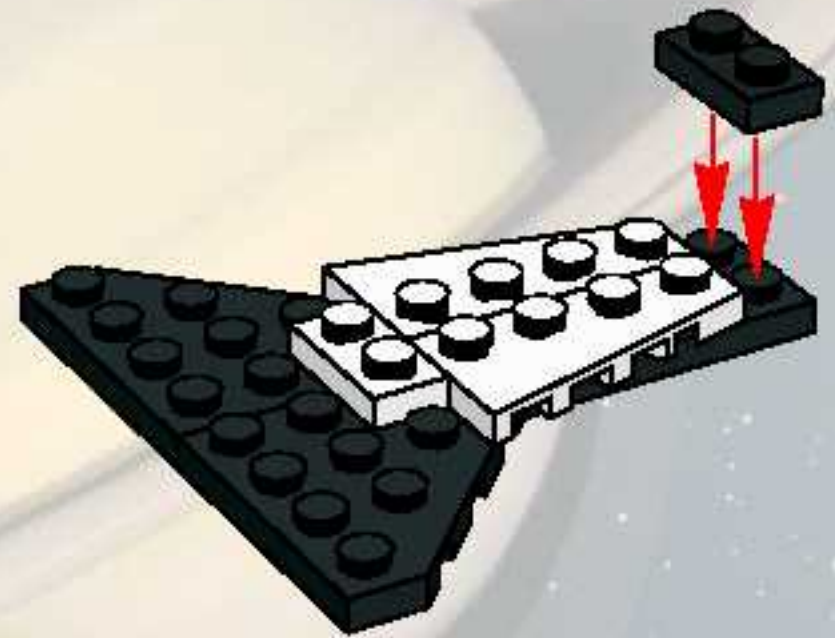

4

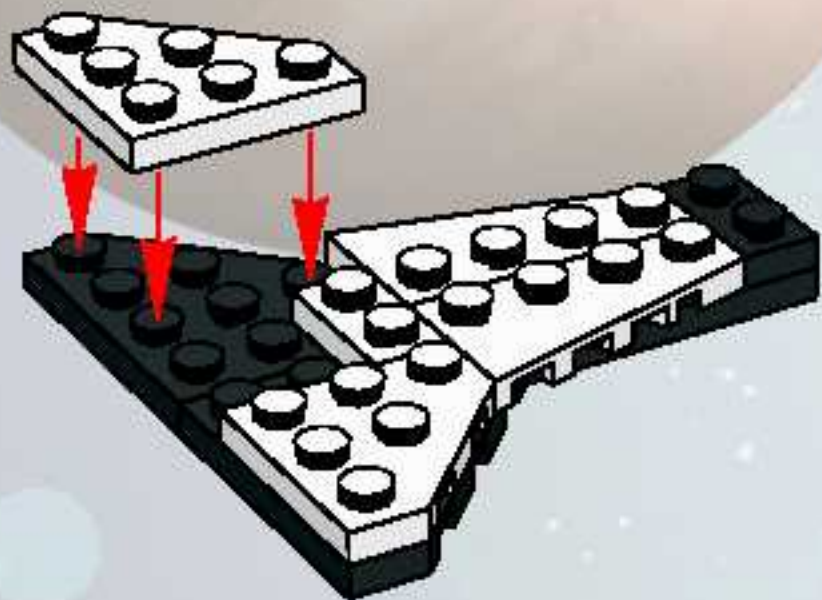

6

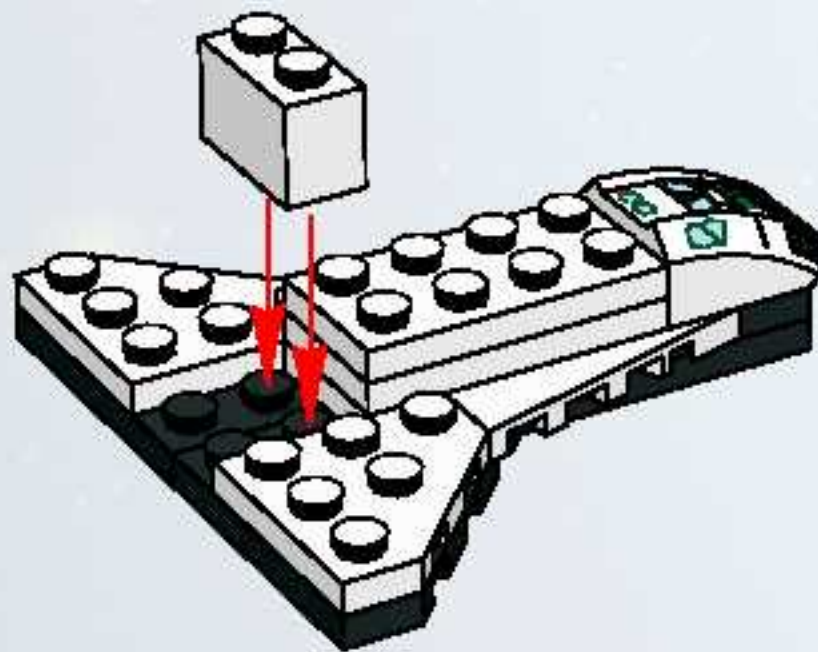

5

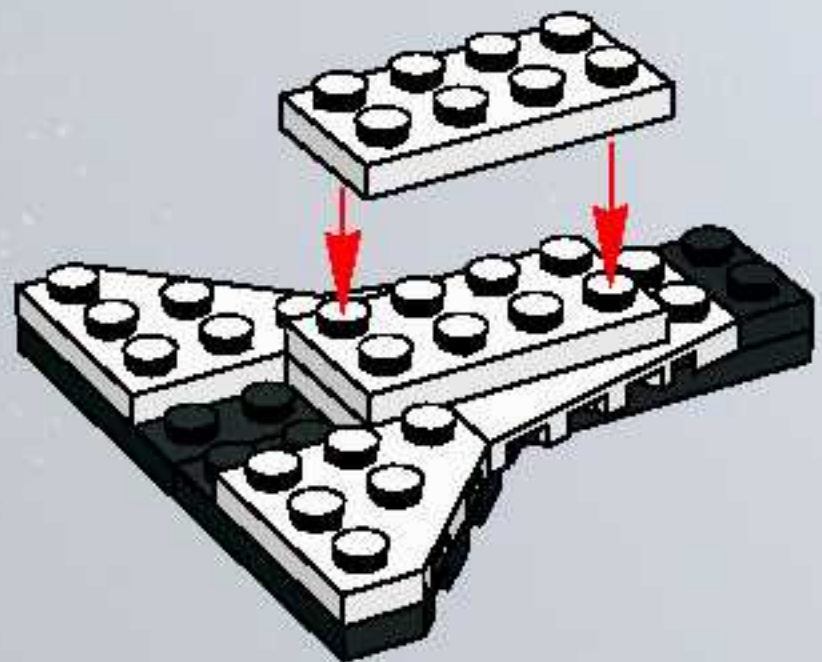

7

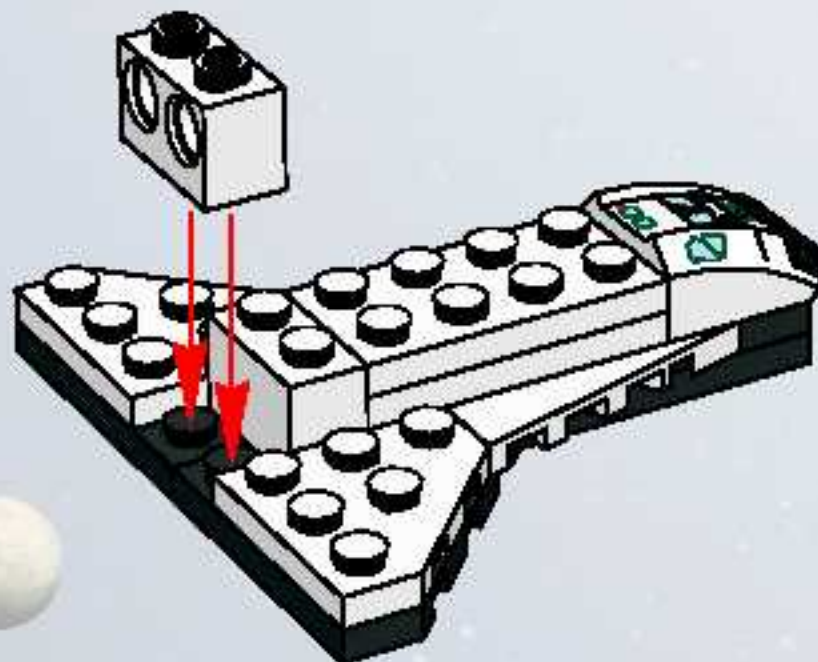



8

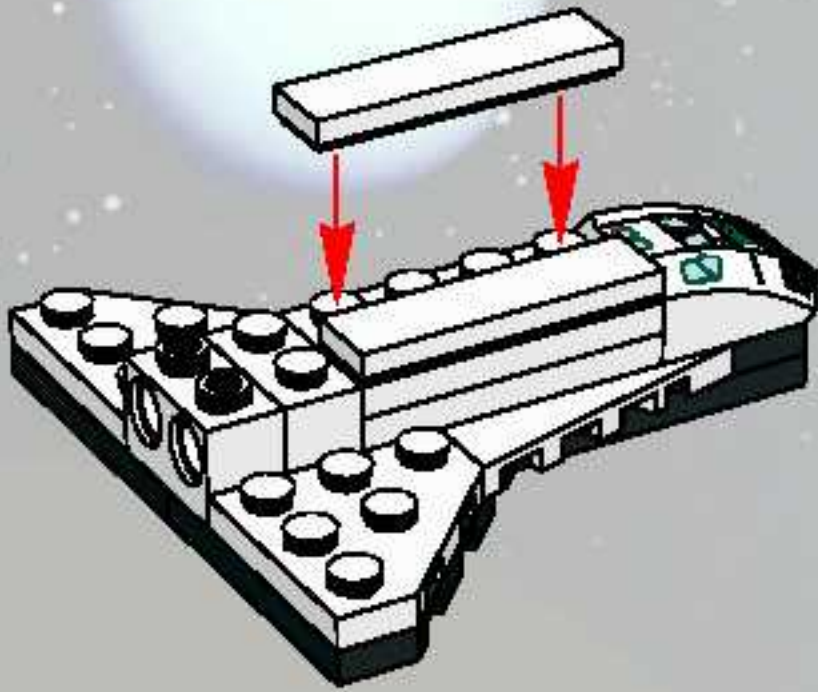

10

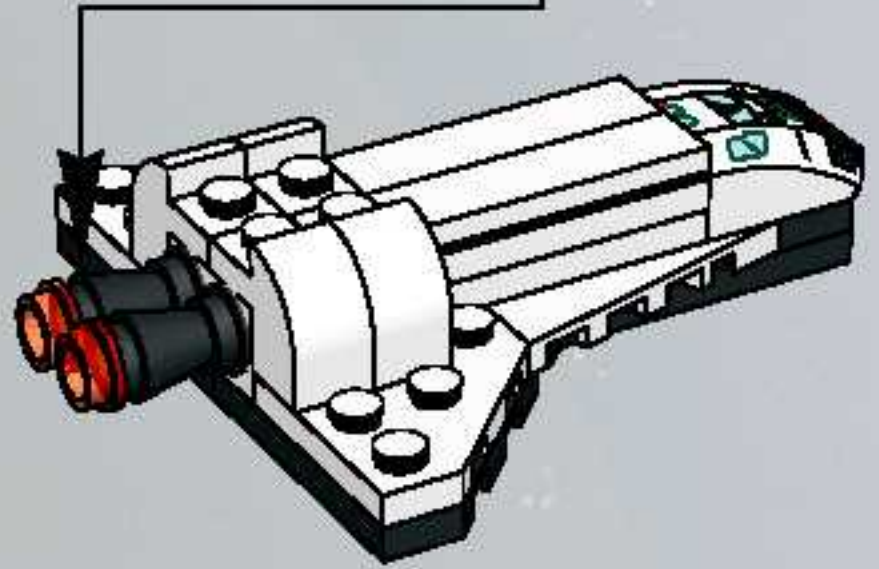
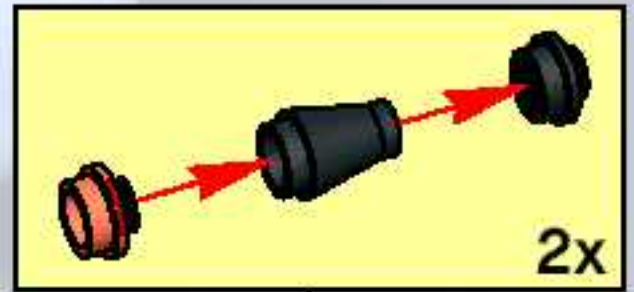

9

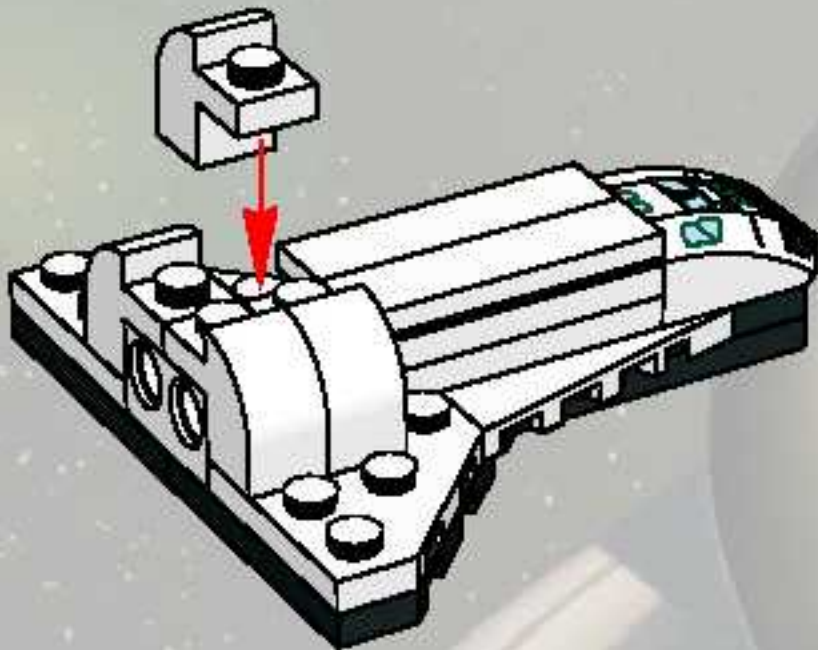

11

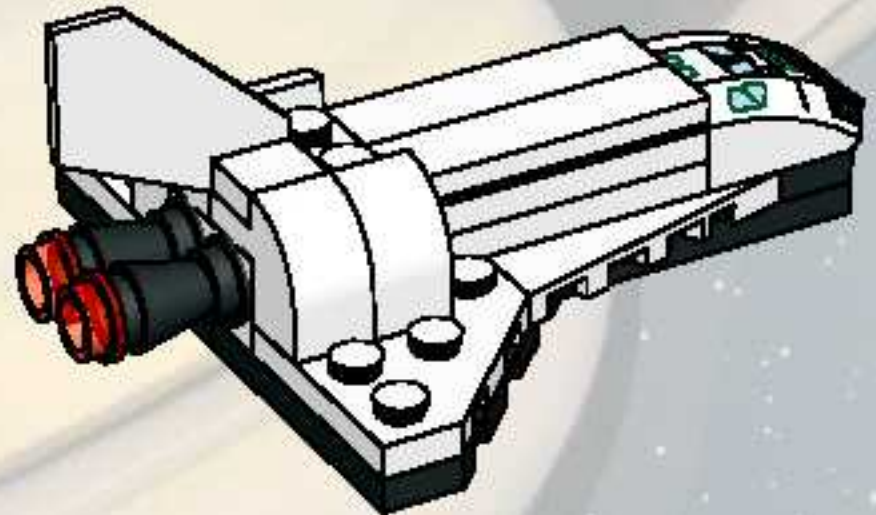

12

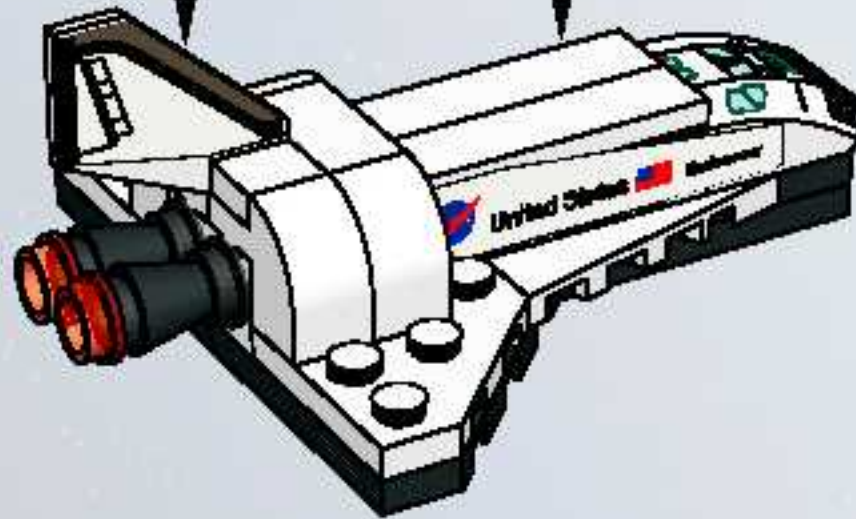
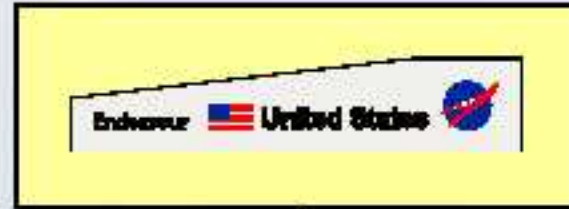
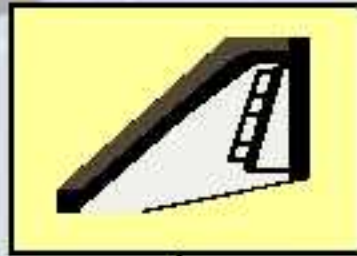



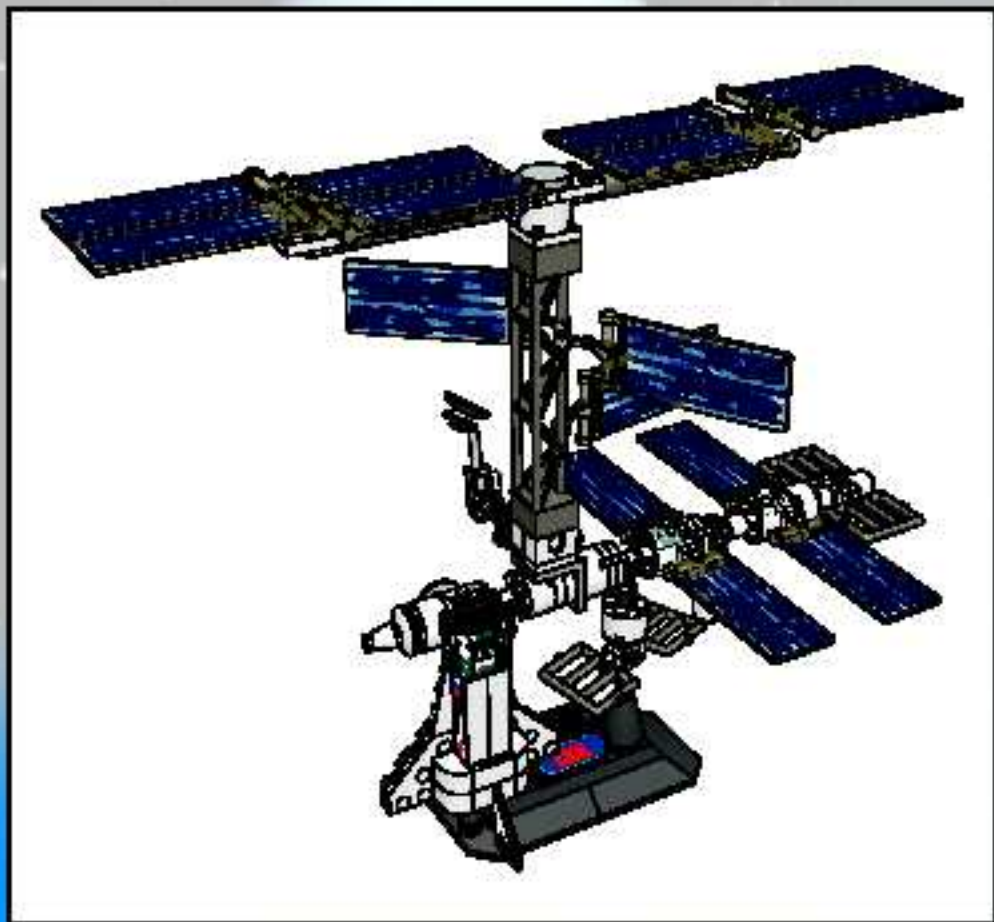

1



2

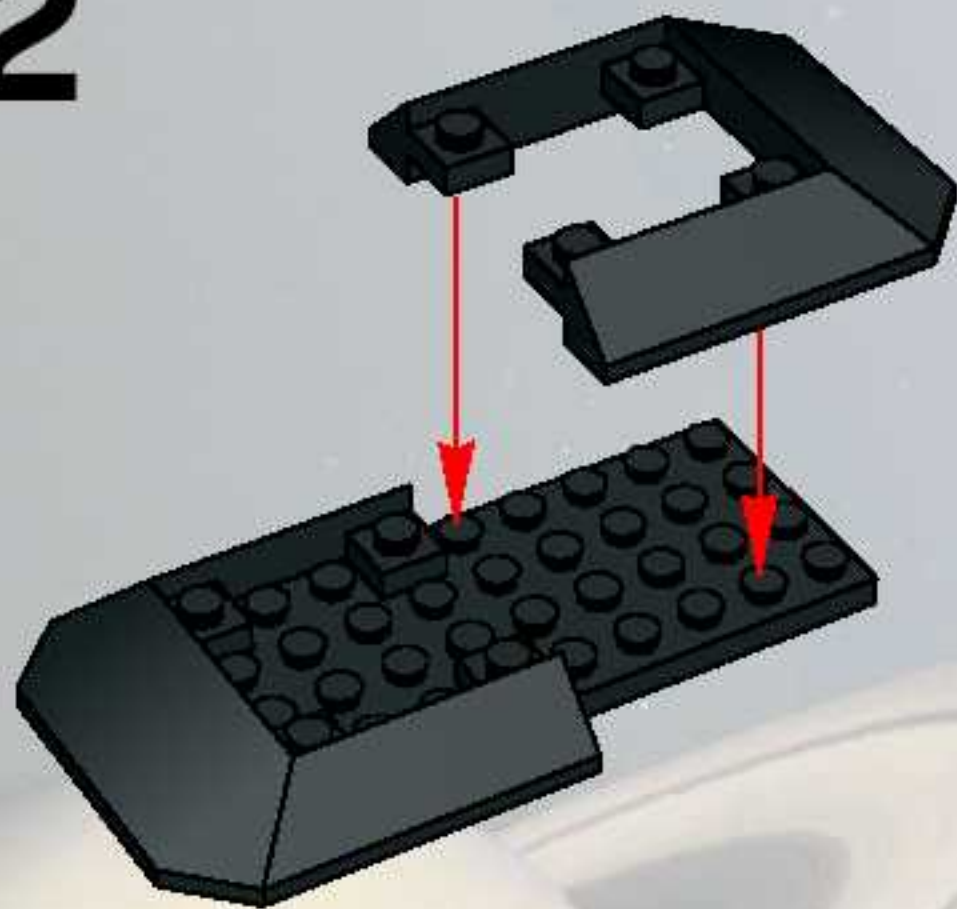

3

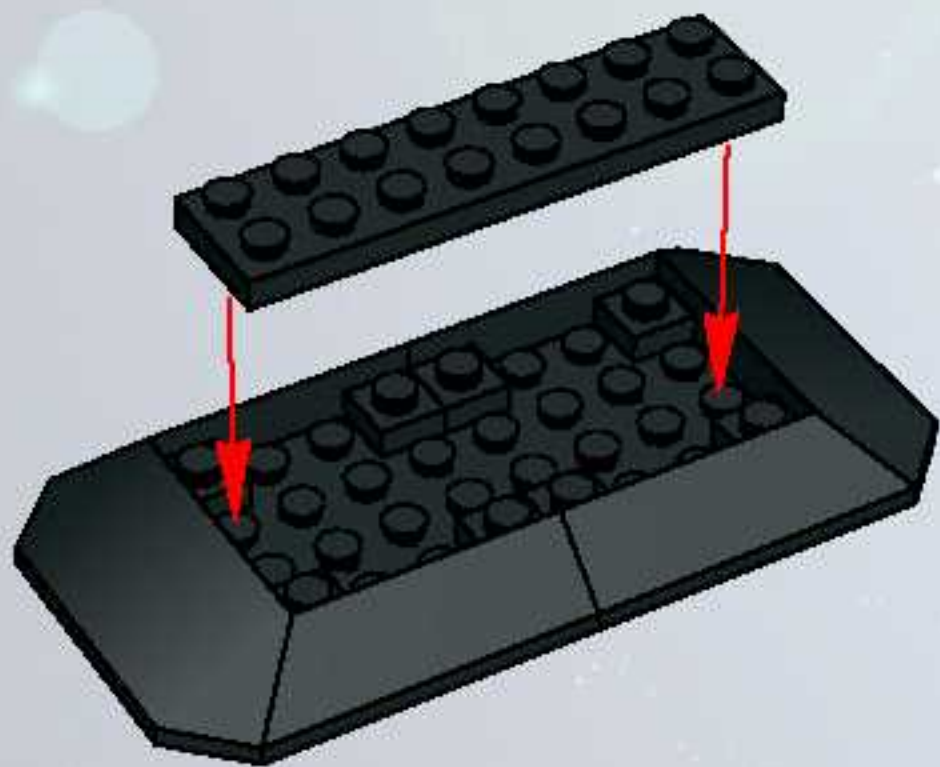

4

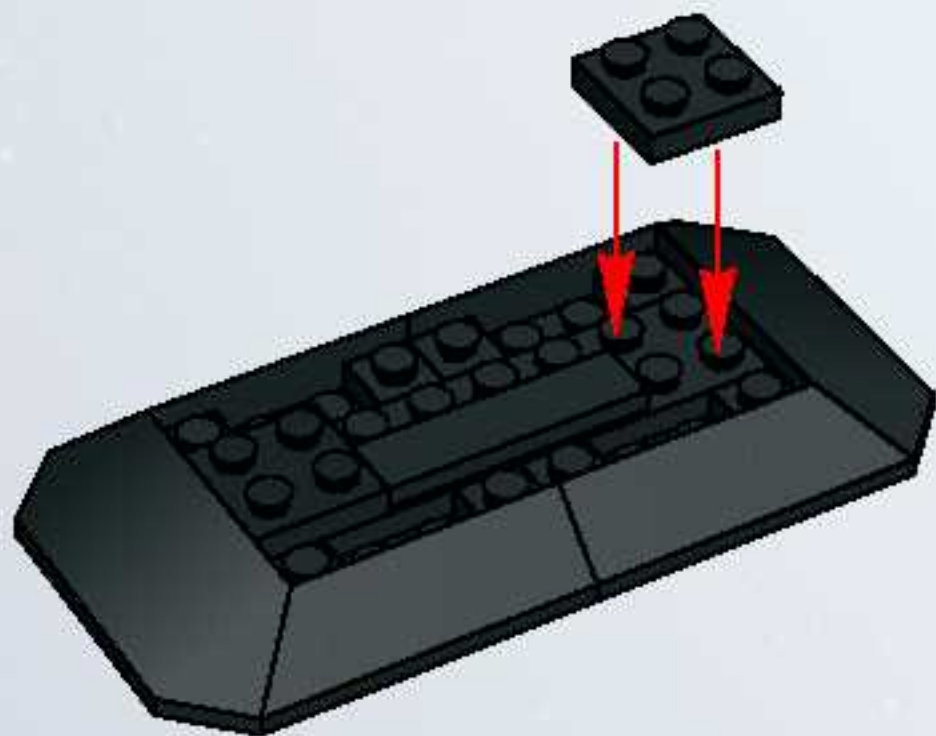

5

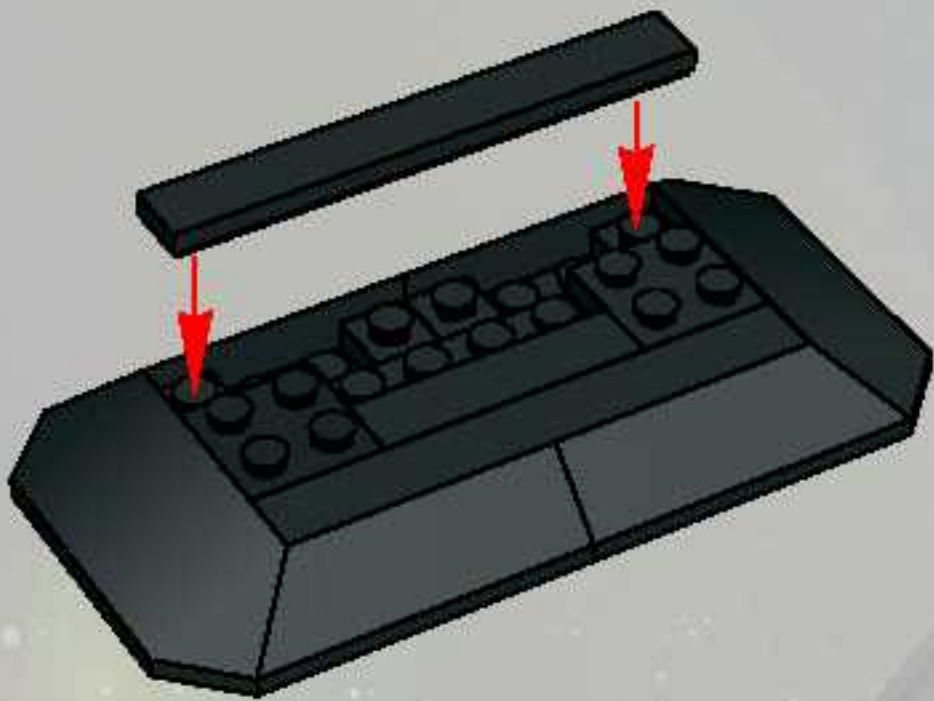

6

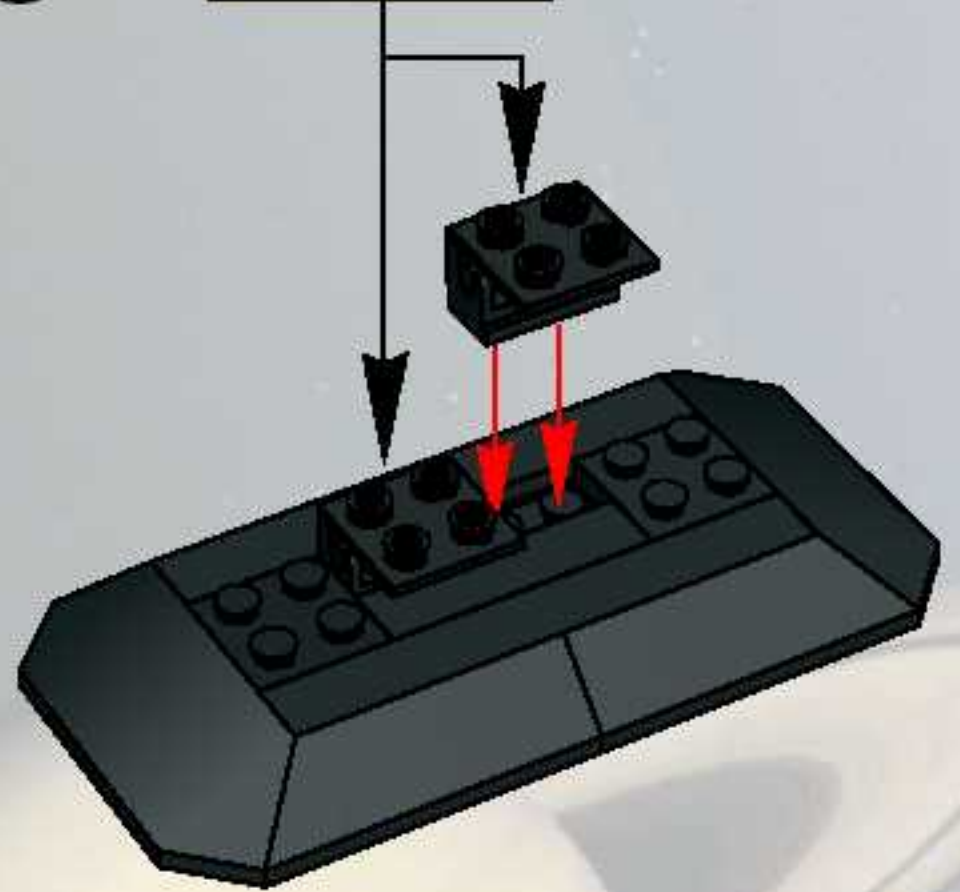
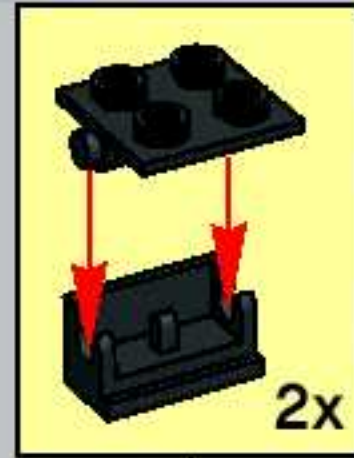



7

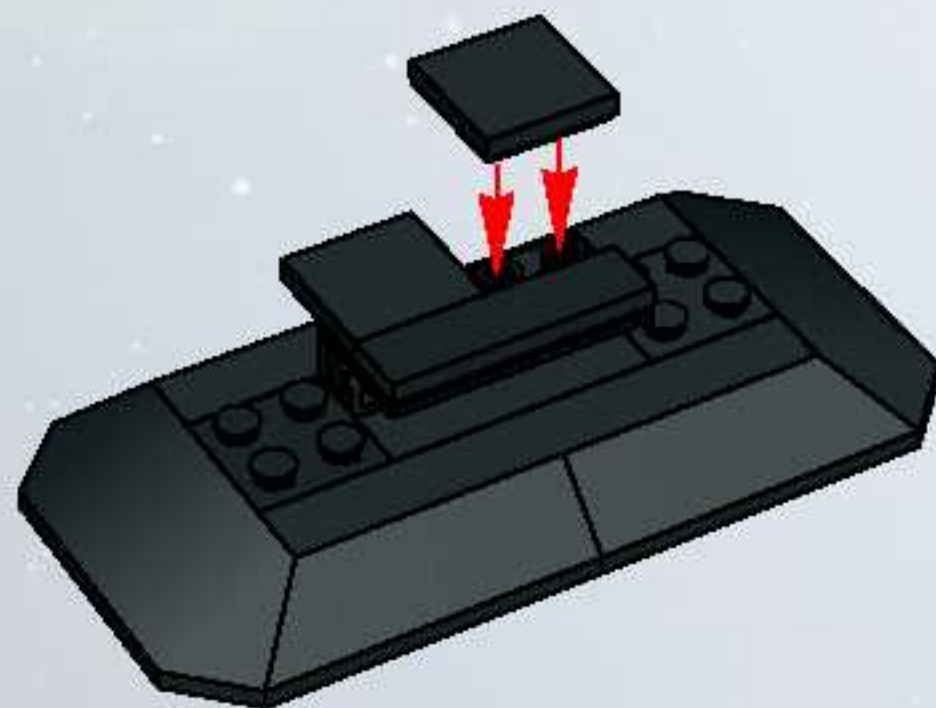

8

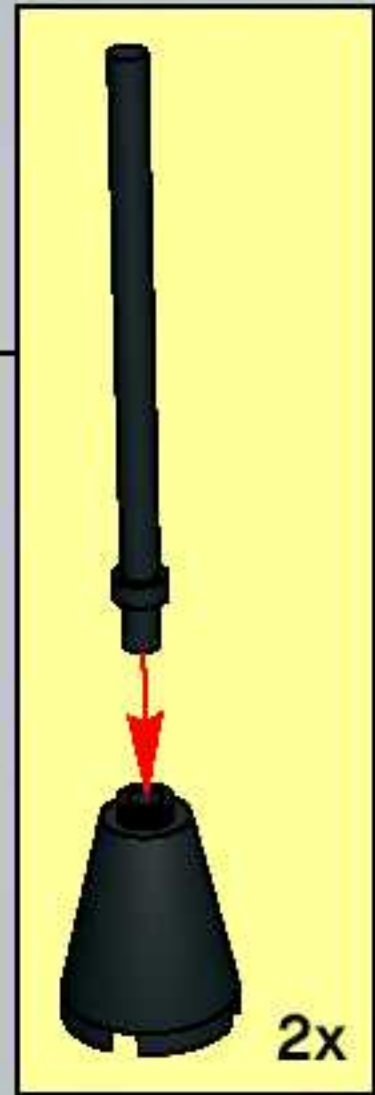



9

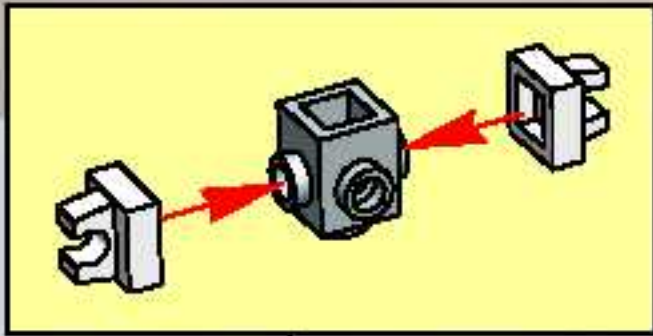

10

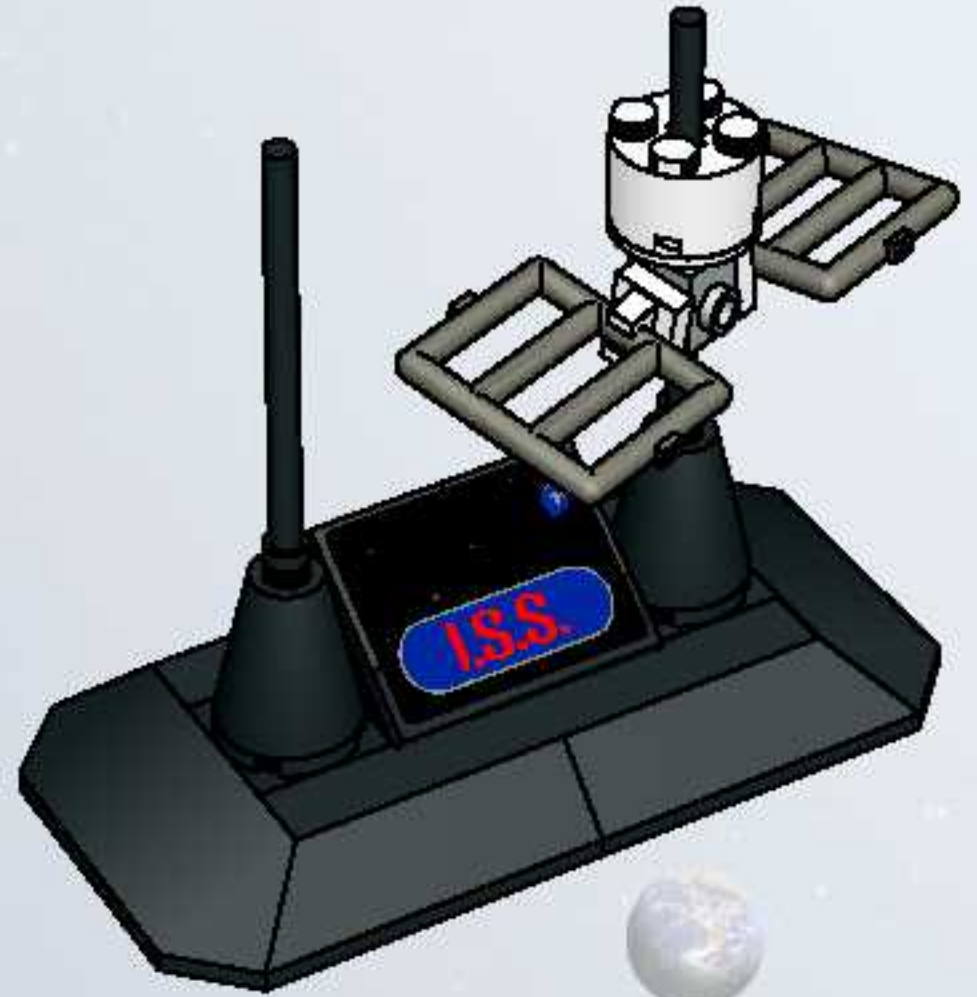

11

1

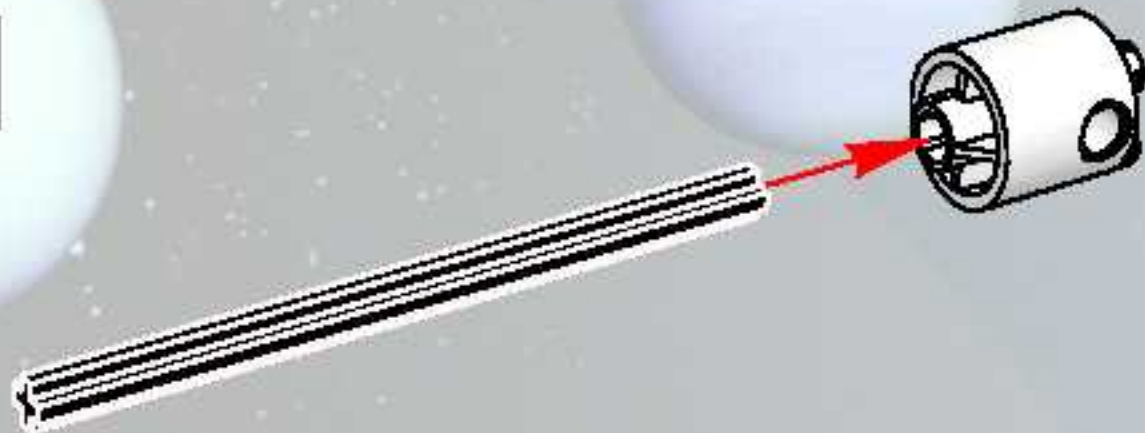

2

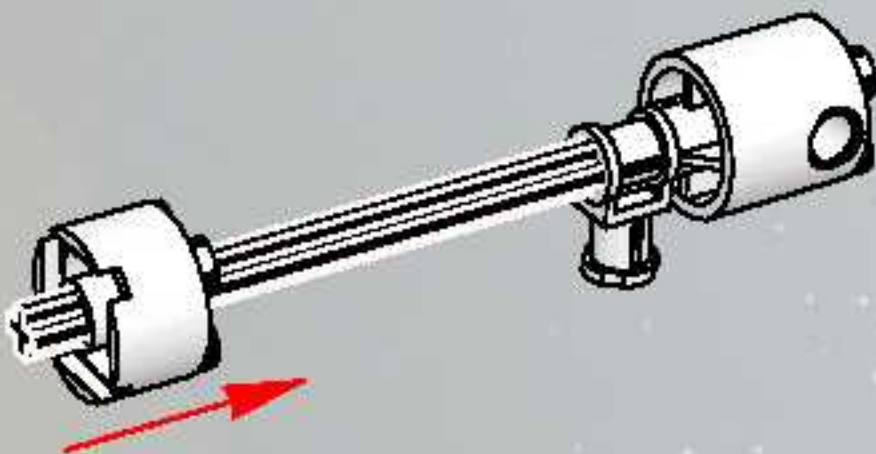

3

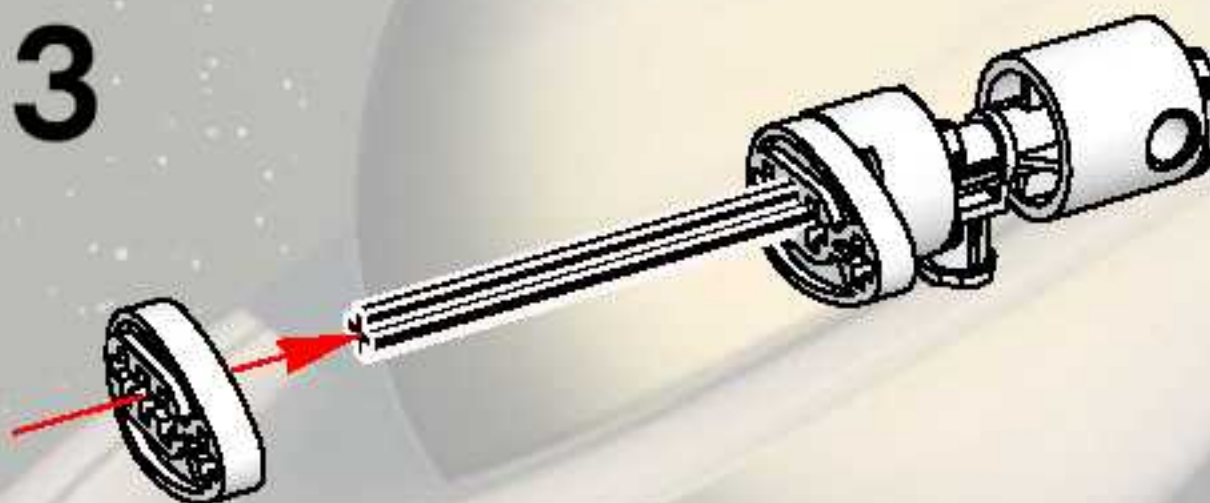



4

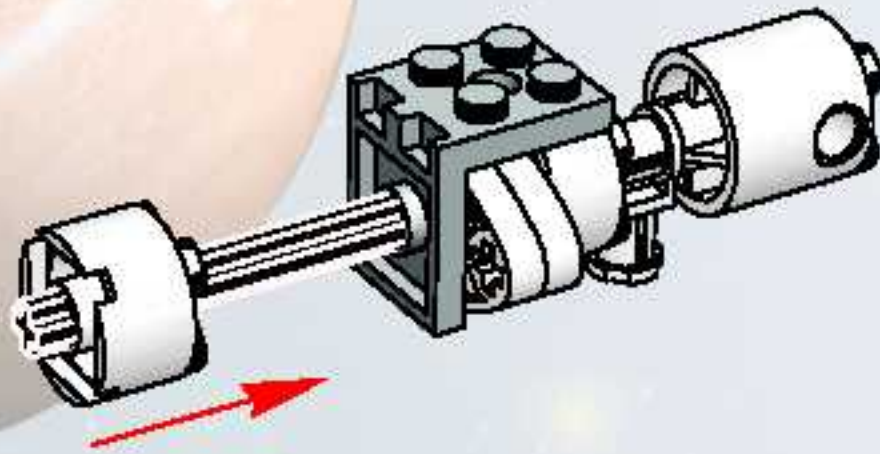

5

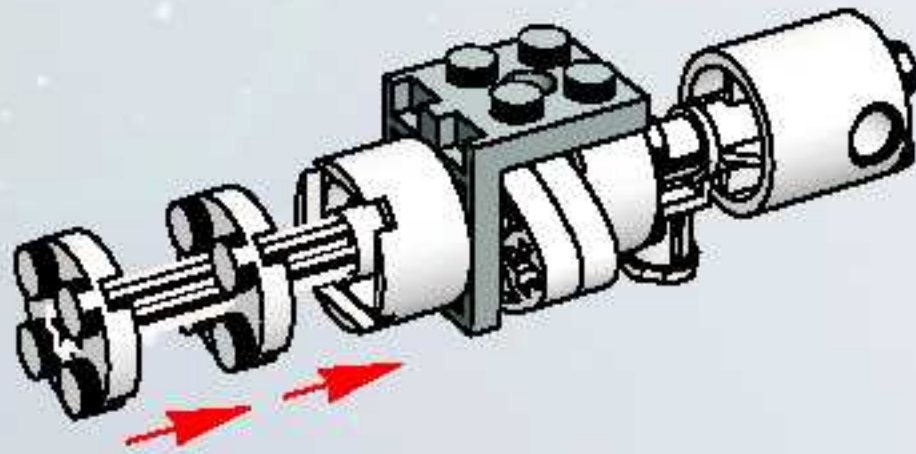

6

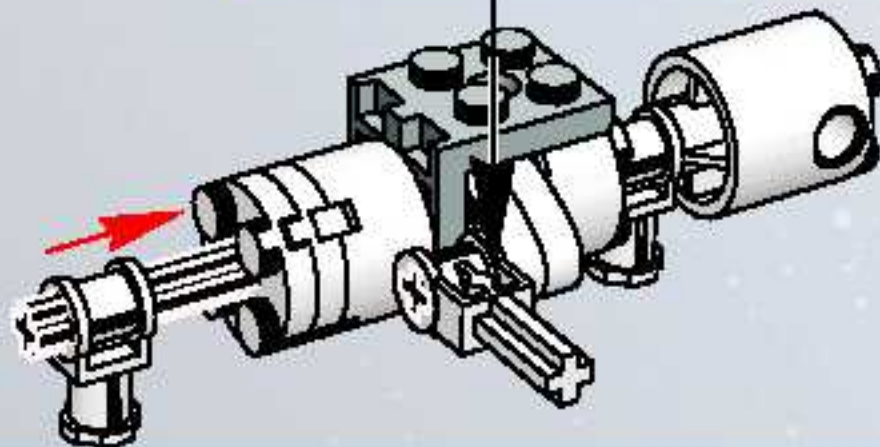
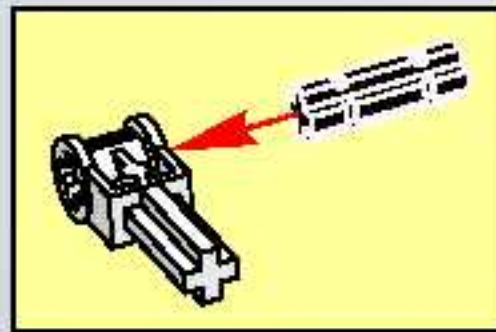

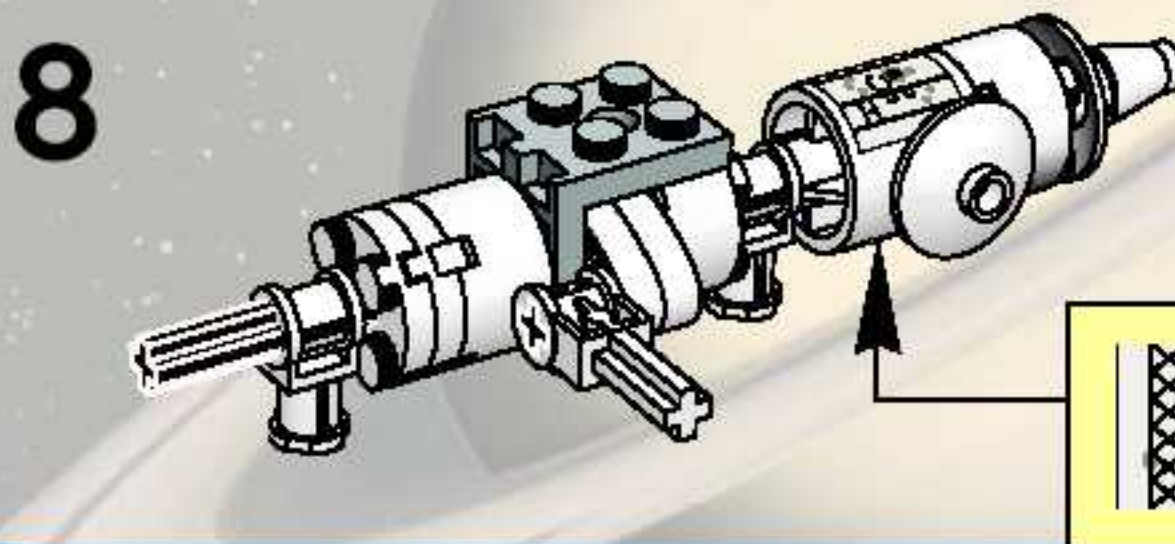
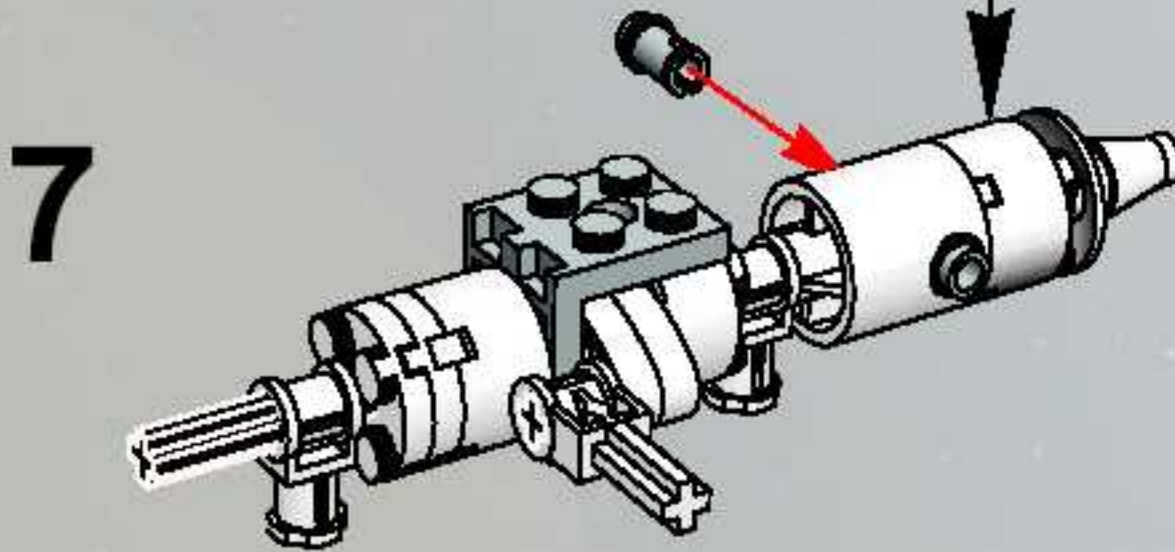
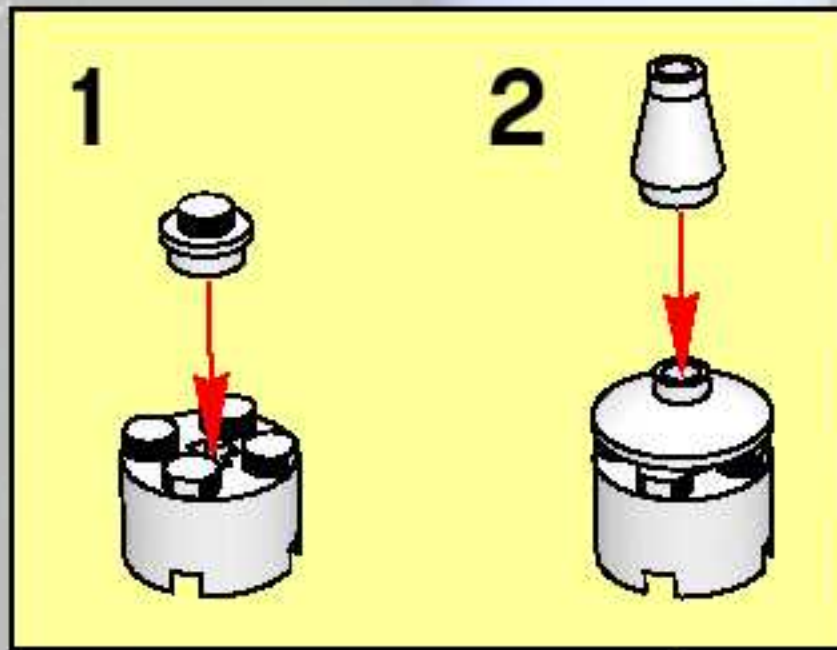



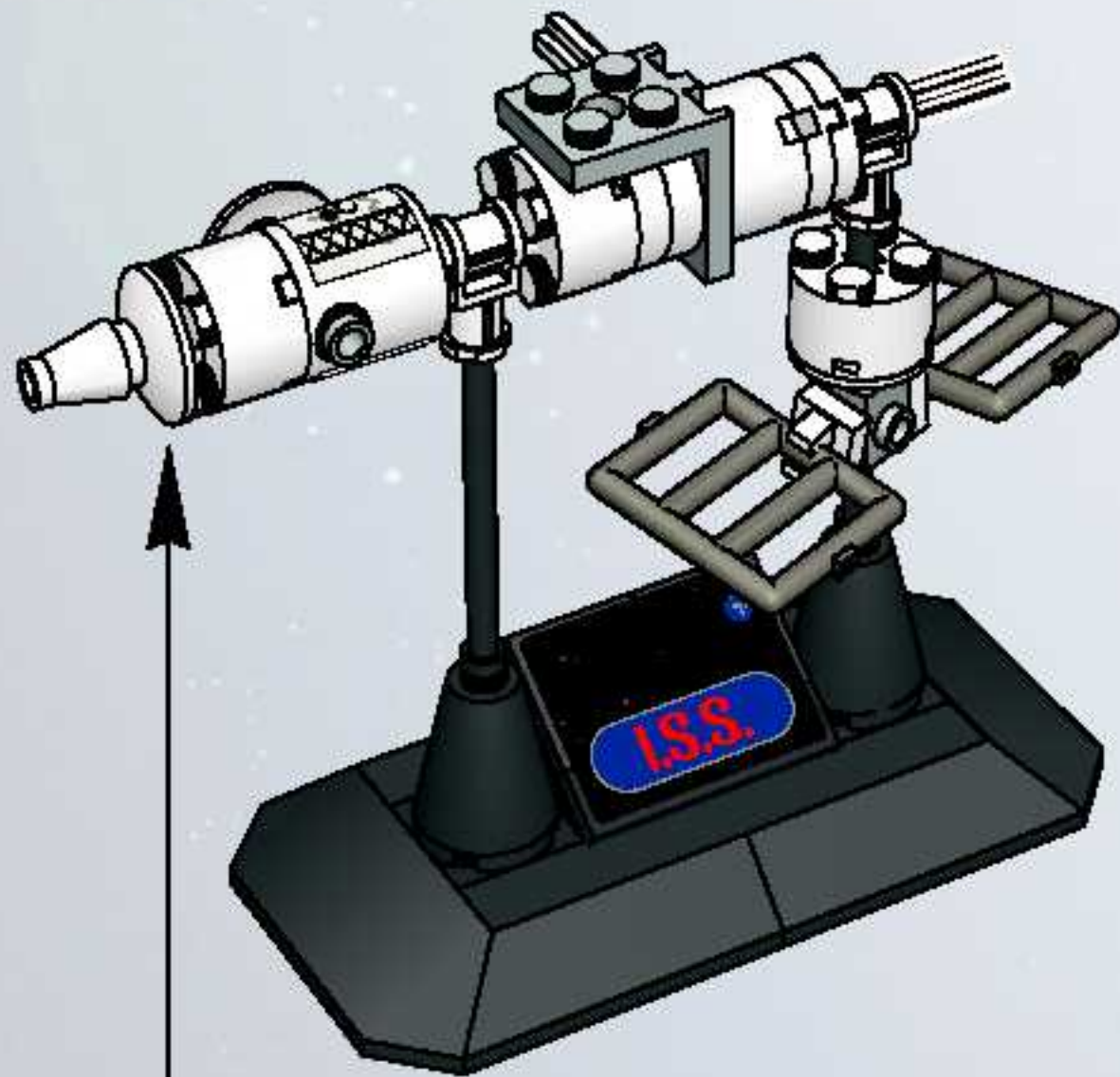

# 12

## 1

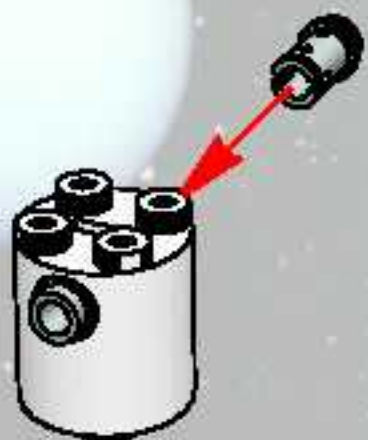

## 2



## 3



## 1



## 2



## 4

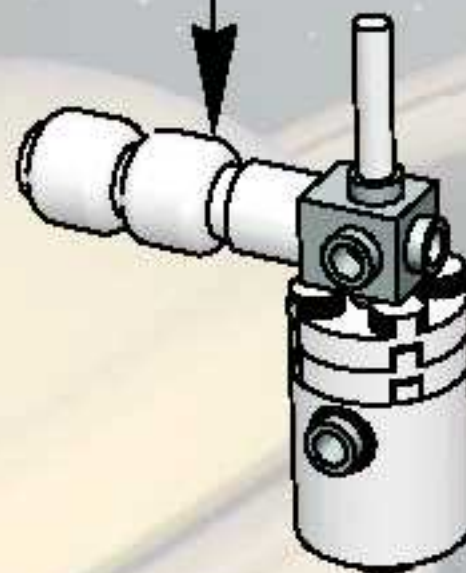



5

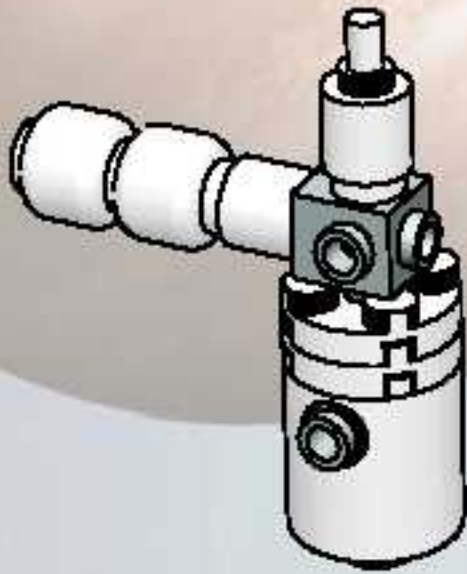

6

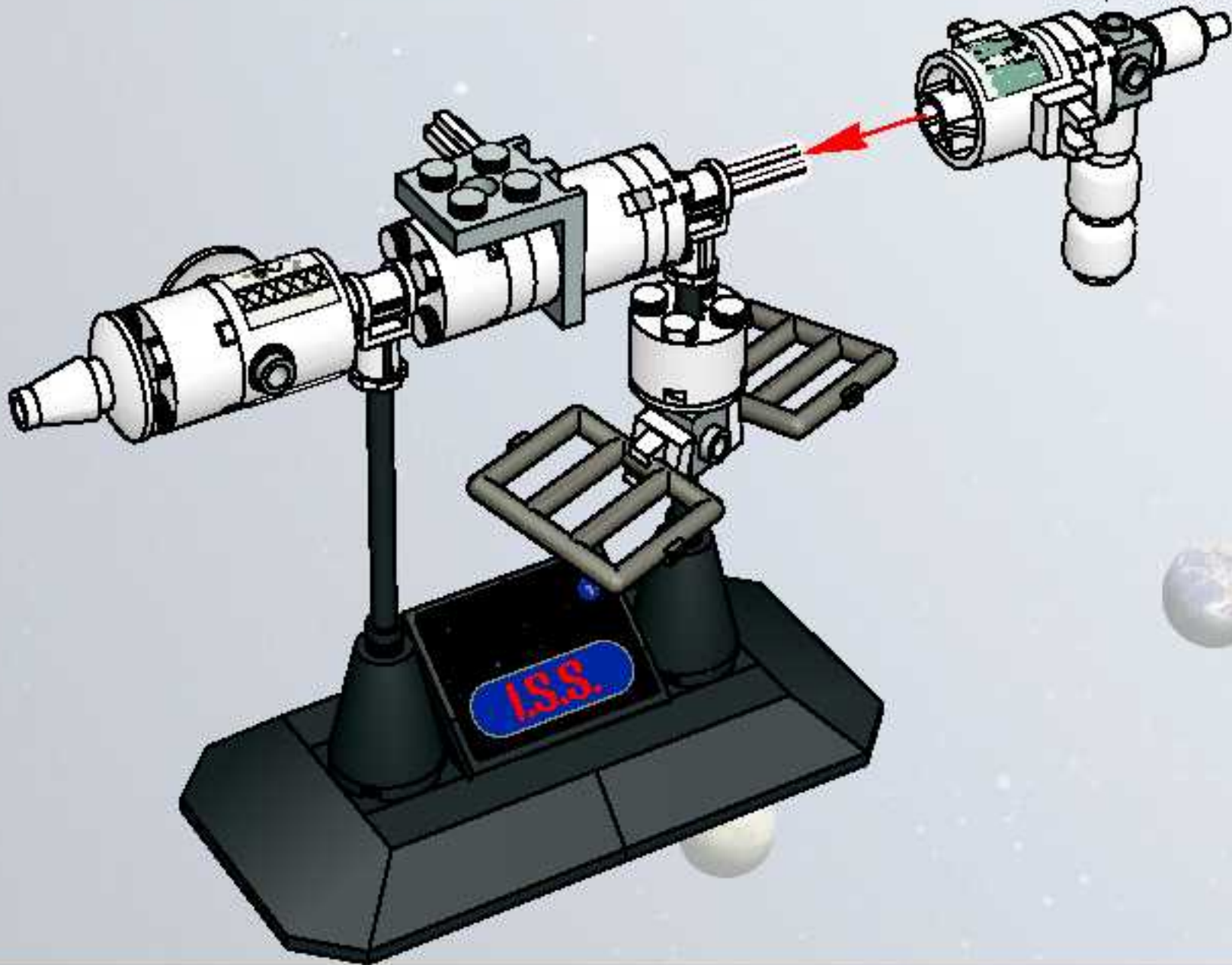
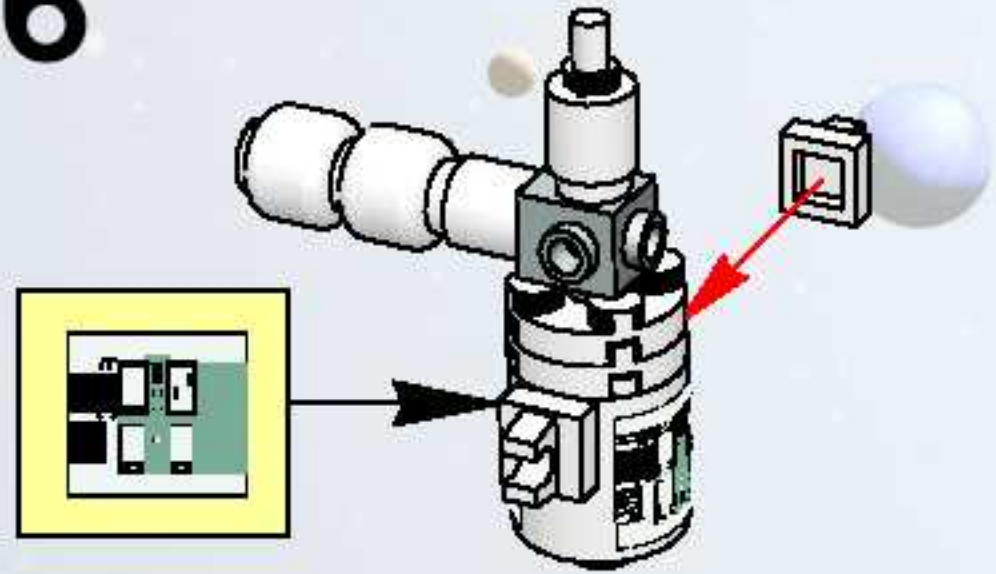

13

1

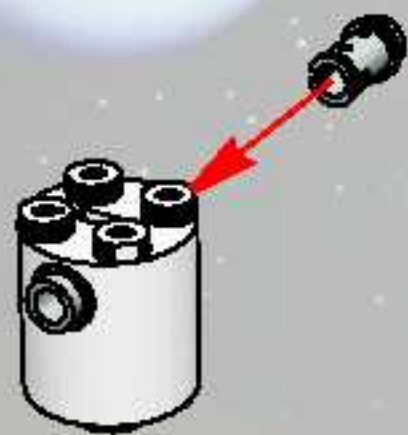

2



3

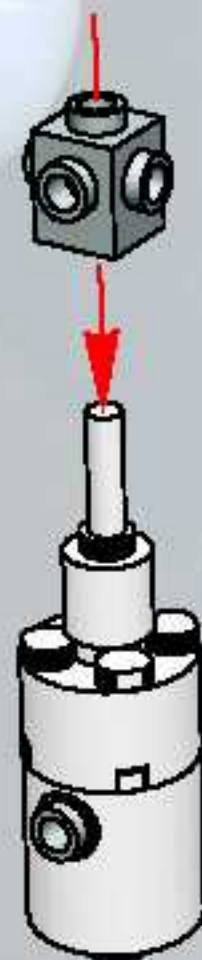

4

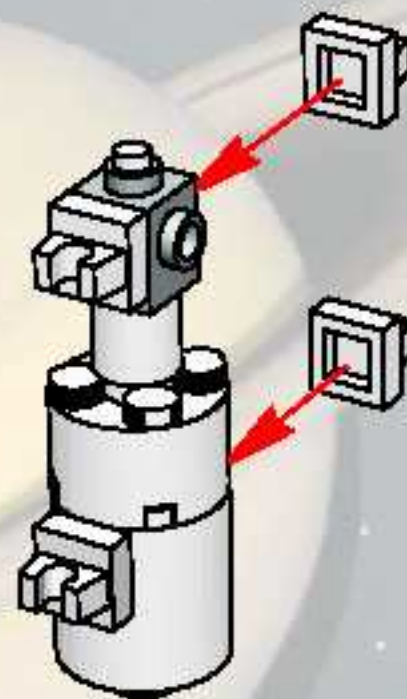



5



6

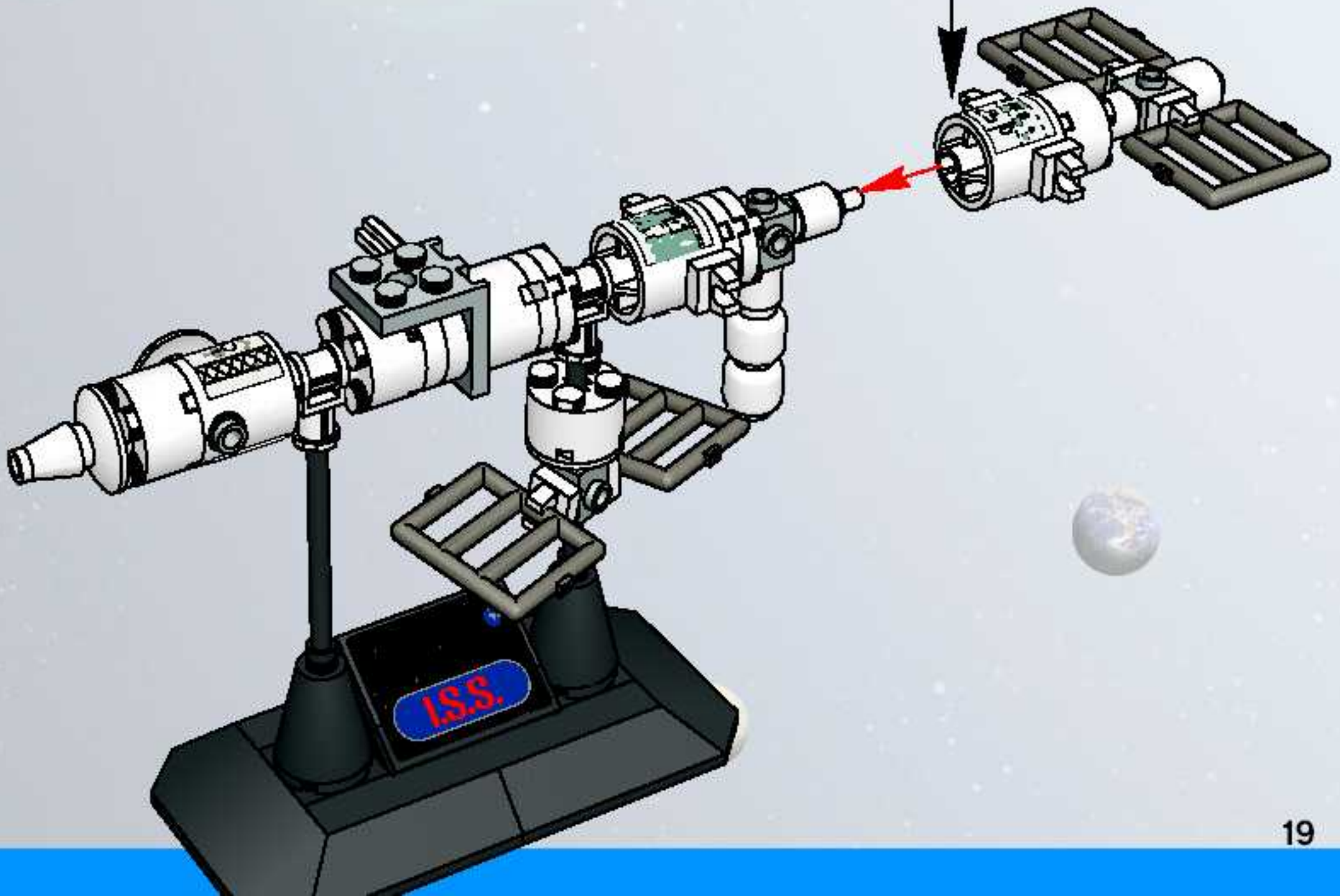
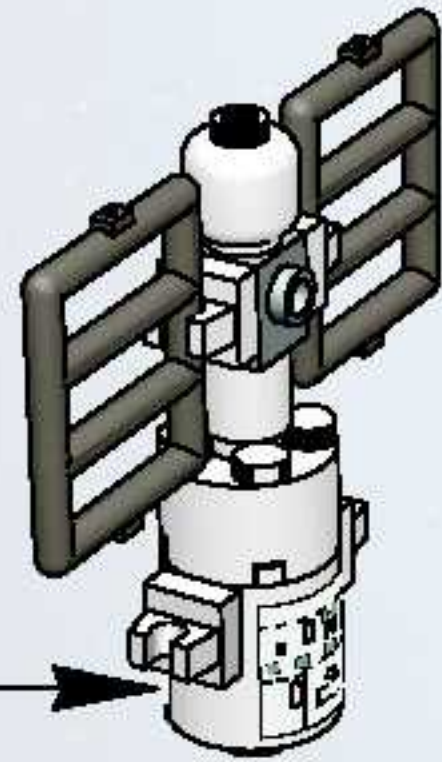
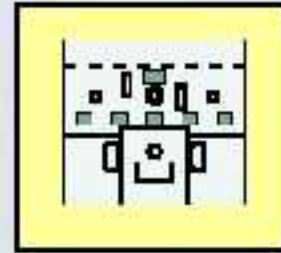



14

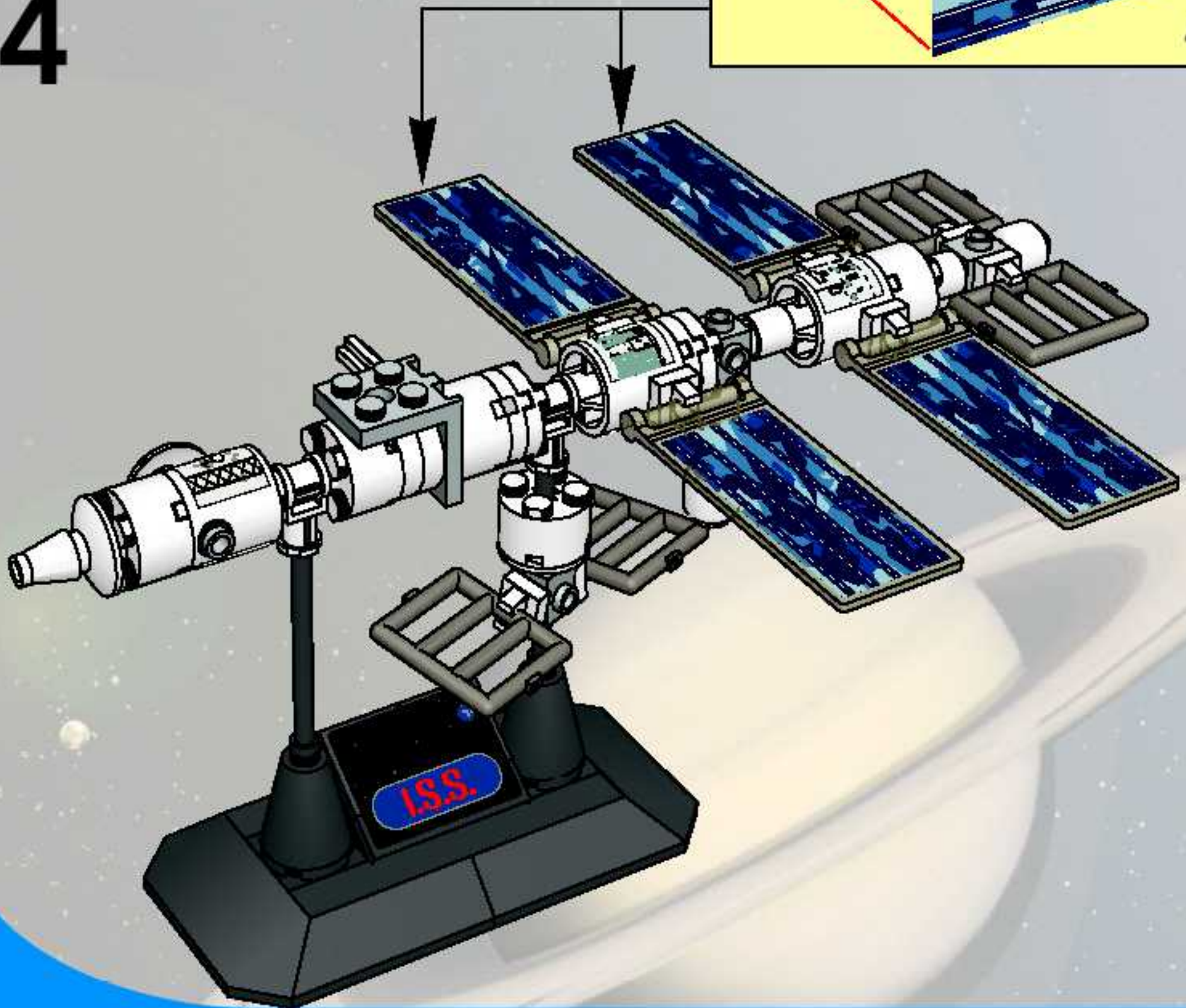
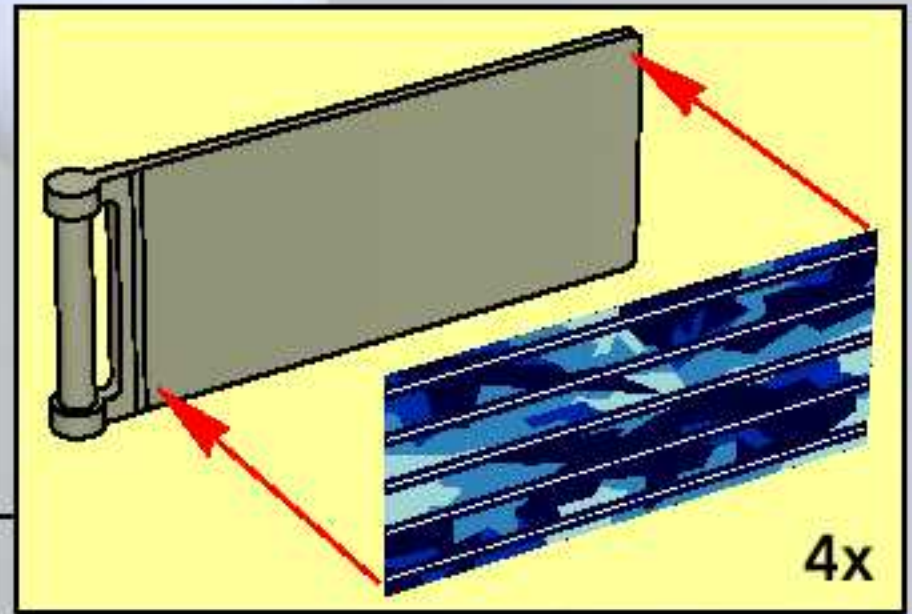



15

1



2

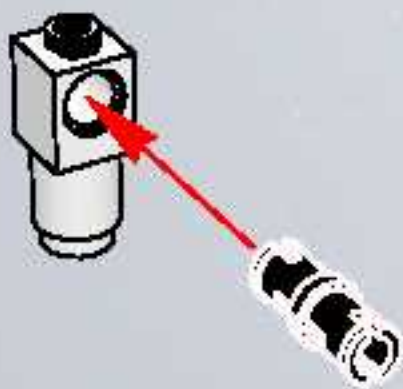

3

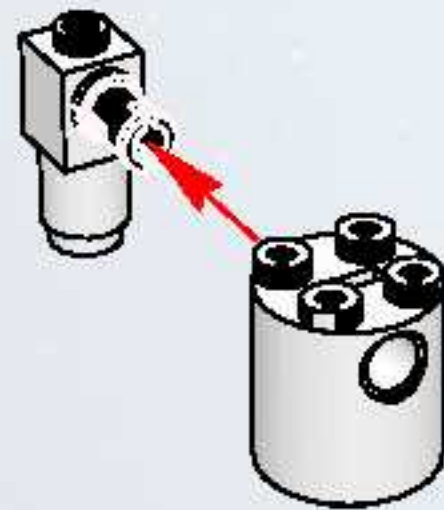

4

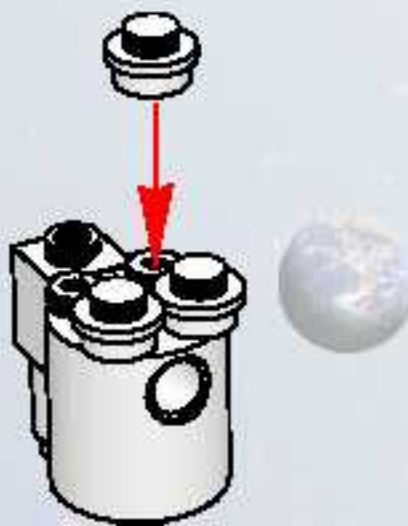

5



6

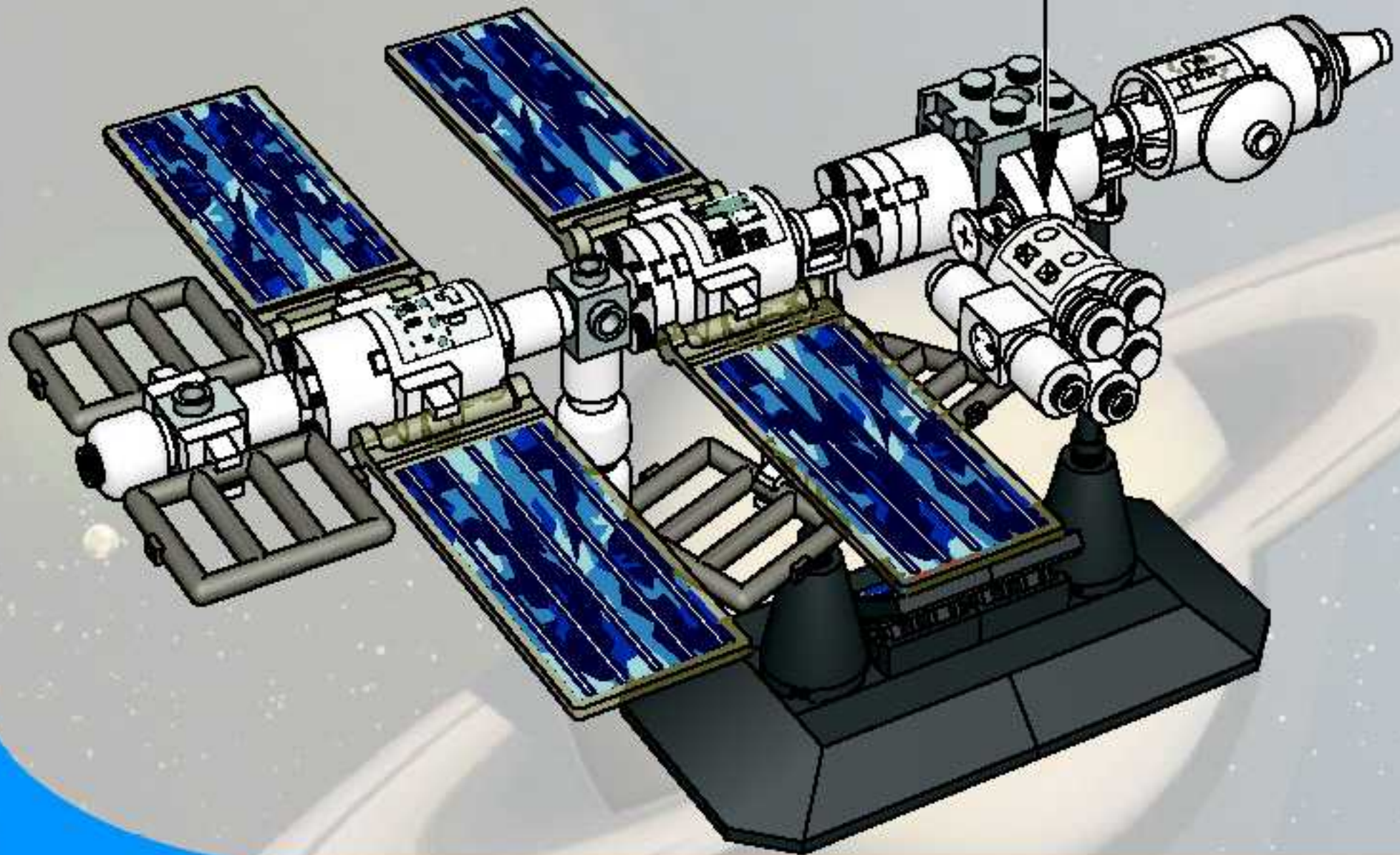
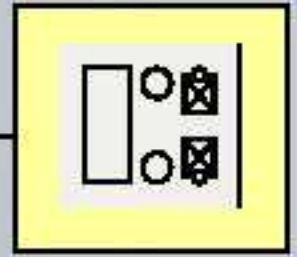
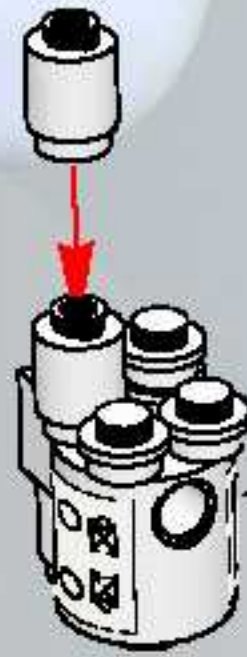



# 16

## 1

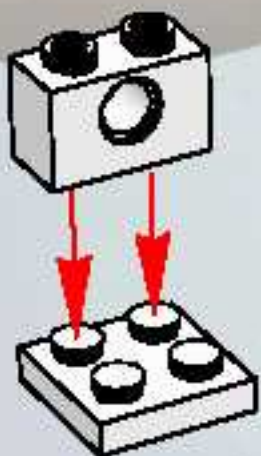

## 2

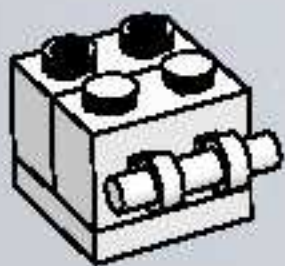

## 3

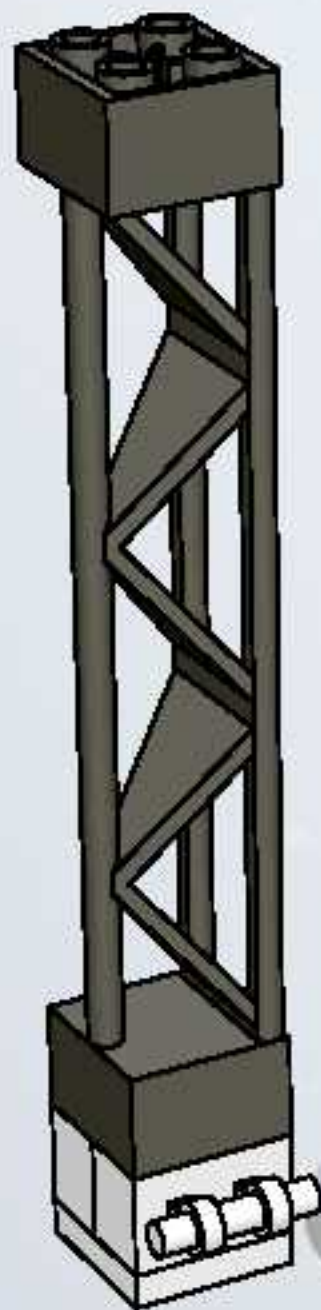

4

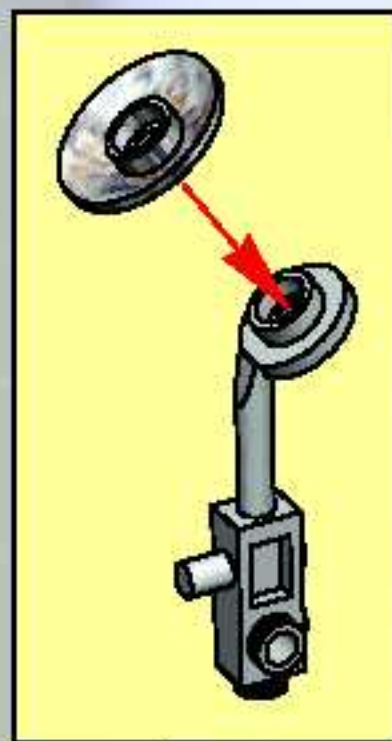
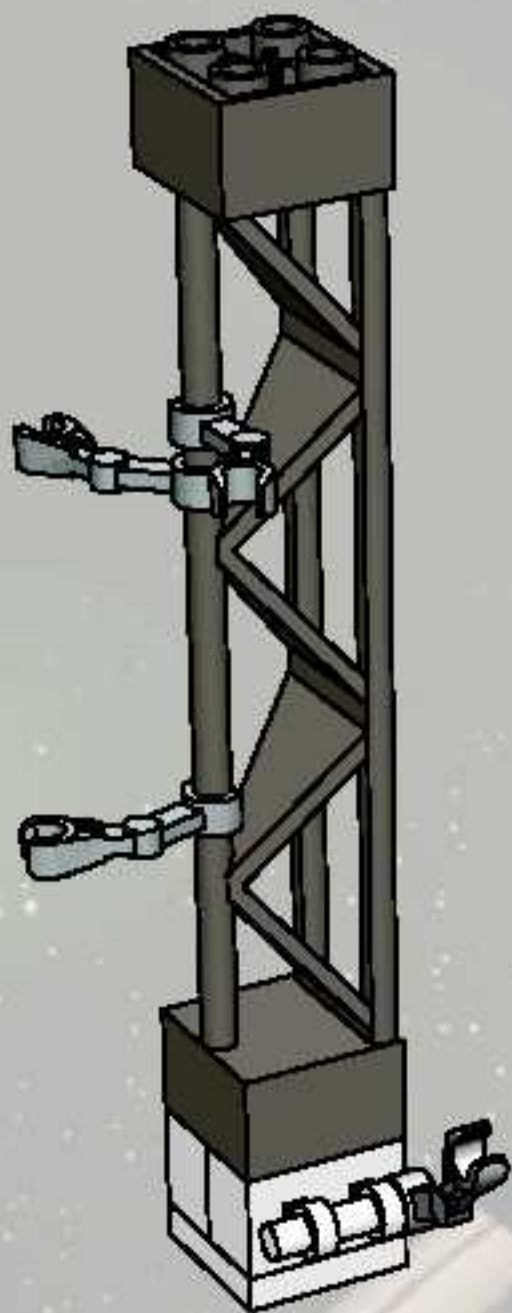

5

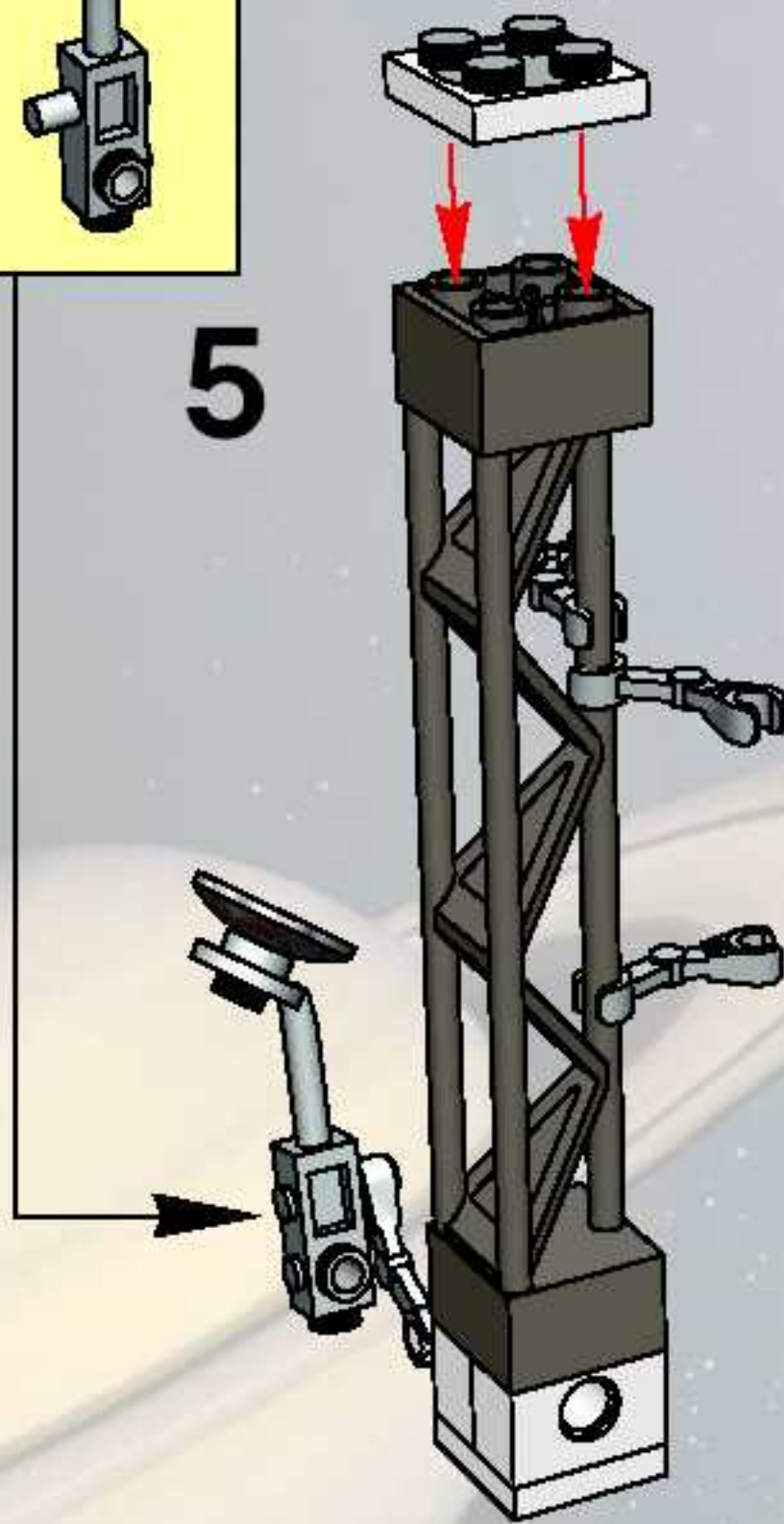



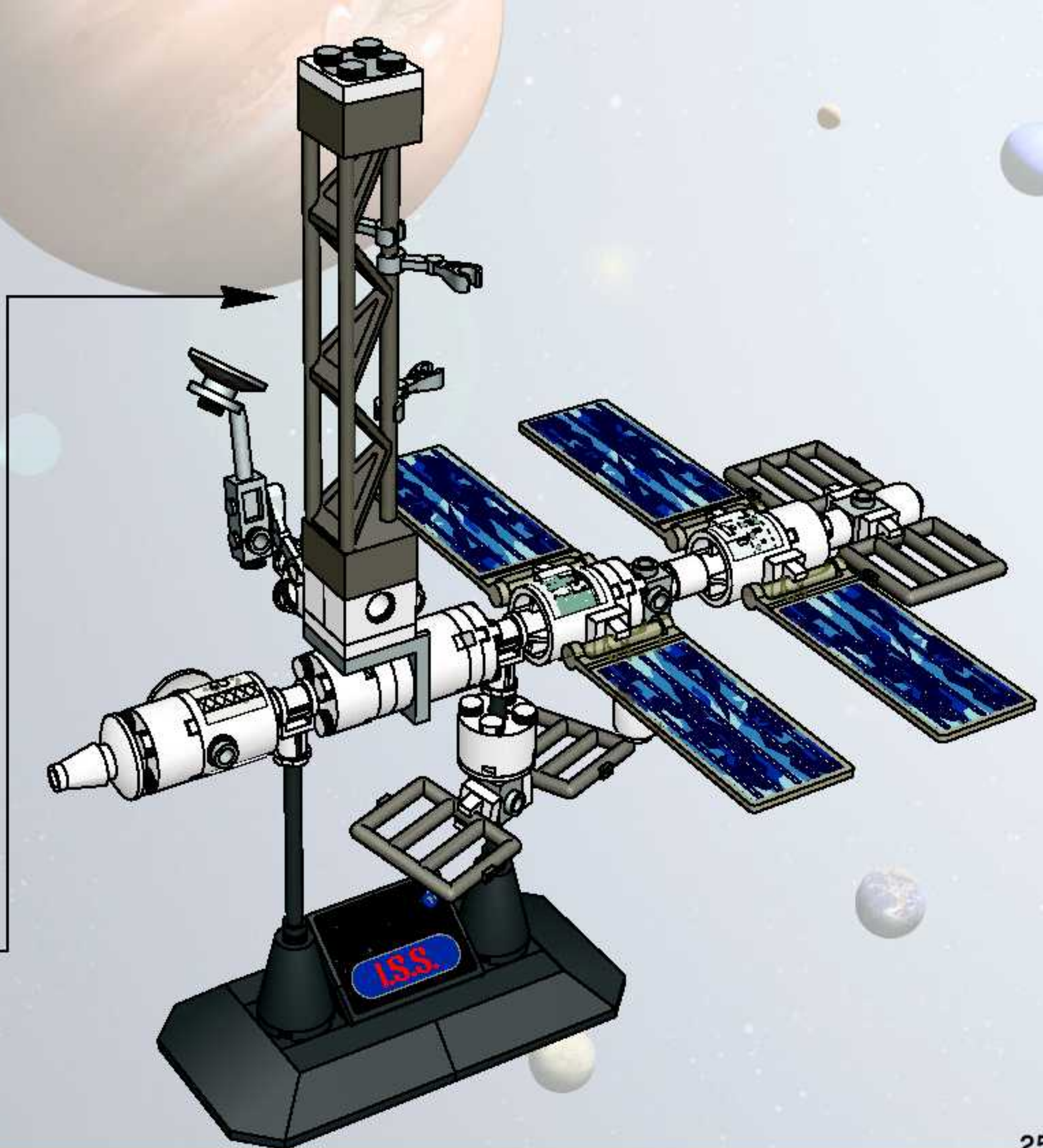



17

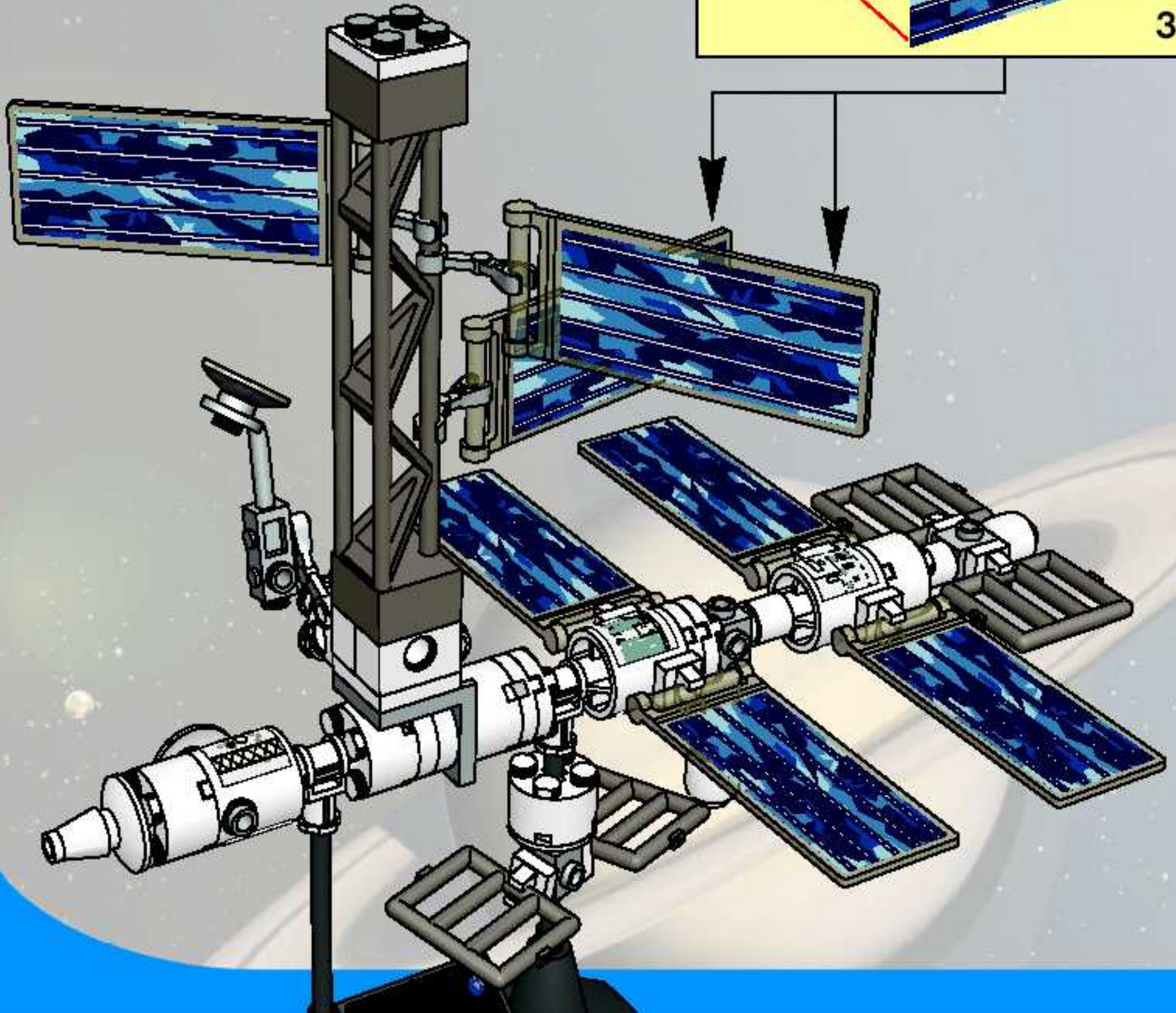
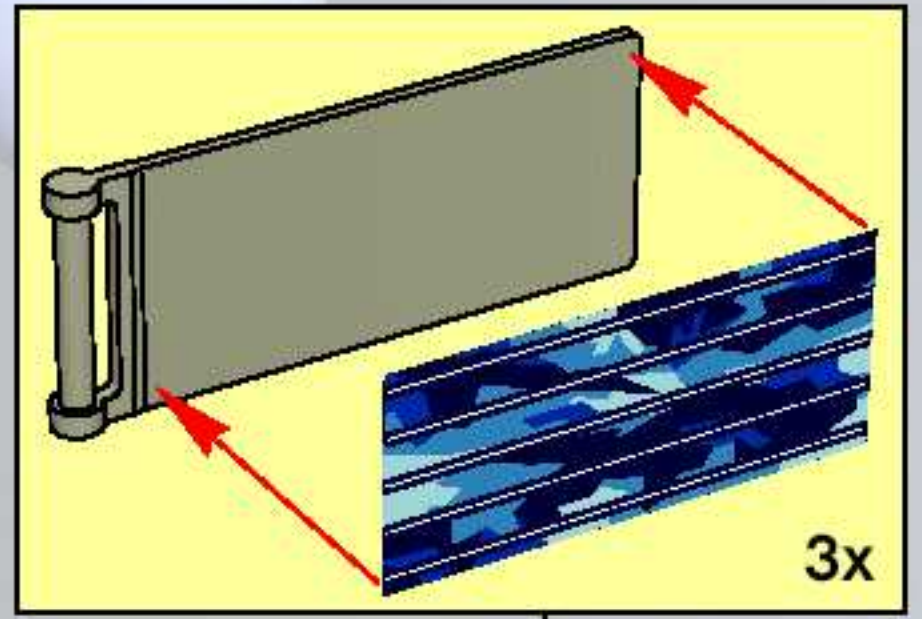



1



2

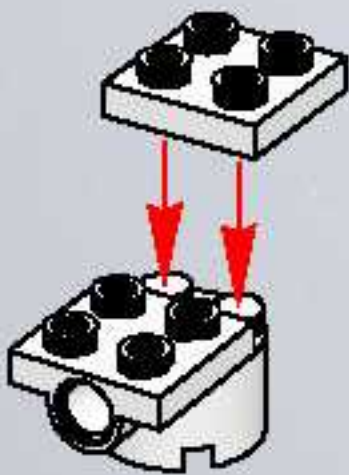

3

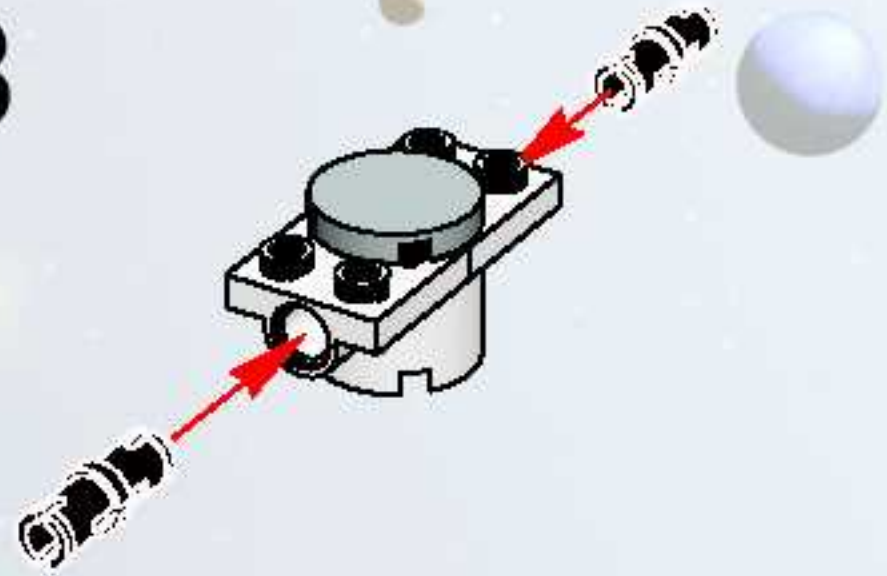

4

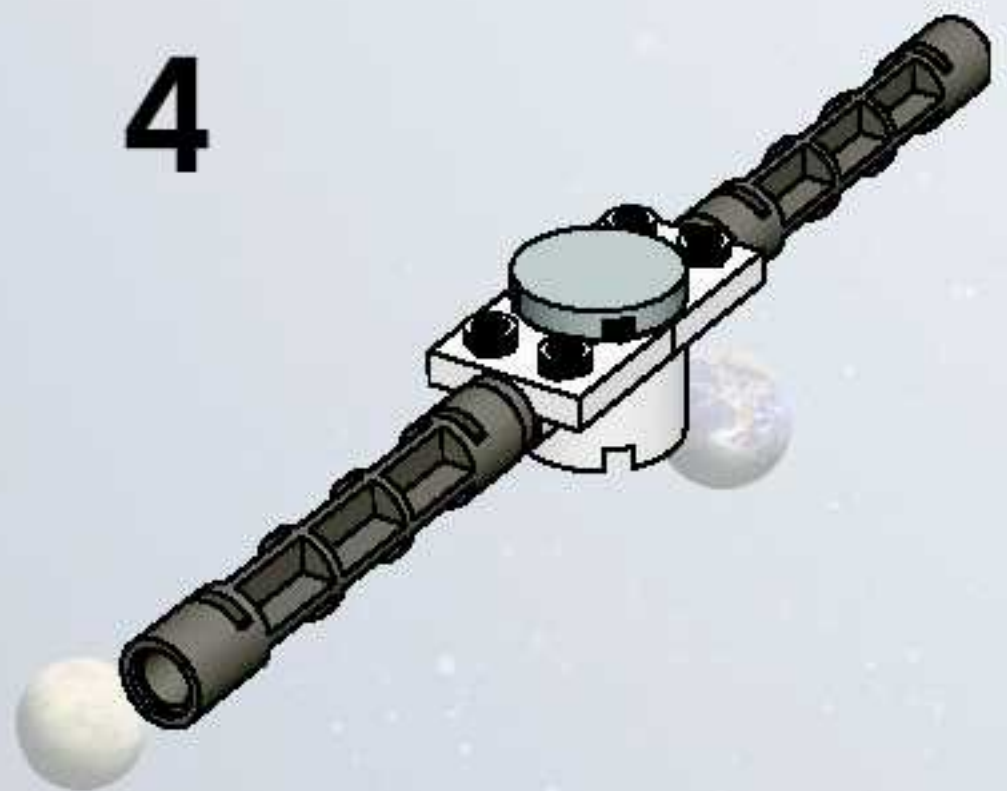

5

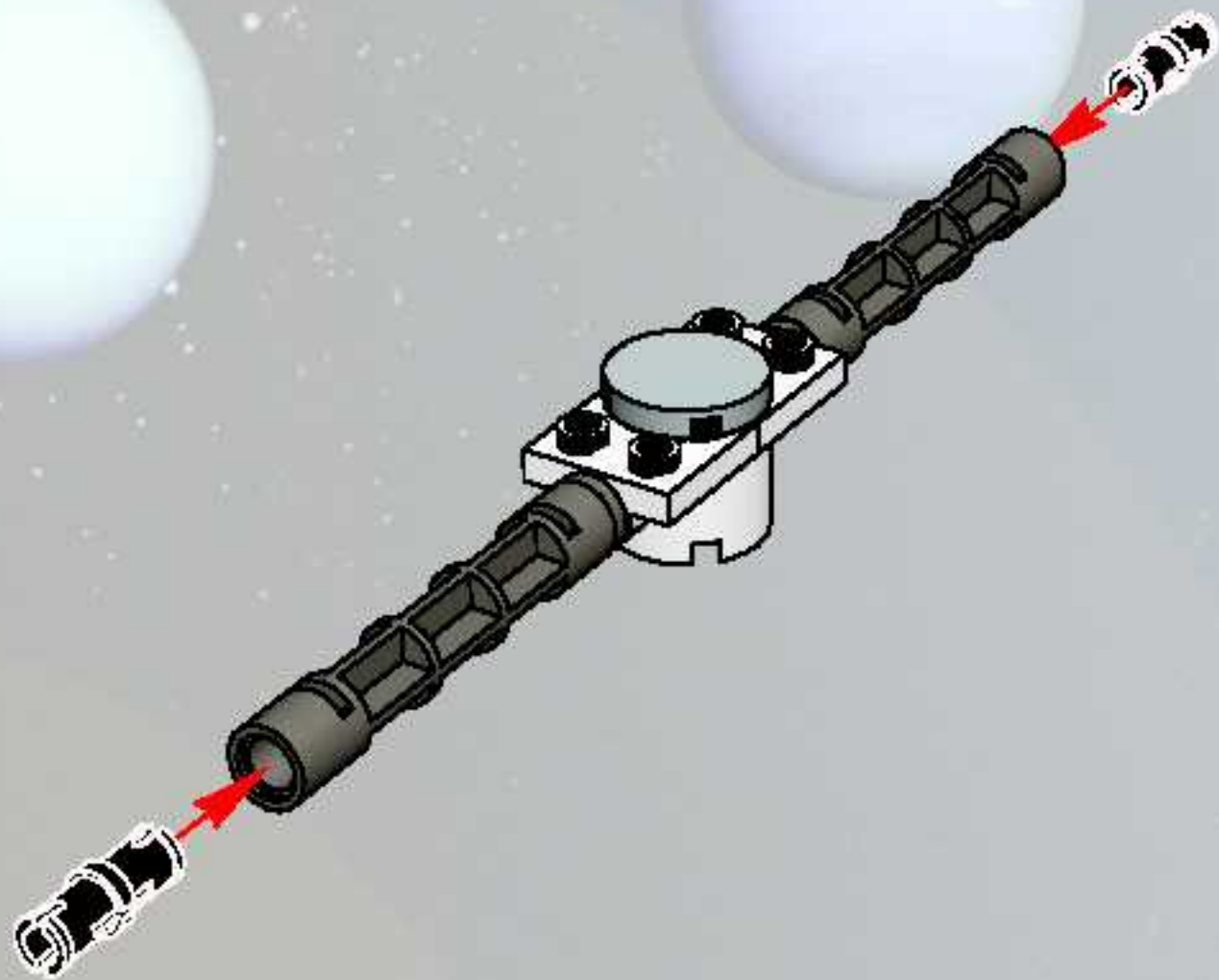

6

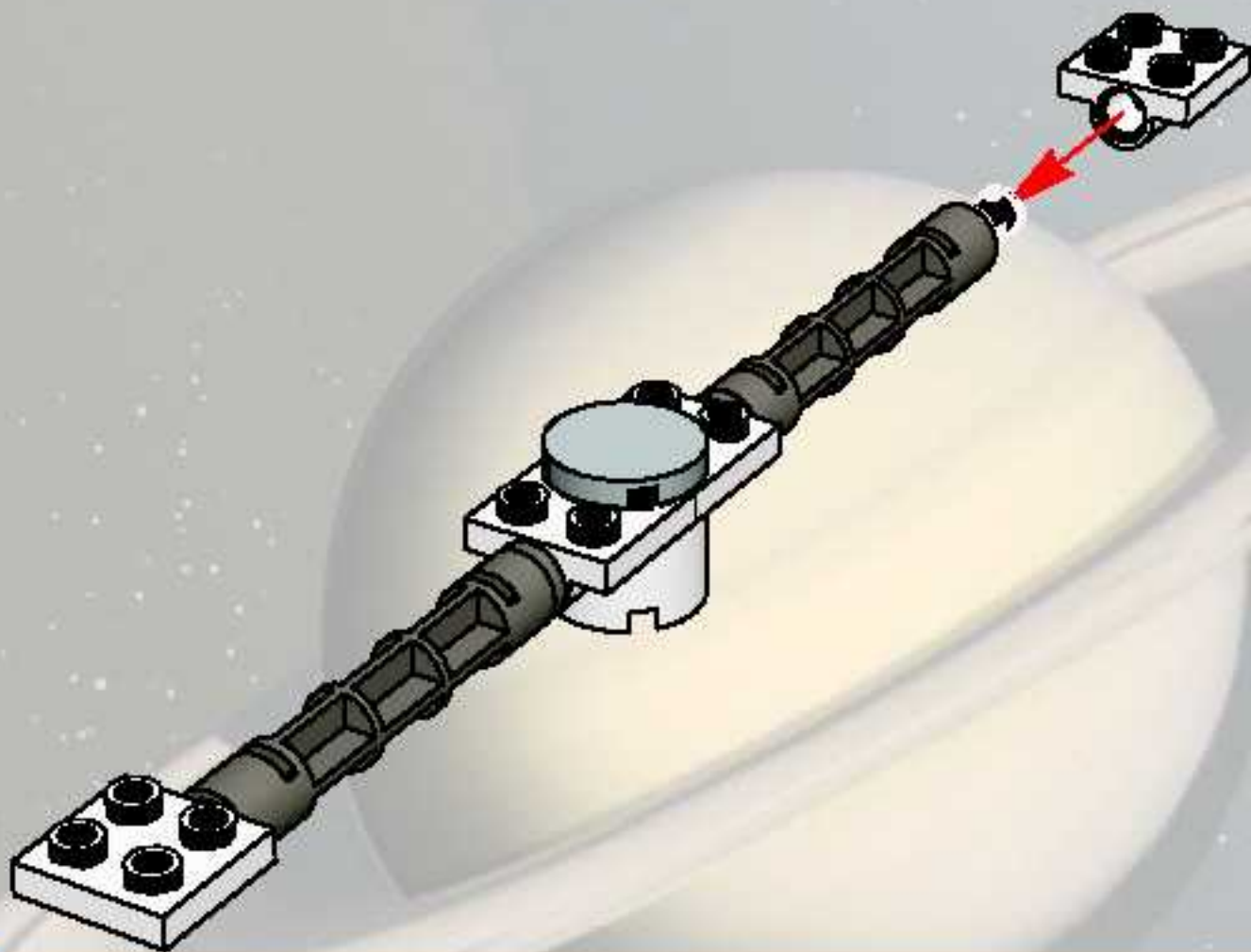



7

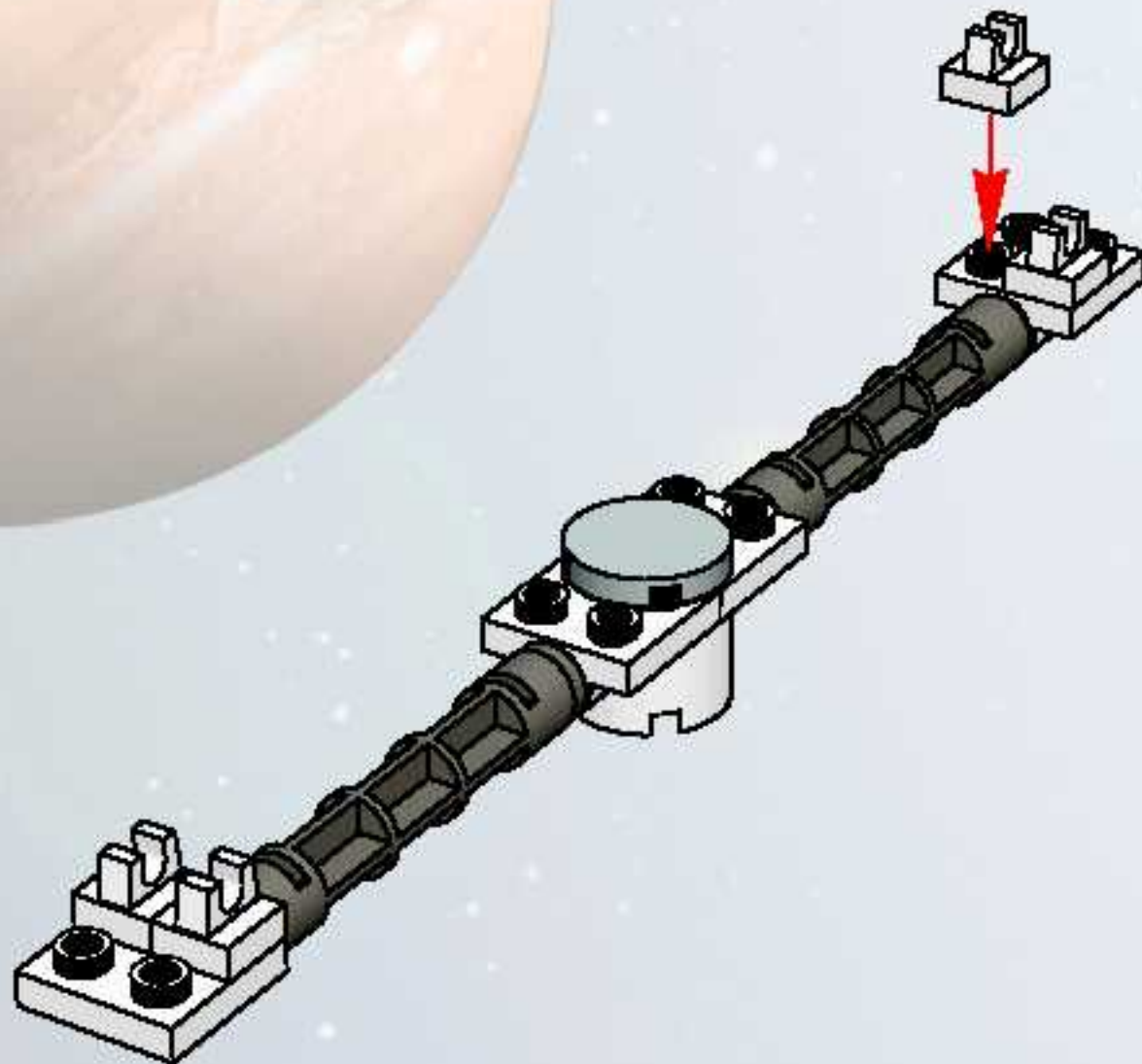

8

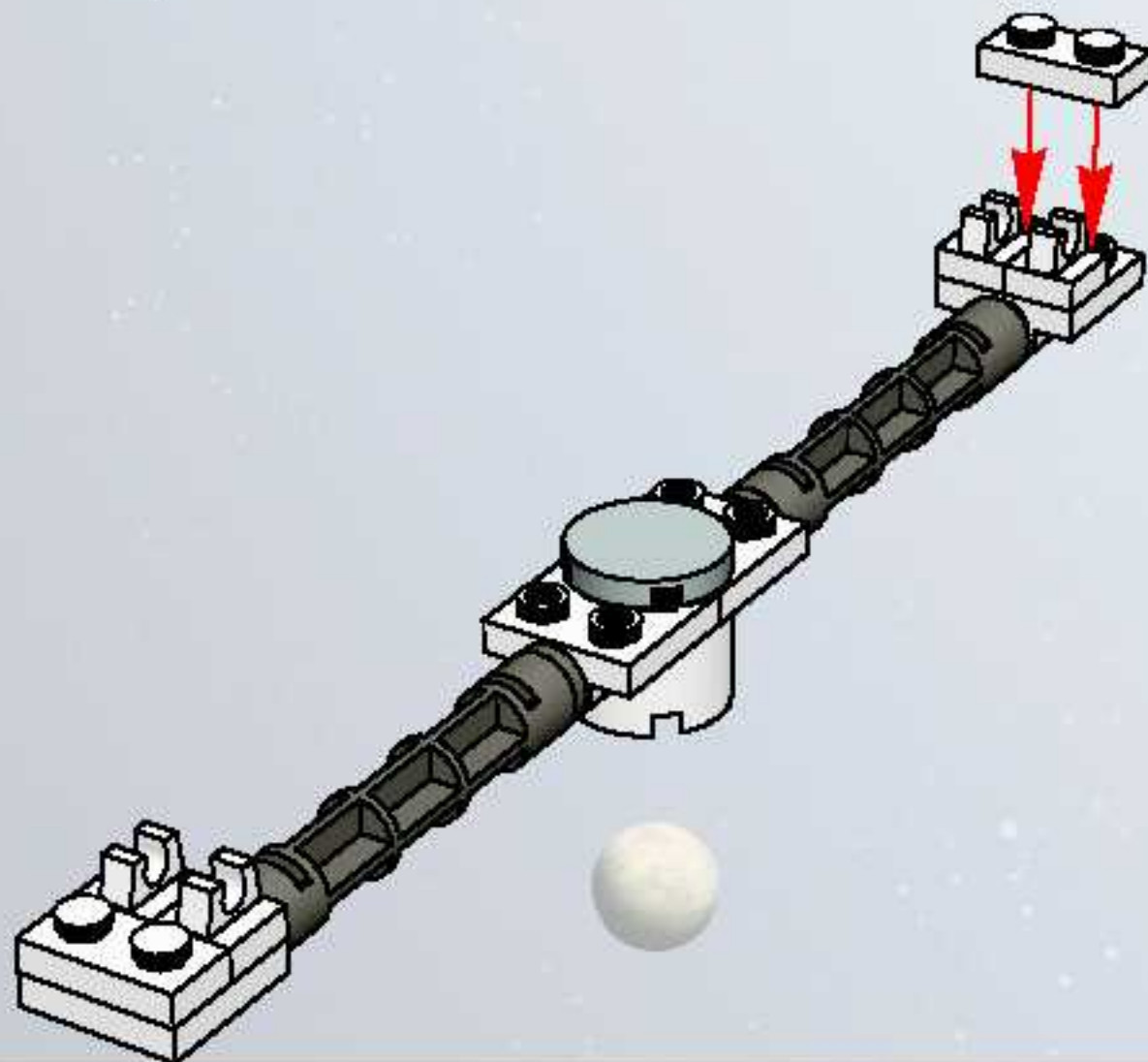

9

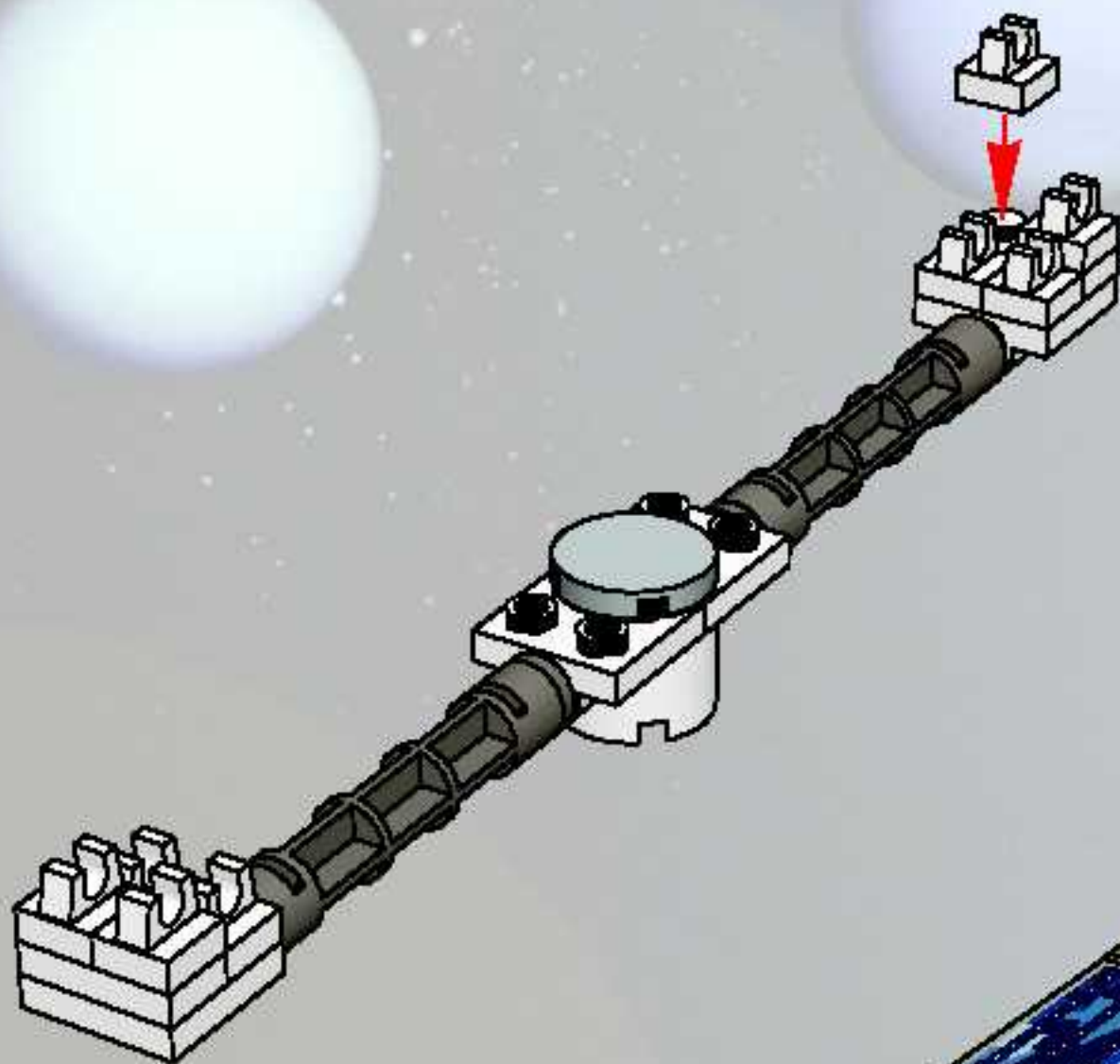

10

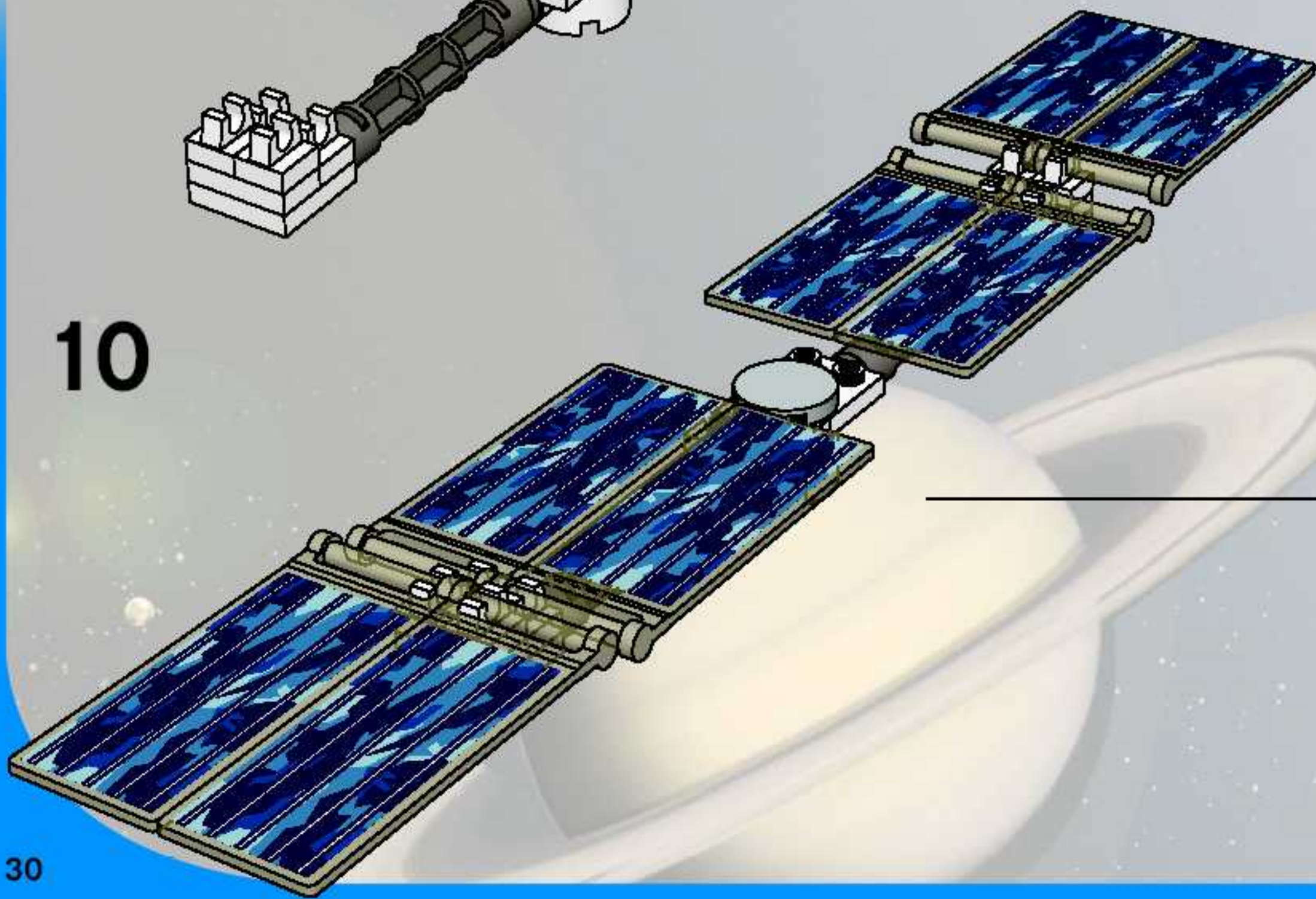



18

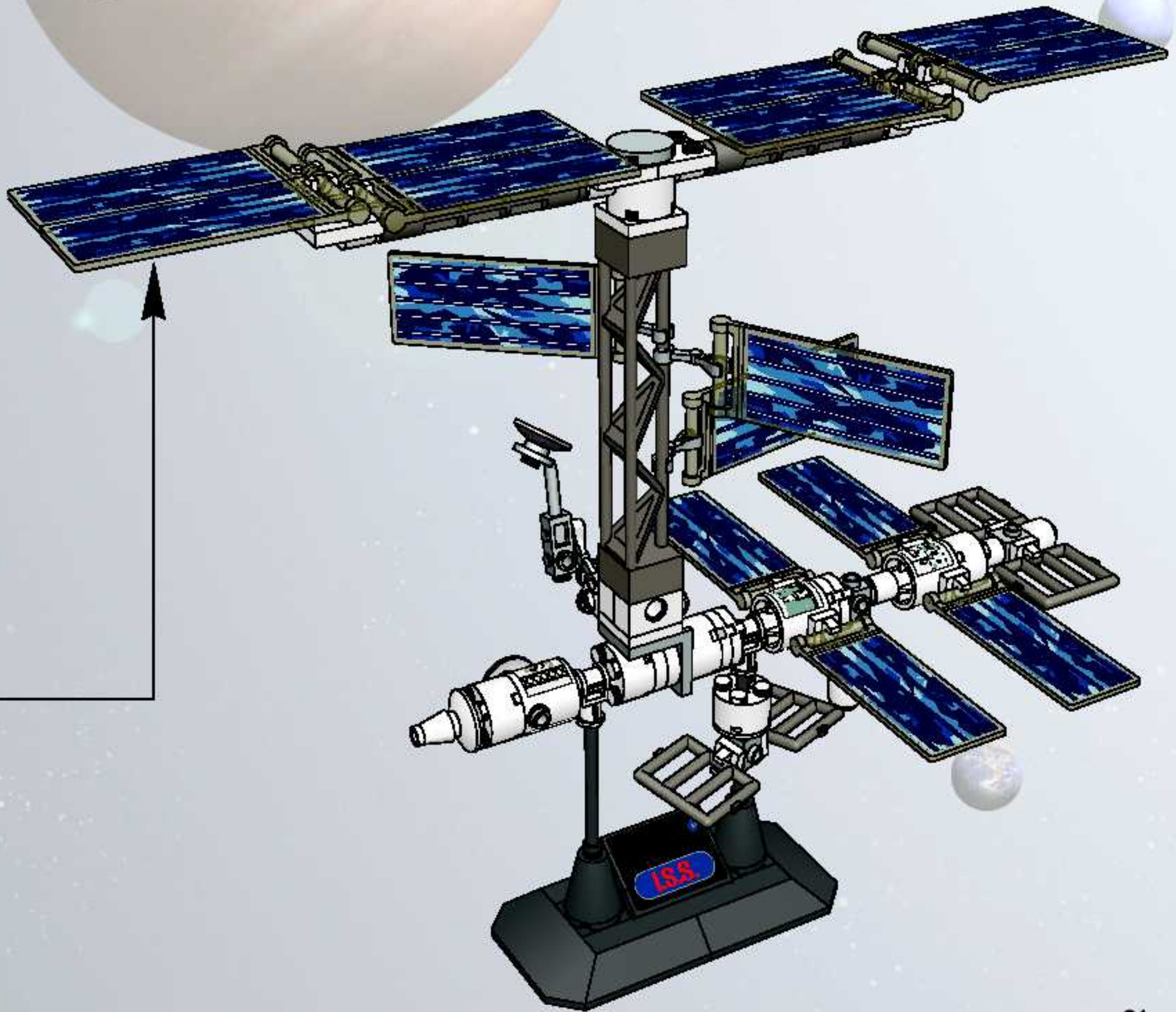



19

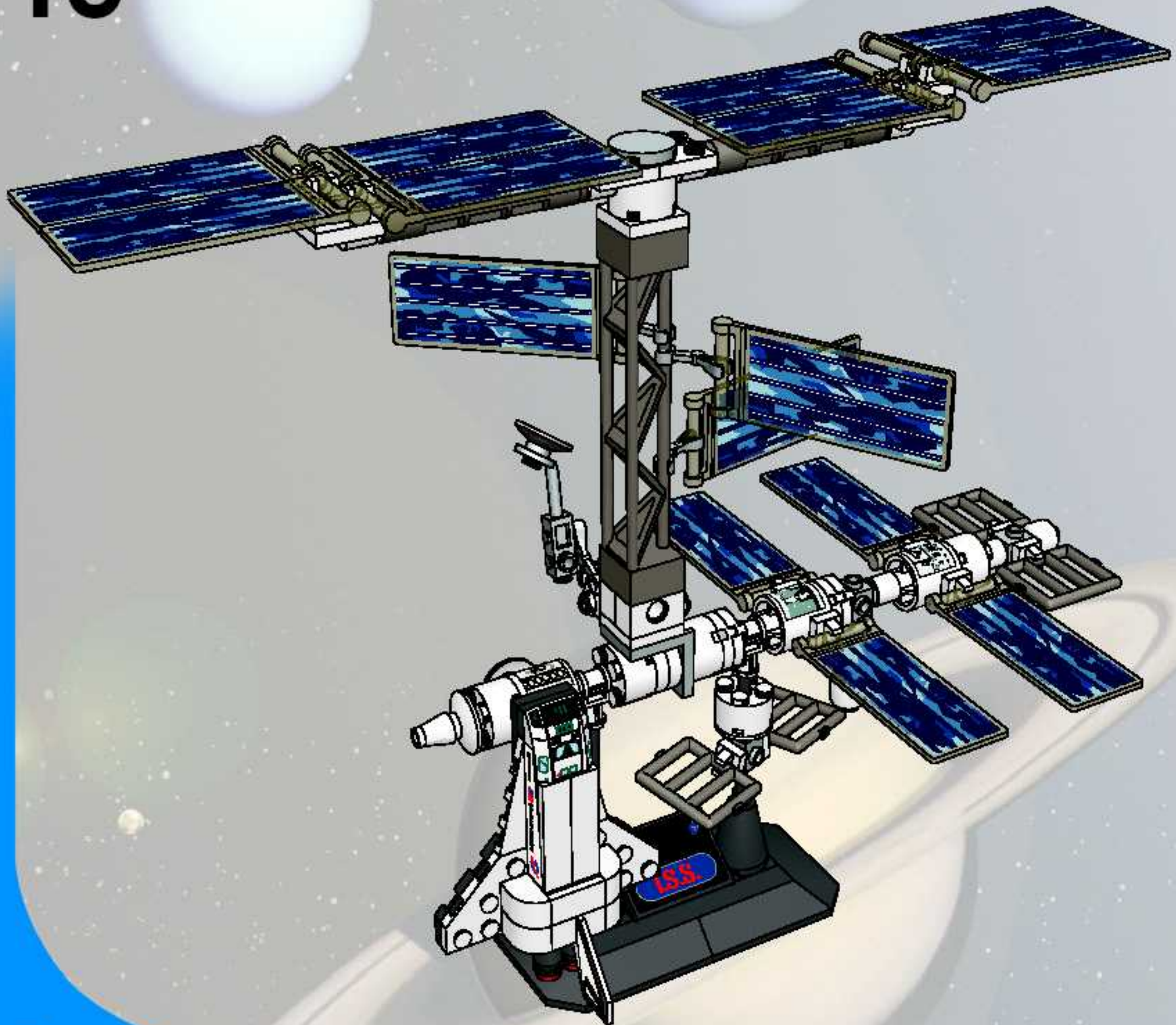



7467 INTERNATIONAL SPACE STATION

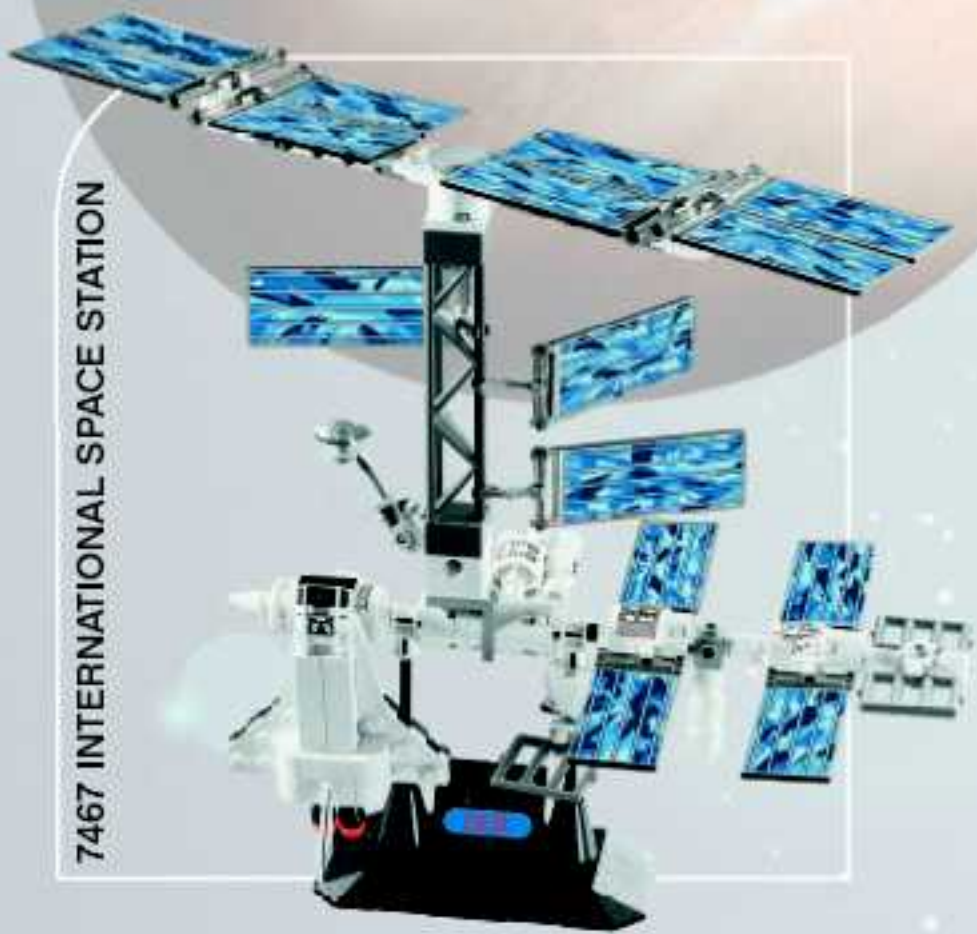

7469 MISSION TO MARS



7471 MARS EXPLORATION ROVER

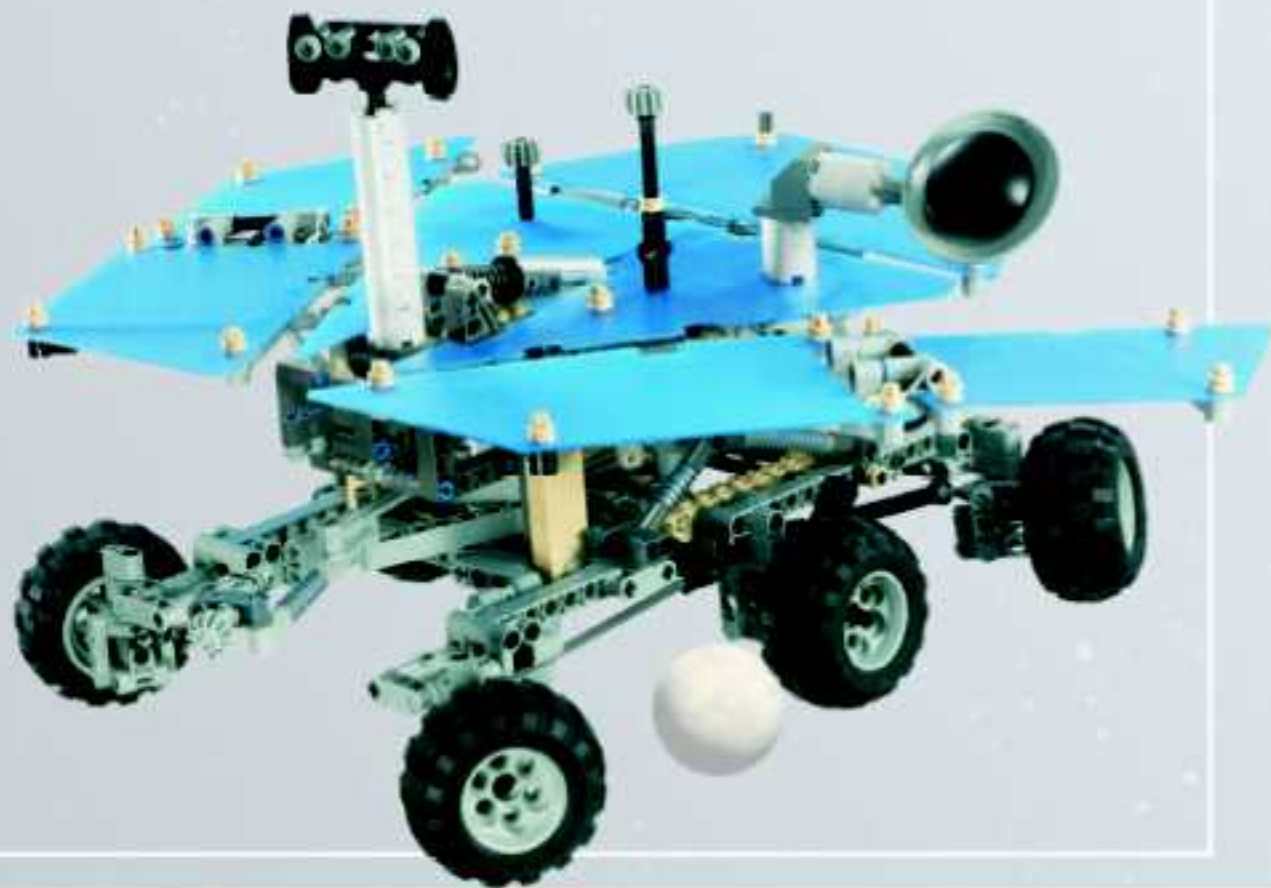

7468 SATURN V MOON MISSION



7470 SPACE SHUTTLE DISCOVERY





# Win! Gagne! Gewinne! 当たります



85220



## Win LEGO® products

We would really like to know what you think about your new LEGO® product.

If you could help us by answering a few questions at [www.acnielsen.aim.dk/lego](http://www.acnielsen.aim.dk/lego) then you are in with a chance of winning an exciting LEGO prize.

It will only take you about 3 minutes!



## Estimado usuario LEGO®

Al contestar algunas preguntas en inglés, francés, alemán o japonés, en el sitio [www.acnielsen.aim.dk/lego](http://www.acnielsen.aim.dk/lego), podrás participar en el sorteo de algunos valiosos premios LEGO®.



## Gagne des produits LEGO®

Nous aimerions beaucoup savoir ce que tu penses de ton nouveau produit LEGO®.

Si tu veux bien nous aider en répondant à quelques questions sur [www.acnielsen.aim.dk/lego](http://www.acnielsen.aim.dk/lego), tu recevras peut-être bientôt l'un des nombreux super-prix offerts par LEGO aux participants.

Et cela ne te prendra que 3 minutes environ !



## Kedves Ifjú LEGO® Vásárló

Ha ellátogatsz a [www.acnielsen.aim.dk/lego](http://www.acnielsen.aim.dk/lego) honlapra és ott angol, francia, német vagy japán nyelven megválaszolsz néhány kérdést, akkor részt veszel egy versenyben, amelyben értékes LEGO® díjakat nyerhetsz.



## 抽選でレゴ製品が当たります

私たちは、皆さんがレゴ製品についてどんな感想をお持ちか、是非知りたいと思っています。

[www.acnielsen.aim.dk/lego](http://www.acnielsen.aim.dk/lego)にアクセスいただき、質問にご回答いただきますと、抽選で楽しいレゴ製品が当たります。

アンケートのご回答には、ほんの3分ほどしかかかりません!



## Gewinne LEGO® Produkte

Wir sind sehr an deiner Meinung über dein neues LEGO® Produkt interessiert.

Wenn du uns den Gefallen tust und unter [www.acnielsen.aim.dk/lego](http://www.acnielsen.aim.dk/lego) Fragen beantwortest, kannst du einen tollen LEGO Preis gewinnen.

Das Ganze dauert nur etwa 3 Minuten!



## Caro Consumidor da LEGO®

Ao responder a algumas perguntas em Inglês, Francês, Alemão ou Japonês no endereço [www.acnielsen.aim.dk/lego](http://www.acnielsen.aim.dk/lego) irá participar num concurso para ganhar valiosos prémios da LEGO®.





LEGO and the LEGO logo are trademarks of the LEGO Group.  
©2003 The LEGO Group.



© 2003 Discovery Communications, Inc. All rights reserved. Discovery Channel, logo and Explore Your World! are trademarks of Discovery Communications, Inc.